

N90-22662

Program 10 Design of Cryogenic Tanks for Launch Vehicles

Charles Copper, W.D. Pilkey and J.K. Haviland

Objectives

The primary objective of this study is to find ways to reduce the life-cycle costs of cryogenic tanks for launch vehicles, such as the Advanced Launch Vehicle (ALS). A major saving can be achieved if the tanks are recoverable, however this introduces severe heating and aerodynamic loads, leading to thermo-structural design problems.

The secondary objective, which has been the focus of the present study, is to investigate the considerable reductions in manufacturing costs which are possible with sophisticated skin and stringer designs and with the use of new materials and fabrication techniques.

Design of Cryogenic Tanks for Launch Vehicles

W. D. Pilkey, J. K. Haviland, C. Copper
Department of Mechanical and Aerospace Engineering

Abstract

During the period since January 1990, work has been concentrated on the problem of the buckling of the structure of an ALS tank during the boost phase. The primary problem has been to analyze a proposed hat stringer made by superplastic forming, and to compare it with an integrally stiffened stringer design. A secondary objective has been to determine whether structural rings having the identical section to the stringers will provide adequate support against overall buckling. All of the analytical work has been carried out with the TESTBED program on the CONVEX computer at Langley, using the University of Virginia's PATRAN programs to create models.

Analyses of skin/stringer combinations have shown that the proposed stringer design is an adequate substitute for the integrally stiffened stringer. Using a highly refined mesh to represent the corrugations in the vertical webs of the hat stringers, effective values have been obtained for cross-sectional area, moment of inertia, centroid height, and torsional constant. Not only can these values be used for comparison with experimental values, but they can also be used for beams to replace the stringers and frames in analytical models of complete sections of tank. The same highly refined model was used to represent a section of skin reinforced by a stringer and a ring segment in the configuration of a cross. It was intended that this would provide a baseline buckling analysis representing a basic mode, however, the analysis proved to be beyond the scope of the CONVEX computer. One quarter of this model was analyzed, however, to provide information on buckling between the spot welds.

Models of large sections of the tank structure have been made, using beam elements to model the stringers and frames. In order to represent the stiffening effects of pressure, stresses and deflections under pressure should first be obtained, and then the buckling analysis should be made on the structure so deflected. So far, uncharacteristic deflections under pressure have been obtained from the TESTBED program using two types of structural elements. Similar results have been obtained using the ANSYS program on a mainframe computer, although two finite element programs on microcomputers have yielded realistic results. Pending a solution to this problem, a buckling analysis is to be made on the undeflected tank structure to determine whether the proposed rings are stiff enough to ensure conventional buckling of the stringers between the rings as opposed to overall buckling of rings and stringers.

The present work emphasizes the feasibility of the proposed stringer design, as opposed to providing a final design. To summarize, the stringers appear to be adequate, but the rings, as presently conceived, may be inadequate.

DESIGN OF CRYOGENIC TANKS FOR LAUNCH VEHICLES

NASA MONITORS: RUMMLER, DAVIS

UVA INVESTIGATORS: PILKEY, HAVILAND, COPPER

PRESENTATION BY CHARLES COPPER

PROBLEM: INVESTIGATE SPF VS INTEGRAL STRINGERS

ALS TANK

MODELLING OF SUBSTRUCTURES

FLAT PANELS

BEAM PROPERTIES OF SPF HAT STRINGER

INTERNAL BUCKLING OF SPF HAT STRINGER

PARTIAL MODELLING OF TANK

CONCLUSIONS

COMPLETE FUEL TANK

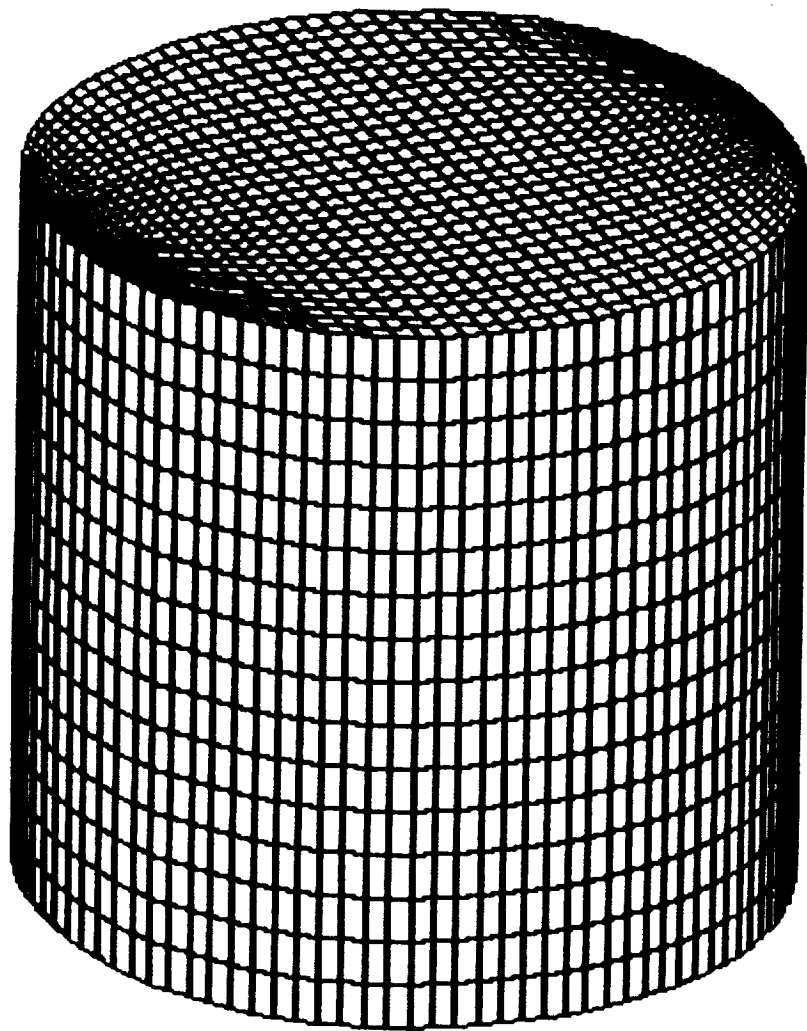

DESIGN INFORMATION

TANK DIAMETER		= 30 ft.
TANK HEIGHT		= 30 to 33 ft.
RING SPACING		= 20 to 30 ins.
STRINGER SPACING		= 10 to 15 ins.
WALL THICKNESS	TOP	= 0.25 ins.
	BOTTOM	= 0.60 ins.
DESIGN COMPRESSIVE LOAD		= 4,000 kips. (TOTAL)
INTERNAL PRESSURE HEAD		= 28 psi.
DESIGN LOAD IN WALLS		= 1,150 kips.
ULTIMATE LOAD IN WALLS		= 1,725 kips.

MODELLING OF SUBSTRUCTURES

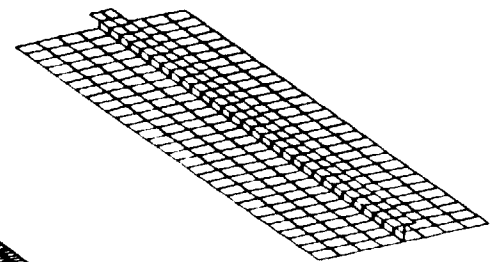
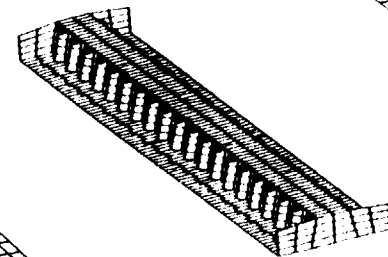
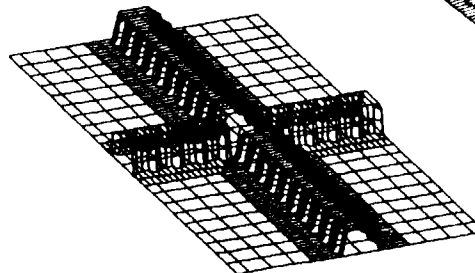
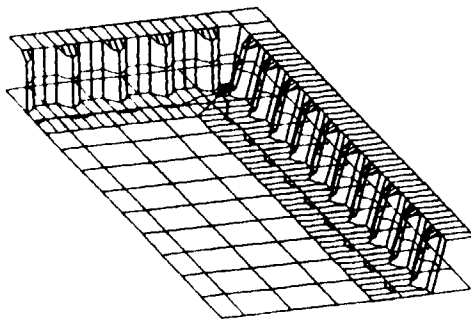
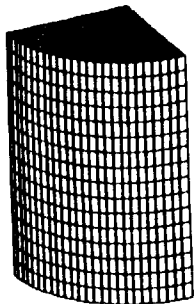
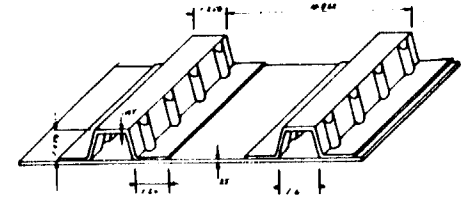
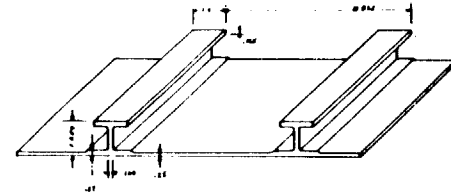
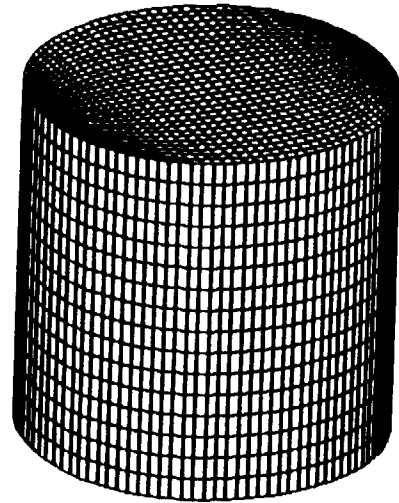
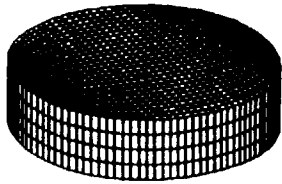

ORIGINAL PAGE IS
OF POOR QUALITY

MACHINED-OUT I-BEAMS

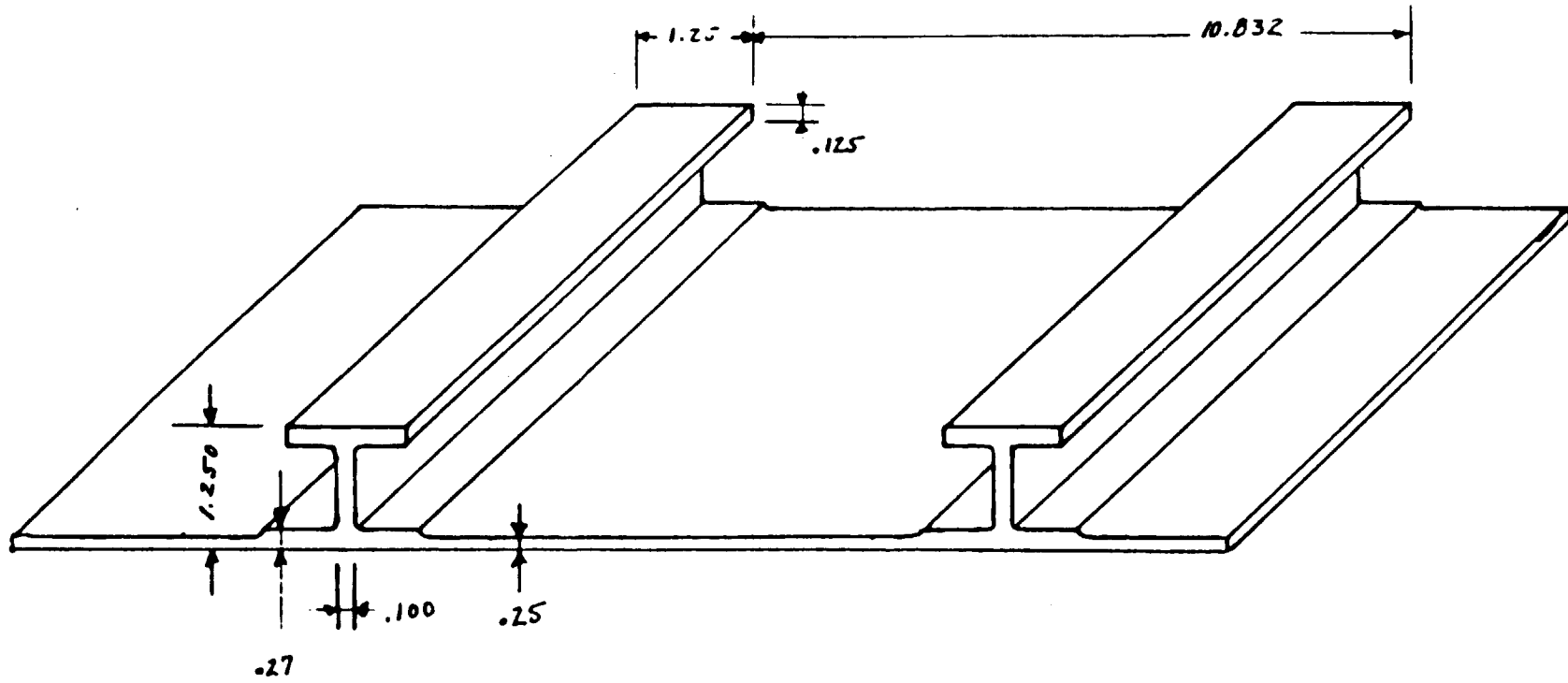

ORIGINAL PAGE IS
OF POOR
QUALITY

MACHINED-OUT I-BEAMS: TWO MODES

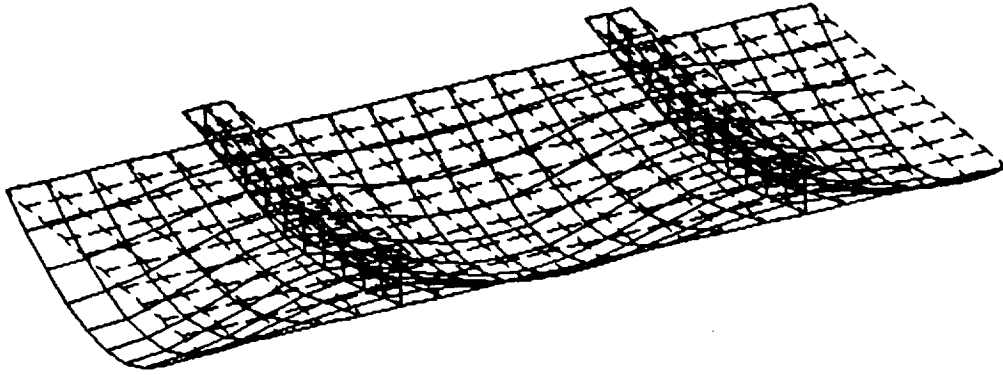

STRESS 73,600 psi; LOAD 20,800 kips

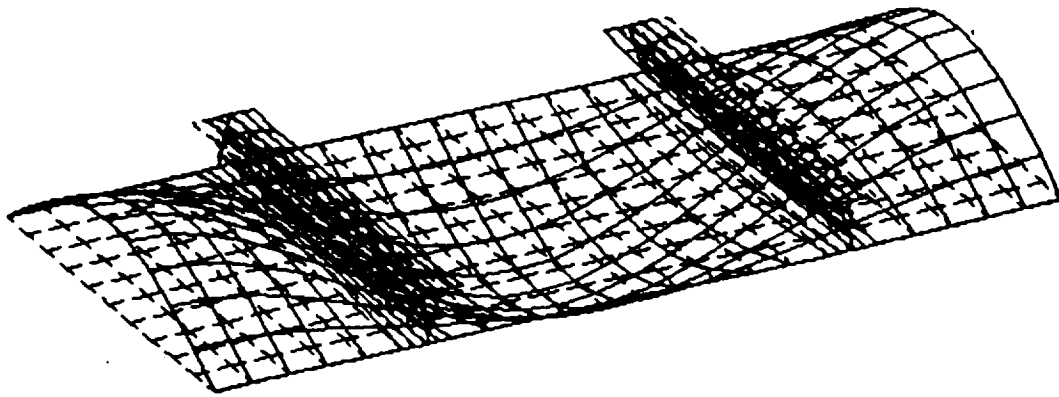

STRESS 19,000 psi; LOAD 5,400 kips

SPF HAT STRINGER

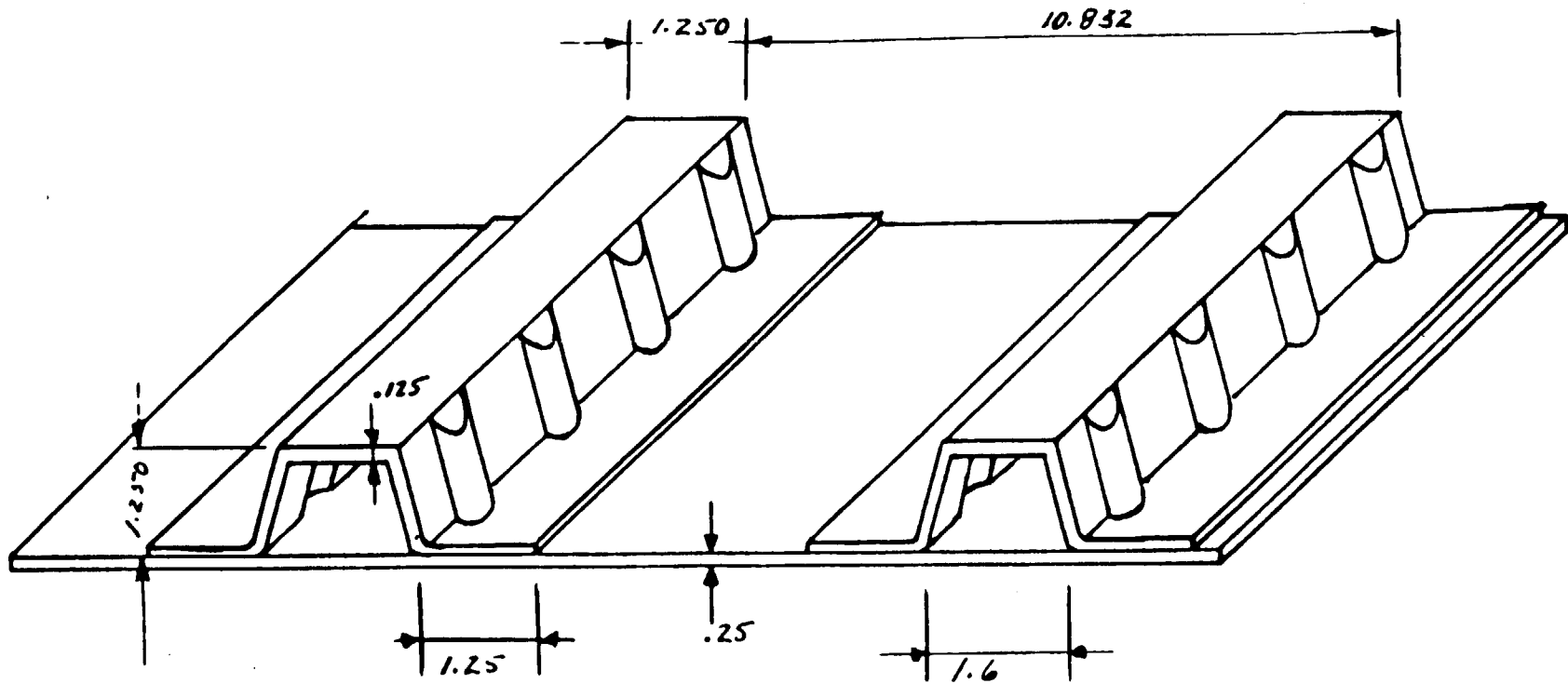

SPF HAT STRINGER: TWO MODES

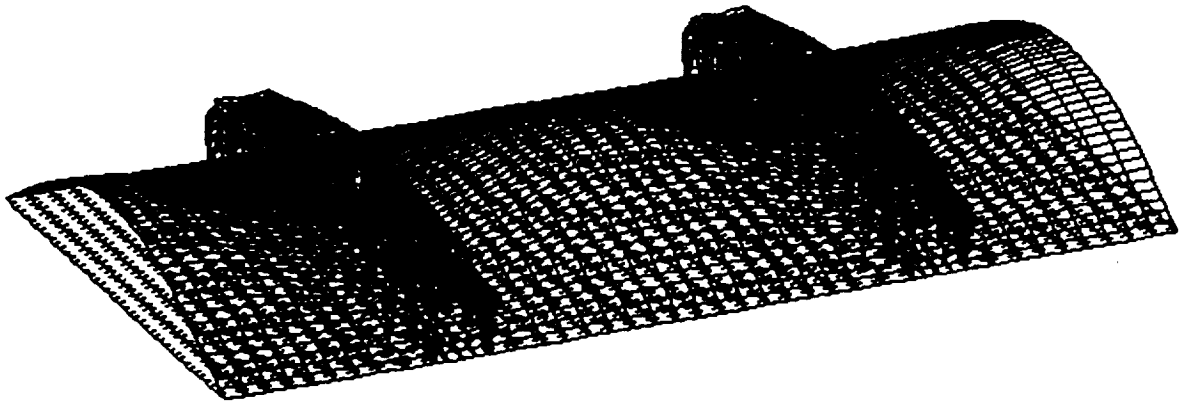

STRESS 26,400 psi; LOAD 7,500 kips

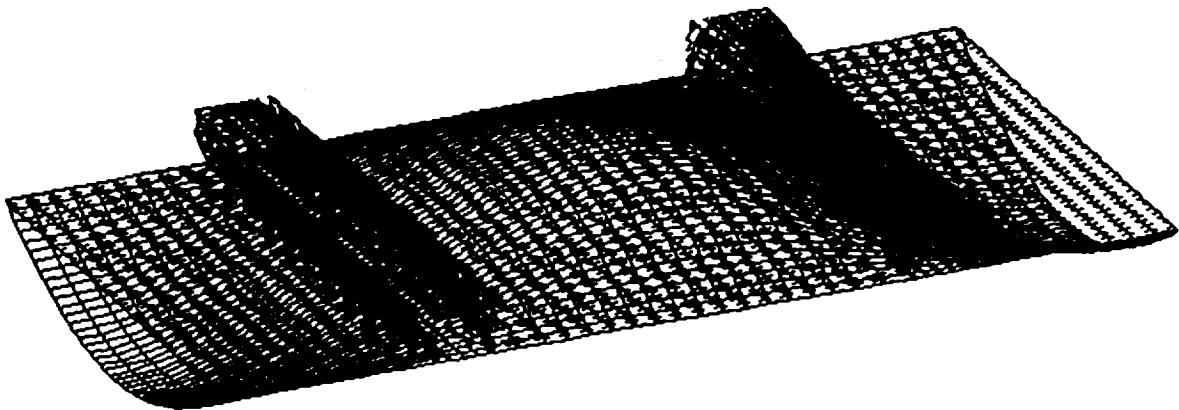

STRESS 24,500 psi; LOAD 6,900 kips

30" I-BEAM STRINGER & SKIN: TWO MODES

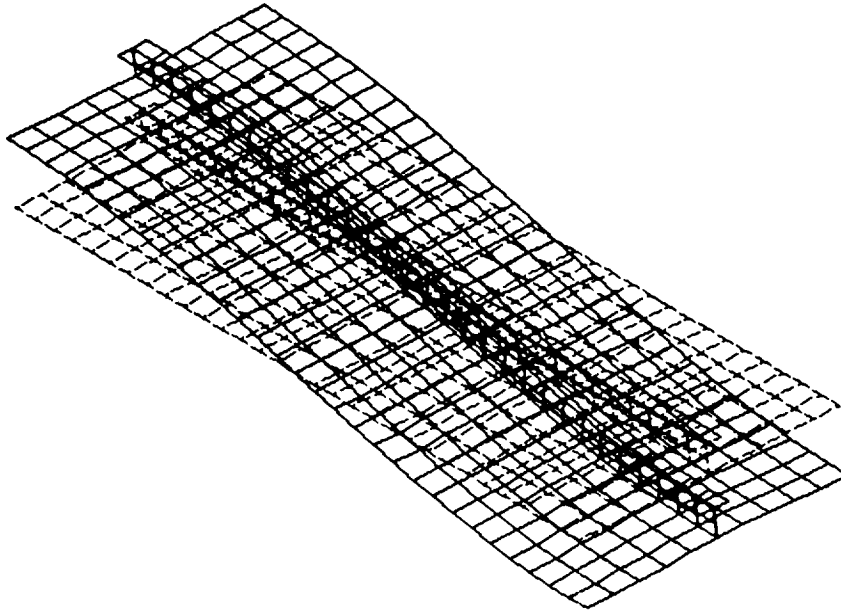

STRESS = 9,900 psi: LOAD = 2,800 kips

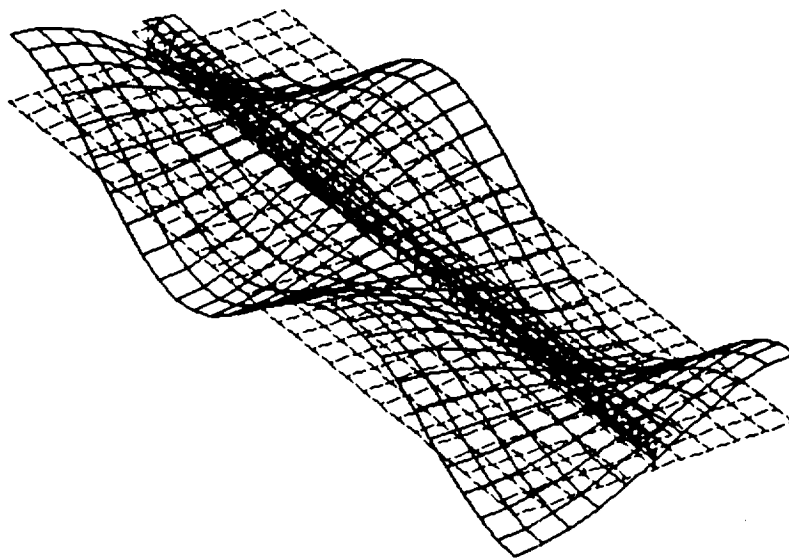

STRESS = 19,000 psi: LOAD = 5,400 kips

DETAIL MODEL OF SPF HAT STRINGER

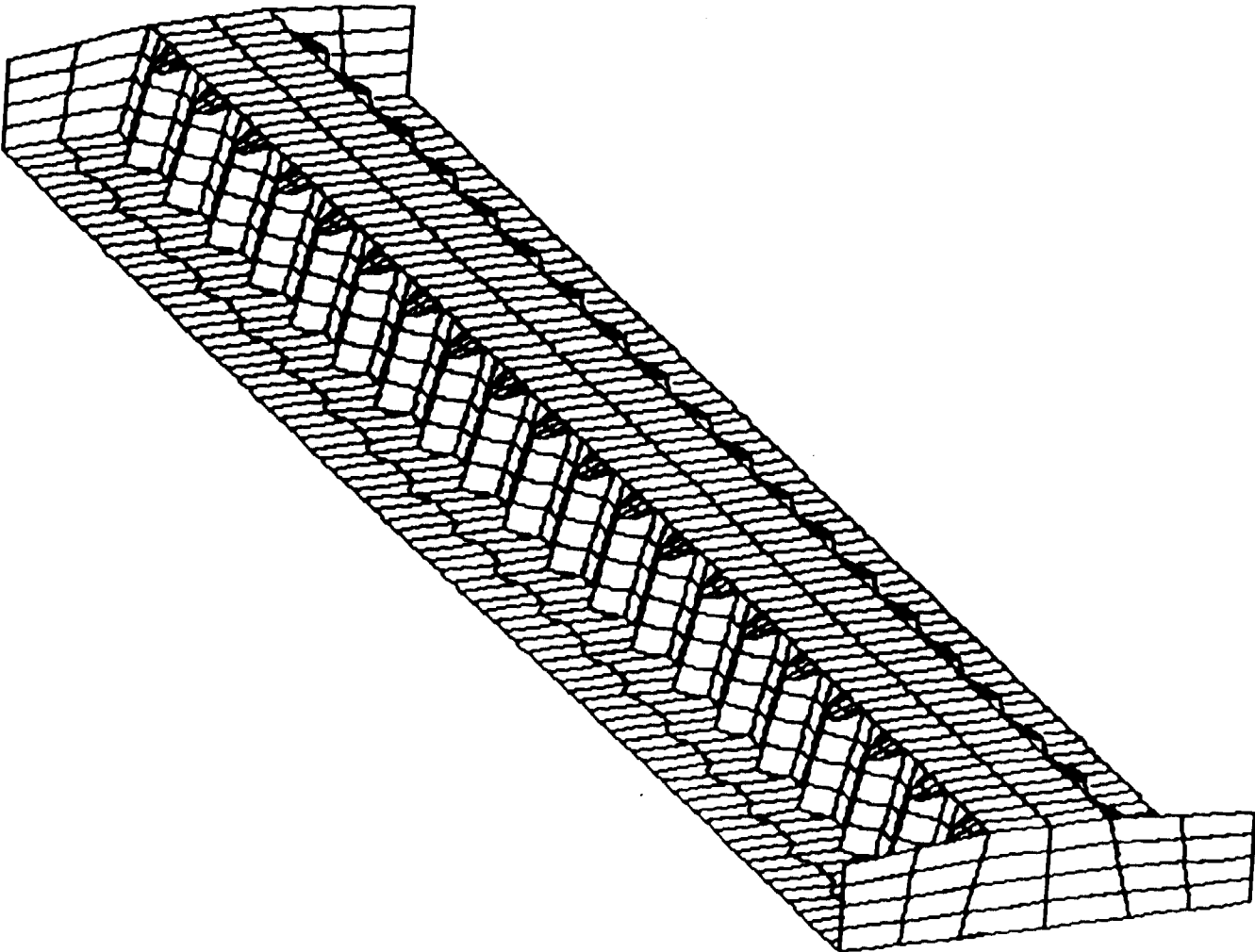

LOADED SPF HAT STRINGERS



COMPRESSION, $A_{\text{eff}} = 0.368 \text{ in}^2$

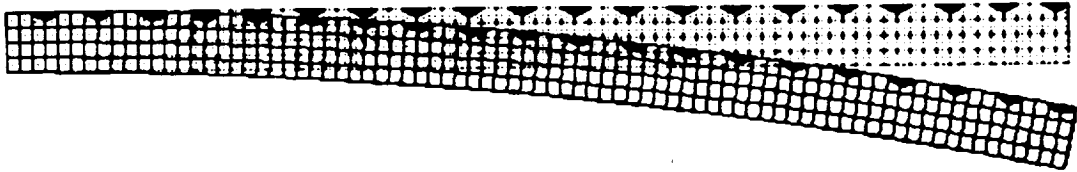

BENDING, $I_{\text{eff}} = 0.129 \text{ in}^4$

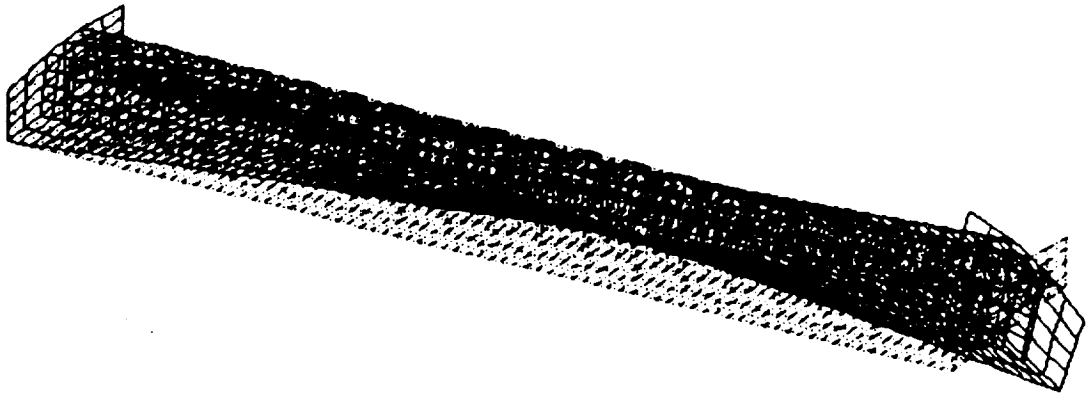

TORSION, $J_{\text{eff}} = 0.249 \text{ in}^4$

SPF STRINGER/FRAME PANEL

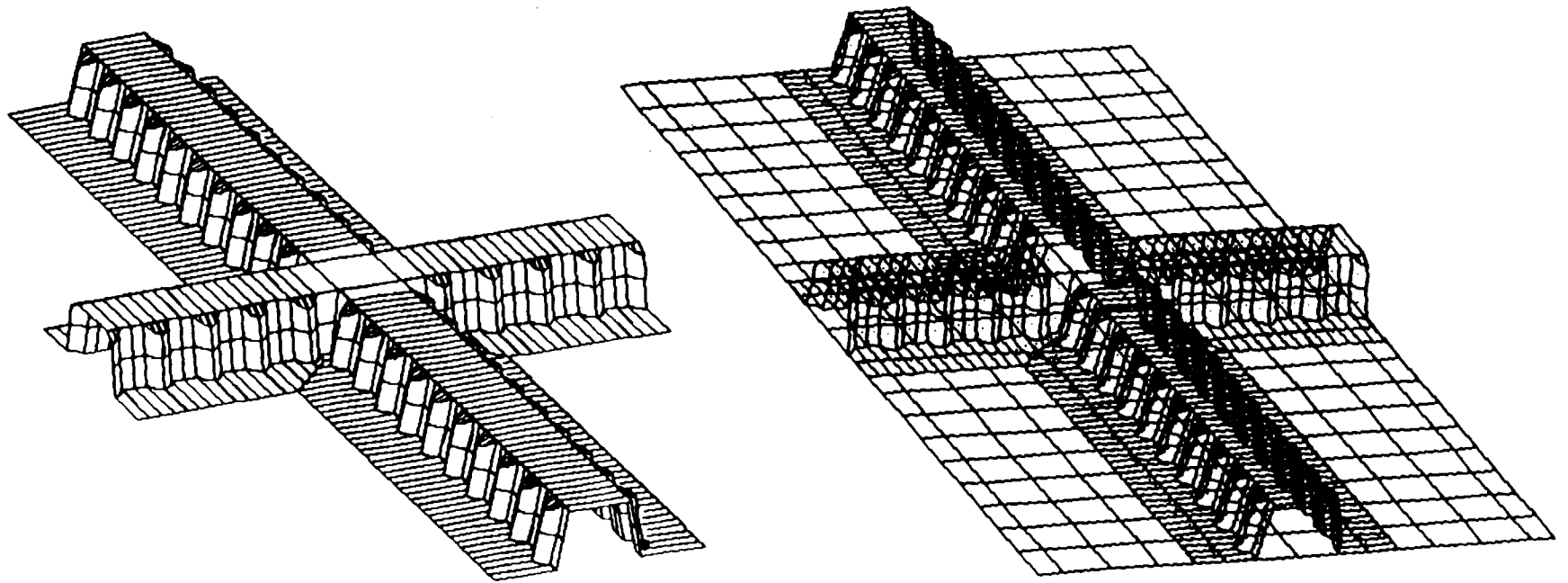

QUARTER SPF STRINGER/FRAME PANEL

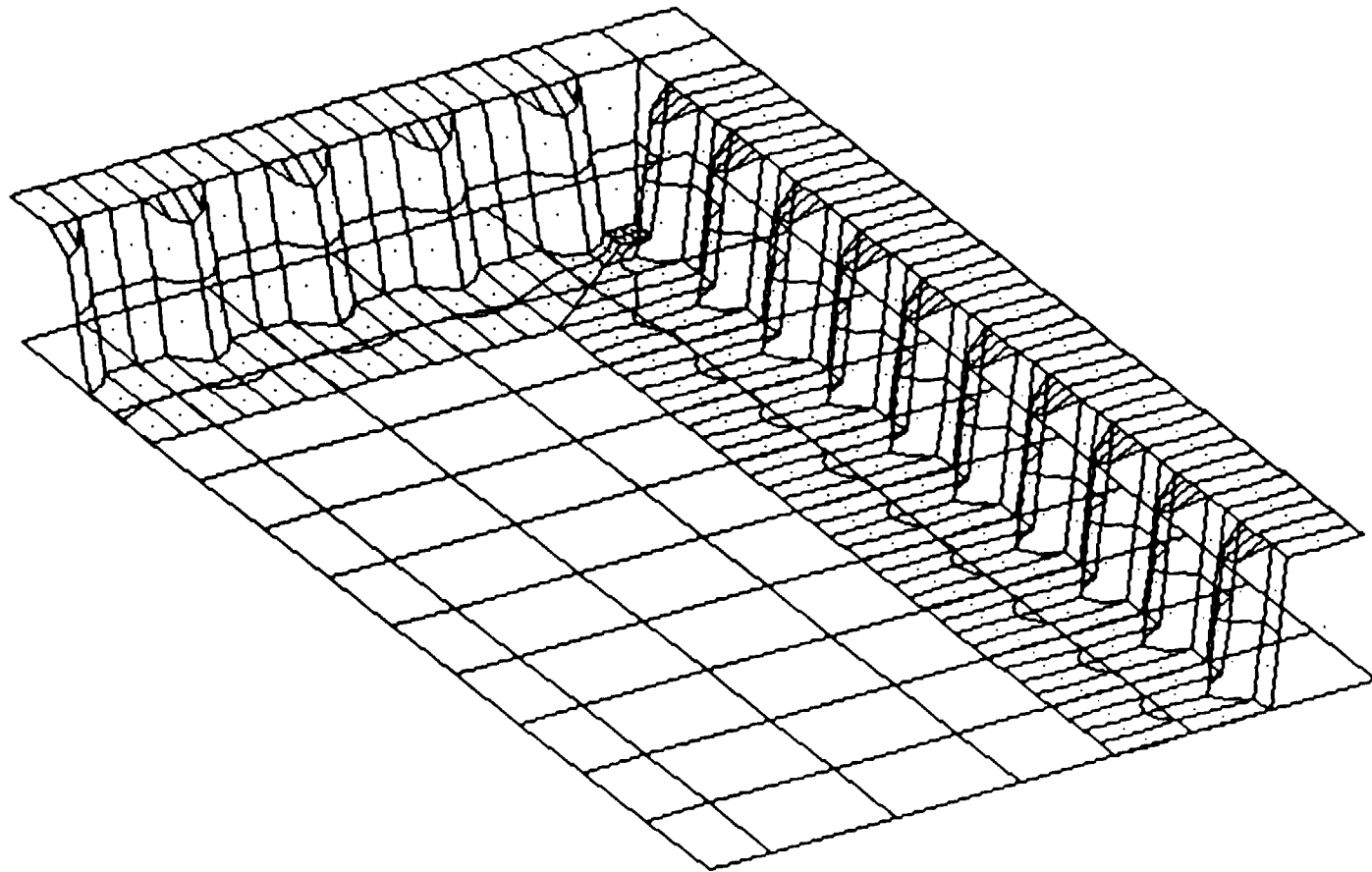

QUARTER SPF STRINGER/FRAME PANEL

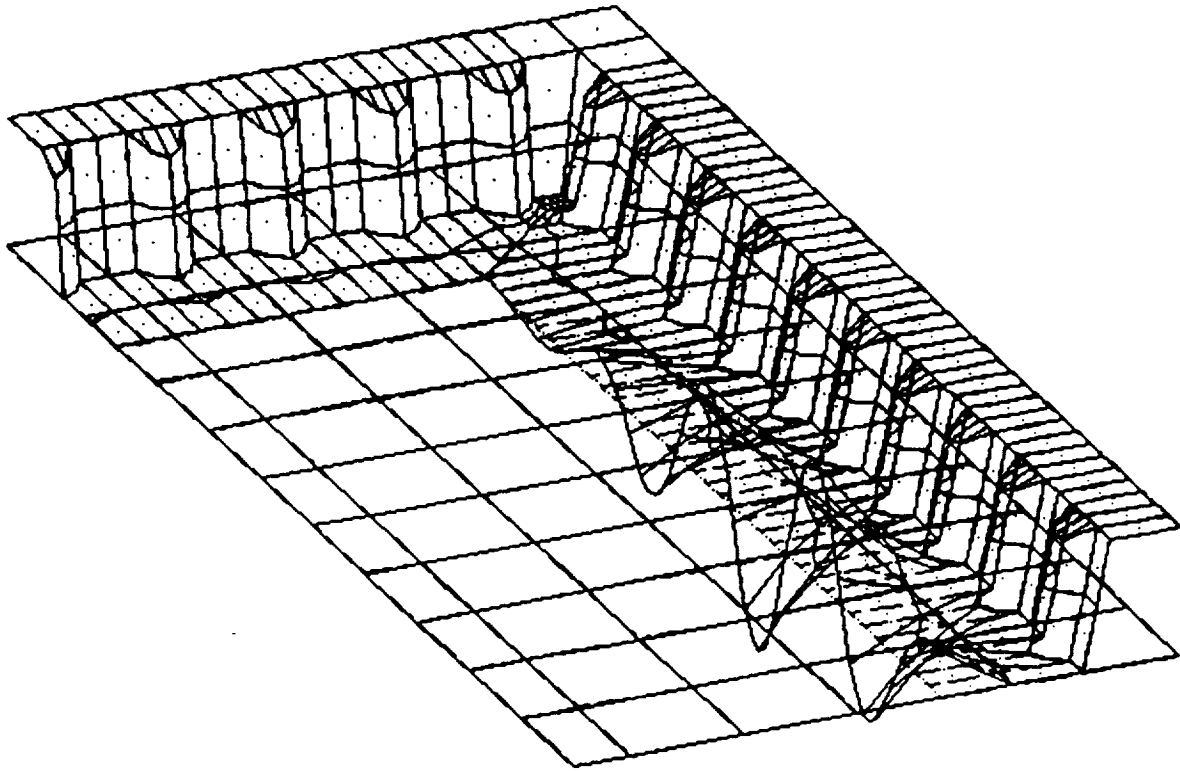

STRESS = 113,000 psi: LOAD = 32,000 kips

QUARTER SPF STRINGER/FRAME PANEL

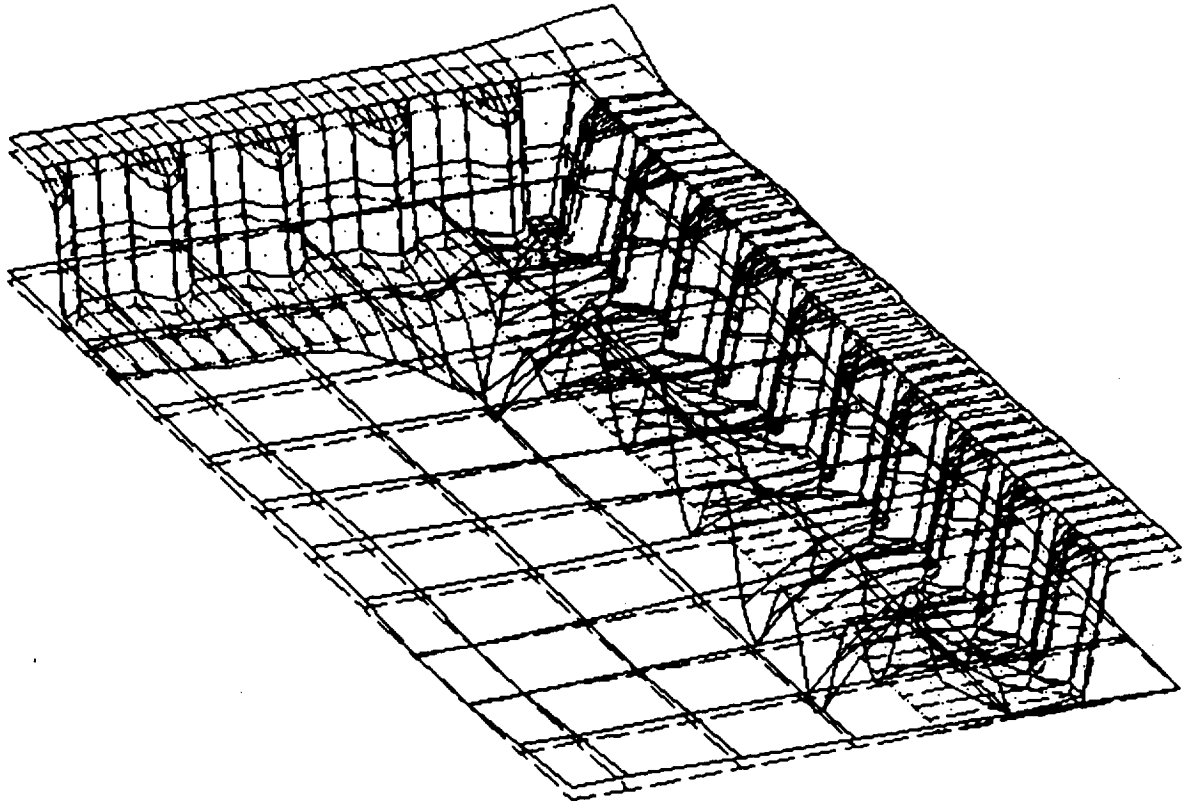

STRESS = 206,000 psi: LOAD = 58,000 kips

QUARTER SPF STRINGER/FRAME PANEL

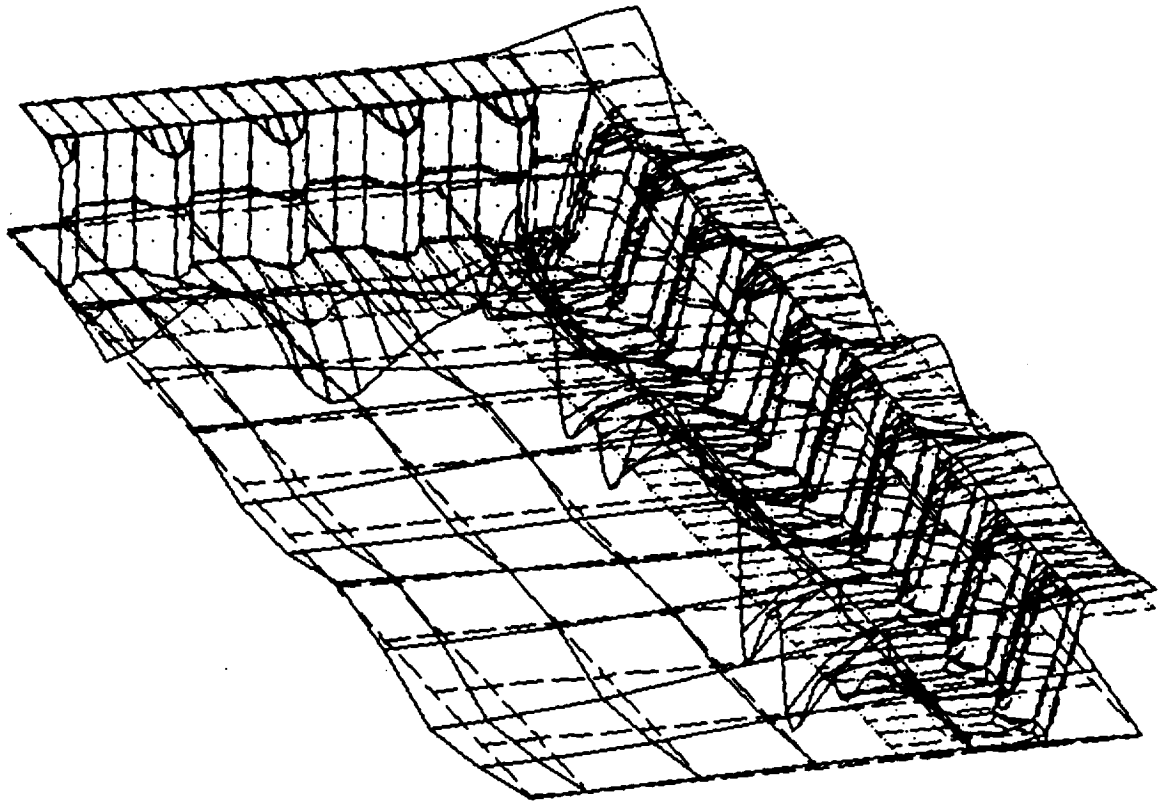

STRESS = 331,000 psi: LOAD = 94,000 kips

QUARTER WEDGE OF TANK

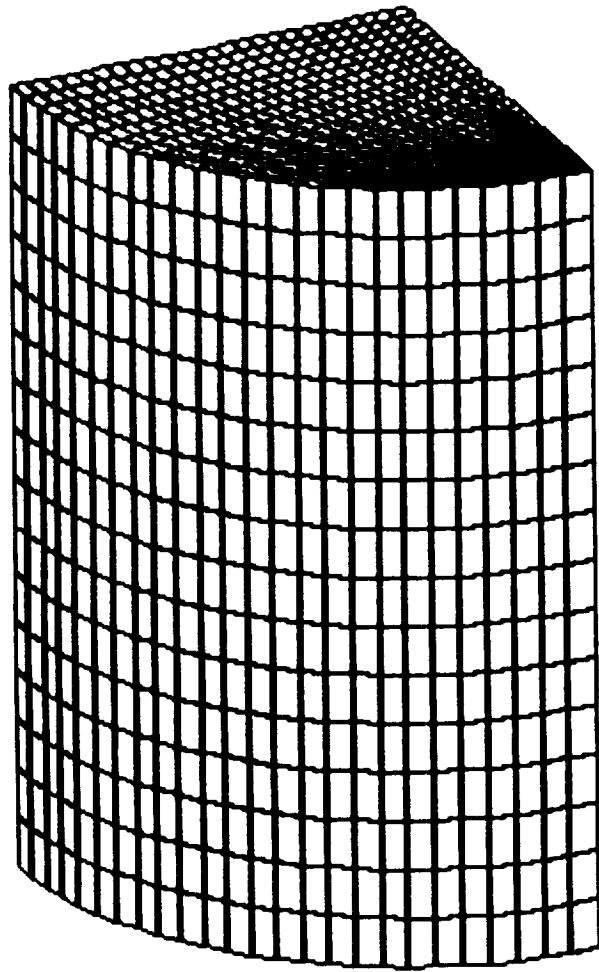

UPPER QUARTER OF TANK

