

N90-23055

## Substructural Controller Synthesis

Tzu-Jeng Su Roy R. Craig, Jr.

Department of Aerospace Engineering and Engineering Mechanics  
The University of Texas at Austin  
Austin, Texas 78712

A decentralized design procedure which combines substructural synthesis, model reduction, decentralized controller design, subcontroller synthesis, and controller reduction is proposed for the control design of flexible structures. The structure to be controlled is decomposed into several substructures, which are modelled by component mode synthesis methods. For each substructure, a subcontroller is designed by using the linear quadratic optimal control theory. Then, a controller synthesis scheme called Substructural Controller Synthesis (SCS) is used to assemble the subcontrollers into a system controller, which is to be used to control the whole structure.

### 1. Introduction

Component mode synthesis (CMS) methods [1,2] have proved to be indispensable for analyzing the dynamic response of large structural systems. Finite element models of order  $10^4$  are reduced, by the use of CMS methods, to order  $10^2$  to make possible the accurate numerical simulation of dynamic events. The most widely used CMS methods are those described in Refs. [3]-[6].

For the past decade there has been a growing interest in the topic of control of flexible structures, or control-structure interaction (CSI), but so far little has been done to employ CMS concepts in the design of controllers for flexible structures. Although many decentralized control methods have been developed for general linear systems, there have been few applications of decentralized control to flexible structures. In Ref. [7], Young applies the overlapping decomposition method, which was formulated by Ikeda and Šiljak for large scale systems [8,9], to develop a control design approach called Controlled Component Synthesis (CCS). The component finite element models employed by Young include boundary stiffness and inertia loading terms in the manner introduced in the CMS literature in Ref. [6]. The controller design is carried out at the component level. Then, the large controlled structure is synthesized from the controlled components. The idea behind the CCS approach is the same as that behind the CMS method. However, the way the structure is decomposed is not the same. Recently, in an attempt to simplify the decentralized control design for structures, Yousuff extended the concept of inclusion principle, which was developed along with the overlapping decomposition method by Ikeda et al. [9], to systems described in matrix second-order form [10]. The substructural model in Yousuff's work is an expanded component, i.e., the original boundary of the component is expanded into the adjacent component, which is similar to the substructure used in Young's CCS method. The expanded component is a result of overlapping decomposition.

---

The terms *component synthesis* and *substructure coupling* both refer to procedures whereby structures are considered to be composed of interconnected components, or substructures.

The need to "load" the boundary of one component with stiffness and inertia terms from the adjacent components is considered to be a drawback of the CMS method of Ref. [6] in comparison with the methods of Ref. [3]-[5]. Likewise, a decentralized control design procedure that is not based on overlapping components should have an advantage over the methods described in Refs. [7] and [10]. In this paper a decentralized control design process called *Substructural Controller Synthesis* (SCS), which was developed in Ref. [11], is described. Figure 1 shows the various steps involved in the SCS method described in this paper. First, a natural decomposition, called *substructuring decomposition*, of a structural dynamics system is defined. It is well known that for structural dynamics equations described in matrix second-order form, the system matrices of the whole structure can be assembled from the system matrices of substructures. For each substructure, a subcontroller is designed by an optimal control design method. Then, the system controller, which is to be used to control the whole structure, is synthesized from the subcontrollers by using the same assembling scheme as that employed for structure matrices. The last step is to reduce the order of the system controller to a reasonable size for implementation. This can be done by employing any existing efficient controller reduction method, for instance, the *Equivalent Impulse Response Energy Controller Reduction Algorithm* developed in Ref. [12]. The final control implementation in Figure 1 is a centralized control, which means the final controller for implementation is a system controller. However, the control design is decentralized, because each subcontroller is designed independently.

The substructure used in the Substructural Controller Synthesis method is a natural component, i.e., not an expanded component like that in Young's method. One advantage of using natural components is that SCS can be effectively incorporated with the Component Mode Synthesis method to design controllers for large scale structures. The substructures can be modelled by a CMS method and then assembled together to form an approximate model for the whole structure. The subcontrollers can be designed based on the CMS substructures and can then be assembled together to form a system controller for the whole structure. Another attractive feature of the SCS controller is that it can be updated economically if part of the structure changes. Since the system controller is synthesized from subcontrollers, if one substructure has a configuration or parameter change, the only subcontroller which needs to be redesigned is the one associated with that substructure. Therefore, the SCS controller is, in fact, an adaptable controller for structures with varying configuration and/or with varying mass and stiffness properties.

The organization of this paper is as follows. In Section 2, substructuring decomposition is defined for a general linear time-invariant system described by first-order equations. In Section 3, a substructuring decomposition for structural dynamics systems is developed. Then, based on the substructuring decomposition, a Substructural Controller Synthesis method is formulated in Section 4. Finally, in Section 5, a plane-truss example is used to illustrate the applicability of the proposed method.

## 2. Substructuring Decomposition

Consider a linear time-invariant system described by

$$\begin{aligned} S\dot{z} &= Az + Bu \\ y &= Cz \end{aligned} \tag{1}$$

where  $z \in R^n$  is the state vector,  $u \in R^l$  is the input vector, and  $y \in R^m$  is the output vector.  $S$ ,  $A$ ,  $B$ , and  $C$  are the system matrices with appropriate dimensions.

Next, consider another linear time-invariant system described by

$$\begin{aligned}\tilde{S}\dot{\tilde{z}} &= \tilde{A}\tilde{z} + \tilde{B}u \\ y &= \tilde{C}\tilde{z}\end{aligned}\quad (2)$$

with the system matrices in the following block diagonal form

$$\tilde{S} = \begin{bmatrix} S_1 & & & \\ & S_2 & & \\ & & \dots & \\ & & & S_\nu \end{bmatrix}, \quad \tilde{A} = \begin{bmatrix} A_1 & & & \\ & A_2 & & \\ & & \dots & \\ & & & A_\nu \end{bmatrix}, \quad \tilde{B} = \begin{bmatrix} B_1 & & & \\ & B_2 & & \\ & & \dots & \\ & & & B_\nu \end{bmatrix}, \quad \tilde{C} = \begin{bmatrix} C_1 & & & \\ & C_2 & & \\ & & \dots & \\ & & & C_\nu \end{bmatrix}$$

and

$$\tilde{z} = [z_1^T, z_2^T, \dots, z_\nu^T]^T, \quad u = [u_1^T, u_2^T, \dots, u_\nu^T]^T, \quad y = [y_1^T, y_2^T, \dots, y_\nu^T]^T$$

The dimensions of the variables are  $z_i \in R^{n_i}$ ,  $u_i \in R^{l_i}$ , and  $y_i \in R^{m_i}$ . It is assumed that system (1) and system (2) have the same set of inputs ( $\sum_{i=1}^{\nu} l_i = l$ ) and the same set of outputs ( $\sum_{i=1}^{\nu} m_i = m$ ). Therefore, for this case it is appropriate to use  $u$  and  $y$  in Eq. (2) as well as in Eq. (1). Because of the block diagonal form of the system matrices, system (2) is, in fact, a collection of  $\nu$  decoupled subsystems

$$\begin{aligned}S_i \dot{z}_i &= A_i z_i + B_i u_i \\ y_i &= C_i z_i\end{aligned}\quad i = 1, 2, \dots, \nu \quad (3)$$

Now let us define a substructuring decomposition. System (2) is said to be a *substructuring decomposition* of system (1) if there exists a *coupling matrix*  $\tilde{T}$  such that the following relationships hold

$$S = \tilde{T}^T \tilde{S} \tilde{T} \quad A = \tilde{T}^T \tilde{A} \tilde{T} \quad B = \tilde{T}^T \tilde{B} \quad C = \tilde{C} \tilde{T} \quad (4)$$

and if the states of the two systems can be related by

$$\tilde{z} = \tilde{T}z \quad (5)$$

The above relationships merely state that the system matrices of system (1) are assemblages of the system matrices of the subsystems in Eq. (3). Therefore, system (1) will be referred to as the *assembled system* and system (2) will be referred to as the *unassembled system*.

### 3. Substructuring Decomposition of Structural Dynamics Systems

In this section, the substructuring decomposition of a structural dynamics system is formulated. Without loss of generality, we will consider a structure composed of two substructures that have a common interface, as shown in Figure 2. It is assumed that the control inputs and the measurement outputs are localized. In the present context, "localized control inputs" means that the actuators are distributed such that  $u_\alpha$  is applied to the  $\alpha$ -substructure only and  $u_\beta$  is applied to the  $\beta$ -substructure only. "Localized measurements" means that  $y_\alpha$  measures only the response of the  $\alpha$ -substructure and  $y_\beta$  measures only the response of the  $\beta$ -substructure.

Let the equations of motion of the two substructures be represented by

$$\begin{aligned}M_i \ddot{x}_i + D_i \dot{x}_i + K_i x_i &= P_i u_i \\ y_i &= V_i x_i + W_i \dot{x}_i\end{aligned}\quad i = \alpha, \beta \quad (6)$$

It is noted here that the above dynamics equations for the substructures do not have to be exact (full-order) models. They can be approximate (reduced-order) models obtained by any model reduction method, say a Component Mode Synthesis method [2]. The dynamics of the the assembled structure (the structure as a whole) is described by

$$\begin{aligned} M\ddot{x} + D\dot{x} + Kx &= Pu \\ y &= Vx + W\dot{x} \end{aligned} \quad (7)$$

Since the two substructures have a common interface and are parts of the assembled structure, the displacement vectors of the substructures and the displacement vector of the assembled structure are related. There exists a coupling matrix  $T$  which relates  $x_\alpha$ ,  $x_\beta$ , to  $x$  as follows:

$$\begin{Bmatrix} x_\alpha \\ x_\beta \end{Bmatrix} = Tx = \begin{bmatrix} T_\alpha \\ T_\beta \end{bmatrix} x \quad (8)$$

Given the coupling matrix  $T$ , it can be shown that the system matrices of the assembled structure and the system matrices of the substructures satisfy the following relations:

$$\begin{aligned} M &= T^T \begin{bmatrix} M_\alpha & 0 \\ 0 & M_\beta \end{bmatrix} T, & D &= T^T \begin{bmatrix} D_\alpha & 0 \\ 0 & D_\beta \end{bmatrix} T, & K &= T^T \begin{bmatrix} K_\alpha & 0 \\ 0 & K_\beta \end{bmatrix} T \\ P &= T^T \begin{bmatrix} P_\alpha & 0 \\ 0 & P_\beta \end{bmatrix}, & V &= \begin{bmatrix} V_\alpha & 0 \\ 0 & V_\beta \end{bmatrix} T, & W &= \begin{bmatrix} W_\alpha & 0 \\ 0 & W_\beta \end{bmatrix} T \end{aligned} \quad (9)$$

The above relationships can be proved by using the method of Lagrange's equation of motion [1]. Therefore, it is an inherent property of structural dynamics systems that the system matrices of the assembled structure can be obtained by assembling the system matrices of the substructures. This property is, in fact, the essence of all "matrix assemblage" methods, e.g., the Finite Element Method and Component Mode Synthesis. The above formulation is based on the matrix second-order equation of motion. For control design purposes, a first-order formulation which leads to a substructuring decomposition of the structural dynamics system is required.

Let us rewrite the equation of motion (6) in the following first-order form

$$\begin{aligned} \begin{bmatrix} D_i & M_i \\ M_i & 0 \end{bmatrix} \begin{Bmatrix} \dot{x}_i \\ \ddot{x}_i \end{Bmatrix} &= \begin{bmatrix} -K_i & 0 \\ 0 & M_i \end{bmatrix} \begin{Bmatrix} x_i \\ \dot{x}_i \end{Bmatrix} + \begin{bmatrix} P_i \\ 0 \end{bmatrix} u_i \\ (S_i) \quad (z_i) & \quad (A_i) \quad (z_i) \quad (B_i) \end{aligned} \quad i = \alpha, \beta \quad (10)$$

$$y_i = \begin{bmatrix} V_i & W_i \end{bmatrix} \begin{Bmatrix} x_i \\ \dot{x}_i \end{Bmatrix} \quad (C_i) \quad (z_i)$$

where the symbol under each matrix denotes that this equation corresponds to Eq. (3). Similarly, Eq. (7) can be rewritten as

$$\begin{aligned} \begin{bmatrix} D & M \\ M & 0 \end{bmatrix} \begin{Bmatrix} \dot{x} \\ \ddot{x} \end{Bmatrix} &= \begin{bmatrix} -K & 0 \\ 0 & M \end{bmatrix} \begin{Bmatrix} x \\ \dot{x} \end{Bmatrix} + \begin{bmatrix} P \\ 0 \end{bmatrix} u \\ (S) \quad (z) & \quad (A) \quad (z) \quad (B) \end{aligned} \quad (11)$$

$$y = \begin{bmatrix} V & W \end{bmatrix} \begin{Bmatrix} x \\ \dot{x} \end{Bmatrix} \quad (C) \quad (z)$$

where the symbol under each matrix denotes that this equation corresponds to Eq. (1).

Combination of the two substructure equations in Eq. (10) gives the first-order equation of motion of the unassembled system in the form of Eq. (2).

$$\begin{aligned} \begin{bmatrix} S_\alpha & 0 \\ 0 & S_\beta \end{bmatrix} \begin{Bmatrix} \dot{z}_\alpha \\ \dot{z}_\beta \end{Bmatrix} &= \begin{bmatrix} A_\alpha & 0 \\ 0 & A_\beta \end{bmatrix} \begin{Bmatrix} z_\alpha \\ z_\beta \end{Bmatrix} + \begin{bmatrix} B_\alpha & 0 \\ 0 & B_\beta \end{bmatrix} \begin{Bmatrix} u_\alpha \\ u_\beta \end{Bmatrix} \\ \begin{matrix} (\tilde{S}) & (\tilde{z}) & (\tilde{A}) & (\tilde{z}) & \tilde{B} \end{matrix} & \end{matrix} \quad (12)$$

$$y \equiv \begin{Bmatrix} y_\alpha \\ y_\beta \end{Bmatrix} = \begin{bmatrix} C_\alpha & 0 \\ 0 & C_\beta \end{bmatrix} \begin{Bmatrix} z_\alpha \\ z_\beta \end{Bmatrix}$$

$$\begin{matrix} (\tilde{C}) \end{matrix}$$

It can be shown that the unassembled system (12) is a substructuring decomposition of the assembled system (11). That is,  $(S, A, B, C)$  in Eq. (11) and  $(\tilde{S}, \tilde{A}, \tilde{B}, \tilde{C})$  in Eq. (12) satisfy the relations in Eq. (4). The state vector of the assembled structure and the state vectors of the substructures are related by a coupling matrix  $\tilde{T}$  as

$$\begin{Bmatrix} x_\alpha \\ \dot{x}_\alpha \\ x_\beta \\ \dot{x}_\beta \end{Bmatrix} = \begin{bmatrix} T_\alpha & 0 \\ 0 & T_\alpha \\ T_\beta & 0 \\ 0 & T_\beta \end{bmatrix} \begin{Bmatrix} x \\ \dot{x} \end{Bmatrix}$$

$$\begin{matrix} (\tilde{z}) & (\tilde{T}) & (z) \end{matrix} \quad (13)$$

Physically, the coupling matrix  $\tilde{T}$  that relates the state vectors of the substructures and the state vector of the assembled structure simply describes the compatibility conditions which must be imposed on the interface degrees of freedom. Let  $x_i$  represent the physical displacement coordinates of substructures  $i$ , and let the physical coordinates of the substructures be partitioned into two sets: Interior coordinates (I-set) and Boundary coordinates (B-set), as shown in Figure 2.

The displacement compatibility condition requires that  $x_\alpha^B = x_\beta^B$ . If the displacement vector of the assembled structure is represented by

$$x = \begin{Bmatrix} x_\alpha^I \\ x^B \\ x_\beta^I \end{Bmatrix}$$

where  $x^B$  is the vector of interface degrees of freedom, then the three displacement vectors  $x_\alpha$ ,  $x_\beta$ , and  $x$  are related by

$$\begin{Bmatrix} x_\alpha \\ x_\beta \end{Bmatrix} \equiv \begin{Bmatrix} x_\alpha^I \\ x_\alpha^B \\ x_\beta^I \\ x_\beta^B \end{Bmatrix} = \begin{bmatrix} I & 0 & 0 \\ 0 & I & 0 \\ 0 & 0 & I \\ 0 & I & 0 \end{bmatrix} \begin{Bmatrix} x_\alpha^I \\ x^B \\ x_\beta^I \end{Bmatrix} \equiv \begin{bmatrix} T_\alpha \\ T_\beta \end{bmatrix} x \quad (14)$$

with

$$T_\alpha = \begin{bmatrix} I & 0 & 0 \\ 0 & I & 0 \end{bmatrix}, \quad T_\beta = \begin{bmatrix} 0 & 0 & I \\ 0 & I & 0 \end{bmatrix}$$

The velocity compatibility condition requires that  $\dot{x}_\alpha^B = \dot{x}_\beta^B$ , which leads to

$$\dot{x}_\alpha = T_\alpha \dot{x}, \quad \dot{x}_\beta = T_\beta \dot{x} \quad (15)$$

Combination of Eqs. (14) and (15) shows that the state vectors of the substructures and the state vector of the assembled structure are related by a coupling matrix  $\bar{T}$  as in Eq. (13).

#### 4. Substructural Controller Synthesis

The discussion in this section is based on the two-component structure in Section 3. The system is assumed to be subject to disturbance and observation noise. Therefore, the formulation is a stochastic one. At the end of this section, a control design procedure called the LQGSCS Algorithm is used to summarize the Substructural Controller Synthesis scheme. The method proposed can also be applied to a deterministic problem with only slight modification.

First, let the dynamics of the *assembled structure* (the structure as a whole) in Figure 2 be described by

$$\begin{aligned} S\dot{z} &= Az + Bu + N\varpi \\ y &= Cz + v \end{aligned} \quad (16)$$

where input disturbance  $\varpi$  and output disturbance  $v$  are assumed to be uncorrelated zero-mean white noise processes. For a linear stochastic system with incomplete measurement, optimal state feedback control design requires a state estimator, called a Kalman filter, to reconstruct the states for feedback. The state estimator of the plant described by Eq. (16) has the form

$$S\dot{q} = Aq + Bu + F^o(y - Cq) \quad (17)$$

where  $F^o$  is determined by solving a Riccati equation. If a feedback control scheme  $u = G^o q$  is incorporated with Eq. (17) to control the plant, the estimator becomes a controller in the form

$$\begin{aligned} S\dot{q} &= (A + BG^o - F^oC)q + F^o y \\ u &= G^o q \end{aligned} \quad (18)$$

where superscript  $o$  denotes optimal design. The feedback gain matrix  $G^o$  is determined by minimizing a performance index

$$J = \lim_{t \rightarrow \infty} \frac{1}{2} E[z^T Q z + u^T R u] \quad (19)$$

For structural control problems, the weighting matrix  $Q$  is usually chosen to be

$$Q = \begin{bmatrix} K & 0 \\ 0 & M \end{bmatrix} \quad (20)$$

such that the first term in the performance index represents the total energy of the structure. Since  $u$  is assumed to have the form indicated in Eq. (2), it is appropriate to choose the control weighting matrix  $R$  to have the form

$$R = \begin{bmatrix} R_\alpha & 0 \\ 0 & R_\beta \end{bmatrix} \quad (21)$$

The above centralized design scheme for a linear optimal compensator is well known. Now, a decentralized controller synthesis method, called the *Substructural Controller Synthesis* (SCS) method, will be formulated. The development of the Substructural Controller Synthesis method, which is stimulated by the substructuring decomposition and the Component Mode Synthesis method, is described in detail in Ref. [11]. The plant to be controlled is first decomposed into several substructures by the substructuring decomposition method. Then, for

each substructure a subcontroller is designed by using linear quadratic optimal control theory. The collection of all the subcontrollers is considered as the substructuring decomposition of a system controller that is to be employed to control the whole plant. Finally, the same coupling scheme that is employed for the plant is also used to synthesize the subcontrollers into a coupled system controller.

In order to show more clearly how the concept of substructuring decomposition is employed to assemble the subcontrollers, the collection of the two substructures is now considered as a single system, the *unassembled system*. The dynamic equation of the unassembled system can be written in a compact form

$$\begin{aligned}\tilde{S}\dot{\tilde{z}} &= \tilde{A}\tilde{z} + \tilde{B}u + \tilde{N}\varpi \\ y &= \tilde{C}\tilde{z} + v\end{aligned}\quad (22)$$

with

$$\begin{aligned}\tilde{S} &= \begin{bmatrix} S_\alpha & 0 \\ 0 & S_\beta \end{bmatrix}, & \tilde{A} &= \begin{bmatrix} A_\alpha & 0 \\ 0 & A_\beta \end{bmatrix}, & \tilde{B} &= \begin{bmatrix} B_\alpha & 0 \\ 0 & B_\beta \end{bmatrix}, \\ \tilde{N} &= \begin{bmatrix} N_\alpha & 0 \\ 0 & N_\beta \end{bmatrix}, & \tilde{C} &= \begin{bmatrix} C_\alpha & 0 \\ 0 & C_\beta \end{bmatrix}\end{aligned}$$

and

$$\tilde{z} = \begin{Bmatrix} z_\alpha \\ z_\beta \end{Bmatrix}, \quad u \equiv \begin{Bmatrix} u_\alpha \\ u_\beta \end{Bmatrix}, \quad y \equiv \begin{Bmatrix} y_\alpha \\ y_\beta \end{Bmatrix}, \quad \varpi \equiv \begin{Bmatrix} \varpi_\alpha \\ \varpi_\beta \end{Bmatrix}, \quad v \equiv \begin{Bmatrix} v_\alpha \\ v_\beta \end{Bmatrix}$$

The distribution of the input noise is assumed to be substructurally decomposable, i.e.,  $N = \tilde{T}^T \tilde{N}$ , so that system (22) is a substructuring decomposition of system (16). This assumption is not a serious restriction since, in general, distribution and intensity of the noise are uncertain quantities.

The performance index of the unassembled system is simply the summation of the performance indexes of the substructures

$$\tilde{J} = J_\alpha + J_\beta = \lim_{t \rightarrow \infty} \frac{1}{2} E[\tilde{z}^T \tilde{Q}\tilde{z} + u^T \tilde{R}u] \quad (23)$$

with

$$\tilde{Q} = \begin{bmatrix} Q_\alpha & 0 \\ 0 & Q_\beta \end{bmatrix}, \quad \tilde{R} = \begin{bmatrix} R_\alpha & 0 \\ 0 & R_\beta \end{bmatrix}$$

The optimal controller for the unassembled system, which is the collection of the two independently designed subcontrollers, can be written in compact form as

$$\begin{aligned}\tilde{S}\dot{\tilde{q}} &= (\tilde{A} + \tilde{B}\tilde{G}^\circ - \tilde{F}^\circ\tilde{C})\tilde{q} + \tilde{F}^\circ y \\ u &= \tilde{G}^\circ \tilde{q}\end{aligned}\quad (24)$$

with

$$\tilde{G}^\circ = \begin{bmatrix} G_\alpha^\circ & 0 \\ 0 & G_\beta^\circ \end{bmatrix}, \quad \tilde{F}^\circ = \begin{bmatrix} F_\alpha^\circ & 0 \\ 0 & F_\beta^\circ \end{bmatrix} \quad (25)$$

The last step is to assemble the subcontrollers by using the same coupling scheme as used for assembling the substructures. The assembled controller for the assembled system is represented by

$$\begin{aligned}S\dot{q} &= (A + BG^\circ - F^\circ C)q + F^\circ y \\ u &= G^\circ q\end{aligned}\quad (26)$$

with

$$F^\oplus = \tilde{T}^T \tilde{F}^\circ, \quad G^\oplus = \tilde{G}^\circ \tilde{T} \quad (27)$$

where superscript  $\oplus$  denotes that the controller is not optimal but is considered as suboptimal. The control design matrices  $F^\oplus$  and  $G^\oplus$  for the assembled structure are obtained by assembling the optimal control design matrices  $F_i^\circ$  and  $G_i^\circ$  for the substructures by using the coupling matrix  $\tilde{T}$ . If the assembled controller is employed to control the assembled structure, Eq. (16), the following closed-loop equation is obtained

$$\begin{bmatrix} S & 0 \\ 0 & S \end{bmatrix} \begin{Bmatrix} \dot{z} \\ \dot{q} \end{Bmatrix} = \begin{bmatrix} A & BG^\oplus \\ F^\oplus C & A + BG^\oplus - F^\oplus C \end{bmatrix} \begin{Bmatrix} z \\ q \end{Bmatrix} + \begin{bmatrix} N & 0 \\ 0 & F^\oplus \end{bmatrix} \begin{Bmatrix} w \\ v \end{Bmatrix} \quad (28)$$

Closed-loop stability of a Substructural Controller Synthesis design is, in general, not guaranteed. This is the same disadvantage that most indirect control design methods have. Indirect control design means that the controller is not designed based upon the exact full-order structure but is based on an approximate model or reduced-order model. From the form of Eq. (28), it is seen that the separation principle is applicable to the SCS control system. The closed-loop poles of the assembled system are the union of the regulator poles (eigenvalues of  $S^{-1}(A + BG^\oplus)$ ) and the observer poles (eigenvalues of  $S^{-1}(A - F^\oplus C)$ ). Therefore, stability of the assembled closed-loop system can be checked by examining the locations of these two sets of eigenvalues.

One advantage of using Substructural Controller Synthesis to design a controller is that an SCS controller is highly adaptable. For a structure with varying configuration or varying mass and stiffness properties, like some space structures, the Substructural Controller Synthesis method may be especially efficient. The SCS controller can be updated economically by simply carrying out redesign of subcontrollers associated with those substructures that have changed. On the other hand, for a controller based on a centralized design scheme, a slight change of the structure may require a full-scale redesign. This favorable decentralized feature of the Substructural Controller Synthesis method is similar to that of the Component Mode Synthesis method in the application to model modification.

## 5. Example

A plane truss example is used to demonstrate the applicability of the Substructural Controller Synthesis method. The example consists of two identical substructures with almost co-located sensor and actuator allocations. The truss structure, which is shown in Figure 3, consists of six bays and has twenty degrees-of-freedom. Two force actuators and two displacement sensors are allocated symmetrically at  $f$  and  $d$ , respectively. The actuators are contaminated by disturbances with intensity  $10^{-3}$ . The sensors are contaminated by noises with intensity  $10^{-12}$ . These levels of noise intensities are chosen arbitrarily just for the purpose of example study, and are not justified by the experience of any real case. (In Ref. [13], there is an example with input noise intensity  $10^{-4}$  and output noise intensity  $10^{-15}$ .) All disturbances are assumed to be uncorrelated zero-mean white noise processes. The mass and stiffness matrices for the structure are obtained by the finite element method. The damping matrix is chosen to be 1/1000 of the stiffness matrix. The eigenvalues of the open-loop system have damping ratios ranging from 0.05% to 1.5%. The structure is divided into two substructures as shown in Figure 3.

In order to illustrate in some sense the "adaptable" feature of the method, SCS control design has been carried out and compared with the full-order optimal controller for three



different cases. Conditions, assumptions, formulations, and results for the three cases studied are summarized in the following.

**Case 1: (Two-input and two-output)**

For this case, the two substructures are identical due to symmetry. Therefore, only one substructural level control design need be carried out. The other subcontroller can be obtained by using symmetry. The results are shown in Table 1 and Figure 4, in which  $R$  is the weighting of control cost in the performance index. It is seen that the SCS controller has a near-optimal performance. The performance value of the SCS controller is less than 4% higher than the performance value of the optimal controller. The substructures and subcontrollers for this case are symbolically represented by the following equations.

Left substructure

$$\begin{aligned} S_1 \dot{z}_1 &= A_1 z_1 + B_1 u_1 + B_1 \varpi_1 \\ y_1 &= C_1 z_1 + v_1 \end{aligned}$$

Left subcontroller

$$\begin{aligned} S_1 \dot{q}_1 &= (A_1 + B_1 G_1^o - F_1^o C_1) q_1 + F_1^o y_1 \\ u_1 &= G_1^o q_1 \end{aligned}$$

Right substructure

$$\begin{aligned} S_2 \dot{z}_2 &= A_2 z_2 + B_2 u_2 + B_2 \varpi_2 \\ y_2 &= C_2 z_2 + v_2 \end{aligned}$$

Right subcontroller

$$\begin{aligned} S_2 \dot{q}_2 &= (A_2 + B_2 G_2^o - F_2^o C_2) q_2 + F_2^o y_2 \\ u_2 &= G_2^o q_2 \end{aligned}$$

**Case 2: (Two-input and single-output)**

Assume that the right sensor has malfunctioned. In this case, the right substructure is not observable. The generalized subcontroller for the right substructure is defined to be a full-state feedback controller, although there is really no state estimator available. Comparisons of the SCS controller and the full-order optimal controller are summarized by Table 2 and Figure 5. It is seen that the performance of the SCS controller for this case is not as good as that for the previous case. The substructures and subcontrollers for this case are symbolically represented by the following equations.

Left substructure

$$\begin{aligned} S_1 \dot{z}_1 &= A_1 z_1 + B_1 u_1 + B_1 \varpi_1 \\ y_1 &= C_1 z_1 + v_1 \end{aligned}$$

Left subcontroller

$$\begin{aligned} S_1 \dot{q}_1 &= (A_1 + B_1 G_1^o - F_1^o C_1) q_1 + F_1^o y_1 \\ u_1 &= G_1^o q_1 \end{aligned}$$

Right substructure

$$S_2 \dot{z}_2 = A_2 z_2 + B_2 u_2 + B_2 \varpi_2$$

Right generalized subcontroller

$$\begin{aligned} S_2 \dot{q}_2 &= (A_2 + B_2 G_2^o) q_2 \\ u_2 &= G_2^o q_2 \end{aligned}$$

**Case 3: (Two-input and single-output; right substructure noise-free)**

We suspect that the poor performance of the SCS controller in Case 2 is due to the fact that there is not an observer to filter the noise on the right substructure. Therefore, as another case for study, we consider the same actuator/sensor configuration as that of Case 2, but assume that the right substructure is free of disturbance. The results are summarized by Table 3 and Figure 6. The SCS controller for this case has a near-optimal performance. The substructures

and subcontrollers for this case are symbolically represented by the following equation.

Left substructure

$$\begin{aligned} S_1 \dot{z}_1 &= A_1 z_1 + B_1 u_1 + B_1 w_1 \\ y_1 &= C_1 z_1 + v_1 \end{aligned}$$

Left subcontroller

$$\begin{aligned} S_1 \dot{q}_1 &= (A_1 + B_1 G_1^\circ - F_1^\circ C_1) q_1 + F_1^\circ y_1 \\ u_1 &= G_1^\circ q_1 \end{aligned}$$

Right substructure

$$S_2 \dot{z}_2 = A_2 z_2 + B_2 u_2$$

Right generalized subcontroller

$$\begin{aligned} S_2 \dot{q}_2 &= (A_2 + B_2 G_2^\circ) q_2 \\ u_2 &= G_2^\circ q_2 \end{aligned}$$

From the results of the above three cases, it is seen that, for this example, the performance of the SCS controller is, in general, near-optimal. The only situation where the SCS controller exhibited a poor performance is Case 2, in which the right substructure is subject to disturbance but has no output measurement as a feedback to filter the noise. Additional cases are presented in Ref. [11].

## 6. Conclusions

A decentralized linear quadratic control design method called Substructural Controller Synthesis is proposed for the control design of flexible structures. The SCS method presented in this paper is only a preliminary research result. It is not a fully-developed method, but rather a proposed controller design technique which requires further research. Although some numerical examples have shown promising results, theoretical aspects of the SCS method still need to be pursued in greater depth and other examples need to be considered. The example illustrated does not involve model reduction and controller reduction. However, the method is ready to be incorporated with component mode synthesis and controller reduction methods.

## References

1. Craig, R. R. Jr., *Structural Dynamics - An Introduction to Computer Methods*, John Wiley & Sons, Inc. NY, 1981.
2. Craig, R. R. Jr., "A Review of Time-Domain and Frequency-Domain Component Modes Synthesis Methods," *Combined Experimental/Analytical Modeling of Dynamic Structural Systems*, AMD-Vol. 67, ASME, NY, pp. 1-30, 1985. Also *International Journal of Analytical and Experimental Modal Analysis*, Vol. 67, pp. 1-30.
3. Hurty, W. C., "Dynamic Analysis of Structural Systems Using Component Modes," *AIAA J.*, Vol. 3, pp. 678-685, 1965.
4. Craig, R. R. Jr. and Bampton, M. C. C., "Coupling of Substructures for Dynamic Analysis," *AIAA J.*, Vol. 6, pp. 1313-1316, 1968.
5. MacNeal, R. H., "A Hybrid Method of Component Mode Synthesis," *Comp. & Struct.*, Vol. 1, pp. 581-601, 1971.
6. Benfield, W. A. and Hruda, R. F., "Vibration Analysis of Structures by Component Mode Substitution," *AIAA J.*, Vol. 9, pp. 1255-1261, 1971.
7. Young, K. D., "A Distributed Finite Element Modeling and Control Approach for Large Flexible Structures," to appear *J. Guidance, Control, and Dynamics*.
8. Ikeda, M. and Šiljak, D. D., "Overlapping Decompositions, Expansions, and Contractions of Dynamic Systems," *Large Scale Systems*, Vol. 1, pp. 29-38, 1980.

9. Ikeda, M., Šiljak, D. D., and White, D. E., "An Inclusion Principle for Dynamic Systems," *IEEE Trans. Automat. Control*, Vol. 29, No. 3, pp. 244-249, 1984.
10. Yousuff, A., "Application of Inclusion Principle to Mechanical Systems," *Proceedings of 1988 American Control Conference*, Atlanta, GA, June 15-17, pp. 1516-1520, 1988.
11. Su, T. J., "A Decentralized Linear Quadratic Control Design Method For Flexible Structures," Ph.D. dissertation, The University of Texas at Austin, Austin, Texas, August 1989.
12. Su, T. J. and Craig, R. R. Jr., "Controller Reduction By Preserving Impulse Response Energy," *AIAA Guidance, Navigation and Control Conference*, Boston, MA, pp. 55-64, August 14-17, 1989.
13. Yousuff, A. and Skelton, R. E., "Controller Reduction by Component Cost Analysis," *IEEE Trans. Automat. Control*, Vol. 29, No. 6, pp. 520-530, 1984.

Table 1: Performance values of Case 1

R=	0.01	0.05	0.1	0.5	1	5	10
Optimal	1.1737E-4	1.7796E-4	2.1445E-4	3.3929E-4	4.1689E-4	6.7621E-4	8.3436E-4
SCS method	1.2155E-4	1.8168E-4	2.1856E-4	3.4522E-4	4.2385E-4	6.8522E-4	8.4451E-4
Difference	3.6%	2.1%	1.9%	1.7%	1.7%	1.3%	1.2%

Table 2: Performance values of Case 2

R=	0.01	0.05	0.1	0.5	1	5	10
Optimal	1.3742E-4	1.9240E-4	2.2709E-4	3.4887E-4	4.2544E-4	6.8283E-4	8.4029E-4
SCS method	5.3709E-4	6.6359E-4	7.0535E-4	7.9789E-4	8.4867E-4	1.0293E-3	1.1520E-3
Difference	291%	245%	210%	129%	99%	51%	37%

Table 3: Performance values of Case 3

R=	0.01	0.05	0.1	0.5	1	5	10
Optimal	5.9433E-5	8.9437E-5	1.0763E-4	1.6989E-4	2.0863E-4	3.3822E-4	4.1726E-4
SCS method	6.1968E-5	9.1607E-5	1.0989E-4	1.7296E-4	2.1219E-4	3.4275E-4	1.1520E-3
Difference	4.3%	2.4%	2.1%	1.8%	1.7%	1.3%	1.2%

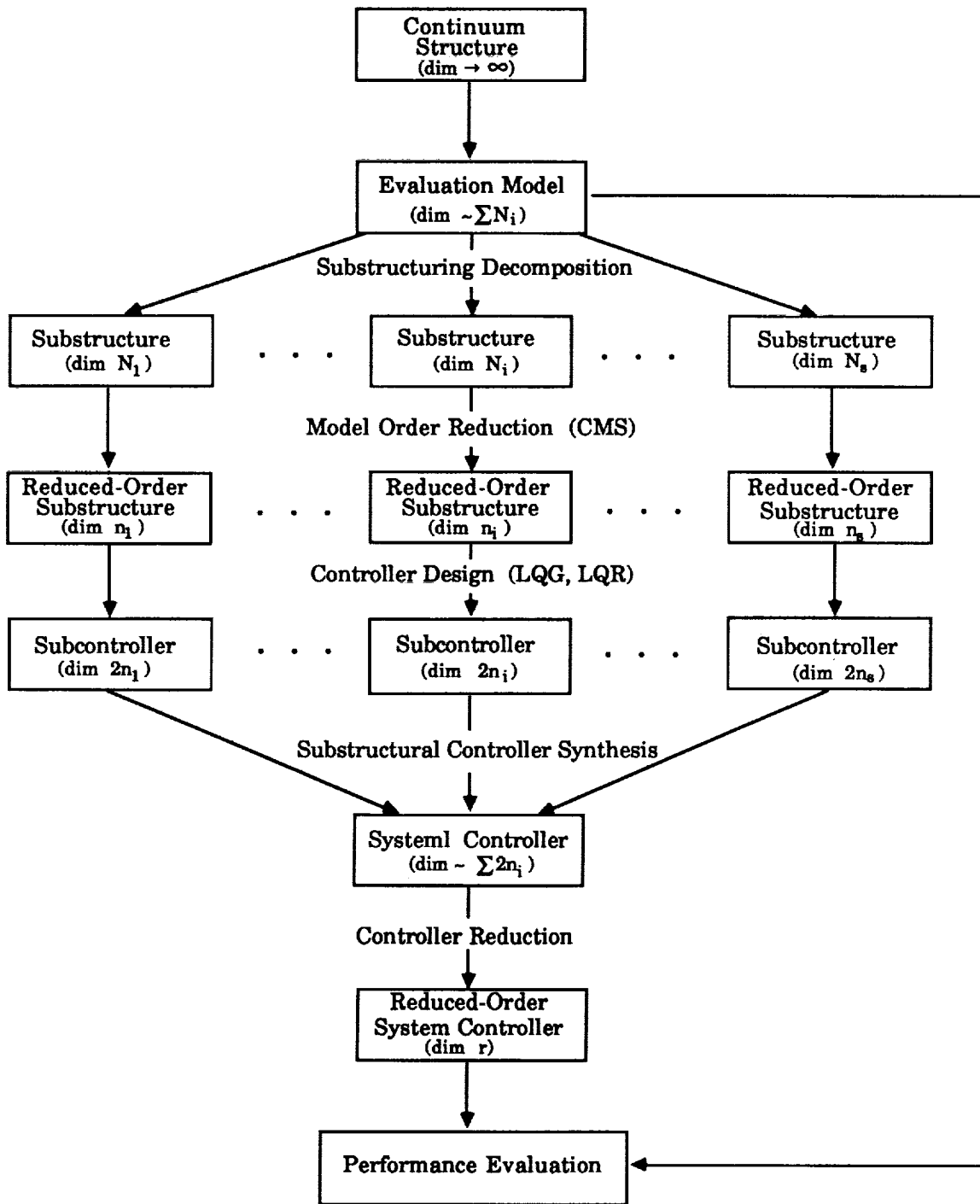

Figure 1: Steps in Substructural Controller Synthesis method

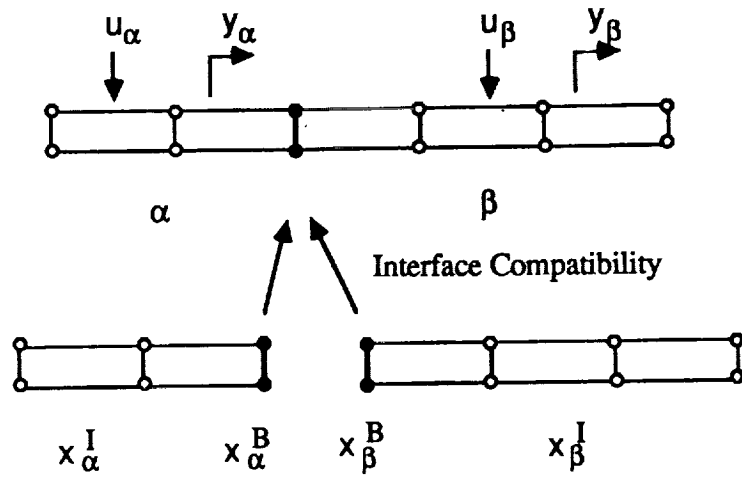

Figure 2: Two-component structure

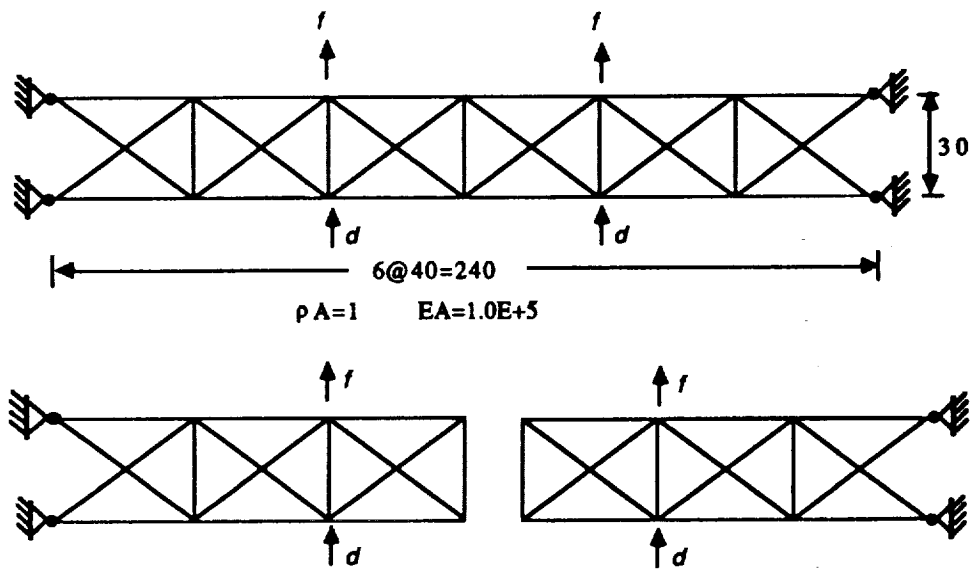

Figure 3: Details of the plane truss for the SCS design example

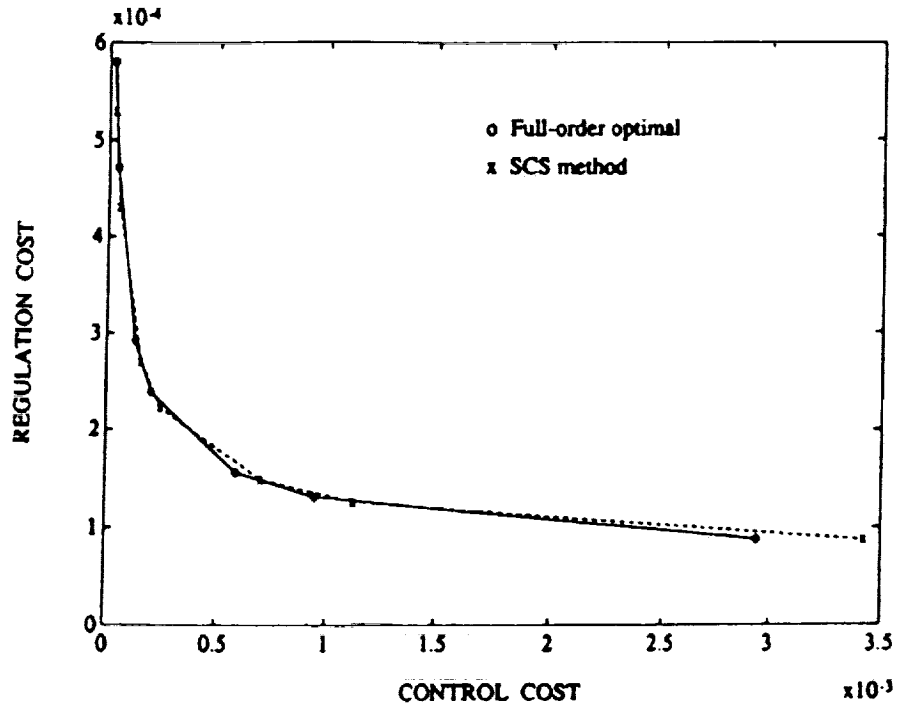

Figure 4: Performance plot of Case 1

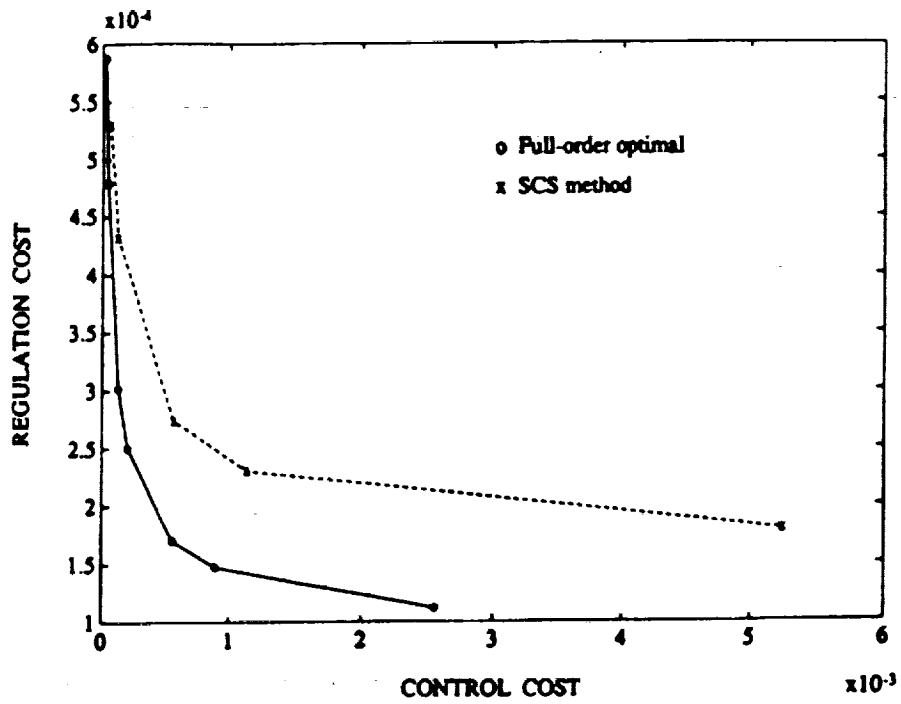

Figure 5: Performance plot of Case 2

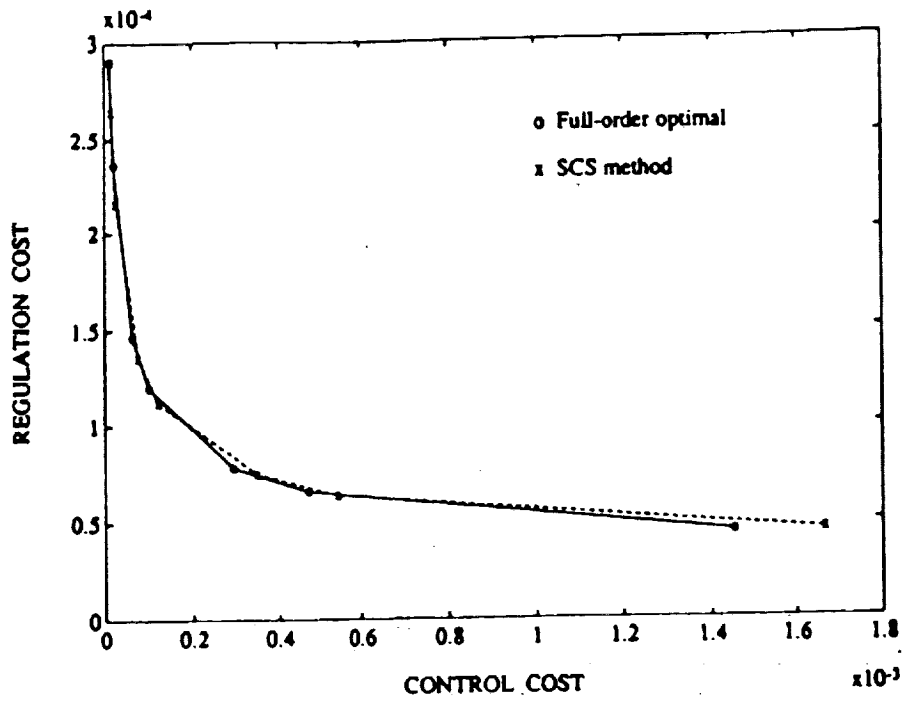

Figure 6: Performance plot of Case 3