

# Georgia Tech

THE GEORGE W. WOODRUFF SCHOOL OF  
MECHANICAL ENGINEERING

Georgia Institute of Technology  
Atlanta, Georgia 30332-0405

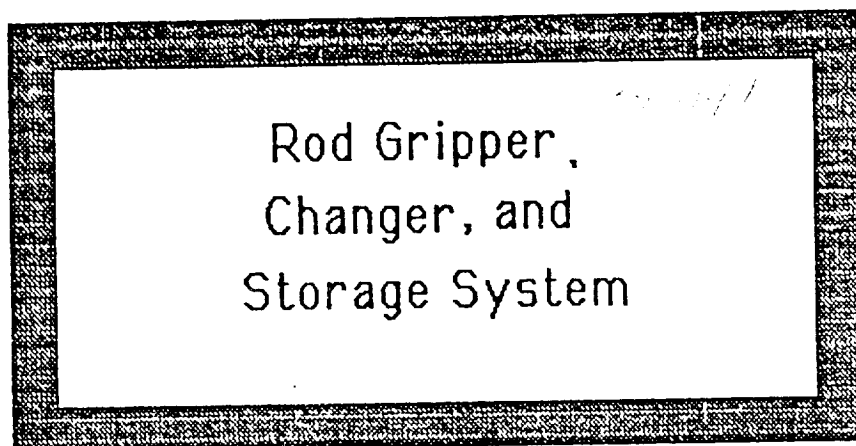

ME 4182 Final Report  
March 8, 1989  
Mr. James W. Brazell

Team Members:  
Mark Benson (Group Leader)  
Todd Demi  
Robert McNeill  
Keith Waldo  
Alex Afghan  
Jim Oliver

ROD CHANGER AND STORAGE RACKS SYSTEM

SKITTER'S  
FORNT VIEW

GRIPPER  
ASSEMBLY

SKITTER'S  
SIDE VIEW

STORAGE RACK

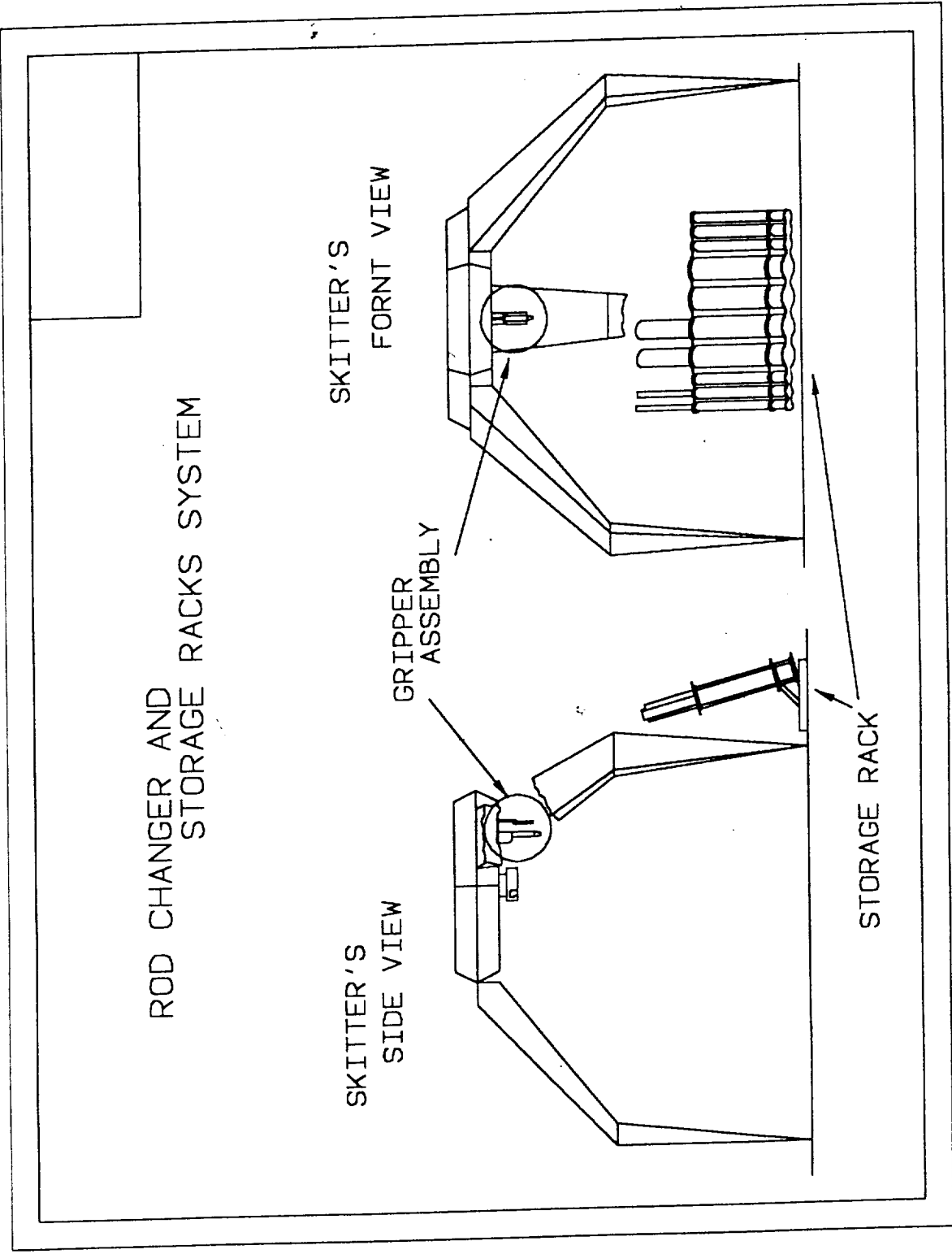

## Table of Contents

Abstract.....	1
Problem Statement.....	2
Description.....	3
Analysis	
Linear Transport Mechanism (LTM)	
Introduction.....	7
Description.....	10
Materials.....	20
Lubrication Analysis.....	22
Construction.....	23
Indexing System	
System.....	25
Operation.....	26
Manufacturing and Assembly.....	27
Materials.....	28
Alternatives.....	30
Rack	
System.....	31
Performance.....	32
Weight and Inertia.....	33
Failure.....	33
Materials.....	33
Overall Cost Analysis.....	34
Operating Procedure.....	35
Recommendations.....	37
Conclusions.....	38
Bibliography.....	39
Appendix	
A. Calculations and Figures	
B. Drawings	
C. Alternative Designs	

## Abstract

This report presents a rod changer and storage design for the lunar deep drill apparatus to be used in conjunction with the "Skitter" walking platform. The design must take into account all of the lunar environment and working conditions. Some of these are:

1. The moon has one sixth the gravity of earth;
2. Temperature gradients can range from about -170 to 265 degrees Celsius;
3. Because of the high transportation costs, the design must be as light as possible;
4. The process must be remotely operated (from earth or satellite) and must be automated.

Because of Skitter's multiple degree of freedom movement, the design will utilize Skitter's movement to locate an implement and transport it from the rack to the drill string. The implement will be gripped by a thumb and two finger device, identified through an electronic sensing device on the thumb, and transported from the rack to the footplate and back from the footplate to the rack. The major designs discussed in this report have been broken down into three major areas:

1. Gripper Design (Linear Transport Mechanism)
2. Indexing System
3. Rack Design

**Date:** January 25, 1969

**To:** Mr. Brazell

**From:** ME 4182D - Rod Changer and Gripper  
Todd Demi, Mark Benson, Jim Oliver, Alex Afghan, Keith Waldo, Robert McNeill

**Subject:** Project Statement

### **Abstract**

We will design the necessary components to store, index, and account for drilling rods and tools in a lunar surface environment.

### **Background**

This project grows out of work done previously which indicates that drilling will be a necessary function on the moon. The scope of our project is limited to the design of a rod changer mechanism, an indexing and accounting system, and the design of a storage rack.

### **Performance Objectives**

The following are performance goals which our design will meet.

- \* The rod changer and storage system will be able to handle rods and casings capable of drilling holes of 50 and 100 mm in diameter.
- \* These rods will have a maximum indexed length of 2 m.
- \* This system will withstand the moon environments effects with little or no maintenance for a period of 10 years.
- \* A reasonably short cycle time will be a major design goal so that deep holes can be drilled in a reasonable time.

### **Constraints**

Several constraints which govern our design are.

- \* The lack of atmosphere and the moon's reduced gravity.
- \* The need for minimal weight and a compact package because of high delivery costs.
- \* Extreme reliability due to the lack of maintenance available on the moon.
- \* The three second time lag in earth/moon communication should be taken into account.

## Description

### Gripper Design

All of the moving parts required for our project are encompassed in the gripper design. The major concern with the design of the gripper was the minimization of the number of moving parts while at the same time having the ability to grab several different objects with little deflection. A gripper design which utilizes a central thumb and two linearly moving fingers was decided upon. The central thumb provides support and carries most of the lifted load. The thumb also houses the indexing wiring and sensors. A hook is fixed to the end of the thumb in order to carry the heavy load of a full rack. Two fingers were needed to provide a positive grip and prevent rotation of the lifted implement. The linear motion for the fingers will be provided by a stepper motor which will in turn drive a power screw through a set of reduction gears. The screw will in turn move a traveler along two rigid rails. These rails insure that the motion is confined to one axis. The traveler which rides on the rails supports an inverted V shape which holds the fingers. On the ends of the V, are two fingers which distribute the load from the support mechanism to the lifted implement.

### Thumb Design

The thumb design incorporates the three functions of lifting and identifying each implement while also having the ability to lift a full rack of implements. The thumb is basically a cylinder with a hook on the end. Embedded in the cylinder are

the contacts to check the resistance in the rings for the indexing system. There is a second cylinder of a larger diameter which serves many functions. This cylinder serves as an enclosure for the LTM. Additionally, this cylinder helps distribute the torque load generated when lifting the rack. At a specified distance up the thumb, there is a limiting microswitch which is coupled to Skitter's control system to stop decent and to actuate the gripper.

### Indexing Design

The indexing system consists of a series of eleven contactors on the outside of the thumb. These in turn make contact with rings of either zero or infinite resistance on the inside of the couplers on each implement. By passing a current through these rings, the presence of an infinite or zero resistance can easily be detected. This data is then fed through a Schmidt Trigger to eliminate false highs or lows. The signal is then processed through a filter to eliminate the possibility of noise interference and then fed into a buffer. The registers in the buffer are then read by a microprocessor and translated into a 5V digital binary code for comparison with stored records. Each implement also has two parity bits to insure proper positioning of the thumb detector. The conducting material selected for the rings is EC grade Aluminum. The insulating material for the indexing system is Alumina ( $Al_2O_3$ ).

## Rack Design

The rack design incorporates no moving parts. The rack is tilted at an angle of 15 degrees so that there only have to be legs on one side. The tilt also insures that the rods and implements will always be held by gravity in the same position. The rack will consist of a series of tubes coupled together by a flared tip support plate and a reinforcing bottom half plate. These tubes are two thirds (1.32m) of the length of the implements so as to minimize the weight, but still provide proper positioning of the implements. The upper ends of the tubes are flared to meet the stamped shape of the upper top plate and to make it easier to insert the implements. The bottoms of the tubes are open to prevent contamination buildup. There is only one retaining strip to hold the implements. The legs will be tubular for maximum strength and minimum weight. There is a link to carry the torque of the rack to the legs. This link connects the lower reinforcing half plate to the legs. The rack material is an Aluminum alloy (Al2219-T37).

## Fabrication

The fabrication techniques will all be standard practices recommended for the particular material. In general welding will be preferred to bolting or press fits. This practice will minimize the effects of the vast temperature gradients. Additionally, bolts are not readily available in the exotic materials which we are considering. Bolts of other materials would add weight and due to varying coefficients of thermal expansion would cause unsurmountable problems in our close



tolerance design. Press fits would not hold up under the extreme temperature differences and the large number of thermal cycles.

## Introduction: Linear Transport Mechanism(LTM)

The need for a gripper capable of lifting various drill-impliments called for a design that is simple, efficient, and durable. After evaluating several concepts, the "Linear Transport Mechanism" was selected as the design that best suited the design requirements. Unlike the "Four Bar Linkage" that was initially considered, the LTM provides motion that is completely linear and uniform. The Linear motion is accomplished by mounting the Gripper "fingers" on a platform that slides on two cylindrical rails. The rails are to be mounted to a frame which will be the "Base" of the LTM.

The motion of the platform is provided by a Power Screw mechanism aligned with the platform's central axis. The Power Screw is rotated by a digitally controlled stepper motor. The rotation of the Power Screw shaft translates rotary motion into linear motion. The Stepper motor is connected to the Power Screw through a series of spur gears. It would have been possible to eliminate gears entirely by coupling the drive motor directly to the Power Screw, however space limitations prevented such a design. It was possible to achieve an immense gripping force by a large gear reduction ratio, however the cycle time of the entire gripping operation became too long.

By using a Linear Transport Mechanism, the gripping operation is a completely digital process. Control of the LTM can be accomplished by the Skitter's control mechanism's without the Analog to Digital conversion typically required by the generic "robot grippers" commonly found on Earth. The LTM also eliminates the necessary feedback devices that a "four bar linkage" gripper would require. The geometrical motion of the Four Bar Linkage(FBL) pre-

sented a conflict with our design parameters. The path that a FBL mechanism follows is typically an arc.

This arc of the FBL mechanism provides difficulty for the Indexing System since not all implements have the same diameter and therefore the length of the movement for a particular implement (i.e. a Rod) is shorter than that of a Casing. Sighting these problems, the LTM was a more attractive alternative since it presented no such path discrepancy.

In addition to the geometrical considerations, the effects of the environment on the design, were a major concern. The FBL mechanism inherently calls for an "outside" design. That is, it would be difficult to enclose the FBL mechanism from the environment. A build-up of Lunar dust in the linkage joints could lead to excessive wear and catastrophic failure. Small rocks could also jam the FBL design. The LTM design is however, capable of being entirely enclosed in a housing and therefore isolated from the environmental effects. The housing to enclose the LTM provides:

1. Resistance to Contamination
2. Insulation from severe temperature gradients (the LTM will spend its' life in the 'shade') therefore it will experience heat transfer only by conduction.

Other factors that influenced the decision process in support of the LTM was a need to enclose the moving parts away from the Lunar environment. Contamination of joints could lead to catastrophic failure of the LTM mechanism. The LTM will be enclosed in a cylindrical housing that will provide two important functions: 1) Isolation of the

LTM from the hazardous aspects of the Lunar environment  
2) a structurally stable 'platform' that will transmit  
dynamics loads generated during the drilling process.

## LTM

### Description

The Linear Transport Mechanism (LTM) will be mounted inside of a cylindrical housing that is located on the underside of the Skitter Lunar Transport Vehicle. The LTM will be comprised of several components:

1. Base
2. Slider
3. Power Screw
4. Rails
5. Stepper Motor
6. Fork
7. Fingers
8. Bearings
9. Gears
10. Motor Mount

#### Base:

The Base of the LTM will be constructed out of 5mm. thick Aluminum (AL #2219-T37) plate. The Aluminum plate must be cut to the proper dimensions:

- (2) 160mm. x 38mm. Al plates
- (2) 110mm. x 38mm. Al plates

The plates must have the required holes drilled in them to provide the geometry necessary for the support of the Rods, Power Screw, and Bearings. The hole sizes are:

- (2) 11mm. Diameter holes
- (1) 20mm. Diameter hole

See the Instruction Sequence in the Appendix for more details on the actual assembly of the Base. The Base will provide support for the entire Gripper/LTM assembly, therefore its strength is critical in order to prevent failure of the mechanism (see Appendix A for analysis).

Environmental effects:

Radiation on the moon is a large design problem because of the fact that there is no atmosphere. Thus any radiation (UV, IR, etc. ) that reaches the moon immediately hits the surface. Radiation tends to break the atomic bonds of all the materials being used on Skitter. Thus the materials tend to weaken over time. However, the annealing of metals such as aluminum tends to provide protection. All metals in our design are annealed for this purpose.

In order to protect the inner components of the LTM from dirt, a vinyl ester sleeve is placed in the slot that the arm will travel through. Vinyl ester itself is radiation resistant.

Aluminum 2219-T37, our main structural material, is highly resistant to temperature gradients. It keeps its strength properties at temperatures up to 600 degrees fahrenheit and

as low as -225 degrees. This temperature resistance provides the needed protection on the Moon. The ceramic we are using, ( $\text{Al}_2\text{O}_3$ ), is good at all operating temperatures. The same is also true for the vinyl ester (Ashby and Jones).

## **Description**

### **Slider Mechanism:**

The design of the LTM calls for the Gripper's fingers to be mounted rigidly to a "slider" mechanism in order to provide a linear motion for the Fingers. The slider will be constructed from an Aluminum block that will be machined to provide hollow shafts for the rails and the Power Screw. Specifically, two holes are to be drilled in the block with a diameter of 16mm. each. The third hole will be drilled with a diameter of 23mm. This diameter allows for threads to be cut into the block with a thread height of 1.5mm. The Power Screw will be threaded into the block's 23mm hole, thus providing the required transformation of rotary motion into linear motion.

### **Stepper Motor :**

In order to convert rotary motion into linear motion, a Stepper motor will be used to rotate the Power Screw. The Stepper motor is unique in that it is driven by a series of



digital pulses instead of the conventional motor's constant current field. The decision to use a Stepper motor over other more conventional motors was based on several factors;

1. Precise control capability
2. Low power consumption
3. Variable Speed Capability

The Stepper motor is far superior to conventional motors in its ability to be precisely controlled. The Stepper motor in effect "counts" the digital pulses it receives and translates each pulse into a corresponding shaft movement.

The high-resolution stepper motor uses a 1.8 degree per pulse increment: For each pulse input to the motor, the output shaft is rotated by 1.8 degrees. Therefore, by controlling the total number of pulses and the number of pulses per second, control of the Stepper motor is achieved. There are numerous digital control circuits already developed for the control of Stepper motors. Therefore we have neglected any further considerations for such.

#### **Gears:**

The gears used in the transfer of power from the stepper motor to the power screw are two(2) spur gears with a 70mm. diameter. The function of the gears is to provide power

transfer from the motor to the power screw at ten(10) rotations per second. One gear is welded directly to the motor shaft and the other is welded directly to the power shaft. See gear calculations in Appendix A.

#### **Screw:**

The power screw used to move the slider is a 20mm. outer diameter shaft. The main function of the power screw is to translate the rotary motion of the motor to translational motion of the slider. The screw sits in the bearings on the end of the screw (Appendix B6). The screw is of a fine pitch(1.5mm.). Its treads are square and lubricated by Teflon. There is a certain amount of torque loss in friction but is more than accounted for by the fact that the needed torque is 2.5 N-m and the provided torque of the motor is 25 N-m. The travel of the slider is approximately 70mm. The slider will be able to travel this distance in 4.7 seconds.

#### **Fingers:**

The fingers are made of etched Aluminum 2219-T37. They are cylinders with a diameter of 18mm. and a length of 80mm. The fingers will provide approximately two-thirds of the load capacity. The total load capacity of the entire system is 265 newtons; therefore, each finger will support approximately 88 newtons.

**Arm (finger support):**

The transmission of the gripping force from the Slider mechanism to the "thumb" of the LTM will be accomplished by the use of two fingers that are suspended from the Slider mechanism below the Base of the LTM. The design goal of the "Arm" support was to provide a lightweight, strong, assembly that allows the fingers to be moved in a linear fashion. This linear movement will allow the fingers to provide a firm, steady gripping force. In order to assure proper identification of a drilling implement, the gripping action must provide smooth and even application of the gripping force and provide enough force to insure that the drilling implement is not dropped during loading and retrieval.

**Rods (slider supports):**

The ability of the LTM to provide a linear motion is based on the design of a "linear sliding mechanism." To accomplish this type of linear motion, the slider must have supports that will provide adequate strength for the lifting operation and still allow for a smooth linear action. The supports will be constructed out of 10mm. diameter Steel rods. Specifically, ASTM #A242 hardened steel. The selection of steel was influenced by the need for a strong load bearing material with a low coefficient of thermal expansion and high strength. The steel rods should be

polished to provide as smooth and friction free surface as possible.

#### Motor Mount:

The stepper motor that drives the LTM requires a suitable mount. The design of the mount reflects the space limitations imposed. The mount is constructed out of five(5) milli-meter thick aluminum Al2219-T37 plate. The plate must be cut to the proper dimensions and have the five(5) holes drilled (see Appendix B8). The mount will be seam welded to the top of the Base assembly. This arrangement allows the LTM to have the maximum amount of linear travel in the smallest possible space (see Appendix B6 ).

## **Bearings:**

The use of the Power Screw in the Base assembly called for a bearing to support the screw shaft at each end of the frame. The selection of an appropriate bearing material was based on the PV characteristics for several different materials (see Bearing analysis in Appendix A19). The PV factor is a measure of how much frictional heat is generated in the bearing due to load, RPM, and size. The choice of an Aluminum, sealed, caged, ball bearing best satisfied our design requirements. The other material considered for our design were:

**Bronze** - The most common bearing material. 90% Copper  
10% Tin. Good wear resistance, ductile, good  
corrosion resistance, low cost.

**Copper Iron** - High compression strength but poor high  
speed characteristics. Good for heavy load  
applications.

**Iron** - Low cost, good strength (but low PV factor)  
high porosity, good wear resistance

**Leaded Iron** - Improved speed capability, low cost

**Aluminium** - Cool operation, greater misalignment  
tolerances, **LOW WEIGHT**, longer service  
than bronze, High PV, High cost

The important factors in selecting a suitable material  
for our application were:

1. Weight

Bearings(con't)

2. Life

3. Strength

Although the initial cost for the Aluminum Bearings is much higher, These costs will be offset when the transportation costs are analyzed. The weight savings realized by using the Aluminum bearings are critical.

## LTM

### Materials

The design and construction of the Linear Transport Mechanism (LTM) presented many options for material selection. The two primary criterion considered when choosing a suitable material, were:

1. Weight
2. Strength

The LTM mechanism is required to provide a reliable operation for over 40,000 operations. The LTM will be forced to endure impulse loads of 300 to 400 N-m for short periods of time. Therefore, strength of the mechanism is of primary concern. The LTM must be capable of providing the necessary motion without failure. The use of strong lightweight materials such as Aluminum 2219-T37, provide the best strength to weight ratio. The decision matrix for material selection(Appendix A2) shows that several materials were evaluated and eliminated based on several factors (Temperature, radiation, coefficient of thermal expansion, lack of pressurized environment, etc.).

The majority of the LTM will be constructed out of Aluminum 2219-T37. This material was chosen because of its

excellent properties when subjected to the Lunar environment. Other materials used in the LTM are:

Base(LTM): 5mm. thick Aluminum 2219-T37 plate

Slider(LTM): Aluminum 2219-T37 block

Motor Mount(LTM): 5mm. thick Aluminum 2219-T37

Support Rails(LTM): 10mm. solid cylindrical  
ASTM #A242 Steel Rods

Forks(finger supports): 16mm. Square Aluminum  
2219-T37 Tubing

Fingers(LTM): 30mm. Cylindrical Aluminum 2219  
T37 Tubing

Finger Tops: 5mm. thick Aluminum 2219-T37  
plate



## LTM

### Lubrication Analysis:

The use of lubricants in a hard vacuum presents many challenges that are not faced when designing for the Earth environment. The LTM uses a sliding action to allow for the "linear motion". Therefore, the interface between the slider and the rods requires a lubricant to prevent seizing of the mechanism. The first consideration was to use conventional lubricants, however, the lack of atmospheric pressure and severe thermal gradients precluded their use. Much research has been done on the subject of lubrication in extreme environments.

Microseal(trademark) is the name of a type of process developed specifically for space applications. Actually, Microseal is a process which deposits a thin film coating of a solid lubricant that creates a continuous lubricating surface. Microseal remains effective in extreme temperature fluctuations (-423 to 2000+ degrees F). The Microseal is not affected by shock, radiation, vibration, or electrical noise interference. The actual lubricating material is Molybdenum Disulfide that is sprayed onto the material by a high pressure application system.

Note: Microseal is a trademark of the E/M corporation.

## Construction of the LTM

### Preparation:

Slider -	Drill Holes Cut Threads
Frame -	Cut Material to Size Drill Holes
Power Screw -	
Motor Mount -	Cut Material to Size Drill Holes
Housing -	Cut Material to size

### Assembly:

- Base -
1. Cut Material to Size
  2. Drill Holes in End Pieces
  3. Weld Frame Together
  4. Insert Rails and Slider Ass'y
  5. Weld Rails in place
  6. Thread Power Screw in place
  7. Press Bearings in place
  8. Weld Screw to Bearing's I. R.
  9. Attach Gear (collets or weld)

### Motor Mount:

1. Weld parts together
2. Install Motor (bolts)
3. Install Gear to Motor Shaft

Considation: The completed base assembly should now be joined to the Motor Mount assembly by a Seam weld around the periphery of the Base.

## Indexing System Analysis

### System

As stated in the description, the indexing system will require both a sensor located within the thumb and a series of rings inserted within the inner diameter of the rods.

Sensor: The drawing and dimension for the sensor insert is shown in Appendix B.12. It will be located within the thumb as shown in Appendix B.13. The sensor will have the same geometry as the inside of the hollow thumb and the 75 x 12mm section that is machined out of the thumb for the sensor's face. There is a 0.5mm clearance between the ceramic sensor and the aluminum thumb to allow for different thermal expansion rates. The 3 x 3mm contactors will protrude approximately one millimeter out of the ceramic body of the sensor and will be connected to the circuit wiring located within the hollow center of the sensor body. The contactors on the right side will all be connected to a common voltage wire, while each contactor on the left will have a separate lead to a Schmitt Trigger that will be able to sense which circuits are completed, convert the information into a binary code, and send the signal to the microprocessor. This basic circuit is shown in Appendix B.15.

Implement Rings: A series of rings will be inserted into each rod of implement as shown in Appendix B.14. Although the actual coupling for the implements has not been designed, the dimensions or the coupling have been chosen here to include a 35mm O.D. and a 27mm I.D.. The I.D. will be machined out to a 30mm I.D. at a depth of 76mm to allow the insertion of 25

rings, 3mm in length (this allows 1mm total clearance to allow for different thermal expansion rates). A ceramic insulating ring will be located between each of the eleven rings that are actually used in the identification circuit. There will also be three insulating rings at the opening of the rod to allow for proper alignment with the thumb sensor.

### Operation

Each implement will be identified when it is first gripped by the LTM. The thumb will be inserted into the implement coupling until the flange above the sensor is reached. At this point the contactors will be aligned with the circuit rings in the implement and the LTM will grip the implement.

To avoid false readings, the first and last set of contactors will be the test contactors, whose corresponding rings will be a conducting material on every implement. If the two test contactors have both completed a circuit, then the other nine set of sensors are in contact and in the correct location. If either of the two test circuits are not completed, a "false reading" message will be sent to the operating microprocessor and the LTM will adjust its grip (to remove debris between the implement and the thumb flange, align the gripping angle, or correct whatever other problem causing a false reading).

Each implement will have a different arrangement of conducting and nonconducting rings in the remaining nine sensor locations. When an implement is properly gripped, the microprocessor will be able to sense which circuits are completed (which sets of contactors are connected to

conducting rings), and which circuits are not completed (which contactors are connected to non-conducting rings). The signal will then be converted into a nine digit binary code which will identify the rod presently being gripped. The nine digit binary code allows for a possibility of 512 different implements. The microprocessor will be able to keep track of which implements are in the drill string, which ones are in the rack, and how many times each implement has been used (to avoid fatigue failure).

#### Manufacturing and Assembly

The exact manufacturing process of the indexing system parts is beyond the scope of this report, but the methods had to be taken into account in the design of the parts. Following are some considerations that were taken into account.

Sensor: The ceramic body of the sensor will be cast with the contactors and wiring already in place (the contactors must be firmly implanted within the ceramic body because they will be taking a large portion of the gripping load). The wiring can consist of actual insulated copper wires, or a series of flat printed circuit board type strips running up the inner wall of the sensor body.

To assemble the sensor within the thumb, the thumb must at first be constructed of two parts: (1) a hollow 4mm thick tube with a flange and a 12 x 75mm section machined out for the sensor face, and (2) a solid cylinder bottom piece (that includes a hook for picking up the rack). The sensor assembly must be placed within the hollow tube with the wires running out into the LTM housing and from there to the trigger and

skitter microprocessor. The bottom solid hook piece must then be welded to the upper thumb tube and sensor assembly. The hook piece must have a 45 degree bevelled surface to allow for a proper butt weld to the tube and sensor assembly.

Implement Rings: Each ring should be manufactured the same way a common O-ring is made. The method of retaining the rings within the implement coupling depends on the material of the implement. If the implement is aluminum or another type of metal, it should be machined to the larger I.D., the rings should be inserted in the proper order, and a flange or pin should be welded or coupled to the top of the implement to keep the rings from being pulled out. If the implement is non-metallic, the rings could possibly be adhered to the inner wall with an epoxy that will perform in the large lunar temperature range.

### Materials

The task of selecting materials for the indexing system was accomplished by comparing and evaluating a series of mechanical and physical properties of different available materials. Some of the information used in the selection of materials is shown in Appendices A.2 through A.8.

Taking the effect of temperature and radiation as the two most important factors into account, the choice for conducting materials (to be used in the rings on the inner surface of the implements and for the contactors) is aluminum alloy. There are several properties that set aluminum apart from other metals. First, it is lighter than all other engineering metals except magnesium and beryllium; it has a density of

about 0.1 lb/in<sup>3</sup>. The second important property of aluminum is its thermal and electrical conductivity. It has about 60% of the conductivity of pure copper but because of its lower density, aluminum has higher conductivity than copper per unit mass. The mechanical properties of aluminum are also important. Some of these properties are: high strength to weight ratio, good formability, high reflectivity, and aluminum is nonmagnetic and nontoxic. Among the different aluminum alloys, taking the property of electrical conductivity as the most important factor, the EC(electrical conductor) grade aluminum alloy was found to best fit this application (see Appendix A.7).

The choice for non-conducting material has to be chosen from two groups of materials: polymers or ceramics. Ceramics are known to be resistant to radioactive environments because of the strong bonding force between atoms. Because of the adverse effects that the radioactive environment and the wide temperature range (-173 to 265 deg. C) have on polymers, a ceramic was chosen as the non-conducting material.

There are several important electrical properties that have to be considered when choosing an insulating ceramic: dielectric strength, dissipation factor, dielectric constant and volume resistivity. Comparisons were made between several ceramics and the choice is Alumina, Al<sub>2</sub>O<sub>3</sub> (see Appendix A.3). The physical and mechanical properties of Alumina are particularly suitable for applications such as electrical and thermal insulation.



## Alternatives

The decision of using electric contactors on the thumb and a binary code of conducting or non-conducting rings within the implement coupling came from combining the concepts from two other design ideas.

The first idea consisted of a series of spring loaded buttons on the thumb and a binary code of machined out indentations within the implement coupling (see Appendix C.6). This design would probably not be durable enough for automated operation on the moon.

The second idea consisted of (an) actual resistor(s) inserted within the implement coupling and one or two sets of contactors on the thumb (see Appendix C.8). Each implement would have a different resistivity and the skitter microprocessor data base could then identify the implement being gripped. This design had problems of changing resistivity with large temperature gradients and the actual locating of the resistors within the implement coupling.

## Rack Analysis

### System

The rack system consists of a series of coupled tubes. These tubes are made rigid and supported by plates through which the tubes pass. The rack is supported by a pair of legs that extend on one side. The racks can be stacked in a manner very similar to the way in which chairs are stacked. To fix the position of the implements, the rack is tilted at an angle of 15° to let gravity hold the implements in place. By tilting the rack, its weight is also reduced because legs are only required on one side of the rack to keep it upright.

Tubes: The tubes are made of the Aluminum 2219 alloy 1 mm thick. These tubes are two thirds the length of an implement (1.32 m). The top ends of the tubes are mated to the top reinforcing plate to provide rigidity. Appendices B 62,65, and 68 show the various tubes which are required to hold the various sizes of implements.

Top Plate: The top plate is stamped from a 2 mm plate of the same aluminum alloy. The holes which mate with the tubes are flared to make implement insertion easier. There is a turned down lip around the perimeter of the plate to provide more flexors rigidity under the load of a full rack. The top reinforcing plate can be seen in Appendices B 60,61,63,64,66, and 67.

Lower Plate: The lower reinforcing half plate is located 680 mm below the top reinforcing plate. This plate is also stamped from 2 mm thick plate stock of the aluminum alloy. This plate provides a structural component to which the leg reinforcing link and the lifting extension arm can be mounted.

Lifting extension arm: The lifting extension arm (Appendix B 69) is connected between the upper and lower reinforcing plates. The location of the handle is such that the center of gravity of a full rack is located directly below the lifting hook so as to eliminate the moment which could result. The racks should be placed at the job site and used and moved again only when full. Each rack has a slit in the middle through which the extension arm of a mating rack can pass so that the racks can be close packed for storage and transportation.

Legs: The legs are made of 2 mm thick aluminum alloy tubing 30 mm in diameter. The legs do not extend past the horizontal projection of the tubes. The legs are spread at an angle so as to accept another pair of legs in front of them from a conjointly stacked rack in storage. The legs are fitted with a conical leg projection and a surface plate. The cone penetrates the lunar surface to hold the rack in position while the plate limits the depth to which the rack can settle. Both of these accessories to the legs are fabricated from 2 mm plate stock: the cone being rolled to shape and the plate being used as is.

Leg Link: The leg link is a reinforcement which connects the legs to the lower reinforcing half plate. The purpose of this link is to carry the torque load which results from the inclined angle of the rack.

## Performance

Several basic parameters have been identified as the key to a successful rack design. The function of the rack is to hold the implements in such a manner that their position is fixed. Additionally, the implements should be able to be placed and removed easily. Our rack design should also be very durable while having a minimum weight and a compact design.

## Weight and Inertia

The weight of the rack has been estimated to be less than twelve pounds (moon).

## Failure

The points of the highest stress on our rack are the pivot point where the tubes are joined to the legs. Additionally, The retaining strip at the bottom of the tubes will receive large stresses in addition to supporting almost the entire weight of the particular implement. We are assuming that even though Skitter has very accurate motion, sometimes its motions are not smooth and thus our rack could receive some impact loads.

## Materials

An Aluminum-Copper alloy was selected for the structural members of the rack system. The alloy, designated Aluminum 2219-T37, has been used in space applications before and meets the weight, strength, and temperature range resistance requirements. Since the same material is used to construct all rack components, welding is the preferred means of joining. Good welding practices should be followed in all applications. Welding will eliminate the effect of varying coefficients of thermal expansion. The aluminum should be annealed so as to minimize the effects of the intense solar radiation. The effect of the solar radiation is to increase the energy in the system. This is accomplished by generating disorder in the aluminum in the form of dislocations. The effects will tend to make the aluminum brittle and cause pitting.

### OVERALL COST ANALYSIS

Due to the high cost of transportation of the materials to the space, the overall cost analysis is primarily based on the total weight of the design. There are basically three components to consider for the weight analysis :

1. LTM
2. Thumb and sensor
3. Racks

The following table demonstrates the weight of each group and the estimated cost for the transportation to the space:

COMPONENT	WEIGHT (lb)
LTM	13.08
THUMB & SENSOR	0.50
RACKS	145.08
TOTAL WEIGHT : 158.66 lbs	

The total weight of this design is 158.66 lb and assuming the cost of transportation to the space to be \$100,000 /lb, the total cost for transporting the complete design system to the space would be \$15,866,000.

## Operating Procedure

### 1. Site Preparation

- a. Clear loose and broken rock.
- b. Position Skitter at Pre-Determined Coordinates to facilitate Rack and Dump-Truck alignment.
- c. Position Skitter over Dumptruck to facilitate removal of Rack.

### 2. Drilling Preparation

- a. Align the Gripper/LTM over the Rack's handle and open gripper.
- b. Lower Skitter to facilitate gripping action.
- c. Close gripper on Rack Handle, prepare for lifting of Rack.
- d. Lift Rack out of Dumptruck and place on pre-determined coordinates.
- e. Release grip on Rack and prepare for drill implement removal.
- f. Skitter's control system selects the first tool to be used for drilling.

### 3. Tool Identification and Placement

- a. Position Skitter over first drilling tool.
- b. Open gripper and lower Skitter over the desired tool.
- c. Close gripper and wait for confirmation from Indexing mechanism.
- d. If Indexing approves the identification of the tool, raise Skitter to facilitate removal from Rack.
- e. If Identification is not verified, cycle gripper and re-identify.
- f. With Identification complete and tool removed from Rack, re-position Skitter over intended drilling target.
- g. Lower Skitter over footplate mechanism.
- h. Position drilling implement into footplate's aperture.
- i. Confirm that footplate aperture has firm grasp on drilling implement.
- j. Release grasp on implement by Gripper/LTM.

### 4. Drilling

Note: The drilling sequence will be specified by the type of hole to be drilled, but will follow these basic steps.

- a. Lower Skitter over footplate so that the drill chuck is in alignment with the top

- of the drilling implement.
- b. Open drill chuck and lower onto drilling implement's coupler mechanism.
- c. Close drill chuck(perform 1/2 twist)
- d. Drill string is now capable of performing drilling operation.

#### 5. Removal/Storage of Implements

- a. Footplate aperture grabs drill string in preparation for implement removal.
- b. Drill chuck performs release maneuver(performs 1/2 twist) on coupler mechanism.
- c. Skitter raises up and places Gripper/LTM onto drilling implement's coupler mechanism.
- d. Skitter's control system activates LTM to Grip implement.
- e. Footplate's aperture mechanism releases grip on drilling implement.
- f. Skitter raises up and relocates Rack.
- g. Skitter aligns implement with Rack and lowers down.
- h. With implement in place, Skitter releases grip and the cycle is complete.
- i. Skitter cycles in this manner until drilling process is complete

## Recommendations

The proposed design was selected after first creating and considering many other ideas. Because of time constraints, the final design was not analyzed as completely and as thoroughly as is needed. A prototype of the design needs to be built and more thorough analysis and testing needs to be done. Below are some further topics that need to be analyzed for each part of the design.

LTM: Inertia of the system (gears, etc.), the actual friction coefficients of the metals, better joining techniques (welds, etc.), and accurate control of the screw rotation all need to be further analyzed.

Indexing System: Microprocessor design, the durability of the sensor contactors, interfaces of the ceramic and aluminum parts in both the implement rings and the thumb sensor assembly, and the manufacturing process of the thumb sensor assembly all need further analysis.

Rack: Because the rack has no moving parts, material selection is the key. Further study in new advanced light weight alloys with high strength to weight ratios could lower the weight and thus the cost of the rack system.



## Conclusions

Our thumb and gripper design depend heavily on the motion of Skitter. The design of our rack is such that it compliments the movements of Skitter. The indexing system has maximum reliability while allowing the identification of individual implements.

For simplicity, the gripper has movement in only one direction. By limiting the degrees of freedom and depending on Skitter for complex motions, we have minimized the weight while at the same time maximizing the reliability. The gripper hook will be able to lift the maximum load of a full rack with allowances made for entrapped contamination. The fingers can provide a positive lock and fix the position of the rack.

The indexing system has been simplified as much as possible. The measured parameter (resistance) is easily detected and the difference between zero and infinite resistance is obvious.

Minimum weight has been the governing design parameter with respect to the rack. Further study should be made into new materials in an effort to further reduce the weight. The racks are stackable so that minimum area is consumed in transporting them.

Our design does not particularly address special situations such as the dropping of an implement or damage to a particular system. To maximize the reliability, versatility had to be sacrificed. Low safety factors were selected so as to minimize the weight.

# Appendices

# Appendix A

## Calculations

2/16/89

ME4182 Group #2 Winter '89

DESIGN FEASIBILITY COMPARISON

Wt. Factor:	N/U	2	4	9	4	5	10	10	5	5	TOTALS
	Degrees of Freedom	Number of Moving Parts	Shipping Size	Power (# of motors)	Height (Cost)	Speed	Operating Size	Operating Reliability	Life Reliability	Environment Effect	
#1	1	0	5	7	5	3	4	1	1	1	140
#2	3	3.5	4	2	5	7	4	3	7	4	229
#3	3	1.5	4	1	4	6	4	3	6	2	192
#4	2	3.5	3	0	4	4	7	2	1	4	143
#5	1	5	5	4	6	8	4	4	2	1	197
#6	1	8	6	6	7	1	7	8	9	10	358

- #1 - Three Barrel Canister on Base
- #2 - Concentric Suspended Fixed Rack w/ Central Arm
- #3 - Revolving Canister on one side of drill, Arm on the other
- #4 - Pivoting Revolving Canister with no arm
- #5 - Fixed Revolving Canister w/ no arm
- #6 - Concentric Gripper on Drill Head, "Teepee" segmented Rack on Base \*\*

\*\* The concentric gripper design was later changed using the same concept, to the Thumb and Two Finger design which is much simpler.

Decision Matrix for basic structural material  
 -used for all structural elements unless otherwise indicated-

	X7	X5	X8	X9	X9	X5
	YIELD STRNTH.	ULT. STRNTH.	DENSITY	HIGH TEMP. STRNTH	LOW TEMP. STRNTH	COEF THERM EXP.
STEEL 1040 CD	10	9	3	7	7	8
AL 1060 H12	4	7	9	7	6	8
AL 2219 T37	7	3	9	10	10	8
FIBER COMPOSITE	9	8	10	1	3	2
S20100 ANNEALED STAINLESS	8	10	3	8	8	8

TOTALS:

FIBER COMPOSITE: 229 PTS.

ALUMINUM (1060): 272

STEEL (1040): 305

STEEL (20100): 314

ALUMINUM (2219): 376

From this matrix it is readily apparant that the 2219 Aluminum is better in a general case than the other materials.

DECISION MATRIX FOR THE INSULATING MATERIAL  
INDEXING SYSTEM

MATE- RIAL	X8 MODULUS OF ELAST.	X7 VOLUME RESIST.	X6 DIELEC. CONST.	X5 DISSIP. FACTOR	X5 DIELEC STRENGTH
MgO	8	8	6	3	3
BeO	9	9	7	7	7
Al2O3	10	9	10	8	6
PPS	2	10	5	8	7
DAP	4	9	6	7	10
EP/G	5	9	6	10	7

TOTAL POINTS :

MgO = 186 PTS

BeO = 247 PTS

Al2O3 = 273 PTS

PPS = 191 PTS

DAP = 216 PTS

EP/G = 224 PTS

This comparison was mainly based on important electrical properties and the obvious choice is of course , Alumina , Al2O3.

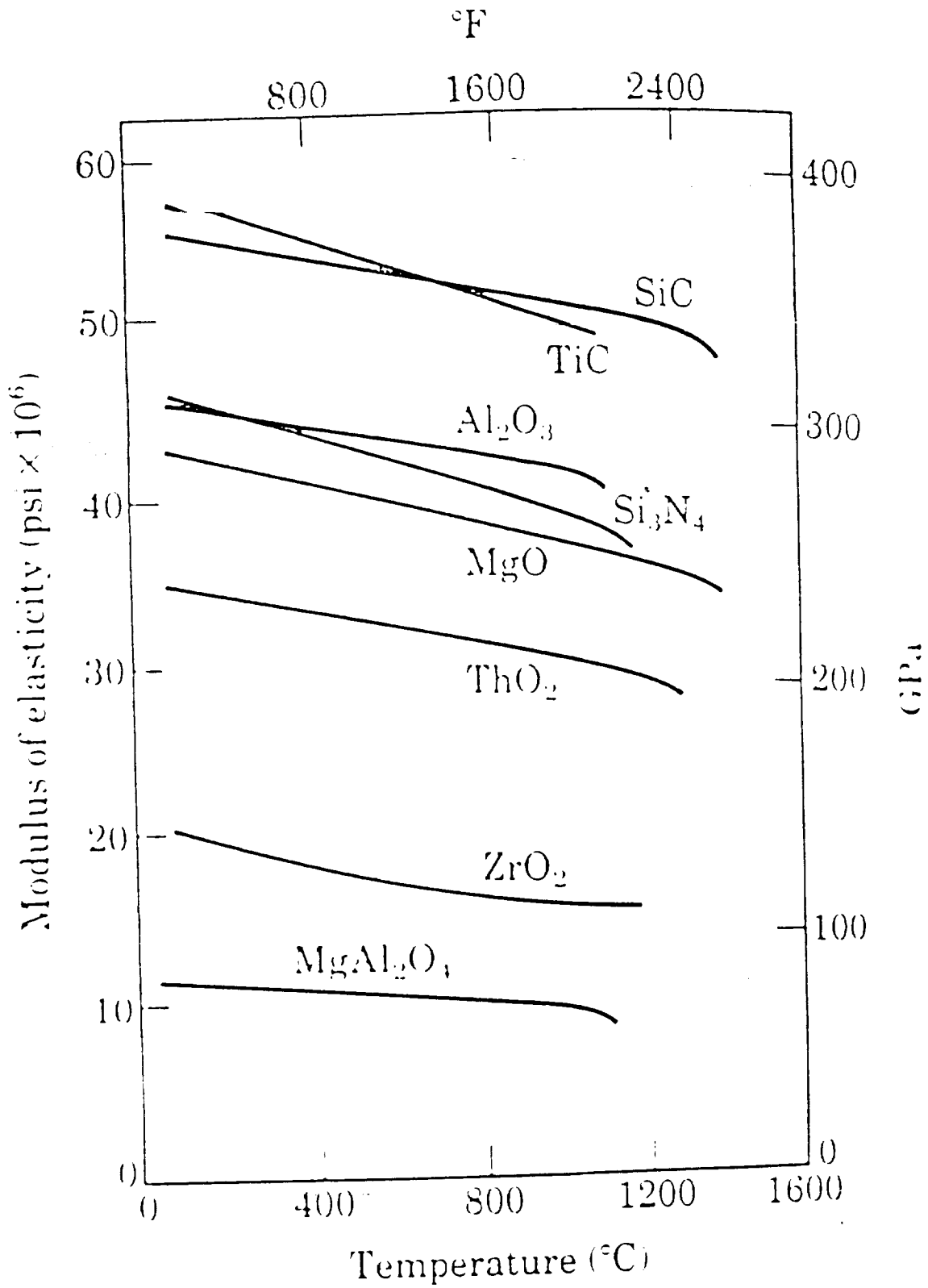

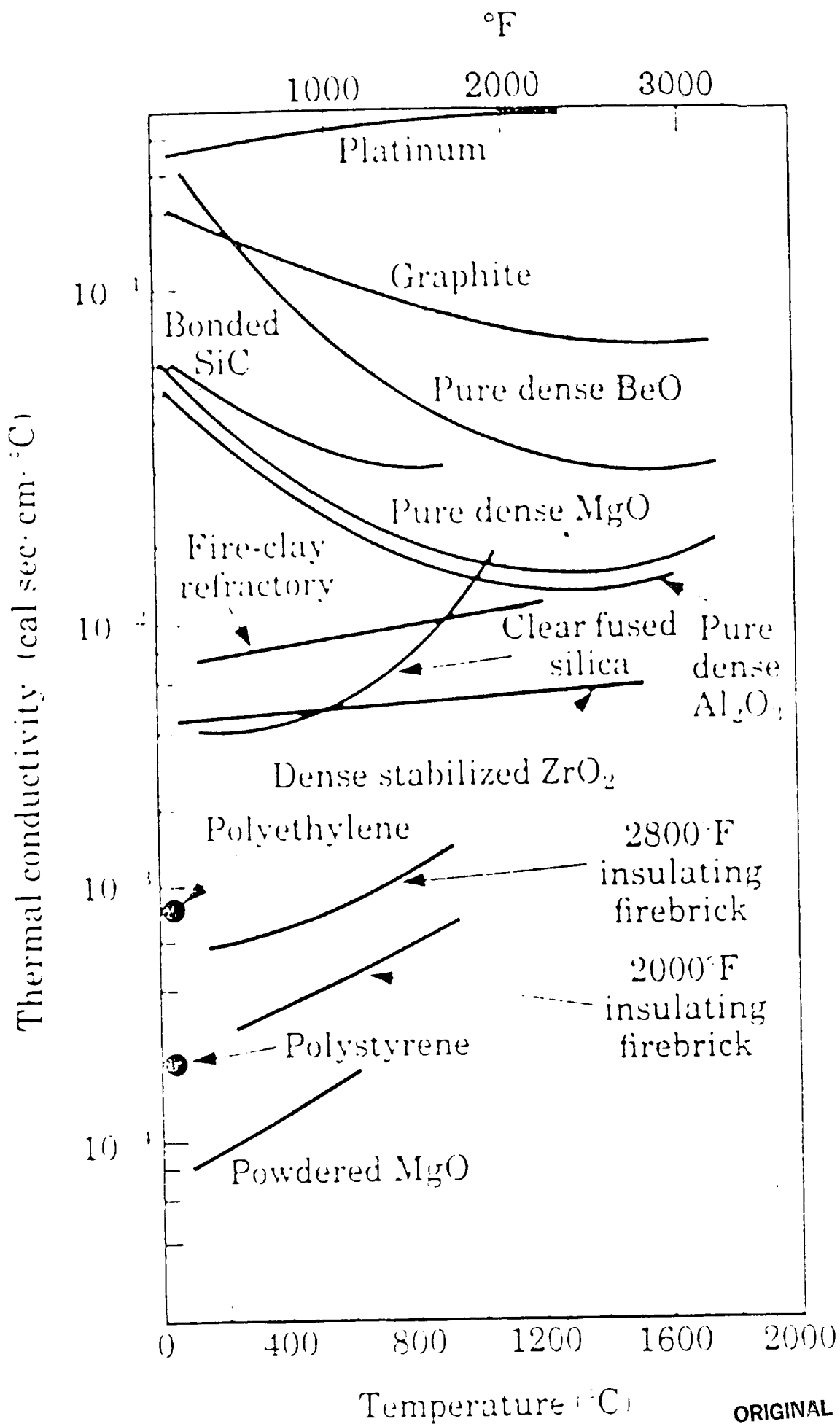



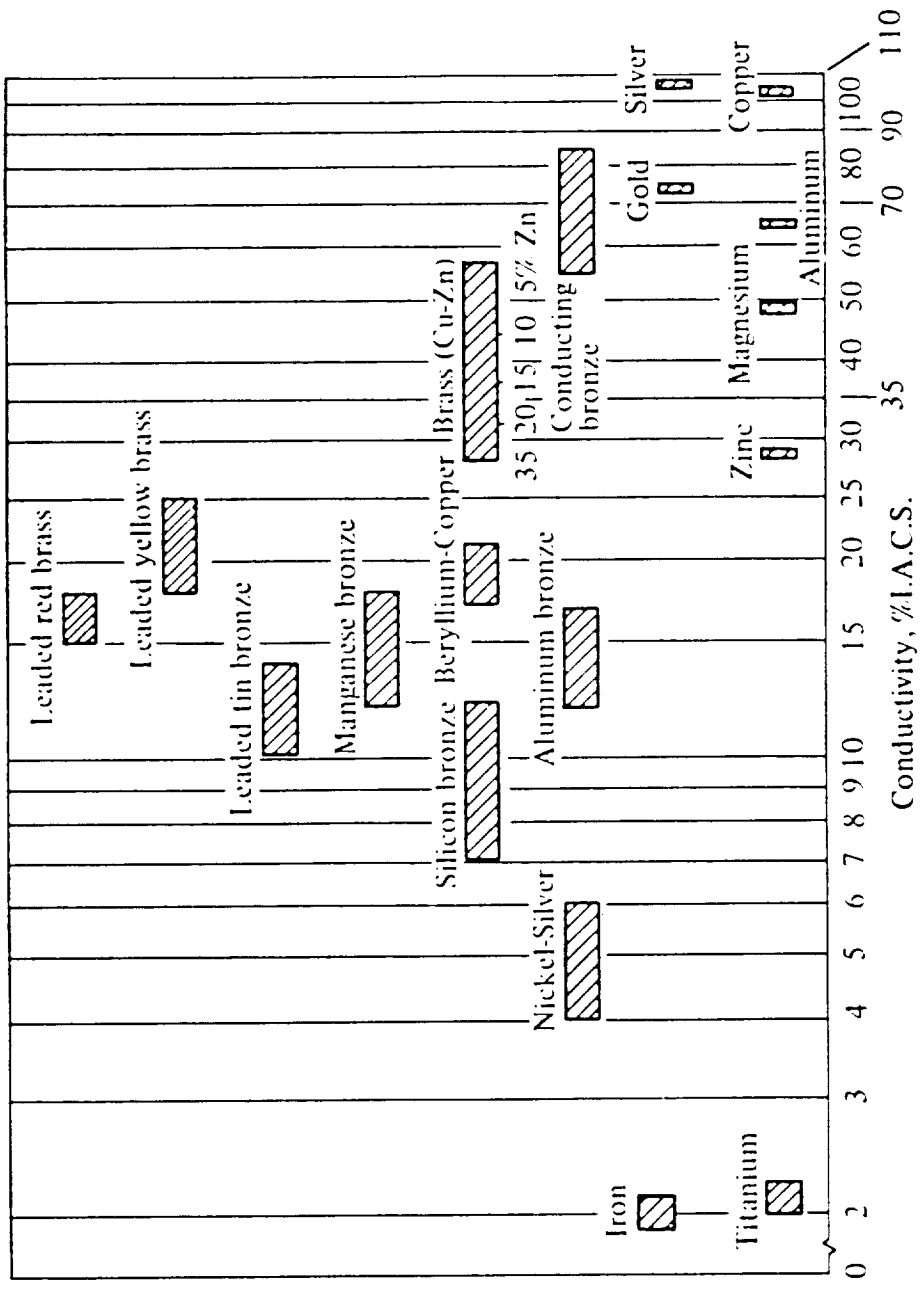

Conductivity of common metals and alloys in terms of percentage of the international annealed copper standard

ORIGINAL PAGE IS OF POOR QUALITY

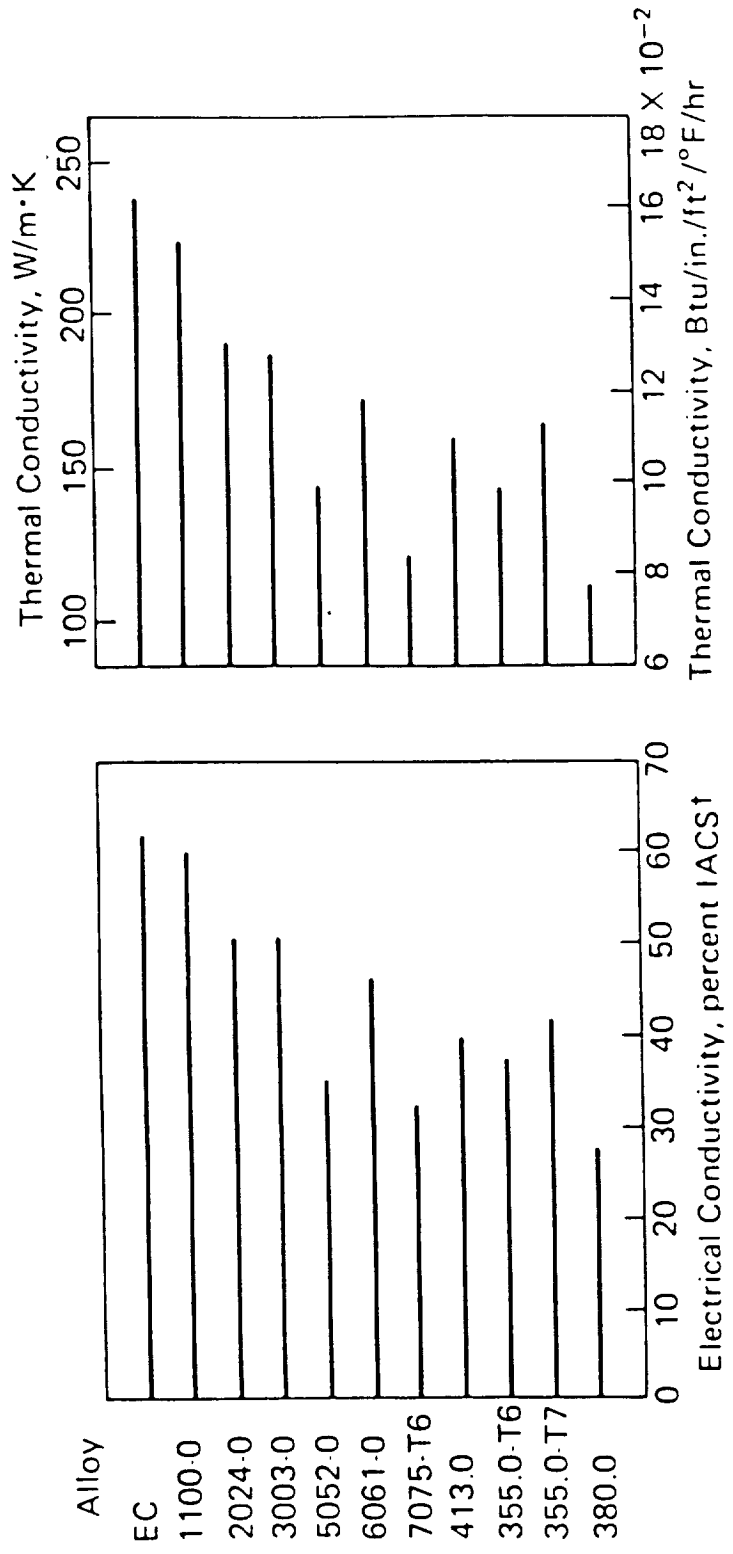

†International annealed copper standard

Electrical and thermal properties of aluminum alloys.

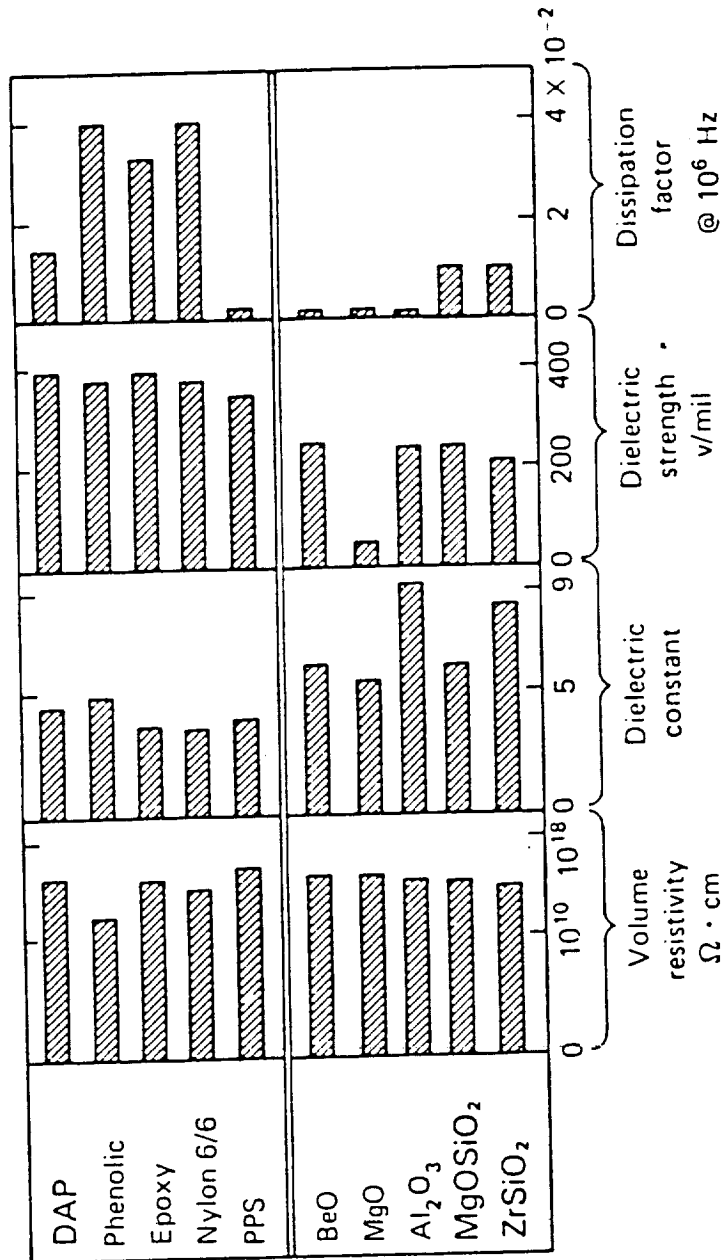

Comparison of the electrical properties of ceramics and plastics

## Decision Matrix for Rack Systems

### Rack Group

Design	Weight	Ease of Access	Size	Transportability
1	3	3	5	6
2	4	2	4	1
3	1	4	2	3
4	5	5	3	4
5	6	1	6	5
6	2	6	1	2

	Total
1 Radial Horizontal	17
2 Mounted on Skitter	11
3 Upright Self Supporting	10
4 Upright Supported by Foot Plate	17
5 Conical on Skitter	18
6 Rack on Dump Cart	11

LTM

Weight Analysis

Since weight is the primary consideration in determining the costs for this project, we neglected the material costs and focused on the weight of each component and related these weights to costs by assuming \$100,000.00 per pound for space travel. The weight of each component was calculated by finding the area for each part, then multiplying this area by a pound per square foot figure. These pound per square foot figure's were obtained from the Ryerson & Son Inc. Stocklist and Data book (1985-86) edition.

Note: All dimensions listed are in milli-meters.

<u>Qty</u>	<u>Part</u>	<u>Material</u>	<u>lb/ft</u>	<u>Weight</u>
2	160*38*5 Plate	Al 2219-T37	3.75	0.48lbs
2	110*38*5 Plate	Al 2219-T37	3.75	0.37lbs
1	110*62*5 Plate	Al 2219-T37	3.75	0.27lbs
1	110*37*5 Plate	Al 2219-T37	3.75	0.16lbs
2	254mm. Dia Plate	Al 2219-T37	3.75	1.21lbs
1	254*153*5 Cyl.	Al 2219-T37	3.75	1.95lbs
1	82*78*25 Block	Al 2219-T37	14.42	0.98lbs
1	25*25*5 Plate	AL 2219-T37	3.75	0.26lbs
1	180*20 Round	Al 2219-T37	3.75	0.49lbs
2	70*10 Round	Al 2219-T37	3.75	0.49lbs

1	142mm. Sq. Tube	Al 2219-T37	0.77	0.351bs
2	80*28 Cyl.	Al 2219-T37	1.46	0.121bs
2	180*9mm. Cyl.	Steel #A242	2.66	<u>.931bs</u>

Total Weight..... 9.161bs

Therefore, the cost for the transportation of the LTM by  
itself is 9.161bs. x \$100,000 \$/lb = \$916,000.00

LTM

Parts List (all dimensions in milli-meters)

1. Frame:

- (2) 160 x 38 x 5 Aluminum Plates
- (2) 110 x 38 x 5 Aluminum Plates

2. Mount:

- (1) 62 x 110 x 5 Aluminum Plate
- (1) 110 x 37 x 5 Aluminum Plate

3. Housing:

- (2) 254 mm. Diameter 5mm thick Aluminum Plate
- (1) 153 mm. Long 5mm thick Aluminum Cylinder

4. Slider:

- (1) 78 x 82 x 25 Aluminum Block

5. Plate:

- (1) 25 x 25 x 5 Aluminum Plate

6. Power Screw

- (1) 180 x 18 ## thread per inch screw

7. Bearings

- (2) 28mm. O.D. sealed caged ball bearings

8. Gears

- (2) 70mm. O.D., 10mm. face width Aluminum sealed, caged, ball bearings

9. Forks

- 500mm. of 16mm. square tubing (aluminum)

# WEIGHT CALCULATIONS

- 1. Frame (2) 160 mm x 38 mm x 5 mm Al Plate
- (2) 110 mm x 38 mm x 5 mm Al Plate

NOTE: CONVERT TO INCHES BECAUSE WEIGHT FACTORS ARE GIVEN IN lb/ft<sup>2</sup>

$$\frac{160}{25.4} = 6.3''$$

$$\frac{38\text{mm}}{25.4} = 1.49''$$

NOTE: FROM RYERSON & SON INC. DATA BOOK FOR AL 2219-T37 5mm thick plates;

(WEIGHT FACTOR)  $\frac{\text{WEIGHT}}{\text{Sq. FOOT}} = 3.75 \text{ lb/ft}^2$

∴ FOR FRAME

(# of Plates) →  $2 \times \left[ \frac{6.3\text{IN} \times 1.49\text{IN}}{144 \frac{\text{IN}}{\text{ft}^2}} \right] \times 3.75 \frac{\text{lb}}{\text{ft}^2} = .48 \text{ lbs}$

(# of Plates) →  $2 \times \left[ \frac{4.3\text{IN} \times 1.49\text{IN}}{144 \frac{\text{IN}}{\text{ft}^2}} \right] \times 3.75 \frac{\text{lb}}{\text{ft}^2} = .35 \text{ lbs}$

∴ TOTAL WEIGHT OF FRAME = .815 lbs

## 2. MOUNT :

- (1) 62mm x 110mm x 5mm Al Plate
- (1) 110mm x 37mm x 5 Al Plate

12 SHEETS 5 SQUARE  
 24 SHEETS 3 SQUARE  
 42 SHEETS 2 SQUARE  
 84 SHEETS 1 SQUARE  
 NATIONAL



# WEIGHT ANALYSIS

## FRAME (CONT)

$$1 \times \left[ \frac{2.44 \text{ IN} \times 4.33 \text{ IN}}{144 \text{ IN}^2/\text{ft}^2} \right] \times 3.75 \text{ lb}/\text{ft}^2 = .27 \text{ lbs}$$

$$1 \times \left[ \frac{4.26 \text{ IN} \times 1.49 \text{ IN}}{144 \text{ IN}^2/\text{ft}^2} \right] \times 3.75 \text{ lb}/\text{ft}^2 = .16 \text{ lb}$$

Therefore, Total  
WEIGHT of MOUNT = .43 lbs

## 3. HOUSING

(2) 254mm DIA. 5mm thick Al Plates

(1) 254mm DIA. x 153mm LONG Al Cyl (5mm)

$$\begin{aligned} \text{Surface Area Cylinder} &= \frac{\pi d}{4} \times L \\ &= \frac{\pi}{4} \left( \frac{254 \text{ mm}}{25.4 \text{ mm/in}} \right) \left( \frac{153 \text{ mm}}{25.4 \text{ mm/in}} \right) \left( \frac{1 \text{ ft}^2}{144 \text{ in}^2} \right) = .32 \text{ ft}^2 \end{aligned}$$

$$\text{Area Disk} = \frac{\pi}{4} \left( \frac{254}{25.4} \right) \left( \frac{1}{144} \right) = .26 \text{ ft}^2 \text{ (PER DISK)}$$

$$\therefore \text{WEIGHT CYL} = .32 \text{ ft}^2 \times 3.75 \text{ lb}/\text{ft}^2 = 1.2 \text{ lbs}$$

$$\text{WEIGHT 2 DISKS} = 2 (.26 \text{ ft}^2) \times 3.75 \text{ lb}/\text{ft}^2 = 1.95 \text{ lbs}$$

$\therefore$  TOTAL  
HOUSING = 3.2 lbs  
WEIGHT

# WEIGHT CALC'S

4. SLIDER : (1) 78mm x 82mm x 25mm Al BLOCK

NOTE : For 25mm thick Al Blocks, W.F. = 14.4 lb/ft<sup>2</sup>

$$\left( \frac{3.02 \times 322}{144} \right) \times 14.4 \text{ lb/ft}^2 = \underline{\underline{.97 \text{ lbs}}}$$

5. Power Screw : 2011-T5 Aluminum Rounds

W.F. = .54 lbs/ft<sup>2</sup>

(1) 180mm x 20mm 18 thread/in SCREW

$$\frac{\pi}{4} \left( \frac{180}{25.4} \right) \left( \frac{20}{25.4} \right) \times \frac{1}{144} = .03 \text{ ft}^2$$

$$.03 \text{ ft}^2 \times .54 \text{ lbs/ft}^2 = \underline{\underline{.016 \text{ lbs}}}$$

6. PLATE : (1) 25mm x 25mm x 5mm Al Plate

$$\left( \frac{25.4}{25.4} \times \frac{25}{25.4} \right) \times \frac{1}{144} \times 3.75 \text{ lb/ft}^2 = \underline{\underline{.026 \text{ lbs}}}$$

7. BEARINGS : (2) 25mm O.D. sealed, caged, bearings

3 oz/each

DATA PRODUCTS  
BOOK

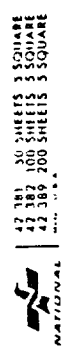



# WEIGHT CALC'S

11. Rods : (2) 9mm. Diameter ASTM# A242  
Solid Steel, low Carbon, RODS

$$W.F. = 2.66 \text{ lb/ft}^2$$

$$2 \left[ \left( \frac{9}{25.4} \right) \times \frac{\pi}{4} \right] \times 2.66 \text{ lb/ft}^2 = \underline{1.93 \text{ lbs}}$$

TOTAL ROD WEIGHT	= 1.93 lbs
------------------	------------

Therefore the total weight is the sum of the L T M components

1	FRAME	0.815	lbs
2	MOUNT	0.430	lbs
3	HOUSING	3.200	lbs
4	SLIDER	0.970	lbs
5	PLATE	0.026	lbs
6	POWER SCREW	0.016	lbs
7	BEARINGS	0.375	lbs
8	GEARS	0.491	lbs
9	FORKS	0.695	lbs
10	FINGERS	0.210	lbs
11	RODS	1.931	lbs

$$\text{TOTAL L T M WEIGHT} = 9.159 \text{ lbs}$$

# BEARING ANALYSIS :

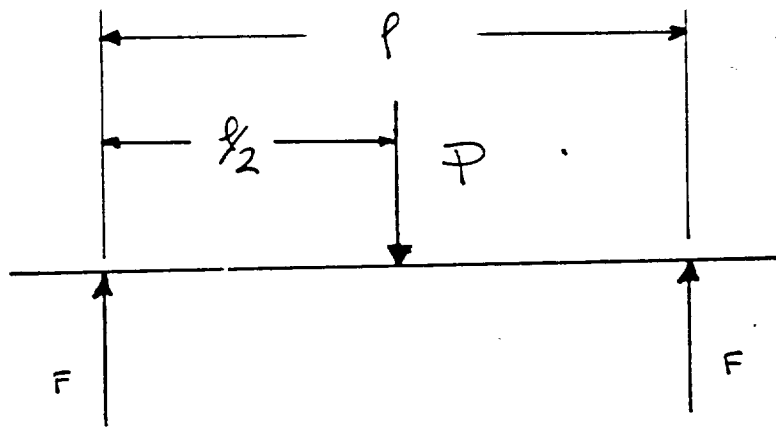
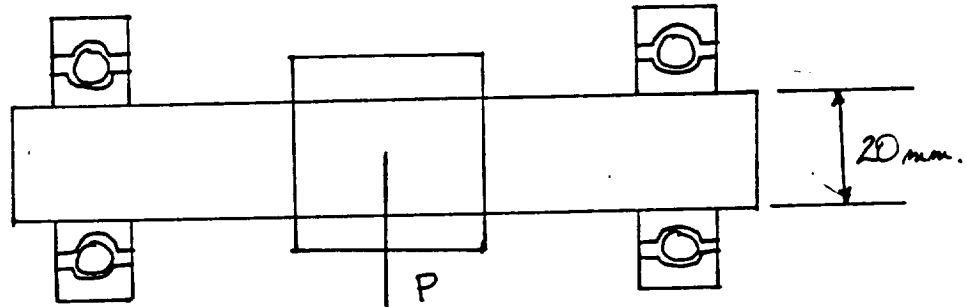

LOAD

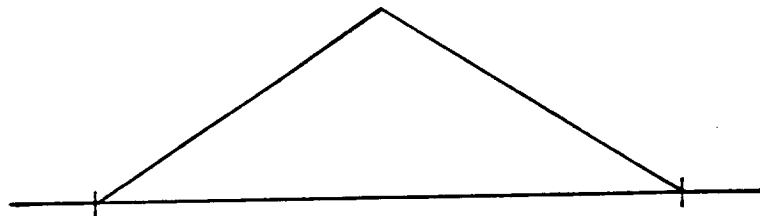

MOMENT

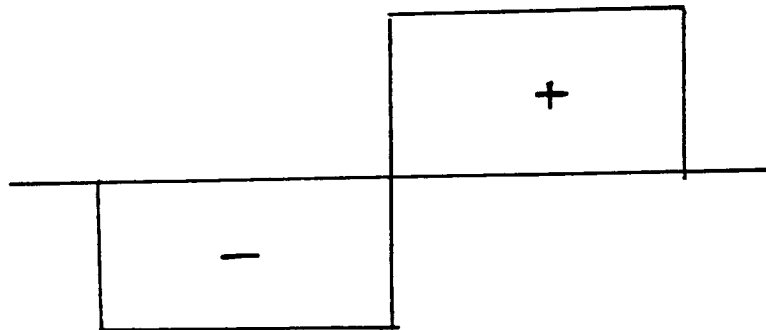

SHEAR FORCE

# BEARING ANALYSIS : (CON'T)

$$\Sigma M_o = 0 \quad P \cdot \frac{l}{2} = F_b \cdot l$$

$$F_b = P \frac{l}{2l}$$

$$\therefore F_b = \frac{P}{2}$$

TO CALCULATE THE MAX. LOAD TRANSMITTED TO THE BEARINGS, ASSUME THAT EACH 'FINGER' SUPPORTS 1/3 OF THE TOTAL LOAD. THE THUMB SUPPORTS 1/3 OF THE TOTAL LOAD. THE MAX. (DESIGN) LIFTING LOAD WE USED IS 50 lbs. THEREFORE, THE LOAD CARRIED BY THE FINGERS IS

$$\frac{2}{3} \times 50 \text{ lbs} = 33.3 \text{ lbs}$$

$$F_b = 148.7 \text{ N} \times 2$$

$$\text{SO } F_b = 74.3 \text{ N (PER BEARING)}$$

TO DETERMINE BEARING'S MATERIAL SELECTION, EXAMINE THE PV RATING. WHERE:

$$P = \frac{F_b}{l \cdot d} \quad (lb/in^2) \quad V = \frac{\pi D N}{12} \quad (ft/min)$$

↑ BEARING LENGTH
↑ BEARING DIA.
↑ BEARING LOAD

$$\text{THEREFORE, } PV = \frac{\pi F N}{12l} = \frac{.262 \text{ N}}{l}$$

42 381 30 SHEETS 3 SQUARE  
42 382 100 SHEETS 3 SQUARE  
42 389 200 SHEETS 3 SQUARE  
NATIONAL

# BEARING ANALYSIS : (CON'T)

IN ORDER TO ENSURE THAT THE BEARINGS WILL NOT FAIL AT FULL SPEED, THE PV VALUE IS DETERMINED FOR EACH SPECIFIC MATERIAL. THE PV FIGURE IS A DETERMINATION OF THE HEAT GENERATION IN THE BEARING TO TO FRICTION

REFERENCE : PV DATA OBTAINED FROM

STOCK DRIVE PRODUCTS INC.

55 SOUTH DALTON AVE

NEW HYDE PARK, N.Y. 11040

DATA BOOK # 757 p 635

MATERIAL	P <sub>STATIC</sub> (PSI)	P <sub>DYN.</sub> (PSI)	V (fpm)	PV
BRONZE	8,000	2,000	1,200	50,000
COPPER-IRON	20,000	4,000	1,500	35,000
(HARDENED) LEAD - BRONZE	60,000	800	3,500	60,000
IRON	10,000	3,000	400	30,000
BRONZE-IRON	10,500	2,500	800	35,000
LEAD-IRON	4,000	1,000	800	50,000
ALUMINUM	4,000	2,000	1,200	50,000

TO DETERMINE IF AN ALUMINUM BEARING WILL SURVIVE IN OUR APPLICATION, WE CALCULATE THE PV VALUE FOR THE DESIGN ENVIRONMENT AND MAKE SURE IT IS BELOW THE PUBLISHED PV VALUES FOR ALUMINUM

12 SHEETS 3 SQUARE  
 24 SHEETS 3 SQUARE  
 36 SHEETS 3 SQUARE  
 48 SHEETS 3 SQUARE  
 NATIONAL

## BEARING ANALYSIS : (CON'T)

$$PV_{\text{DESIGN}} = \frac{\pi FN}{12 \phi}$$

$$= \frac{.262 FN}{\phi}$$

$$= \frac{(0.262)(74.3 \text{ N})(10 \text{ ROT/S})(60 \text{ } \frac{\text{S}}{\text{MIN}}) \left( \frac{1 \text{ lb}}{4.44 \text{ N}} \right)}{(6 \text{ mm}) \left( \frac{1 \text{ IN}}{25.4 \text{ mm}} \right)}$$

$$\underline{\underline{PV_{\text{DESIGN}} = 11,386 \left( \frac{\text{lb}}{\text{in} \cdot \text{min}} \right)}}$$

$$PV_{\text{MAX FOR AL}} = 50,000 \left( \frac{\text{lb}}{\text{in} \cdot \text{min}} \right)$$

$$\therefore \text{FACTOR OF SAFETY} = \frac{50,000}{11,386} = \underline{\underline{4.39}}$$



Gripper functions: The coefficient of friction of the fingers on the rod (aluminum on aluminum) is approximately one(1) because of the lack of atmosphere and the fact that the surfaces are not clean (Ashby and Jones).

Because of the fact that  $\mu = 1.0$ , any gripping force provided provides an ability to lift the same load ( $F = \mu N$ ).

The power screw turns at 10 RPM. The pitch of the screw is 1.5mm (1.5mm travel/revolution).

$$(10 \text{ RPM}) \times (1.5\text{mm}/\text{rev}) = 15\text{mm}/\text{s}$$

For a 70 mm travel of the fingers, a cycle time

$$(1/2 \text{ cycle}) = (70\text{mm})/(15\text{mm}/\text{s}) = 4.7 \text{ seconds}$$

$$\text{Torque (needed)} = (F \times \text{dm})/2$$

The maximum load to be picked up = 26.5 N  
(auger filled with dirt)

An impulse from jerky movement would multiply the load by 10.  
Thus,

$$F (\text{needed}) = 10 \times (26.5 \text{ N}) = 265 \text{ N}$$

$$\text{Torque (needed)} = (265 \text{ N}) \times (19\text{mm}) = 2.52 \text{ Nm}$$

$$\text{Lifting capacity} = 265 \text{ N} \quad (F = \mu N)$$

The geometry of the thumb and fingers is shown in Appendix B.2

K.W.

## MASS ANALYSIS - TUBE SENSORS

$$\rho_{Al} = 2900 \text{ kg/m}^3$$

$$\rho_{ceramic} = 3980 \text{ kg/m}^3$$

### TUBE BODY & FLANGE

$$V_{TUBE} = \frac{\pi}{4} (1.022^2 - 1.014^2) \times 1.276 \text{ m}$$

$$V_{TUBE} = 6.243 \times 10^{-5} \text{ m}^3$$

$$V_{FLANGE} = \frac{\pi}{4} (1.038^2 - 1.022^2) \times 0.005 = 2.1206 \times 10^{-6} \text{ m}^3$$

$$V_{CUTOUT} \approx 1004 \times 0.012 \times 0.075 = 3.6 \times 10^{-6}$$

$$V_{TOTAL} = V_{TUBE} + V_{FL} - V_{CO} = 6.095 \times 10^{-5} \text{ m}^3$$

$$M = V \times \rho = (6.095 \times 10^{-5} \text{ m}^3) (2900 \text{ kg/m}^3) = \boxed{0.177 \text{ kg}}$$

### HOOK - BOTTOM PIECE

$$V = \frac{\pi}{4} (1.022)^2 \times 1.045 - \frac{\pi}{4} (1.022)^2 \times 1.007$$

$$V = 1.4445 \times 10^{-5} \text{ m}^3$$

$$M = (1.4445 \times 10^{-5} \text{ m}^3) (2900 \text{ kg/m}^3) = \boxed{0.0419 \text{ kg}}$$

### SENSOR INSERT

$$V = \left[ \pi (1.0065^2 - 1.0035^2) + (1.0045 \times 1.011) \right] \times 1.075$$

$$V = 1.0781 \times 10^{-5} \text{ m}^3$$

$$M = (1.0781 \times 10^{-5} \text{ m}^3) (3980 \text{ kg/m}^3) = \boxed{0.0429 \text{ kg}}$$

$$\begin{aligned} \text{TOTAL MASS} &= 0.177 \\ &0.0419 \\ &0.0429 \\ \hline &0.262 \text{ kg} \end{aligned}$$

$$0.262 \text{ kg} = \boxed{262 \text{ g}}$$

$$= 0.577 \text{ lb}_m \rightarrow \text{earth}$$

$$= 0.1 \text{ lb}_m \rightarrow \text{MOON}$$

(THE MASS IS ALMOST NEGLIGABLE)

# STRESS ANALYSIS ON THUMB

(SKITTER WILL ALWAYS "SQUAT" TO PICK UP)  
 RACK, THE FORCES ON THE THUMB WILL BENDING STRESS ON HOOK  
 ALWAYS BE AXIAL)

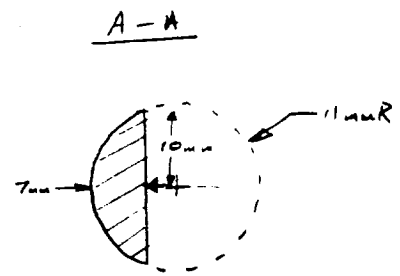
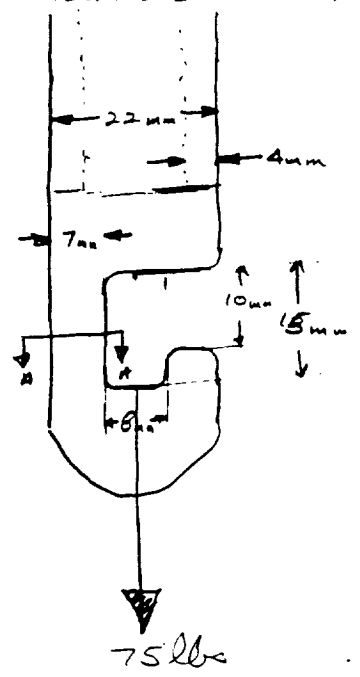

FOR THIS GEOMETRY:

$$A = 2 \left[ \frac{1}{2} (7)(10) + \frac{1}{2} (2)(2) \right]$$

$$A = 94 \text{ mm}^2$$

$$\alpha = 2 \cos^{-1} \frac{4}{11}$$

$$\alpha = 137.35^\circ$$

$$k = \frac{(1 - \cos 137.35^\circ) \sin 137.35^\circ}{\frac{137.35}{360} \cdot 2\pi - \sin 137.35^\circ}$$

$$k = 0.6837$$

$$I_x = \frac{AR^2}{12} (3 - k)$$

$$k = \frac{(1 - \cos \alpha) \sin \alpha}{\alpha - \sin \alpha}$$

## YIELD STRESS IN HOLLOW THUMB

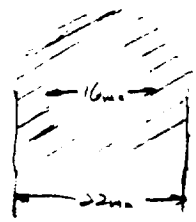

$$A = \frac{\pi}{4} (D_o^2 - D_i^2)$$

$$A = \frac{\pi}{4} ((22 \text{ mm})^2 - (16 \text{ mm})^2)$$

$$A = 179.07 \text{ mm}^2 \times \left( \frac{1 \text{ in}}{25.4 \text{ mm}} \right)^2$$

$$= 0.27756 \text{ in}^2$$

$$T = \frac{F}{A} = \frac{75 \text{ lb}}{0.27756 \text{ in}^2}$$

$$T = 270.3 \text{ psi}$$

$T < 0.6 S_y$  (FOR BUTT WELD INTERIOR)

$$S_y > \frac{T}{0.6} = \frac{270.3}{0.6} = 450.5 \text{ psi}$$

$$I_x = \frac{AR^2}{12} (3 - k)$$

$$I_x = \frac{(94 \text{ mm}^2)(11 \text{ mm})^2}{12} (3 - 0.6837)$$

$$I_x = 2195.47 \text{ mm}^4 \times \left( \frac{1 \text{ in}}{1000 \text{ mm}} \right)^4 \times \left( \frac{32 \text{ in}^4}{\text{mm}^4} \right)$$

$$= 100529 \text{ in}^4$$

$$T_{max} = \frac{Mc}{I}$$

$$T_{max} = \frac{(11 \text{ mm})(75 \text{ lb})(11 \text{ mm})}{2195.47 \text{ mm}^4}$$

$$T_{max} = 1.1335 \frac{\text{lb}}{\text{mm}^2} \times \left( \frac{25.4 \text{ mm}}{1 \text{ in}} \right)^2$$

$$T_{max} = 2667 \text{ psi}$$

IF  $S_y$  OF ALUMINUM IS AS LOW AS 8000 PSI?  
 (IT COULD BE 50000 PSI +)

WE NEED  $S_u$  of 106psi FOR FACTOR OF SAFETY of  $\frac{1}{10}$

42 181 50 SHEETS 5 SQUARE  
 42 182 100 SHEETS 5 SQUARE  
 42 183 200 SHEETS 5 SQUARE  
 42 184 300 SHEETS 5 SQUARE  
 42 185 400 SHEETS 5 SQUARE  
 42 186 500 SHEETS 5 SQUARE  
 42 187 600 SHEETS 5 SQUARE  
 42 188 700 SHEETS 5 SQUARE  
 42 189 800 SHEETS 5 SQUARE  
 42 190 900 SHEETS 5 SQUARE  
 42 191 1000 SHEETS 5 SQUARE

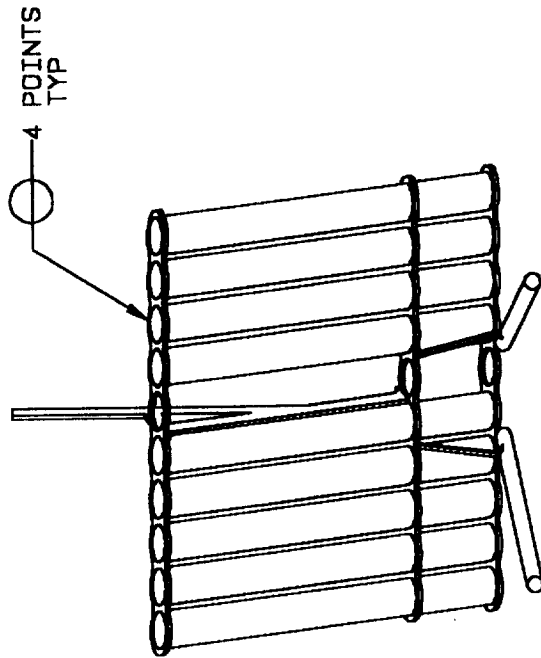
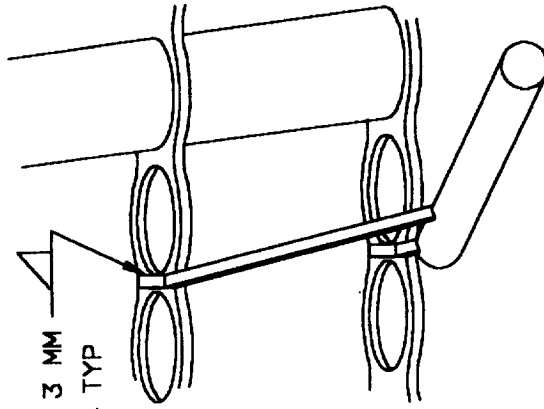
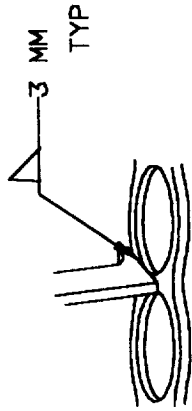
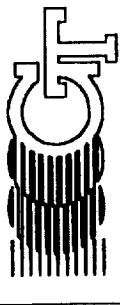

WELD SPECS

A permissible stress for welds:  
(AISC standards):  $\rightarrow \frac{S_y}{2}$

In shear:

$$\begin{aligned}\sigma_{allow} &= 0.4 S_y \\ &= 0.4(620.1 \times 10^6 \text{ Pa})\end{aligned}$$

$$\sigma_{allow} = 2.48 \times 10^8 \text{ Pa}$$

Factor of safety for this weld:

$$n = \frac{2.48 \times 10^8}{8.39 \times 10^7} = \boxed{2.96}$$

## Fork Stress Calculations

Max stress at top (F):

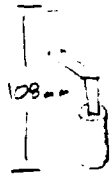

$$M_A = (265 \text{ N}) \times (.03 \text{ m}) = 23.62 \text{ N}\cdot\text{m}$$

Stress in case of bending:

$$\sigma = \frac{M c}{I} = \frac{(23.62 \text{ N}\cdot\text{m}) (.008 \text{ m})}{I}$$

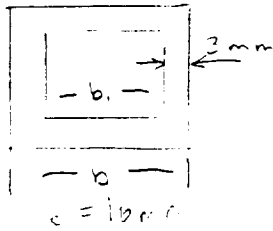

$$I = \frac{b^4}{12} - \frac{b_1^4}{12} = \frac{(.016)^4}{12} - \frac{(.010)^4}{12}$$

$$= 4.63 \times 10^{-9} \text{ m}^4$$

$$\therefore \sigma = 4.95 \times 10^7 \text{ N/m}^2$$

Stress in weld more difficult to measure:

$$I = \frac{d^2}{6} (3b + d) \rightarrow \text{Shigley, p. 429}$$

$$I = \frac{(.016)^2}{6} [3(.016) + .016] = 2.73 \times 10^{-6}$$

$$\frac{\sigma}{\text{act}} = \frac{M c}{I} = \frac{(23.62 \text{ N}\cdot\text{m}) (.008 \text{ m})}{(2.73 \times 10^{-6} \text{ m}^4)} = \boxed{8.39 \times 10^7 \text{ N/m}^2}$$

Weld is most critical.

Use electrode # E90xx,  $S_y = 620.1 \times 10^6 \text{ N/m}^2$

# Top Plate Bending

100 mm racks

$$C = 125 \text{ mm} = .125 \text{ m}$$

$$I = 8.05 \text{ E}^{-12}$$

$$P = .597 \text{ N}$$

$$r = .65 \text{ m}$$

$$\sigma = \frac{P r C}{I} = \frac{.597 \text{ N} (.65 \text{ m}) (.125 \text{ m})}{8.05 \text{ E}^{-12} \text{ m}^4} = \frac{.481 \text{ N} \cdot \text{m}^2}{8.05 \text{ E}^{-12} \text{ m}^4} = 5.924 \text{ E}^9 \frac{\text{N}}{\text{m}^2}$$

Stress Analysis in top plate.

$$\sigma = \frac{M C}{I} = \frac{P r C}{I}$$

50 mm racks

$$C = 50(1.25) = 62.5 \text{ mm} = 0.0625 \text{ m}$$

$I =$

Profile

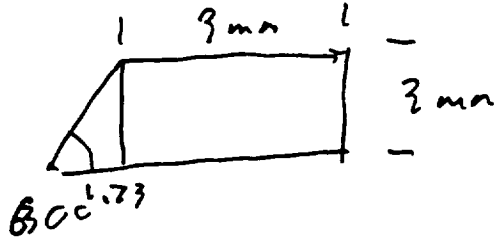

$$I_{\square} = bh^3/12 = 6.75 \text{ mm}^4$$

$$I_{\square} = bh^3/36 = 1.2979 \text{ mm}^4$$

$$\text{Total} = 8.047 \text{ mm}^4 \cdot \frac{\text{m}^4}{1 \text{E}^{12} \text{ mm}^4} = 8.047 \text{E}^{-12}$$

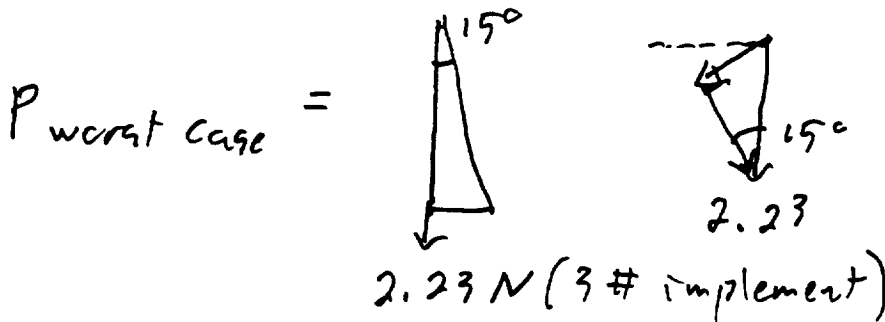

$$\frac{P}{2.23} = \sin 15^\circ$$

$$P = 0.5777 \text{ N}$$

$$r = 0.69 \text{ m}$$

$$\sigma = \frac{0.5777 \text{ N} \cdot 0.69 \text{ m} \cdot 0.0625}{8.047 \text{E}^{-12}}$$

$$\sigma = 2.91 \text{E}^9 \text{ N/m}^2$$



Hoop stress in tubes  
does not apply

Buckling and Bending in the tubes



worst Case

$$\tan^{-1} \frac{12.5 \text{ mm}}{1500 \text{ mm}}$$

at CG

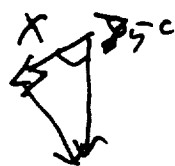

$$x = .587 \text{ N}$$

$$2.27 \text{ N} \quad P \cdot 1.5 = .587 (1)$$

$$P = .391$$

$$M = .391 (1.5) = .587 \text{ Nm}$$

$$c = (26 \text{ or } 101) 1.25$$

$$I = \frac{\pi}{64} (d_o^4 - d_i^4)$$

$$= \frac{1.097 \text{ E}^{14}}{740829} \frac{\pi}{64}$$

$$= 36365 \text{ mm}^4 \quad \frac{.0575 \text{ m}}{50 \text{ mm}} = 9.47 \text{ E}^9 \frac{\text{N}}{\text{m}^2}$$

$$w = \frac{M c}{I} = \frac{.587 \text{ Nm} \cdot .02875 \text{ m}}{3.6365 \text{ E}^{-8}} = 4.64 \text{ E}^9 \frac{\text{N}}{\text{m}^2}$$

# Bending In the Legs

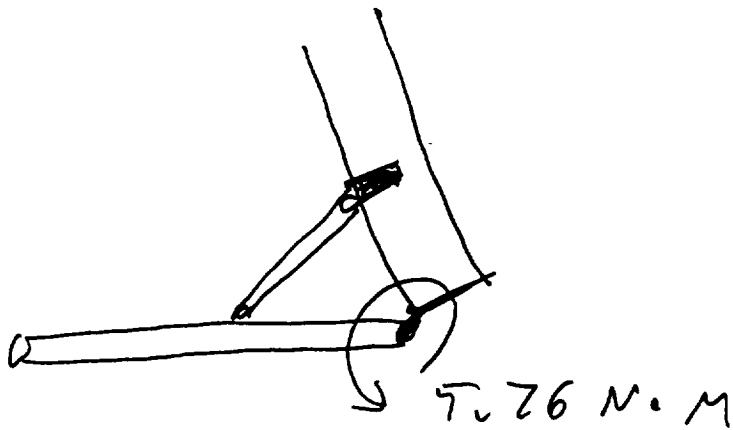

42 SHEETS 5 SQUARE  
42 SHEETS 100 SQUARE  
42 SHEETS 200 SQUARE



# Appendix B

## Drawings

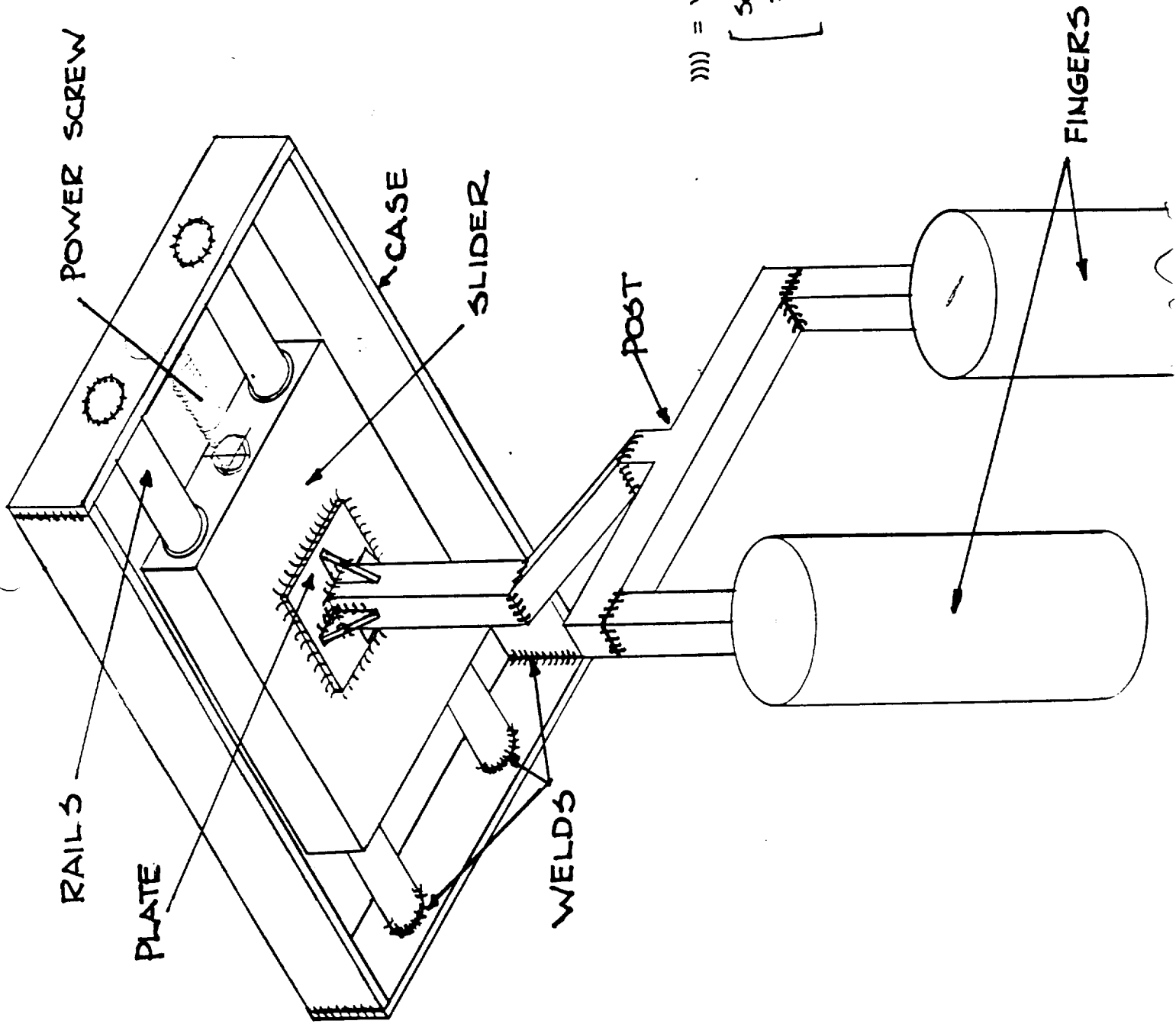

MARK BENSON  
2/24/89

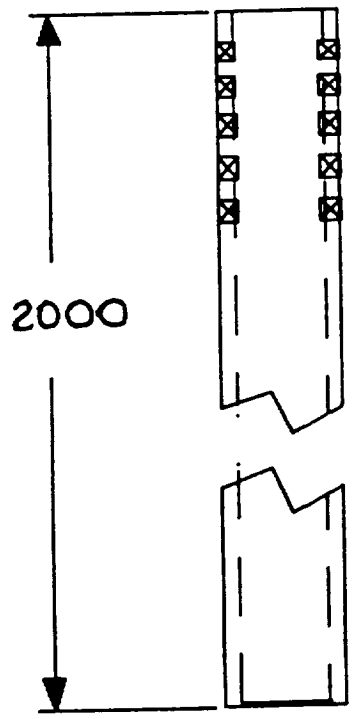
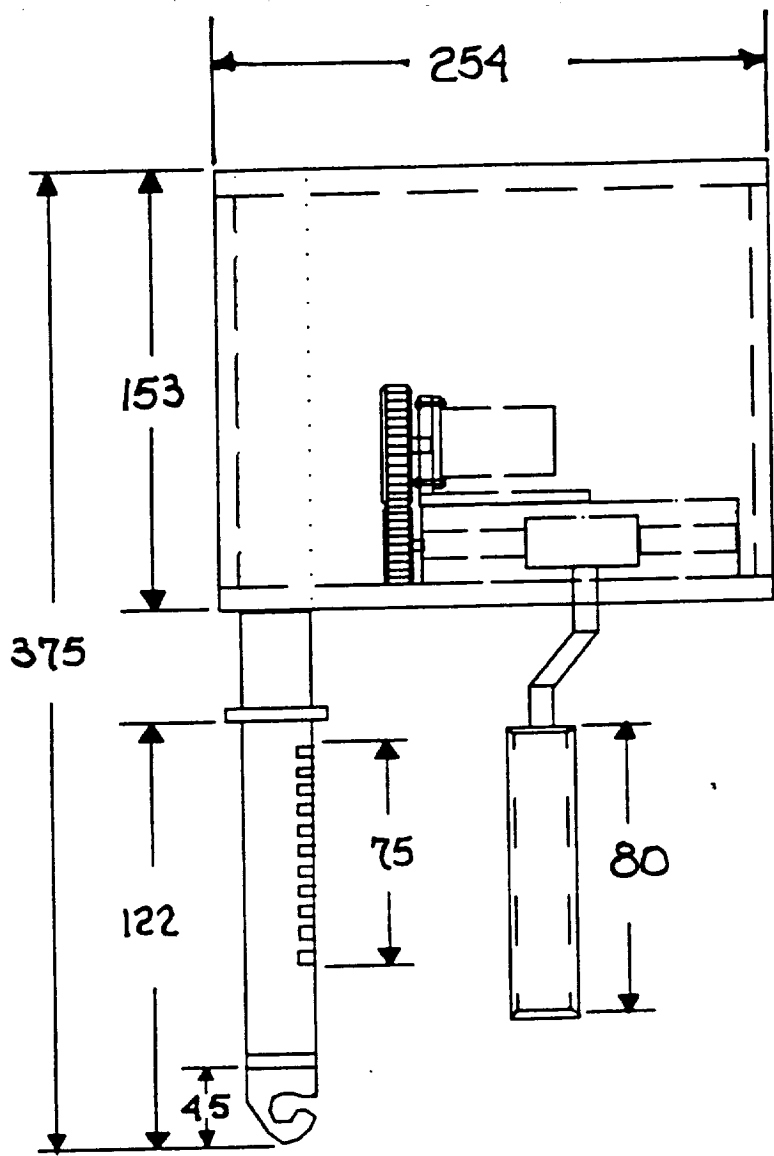

Gripper/Indexing  
Mechanism  
(profile View)

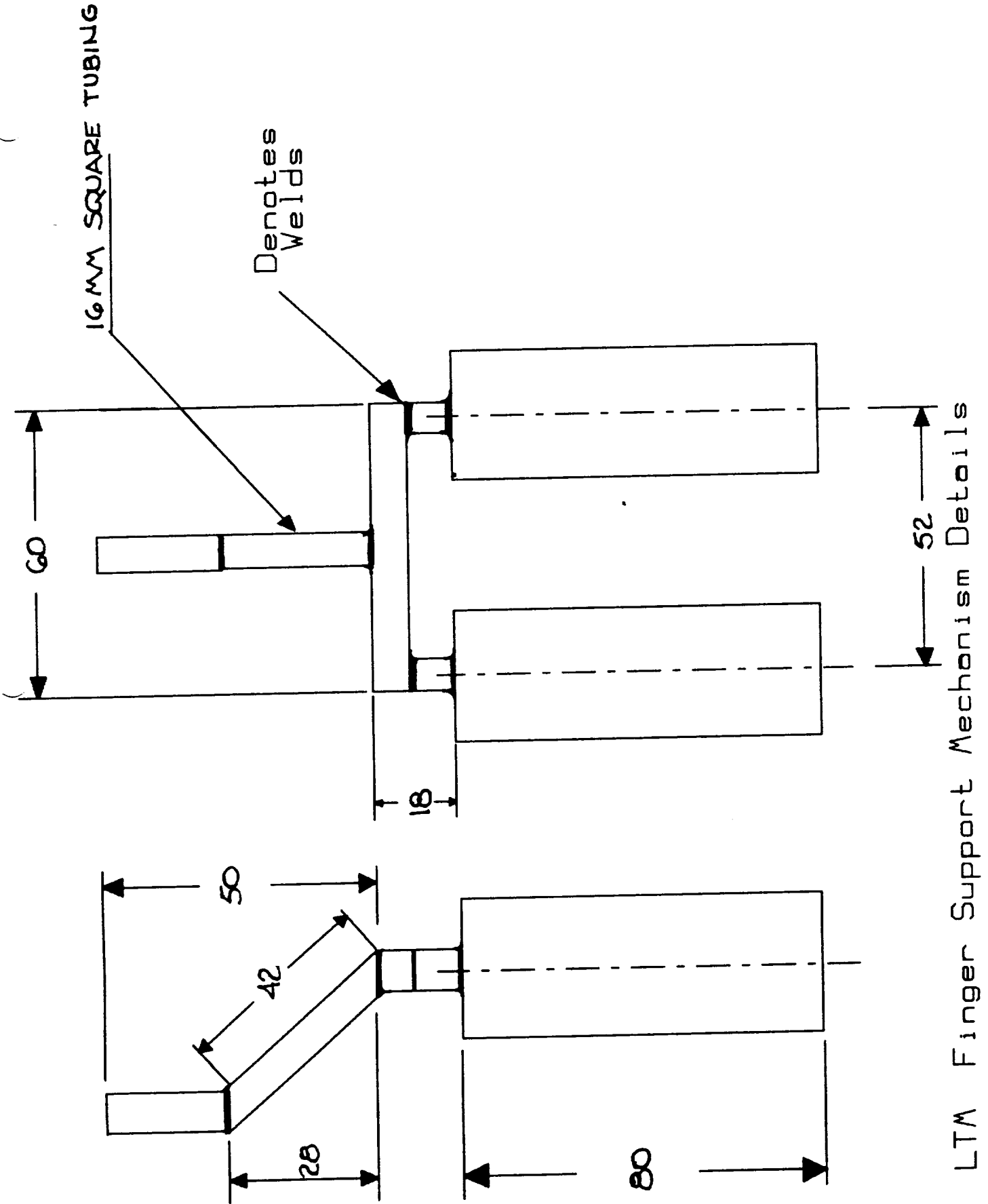

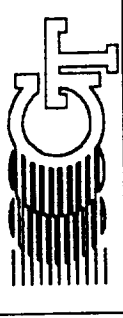

GEOMETRY OF GRIPPER

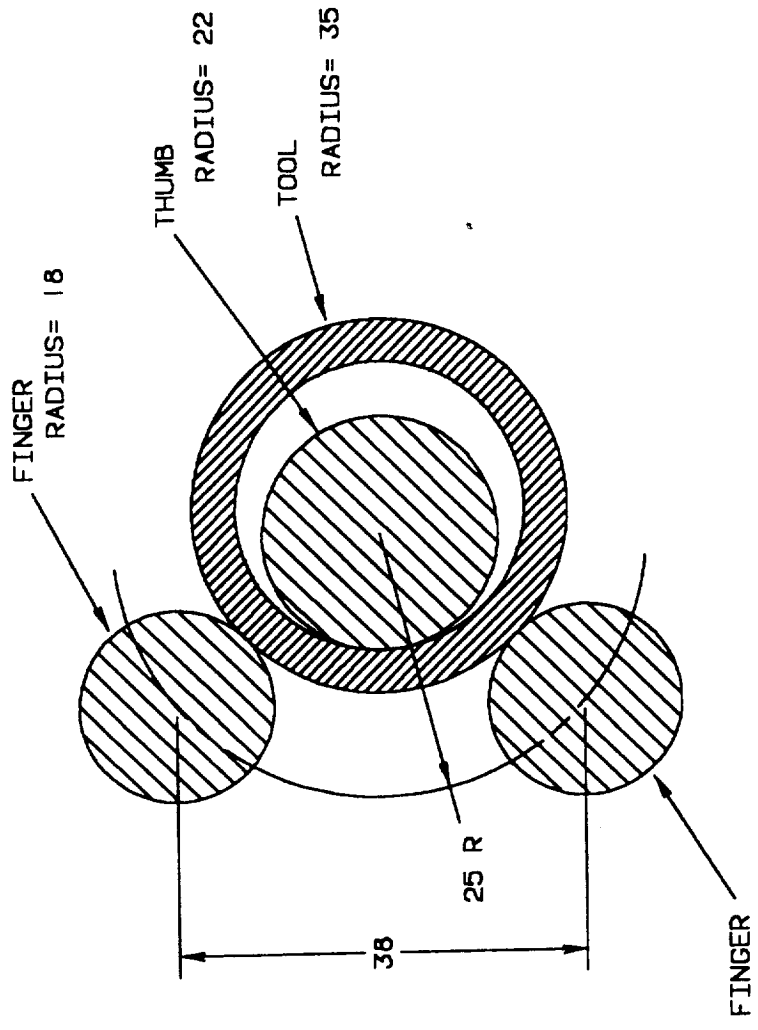

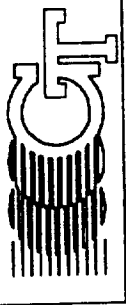

# LINEAR TRANSPORT MECHANISM

SIDE VIEW

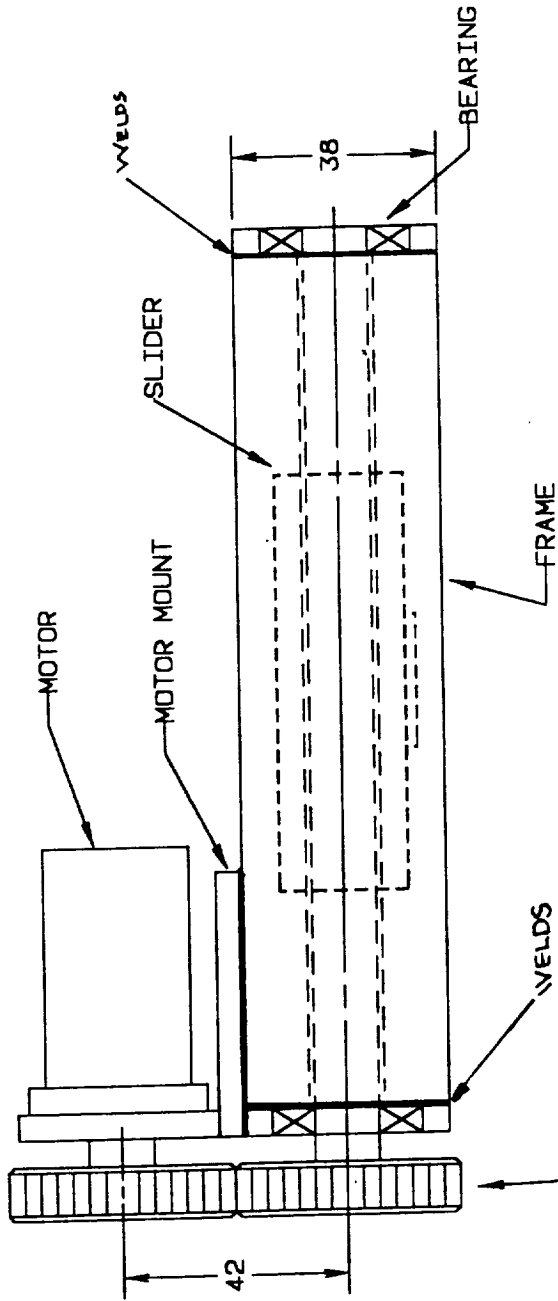

GEARS ARE BOTH 42 MM  
IN DIAMETER

DIMENSIONS IN MM



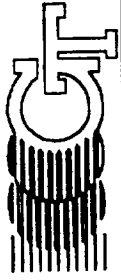

LINEAR TRANSPORT MECHANISM  
DETAILS

ALL DIMENSIONS IN MM

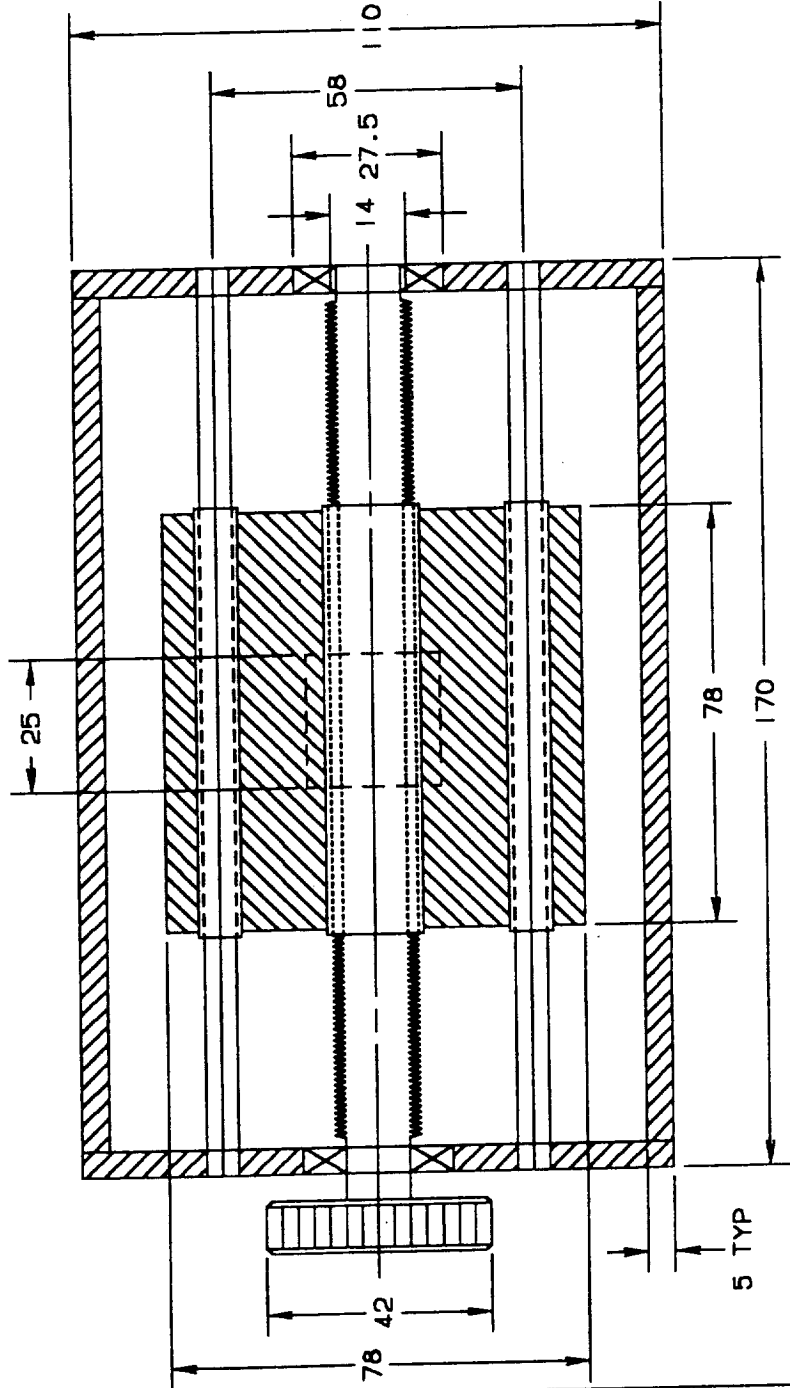

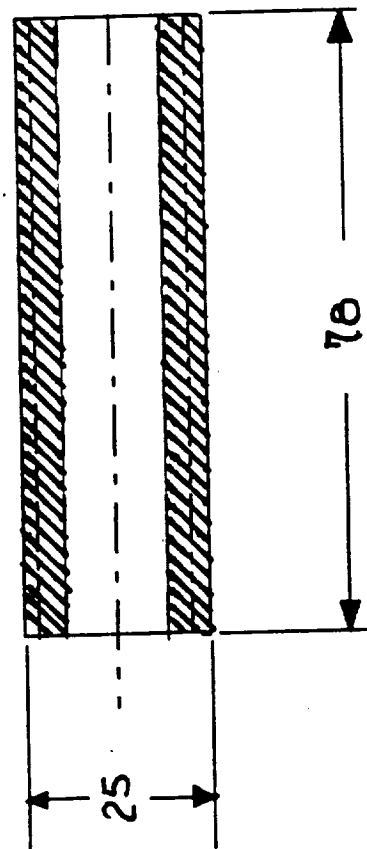
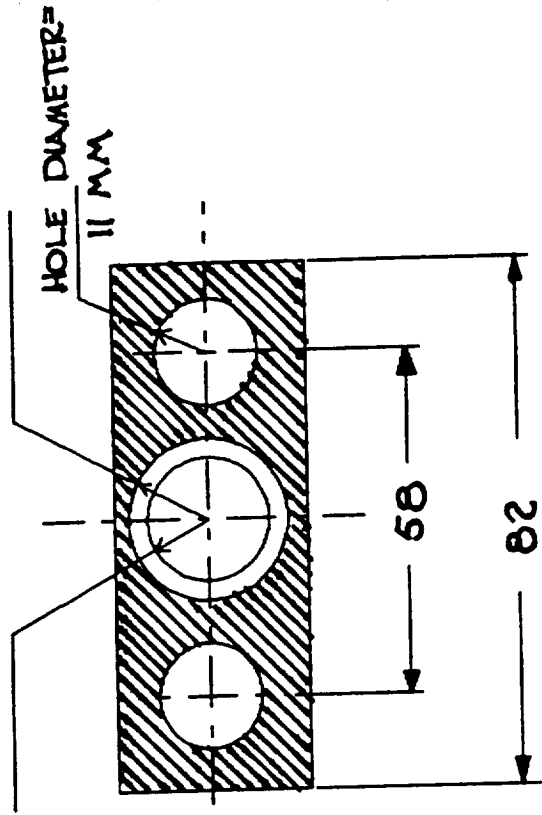
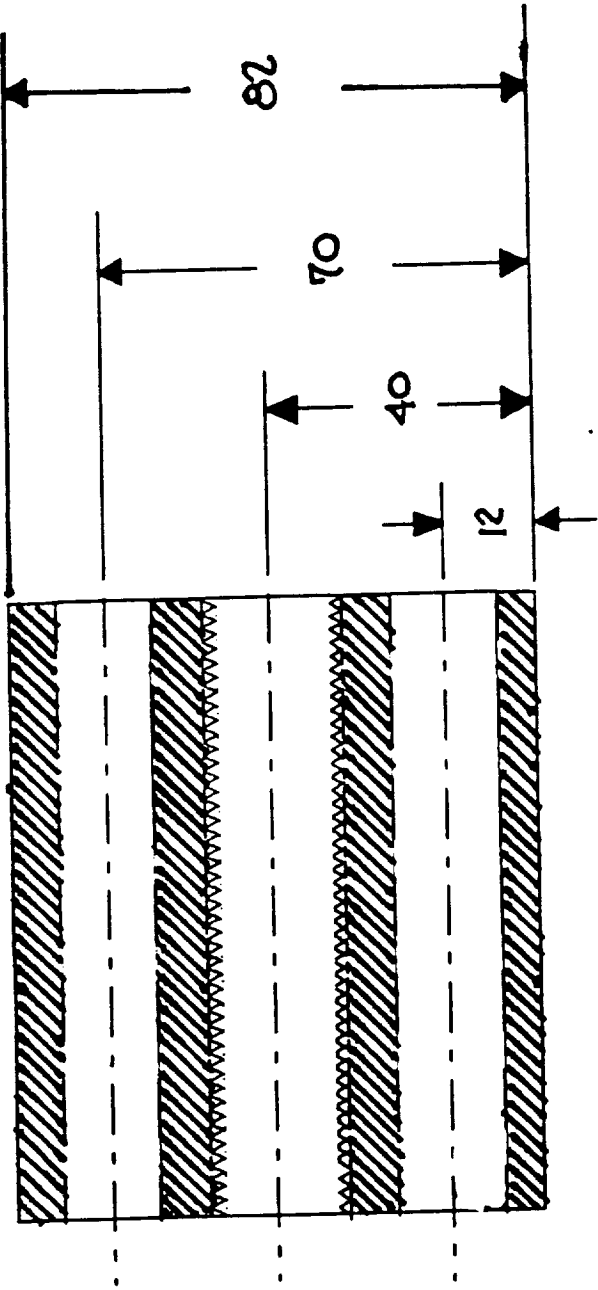

Slider Mechanism Details (LTM)

Stepping Motor Mount Details

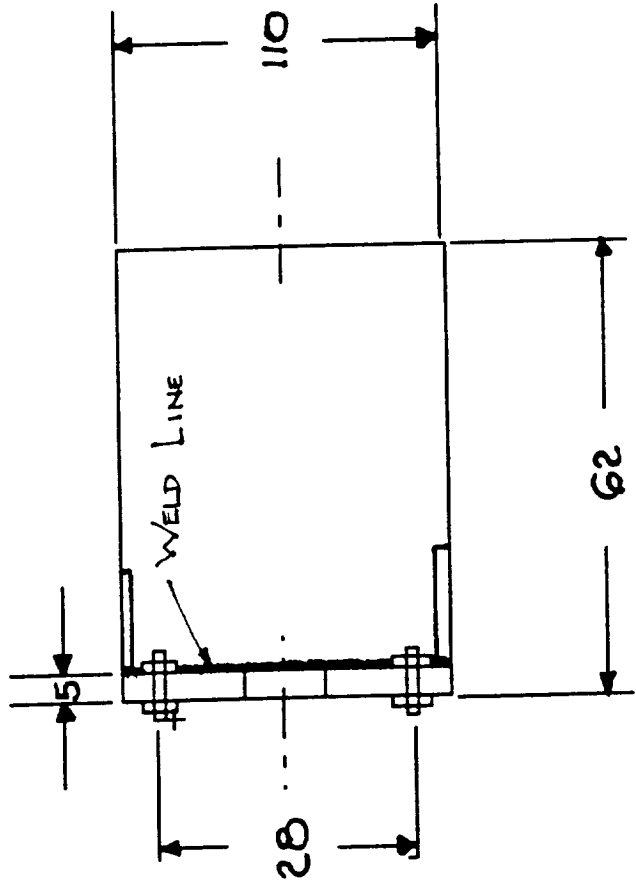
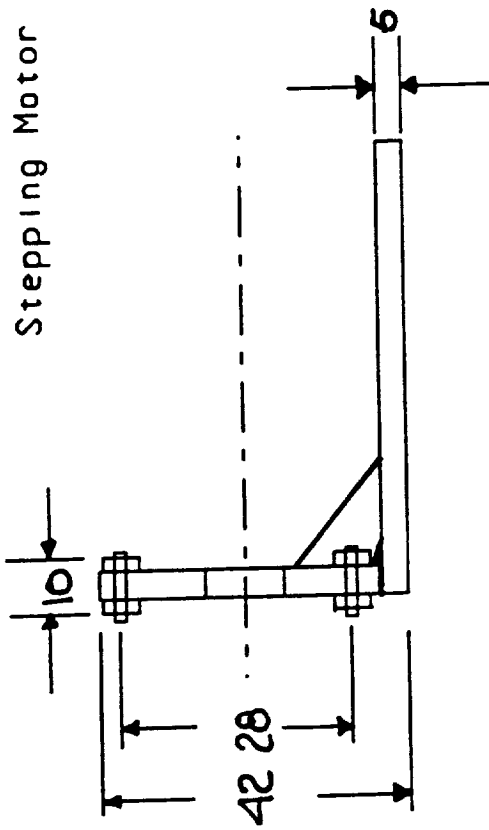

DRILL HOLE 35 MM  
DRILL HOLE 13 MM

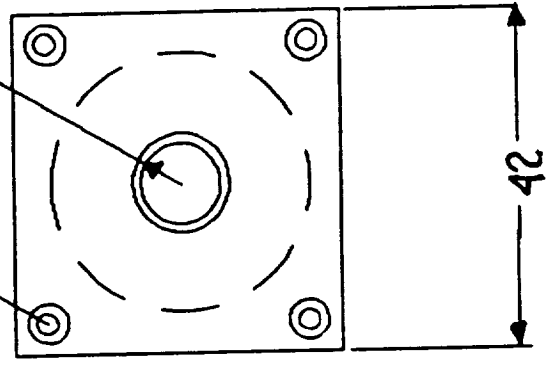

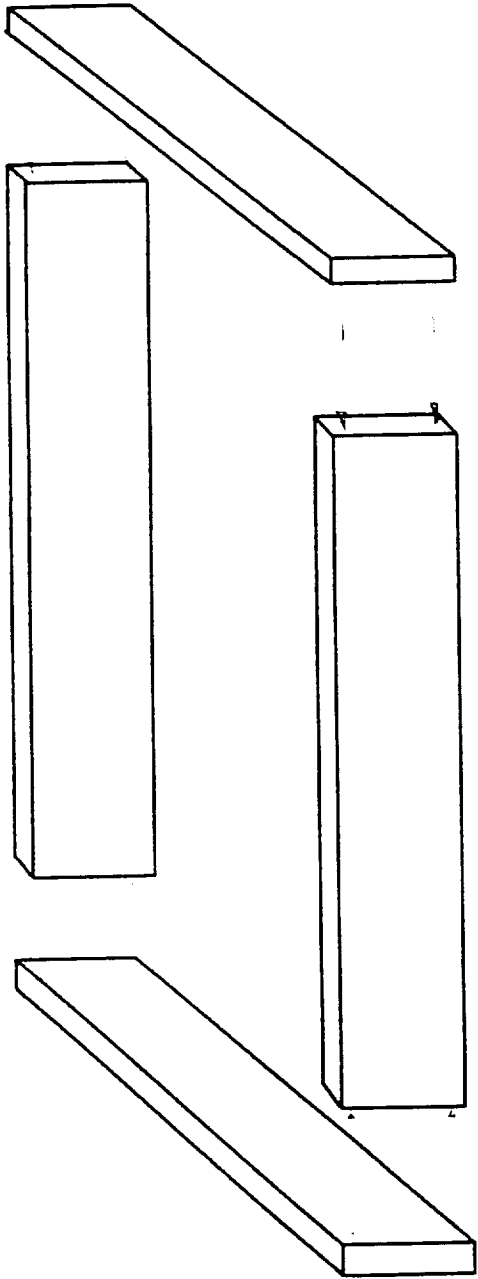

Frame Details

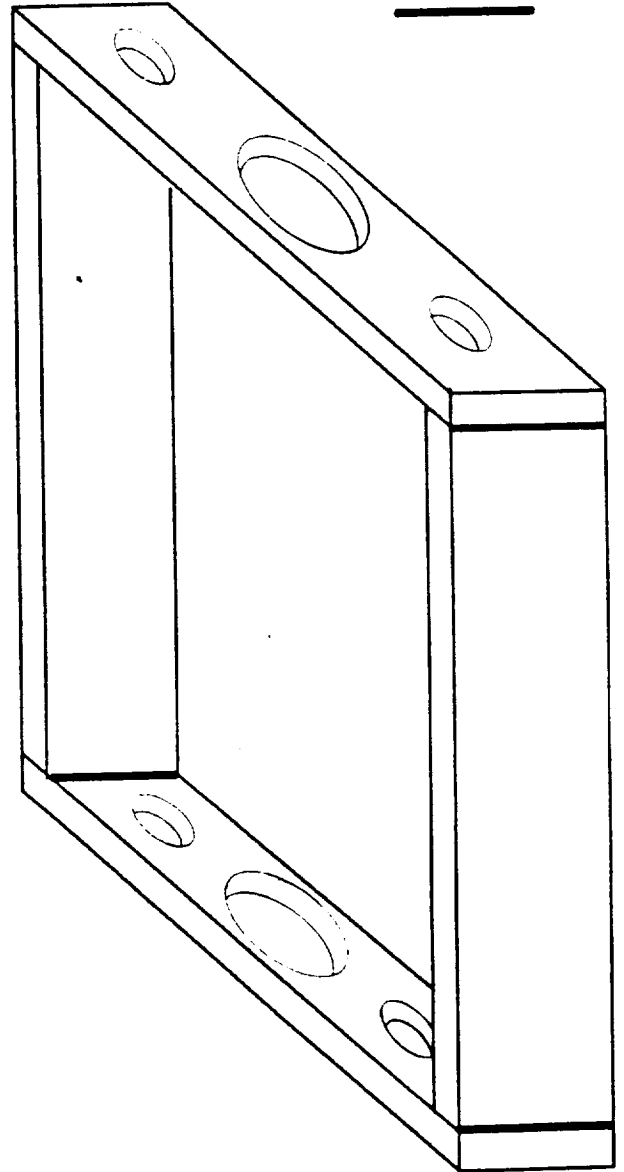

Denotes  
Weld

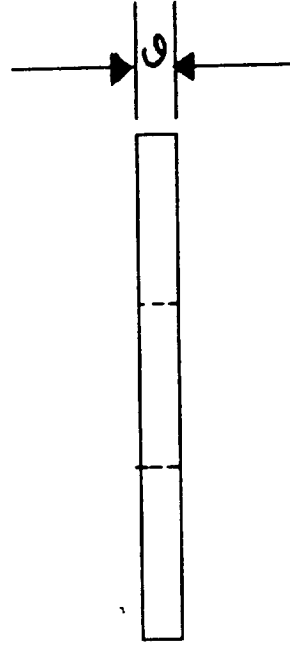
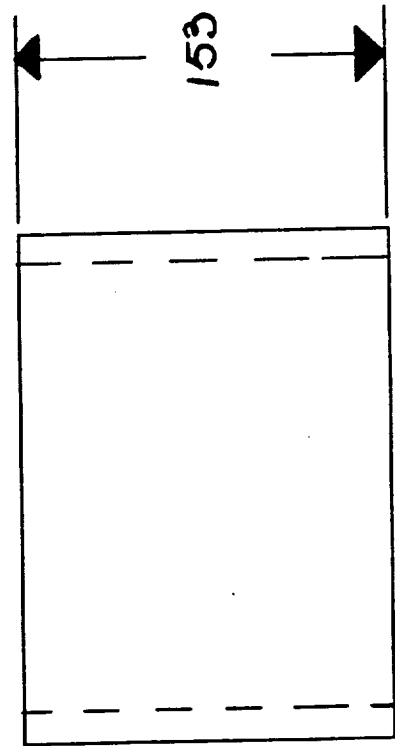
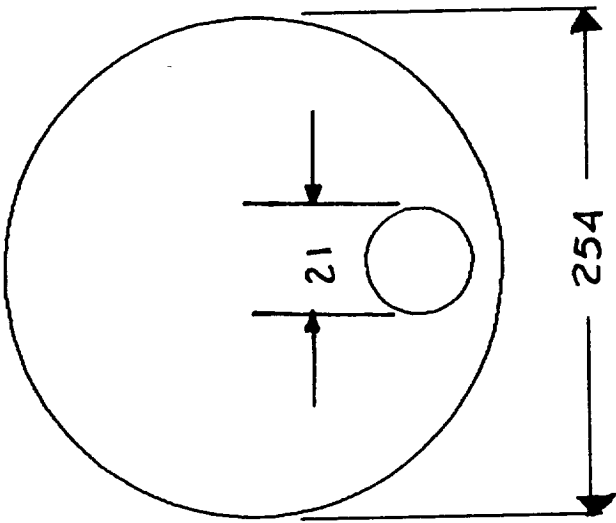
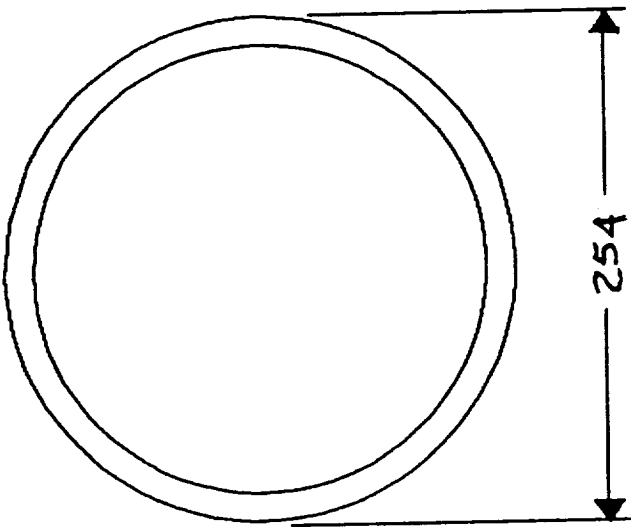

# Gripper/Housing Dimensions

# Mounting Plate for Arm (Finger support)

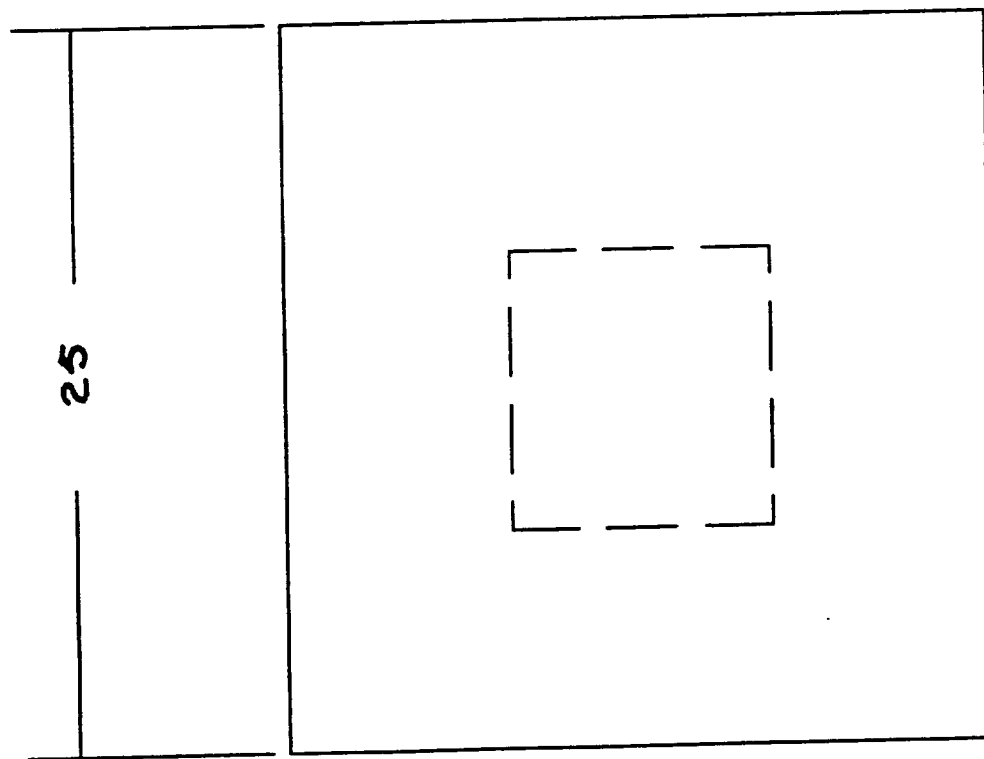

ALL DIMENSIONS IN MILLI-METERS

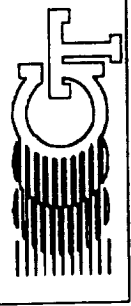

SENSOR INSERT

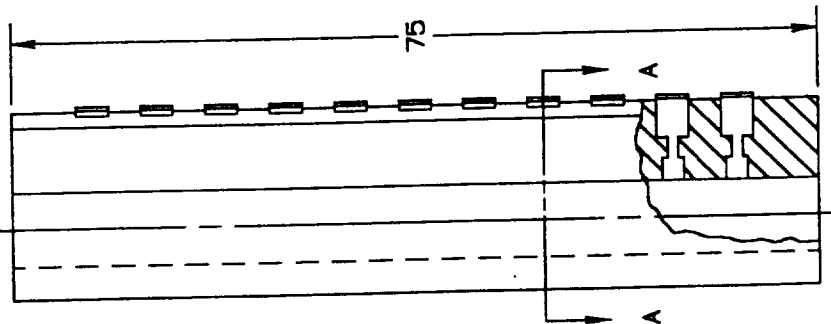
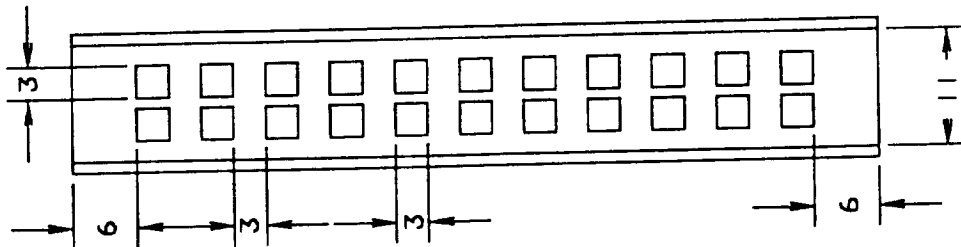

CONTACTORS (TYPICAL)

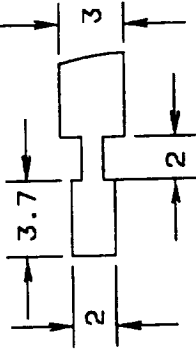

CONSTRUCTED FROM 3MM SQUARE BAR STOCK

SECTION A-A

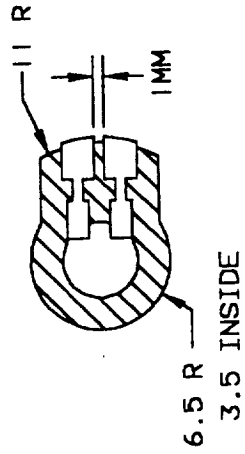

CONSTRUCTED FROM ALUMINA

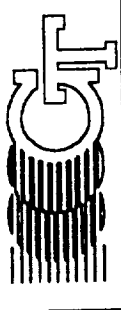

THUMB ASSEMBLY (3 PARTS)

- 1. TUBE BODY
- 2. SOLID HOOK
- 3. SENSOR INSERT

HOOK IS CONSTRUCTED OUT OF ALUMINUM STOCK AND WELDED TO TUBE

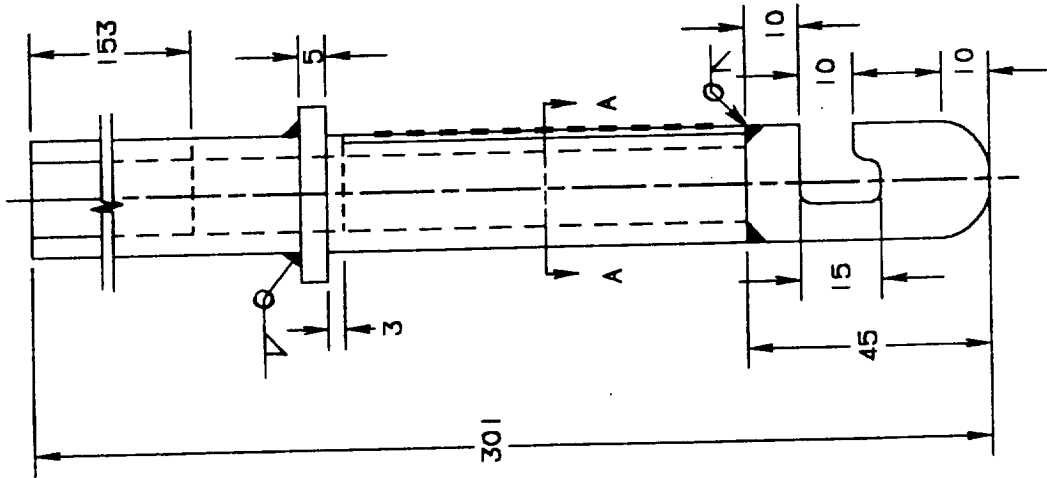

SECTION A-A

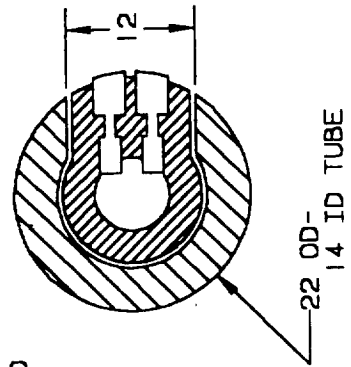

ALL UNSPECIFIED RADIUS 2.5





ROD WITH RINGS INSERTED

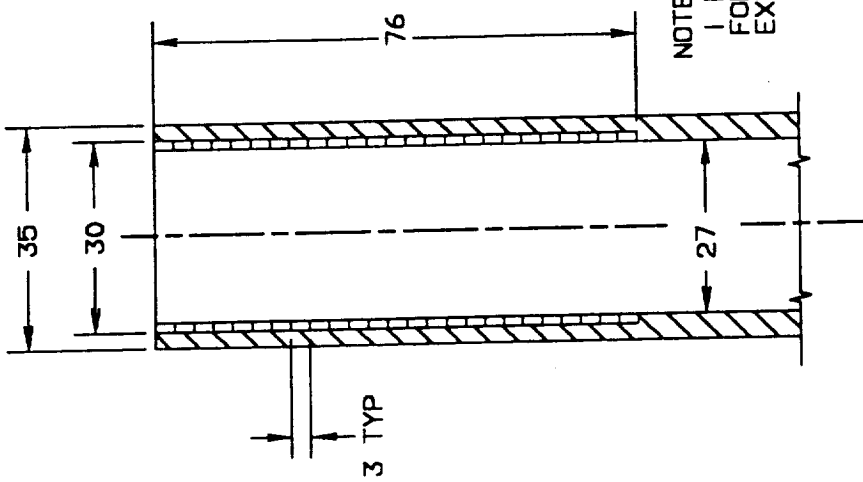

RINGS (TYPICAL)

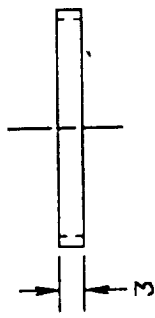
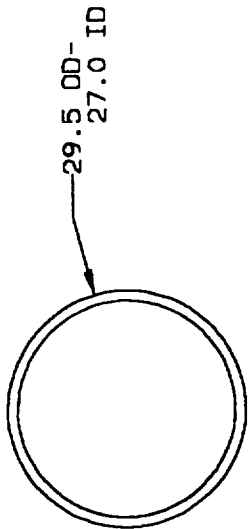

NOTE:  
1 MM ADDED  
FOR THERMAL  
EXPANSION

RINGS ARE CONSTRUCTED OUT  
OF TWO MATERIALS

- 1. INSULATIVE MATERIAL
- 2. CONDUCTIVE MATERIAL

1ST THREE RINGS ARE NON-COND.  
LAST RING NON-COND.

BINARY CODE IS EMBEDDED INTO RODS  
WITH THE USE OF RINGS

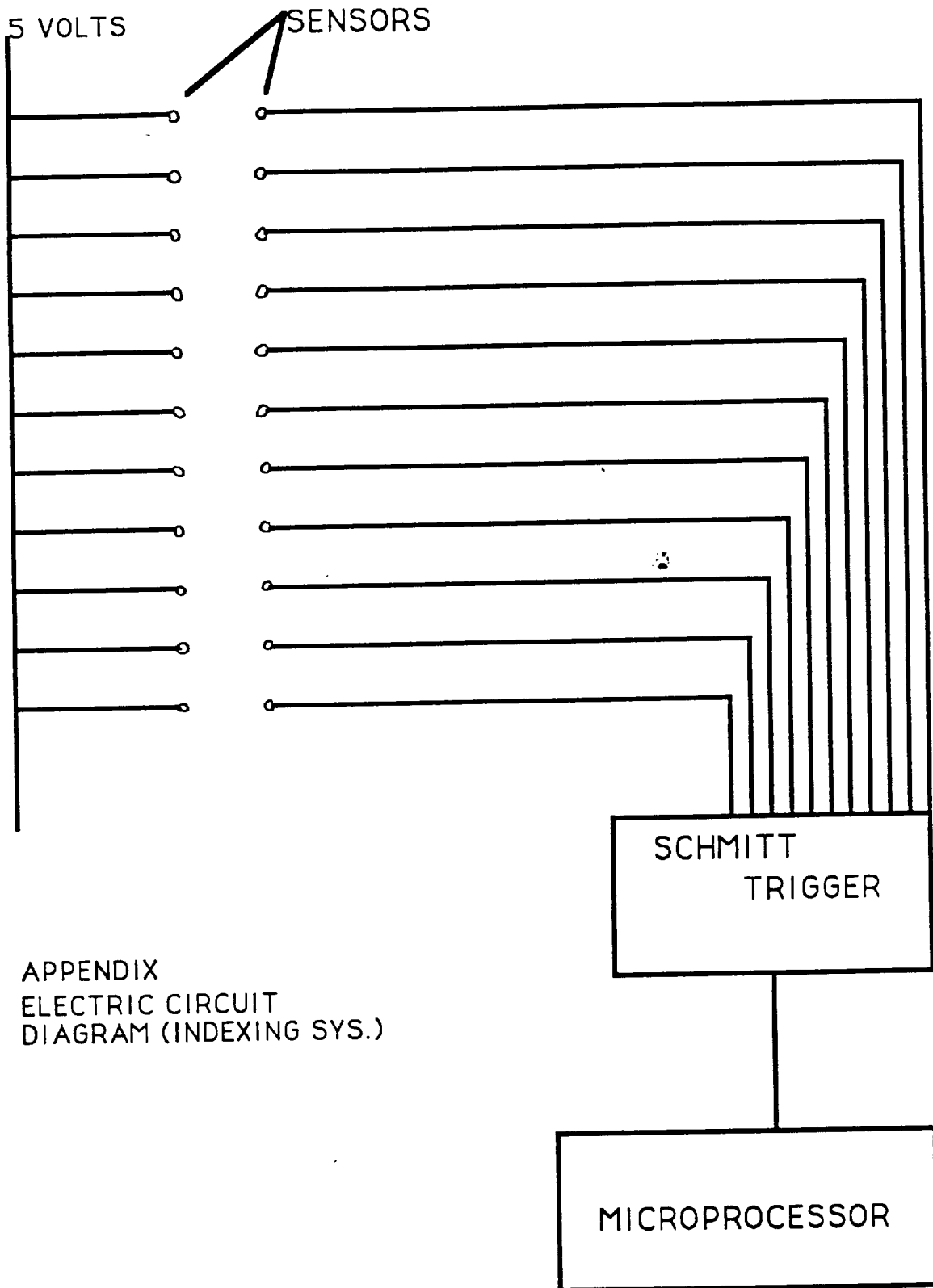

APPENDIX  
ELECTRIC CIRCUIT  
DIAGRAM (INDEXING SYS.)

# SCHMITT TRIGGER CIRCUIT

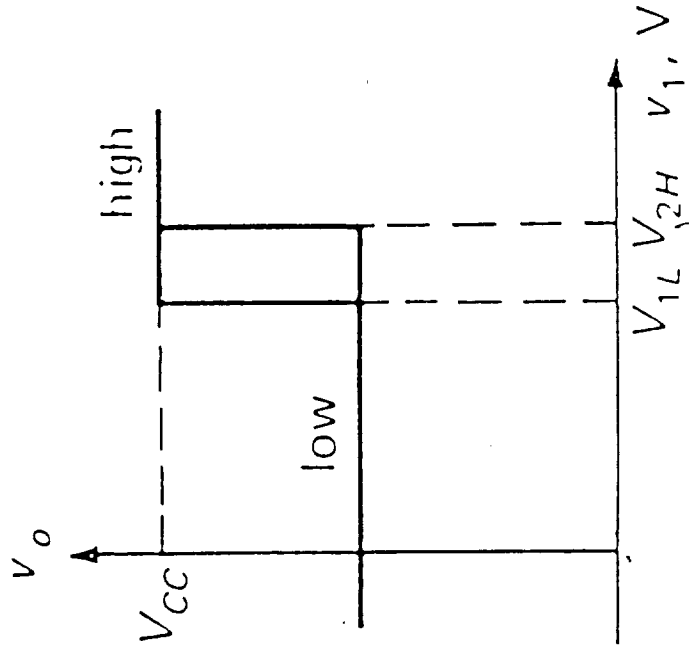
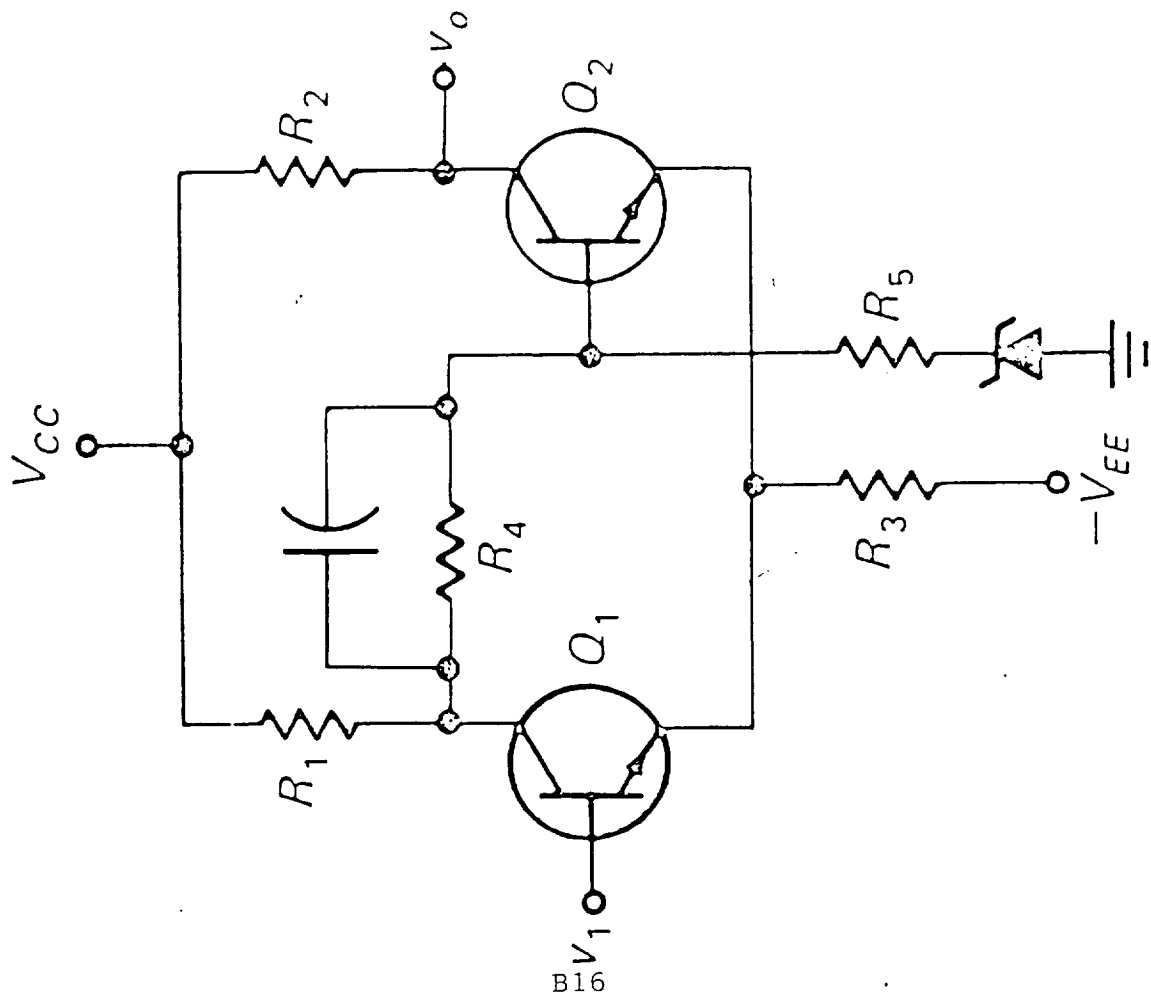

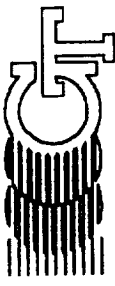

RACK DESIGN  
TOP FRAME I FOR CASING RACK

1 REQ.

FRAME CONTAINS 10 HOLES  
164 MM ON CENTER

RADII ARE TYPICAL

56 R

71 R

95 R

77 R

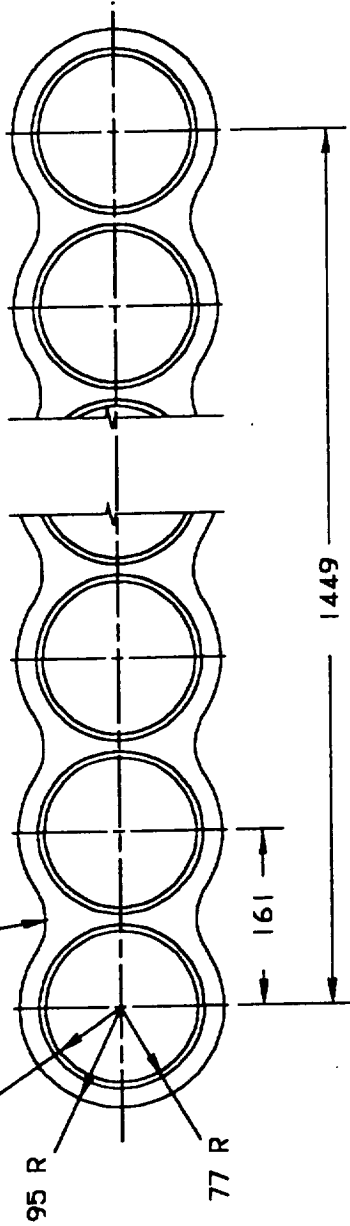

CONSTRUCTED FROM 2MM  
SHEET ALUMINUM

EDGE VIEW

BENDING RADII NOT TO  
EXCEED 2MM

TYPICAL PROFILE/ HOLE

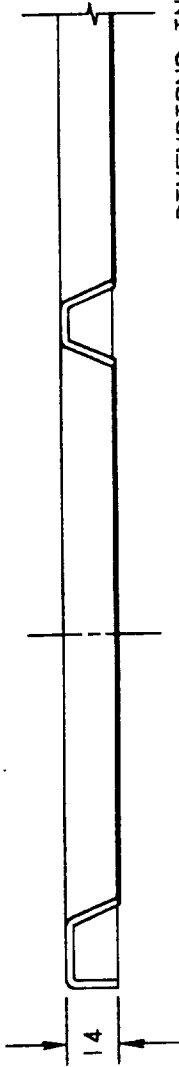

DIMENSIONS IN MM



RACK DESIGN  
STRUCTURAL FRAME II FOR CASING RACK

1 REQ.

FRAME CONTAINS 10 HOLES  
164 MM ON CENTER

RADII ARE TYPICAL

56 R

71 R

95 R

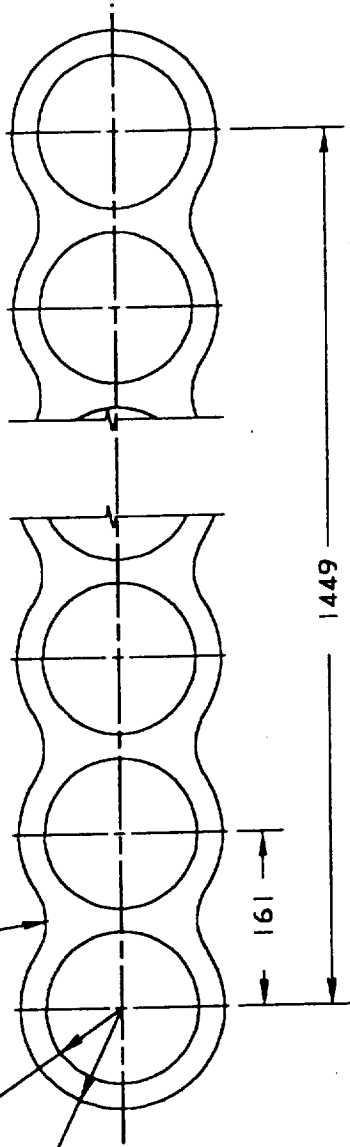

CONSTRUCTED FROM 2MM  
SHEET ALUMINIUM

EDGE VIEW

BENDING RADII NOT TO  
EXCEED 2MM

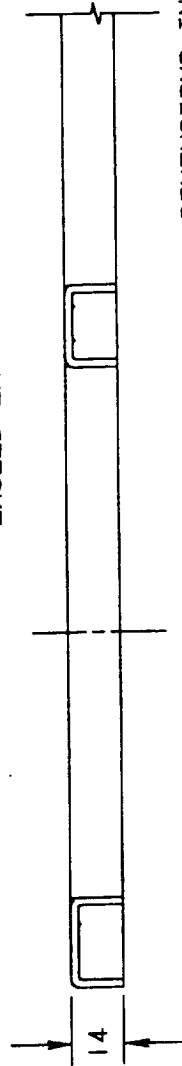

DIMENSIONS IN MM

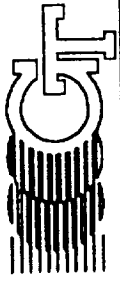

RACK DESIGN  
CASING TUBES

10 PIECES REQ.

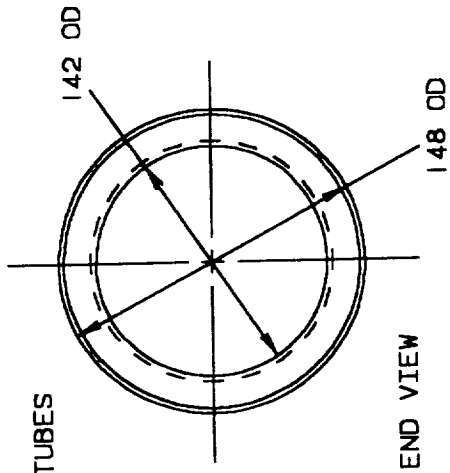

END VIEW

CONSTRUCTED FROM 1MM  
THICK TUBING

DIMENSIONS IN MM

SIDE VIEW

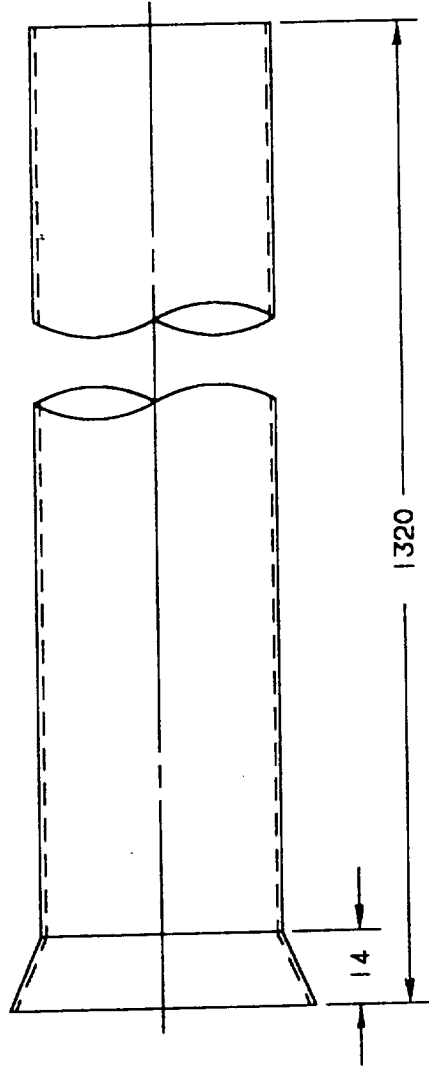

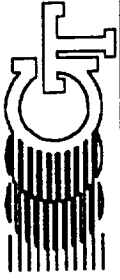

RACK DESIGN  
TOP FRAME I FOR TOOL RACK

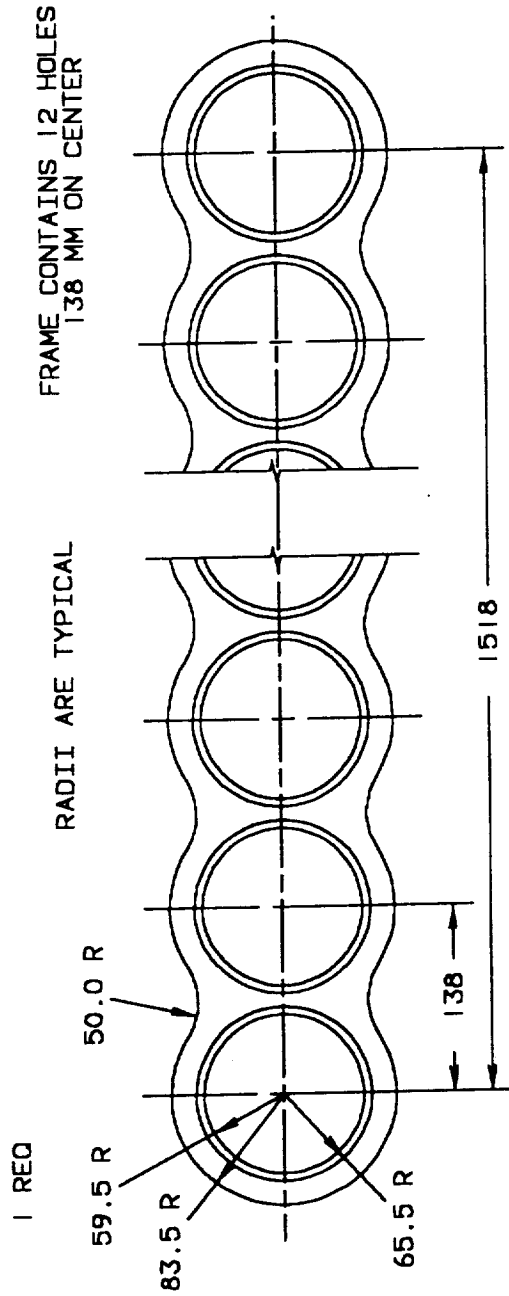

CONSTRUCTED FROM 2 MM  
SHEET ALUMINIUM

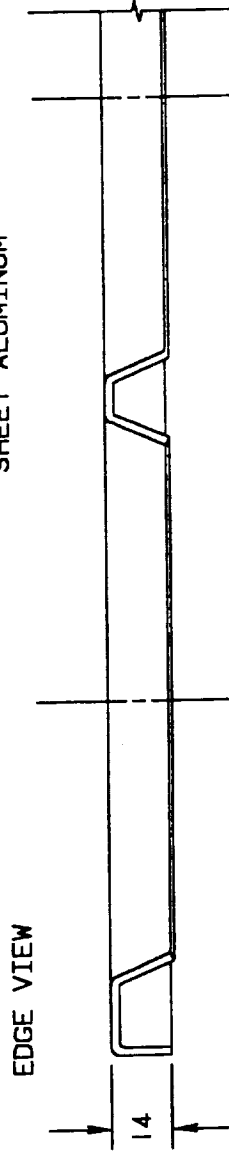

TYPICAL PROFILE/ HOLE      EXTERNAL BENDING RADII  
NOT TO EXCEED 2 MM      DIMENSION IN MM

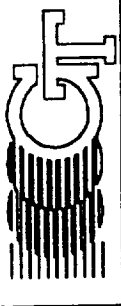

RACK DESIGN  
STRUCTURAL FRAME II FOR TOOL RACK

1 REQ

FRAME CONTAINS 12 HOLES  
138 MM ON CENTER

RADII ARE TYPICAL

59.5 R

83.5 R

50.0 R

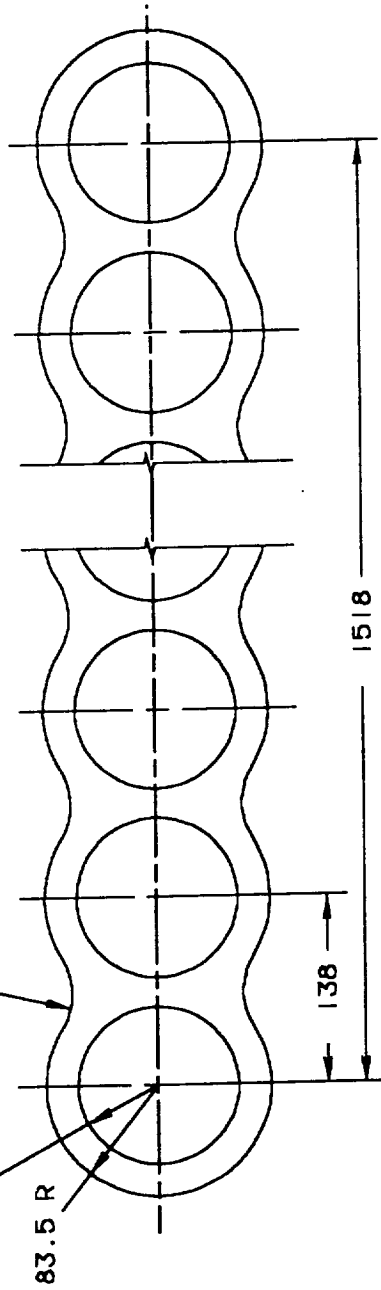

CONSTRUCTED FROM 2 MM  
SHEET ALUMINIUM

EDGE VIEW

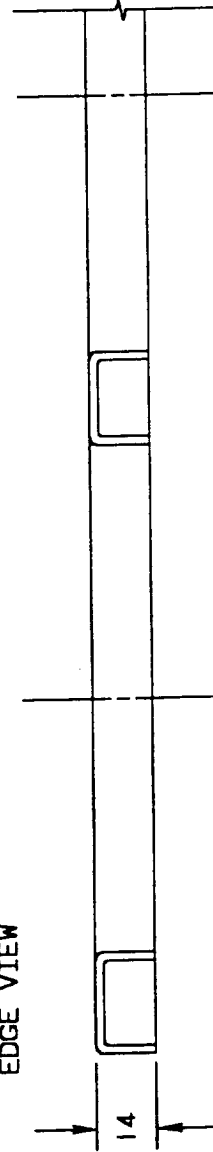

TYPICAL PROFILE/ HOLE

EXTERNAL BENDING RADII  
NOT TO EXCEED 2 MM

DIMENSION IN MM





RACK DESIGN  
TOOL TUBES

12 PIECES REQ.

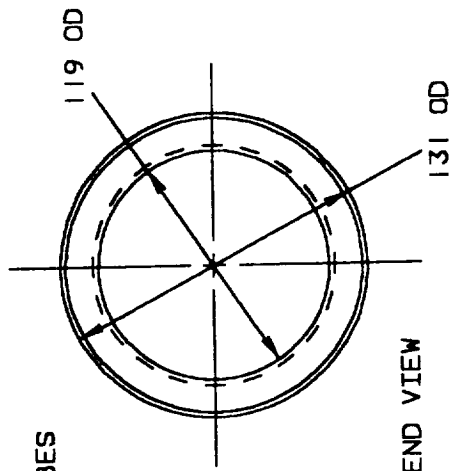

CONSTRUCTED FROM 1MM  
THICK TUBING

DIMENSIONS IN MM

SIDE VIEW

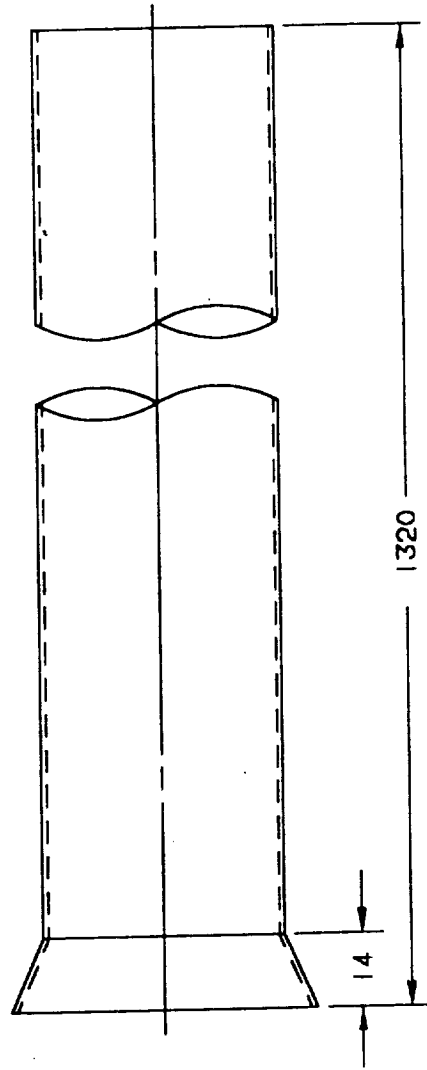

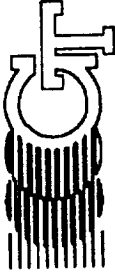

RACK DESIGN  
TOP FRAME I FOR ROD RACK

FRAME CONTAINS 26 HOLES  
64 MM ON CENTERS

RADIi ARE TYPICAL

I REQ.

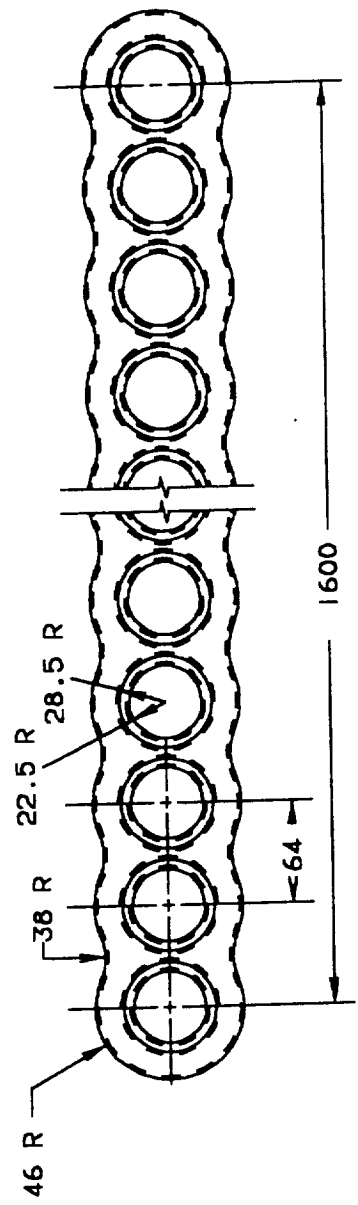

CONSTRUCTED FROM 2MM  
SHEET ALUMINUM

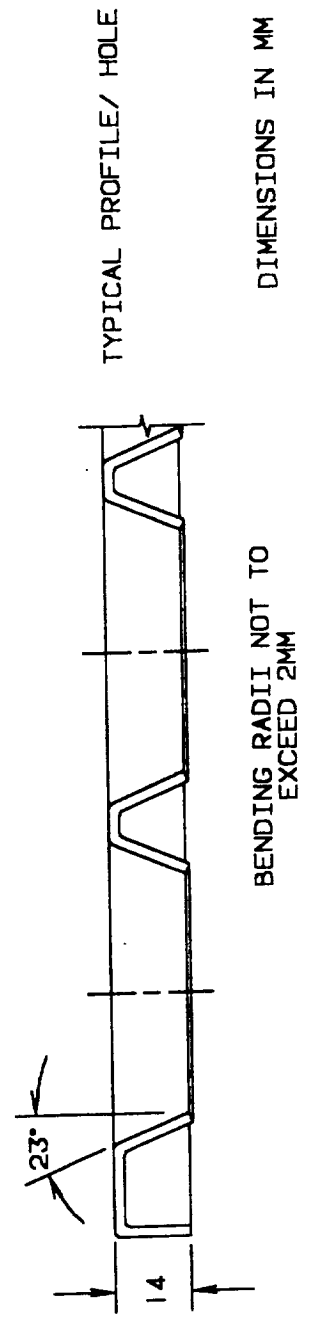



RACK DESIGN  
STRUCTURAL FRAME II FOR ROD RACK  
2 REQ.

FRAME CONTAINS 26 HOLES  
64 MM ON CENTERS

RADII ARE TYPICAL

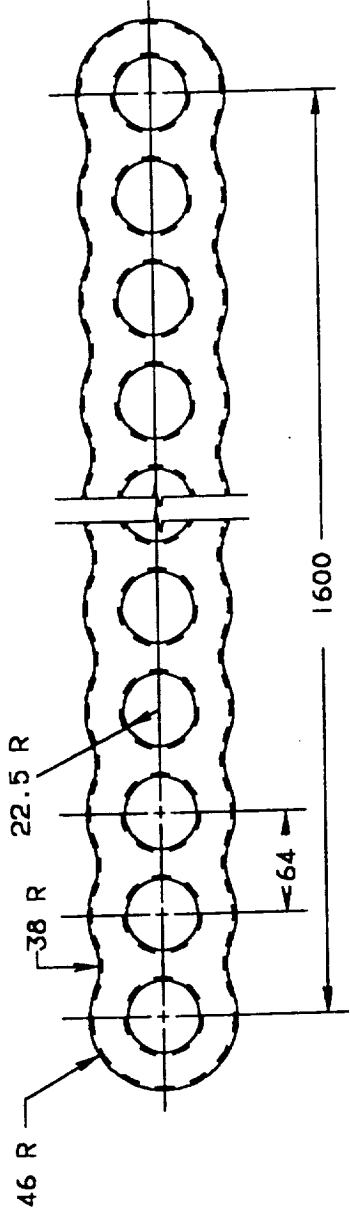

CONSTRUCTED FROM 2MM  
SHEET ALUMINUM

EDGE VIEW

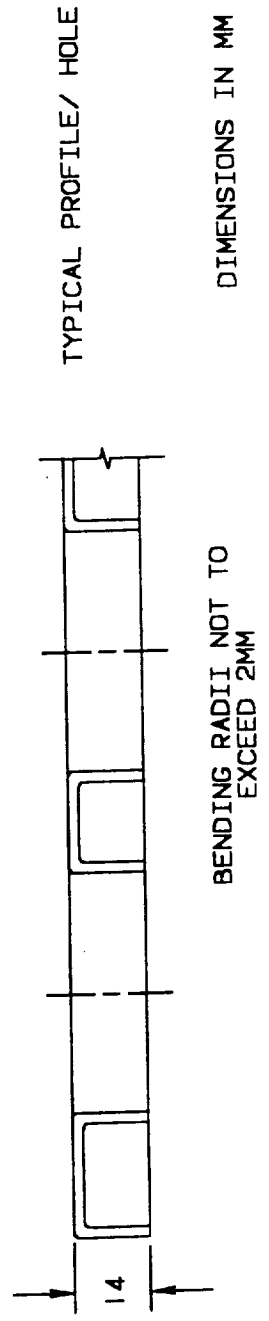



RACK DESIGN  
ROD TUBES

26 PIECES REQ.

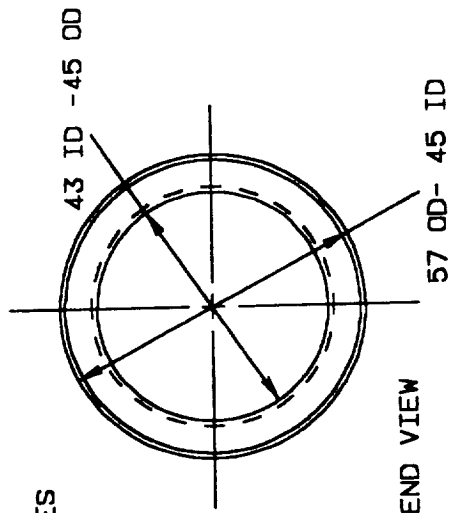

END VIEW

CONSTRUCTED FROM 1MM  
THICK TUBING

DIMENSIONS IN MM

SIDE VIEW

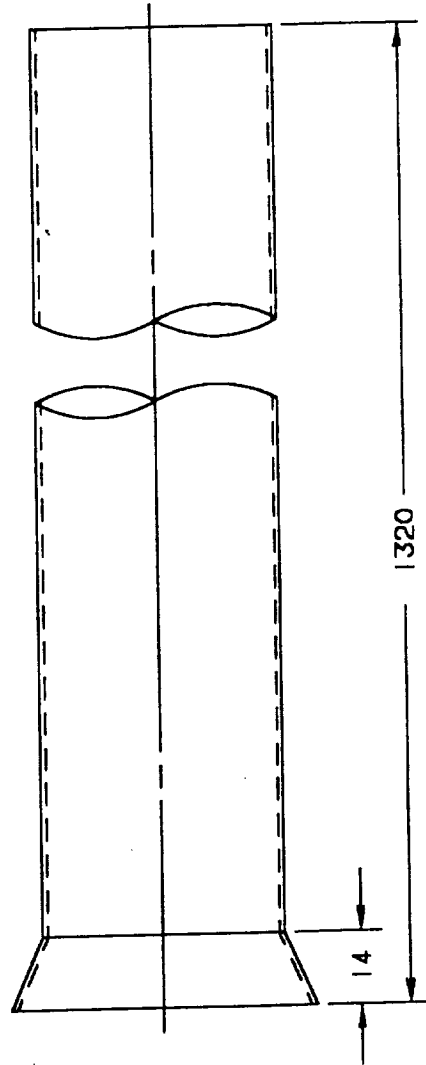

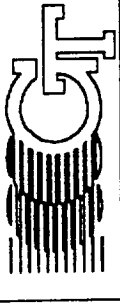

# EXTENSION ARM FOR RACK HANDLE

3 REQUIRED  
1 PER RACK

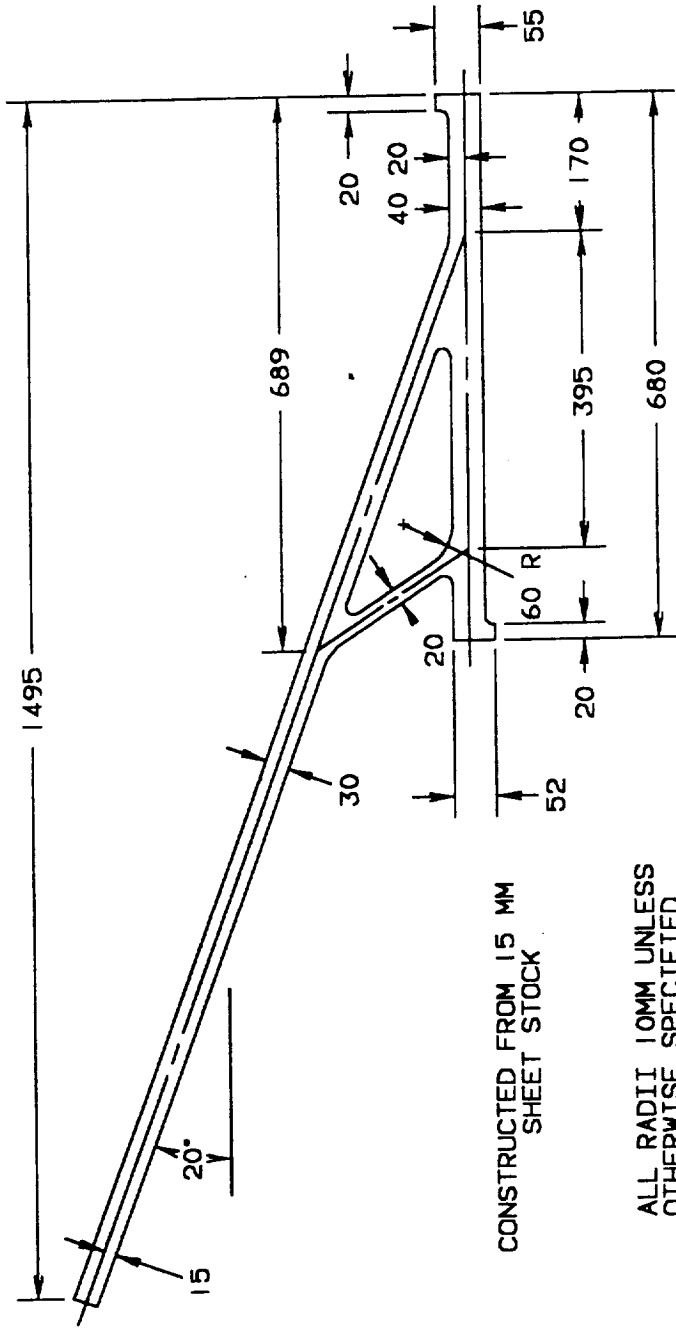

CONSTRUCTED FROM 15 MM  
SHEET STOCK

ALL RADII 10MM UNLESS  
OTHERWISE SPECIFIED

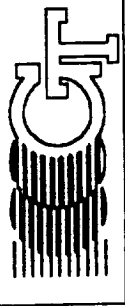

# LEFT SUPPORT BRACKET

3 PIECES REQ.

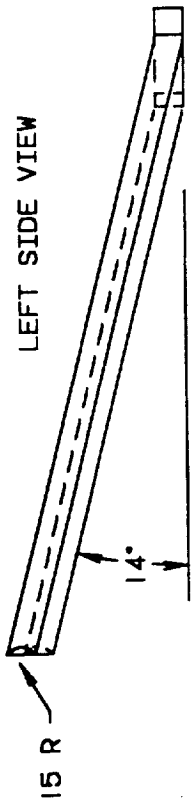

RIGHT SUPPORT BRACKET IS REFLEXIVE OF LEFT BRACKET

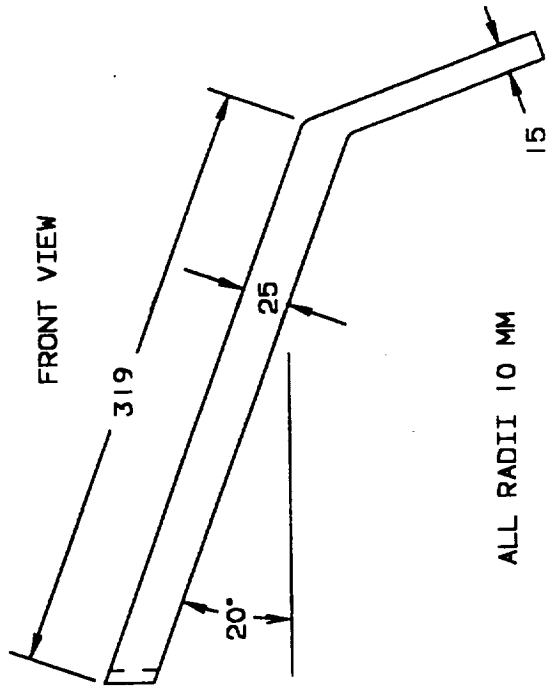
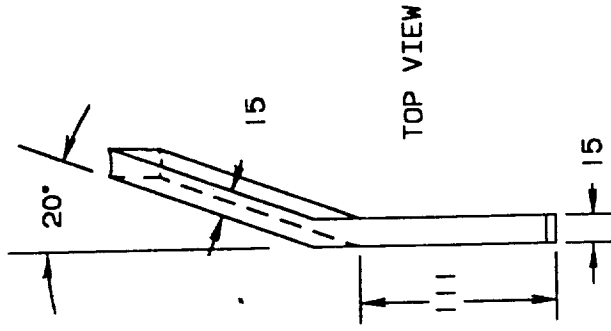

ALL RADII 10 MM

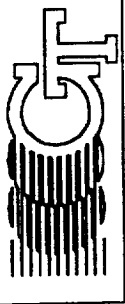

# LEFT SUPPORT BRACKET

3 PIECES REQ.

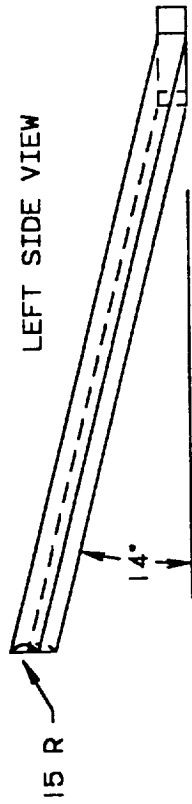

RIGHT SUPPORT BRACKET IS REFLEXIVE OF LEFT BRACKET

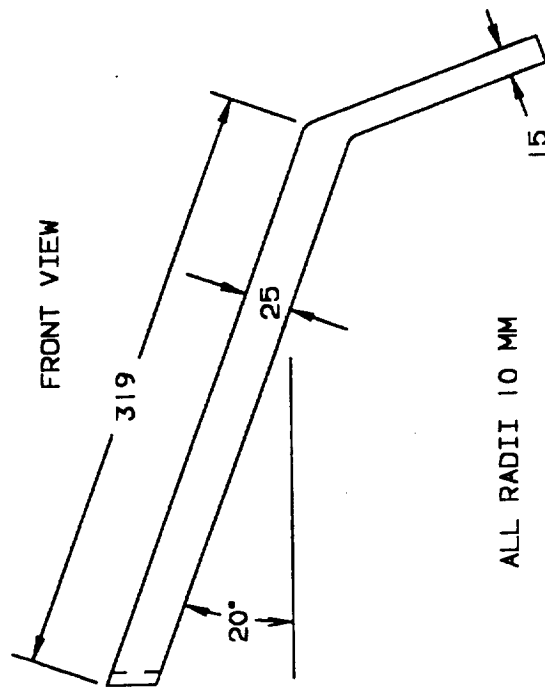
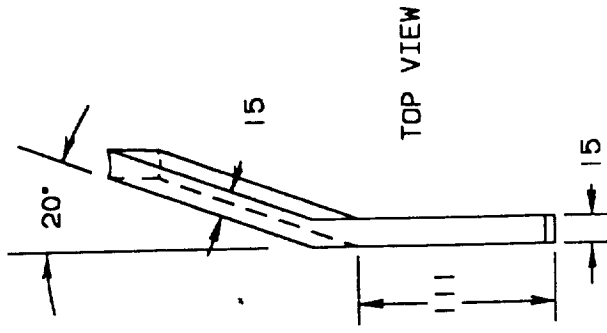

ALL RADII 10 MM



LEFT BRACKET

RIGHT SUPPORT BRACKET IS REFLEXIVE OF LEFT BRACKET

TOP VIEW

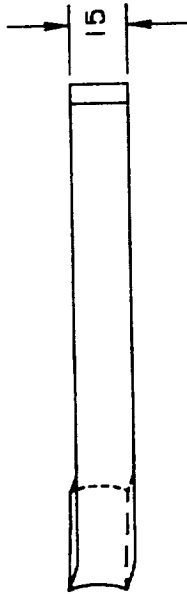

RIGHT VIEW

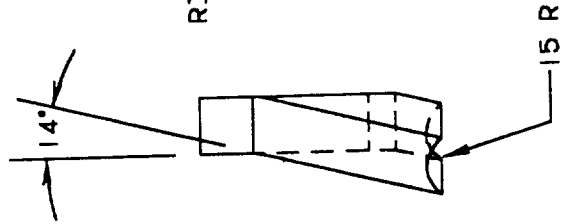

FRONT VIEW

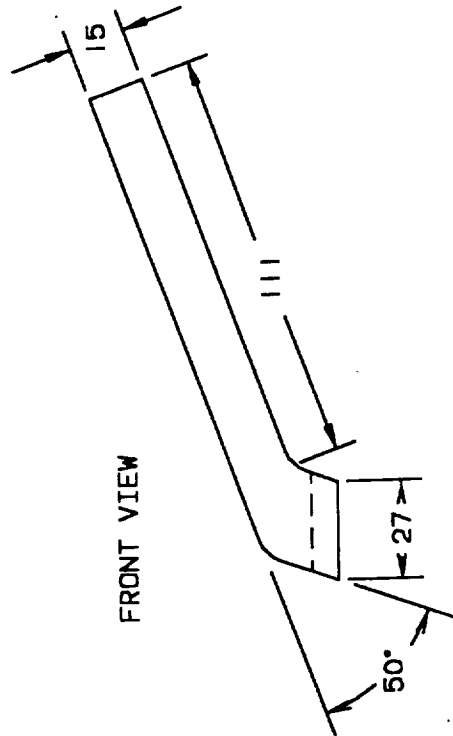





RACK DESIGN  
RACK FEET

6 PIECES REQ.

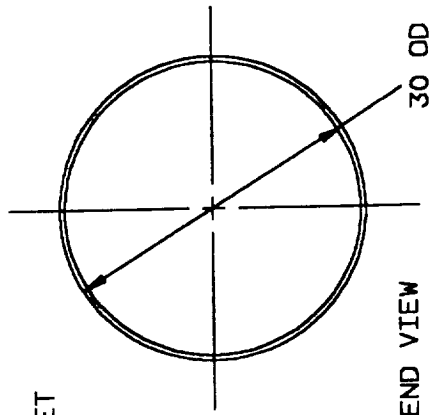

END VIEW

CONSTRUCTED FROM 2MM  
THICK TUBING

DIMENSIONS IN MM

SIDE VIEW

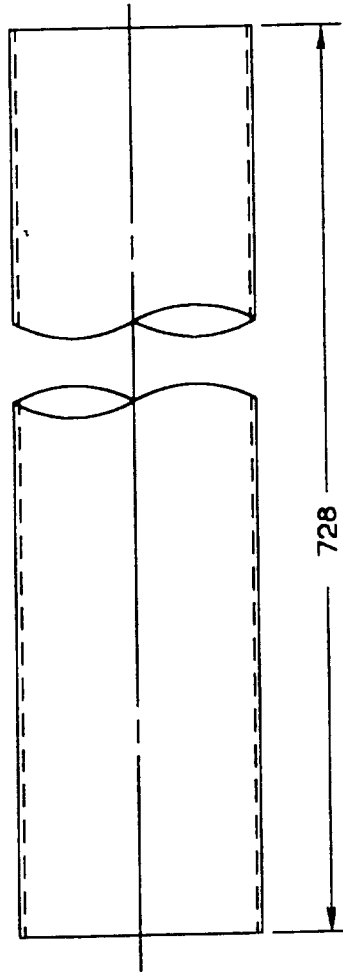

728



LEG PLACEMENT (W.R.T. EACH RACK)

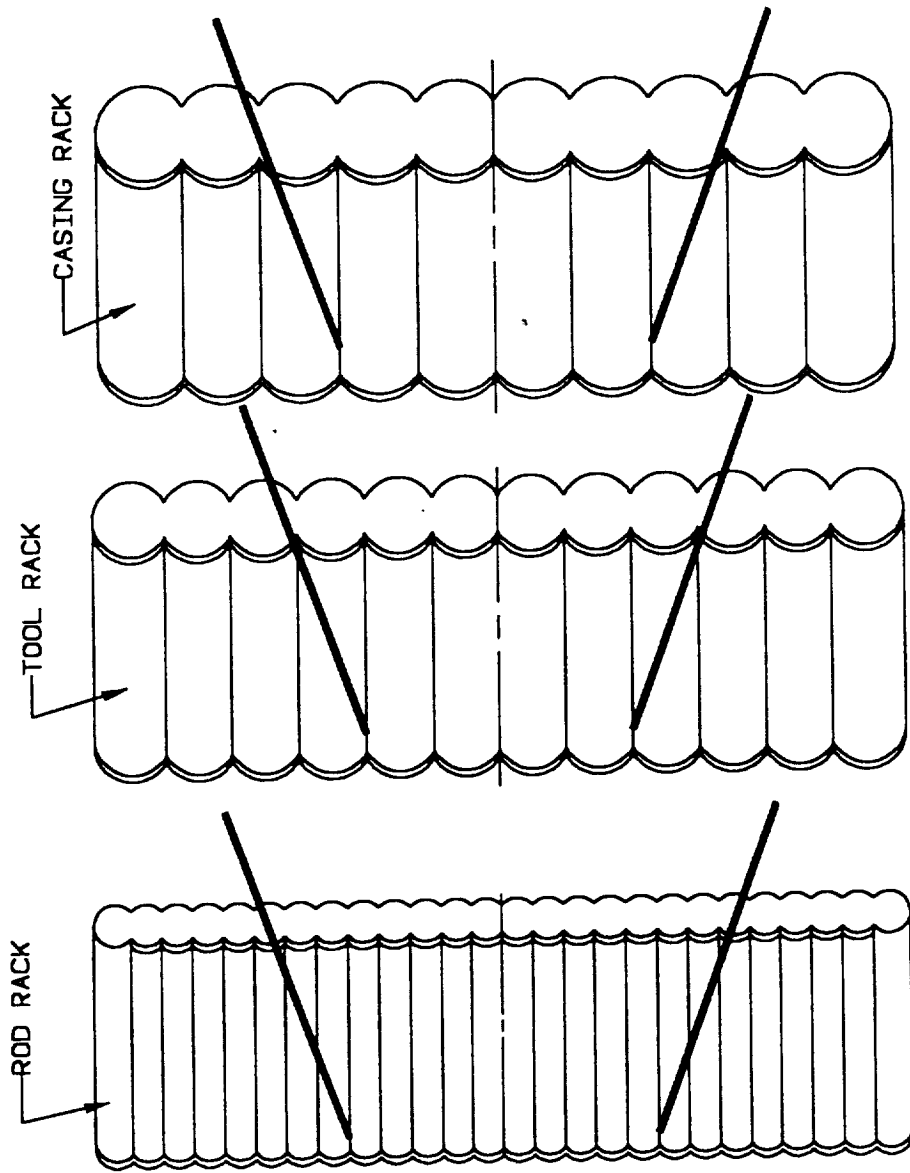

# Appendix C

## Alternative Designs



Thursday  
Feb 8, 1989

Mark Benson

"Two Arm"  
DESIGN

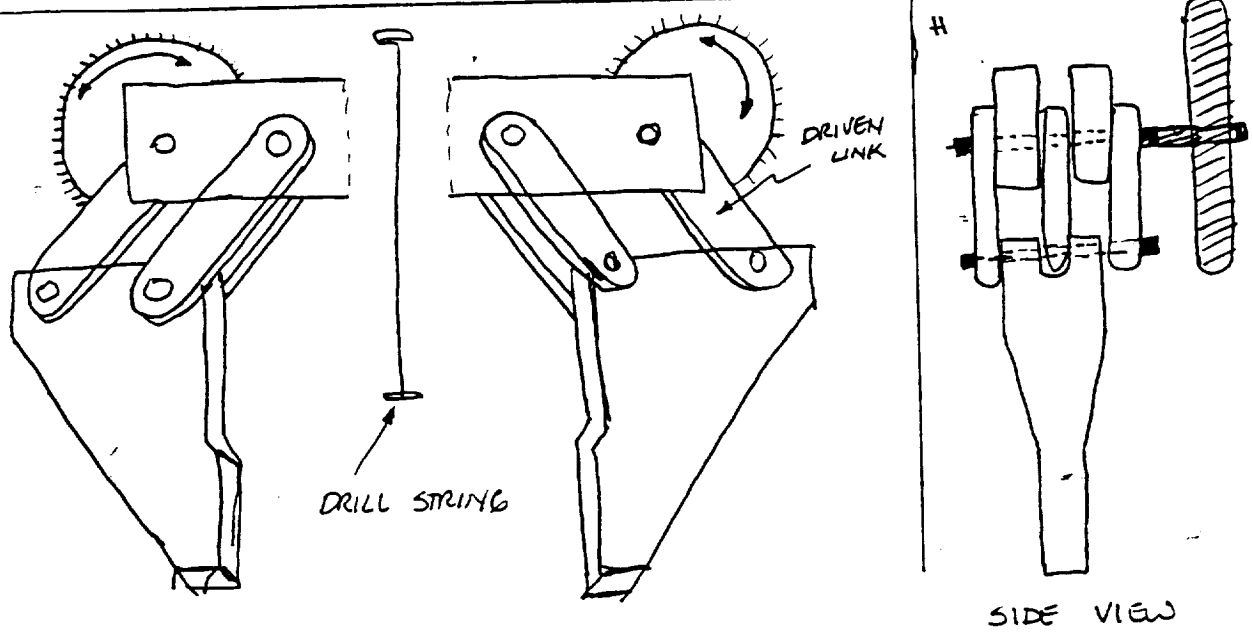
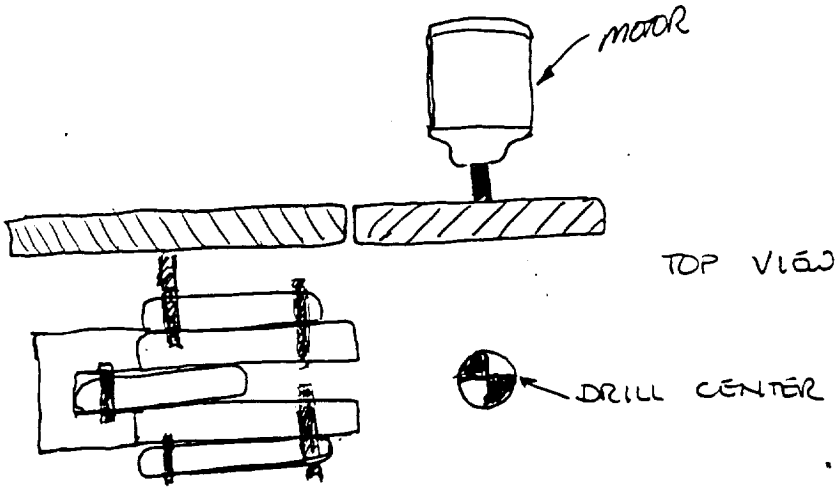

"GRIPPER SKETCH"

50 SHEETS \$ SQUARE  
100 SHEETS \$ SQUARE  
200 SHEETS \$ SQUARE  
NATIONAL

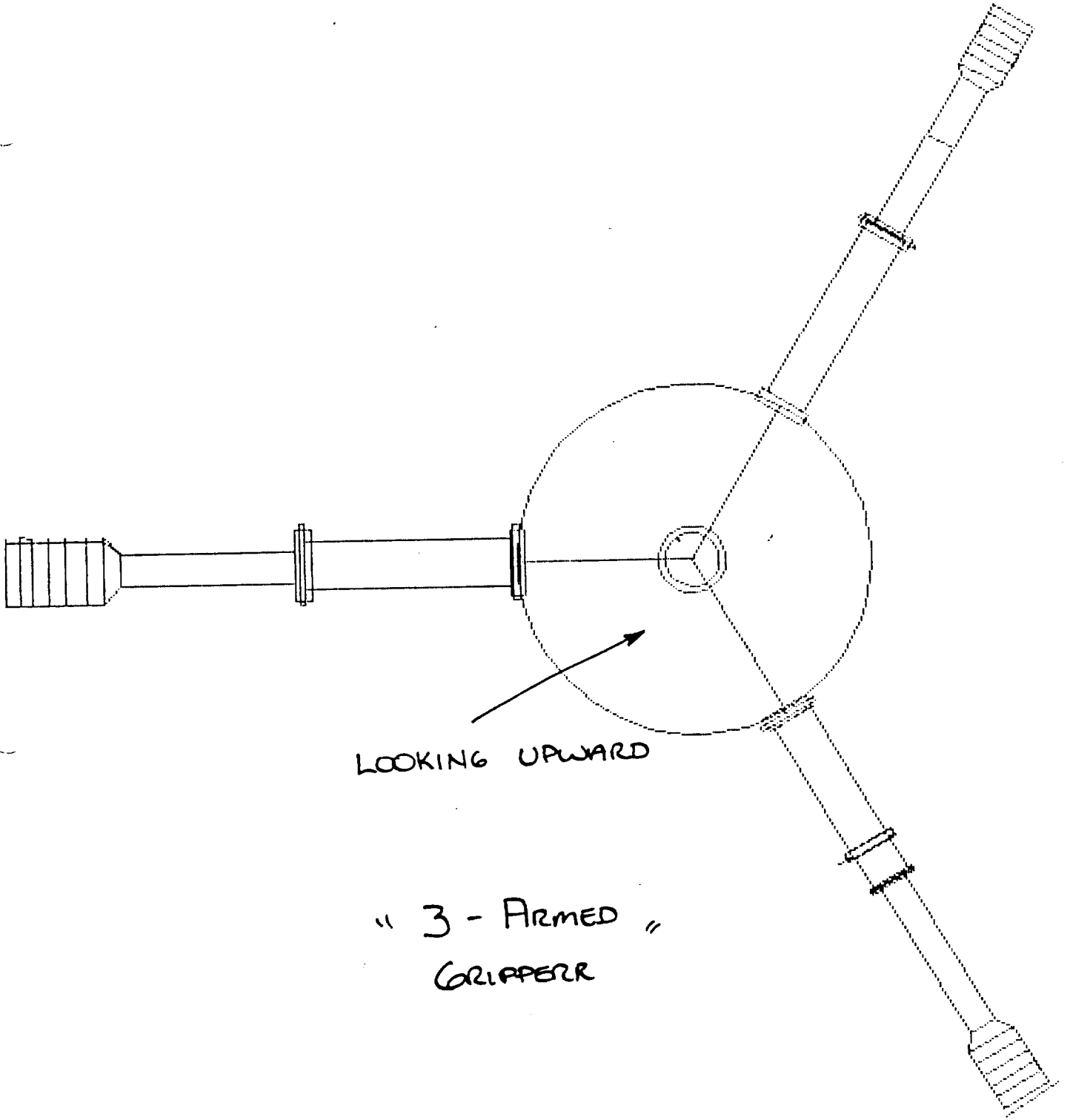

LOOKING UPWARD

" 3 - ARMED "  
GRIPPER

Team #2  
2/6/89  
Yuh R

TEAM #2

1/29/89

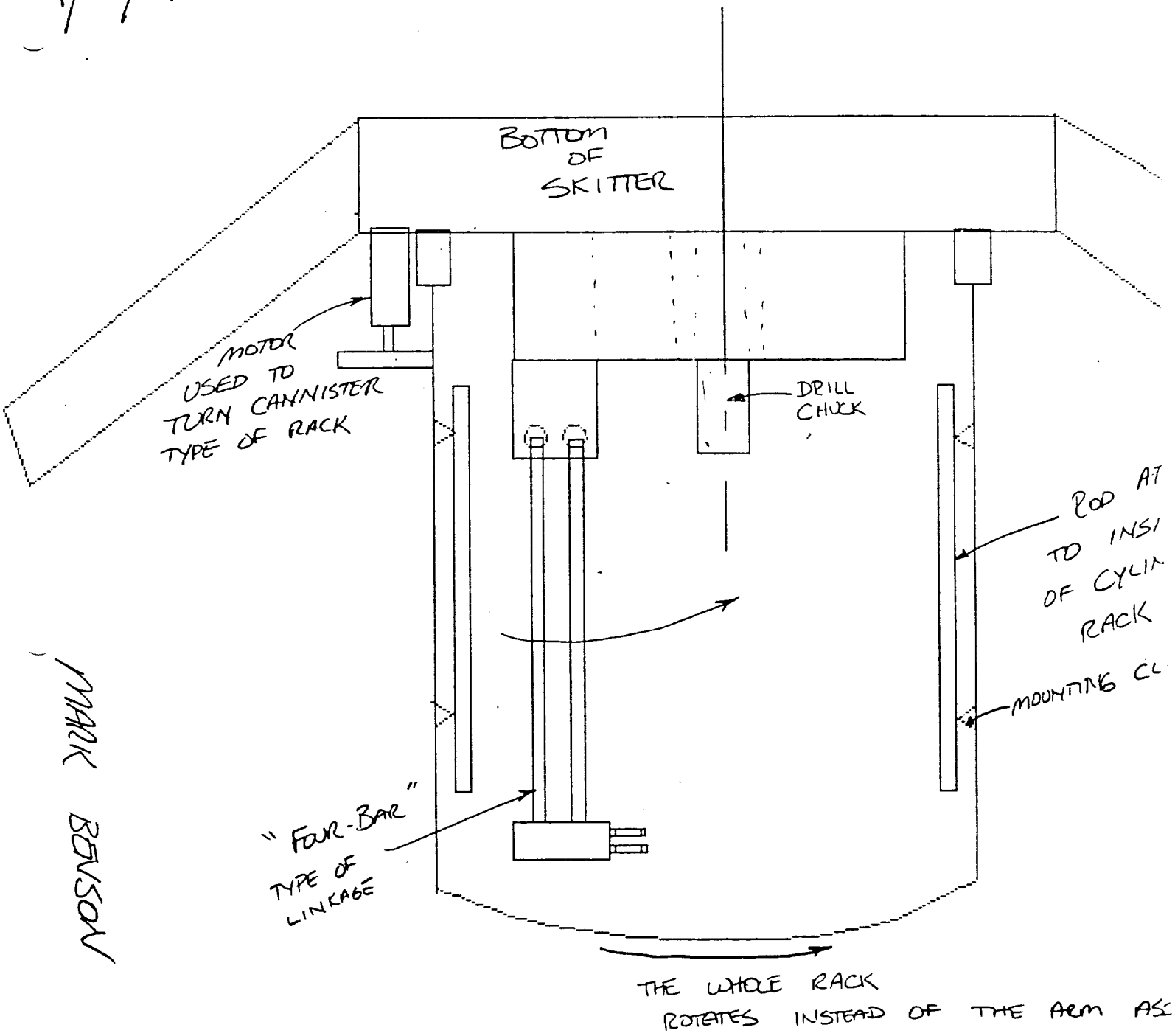

MARK BEVSON

TEAM # 2  
MARK BENSON  
2/15/89

" FOUR-BAR DESIGN "

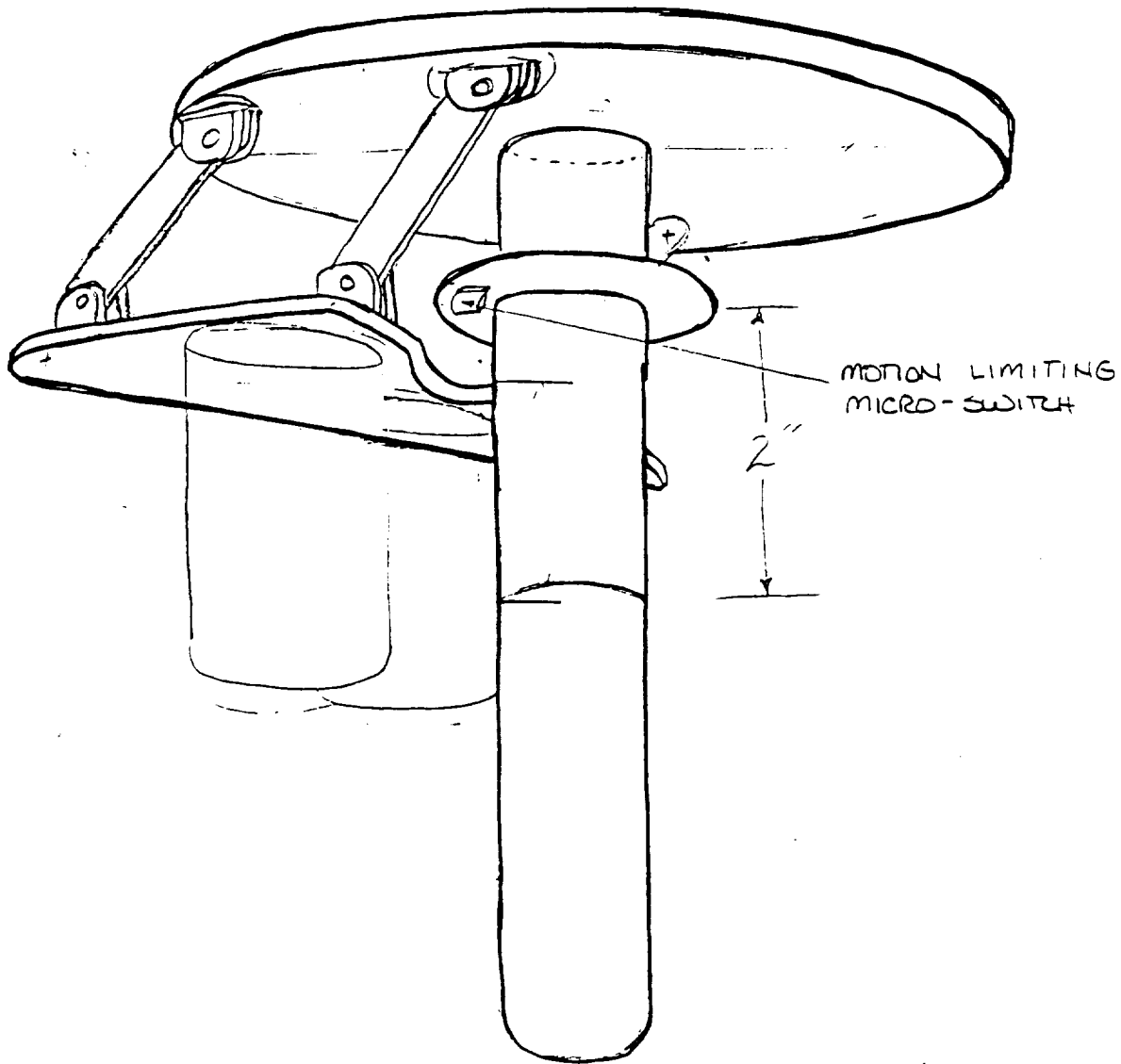

LIMITATIONS:

LINKS & JOINTS  
ARE EXPOSED TO  
LUNAR ENVIRONMENT



ALTERNATIVE DESIGNS  
INDEXING SYSTEM SENSOR

K.W.

SPRING LOADED BUTTONS ON THUMB  
BINARY CODED INDENTIONS IN ROD COUPLINGS

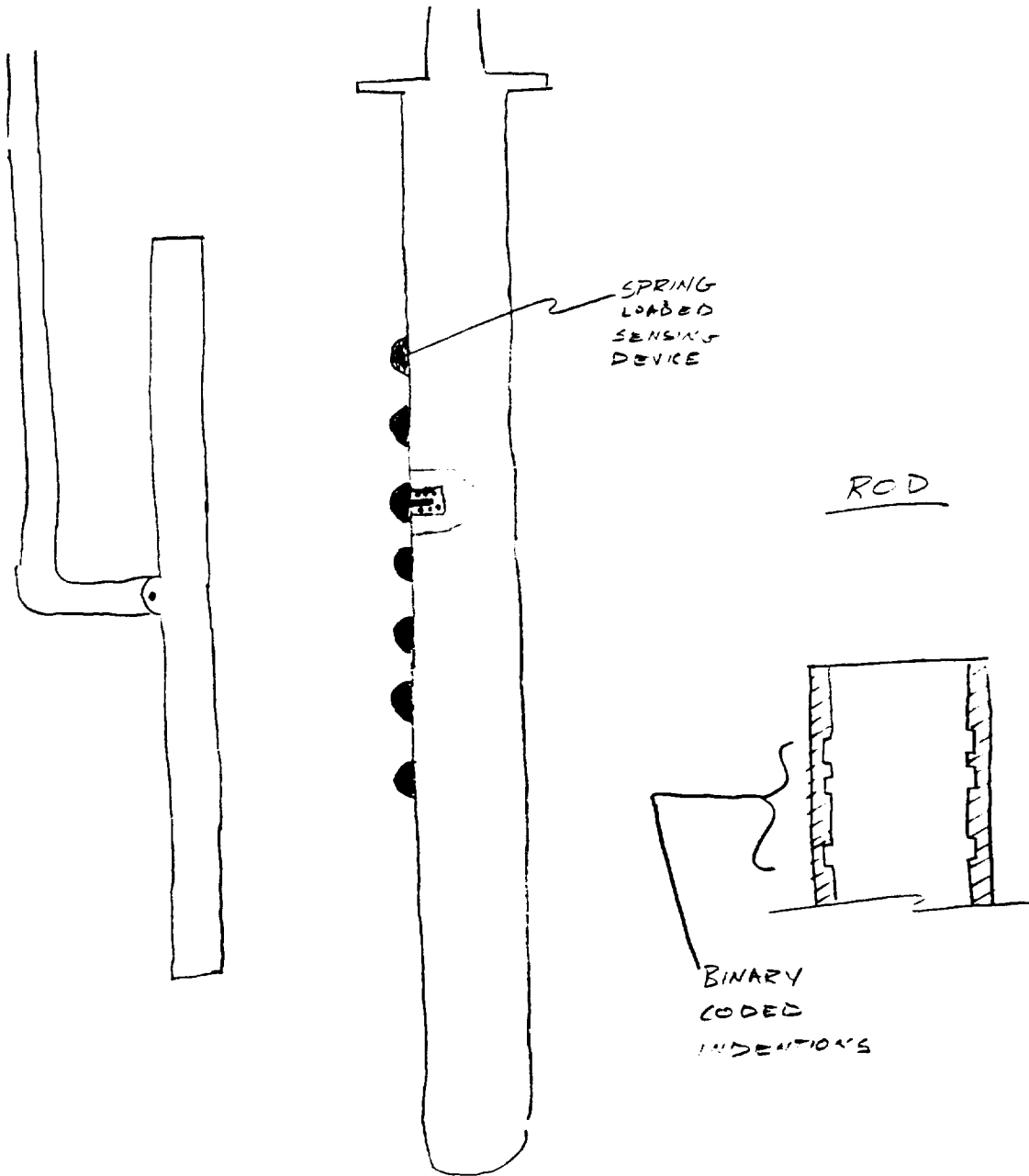

ALTERNATIVE DESIGN

Kv1.

INDEXING SYSTEM SENSOR

MECHANICAL ROLLER SENSER DETECTS  
INDENTATION IN THE ROD AS THE  
THUMB IS INSERTED.

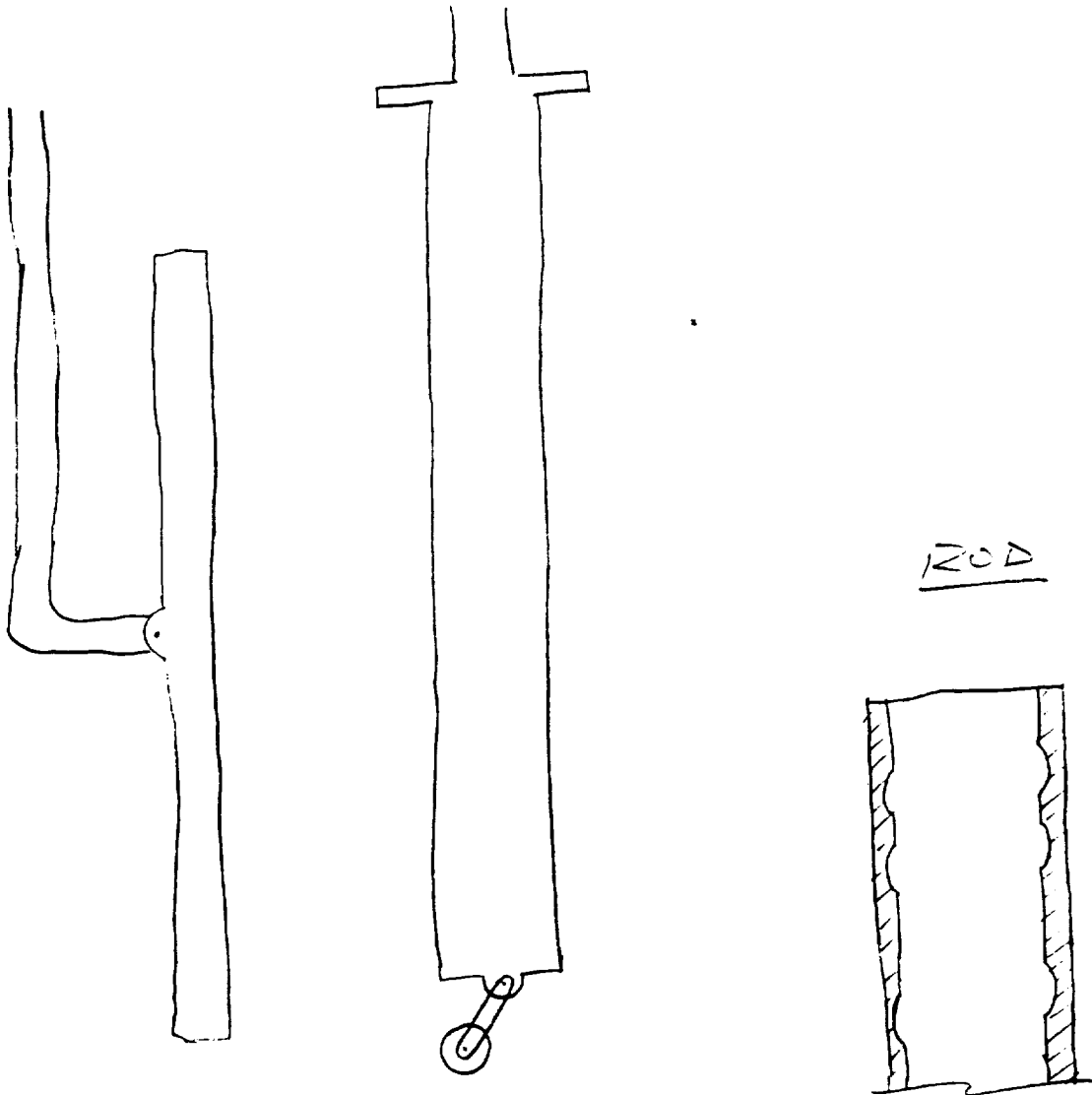

K.W.

ALTERNATIVE DESIGNS  
INDEXING SYSTEM SENSOR

ELECTRICAL RESISTANCE SENSOR  
EACH IMPLEMENT HAS A DIFFERENT RESISTANCE

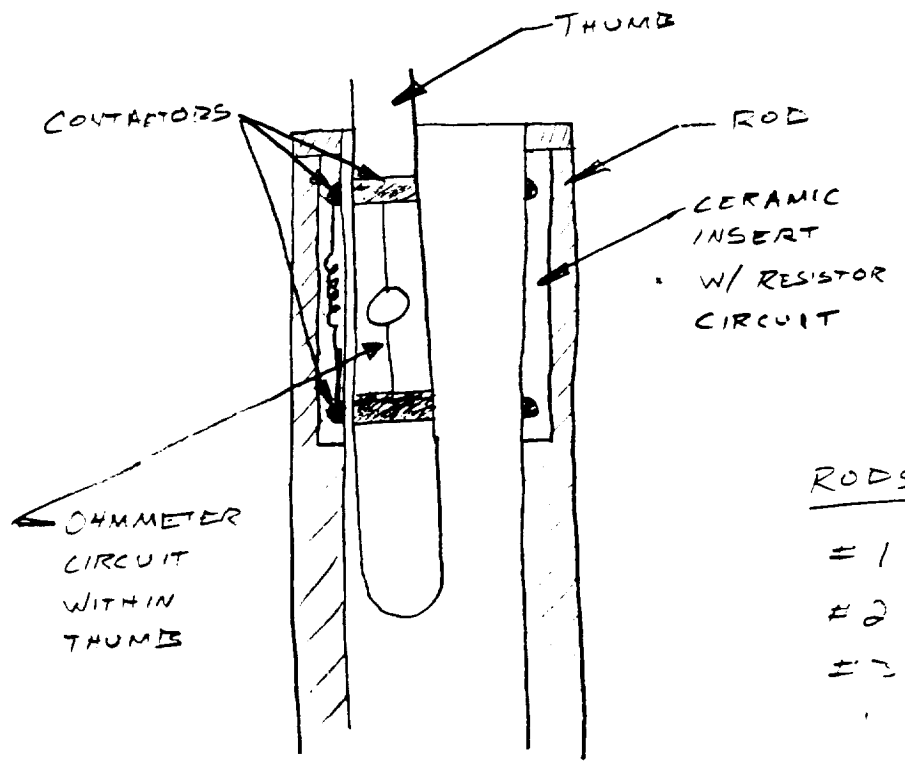

<u>RODS</u>	(100kΩ)
#1	101kΩ
#2	102kΩ
#3	103kΩ
	⋮

CASING - 10Ω

NEEDS:

- TEMPERATURE SENSOR
- VERY SMALL RESISTORS
- SMALL SCALE MACHINING

<u>AUGER</u>	(1000kΩ)
#1	1010kΩ
#2	1020kΩ
#3	1030kΩ
	⋮

1

2

3