

## TENSILE AND SHEAR STRENGTH OF ADHESIVES

Kenneth A. Stibolt  
Anne Arundel Community College  
Arnold, Maryland

### PREREQUISITES

This experiment is conducted in a freshman-level course: Introduction to Engineering Materials. There are no pre-requisites for the course although students should have some knowledge of basic algebra.

### OBJECTIVES

1. To tension and shear test adhesives.
2. To determine the tensile and shear properties of adhesives.

### EQUIPMENT AND SUPPLIES

Tension testing machine.  
Flat plate jaws for testing adhesive shear specimens.  
Rod jaws for testing adhesive tension specimens.  
Adhesive shear specimens.  
Adhesive tension specimens.  
Vernier calipers.

### PROCEDURE

1. Measure dimensions of adhesive contact area for tension and shear specimens (mm).
2. Calculate contact area of tension and shear specimens and record results (mm<sup>2</sup>).
3. Install flat plate jaws in tension testing machine.
4. Mount adhesive shear specimen in flat plate jaws.
5. Slowly increase load on specimen until adhesive fails in shear. Note and record ultimate load (N).
6. Repeat steps 4 and 5 for the remaining adhesive shear specimens.
7. Install the rod jaws in tension testing machine.
8. Mount adhesive tension specimen in rod jaws.
9. Slowly increase load on specimen until adhesive fails in tension. Note and record ultimate load (N).
10. Repeat steps 8 and 9 for the remaining adhesive tension specimens.

## RESULTS

1. Calculate ultimate tension and shear stress for all specimens (Pa).
2. Tabulate adhesive type, load type and ultimate stress.
3. Establish some conclusions about the effectiveness of the various adhesives tested relative to the material bonded.
4. Establish some conclusions about the load type (tension or shear) producing the best adhesive performance.

## NOTES TO INSTRUCTORS

This experiment is best conducted on a tension testing machine with mounting jaws available for testing flat plate and rod specimens. Figure 1 shows the adhesive tension specimen. Figure 2 shows the shear specimens. Both are made from readily available aluminum. Dimensions of the specimens can be adjusted to the availability of material and load capacity of the tension testing machine.

Using a variety of adhesives will make the experiment more interesting. Purchasing types used in the home and in construction is easy. Obtaining types used for industrial manufacturing is more difficult. Lead time for bonding together tension and shear specimens should be long enough for adhesives to develop their full strength. Try to have similar surface finishes and clamping pressures for all specimens.

After the specimens are tested, many can be reused by removing adhesive and establishing a new substrate. This can be accomplished by wire brushing, surface grinding or sanding.

This experiment investigates the effect of load type and adhesive on ultimate strength. Other test variables can be introduced such as substrate type (wood and plastic), surface finish, cure variables and environmental conditions.

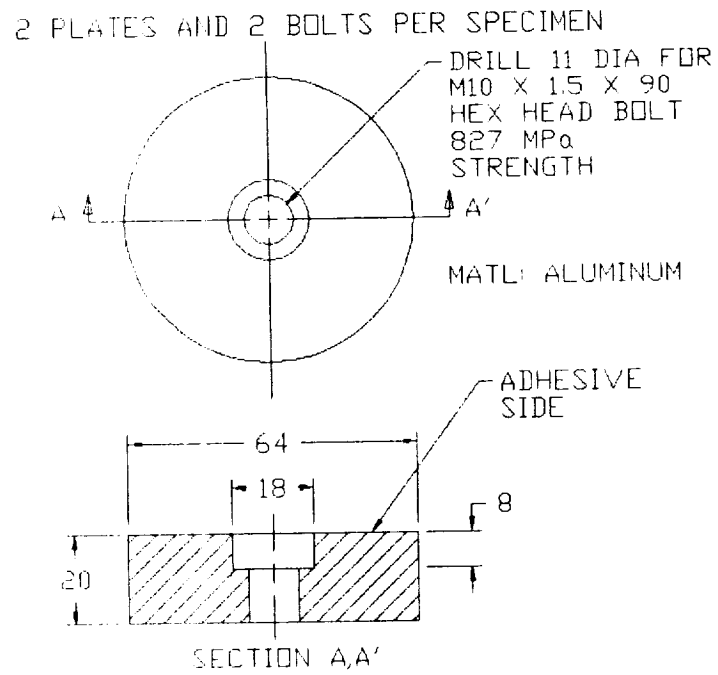
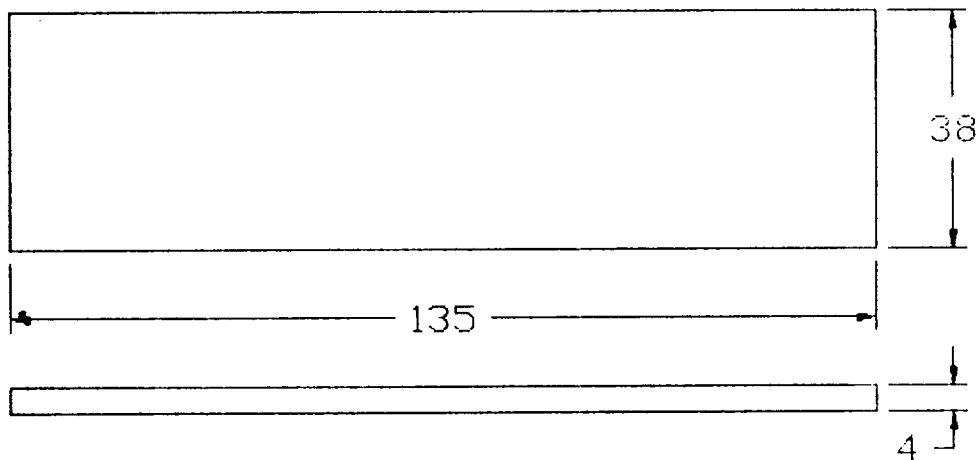

FIGURE 1

Adhesive Tension Specimen



MATERIAL: ALUMINUM  
2 PLATES PER SPECIMEN  
OVERLAP PLATES 38 mm FOR SPECIMEN

FIGURE 2

Shear Specimen

