

CHEMISORPTION STUDIES OF Pt/SnO₂ CATALYSTS

Kenneth G. Brown, Susan K. Ohorodnik, John D. Van Norman
and Jacqueline Schryer, Department of Chemistry,
Old Dominion University, Norfolk, Va

Billy T. Upchurch and David R. Schryer
NASA-Langley Research Center
Hampton, Va

INTRODUCTION

The low temperature CO oxidation catalysts that are being developed and tested at NASA-Langley are fairly unique in their ability to efficiently oxidize CO at low temperatures (~303K). The bulk of the reaction data that has been collected in our laboratory has been determined using plug flow reactors with a low mass of Pt/SnO₂/SiO₂ catalyst (~0.1g) and a modest flow rate (5 - 10 sccm). We have previously characterized the surface solely in terms of N₂ BET surface areas. These surface areas have not been that indicative of reaction rate. Indeed, some of our formulations with high BET surface area have yielded lower reaction rates than those with lower BET surface areas. As a result we have begun a program, initially described at the previous NASA/RSRE conference(1), of determining the chemisorption of the various species involved in the reaction; CO, O₂ and CO₂. Such a determination will lead to a better understanding of the mechanism and overall kinetics of the reaction.

The pulsed-reactor technique, initially described by Freel (2,3), is used to determine the amount of a particular molecule that is adsorbed on the catalyst. Since there is some reaction of CO with the surface to produce CO₂ the pulsed reactor had to be coupled with a gas chromatograph in order to distinguish between the loss of CO that is due to adsorption by the surface and the loss that is due to reaction with the surface. The experimental apparatus and the technique used to determine the number of moles adsorbed is described in the next section.

METHODS

The experimental system consists of an Shimadzu Gas Chromatograph (GC) which is equipped with a Thermal Conductivity Detector (TCD). The GC column acquired from ALLTECH® is two concentric tubes, the inner tube being filled with molecular sieve while the outer column is filled with a porapak mixture. The output from the detector is recorded on a Shimadzu CR5A integrating recorder.

The catalyst sample is contained in a stainless steel tube of 1/8" O.D. The catalyst is held between two stainless steel frits, as shown in figure 1. This tube, which is located immediately upstream of the column, is placed in a small oven which is mounted on the front of the GC. The temperature of the

catalyst can be controlled to within 0.5 C. The flow rate through the catalyst and column is 20 sccm and is monitored by a Hastings mass flow controller. All gases were High Purity. The gas mixtures all contained 2% Ne as an internal standard. These mixtures were prepared gravimetrically by Scott. The carrier gas, high purity Helium, was obtained from Union Carbide, Linde Division.

A flow schematic of the entire system is shown in figure 2. An empty tube is located in the reactor oven in addition to the tube containing the catalyst. We can switch between this tube and the reactor tube to provide an initial calibration of the system and to monitor system conditions as the reaction progresses. With this system we are able to expose the catalyst to all of the reaction conditions that have been previously used to study the reaction. We can pretreat the catalyst using our accepted procedure of 5% CO in He at 125 C for one hour. At the end of the pretreatment we can allow the catalyst to cool under Helium flow to the desired temperature. At that time we can begin introducing 1 cc pulses of the desired gas mixture onto the catalyst surface. Since it takes approximately 8 minutes to take the complete chromatogram the pulses are separated by 8 minutes. The sample is pulsed with the gas of interest until the area of the observed peak is identical to that obtained from the bypass measurements, as shown in figure 3 or until there is no discernible change in the CO concentration.

The catalyst samples were prepared at NASA-Langley using the synthetic technique described elsewhere in this issue. The particular catalysts used in this study have the following compositions by weight per cent: 1.) 5.8% Pt, 39.96% SnO₂, 54.24% SiO₂ (5%Pt/SnO₂/SiO₂); 2.) 19.5% Pt, 80.5% SnO₂(19%Pt/SnO₂); 3.) 8.55% Pt, 8.60% Pd, 35.1% SnO₂, 47.6% SiO₂(9%Pt,9%Pd/SnO₂/SiO₂). A 2%Pt/SnO₂ sample was obtained from Englehard Industries. In this paper these catalysts will also be referred to as 5% Pt, 19% Pt, 9% Pt/Pd, and 2% Pt respectively.

The BET surface areas reported herein were obtained at NASA-Langley with a Quantasorb[®] apparatus using N₂ as the adsorbate.

RESULTS

CO ADSORPTION

The fraction of CO remaining in the gas mixture as a typical experiment progresses for both a non-pretreated and a pretreated catalyst is shown in figures 4 and 5. The changes in CO are the result of both CO adsorption and the reaction of CO with the surface to produce CO₂. In both the non-pretreated and pretreated cases the initial pulses result in a significant amount of CO₂ production, as shown in figure 6. After 400 min. (approximately 50 pulses) for the non-pretreated catalyst and 100 min. (approximately 12 pulses) for the pretreated catalyst most of the processes affecting the freestream composition have ceased and the CO concentration approaches the bypass level. The fraction of CO in the freestream does not attain the original concentration but remains below that value for times of exposure that have been

as long as 1000 min. in the case of the non-pretreated sample. CO₂ production is essentially finished in the pretreated sample after approximately 50 min. (approximately 6 pulses).

Figures 7 and 8 summarize the CO₂ production observed for all of the catalysts employed in this study. The most persistent CO₂ production occurred with the 19% Pt catalyst which also exhibits a sharp reduction in CO₂ production at 400 min. (50 pulses). After pretreatment this particular catalyst exhibited no CO₂ production. The other non-SiO₂ supported catalyst, 2% Pt, did not behave in the same manner. It continued to produce CO₂ after 400 min. in the non-pretreated case and it has the highest initial CO₂ production after pretreatment. With or without pretreating the 9%Pt/Pd catalyst is the most persistent producer of CO₂.

Correcting for the amount of CO₂ produced we can determine the amount of CO that remains chemisorbed on the surface. The total amount chemisorbed is then determined by adding the amount adsorbed per pulse until the adsorption process ceases. The point at which chemisorption ceases is taken to be when the CO freestream concentration attains a constant value. This point is determined graphically as the intersection between the curved portion of the chemisorption curve with the line extended from the level portion of the graph.

The number of moles of CO that are chemisorbed can then be used to determine the number of Pt atoms exposed on the surface assuming a particular geometry for the Pt-CO complex. The surface area occupied by these Pt atoms can then be determined using a Pt cross-sectional area of .0841 nm² (4). The dispersion, defined as the ratio of the number of moles of CO adsorbed to the total number of moles of metal present in the catalyst, is then calculated. The results of these calculations are summarized in Table I. The catalyst with the highest CO chemisorption surface area is the 19% Pt/SnO₂. Such a result is contrary to that obtained from N₂ BET measurements as summarized in table II.

The effect of temperature upon the surface area and the dispersion is summarized for two of the catalysts in table III. Both catalysts seem to be relatively unaffected by temperature over this temperature range. There does seem to be a slight decrease in the surface area for the 2% catalyst, although the number of experiments are too limited for the results to have much significance.

O₂ Adsorption

O₂ adsorption is not observed to occur on the non-pretreated catalysts. When the catalyst is pretreated we obtain the adsorption curve shown in figure 9. This curve is identical in shape to that observed for the CO experiment except that the freestream composition does reach its original value. In addition, CO₂ was not observed even though the catalyst had been exposed to CO during the pretreatment process. The O₂ surface area and the resultant dispersion can then be calculated and are summarized for the two catalysts studied thus far in table IV. The results in table IV are calculated with the assumption that

the following reaction occurs



As a result each O_2 molecule occupies two sites on the surface.

The sample that had been given the normal pretreatment and then exposed to O_2 as discussed in the preceding paragraph was then used for a CO chemisorption experiment. Figure 10 shows the CO_2 production with this extensive history compared to the CO chemisorption studies of the same catalyst with no pretreatment. The CO_2 evolution is virtually the same in both cases. The chemisorption curve for both cases is shown in figure 11. The chemisorption/reaction process reaches a plateau after approximately the same number of pulses in each case. The pretreated-oxygen exposed catalyst does seem to have a higher initial activity than the sample with no pretreatment.

CO_2 Adsorption

Exposing the 1% CO_2 mixture to the 5% Pt non-pretreated catalyst results in apparent chemisorption as shown in figure 12. The apparent chemisorption is observed to be much larger when the catalyst is pretreated but does not exist for the 2% Pt catalyst as is also shown in figure 12. Closer examination of the chromatograms showed that, for the 5% mixture (an SiO_2 based catalyst), the CO_2 peaks had broadened, interfering with the Ne peaks used as an internal standard. As a result the amount of error in the CO_2 concentration calculation increased significantly. When the total mass of the catalyst is reduced this apparent chemisorption is seen to decrease significantly. The apparent chemisorption that we have observed is therefore a chromatographic effect due to the SiO_2 present in the catalyst. We conclude, therefore, that the catalyst samples do not chemisorb CO_2 from the freestream gas mixture.

DISCUSSION

Up to this point the numerical comparisons have been made with reference to the total mass of the catalyst. The actual catalytic material is the metal(Pt,Pd)/ SnO_2 with the SiO_2 present as a source of water to enhance catalyst longevity. To more accurately compare catalysts with and without SiO_2 the surface area has been calculated with respect to the amount of Pt/ SnO_2 present in the material. These calculations are summarized in table V. The surface areas of the two high metal load catalysts are now similar, indicating that the SiO_2 is serving primarily as a diluent and not interacting directly with the metal or the SnO_2 . However, the ratio of the CO surface area to the BET surface area for both SiO_2 containing catalysts is still quite low compared to the 2% Pt catalyst. This latter result is due, most likely, to differences in synthetic technique which would appear to allow more CO to bind to the surface of the 2% Pt catalyst than to any of the other catalysts in this study.

It is apparent that there can be experimental difficulties

due to the design of the system which places the catalyst immediately upstream of the GC column. Should the catalyst contain material which is also an effective chromatographic material, such as SiO_2 , peak resolution may be severely affected resulting in errors in the determination of concentration. We did not observe such an effect for either O_2 or CO but with CO_2 , band broadening became readily apparent. Indeed the CO_2 peak was observed to not return to baseline, overlapping severely with the Neon peak. The extent of the broadening could be affected by reducing the amount of material that is used and by the physical nature of the catalyst. The effect was not observed in the catalyst that did not contain SiO_2 . In the other non-pretreated catalyst the chromatographic effect was observed to disappear when the mass of the catalyst material was reduced. However, significant error still occurred when the SiO_2 containing catalyst underwent our standard pretreatment. The retention of CO_2 by the catalyst seems to be altered in some manner. What effect this has on catalyst activity and/or catalyst longevity is unknown at this time.

Another problem with the technique is the inability, in some of the samples, to attain the bypass value of the freestream composition after long exposure of the catalyst to the gas of interest. Since attaining the bypass value was not a problem when O_2 was the gas of interest or when CO was passed over a passive material such as SnO , it is thought that the non-attainment of the bypass value is due to some equilibrium process between the gas phase and the surface. A possibility would be the presence of physisorbed CO which, upon leaving the surface, creates a vacant site for gas phase adsorption. The time scale of this process could be such that the released CO is not observed on the chromatogram, possibly appearing on the wings of bands or as part of a weak broad background. Such an explanation would require that, for these sites, the adsorption process is much faster than the desorption process although desorption should be essentially finished in approximately 8 minutes, the time between pulses. Experiments are currently underway where the time between pulses is varied to evaluate whether or not such an equilibrium is of importance.

CO can chemisorb upon a surface in at least two different configurations, either linear or bridged(5). The surface area will then depend upon the geometry chosen for the chemisorbed species with the bridged configuration essentially occupying two sites with twice the coverage of the linear configuration. O_2 is assumed to dissociate upon contact with the surface resulting in two surface sites for each molecule of O_2 . If we assume that dissociation is occurring then the results of the O_2 experiments count the fraction of metal atoms exposed to the surface. If it is further assumed that these same atoms provide sites for CO adsorption then a comparison of O_2 chemisorption with CO chemisorption should provide an indication of the geometry of the CO chemisorbed species. The dispersion determined for 2% Pt/SnO_2 using oxygen, 0.076, compares quite favorably to that determined using CO if the linear geometry for the metal- CO complex is assumed. In contrast, the O_2 dispersion for the 5.8% $\text{Pt}/\text{SnO}_2/\text{SiO}_2$

catalyst, 0.044, is in good agreement with the CO dispersion if the bridged structure is assumed. Further work on these catalysts is in progress to determine if these apparent geometric differences depend on the presence of SiO₂ or upon the overall method of synthesizing the catalyst.

The difference for all the catalyst samples in the amount of CO chemisorbed for the pretreated and non-pretreated cases is quite large. This difference may be due in part to the presence of CO on the surface following pretreatment which would then block sites for further CO adsorption. We have not been able to observe the surface adsorbed CO spectrophotometrically with infrared spectra taken a few minutes after the pulsing of the sample is finished. Our preliminary interpretation is that the adsorbed CO will desorb particularly in the amount of time that it takes for the sample to cool from the 398 K pretreatment temperature. In addition we have already discussed the possibility that CO desorption is responsible for the concentration not reaching the bypass value for CO after a significant number of pulses. If CO is not present and blocking sites then there must be fewer sites available for adsorption after pretreatment than before pretreatment. An obvious conclusion is that there are fewer Pt atoms exposed to the surface, and that they have been covered by other atoms present in the sample. Hoflund et al (6) have observed this phenomenon in high vacuum work where they see the Sn atom becoming more dominant on the surface, effectively covering most of the Pt.

The interpretations discussed above are, of course, preliminary, with several experiments yet to be done. These include further O₂ adsorption work, and varying the time between the pulses to attempt to quantify whether or not desorption is affecting our surface area measurements. In addition, H₂ adsorption measurements must be performed to determine whether or not our conclusions about the geometry of the CO metal complex are correct.

REFERENCES

1. K. G. Brown et. al., in "Closed-Cycle, Frequency-Stable CO₂ Laser Technology" (C. E. Batten et. al. eds) NASA Conference Publication 2456, 1986 p. 219-226.
2. J. Freel, J. Catalysis, **25** 139-148 (1972).
3. J. Freel, J. Catalysis, **25** 149-160 (1972).
4. J. L. Lemaitre, P. G. Menon, and F. Delannay, in "Characterization of Heterogeneous Catalysts" (F. Delannay, ed.), Marcel Dekker, New York, U.S.A., 1984, p. 318.
5. N. V. Richardson and A. M. Bradshaw, Surface Sci. **88**, 255 (1979).
6. G. B. Hoflund, J. E. Drawdy, S. D. Gardner, M. R. Davidson, D. R. Schryer and B. T. Upchurch, This volume 1990.

TABLE I: Surface areas and dispersions determined by CO chemisorption at 303K. All calculated values refer to the linear form for the CO-metal complex.

| Catalyst | Pretreated? | Surface area (m ² /g) | Dispersion |
|--|-------------|-------------------------------------|----------------|
| 5.8%Pt/SnO ₂ /SiO ₂ 0.010 | No | 0.66 ± 0.18* | 0.044 ± |
| | Yes | 0.33 ± 0.05** | 0.022 ± 0.0035 |
| 2%Pt/SnO ₂ | No | 0.53 | 0.101 |
| | Yes | 0.36 | 0.069 |
| 19.5%Pt/SiO ₂ | No | 4.91 ± 1.04** | 0.097 ± 0.021 |
| | Yes | 3.37 | 0.0067 |
| 8.6%Pt, Pd/SnO ₂ /SiO ₂ | No | 2.08 ± 0.132# | 0.033 ± 0.002 |
| | Yes | 1.34 | 0.024 |

* Average of three measurements

** Average of four measurements

Average of two measurements

Table II: A comparison of BET and CO surface areas for non-pretreated catalysts. All surface areas in m²/g.

| CATALYST | BET | CO | CO/BET |
|---|-------|------|--------|
| 2% Pt/SnO ₂ | 6.8 | 0.53 | 0.078 |
| 5.8% Pt/SnO ₂ /SiO ₂ | 80.18 | 0.66 | 0.008 |
| 19.5% Pt/SnO ₂ | 100.0 | 4.91 | 0.049 |
| 8.6% Pt,Pd/SnO ₂ /SiO ₂ | 118.6 | 2.08 | 0.018 |

Table III: Temperature dependence of the surface area and dispersion for two of the catalysts.

| Temperature (K) | 2%Pt/SnO ₂ | | 5.8%Pt/SnO ₂ /SiO ₂ | |
|--------------------|-----------------------------|------------|---|------------|
| | Area (m ² /g) | Dispersion | Area (m ² /g) | Dispersion |
| 303 | 0.36 | 0.069 | 0.33 | 0.02 |
| 323 | 0.31 | 0.059 | 0.24 | 0.016 |
| 348 | 0.30 | 0.057 | 0.33 | 0.022 |

Table IV: Surface area and dispersions for O₂ chemisorption measurements at 303K.

| Pretreatment? | 2% Pt/SnO ₂ | | 5.8% Pt/SnO ₂ /SiO ₂ | |
|---------------|--------------------------|------------|--|------------|
| | Area (m ² /g) | Dispersion | Area (m ² /g) | Dispersion |
| No | 0.0 | 0.0 | 0.0 | 0.0 |
| Yes | 0.39 | 0.076 | 0.66 | 0.044 |

TABLE V: Surface areas and the ratio of surface areas based on the amount of Pt/SnO₂ present in the total sample.

| Catalyst | Pretreated? | Surface area (m ² /g) | CO/BET |
|---|-------------|----------------------------------|--------|
| 5.8%Pt/SnO ₂ /SiO ₂ | No | 1.44 | 0.018 |
| | Yes | 0.72 | |
| 2%Pt/SnO ₂ | No | 0.53 | 0.078 |
| | Yes | 0.36 | |
| 19.5%Pt/SiO ₂ | No | 4.91 | 0.049 |
| | Yes | 3.37 | |
| 8.6%Pt, Pd/SnO ₂ /SiO ₂ | No | 4.98 | 0.034 |
| | Yes | 2.57 | |

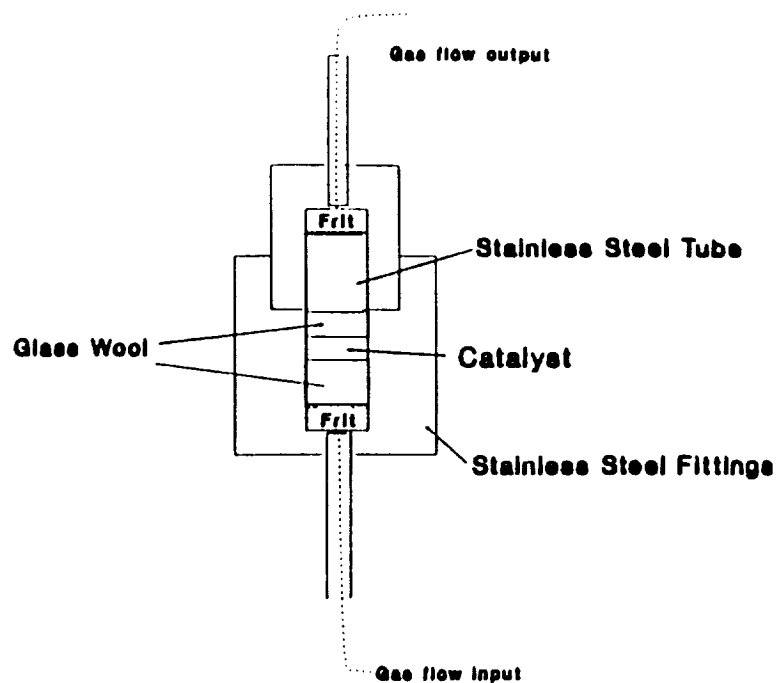

Figure 1: The sample holder for the catalyst.

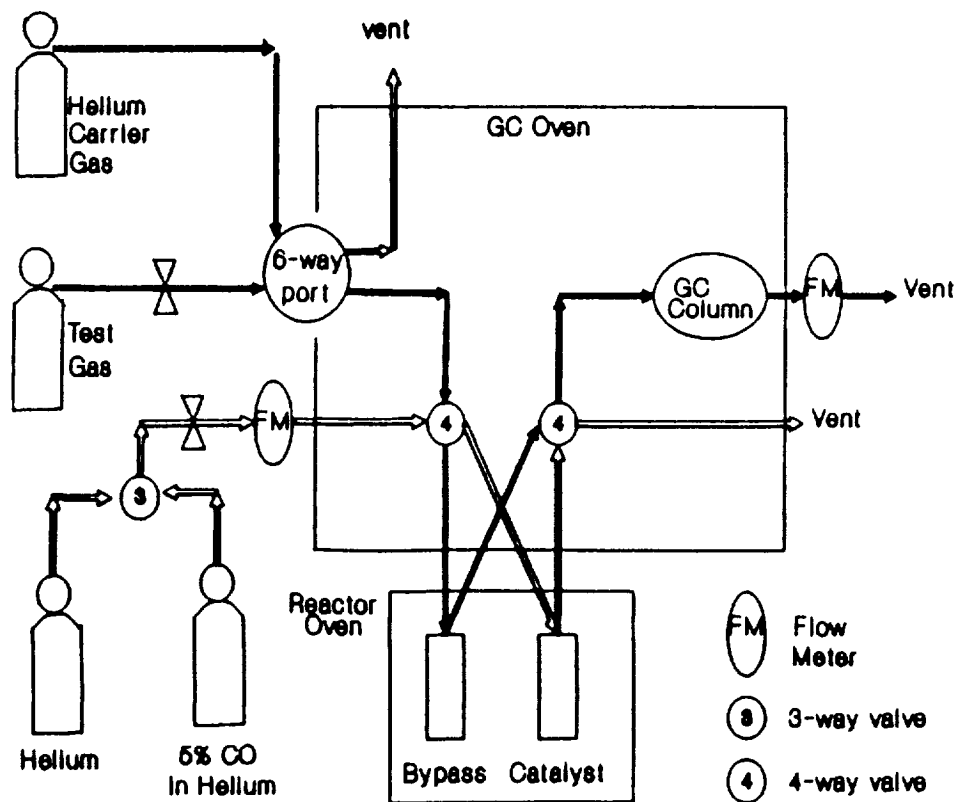

Figure 2: The flow diagram for the pulse reactor.

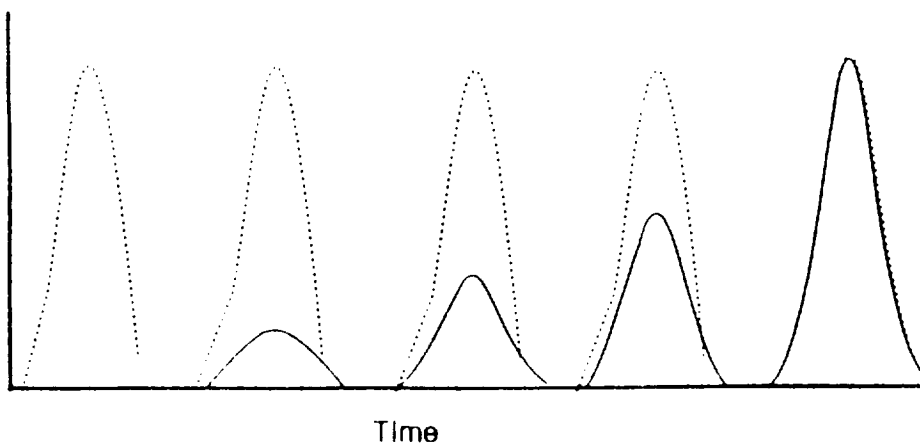

Figure 3: The dashed curves represent an observed GC peak with no catalyst present. The solid curves represent a model experiment with catalyst present. At the left complete adsorption of the gaseous material occurs while at the right the area again matches the original (bypass) area.

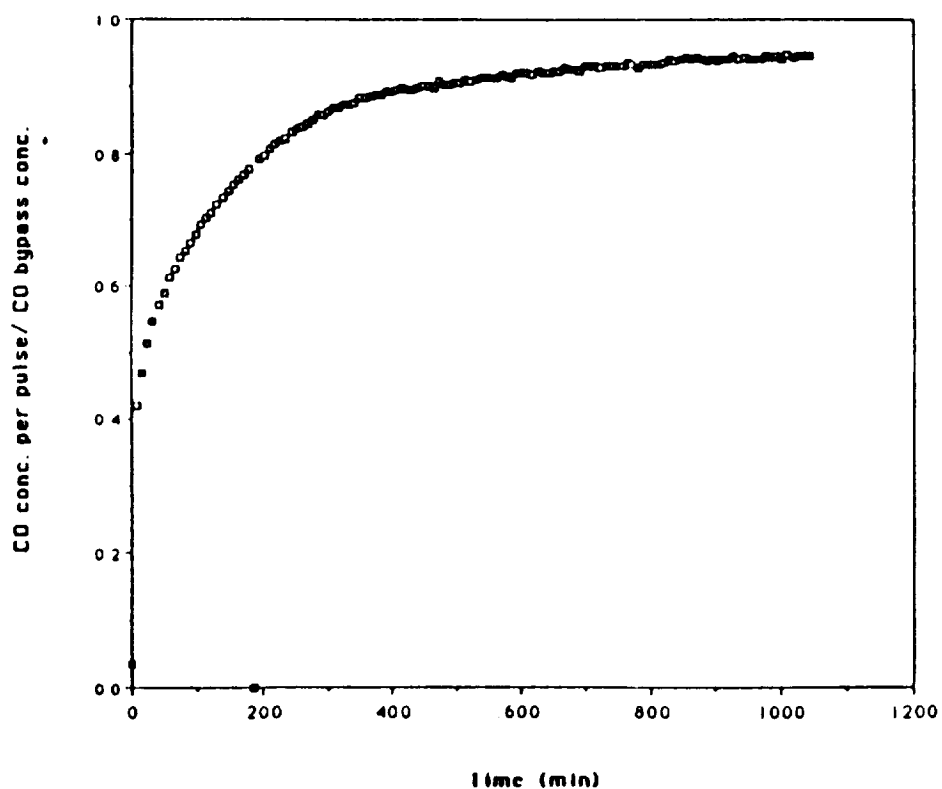

Figure 4: CO concentration as a function of time (number of pulses) for a non-pretreated 5.8% Pt/SnO₂/SiO₂ catalyst at 303 K using 1% CO, 2% Ne, balance He as the pulsing gas.

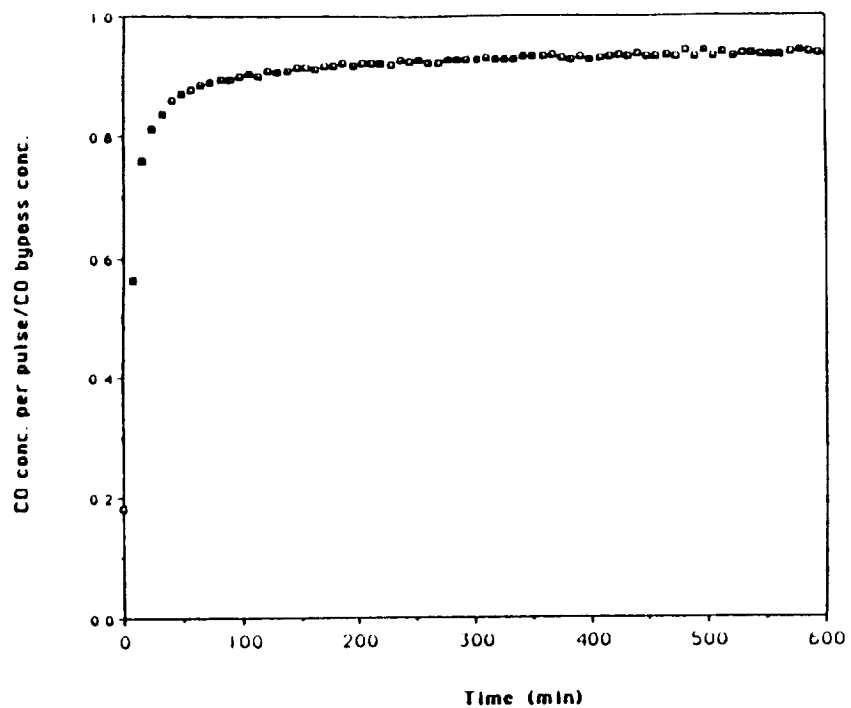

Figure 5: Same as figure 4 except the catalyst has been pretreated.

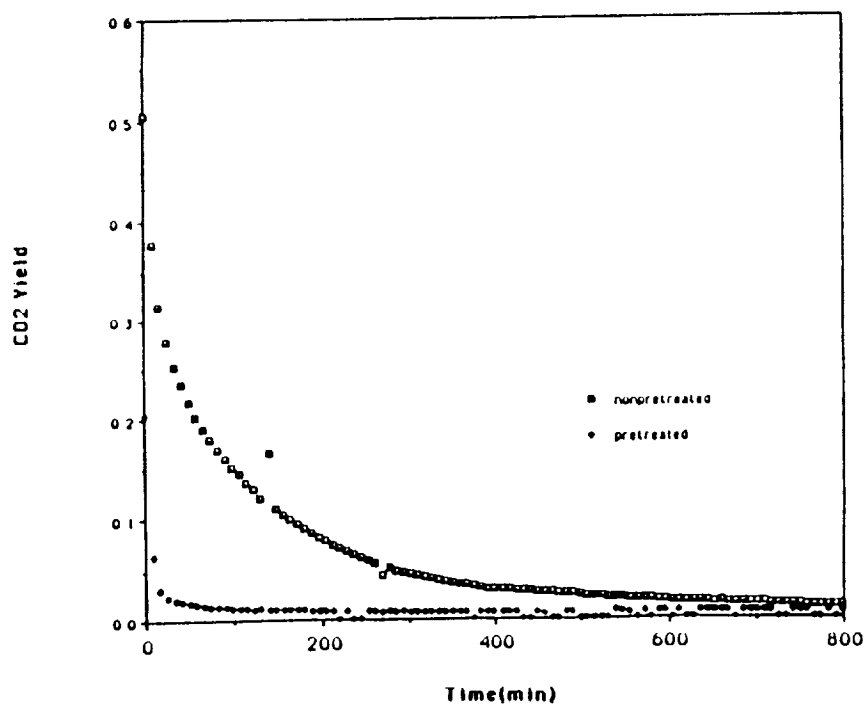

Figure 6: Carbon dioxide yield for the nonpretreated, \square , pretreated, \diamond . The sample is the same as that in figure 4 and 5.

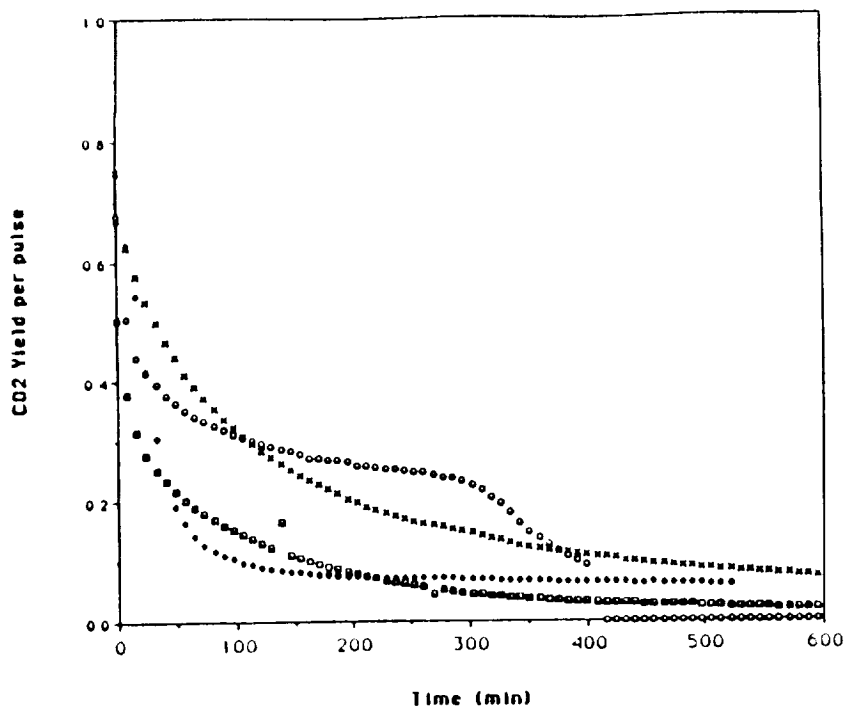

Figure 7: A summary of the CO₂ yields for the four non-pretreated catalysts at 303 K; ○ 19.5% Pt/SnO₂, × 8.6% Pt/8.6% Pd/SnO₂/SiO₂, □ 5.8%Pt/SnO₂/SiO₂, ♦ 2% Pt/SnO₂.

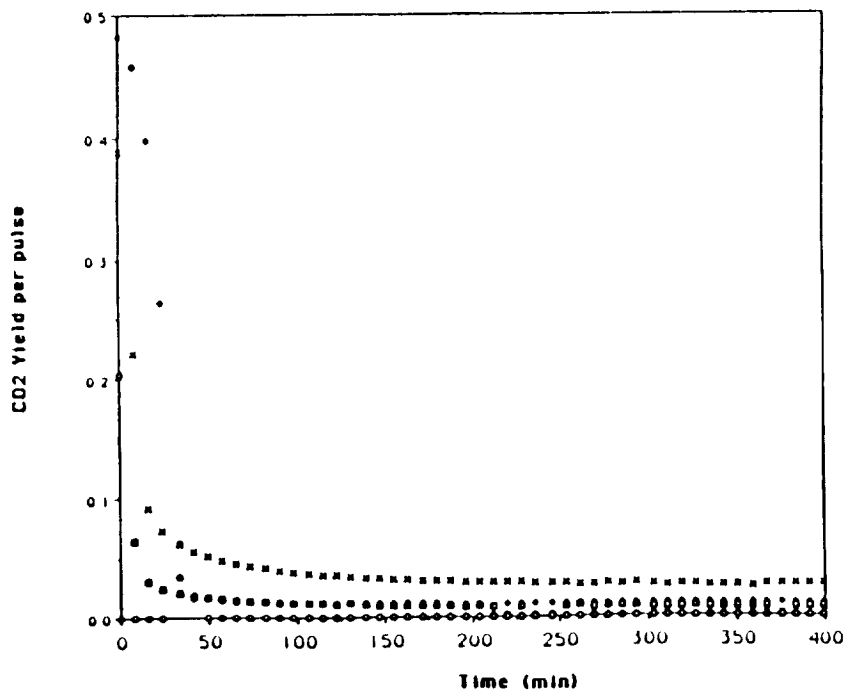

Figure 8: A summary of CO₂ yields for the four pretreated catalysts at 303 K. The symbols have the same meaning as in figure 7.

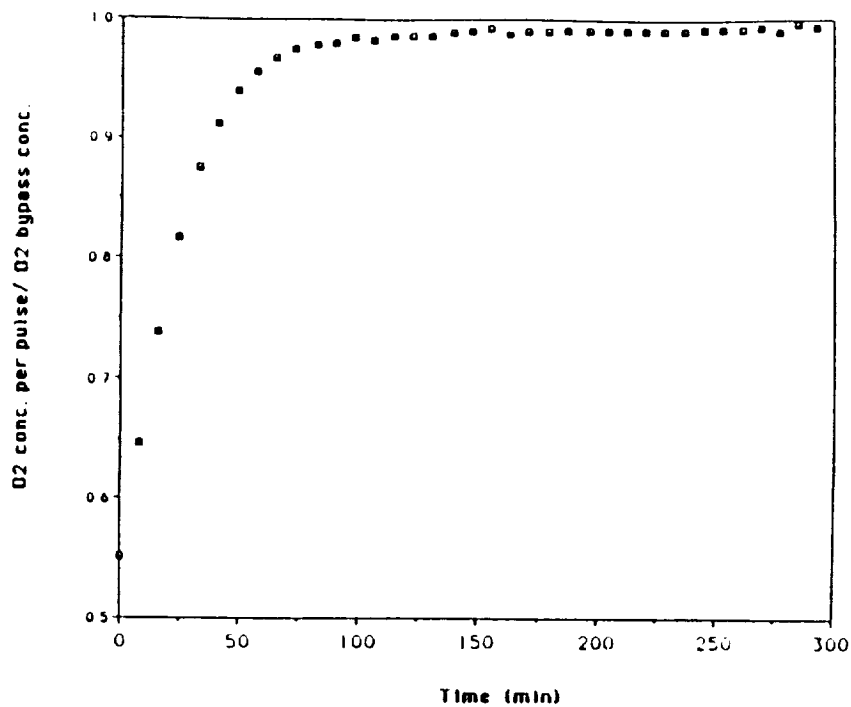

Figure 9: O₂ concentration as a function of time for the pretreated 5.8% Pt/SnO₂/SiO₂ catalyst at 303 K using 1% O₂, 2% Ne, balance He as the pulsing gas.

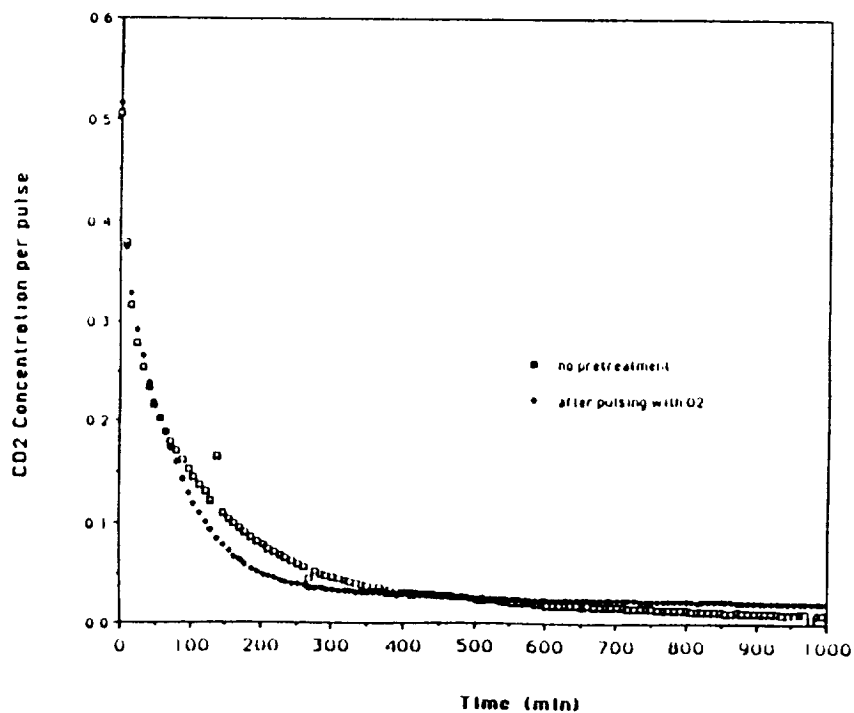

Figure 10: A comparison of CO₂ yields for the 5.8% Pt/SnO₂/SiO₂ catalyst with no pretreatment \square , and after the pretreated catalyst had been exposed to O₂ \blacklozenge .

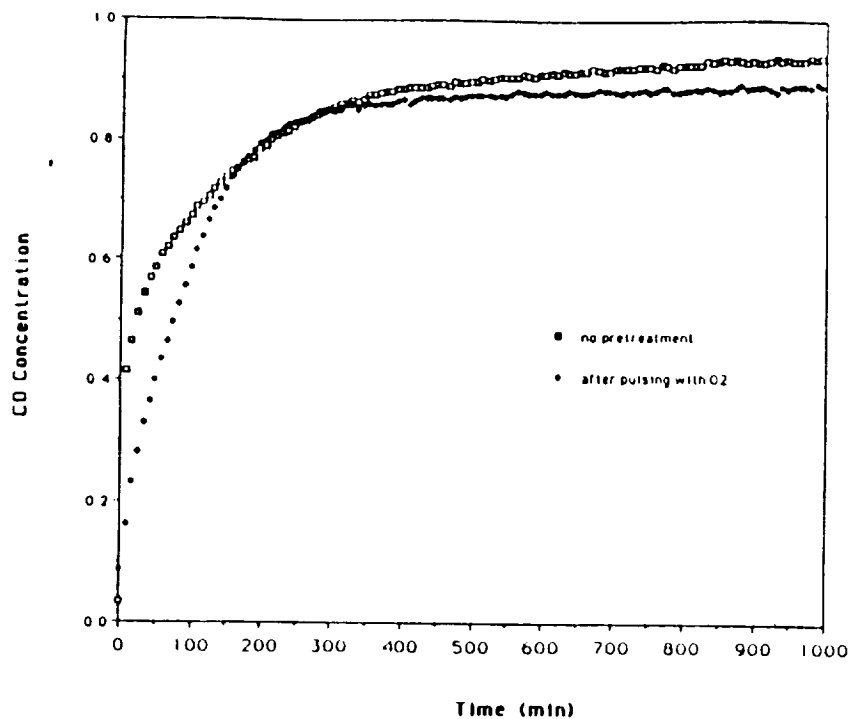

Figure 11: Change in CO concentration for the conditions described in figure 10.

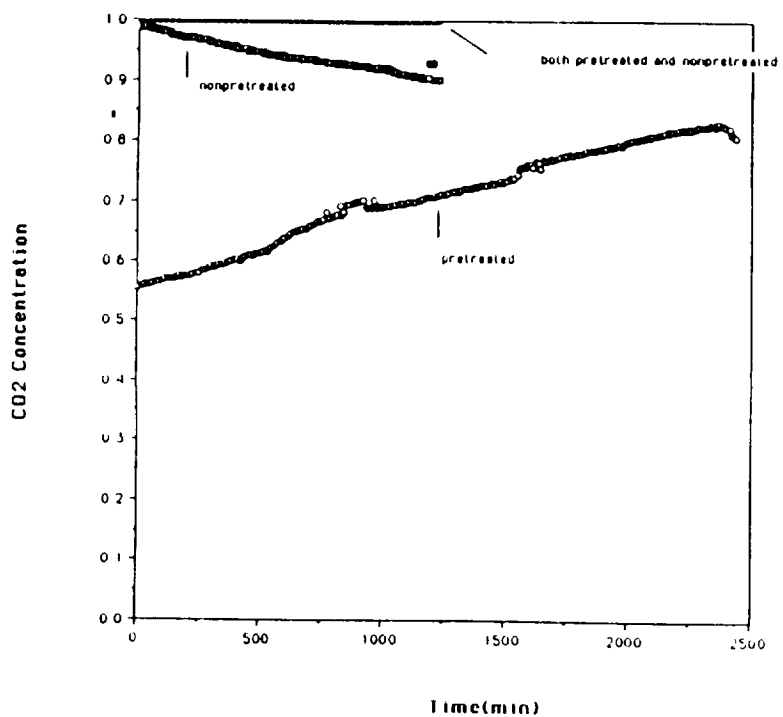

Figure 12: The effect of exposure of the catalyst to CO₂ with the indicated conditions. ♦ 2% Pt/SnO₂, □ and ○ 5.8% Pt/SnO₂/SiO₂.

SECTION IV

LASER STUDIES AND OTHER APPLICATIONS

