

N90-25063

## GENERATION OF CIRCUMFERENTIAL VELOCITY CONTOURS ASSOCIATED WITH PULSED POINT SUCTION ON A ROTATING DISK

by

Gregory V. Selby

Department of Mechanical Engineering and Mechanics  
Old Dominion University  
Norfolk, VA 23529-0247

Numerous experimental studies have been conducted on the steady, three-dimensional boundary layer over a disk rotating at constant angular speed in an otherwise undisturbed fluid. The subject flow geometry is of interest because it provides a relatively simple way to study the cross-flow instability phenomenon which occurs in three-dimensional boundary layers, as on swept wings. This flow instability results in the formation of a stationary spiral vortex flowfield over the disk, as shown by Wilkinson and Malik. Using a hot-wire probe, they mapped out the spatial wave pattern of stationary vortices, which filled the entire circumference of the disk. The subject flow instability caused transition-to-turbulent flow as the periphery of the disk was approached.

The effect on receptivity and transition of discrete disturbance modes, such as three-dimensional roughness elements and acoustic excitation, has been investigated. The present study--an extension of the work of Wilkinson and Malik--is focused on the effect of pulsed point suction on flow instability and transition, and, consequently, on the classical stationary vortical flow pattern.

The rotating-disk apparatus used in conducting the present experiment consisted of an optical-quality flat-glass disk (diameter = 33.0 cm, thickness = 2.8 cm), an air-bearing drive system and a two-axis traverse mechanism with a single-element hot-wire probe. Two diametrically opposed holes (for dynamic balance considerations) were located at a radius of 90 mm; however, only one ( $\theta = 0$  deg., see Fig. 1) was connected to the suction source--an acoustic horn driver. A fluid bath was used to seal the suction path in order to eliminate physical contact between the suction piping and the suction source. The disk/air-bearing drive system was mounted rigidly to the laboratory floor in order to eliminate mechanical vibration of the apparatus. A two-axis traverse mechanism was mounted on a horizontal rail located approximately one disk diameter above the disk. A single, linearized hot wire was used to measure velocity fluctuations in the disk boundary layer. The wire element was oriented parallel to the disk surface and aligned in the radial direction (at  $z = .86$  mm) to facilitate measurement of the circumferential component of velocity.

The present experiment involved operation of the disk at a constant rotational speed of 1193 rpm, with the initiation of the suction pulse (duration of 4 msec) and data acquisition via the hot-wire probe being triggered by a timing pulse from the rotating disk. This allowed synchronization of the suction pulse with the data acquisition period through appropriate delay times and provided for control of the angular region above the disk in which velocity data were acquired. A constant delay time of 43.2 msec between the timing pulse and the start of data acquisition insured that data were acquired over the same angular region above the disk in successive tests (between  $\theta = 54.6$  and 320.8 degrees; suction hole position between  $\phi = 215.4$  and 309.2 degrees). At a fixed

value of the radius, 125 time-dependent circumferential velocity measurements were made (beginning at  $\theta = 320.8$  deg.) at the rate of 0.3 msec per data point. These 125 measurements are defined as one data record.

The nominal delay time of 18 msec between the disk timing pulse and the initiation of the 4 msec suction pulse was incremented 79 times (each time by 0.3 msec) to provide suction pulse delay times between 18 and 41.7 msec. Thus, at a fixed location ( $r, \theta, z$ ) above the disk within the data acquisition region, 80 measurements of the time-dependent circumferential velocity were recorded, which represented the velocity at that point at 80 discrete times (between the initiation of the suction pulse and when the point in question was spatially coincident with the hot-wire element). The 80 values of velocity at the neighboring point (same  $r, z$ ; smaller  $\theta$ ) began and ended 0.3 msec later in time. In this manner, 80 data records were acquired at each of 70 values of the radius (between  $r = 90$  and 159 mm) providing a total of 700,000 measurements ( $125 \times 80 \times 70$ ) of velocity. These data were acquired by a PC-based data acquisition system, stored in data files, and transferred to a SUN computer system for processing.

Processing of the data involved development and execution of an algorithm which scanned each of the 80 data records (at each radius of interest) to identify and retrieve all velocity data corresponding to a specific elapsed time from the onset of the suction pulse and stored the data in a 80 by 70 array (assuming data at each of the 70 values of the radius were of interest). Three-dimensional graphs ( $u$  as a function of  $r$  and  $\theta$  at fixed  $z$  and elapsed time) were then constructed (see Fig. 2 for unsmoothed data plots) for specified values of the elapsed time using the PV-WAVE graphics software. Finally, a bicubic spline interpolation technique is to be applied to the data (after appropriate modifications--identified bicubic spline algorithms require rectangular data grids, as compared to the polar grid in the subject data set) in both the  $r$  and  $\theta$  directions in order to obtain smoothness in the data.

Sample unsmoothed circumferential velocity contours are presented in Figure 2 at fixed values of elapsed time (and  $z$ ). These contours show the outward (in  $r$ ) and circumferential (toward decreasing  $\theta$ ) convection of the wave packet formed as a result of the present boundary-layer perturbation.

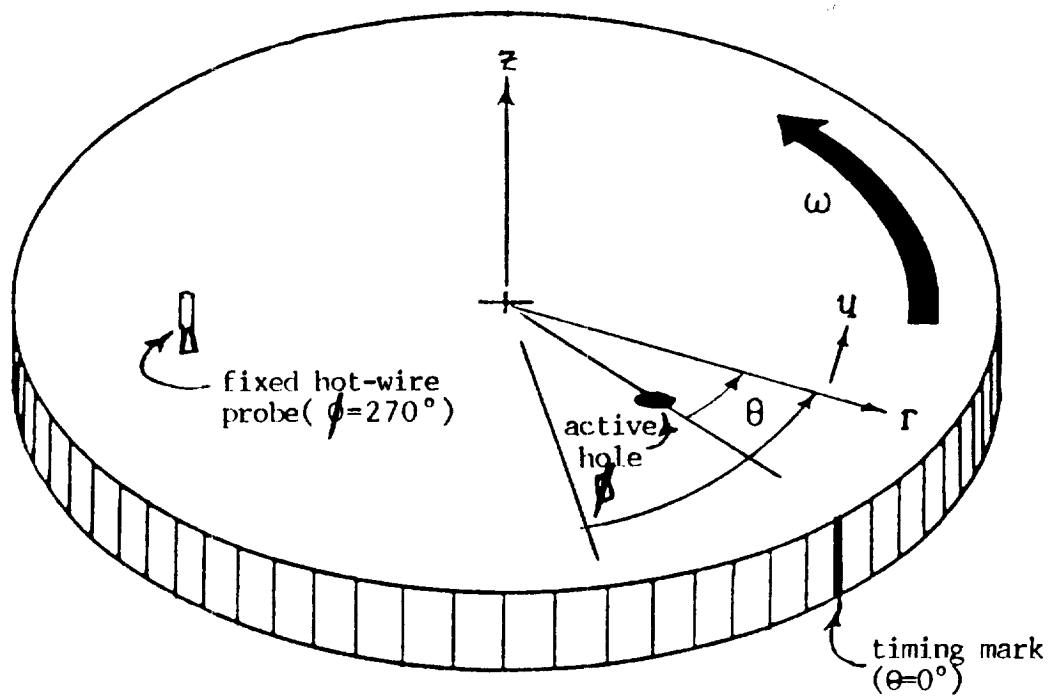
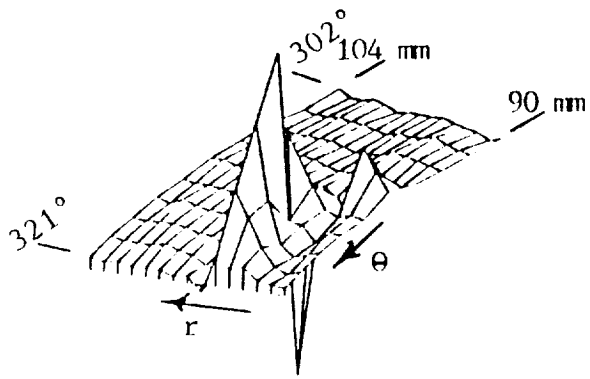
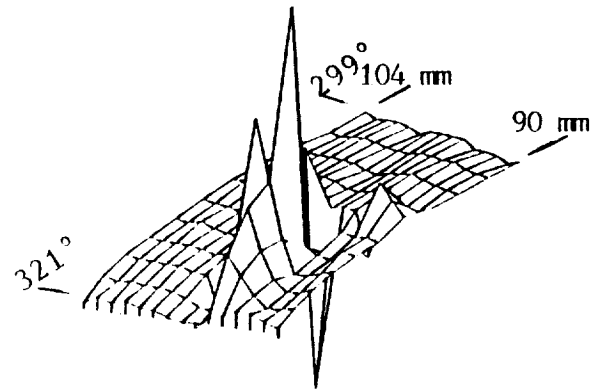

Figure 1. Rotating-Disk Coordinate Systems ( $\theta$  in rotating system;  $\phi$  in laboratory-fixed system)



a)  $t=4.2$  ms



b)  $t=4.5$  ms

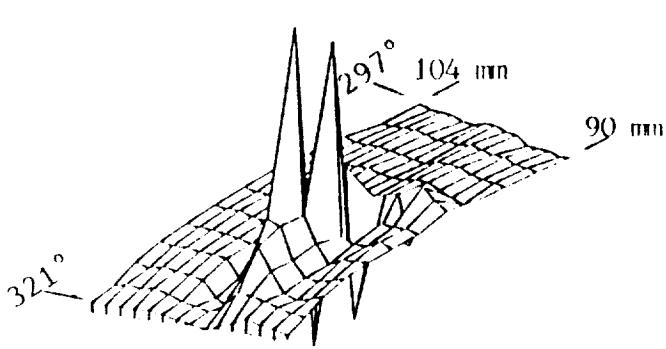

c)  $t=4.8$  ms

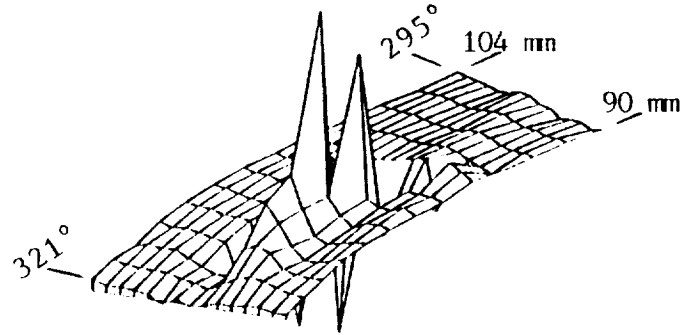

d)  $t=5.1$  ms

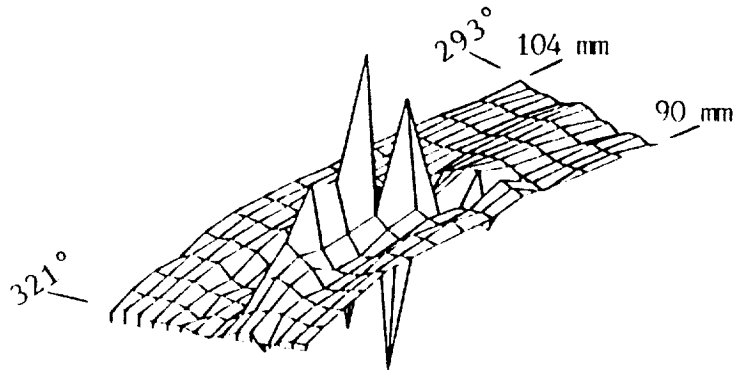

e)  $t=5.4$  ms

Figure 2. Circumferential Velocity Contours at  $Z=.86$  mm and Various Elapsed Times after Initiation of Suction (arbitrary vertical scale; active hole at  $\theta=0^\circ$ )