

NASA Technical Memorandum 102640

A NONCONTACTING MOTION MONITORING SYSTEM FOR AN ASTRONAUT TRANSLATION AID

TOM D. FINLEY

APRIL 1990

(NASA-TM-102640) A NONCONTACTING MOTION
MONITORING SYSTEM FOR AN ASTRONAUT
TRANSLATION AID (NASA) 13 p CSCL 14B

N90-25325

Unclass
63/35 0791074



National Aeronautics and
Space Administration

Langley Research Center
Hampton, Virginia 23665-5225



NASA Technical Memorandum 102640

A NONCONTACTING MOTION MONITORING SYSTEM
FOR AN ASTRONAUT TRANSLATION AID

Tom D. Finley

April 1990

Page 5 "Fixed Points for Weakly Commuting Mappings, Russell A. Dawkins, Fayetteville State University," was inadvertently printed in the report. Attached is a corrected copy of the report. Please destroy all copies of the report previously sent to you.

Issued June 1990

SUMMARY

A noncontacting motion sensing system has been developed that will monitor the motion of a cart along a track in the low-earth-orbit space environment. The system will be used on the Crew and Equipment Translation Aid (CETA) experiment scheduled for the STS37 flight in November 1990. It will allow the position, velocity, and acceleration of the cart to be determined as it moves along the track.

INTRODUCTION

This paper describes a noncontacting motion sensing system using a Hall effect probe. The system was developed to measure the velocity of a cart moving along a straight track on a Space Shuttle experiment. It will operate over a velocity range of zero to 6 feet per second over a -150°F to 100°F temperature range, and is insensitive to small transverse movements of the cart perpendicular to the primary motion axis. Position can be measured within 0.2" and velocity can be determined within $\pm 1.6\%$ at fixed locations along the track.

BACKGROUND AND REQUIREMENT

A means of moving personnel and equipment on the space station is being investigated on the CETA (Crew and Equipment Translation Aid) experiment scheduled for flight STS37. The experiment involves accelerating and decelerating a cart and its payload along a 50-foot track (fig. 1) to various speeds by different propulsive methods. Measurement of the cart's velocity is required in order to evaluate the different propulsion techniques. Since the cart does not remain in continuous contact with the track in the low gravity environment in orbit, a noncontacting type sensor is required in order to avoid influencing the results of the experiment. Moreover, the measuring system must be safe and must not interfere with other Shuttle systems.

An optional real-time velocity display would allow the astronaut to avoid speeds exceeding safety system design limits. System outputs must be compatible with the portable data acquisition package (PDAP) installed on the cart. The system must be unaffected by transverse off-axis motion (nominally, 1/8" in the vertical direction and 1/4" in the horizontal direction). A means of sensing the direction of the cart motion is desirable.

APPROACHES

Since accelerometers are being used to sense the instantaneous acceleration levels of the cart in three axes, the accelerometer outputs could be integrated to determine cart velocity. However,

velocity measurement accuracy is unacceptable because of data system and sensor errors. Data system error alone causes a 5-foot-per-second velocity error after 40 seconds.

An optical velocity sensing approach was considered in which a series of narrow, painted stripes on the track would be illuminated by a light-emitting diode and viewed by a phototransistor. A prototype system was tested but it was determined that optical adjustments would be very critical. The given variation in distance between the cart and the track would require a large depth of field in the optical system.

The measurement technique selected uses a Hall effect sensor mounted on the cart to sense magnets mounted in evenly-spaced locations along the track. Position information is recorded directly, and average velocity can be determined by measuring the time between consecutive magnets. The Hall effect sensor and the magnets are commercially available. The system requires almost no external circuitry and needs no adjustments.

DESIGN OF THE SYSTEM

The selection of magnets and Hall effect sensors and the precise position of the components require careful consideration. Magnets are available in many sizes and shapes, and the field to be sensed is affected by the type of magnet as well as the geometry. To minimize the space required for the magnets and to prevent interference with other devices on the Shuttle, very small, powerful magnets are used. A rare earth-type magnet was selected which is strong enough to activate Hall effect devices at close range but which has a low gauss level at larger distances from the magnet. The magnets selected are grade 22 commercially available units made of samarium cobalt. These disk magnets are 0.375" in diameter and 0.375" thick. (The field strength is about 8 gauss at a distance of 2 inches.) This reduces the chance of interaction with other onboard devices.

Various types of Hall effect sensors are available. Analog sensors provide an output that is a function of the gauss level. Digital sensors include internal electronics which produce either a high or low output depending on the gauss level. A unipolar-type digital device turns on at a certain gauss level and turns off below a lesser level. A bipolar-type digital device turns on at a certain gauss level and turns off when the magnetic field is reversed.

At high velocities, the short output pulse from the Hall probe may be missed by a sampling data acquisition system. To avoid this, the selected design employs a bipolar sensor with magnets positioned with alternating polarities. Movement along the track latches the sensor output on at a north pole magnet, off at the following south pole magnet, and so on. With this technique, the velocity can be very high with no chance of not sensing a magnet.

The system design employs two electronic Hall effect switches mounted on the cart (fig. 2). The spacing of the magnets is based on a tradeoff among the expected full-scale value of the velocity, the sampling rate of the data system, and the number of magnets which can be fitted to the track. For the CETA experiment, the maximum expected velocity is 6 feet per second, and the data sampling rate is 150 samples per second. The magnets fit inside a handrail. Twelve-inch spacing provides acceptable accuracy.

The second Hall effect switch is used in tandem to sense the direction of the cart motion. This is not essential to the CETA experiment but facilitates the data reduction without having to correlate the acquired data with the video images on tape. It also provides a redundant measurement which enhances the overall system reliability.

The optimum distance between the magnet and the Hall effect switch must be carefully determined considering the switch threshold over the anticipated temperature range, the gauss level of the magnets at various distances, and the anticipated movement of the switch perpendicular to the longitudinal track axis. Figure 3 shows the magnetic field of one of the selected magnets. Lines of constant gauss are plotted as a function of height above the magnet as well as distance off to the side. The magnets are right circular cylinders and the field strength plots are independent of the orientation around the cylindrical axis. The data in figures 2 and 3 can be combined to determine the operating range of these sensors when used with these magnets. Figure 4 shows the operational range of this system compared to the anticipated perpendicular movement of the CETA cart. This combination will allow for the nominal motion allowed plus approximately 0.2" margin for track misalignment or deflections due to load or temperature. The system must operate from -150°F to $+100^{\circ}\text{F}$. The Hall effect switches are calibrated over the entire temperature range. Figure 5 shows the gauss levels at which the sensors turn on and off as a function of temperature. The graph is a composite of the calibrations of six sensors and shows the highest and lowest levels of any of the tested sensors. Previous tests on another sample of five sensors showed that all would survive being dipped in liquid nitrogen and all were operational above -200°F .

SYSTEM ERRORS

The data system samples the Hall effect switches at a rate of 150 samples/second which results in a timing error up to 0.0067 second. The magnets are placed every 12.027 inches along the track. (This is at room temperature and chosen so that at the anticipated experiment temperature the spacing will be exactly 1 foot.) The position of the magnets as sensed by the Hall sensors was calibrated on the final assembly. The results of this static calibration are shown in fig. 6. The standard deviation of this

position error is 0.026 inches (0.0022 feet). The inflight position error is a function of the static error and a timing error because of the finite sampling rate of the data system. The probable error in timing is 0.0067 seconds divided by the square root of 12 or 0.0019 seconds. The standard deviation of the positional error in feet is:

$$\text{Error}_{\text{pos}} = \sqrt{(0.0022)^2 + (0.0019 * \text{speed})^2}$$

where speed is in feet per second. At the maximum expected speed of 6 fps, the error is .012 feet.

The velocity error in the system is also a function of the positional errors and the timing errors. Since the velocity determination is based on the difference between two time measurements the probable timing error is 0.0067 seconds divided by the square root of 6 or 0.0027 seconds. The standard deviation error in the velocity of the system (in %) is:

$$\text{Error}_{\text{vel}} = 100 * \sqrt{(0.0022)^2 + (0.0027 * \text{speed})^2}$$

where speed is in feet per second. At the maximum expected speed of 6 fps, the error is 1.6%.

The velocity error assumes that a one count error occurs because of the use of a sampling digital data system. This error can be reduced if the data is sensed on a filtered analog channel and the transition time is determined by interpolation. This requires knowledge of the filter characteristics and basically involves calculating backwards from the first data point after a transition to predict the time that the input to the filter switched. The PDAP system has filters and the data can be reduced using this option if the higher accuracy is desired.

CONCLUSION

A simple, reliable motion sensing system has been developed to provide position and velocity data for the cart used on the CETA experiment on the Space Shuttle. The system is noncontacting and does not interfere with the experiment. It works well over the anticipated temperature range and is not affected by the off-axis motion of the cart. The sensor is compatible with the onboard data system and provides data within acceptable accuracy limits.

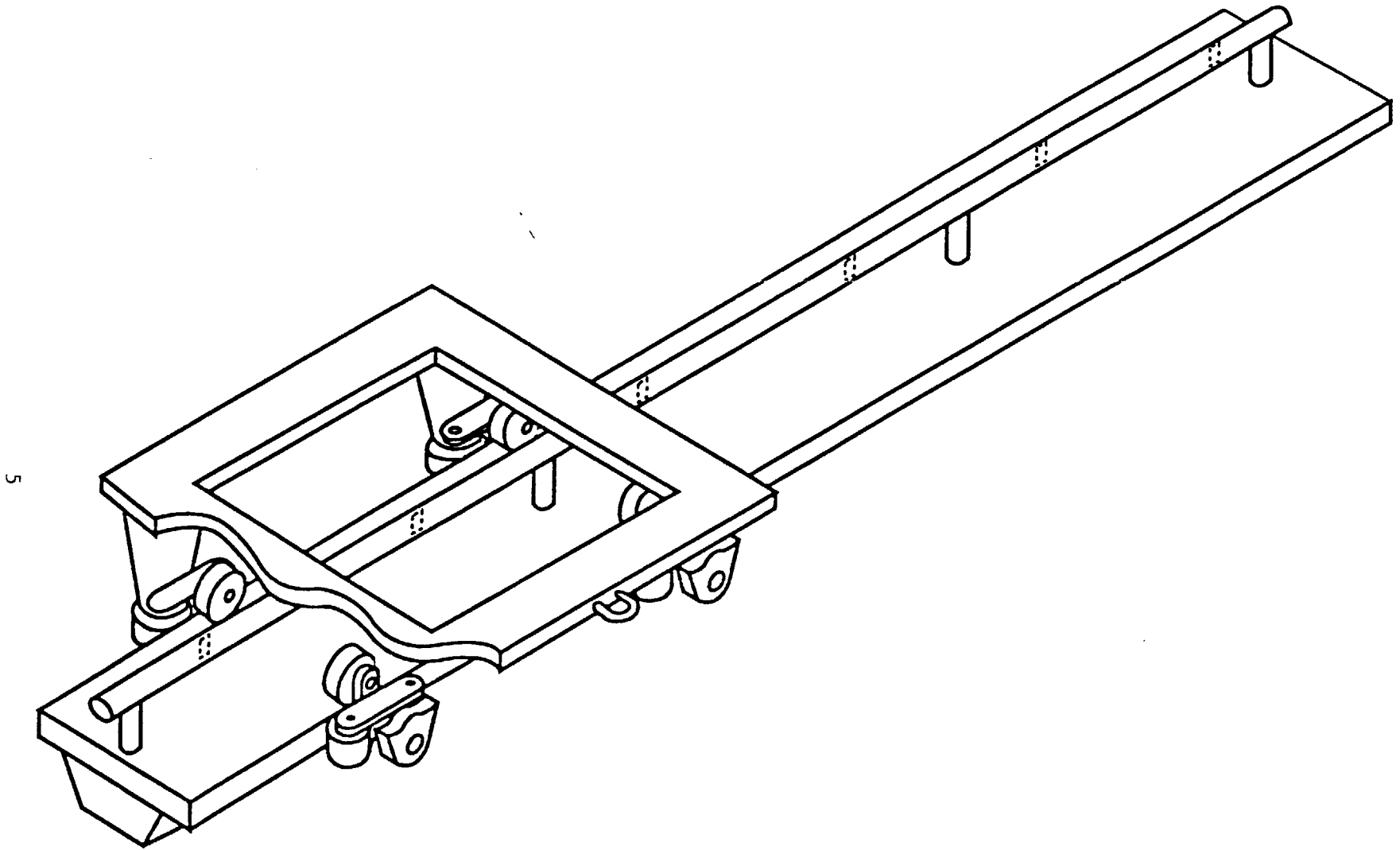

Figure 1. CETA experiment

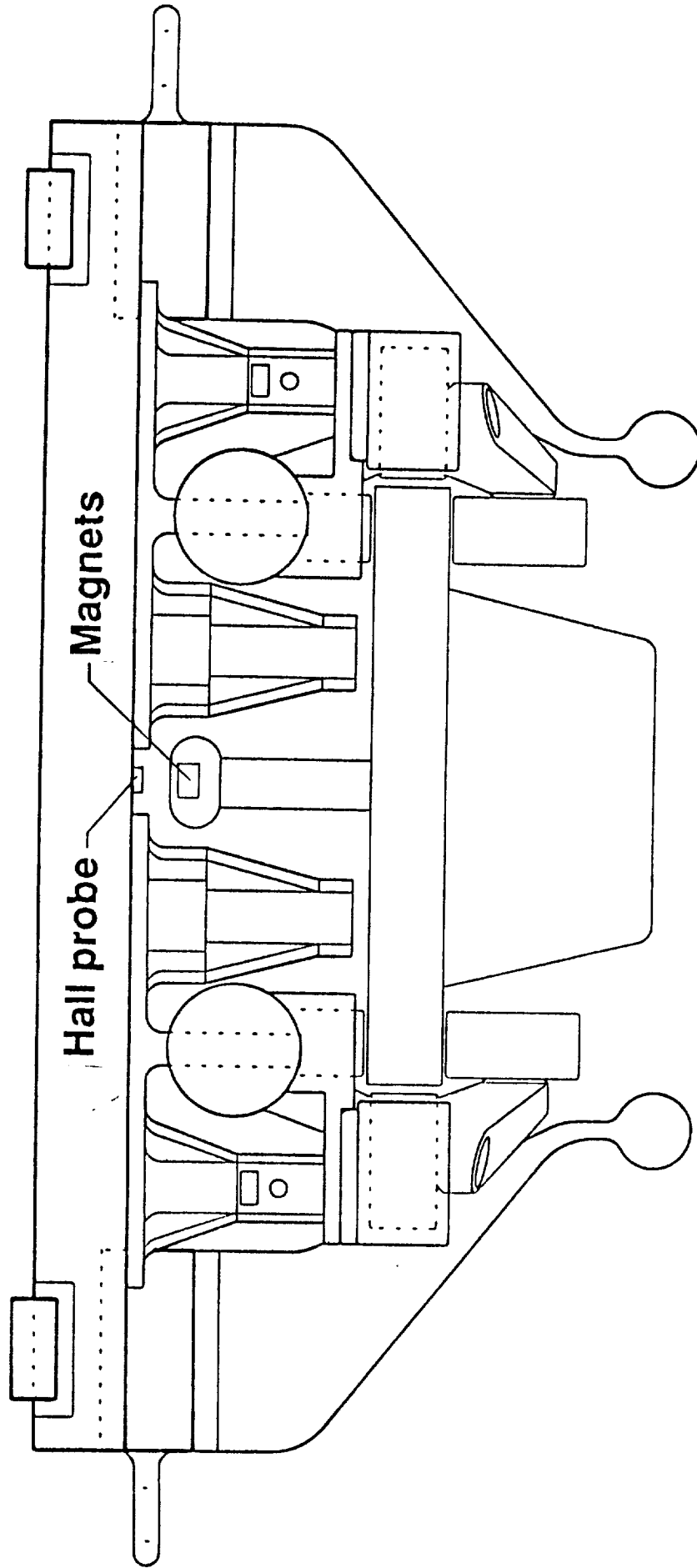

Figure 2. Magnet and hall probe locations for CETA

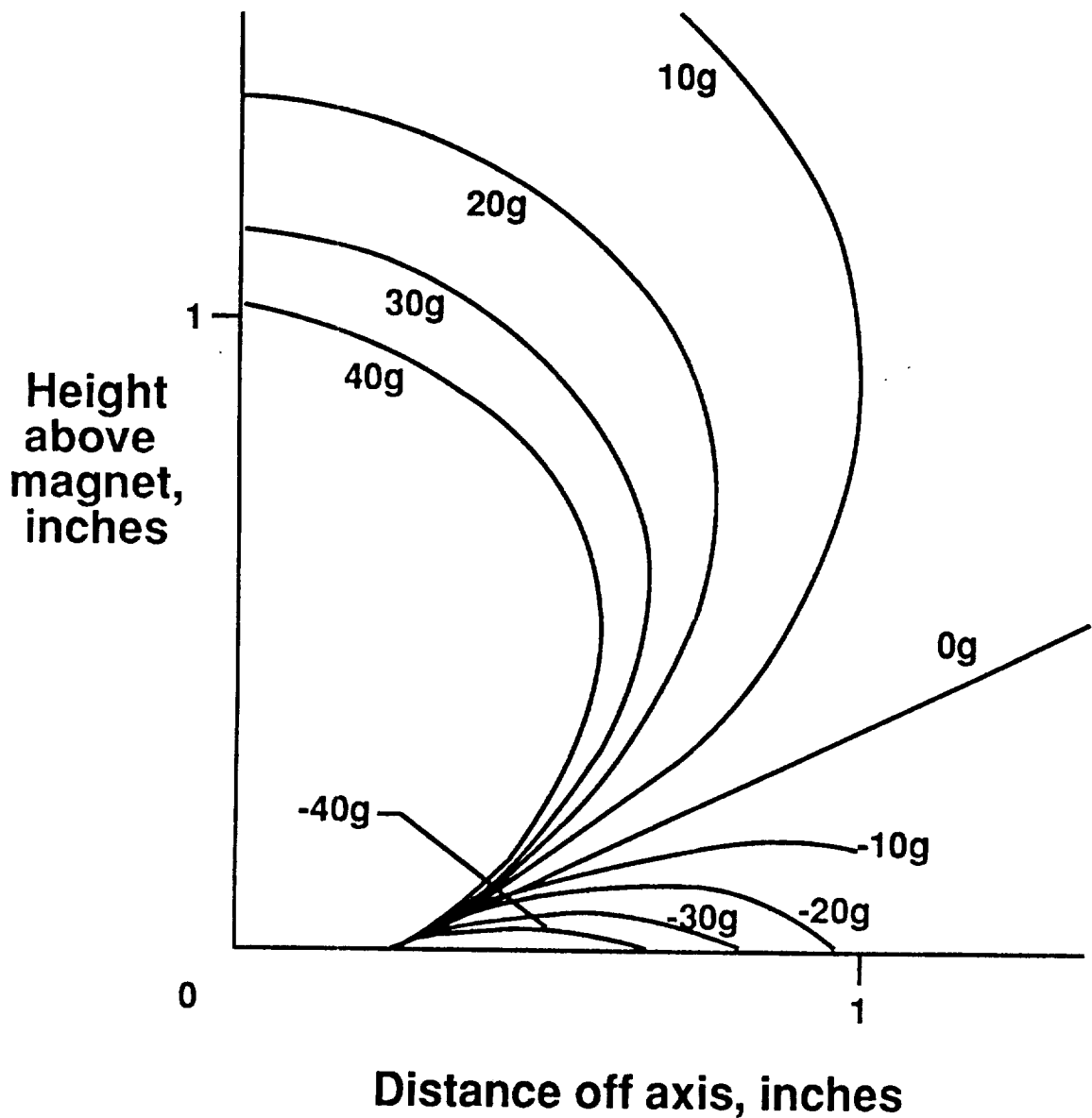

Figure 3. Magnet calibration

HALL PROBE VS TEMP

Microswitch SS81 CA

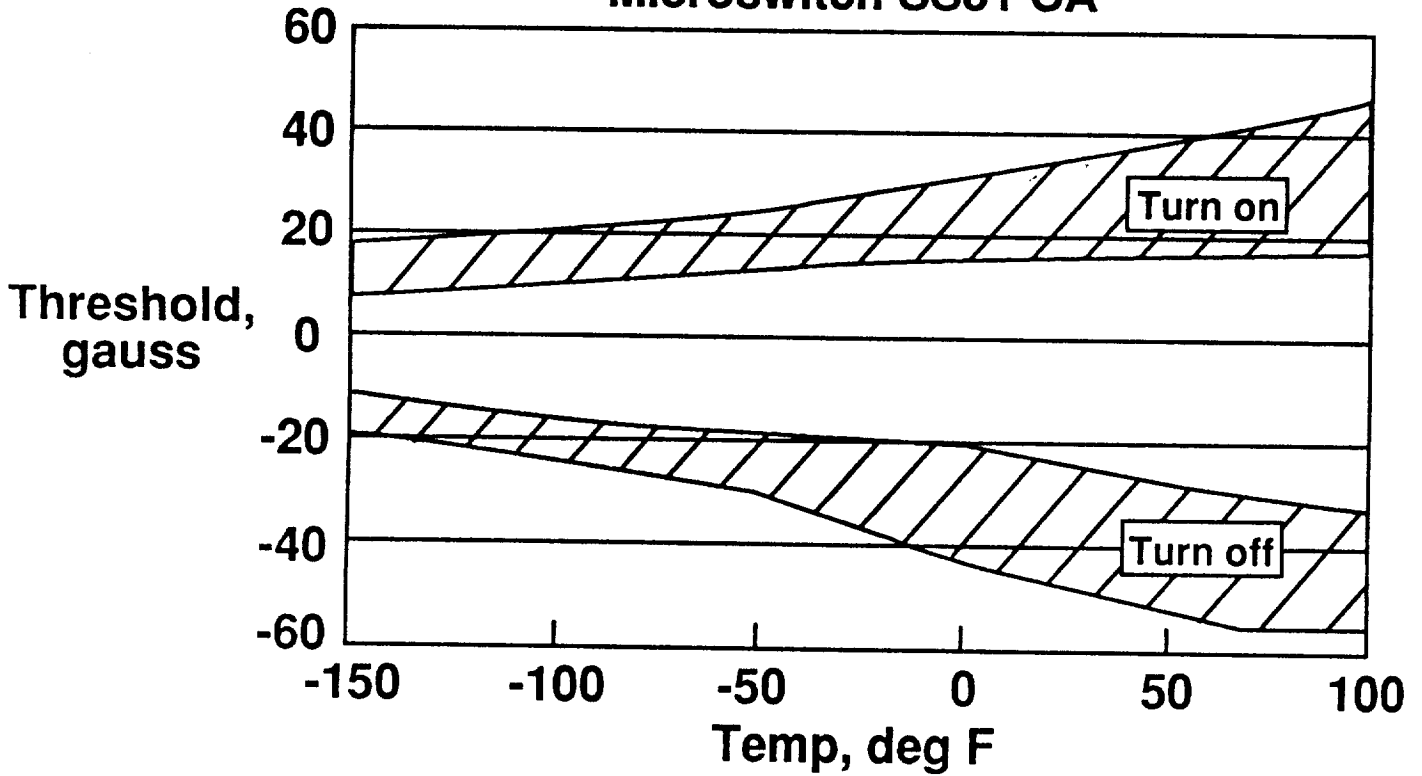

Figure 4. Calibration of 6 Hall sensors vs temperature

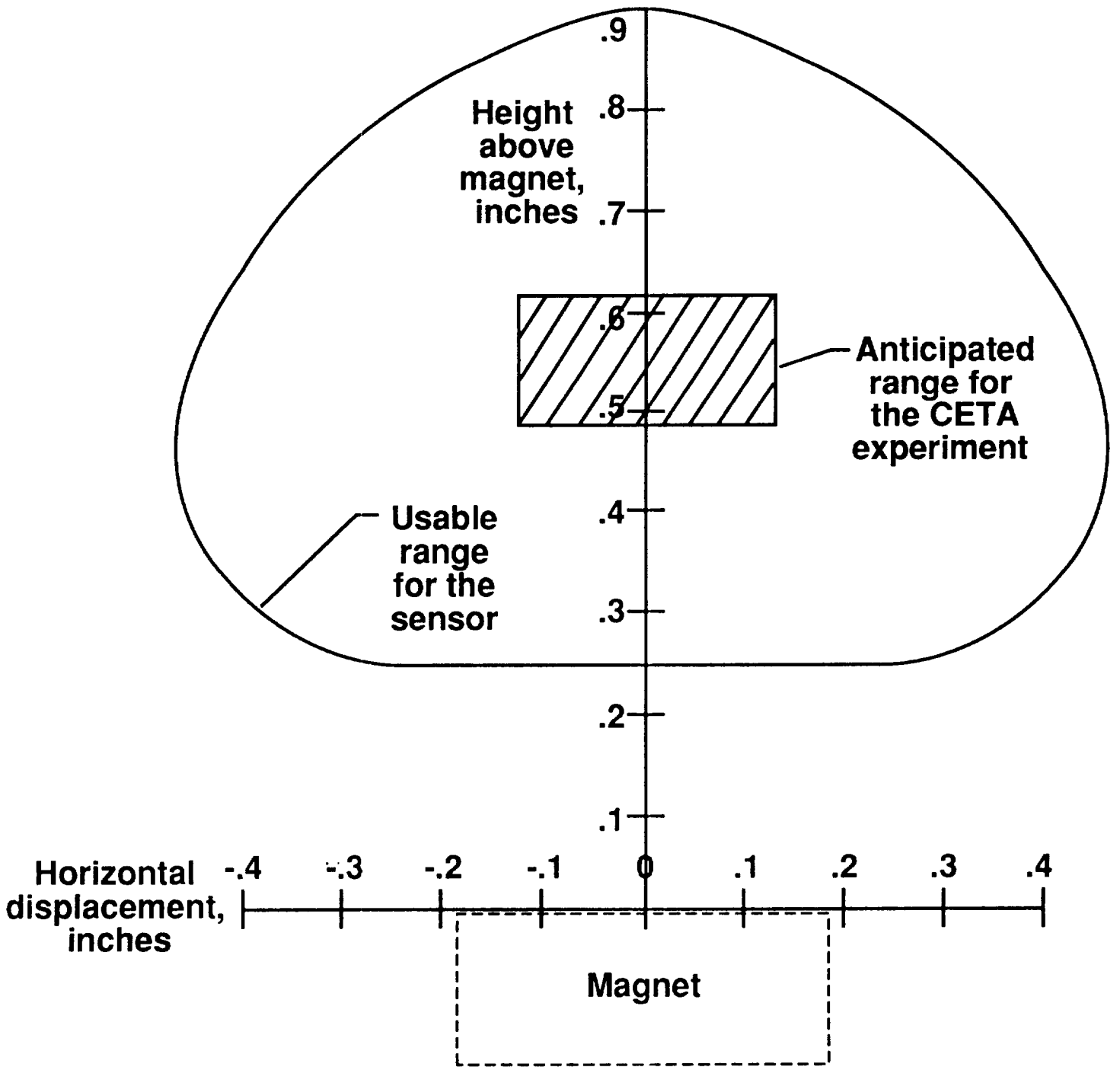

Figure 5. Measurement system operating limits

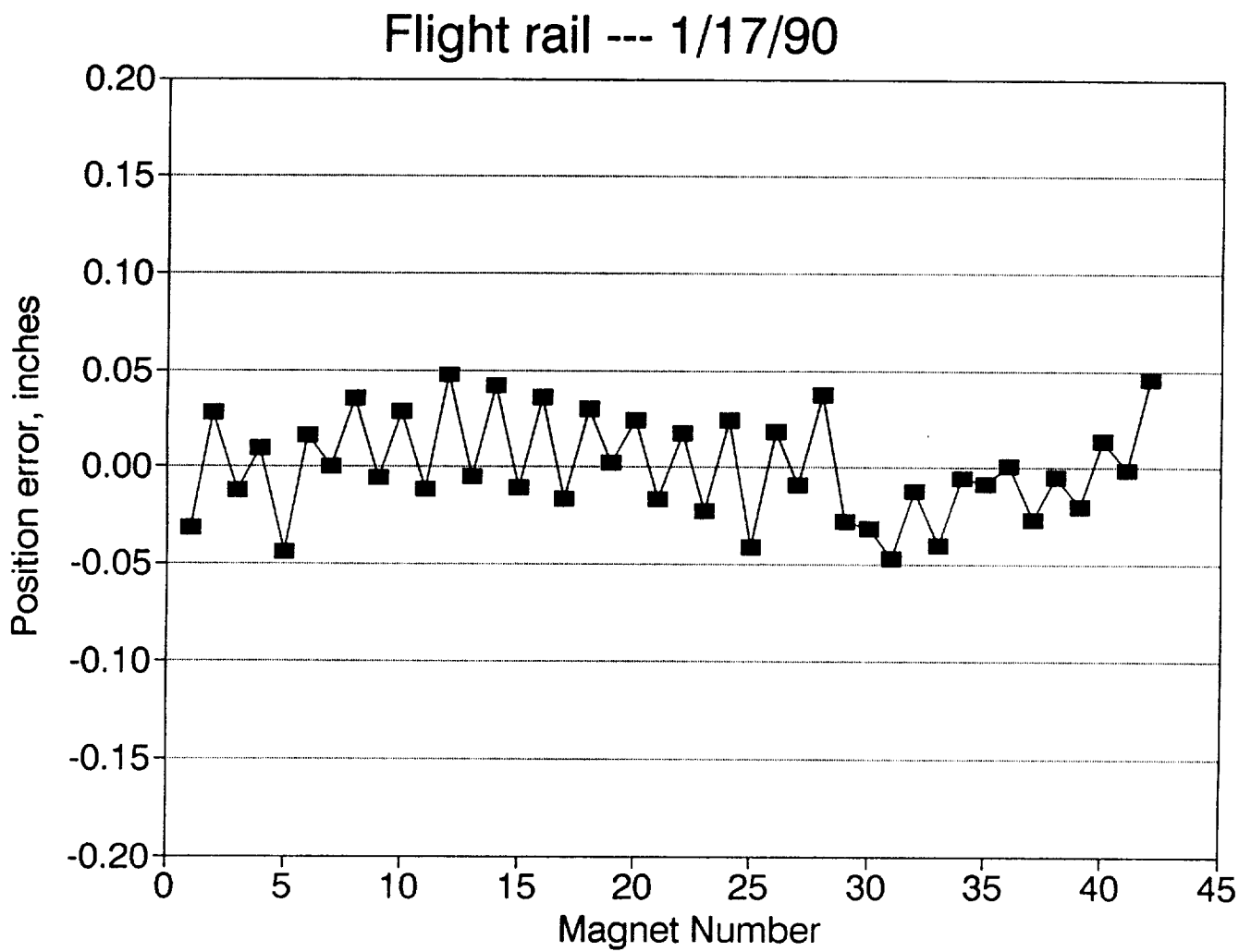

Figure 6. Rail calibration



Report Documentation Page

1. Report No. NASA TM-102640	2. Government Accession No.	3. Recipient's Catalog No.	
4. Title and Subtitle A Noncontacting Motion Monitoring System for an Astronaut Translation Aid		5. Report Date April 1990	6. Performing Organization Code
		8. Performing Organization Report No.	
7. Author(s) Tom D. Finley		10. Work Unit No. 472-47-12-50	
		11. Contract or Grant No.	
9. Performing Organization Name and Address NASA Langley Research Center Hampton, VA 23665-5225		13. Type of Report and Period Covered Technical Memorandum	
		14. Sponsoring Agency Code	
12. Sponsoring Agency Name and Address National Aeronautics and Space Administration Washington, DC 20546-0001			
15. Supplementary Notes			
16. Abstract <p>This paper describes the development of a noncontacting motion sensing system designed to monitor the movement of a cart along a track in the low-earth-orbit space environment. The system uses Hall effect sensors to detect the position of small permanent magnets located along the track. The measurement criteria are described, the system design is discussed, and estimates of the system error are given. The system will be used on the Crew and Equipment Translation Aid (CETA) experiment scheduled for the STS37 flight in November 1990. It will allow the position, velocity, and acceleration of the cart to be determined as it moves along the track.</p>			
17. Key Words (Suggested by Author(s)) velocity magnets Hall effect noncontacting motion sensing		18. Distribution Statement Unclassified-Unlimited Subject Category 35	
19. Security Classif. (of this report) Unclassified	20. Security Classif. (of this page) Unclassified	21. No. of pages 11	22. Price A03

