

NASA Technical Memorandum TM 102790

---

# Debris/Ice/TPS Assessment And Photographic Analysis For Shuttle Mission STS-31R

---

June 1990

(NASA-TM-102790) DEBRIS/ICE/TPS ASSESSMENT  
AND PHOTOGRAPHIC ANALYSIS FOR SHUTTLE  
MISSION STS-31R (NASA) 172 p CSCL 22B

N90-26040

Unclas

G3/16 0291557

**NASA**

National Aeronautics and  
Space Administration

---

# Debris/Ice/TPS Assessment And Photographic Analysis For Shuttle Mission STS-31R

---

Charles G. Stevenson  
NASA/Kennedy Space Center

Gregory N. Katnik  
NASA/Kennedy Space Center

Scott A. Higginbotham  
NASA/Kennedy Space Center

June 1990

---

National Aeronautics and  
Space Administration

**John F. Kennedy Space Center**



DEBRIS/ICE/TPS ASSESSMENT  
AND  
PHOTOGRAPHIC ANALYSIS  
OF  
SHUTTLE MISSION STS-31R

April 24, 1990

Prepared By:

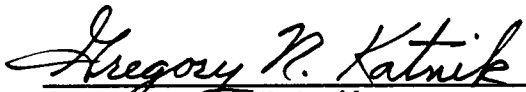
  
Gregory N. Katnik  
NASA/Kennedy Space Center  
TV-MSD-22

  
Scott A. Higginbotham  
NASA/Kennedy Space Center  
TV-MSD-22

Approved:  
June 25, 1990

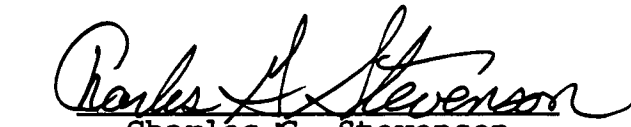
  
Charles G. Stevenson  
Lead, Ice/Debris Assessment Team  
Chief, ET Mechanical Systems  
TV-MSD-22

## TABLE OF CONTENTS

1.0	Summary . . . . .	2
2.0	KSC Ice/Frost/Debris Team Activities . .	5
3.0	Pre-Test Briefing . . . . .	10
3.1	Pre-Launch SSV/Pad Debris Inspection . .	11
4.0	Scrub . . . . .	15
4.1	Ice/Frost Inspection . . . . .	15
4.2	Orbiter . . . . .	15
4.3	Solid Rocket Boosters . . . . .	15
4.4	External Tank . . . . .	18
4.5	Facility . . . . .	22
4.6	Post Drain Inspection . . . . .	33
5.0	Launch . . . . .	37
5.1	Ice/Frost Inspection . . . . .	37
5.2	Orbiter . . . . .	37
5.3	Solid Rocket Boosters . . . . .	40
5.4	External Tank . . . . .	40
5.5	Facility . . . . .	44
6.0	Post Launch Pad Debris Inspection . . .	64
7.0	Film Review Summary/Problem Reports . .	68
7.1	Launch Film and Video Data Review . . .	75
7.2	On-Orbit Film Data Review . . . . .	106
7.3	Landing Film and Data Review . . . . .	106
8.0	SRB Post Flight/Retrieval Assessment . .	108
8.1	RH SRB Debris Inspection . . . . .	109
8.2	LH SRB Debris Inspection . . . . .	112
8.3	Recovered SRB Disassembly Findings . . .	116
9.0	Orbiter Post Landing Debris Assessment .	128
10.0	Debris Sample Lab Reports . . . . .	154
11.0	Post Launch Anomalies . . . . .	165
11.1	Post Launch Pad Inspection . . . . .	165
11.2	Film Review . . . . .	165
11.3	SRB Retrieval Inspection . . . . .	165
11.4	Orbiter Post landing . . . . .	166

## FORWARD

The Debris Team is continuing its effort to develop and implement measures to control damage from debris in the Shuttle operational environment and to make the control measures a part of routine processing and operations.

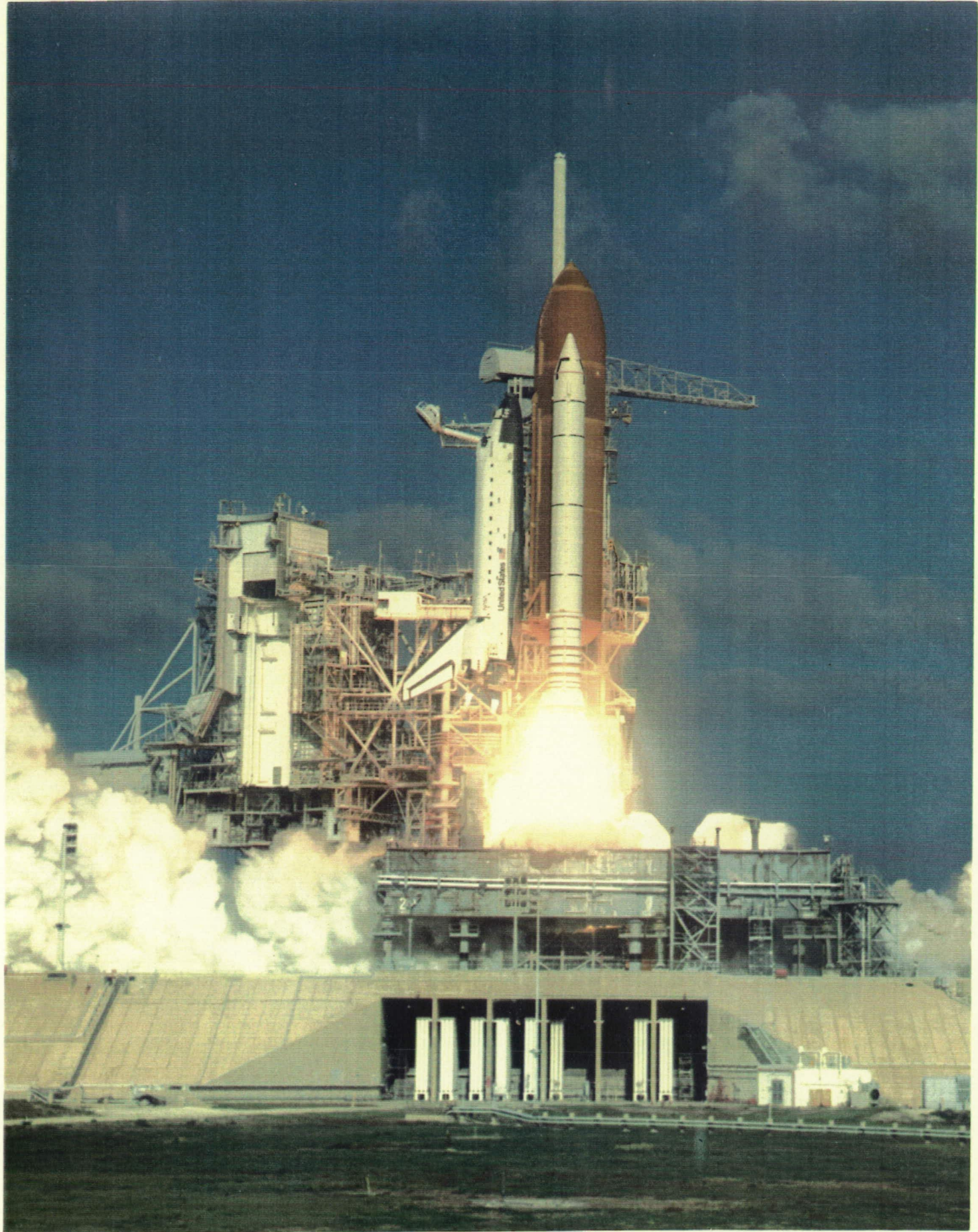

Shuttle Mission STS-31R was launched at 8:34 a.m. EST 4/24/90

## 1.0 Summary

Debris and Photo Analysis Team activities for Mission STS-31R began with the pre-launch debris inspection of the launch pad and Shuttle vehicle on 9 April 1990. No major anomalies were observed on OV-103 Discovery, BIO-37, or ET-34. Minor facility discrepancies, which included loose MLP deck bolts and loose debris items under the raised deck surrounding the SSME exhaust hole, were corrected prior to cryo loading the vehicle.

The first STS-31R Ice Inspection was performed on 10 April 1990. No Orbiter or SRB anomalies were detected. Very light condensate, but no ice or frost, was present on all acreage areas of the External Tank. There were no ET TPS anomalies. Eight Ice/Frost console anomalies were documented and found acceptable for launch per the LCC and NSTS-08303. The hydrogen umbilical leak sensor detected no significant hydrogen during the cryo load and was removed by the Ice Inspection Team during the T-3 hour hold.

The launch was scrubbed at T-4 minutes due to irregular speed indications on APU #1. A post drain inspection was performed five hours after the scrub decision. No ET TPS damage, such as divots or cracks on the tank acreage, were visible. There were no Orbiter or SRB TPS anomalies. Three Ice/Frost console anomalies were recorded during detanking and determined to be acceptable per NSTS-08303.

During the reinstallation of the hydrogen detection system tygon tubing for the second launch attempt, a 3-inch diameter foam repair in the LH2 tank aft dome apex was discovered to be missing. This condition was repaired per PR ET-34-TS-0044 prior to launch.

The pre-launch debris inspection of the pad and the Shuttle vehicle was performed again on 23 April 1990. No vehicle anomalies were observed. Minor facility discrepancies were dispositioned and corrected prior to vehicle loading.

The vehicle was cryo loaded for the second launch attempt beginning on 23 April 1990. No Orbiter or SRB anomalies were detected during the Ice Inspection. Light condensate, but no ice or frost, was present on most acreage areas of the External Tank. Normal amounts of hard ice were present in the LO2 feed-line bellows and support brackets. Light accumulations of frost on the LO2 ET/Orbiter umbilical were typical. The top and sides of the LH2 ET/Orbiter umbilical were covered by the usual quantities of ice/frost. Ten Ice/Frost console anomalies were documented during the countdown. Nine were found acceptable for launch per the LCC and NSTS-08303. The tenth anomaly (Anomaly 002) documented ice/frost accumulations and vapors in the area of the LH2 umbilical flapper valve actuator torque tool port closeout. This closeout consists of a PDL foam plug sealed with epoxy-resin. A crack in the MBO-130-136 polyurethane resin

sealant on the upper outboard corner of this closeout allowed cold helium purge gas to escape. IPR 31RV-0180 was taken on this anomaly. The IPR was upgraded to PR ET-34-TS-0045 and dispositioned with MRB approval to use-as-is. Since this area was not one of the LCC or NSTS-08303 ice acceptance areas, LCC waiver LW021 was required (ref PRCB 570957L). Aside from this anomaly, the ET ice condition was well within the data base for ice formation at the time of launch.

A post launch debris inspection of Pad 39B was performed after launch. No flight hardware or TPS material was found. The doghouse blast covers on holddown posts #4 and #8 exhibited minor erosion. Otherwise, launch damage to the holddown posts was minimal. No signs indicative of stud hang-up were visible. No fragments from HDP debris containers were found. The facility GH2 vent line had latched properly and had no loose cables. Overall, the facility sustained minimal damage.

A total of 116 film and video items were analyzed as part of the post launch data review. No facility anomalies, major vehicle damage, or lost flight hardware was observed that would have affected the success of the mission. A 1/2" x 3-1/2" piece of frangible nut web fell from the SRB aft skirt HDP #1 stud hole at liftoff. No debris fell from HDP #2 through #8. There were no signs indicative of a HDP stud hang-up in any of the films. A small tile chip (originally reported by JSC to be an entire tile) fell from the aft trailing edge of the RH rudder speed brake at SSME start. Numerous pieces of debris fell from the vehicle during ascent. Most have been identified as ice/frost particles from the ET/Orbiter umbilicals, RCS paper covers, instafoam particles from the SRB aft skirts, and SRB propellant slag. After roll program, two different films detected sun reflections off the RH inboard elevon trailing edge inboard corner and later off the orbiter windows.

The post flight inspection of Solid Rocket Boosters was conducted at Hanger AF on 26 April 1990. Both frustums exhibited a total of 12 TPS debonds with no loss of material. No TPS was debonded or lost on either forward skirt. Both forward skirt-to-frustum severance rings had been removed before a detailed assessment was performed on the safety wired pins. The phenolic plate on the -Z RH RSS antenna exhibited minor delamination. Three small (0.70 to 1.20 inch long) cracks were present in field joint cork closeouts on the LH SRB. K5NA was missing from aft-facing bolt heads on both kick rings and from around all aft BSM nozzles. The Debris Containment System (DCS) plungers on HDP #2 through #8 were properly seated and latched, but a frangible nut fragment prevented the plunger on HDP #1 from seating. The entire LH IEA was structurally torn from the SRB by water impact and was found hanging by its electrical cables.



A post landing inspection of OV-103 was performed on 29 & 30 April 1990 on EAFB Runway 22 and in the ADFRF MDD. The Orbiter TPS sustained a total of 63 hits, of which 14 had a major dimension of one inch or greater. The Orbiter lower surface had a total of 47 hits, of which 13 had a major dimension of one inch or greater. Based on these numbers and comparison to statistics from previous missions of similar configuration, the number of hits on the lower surface is less than average. Also, based on the severity of damage as indicated by surface area and depth, this flight is better than average. The distribution of damage sites on the Orbiter does not point to a single source for ascent debris, but rather to a shedding of ice/frost and TPS debris from random sources.

White streaks/deposits were present on both wing leading edge RCC panels. Lab analysis revealed the streaks were caused by TPS materials, SRB separation products, and landing site earth minerals. The lower surface Orbiter tile samples indicated localized heating from re-entry, but the only materials recovered from the damage sites were tile TPS elements, paint, and landing site products. The Orbiter window sampling provided results that indicate exposure to SRB/BSM exhaust residue, TPS materials, and landing site products. Material taken from the ET/ORB umbilicals turned out to be TPS closeout materials.

Since the debris sample lab reports indicated sample contamination due to sampling techniques, a Landing/Retrieval sample kit will be created. This kit will be coordinated with laboratory personnel and contain tooling and containment items to eliminate the non-standard sampling techniques, and reduce the sample contamination.

A total of 11 Post Launch Anomalies were observed during this mission assessment.

## 2.0 KSC ICE/FROST/DEBRIS TEAM ACTIVITIES

Team Composition: NASA KSC, NASA MSFC, NASA JSC,  
LSOC SPC, RI - DOWNEY, MMMSS - MAF,  
USBI - BPC, MTI - UTAH

### Team Activities:

#### 1) Prelaunch Pad Debris Inspection

Objective: Identify and evaluate potential debris material/sources. Baseline debris and debris sources existing from previous launches.

Areas: MLP deck, ORB and SRB flame exhaust holes, FSS, Shuttle vehicle external surfaces

Time: L - 1 day

Requirements: OMRSD S00U00.030 - An engineering debris inspection team shall inspect the shuttle and launch pad to identify and resolve potential debris sources. The prelaunch vehicle/pad configuration shall be documented/photographed.

Documents: OMI S6444

Report: Generate PR's and recommend corrective actions to pad managers.

#### 2) Launch Countdown Firing Room 2

Objective: Evaluate ice/frost accumulation on the vehicle and/or any observed debris utilizing OTV cameras.

Areas: MLP deck, FSS, Shuttle vehicle external surfaces

Time: T - 6 hours to Launch + 1 hour or propellant drainback

Requirements: OMRSD S00FB0.005 - Monitor and video tape record ET TPS surfaces during loading through prepressurization.

Documents: OMI S0007, OMI S6444

Report: OIS call to NTD, Launch Director, and Shuttle managers. Generate IPR's.

### 3) Ice/Frost TPS and Debris Inspection

**Objective:** Evaluate any ice formation as potential debris material. Identify and evaluate any ORB, ET, or SRB TPS anomaly which may be a debris source or safety of flight concern. Identify and evaluate any other possible facility or vehicle anomaly.

**Areas:** MLP deck, FSS, Shuttle vehicle external surfaces

**Time:** T - 3 hours (during 2 hour BIH)

**Requirements:** OMRSD S00U00.020 - An engineering debris inspection team shall inspect the shuttle for ice/frost, TPS, and debris anomalies after cryo propellant loading. Evaluate, document, and photograph all anomalies. During the shuttle walkdown, externally inspect orbiter aft engine compartment for water condensation and/or ice formation in or between aft compartment tiles. An IR scan is required during the shuttle inspection to verify ET surface temperatures. During shuttle walkdown, inspect ET TPS areas which cannot be observed by the OTV system.

**Documents:** OMI S0007, OMI S6444

**Report:** Briefing to NTD, Launch Director, Shuttle management; generate IPR's.

### 4) Post Launch Pad Debris Inspection

**Objectives:** Locate and identify debris that could have damaged the vehicle during launch

**Areas:** MLP deck, FSS, pad apron and slopes, flame exhaust holes and trenches, extension of trenches to perimeter fence, walkdown of the beach from Playalinda to Complex 40, aerial over flight of inaccessible areas.

**Time:** Launch + 3 hours (after pad safing, before washdown)

**Requirements:** OMRSD S00U00.010 - An engineering debris inspection team shall perform a post launch pad/area inspection to identify any lost flight or ground systems hardware and resultant debris sources. The post launch pad/area configuration shall be documented and photographed.

**Documents:** OMI S0007, OMI S6444

**Report:** Initial report to NTD and verbal

briefing to Level II at L+8 hours;  
generate PR's.

#### 5) Launch Data Review

**Objective:** Detailed review of high speed films video tapes, and photographs from pad cameras, range trackers, aircraft and vehicle onboard cameras to determine possible launch damage to the flight vehicle. Identify debris and debris sources.

**Time:** Launch + 1 day to Launch + 6 days

**Requirements:** OMRSD S00U00.011 - An engineering film review and analysis shall be performed on all engineering launch film as soon as possible to identify any debris damage to the shuttle vehicle. Identify flight vehicle or ground system damage that could affect orbiter flight operations or future SSV launches.

**Documents:** OMI S6444

**Report:** Daily reports to Level II Mission Management Team starting on L+1 day through landing; generate PR's.

#### 6) SRB Post Flight/Retrieval Inspection

**Objective:** Evaluate potential SRB debris sources. Data will be correlated with observed Orbiter post landing TPS damage.

**Areas:** SRB external surfaces (Hangar AF, CCAFS)

**Time:** Launch + 24 hours (after on-dock, before hydrolasing)

**Requirements:** OMRSD S00U00.013 - An engineering debris damage inspection team shall perform a post retrieval inspection of the SRB's to identify any damage caused by launch debris. Any anomalies must be documented/photographed and coordinated with the results of the post launch shuttle/pad area debris inspection.

**Documents:** OMI B8001

**Report:** Daily reports to Level II Mission Management Team. Preliminary report to SRB Disassembly Evaluation Team. Generate PR's.

## 7) Orbiter Post Landing Debris Damage Assessment

**Objective:** Identify and evaluate areas of damage to Orbiter TPS due to debris and correlate, if possible, source and time of occurrence. Additionally, runways are inspected for debris and sources of debris.

**Areas:** Orbiter TPS surfaces, runways

**Time:** After vehicle safing on runway, before towing

**Requirements:** OMRSD S00U00.040 - An engineering debris inspection team shall perform a prelanding runway inspection to identify, document, and collect debris that could result in orbiter damage. Runway debris and any facility anomalies which cannot be removed or corrected by the Team shall be documented and photographed; the proper management shall be notified and corrective actions taken.

**Requirements:** OMRSD S00U00.050 - An engineering debris inspection team shall perform a post landing runway inspection to identify and resolve potential debris sources that may have caused vehicle damage but was not present or was not identified during pre-launch runway inspection. Obtain photographic documentation of any debris, debris sources, or flight hardware that may have been lost on landing.

**Requirements:** OMRSD S00U00.060 - An engineering debris inspection team shall map, document, and photograph debris-related Orbiter TPS damage and debris sources.

**Requirements:** OMRSD S00U00.012 - An engineering debris damage inspection team shall perform a post landing inspection of the orbiter vehicle to identify any damage caused by launch debris. Any anomalies must be documented, photographed and coordinated with the results of the post launch shuttle/pad area debris inspection.

**Requirements:** OMRSD V09AJ0.095 - An engineering debris inspection team shall perform temperature measurements of RCC nose cap and RCC RH wing leading edge panels 9 and 17.

**Documents:** OMI S0026, OMI S0027, OMI S0028

**Report:** Briefing to NASA Convoy Commander

and generate PR's. Preliminary report to Level II on the day of landing followed by a preliminary update the next day.

8) Level II report

Objective:

Compile and correlate data from all inspections and analyses. Results of the debris assessment, along with recommendations for corrective actions which are presented directly to Level II via SIR and PRCB. Paper copy of complete report follows in 3-4 weeks. (Ref NASA Technical Memorandum series)

### 3.0 PRE-TEST BRIEFING

The Ice/Frost/Debris Team briefing for launch activities was conducted on 9 April 1990 at 0800 hours with the following key personnel present:

C. Stevenson	NASA - KSC	Chief, ET Mechanical Systems Lead, Ice/Debris Assess Team
G. Katnik	NASA - KSC	ET Mech/TPS, STI, Ice/Debris Assessment
S. Higginbotham	NASA - KSC	STI, Ice/Debris Assessment
P. Rosado	NASA - KSC	ET Mech/TPS, ET Processing
B. Speece	NASA - KSC	ET Processing, Ice Assess
J. Rivera	NASA - KSC	ET Processing, Debris Assess
B. Davis	NASA - KSC	STI, Debris Assessment
K. Tenbusch	NASA - KSC	"SURFICE", Debris Assess
M. Young	LSOC - SPC	ET Processing, Ice Assess
M. Jaime	LSOC - SPC	ET Processing, Ice Assess
R. Seale	LSOC - SPC	ET Processing, Ice Assess
F. Huneidi	NASA - MSFC	TPS & Ice Assessment
Z. Byrns	NASA - JSC	Level II Integration
C. Gray	MMC - MAF	ET TPS & Materials Design
S. Copsey	MMC - MAF	ET TPS Testing/Certif
K. Ely	MMC - KSC	ET Processing, LSS
J. McClymonds	RI - Downey	Debris Assess, LVL II Integ
T. Thorson	RI - LSS	Vehicle Integration
H. Novak	USBI - PSE	SRB Processing
R. McDonald	USBI - LSS	SRB Processing
K. Parsons	MTI - LSS	SRM Processing
D. Paniale	LSOC - SPC	Safety

These personnel participated in various team activities, assisted in the collection and evaluation of data, and wrote reports contained in this document.

### 3.1 PRE-LAUNCH SSV/PAD DEBRIS INSPECTION

The pre-launch debris inspection of the pad and Shuttle vehicle was conducted on 9 April 1990 from 1000 - 1200 hours. The detailed walkdown of Launch Pad 39B and MLP-2 also included the primary flight elements OV-103 Discovery (10th flight), ET-34 (LWT-27), and BI037. Documentary photographs were taken of facility anomalies, potential sources of vehicle damaging debris, and new vehicle configurations.

There were no major vehicle anomalies. However, instafoam residue/overspray was present on the vehicle side of the hold down posts from the SRB aft skirt instafoam spraying operation. Engineering will modify the spraying procedures to eliminate the overspray problem.

Due to the continued concern over potential hydrogen leakage from the ET/ORB LH2 umbilical interface area during the cryoload/launch of STS-29R, a temporary hydrogen detector was installed at the ET/ORB LH2 umbilical until a permanent sensor can be designed and installed. The temporary system consists of two tygon tubes that run from the LH2 umbilical area through the LH2 TSM to the hazardous gas detection equipment. The tubes were attached to the vehicle by three velcro strap assemblies. A length of parachute cord attached to these assemblies enable the entire apparatus to be quickly removed from the vehicle without causing TPS damage. The hydrogen sensor is intended to remain in place during cryo loading and be removed by the Ice Inspection Team during the T-3 hour hold.

A recurring problem is loose MLP deck bolts. This inspection revealed loose bolts on the raised deck between the SRB's and loose bolts/groundwires at the handrail standoffs.

Other discrepancies included loose electrical pipes/endcaps on the deck access plates and in between the SRB exhaust holes. The electrical conduit cover in the northwest corner of the MLP was loose while the cover for the electrical conduit in the northeast corner of the MLP was missing altogether.

Trash and debris was visible in several areas under the raised decks.

Cleanup of the MLP deck and pad surface was almost complete at the time of the inspection. The facility discrepancies were worked real-time or were entered in S0007 Appendix K as open work prior to vehicle tanking.





Prelaunch overall view of LO2 ET/ORB umbilical



Overall view of LH2 ET/ORB umbilical. Note PDL foam plug in flapper valve actuator torque tool port closeout (arrow)

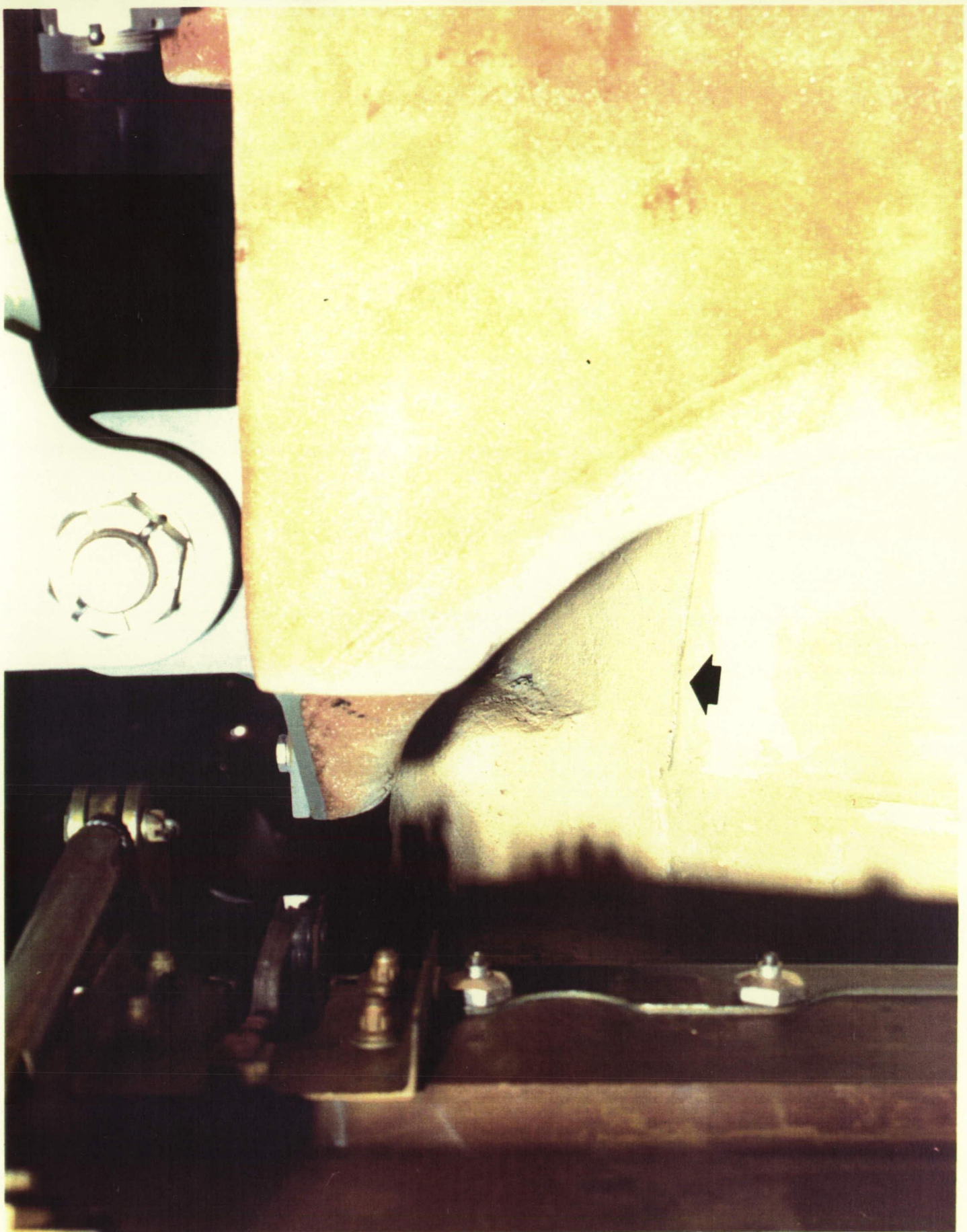

TPS interface at fwd inboard area of LH2 ET/ORB umbilical may result in a thermal short when vehicle is cryo-loaded

#### 4.0 SCRUB

The launch countdown for STS-31R was scrubbed at 0850 EST on 10 April 1990 due to an irregular speed indication on APU #1.

#### 4.1 ICE/FROST INSPECTION

The Ice/Frost Inspection of the cryoloaded vehicle was performed on 10 April 1989 from 0500 to 0631 hours during the two hour built-in-hold at T-3 hours in the countdown. There was one waiver to the Launch Commit Criteria (non-functioning heater), but no violations to NSTS-08303. Ambient weather conditions at the time of the inspection were:

Temperature:	70.5 F
Relative Humidity:	74.6 %
Wind Speed:	14.1 Knots
Wind Direction:	94.3 Degrees

The portable STI infrared scanner was utilized to obtain surface temperature measurements for an overall thermal assessment of the vehicle, as shown in Figure 1 and 2.

#### 4.2 ORBITER OBSERVATIONS

No Orbiter tile anomalies were observed. The average Orbiter surface temperature was recorded as 66 degrees F. The surface temperatures of the SSME engine mounted heat shields were measured at 65 degrees F for SSME #1 (coldest 26 degrees F), 63 degrees F for SSME #2 (coldest 32 degrees F), and 65 degrees F for SSME #3 (coldest 36 degrees F). Less than usual amount of ice/frost was present at the nozzle to heatshield interfaces. Condensate, but no ice or frost, was present on SSME #1 and #2 heatshields; SSME #3 heat shield was dry.

#### 4.3 SRB OBSERVATIONS

No SRB anomalies or loose ablator/cork were observed. The STI portable infrared scanner recorded RH and LH SRB case surface temperatures between 65 to 69 degrees F. In comparison, SRB case temperatures were 67 degrees F as measured by the GEI. Temperatures in the area of the SRB field joint heater closeouts averaged 78 degrees F. The predicted Propellant Mean Bulk Temperature (PMBT) supplied by MTI was 69 degrees F.

# FIGURE 1. SSV INFRARED SCANNER SURFACE TEMPERATURE SUMMARY DATA

TIME: 0500-0631  
 DATE: 4/10/90  
 VEH. STS- 31R

NOTE: ALL MEASUREMENTS  
 IN DEGREES F.

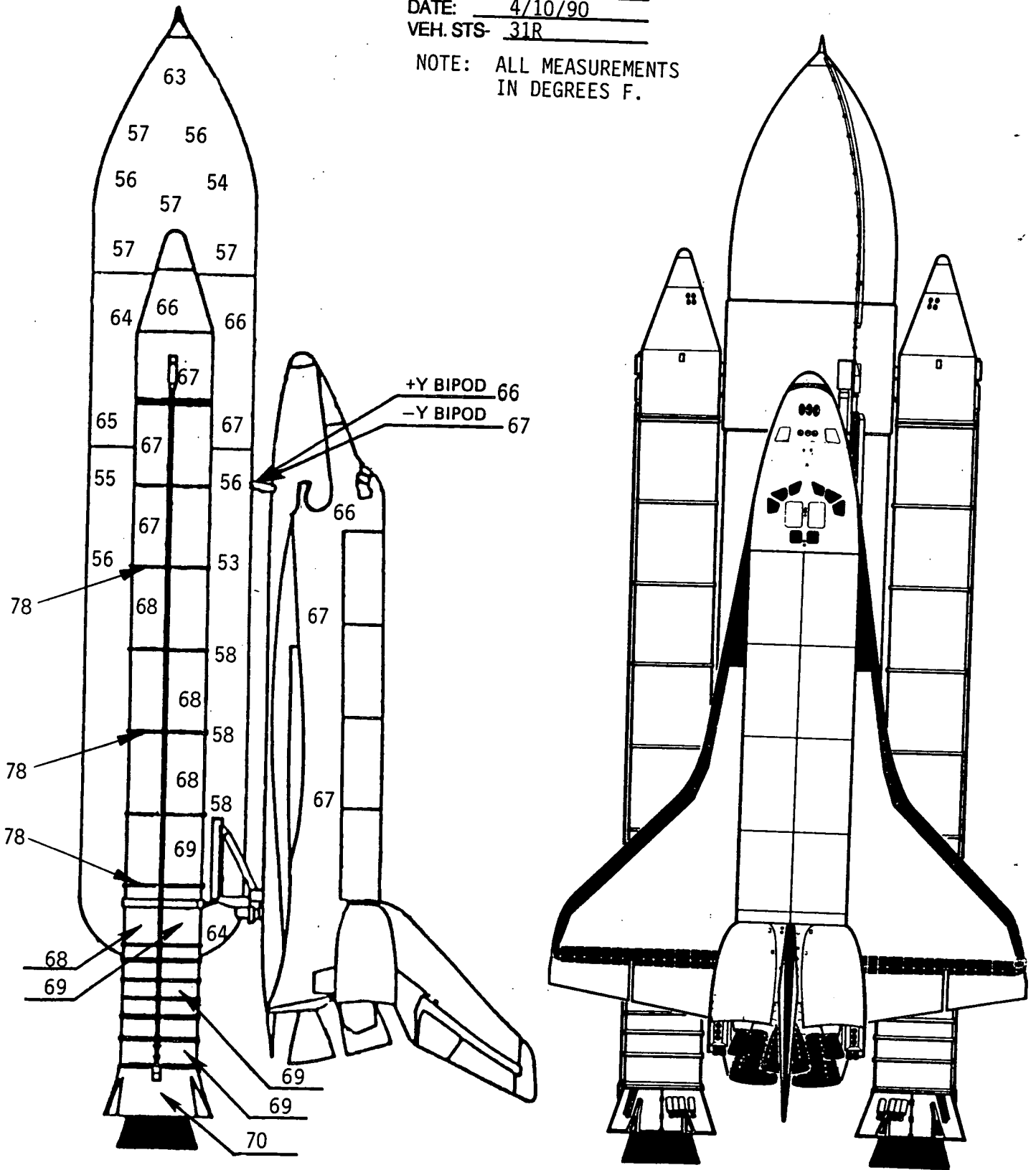



#### 4.4 EXTERNAL TANK OBSERVATIONS

The ice/frost prediction computer program was run from 0030 to 0830 hours and the results tabulated in Figures 3-5. The program predicted condensate with no ice accumulation on all TPS acreage surfaces.

Very light condensate, but no ice or frost, was present on the -Z side of the LO2 tank. There were no TPS anomalies. The tumble valve cover was intact. The STI IR scanner measured an average surface temperature of 63 degrees F on the ogive and 56 degrees F on the barrel section, compared to a SURFICE prediction of 60 degrees and 57 degrees, respectively.

Very light run-on condensate was present on the intertank. There were no TPS anomalies. Small frost spots had accumulated on the first 4 stringers at the LO2 tank-to-intertank flange in the -Y-Z quadrant. The STI IR scanner measured an average surface temperature of 66 degrees. Some frost had formed around the GUCP, but there was no sign of leakage.

A light amount of condensate trickled down the LH2 tank and ran off the aft dome. There was no acreage ice/frost and no TPS anomalies. The average surface temperatures as measured by the STI IR scanner were 56 degrees F, compared to 58 degrees F predicted by SURFICE.

Small frost spots 3/4-inch in diameter had formed around both bipod DFI box drain holes. There was very minor outgassing from the holes, which was not an IPR condition.

Ice/Frost covered the lower EB fittings outboard to the strut pin hole with condensate on the rest of the fitting. The struts were dry and were not covered by ice.

Normal amounts of ice were present in all LO2 feedline bellows. Less than usual amounts of ice/frost were present in the LO2 feedline support brackets. There was no ice/frost at the LO2 feedline attach bracket to the crossbeam due to a non-functioning heater. Appendix F of the LCC had been modified to accept 22 square inches of ice in this area per a Level II Change Request.

There was the usual amount of ice in the LH2 feedline bellows. A normal amount of ice had formed in the LH2 recirculation line bellows and burst disks.

The LH2 ET/ORB umbilical exhibited the usual accumulation of ice. The LO2 ET/ORB umbilical exhibited typical (light) ice/frost accumulations. Frost fingers had formed on the purge vents and normal venting was occurring. There was no evidence of cold gas venting or frost around the umbilical aft vent holes. There were no unusual vapors emanating from the umbilicals nor any evidence of leakage.

STS- 31R		TEST S0007 SCRUB, ERATIC APU TURBINE SPEED										DATE: 10 April 1990		T-0 TIME DATE															
ORBITER 103	ET 34	SRB BI-037	MLP 2	PAD B	LO2		LH2		LH2		LH2		LH2		LH2														
					CHILLDOWN TIME: SLOW FILL TIME:	FAST FILL TIME: REPLENISH TIME:	CHILLDOWN TIME: SLOW FILL TIME:	FAST FILL TIME: REPLENISH TIME:	CHILLDOWN TIME: SLOW FILL TIME:	FAST FILL TIME: REPLENISH TIME:	CHILLDOWN TIME: SLOW FILL TIME:	FAST FILL TIME: REPLENISH TIME:																	
					LO2 TANK STA 370 TO 540					LO2 TANK STA 550 TO 852					LO2 TANK STA 1130 TO 1380														
CONDITIONS					LO2 TANK STA 370 TO 540					LO2 TANK STA 550 TO 852					LO2 TANK STA 1130 TO 1380														
TIME (EDT)	TEMP F	REL. HUM. %	DEW PT F	WIND VEL KNTS	WIND DIR DEG	LOCAL VEL KNTS	SOFI TEMP	COND RATE IN/HR	ICE RATE IN/HR	REG	LOCAL VEL KNTS	SOFI TEMP	COND RATE IN/HR	ICE RATE IN/HR	REG	LOCAL VEL KNTS	SOFI TEMP	COND RATE IN/HR	ICE RATE IN/HR	REG	LOCAL VEL KNTS	SOFI TEMP	COND RATE IN/HR	ICE RATE IN/HR	REG	LOCAL VEL KNTS	SOFI TEMP	COND RATE IN/HR	ICE RATE IN/HR
0030	69.80	70.80	60.13	18	98	10.62	59.88	0.0002	-0.2795	II	10.62	57.49	0.0022	-0.2482	II	9.90	56.65	0.0027	-0.2257	II	21.96	59.99	0.0002	-0.5079	II	17.08	58.96	0.0011	-0.3911
0045	69.80	70.00	59.82	14	99	8.26	58.91	0.0006	-0.2203	II	8.26	55.94	0.0025	-0.1899	II	7.70	54.91	0.0029	-0.1712	II	17.08	58.96	0.0011	-0.3911	II	17.08	58.96	0.0011	-0.3911
0100	69.80	70.80	60.13	15	99	8.85	59.33	0.0006	-0.2369	II	8.85	56.53	0.0025	-0.2060	II	8.25	55.56	0.0030	-0.1862	II	18.30	59.40	0.0010	-0.4231	II	18.30	59.40	0.0010	-0.4231
0015	69.80	71.20	60.29	16	97	9.44	59.63	0.0005	-0.2521	II	9.44	56.98	0.0025	-0.2212	II	8.80	56.06	0.0029	-0.2004	II	19.52	59.72	0.0009	-0.4535	II	19.52	59.72	0.0009	-0.4535
0130	70.00	70.40	60.00	15	95	8.85	59.43	0.0006	-0.2378	II	8.85	56.64	0.0025	-0.2071	II	8.25	55.67	0.0029	-0.1873	II	18.30	59.50	0.0010	-0.4250	II	18.30	59.50	0.0010	-0.4250
0145	70.00	70.80	60.33	14	91	8.26	59.30	0.0007	-0.2244	II	8.26	56.35	0.0026	-0.1938	II	7.70	55.32	0.0030	-0.1749	II	17.08	59.35	0.0013	-0.3983	II	17.08	59.35	0.0013	-0.3983
0200	70.00	71.00	60.41	16	88	9.44	59.78	0.0005	-0.2539	II	9.44	57.14	0.0025	-0.2228	II	8.80	56.22	0.0029	-0.2020	II	19.52	59.87	0.0008	-0.4565	II	19.52	59.87	0.0008	-0.4565
0215	70.00	72.00	60.80	15	90	8.85	59.81	0.0008	-0.2420	II	8.85	57.03	0.0027	-0.2111	II	8.25	56.06	0.0031	-0.1911	II	18.30	59.89	0.0013	-0.4328	II	18.30	59.89	0.0013	-0.4328
0230	70.00	71.80	60.72	15	93	8.85	59.77	0.0007	-0.2415	II	8.85	56.98	0.0027	-0.2106	II	8.25	56.02	0.0031	-0.1906	II	18.30	59.84	0.0013	-0.4318	II	18.30	59.84	0.0013	-0.4318
0245	70.00	71.80	60.72	14	98	8.26	59.54	0.0008	-0.2268	II	8.26	56.59	0.0027	-0.1962	II	7.70	55.57	0.0032	-0.1771	II	17.08	59.60	0.0015	-0.4029	II	17.08	59.60	0.0015	-0.4029
0300	70.20	72.60	61.22	13	95	7.67	59.68	0.0011	-0.2160	II	7.67	56.55	0.0029	-0.1854	II	7.15	55.47	0.0033	-0.1670	II	15.68	59.71	0.0019	-0.3908	II	15.68	59.71	0.0019	-0.3908
0315	70.60	72.60	61.62	15	91	8.85	60.56	0.0009	-0.2502	II	8.85	57.81	0.0028	-0.2191	II	8.25	56.85	0.0032	-0.1986	II	18.30	60.64	0.0015	-0.4475	II	18.30	60.64	0.0015	-0.4475
0330	70.60	72.40	61.54	12	96	7.08	59.75	0.0011	-0.2043	II	7.08	56.43	0.0030	-0.1739	II	6.60	55.29	0.0034	-0.1563	II	14.84	59.75	0.0021	-0.3570	II	14.84	59.75	0.0021	-0.3570
0345	78.20	73.00	61.38	13	97	7.67	59.77	0.0011	-0.2169	II	7.67	56.65	0.0030	-0.1863	II	7.15	55.57	0.0034	-0.1679	II	15.86	59.81	0.0020	-0.3825	II	15.86	59.81	0.0020	-0.3825
0400	70.20	72.60	61.22	14	99	8.26	59.93	0.0009	-0.2309	II	8.26	57.00	0.0029	-0.2002	II	7.70	55.98	0.0033	-0.1808	II	17.08	59.99	0.0017	-0.4103	II	17.08	59.99	0.0017	-0.4103
0415	70.40	72.60	61.42	16	98	9.44	60.56	0.0007	-0.2630	II	9.44	57.95	0.0027	-0.2317	II	8.80	57.03	0.0031	-0.2103	II	19.52	60.65	0.0012	-0.4731	II	19.52	60.65	0.0012	-0.4731
0430	70.20	72.60	61.22	12	95	7.08	59.39	0.0012	-0.2010	II	7.08	56.05	0.0030	-0.1707	II	6.60	54.90	0.0034	-0.1532	II	14.64	59.39	0.0022	-0.3513	II	14.64	59.39	0.0022	-0.3513
0445	70.40	73.00	61.57	16	91	9.44	60.67	0.0008	-0.2641	II	9.44	58.05	0.0028	-0.2328	II	8.80	57.13	0.0032	-0.2113	II	19.52	60.75	0.0013	-0.4752	II	19.52	60.75	0.0013	-0.4752
0500	70.60	73.80	62.07	12	95	7.08	60.08	0.0013	-0.2074	II	7.08	56.77	0.0032	-0.1769	II	6.60	55.63	0.0035	-0.1590	II	14.64	60.09	0.0024	-0.3626	II	14.64	60.09	0.0024	-0.3626
0515	70.80	74.40	62.50	12	91	7.08	60.43	0.0014	-0.2106	II	7.08	57.13	0.0032	-0.1800	II	6.60	55.99	0.0036	-0.1620	II	14.64	60.44	0.0025	-0.3684	II	14.64	60.44	0.0025	-0.3684
0530	70.40	74.60	62.18	15	97	8.85	60.84	0.0011	-0.2533	II	8.85	58.08	0.0030	-0.2221	II	8.25	57.12	0.0035	-0.2014	II	18.30	60.92	0.0019	-0.4535	II	18.30	60.92	0.0019	-0.4535
0545	70.80	74.40	62.50	15	94	8.85	61.20	0.0010	0.2573	II	8.85	58.46	0.0030	-0.2260	II	8.25	57.50	0.0035	-0.2050	II	18.30	61.28	0.0019	-0.4605	II	18.30	61.28	0.0019	-0.4605
0600	70.80	75.20	62.79	15	87	8.85	61.39	0.0011	-0.2595	II	8.85	58.65	0.0031	-0.2281	II	8.25	57.70	0.0036	-0.2070	II	18.30	61.47	0.0021	-0.4645	II	18.30	61.47	0.0021	-0.4645
0615	70.60	75.20	62.60	14	99	8.26	60.96	0.0012	-0.2417	II	8.26	58.05	0.0032	-0.2106	II	7.70	57.04	0.0036	-0.1906	II	17.08	61.03	0.0023	-0.4298	II	17.08	61.03	0.0023	-0.4298
0630	69.20	74.80	61.07	16	97	9.44	59.87	0.0010	-0.2550	II	9.44	57.22	0.0029	-0.2239	II	8.80	56.29	0.0034	-0.2029	II	19.52	59.98	0.0017	-0.4594	II	19.52	59.98	0.0017	-0.4594
0645	68.80	75.80	61.04	15	94	8.85	59.49	0.0012	-0.2386	II	8.85	56.68	0.0031	-0.2077	II	8.25	55.69	0.0035	-0.1877	II	18.30	59.60	0.0021	-0.4274	II	18.30	59.60	0.0021	-0.4274
0700	69.00	76.20	61.39	11	101	6.49	58.65	0.0016	-0.1825	II	6.49	55.03	0.0034	-0.1525	II	6.05	53.78	0.0037	-0.1360	II	13.42	58.65	0.0030	-0.3164	II	13.42	58.65	0.0030	-0.3164
0715	69.60	75.00	61.54	13	98	7.67	59.63	0.0013	-0.2156	II	7.67	56.49	0.0032	-0.1850	II	7.15	55.40	0.0036	-0.1665	II	15.86	59.68	0.0024	-0.3805	II	15.86	59.68	0.0024	-0.3805

FIGURE 3. Ice/Frost Computer Predictions



STS- 31R		TEST S0007 SCRUB, ERATIC APU TURBINE SPEED										DATE: 10 April 1990		T-0 TIME DATE											
ORBITER 103	ET	SRB	MLP	PAD	LO2		LO2		LO2		LO2		LO2		LO2										
	34	BI-037	2	B	CHILLDOWN TIME: 01:56	FAST FILL TIME: 02:45	CHILLDOWN TIME: 02:31	FAST FILL TIME: 04:47	CHILLDOWN TIME: 01:56	FAST FILL TIME: 02:45	CHILLDOWN TIME: 02:31	FAST FILL TIME: 04:47	CHILLDOWN TIME: 01:56	FAST FILL TIME: 02:45	CHILLDOWN TIME: 02:31	FAST FILL TIME: 04:47									
CONDITIONS		LO2 TANK STA 370 TO 540		LO2 TANK STA 550 TO 852		LO2 TANK STA 1130 TO 1380		LO2 TANK STA 1380 TO 2058		LO2 TANK STA 1130 TO 1380		LO2 TANK STA 1380 TO 2058		LO2 TANK STA 1130 TO 1380		LO2 TANK STA 1380 TO 2058									
TIME (EDT)	TEMP F	REL HUM. %	DEW PT F	WIND VEL KNTS	WIND DIR DEG	REG	LOCAL VEL KNTS	SOFI TEMP	COND RATE IN/HR	ICE RATE IN/HR	REG	LOCAL VEL KNTS	SOFI TEMP	COND RATE IN/HR	ICE RATE IN/HR	REG	LOCAL VEL KNTS	SOFI TEMP	COND RATE IN/HR	ICE RATE IN/HR					
0730	69.40	75.00	61.34	13	97	II	7.67	59.43	0.0013	-0.2136	II	7.67	56.28	0.0032	-0.1830	II	7.15	55.19	0.0036	-0.1647	II	15.86	59.48	0.0024	-0.3770
0745	69.80	74.80	61.66	13	98	II	7.67	59.79	0.0013	-0.2171	II	7.67	56.66	0.0032	-0.1865	II	7.15	55.57	0.0036	-0.1680	II	15.86	59.84	0.0024	-0.3832
0800	70.40	74.40	62.10	14	96	II	8.26	60.57	0.0011	-0.2375	II	8.26	57.64	0.0031	-0.2066	II	7.70	56.63	0.0035	-0.1868	II	17.08	60.63	0.0021	-0.4223
0815	71.20	74.60	62.96	14	90	II	8.26	61.42	0.0012	-0.2467	II	8.26	58.54	0.0032	-0.2155	II	7.70	57.54	0.0036	-0.1952	II	17.08	61.49	0.0022	-0.4385
0830	70.80	74.40	62.50	12	94	II	7.08	60.43	0.0014	-0.2106	II	7.08	57.13	0.0032	-0.1800	II	6.60	55.99	0.0036	-0.1620	II	14.64	60.44	0.0025	-0.3684
AVG	70.36	73.16	61.35	14.1	E		8.35	59.99				8.35	57.05				7.78	56.04				17.26	60.05		

FIGURE 4. Ice/Frost Computer Predictions

FIGURE 5. Surface Temperature From SurfaceC

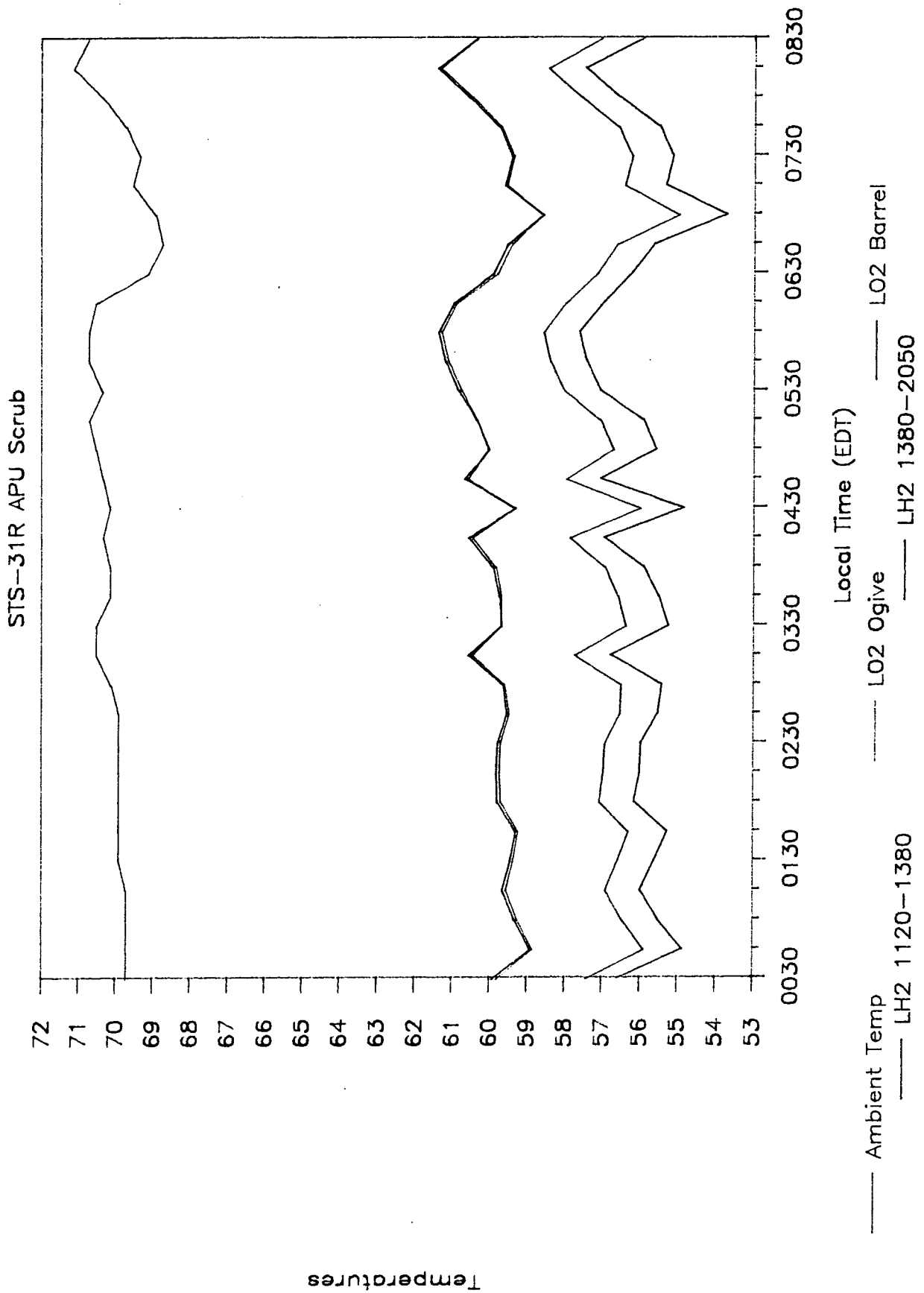

The ET/ORB hydrogen detection sensor tygon tubing was removed with no damage to the vehicle.

The summary of ice/frost team observation anomalies consists of 8 OTV recorded items:

Anomaly 001 and 002 documented the appearance of frost and vapors from the -Y and +Y bipod DFI box drain holes. Frost formation is caused by the movement of cold gas from the DFI box through the vent hole. The frost formations did not violate the LCC.

Anomaly 003 recorded two frost spots inside the north GOX vent duct and minor frost accumulation around the duct perimeter. The frost was examined by the Ice Inspection Team on the pad and did not violate the Launch Commit Criteria.

Ice/frost formed in the LO2 feedline bellows and support brackets (Anomaly 004). The ice/frost was acceptable per NSTS-08303.

The development of ice/frost areas on the LH2 ET/ORB umbilical, cable tray/umbilical interface, and in the recirculation line bellows was listed on Anomaly 005. The areas were acceptable per NSTS-08303.

Anomaly 006 documented ice/frost formation on the LH2 ET/ORB umbilical, which was acceptable per NSTS-08303.

Anomaly 007 recorded the formation of frost fingers on the LO2 ET/ORB umbilical purge vents. These were acceptable per NSTS-08303.

Frost formed on the +Y ET/SRB cable tray DFI microphone island and in the vertical strut cable tray interface (Anomaly 008). These conditions were acceptable per NSTS-08303.

#### **4.5 FACILITY OBSERVATIONS**

All debris concerns previously identified had been resolved prior to cryoloading and no new items were noted during the walkdown. No leaks were observed on either the LO2 or LH2 ORB T-0 umbilicals, though small amounts of ice had formed. Some condensate dripped from the LO2 TSM umbilical. There was no apparent leakage anywhere on the GH2 vent line or GUCP. Some ice/frost, which was expected, had accumulated on the GUCP legs. Visual and infrared observations of the GOX seals confirmed no leakage. The ends of the GOX vent ducts exhibited no icicles. The SRB sound suppression water troughs were full.

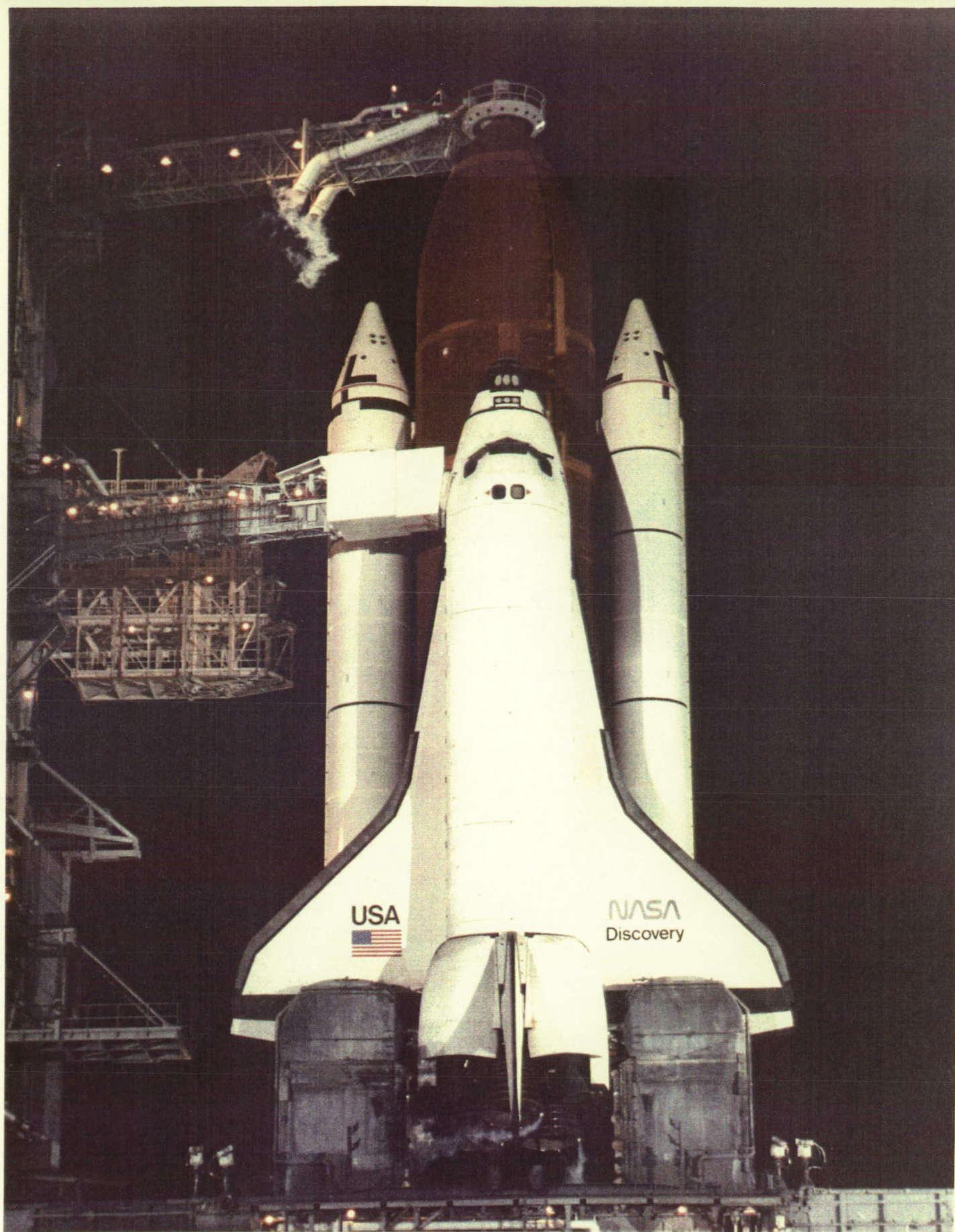

OV-103 Discovery, ET-34 (LWT 27), BIO37, MLP-2, Pad 39B

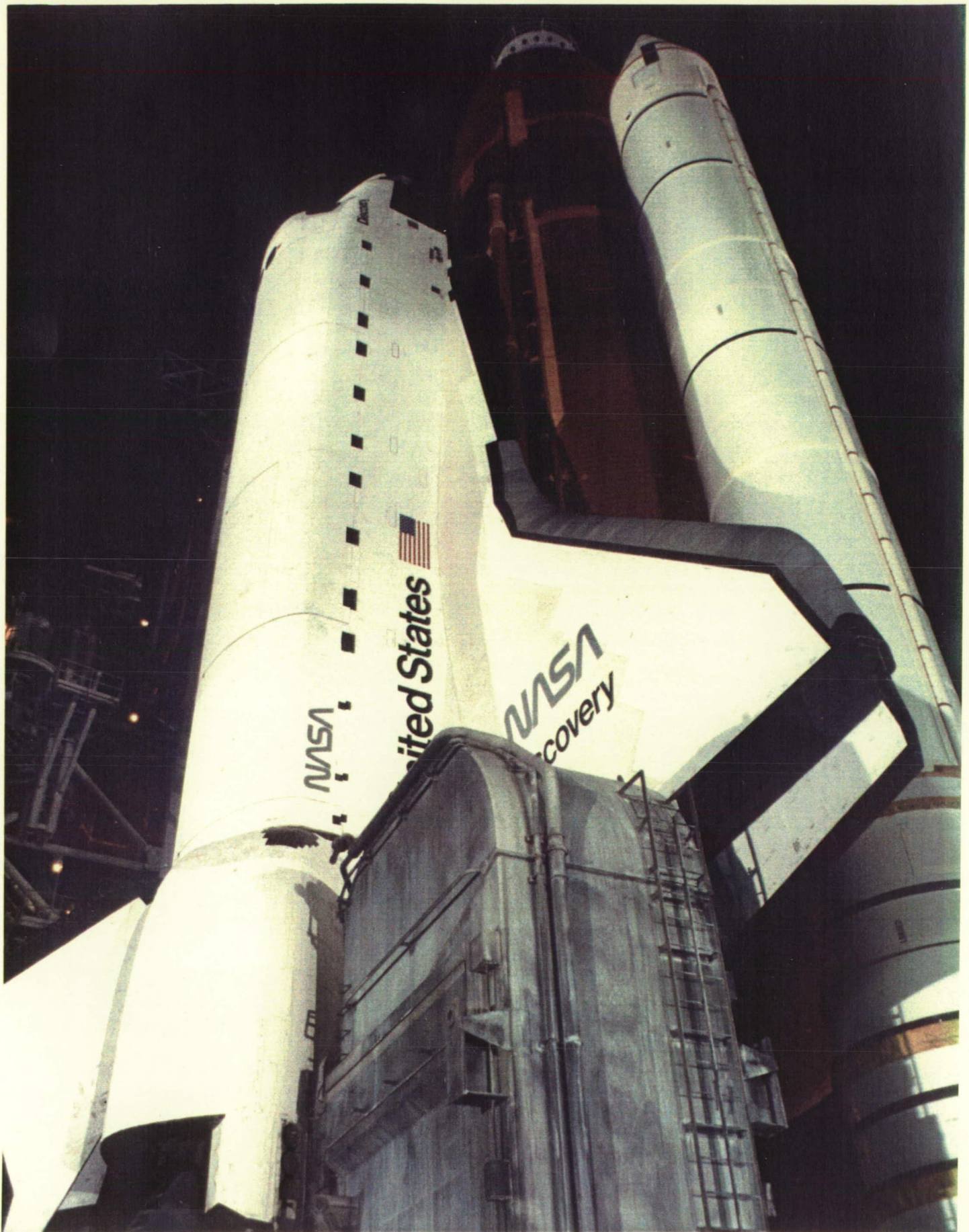

No ice/frost formed on the ET acreage +Y+Z side

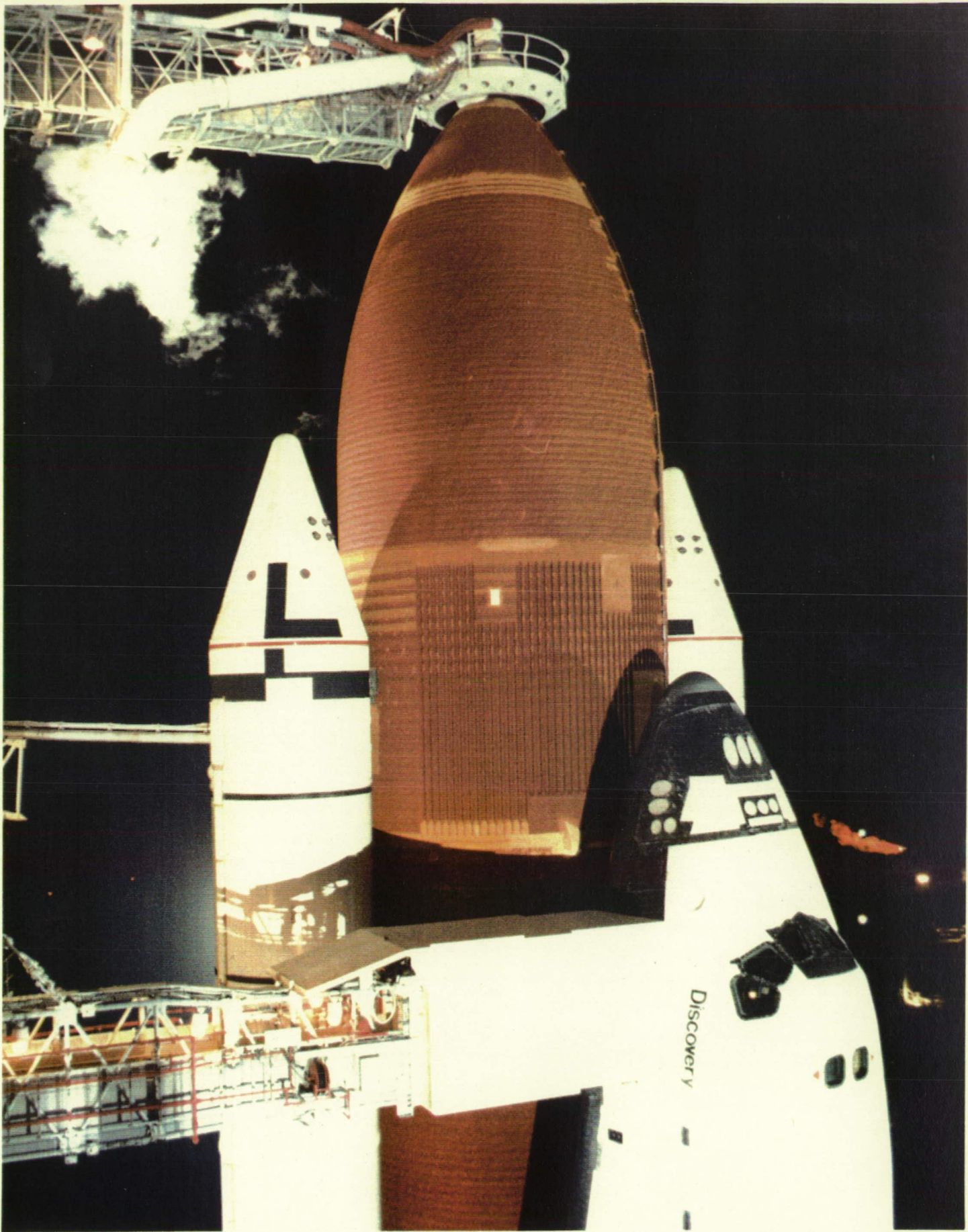

No acreage ice/frost was present on the L02 tank acreage  
ogive and barrel section

25

ORIGINAL PAGE IS  
OF POOR QUALITY

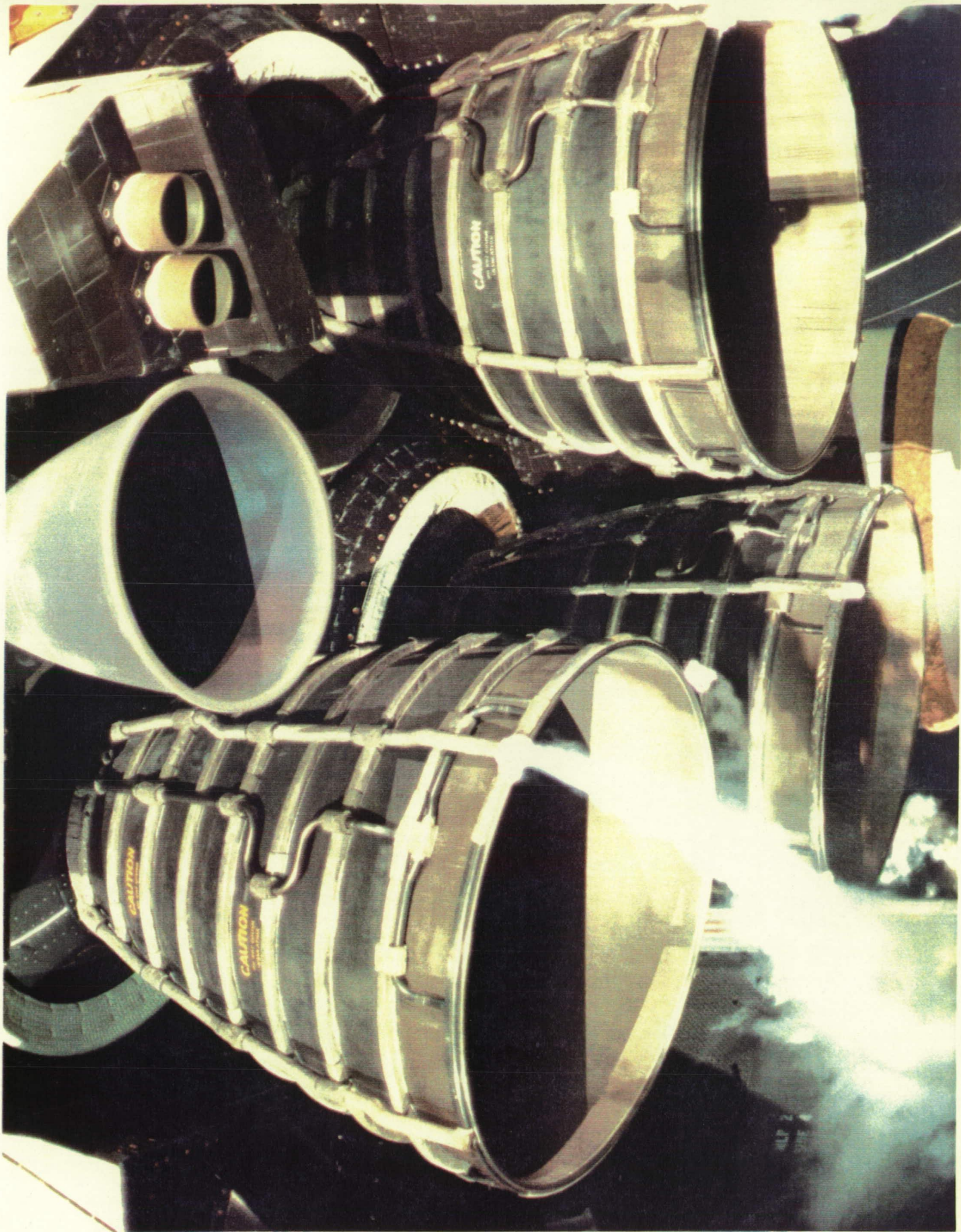

Less than usual amount of ice/frost formed at the main engine  
to heat shield interfaces

26

ORIGINAL PAGE  
COLOR PHOTOGRAPH

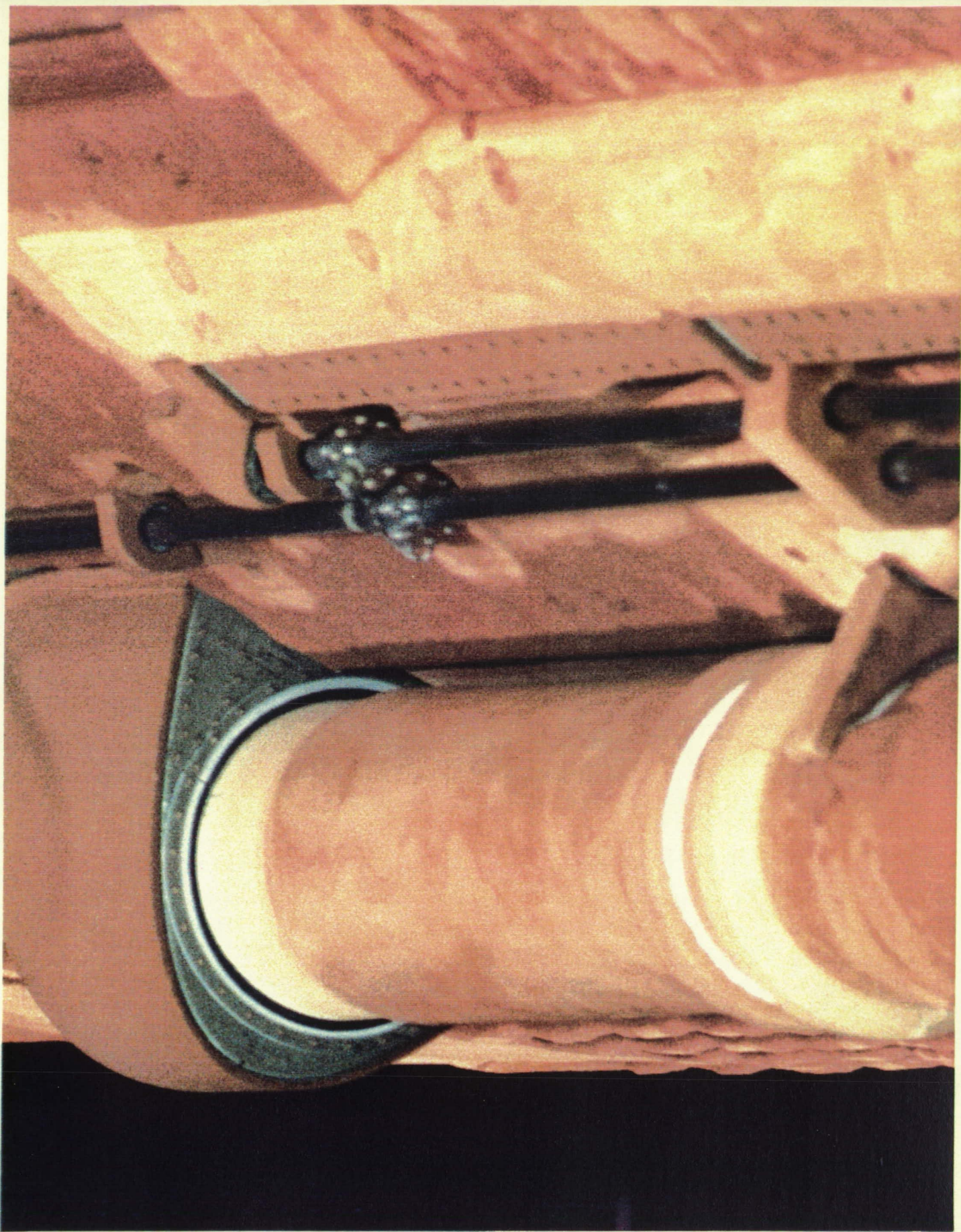

Typical amounts of ice/frost accumulated in the L02 feedline  
support bracket and upper bellows



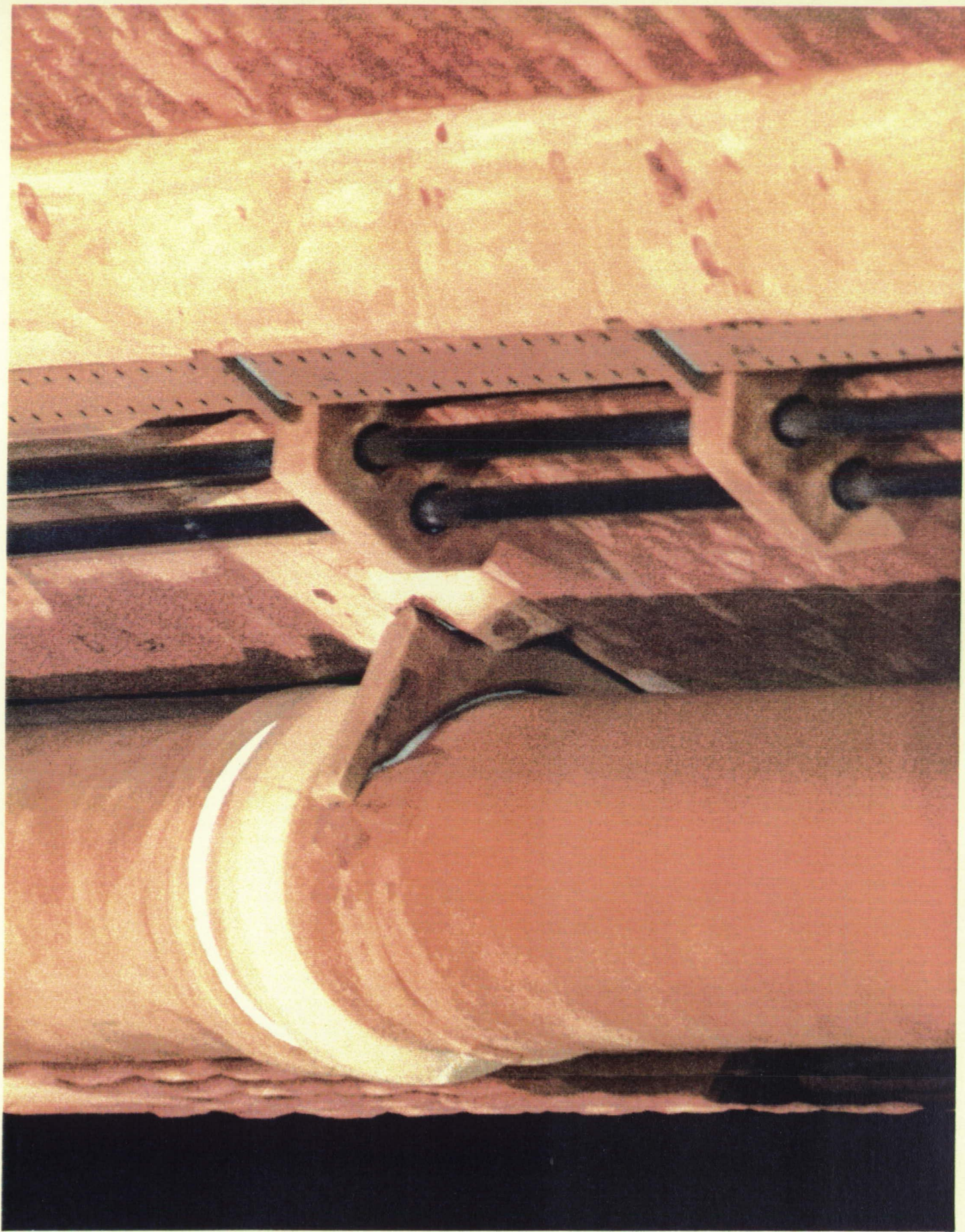

Typical amounts of ice/frost had formed in the L02 feedline support brackets and bellows



Ice/frost accumulation on the LO2 ET/ORB umbilical occurred on the aft and inboard sides, and on the purge vents

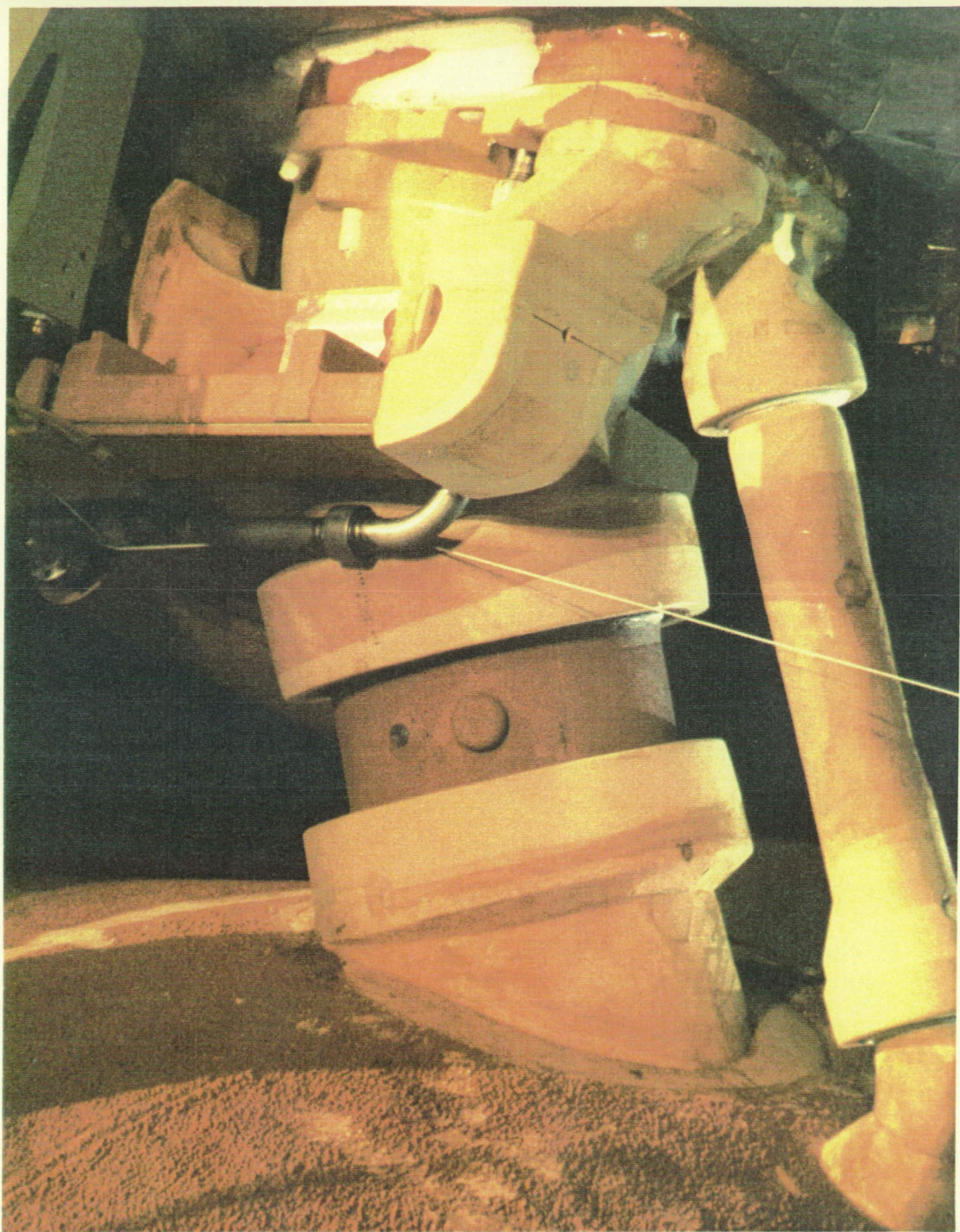

Ice/frost accumulation on the top and outboard sides of the LH2 umbilical was typical. Note frost fingers on purge vents.

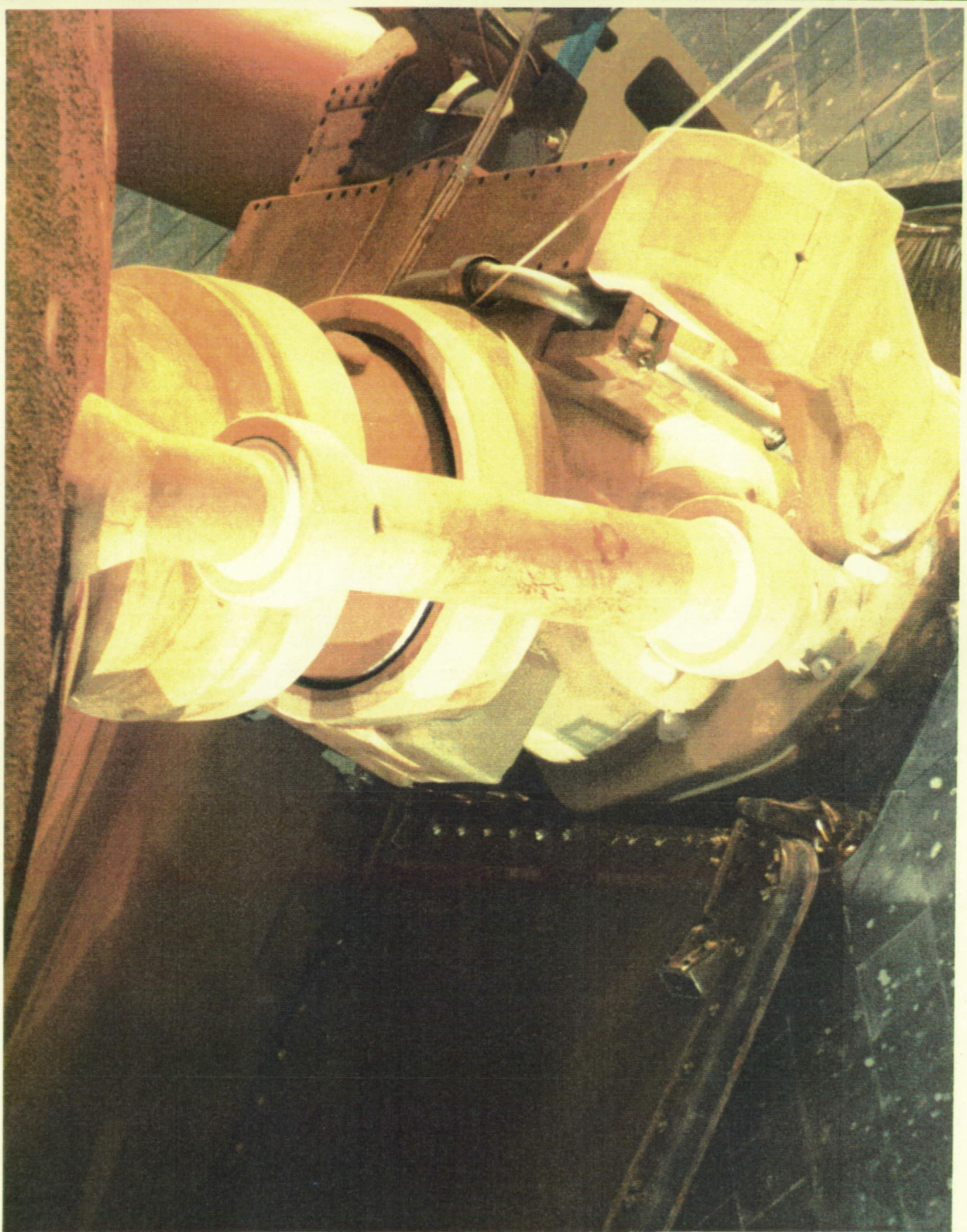

Normal amounts of ice/frost had formed in the LH2 recirculation line bellows. No ice was present in the LH2 feedline bellows.



Ice/frost typically covers the 1-1/2 inch high point bleed QD  
purge shroud

#### 4.6 POST DRAIN INSPECTION

The STS-31R launch was scrubbed at T-4 minutes due to an irregular speed indication on APU #1. Both the LH2 and L02 tanks had been filled to 100 percent. A post-drain inspection of both the vehicle and the MLP deck was performed at Pad 39B from 1340 to 1500 hours on 10 April 1990.

The tumble valve cover exhibited no anomalies. The -Y nosecone footprint area showed no damage. However, the upper half of the grid markings appeared to be slightly faded. The +Y nosecone footprint area was not accessible for inspection.

No TPS damage, such as divots or cracks on the tank acreage, were visible.

Ice had accumulated in both LH and RH SRB cable tray-to-upper strut fairing interfaces. Ice/frost was also present on the +Y and -Y aft fairing flow restrictors. Ice remained on the +Y ET/SRB cable tray instrumentation island. Heavy ice had not melted from the EB-7 and EB-8 fittings.

A crack, 10 inches in length, was visible in the +Y LH2 longeron-to-thrust strut TPS. This has typically occurred after detanking other vehicles and was acceptable per NSTS-08303.

Ice/frost in the L02 feedline bellows had melted. All feedline support brackets had considerably less ice than normal and appeared to have no TPS damage. There was no ice/frost on the L02 ET/ORB umbilical.

A small amount of solid ice still remained in the LH2 feedline bellows and LH2 recirculation line bellows. Solid ice (6 inches long) was attached to five of the LH2 umbilical purge vents. Ice/frost 1 inch in diameter was present on the aft side of the LH2 umbilical cable tray outboard of the vent hole.

All of this ice/frost has occurred previously on other vehicles and is acceptable per NSTS-08303.

There were no Orbiter or SRB TPS anomalies.

The SRB sound suppression water troughs were full.

Cryo boil-off in the ET was complete at 0600 on 11 April 1990.

The summary of ice/frost team observation anomalies consists of 3 OTV recorded items:

Anomaly 009 documented vapors emanating from the cable tray/pressurization line supports at stations 1334, 1399, 1464, 1528, and 1593 during LH2 detank. Vapors were caused by SLA outgassing. Post drain inspection revealed no TPS damage.

Anomaly 010 recorded a crack in the +Y longeron-to-thrust strut interface. This condition is acceptable per NSTS-08303.

An ice/frost ball was present on the LH2 ET/ORB umbilical cable tray. The ice/frost was probably associated with a bondline or local thin TPS area. This was acceptable per NSTS-08303.



Hard ice is still present on the LH2 umbilical outboard side, purge vents, feedline and recirc line bellows after ET drain



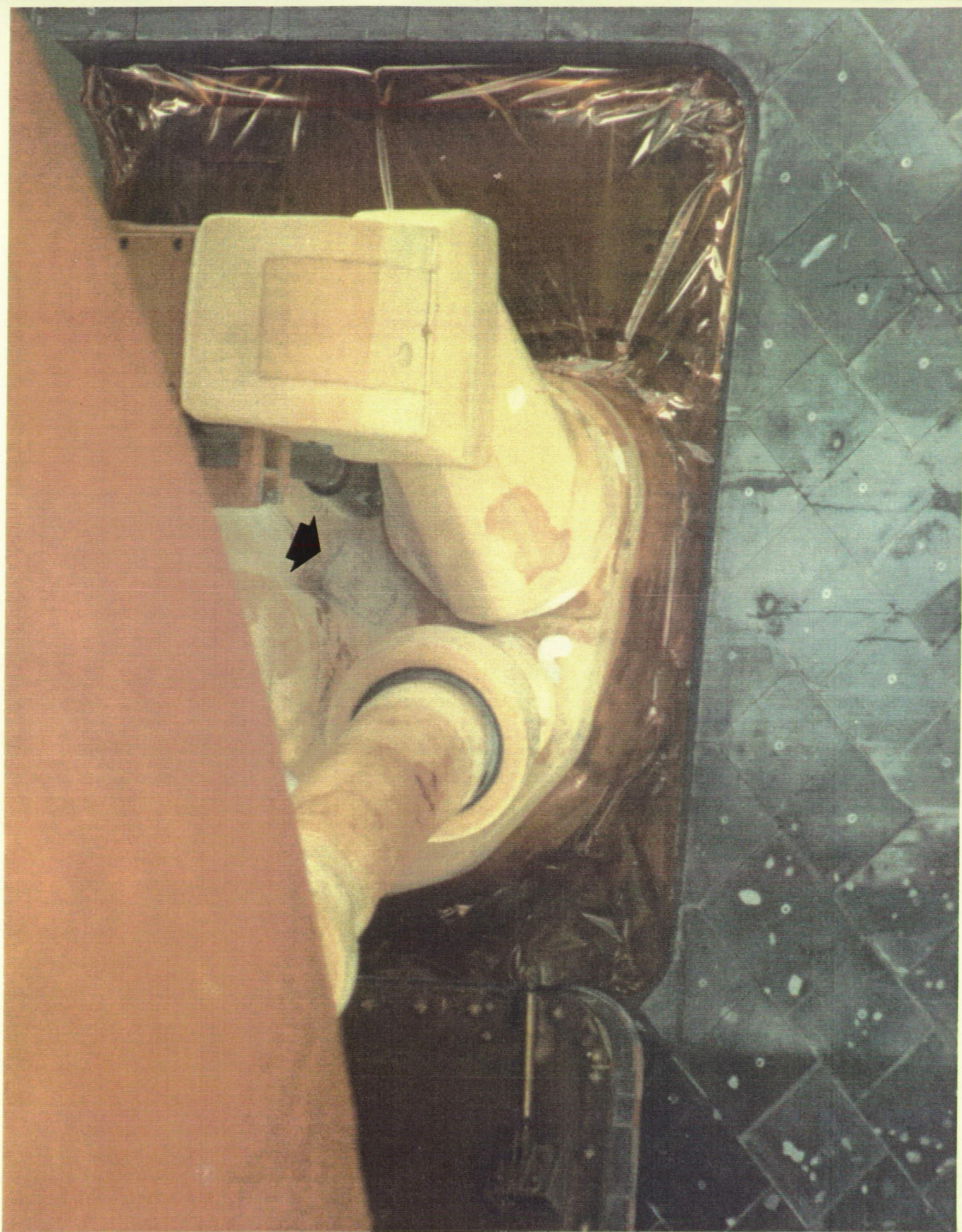

The PDL foam plug in the flapper valve actuator torque tool port closeout shows no anomalies after the first cryo-load

## 5.0 LAUNCH

Due to the 14 day delay until the next launch attempt, another pre-test briefing was conducted with members of the Ice and Debris Team. A pre-launch debris inspection of the SSV and pad was performed on 23 April 1990. The only significant items found were grease/foam residue on the top side of a sound suppression water pipe, a tie-wrap under the raised deck around the SSME exhaust hole, and a piece of cloth hanging on the west wall of the SSME exhaust hole. These items were dispositioned prior to cryo-loading.

A missing 3-inch diameter foam repair in the LH2 tank aft dome apex was observed during installation of the hydrogen detection system tygon tubing. This condition was repaired per PR ET-34-TS-0044 prior to launch.

### 5.1 ICE/FROST INSPECTION

STS-31R was launched at 24:12:33:51 GMT on 24 April 1990.

The Ice/Frost Inspection of the cryoloaded vehicle was performed on 10 April 1989 from 0330 to 0525 hours during the two hour built-in-hold at T-3 hours in the countdown. There was one waiver to NSTS-08303 (LH2 umbilical) and one waiver to the Launch Commit Criteria (non-functioning heater). Ambient weather conditions at the time of the inspection were:

Temperature:	70.4 F
Relative Humidity:	67.0 %
Wind Speed:	11.1 Knots
Wind Direction:	72.1 Degrees

The portable STI infrared scanner was utilized to obtain surface temperature measurements for an overall thermal assessment of the vehicle, as shown in Figure 6 and 7.

### 5.2 ORBITER OBSERVATIONS

No Orbiter tile anomalies were observed. The Orbiter surface temperatures ranged from 64 to 67 degrees F. The average surface temperatures of the SSME engine mounted heat shields were measured at 67 degrees F (coldest area 49 degrees F) on SSME #1, 64 degrees F (coldest area 33 degrees F) on SSME #2, and 67 degrees F (coldest area 52 degrees F) on SSME #3. Ice/frost was present at the nozzle to heatshield interfaces: 5-7 and 9-12 o'clock on SSME #1, 12-2 and 3-10 o'clock on SSME #2. Condensate, but no ice or frost, was present on SSME #1 and #2 heatshields; SSME #3 heat shield was dry. There were no GOX vapors originating from the interior of the SSME nozzles.

**FIGURE 6. SSV INFRARED SCANNER  
SURFACE TEMPERATURE  
SUMMARY DATA**

TIME: 0330-0523  
 DATE: 4/24/90  
 VEH. STS- 31R

NOTE: ALL MEASUREMENTS  
 IN DEGREES F.

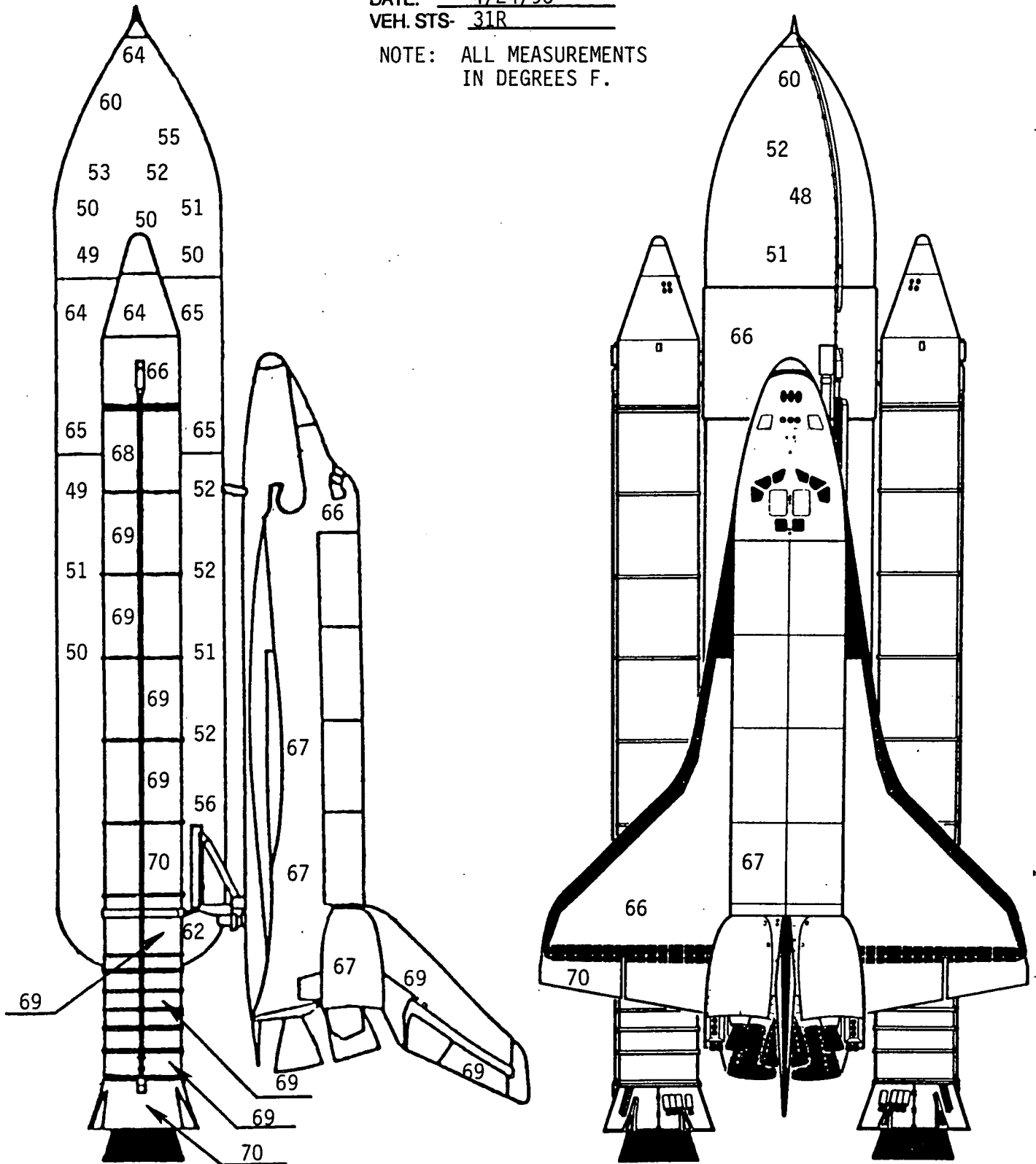

**FIGURE 7. SSV INFRARED SCANNER  
SURFACE TEMPERATURE  
SUMMARY DATA**

TIME: 0330-0523  
 DATE: 4/24/90  
 VEH. STS- 31R

NOTE: ALL MEASUREMENTS  
 IN DEGREES F.

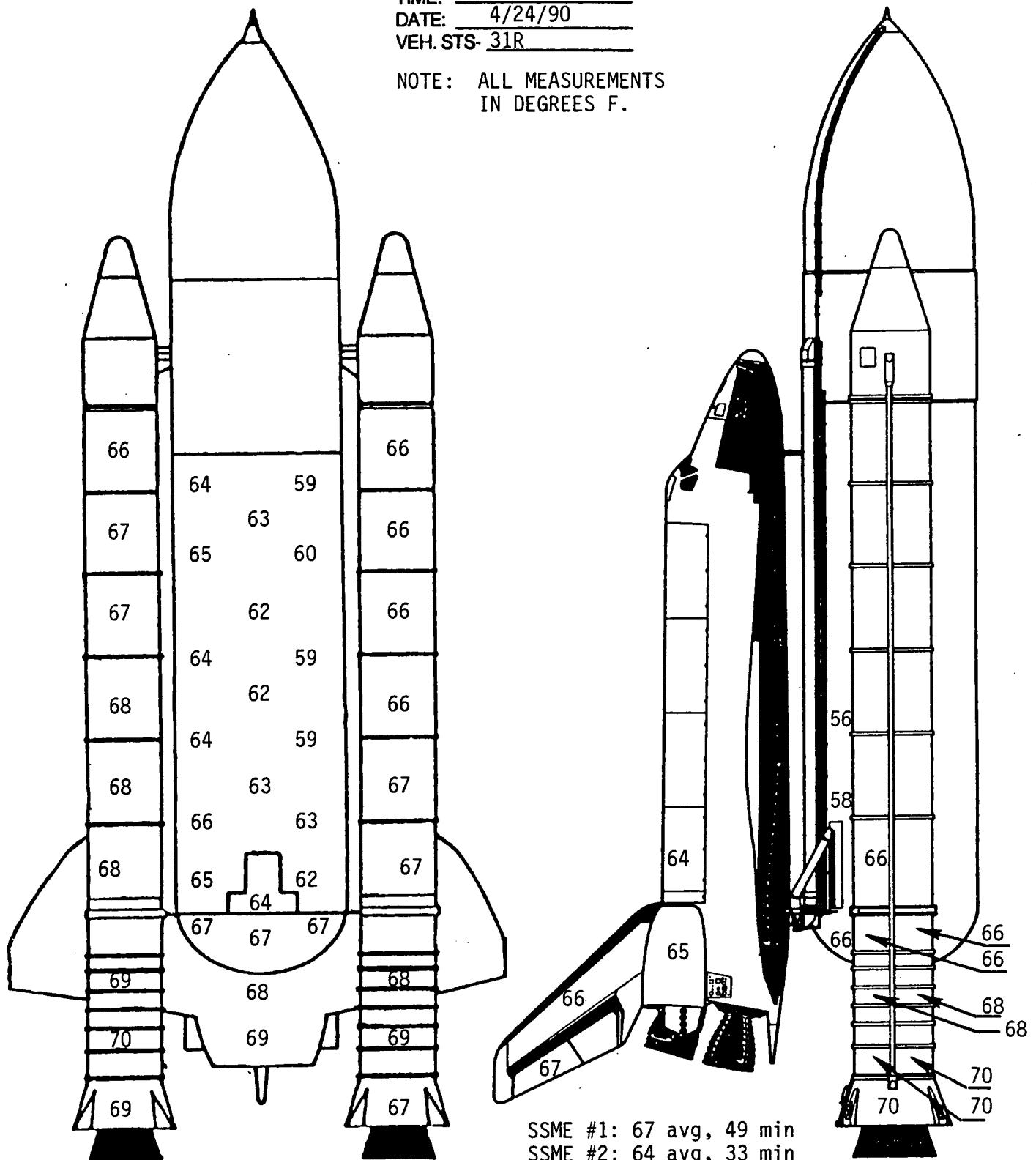

SSME #1: 67 avg, 49 min  
 SSME #2: 64 avg, 33 min  
 SSME #3: 67 avg, 52 min

### 5.3 SRB OBSERVATIONS

No SRB anomalies or loose ablator/cork were observed. The STI portable infrared scanner recorded RH and LH SRB case surface temperatures between 66-69 degrees F. In comparison, SRB case temperatures were 66-70 degrees F as measured by the Mikron IR gun. The predicted Propellant Mean Bulk Temperature (PMBT) supplied by MTI was 69 degrees F.

### 5.4 EXTERNAL TANK OBSERVATIONS

The ice/frost prediction computer program was run from 0030 to 0830 hours and the results tabulated in Figures 8 and 9. The program predicted condensate with no ice accumulation on all TPS acreage surfaces.

Very light condensate, but no ice or frost, was present on the -Z side of the LO2 tank. The +Z side of the tank was dry. There were no TPS anomalies. The tumble valve cover was intact. The STI IR scanner measured an average surface temperature of 60 degrees F on the ogive and 50 degrees F on the barrel section, compared to a SURFICE prediction of 50 degrees and a Mikron IR gun measurement of 52 degrees F on the barrel section.

Light run-on condensate was present on the intertank -Z side. There were no TPS anomalies. Small frost spots had accumulated in 5 stringer valleys at the LO2 tank-to-intertank flange and in 13 stringer valleys at the LH2 tank-to-intertank flange. Both locations were on the -Z side of the tank. The STI IR scanner measured an average surface temperature of 65 degrees compared to a range of 57-65 degrees F measured by the Mikron IR gun. Some frost had formed around the GUCP, but there was no sign of leakage.

A light amount of condensate trickled down the LH2 tank and ran off the aft dome. There was no acreage ice/frost and no TPS anomalies. The average surface temperature as measured by the STI IR scanner was 54 degrees F, compared to 53 degrees F measured by the Mikron IR gun and 51 degrees F predicted by the SURFICE computer program.

Small frost spots 3/4-inch in diameter had formed around both bipod DFI box drain holes. There was very minor outgassing from the holes. This was not an IPR condition.

Frost spots formed along the aft interfaces of 6 ice/frost ramps. A frost spot 1 inch in diameter was visible in the -Y longeron-to-thrust strut interface. The +Y ET/SRB cable tray microphone and vent hole were covered by frost.

Ice/Frost covered the lower EB fittings outboard to the strut pin hole with condensate on the rest of the fitting. The struts were dry and were not covered by ice.

STS- 31R		TEST S0007 LAUNCH				DATE: 23 April 1990		T-0 TIME 08:33:51																
ORBITER 103		ET 34	SRB BI-037	MLP 2	PAD B	LO2		LH2																
		CHILLDOWN TIME: 00:01		FAST FILL TIME: 00:38		CHILLDOWN TIME: 23:49		FAST FILL TIME: 00:28																
		SLOW FILL TIME: 00:26		REPLENISH TIME: 02:43		SLOW FILL TIME: 23:59		REPLENISH TIME: 02:25																
		CONDITIONS				LH2 TANK STA 1130 TO 1380				LH2 TANK STA 1380 TO 2058														
TIME (EDT)	TEMP F	REL. HUM. %	DEW PT F	WIND VEL KNTS	WIND DIR DEG	LOCAL VEL KNTS	SOFI TEMP	COND RATE IN/HR	ICE RATE IN/HR	REG	LOCAL VEL KNTS	SOFI TEMP	COND RATE IN/HR	ICE RATE IN/HR	REG	LOCAL VEL KNTS	SOFI TEMP	COND RATE IN/HR	ICE RATE IN/HR					
0030	71.60	72.40	62.52	14	80	8.26	61.31	0.0009	-0.2453	II	8.26	58.42	0.0029	-0.2142	II	7.70	57.43	0.0033	-0.1940	II	17.08	61.35	0.0017	-0.4356
0045	71.80	72.60	62.80	11	81	6.49	60.71	0.0013	-0.2001	II	6.49	57.20	0.0031	-0.1697	II	6.05	56.00	0.0035	-0.1524	II	13.42	60.65	0.0025	-0.3462
0100	71.40	73.00	62.56	13	86	7.67	61.00	0.0011	-0.2290	II	7.67	57.93	0.0030	-0.1981	II	7.15	56.87	0.0034	-0.1790	II	15.86	61.02	0.0021	-0.4037
0115	71.40	72.40	62.33	12	77	7.08	60.57	0.0011	-0.2118	II	7.08	57.28	0.0030	-0.1813	II	6.60	56.16	0.0034	-0.1632	II	14.64	60.56	0.0022	-0.3702
0130	71.60	71.40	62.14	12	74	7.08	60.54	0.0010	-0.2115	II	7.08	57.25	0.0029	-0.1809	II	6.60	56.13	0.0033	-0.1629	II	14.64	60.51	0.0020	-0.3693
0145	71.40	71.00	61.78	11	80	6.49	59.91	0.0011	-0.1931	II	6.49	56.37	0.0029	-0.1629	II	6.05	55.17	0.0033	-0.1461	II	13.42	59.85	0.0022	-0.3338
0200	71.20	71.20	61.67	12	80	7.08	60.08	0.0010	-0.2072	II	7.08	56.77	0.0029	-0.1768	II	6.60	55.64	0.0033	-0.1590	II	14.64	60.06	0.0019	-0.3619
0215	71.20	70.80	61.51	13	77	7.67	60.27	0.0009	-0.2216	II	7.67	57.17	0.0028	-0.1910	II	7.15	56.11	0.0032	-0.1723	II	15.86	60.28	0.0016	-0.3904
0230	71.00	70.40	61.15	11	74	6.49	59.36	0.0010	-0.1883	II	6.49	55.79	0.0029	-0.1583	II	6.05	54.58	0.0032	-0.1417	II	13.42	59.29	0.0020	-0.3254
0245	70.80	69.40	60.56	12	75	7.08	59.24	0.0008	-0.1994	II	7.08	55.90	0.0027	-0.1693	II	6.60	54.76	0.0031	-0.1520	II	14.64	59.21	0.0016	-0.3480
0300	71.00	69.40	60.76	13	81	7.67	59.73	0.0007	-0.2163	II	7.67	56.61	0.0026	-0.1858	II	7.15	55.54	0.0030	-0.1674	II	15.86	59.73	0.0013	-0.3807
0315	70.80	69.00	60.40	14	73	8.26	59.68	0.0005	-0.2281	II	8.26	56.74	0.0024	-0.1975	II	7.70	55.73	0.0029	-0.1764	II	17.08	59.70	0.0009	-0.4045
0330	70.60	68.80	60.12	11	82	6.49	58.56	0.0009	-0.1815	II	6.49	54.97	0.0027	-0.1517	II	6.05	53.74	0.0030	-0.1355	II	13.42	58.49	0.0017	-0.3134
0345	70.40	67.20	59.28	12	67	7.08	58.30	0.0006	-0.1909	II	7.08	54.93	0.0024	-0.1610	II	8.40	55.41	0.0025	-0.1871	II	14.52	58.23	0.0012	-0.3300
0400	70.20	67.60	59.24	12	73	7.08	58.20	0.0006	-0.1601	II	7.08	54.82	0.0024	-0.1440	II	6.60	53.66	0.0028	-0.1434	II	14.64	58.16	0.0012	-0.3313
0415	70.00	67.40	58.97	11	70	6.49	57.61	0.0007	-0.1736	II	6.49	53.98	0.0025	-0.1440	II	6.05	52.74	0.0029	-0.1283	II	13.42	57.54	0.0015	-0.2995
0430	70.60	66.80	59.31	11	66	6.49	58.08	0.0007	-0.1774	II	6.49	54.46	0.0024	-0.1477	II	7.70	54.96	0.0026	-0.1715	II	13.31	57.95	0.0014	-0.3034
0445	70.20	66.40	58.75	11	77	6.49	57.58	0.0006	-0.1732	II	6.49	53.94	0.0024	-0.1437	II	6.05	52.71	0.0028	-0.1280	II	13.42	57.49	0.0013	-0.2987
0500	70.80	66.20	59.25	9	71	5.31	57.32	0.0009	-0.1487	II	5.31	53.08	0.0025	-0.1196	II	4.95	51.68	0.0029	-0.1055	II	10.98	57.08	0.0018	-0.2496
0515	70.60	66.80	59.31	11	73	6.49	58.08	0.0007	-0.1774	II	6.49	54.46	0.0024	-0.1477	II	6.05	53.24	0.0028	-0.1318	II	13.42	57.99	0.0014	-0.3060
0530	70.40	66.20	58.86	12	70	7.08	58.06	0.0005	-0.1887	II	7.08	54.68	0.0023	-0.1589	II	6.60	53.52	0.0027	-0.1423	II	14.64	58.01	0.0009	-0.3288
0545	70.40	65.40	58.52	10	74	5.90	57.16	0.0007	-0.1587	II	5.90	53.23	0.0024	-0.1294	II	5.50	51.92	0.0027	-0.1147	II	12.20	57.00	0.0014	-0.2701
0600	70.20	65.00	58.16	10	63	5.90	56.86	0.0006	-0.1564	II	5.90	52.91	0.0023	-0.1272	II	7.00	53.43	0.0025	-0.1475	II	12.10	56.66	0.0014	-0.2638
0615	70.40	65.40	58.52	9	63	5.31	56.71	0.0008	-0.1444	II	5.31	52.45	0.0024	-0.1154	II	6.30	52.98	0.0026	-0.1336	II	10.89	56.43	0.0017	-0.2401
0630	70.00	66.40	58.55	7	49	4.13	55.37	0.0011	-0.1145	II	4.13	50.20	0.0026	-0.0961	II	4.90	50.76	0.0028	-0.0993	II	8.47	54.84	0.0024	-0.1828
0645	70.60	66.60	59.22	8	72	4.72	56.69	0.0010	-0.1333	II	4.72	52.05	0.0026	-0.1044	II	4.40	50.54	0.0029	-0.0913	II	9.76	56.35	0.0022	-0.2197
0700	71.00	67.60	60.03	9	54	5.31	57.87	0.0010	-0.1527	II	5.31	53.65	0.0027	-0.1234	II	6.30	54.17	0.0029	-0.1426	II	10.89	57.60	0.0021	-0.2543
0715	71.60	65.40	59.70	10	72	5.90	58.38	0.0007	-0.1681	II	5.90	54.50	0.0024	-0.1385	II	5.50	53.22	0.0028	-0.1233	II	12.20	58.20	0.0014	-0.2861

FIGURE 8. Ice/Frost Computer Predictions



There were no anomalies on the aft dome apex or manhole covers.

Normal amounts of hard ice were present in all LO2 feedline bellows. Slightly less than usual amounts of ice/frost were present in the LO2 feedline support brackets. There was no ice/frost at the LO2 feedline attach bracket to the crossbeam due to a non-functioning heater. (An approved modification had disconnected and capped the heater cables). Appendix F of the LCC had been modified to accept 22 square inches of ice in this area per a Level II Change Request. The LO2 ET/ORB umbilical exhibited typical (light) ice/frost accumulations on the aft and inboard sides. Frost fingers had formed on the purge vents.

There was the usual amount of ice in the LH2 feedline bellows. A 2-inch frost line had formed on the +Y side of the -Z bellows (feedline to bellows shield interface). A normal amount of ice had formed in the LH2 recirculation line bellows and burst disks.

The LH2 ET/ORB umbilical exhibited the usual accumulation of ice on the outboard side. Ice on top of the umbilical was thinner but extended farther. A frost line had formed along the outboard bracket and around the feedline-to-umbilical interface. Frost fingers had formed on the purge vents and normal venting was occurring. There was no evidence of cold gas venting or frost around the umbilical aft vent holes.

IPR 31RV-0180 was taken for helium purge gas leaking out of the flapper valve actuator torque tool port closeout, which consists of a PDL foam plug sealed with epoxy-resin. The leak originated from a crack in the MBO-130-136 polyurethane resin sealant at the upper outboard corner, near the LH2 feedline. Low density frost 10"x10"x1" covered the plug and surrounding area. The IPR was upgraded to PR ET-34-TS-0045 and dispositioned with MRB approval to use-as-is. This area was not one of the LCC ice acceptance areas/NSTS-08303 and was waived per LW021 (ref PRCB 570957L)

The summary of ice/frost team observation anomalies consists of 10 OTV recorded items:

Anomaly 001 documented ice/frost formation on the aft side of the cable tray ramps at stations 1528, 1657, and 2034. This condition was acceptable per NSTS-08303.

Anomaly 002 recorded ice/frost accumulations and vapors in the area of the umbilical separation bolt catcher purge vent, the umbilical baggie, and the closeout lines. IPR 31RV-0180, upgraded to PR ET-34-TS-0045, was taken to accept ice/frost formation on the aft side of the LH2 feedline caused by leaking cavity helium purge gas from the upper right corner of the pre-formed TPS plug (ref LCC waiver LW021 PRCB 570957L. Ice/frost in the other areas were acceptable per NSTS-08303.



An ice/frost spot formed at an intertank stringer root, first 6 valleys to the -Z side of the -Y thrust panel at the LO2 tank-to-intertank flange closeout. This was acceptable per NSTS-08303 (Anomaly 003).

Anomaly 004 documented ice/frost and vapors in both bipod DFI box drain holes. The T-3 hour inspection revealed only frost without run-on moisture in the drain holes.

Anomaly 005 recorded ice/frost accumulations in the LO2 feed-line support brackets at stations 1377, 1623, and 1871. These accumulations were acceptable per NSTS-08303.

The TPS crack filled with ice/frost in both the +Y and -Y longeron-to-thrust strut interfaces was acceptable per NSTS-08303 (Anomaly 006).

Anomaly 007 documented ice/frost formation on the +Y ET/SRB cable tray DFI instrumentation. This condition was acceptable per NSTS-08303.

Anomaly 008 recorded ice/frost accumulations in the LO2 feed-line support brackets, the LO2 feedline bellows, the LH2 feed line bellows, and the LH2 recirculation line bellows. All of these areas were acceptable per NSTS-08303.

Ice/frost formations on the LO2 ET/ORB umbilical purge vents, baggie, and acreage areas were acceptable per NSTS-08303 (Anomaly 009).

Anomaly 010 documented ice/frost at the shipping strut attach point, an acceptable accumulation per NSTS-08303.

## 5.5 FACILITY OBSERVATIONS

All debris concerns previously identified had been resolved prior to cryoloading. The only new debris item found during the inspection was a safety rope spanning two stanchions on the FSS 115 foot level. The rope was removed by the Ice Team.

The SRB sound suppression water troughs were full. No leaks were observed on either the LO2 or LH2 ORB T-0 umbilicals, though small amounts of ice had formed. Some condensate dripped from the LO2 TSM umbilical. There was no apparent leakage anywhere on the GH2 vent line or GUCP. Some ice/frost, which was expected, had accumulated on the GUCP legs. Visual and infrared observations of the GOX seals confirmed no leakage. The ends of the GOX vent ducts exhibited no frost or icicles.

The ET/ORB hydrogen detection sensor tygon tubing was removed with no damage to the vehicle. However, the outboard tube had drooped close enough to the umbilical for ice to form around and in the end of the tube to a depth of 1-1/2 inches.



Prelaunch condition of ET tumble valve cover

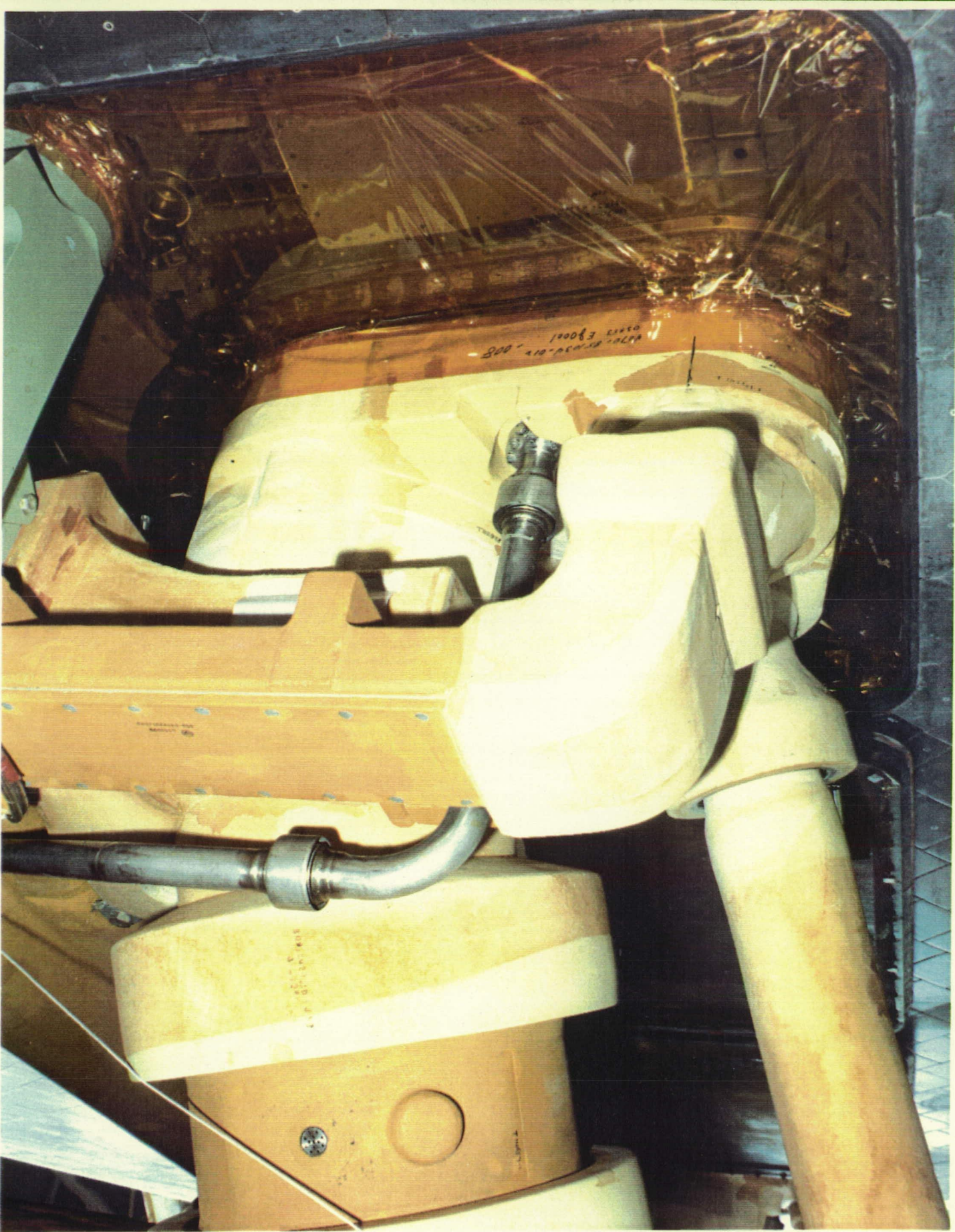

LH2 ET/ORB umbilical prior to second cryo-load. Cord in upper left corner is attached to hydrogen detection system tygon tube

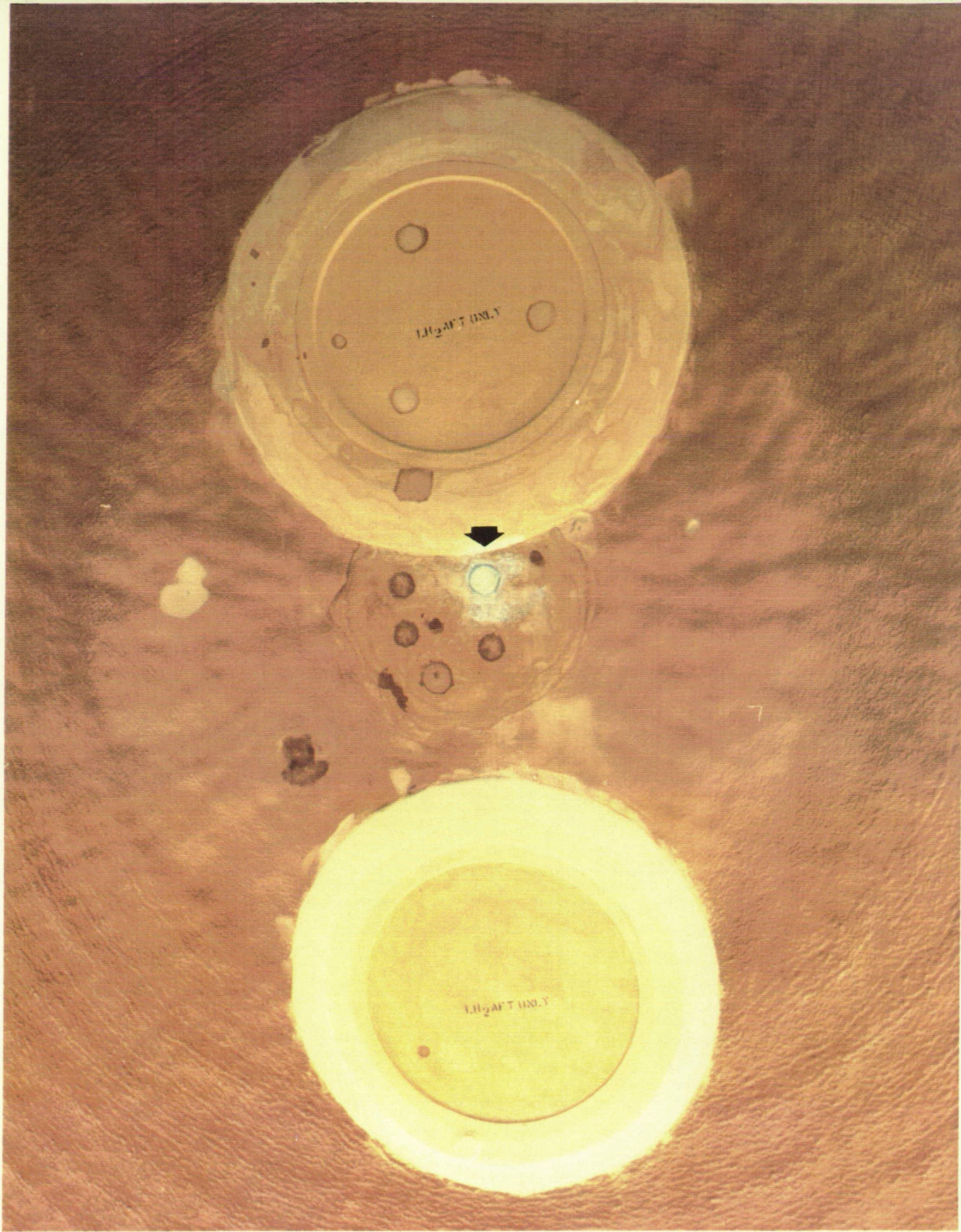

3-inch diameter repair on the ET aft dome apex fell out after drain and was repaired prior to the second cryo-load



No acreage ice/frost had formed on the -Y+Z side of the tank

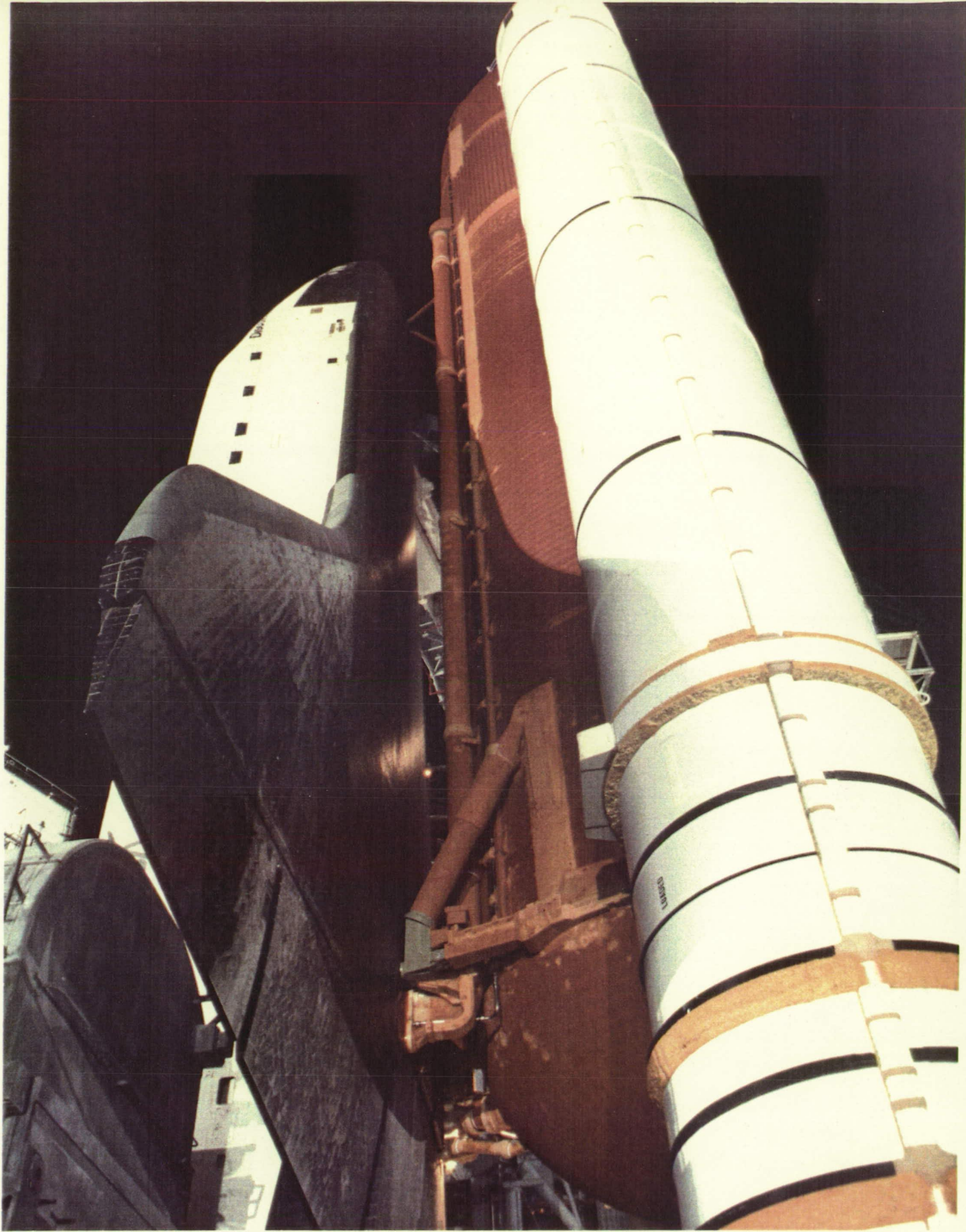

No acreage ice/frost had formed on the +Y+Z side of the tank

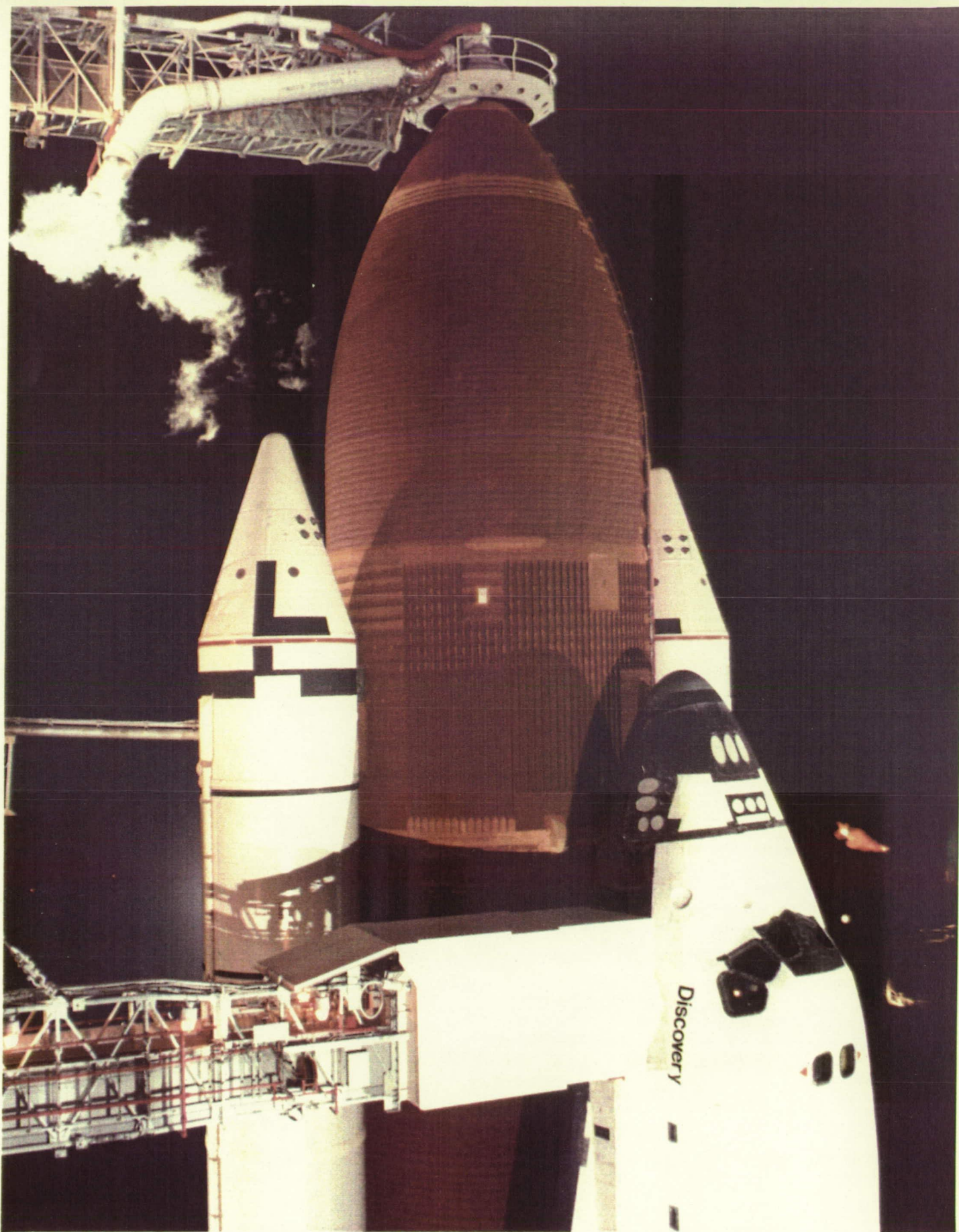

There was no ice/frost accumulation on the LO2 tank ogive or barrel section. GOX duct vapors were not near the vehicle.

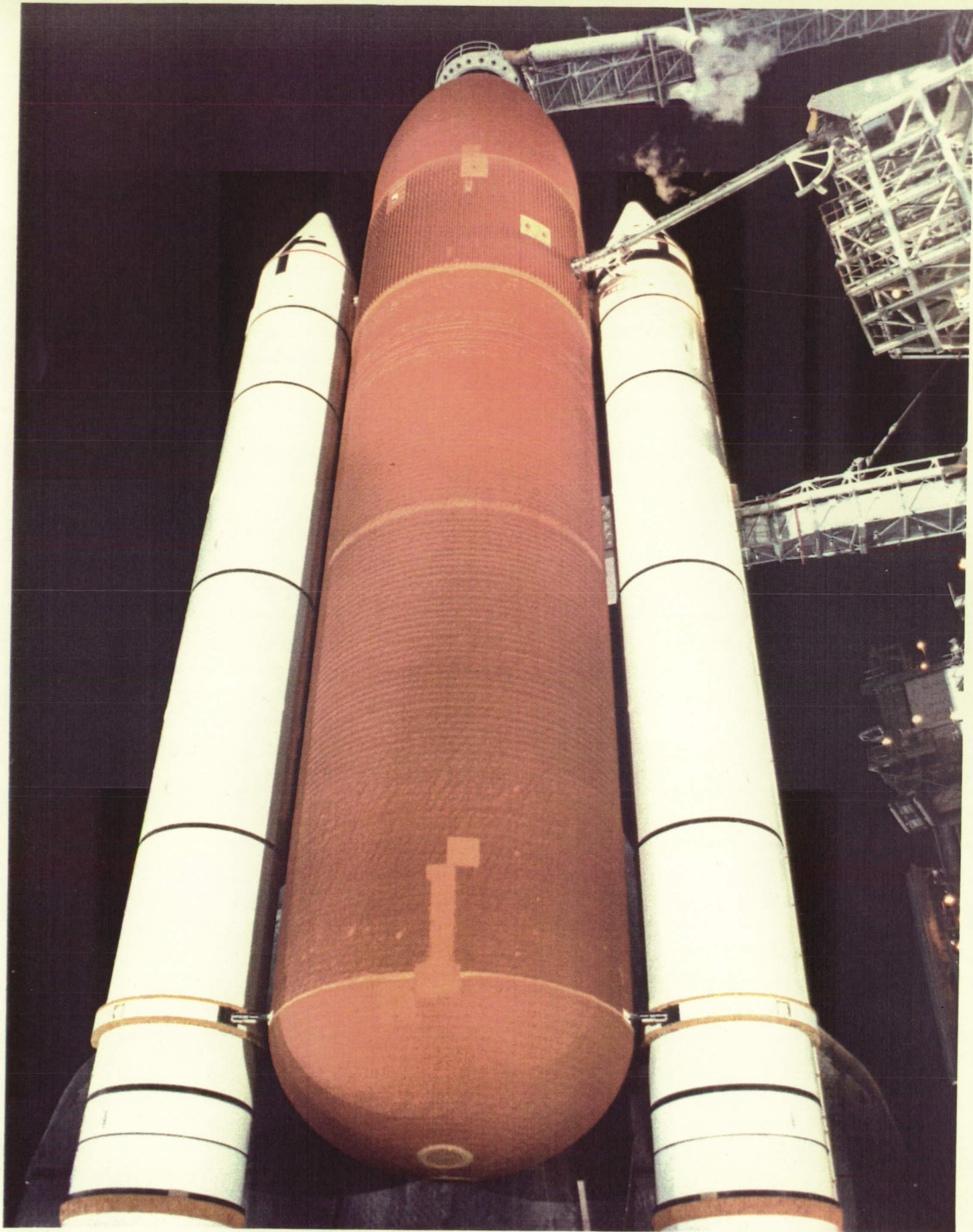

Overall view of ET-34 -Z side. There were no acreage TPS defects or anomalies



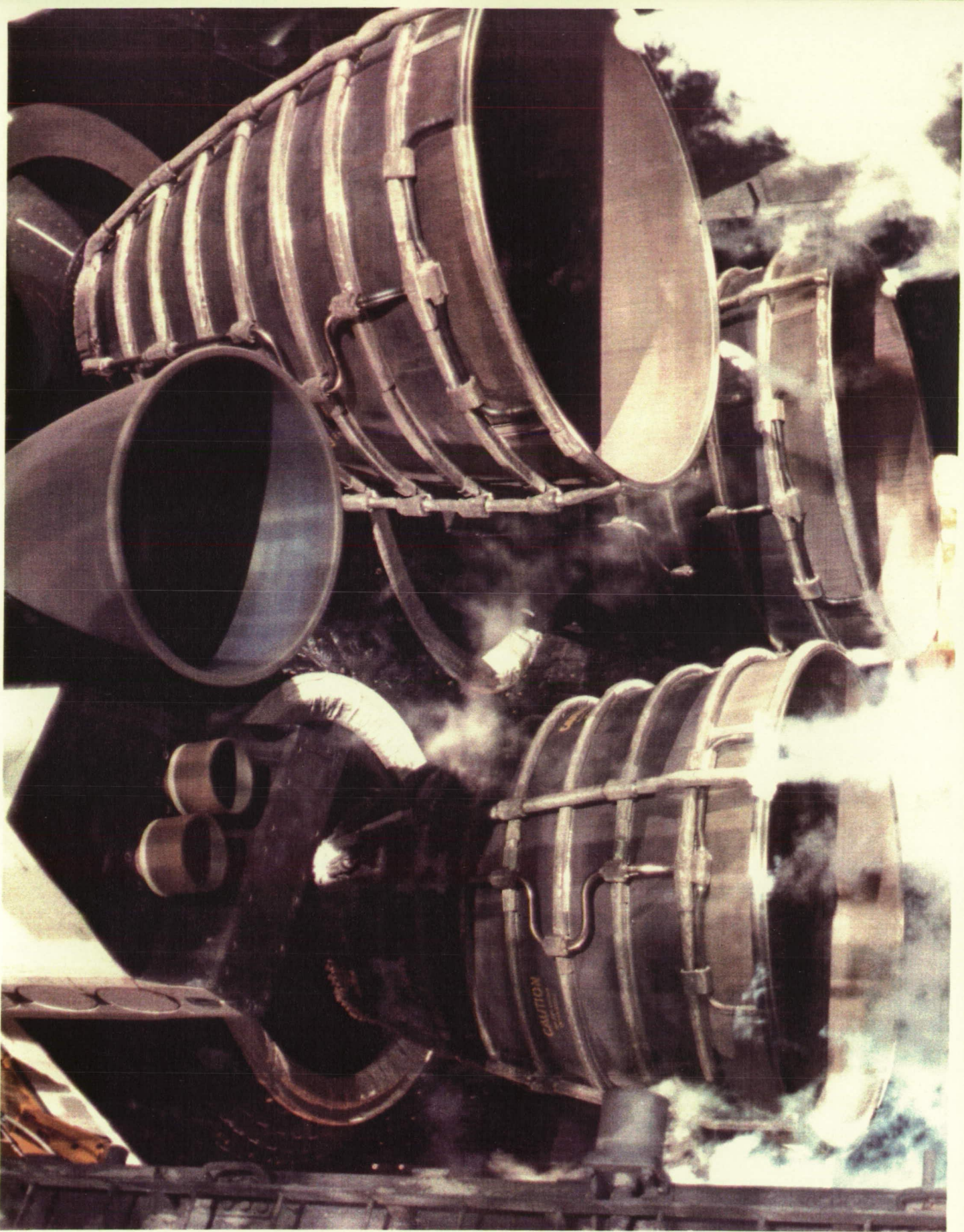

Overall view of SSME's. Note appearance of ice/frost at the SSME #2 engine mounted heat shield interface.

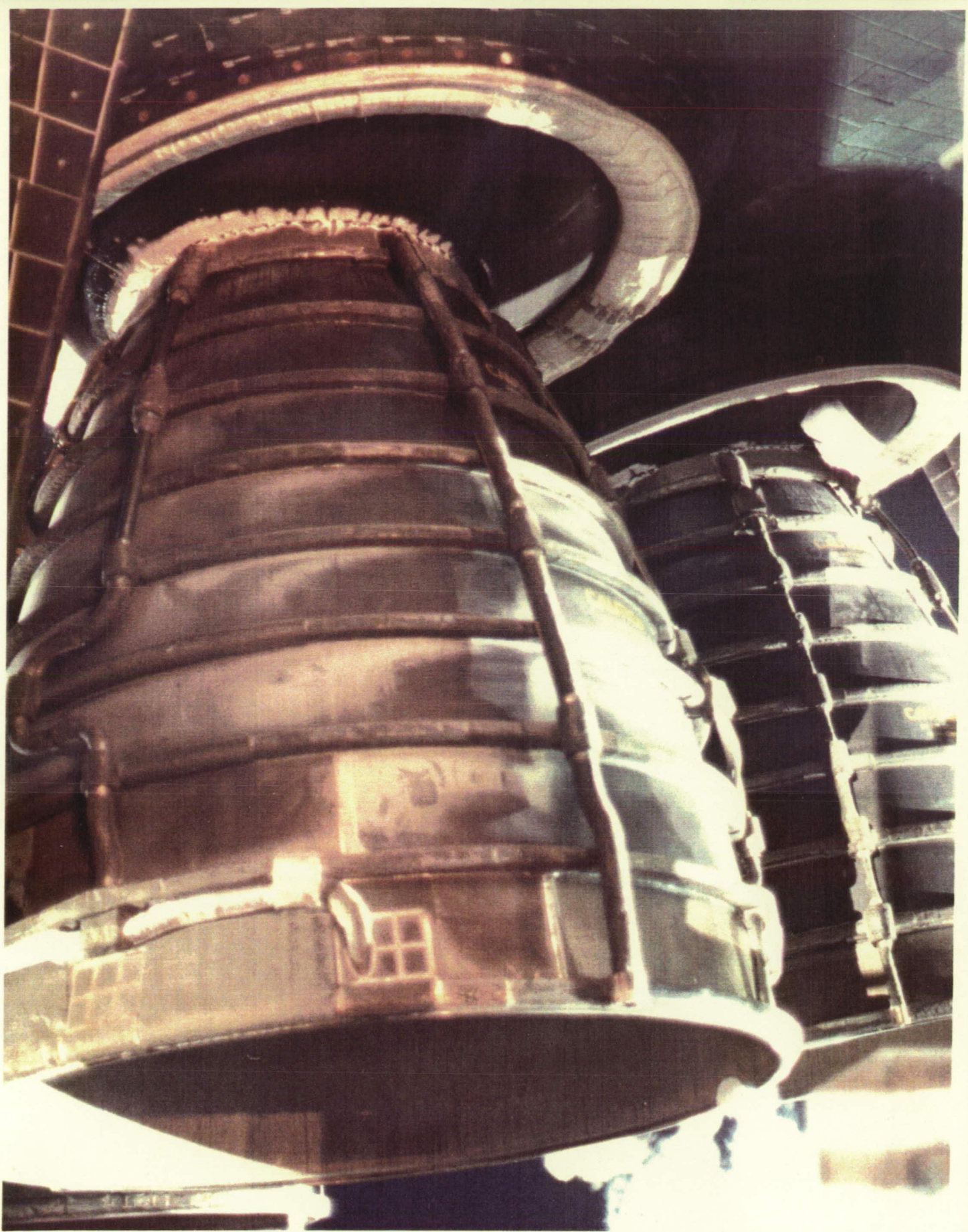

Typical ice/frost has formed at the SSME #1 and #2  
nozzle to engine mounted heat shields



Frost accumulations in the intertank stringer valleys occurred on the -Z side of the tank

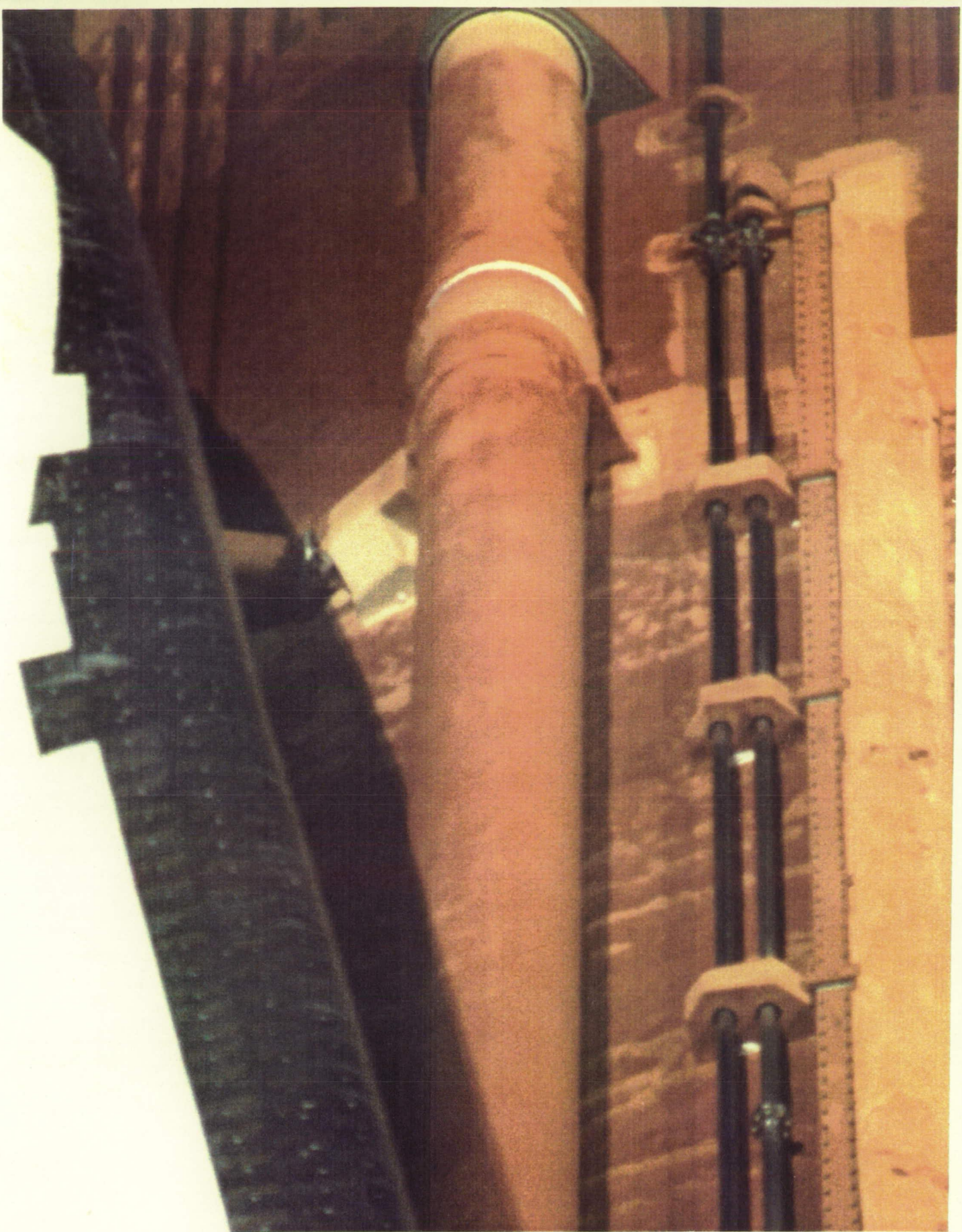

Typical amount of ice formed in the L02 feedline upper bellows.  
Ice/frost also formed along aft sides of the ice/frost ramps.



Typical accumulation of ice/frost in the L02 feedline support bracket. Note frost spot along aft side of ice/frost ramp.



Normal appearance of ice/frost on the purge vents and aft side of the LO2 ET/ORB umbilical. Cable tray vent hole is clear.

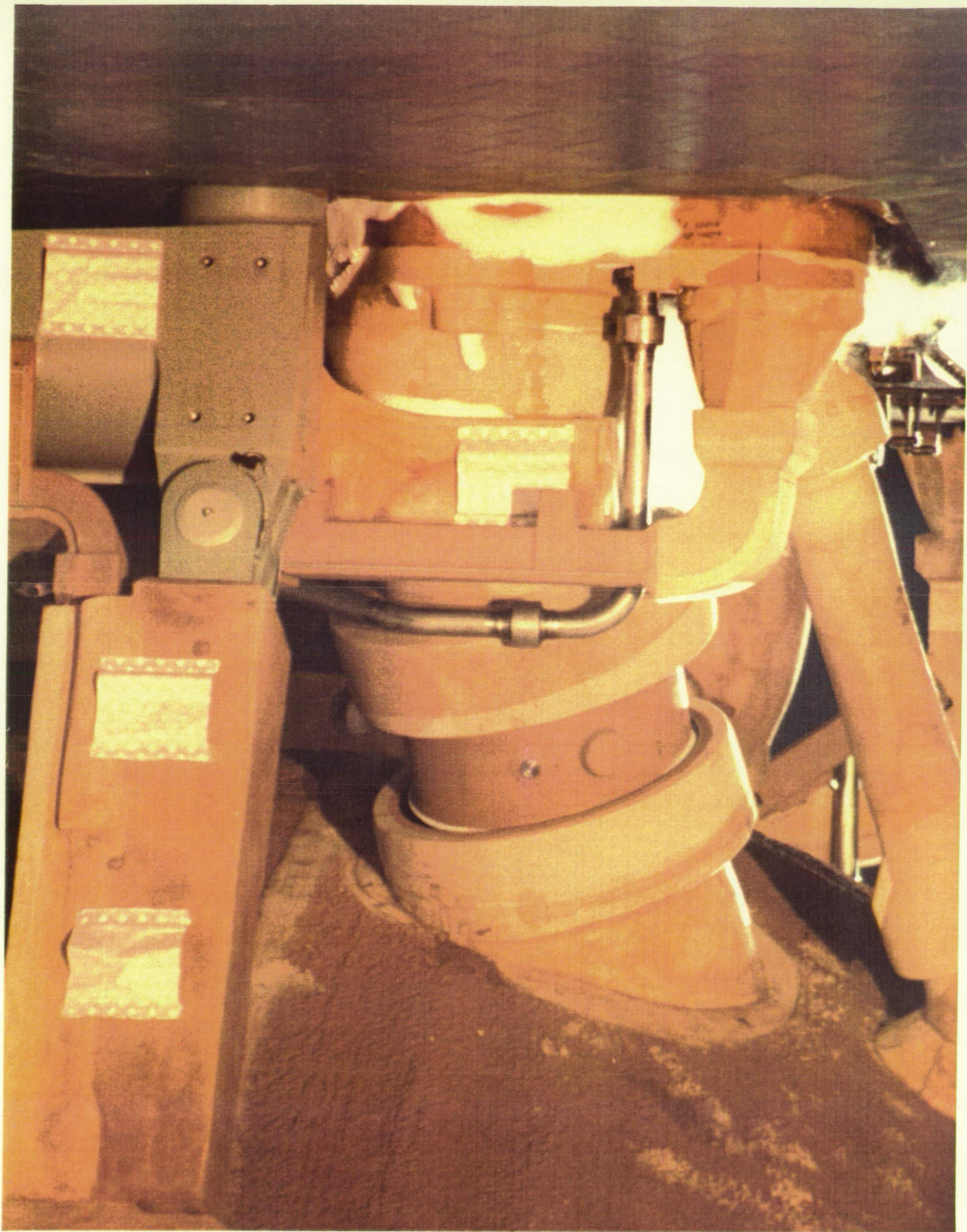

Overall view of LH2 ET/ORB umbilical. Venting of purge gas from the inboard purge vents is a normal occurrence.



Ice/frost has formed on the purge vents, around the LH2 feedline, and on the top and side of the LH2 umbilical



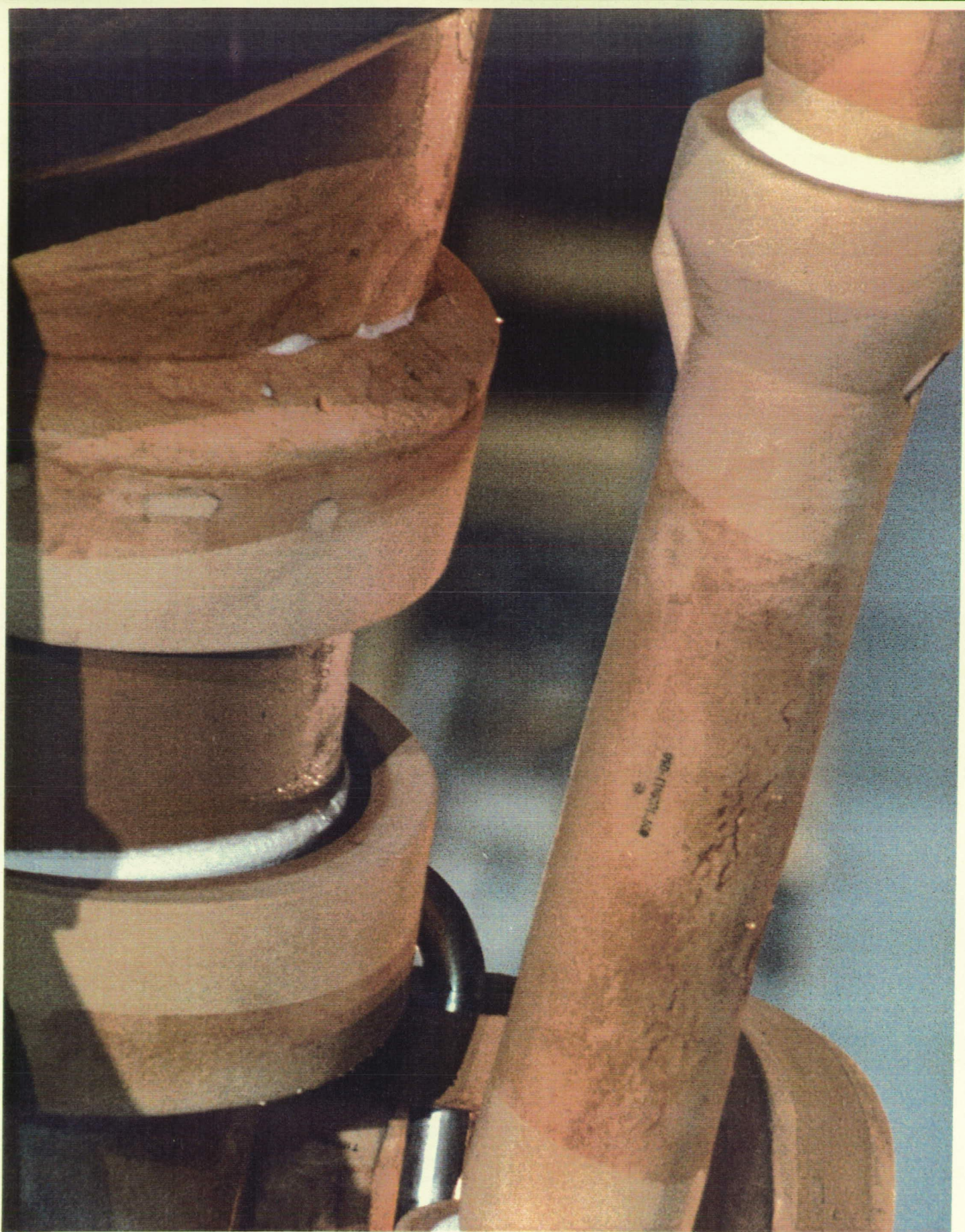

Ice/frost in the LH2 feedline and recirculation line bellows is normal. Two frost spots formed on the F/L flange closeout.

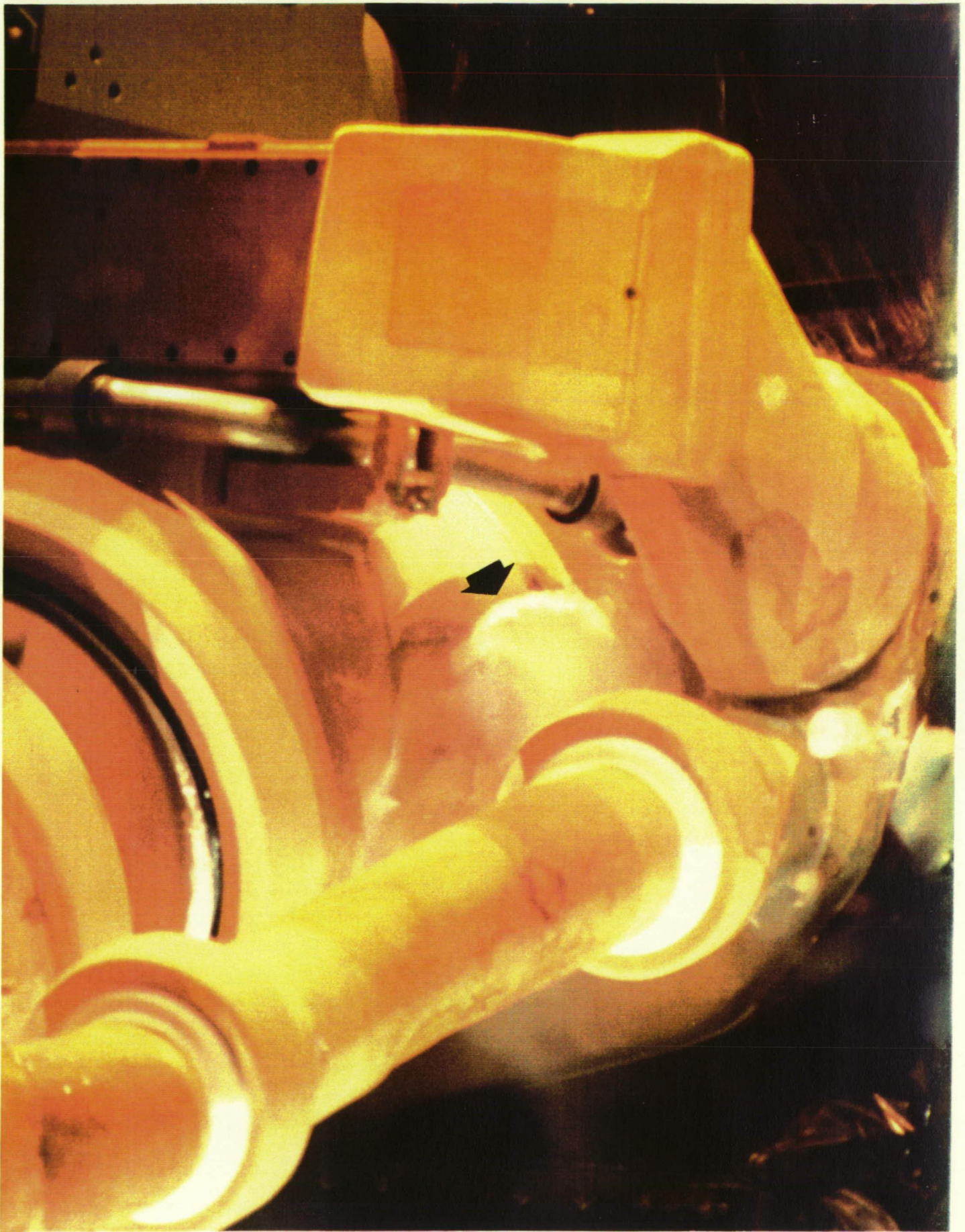

An LCC waiver was granted for the 10"x10"x1" ice/frost covering the flapper valve actuator port PDL plug closeout

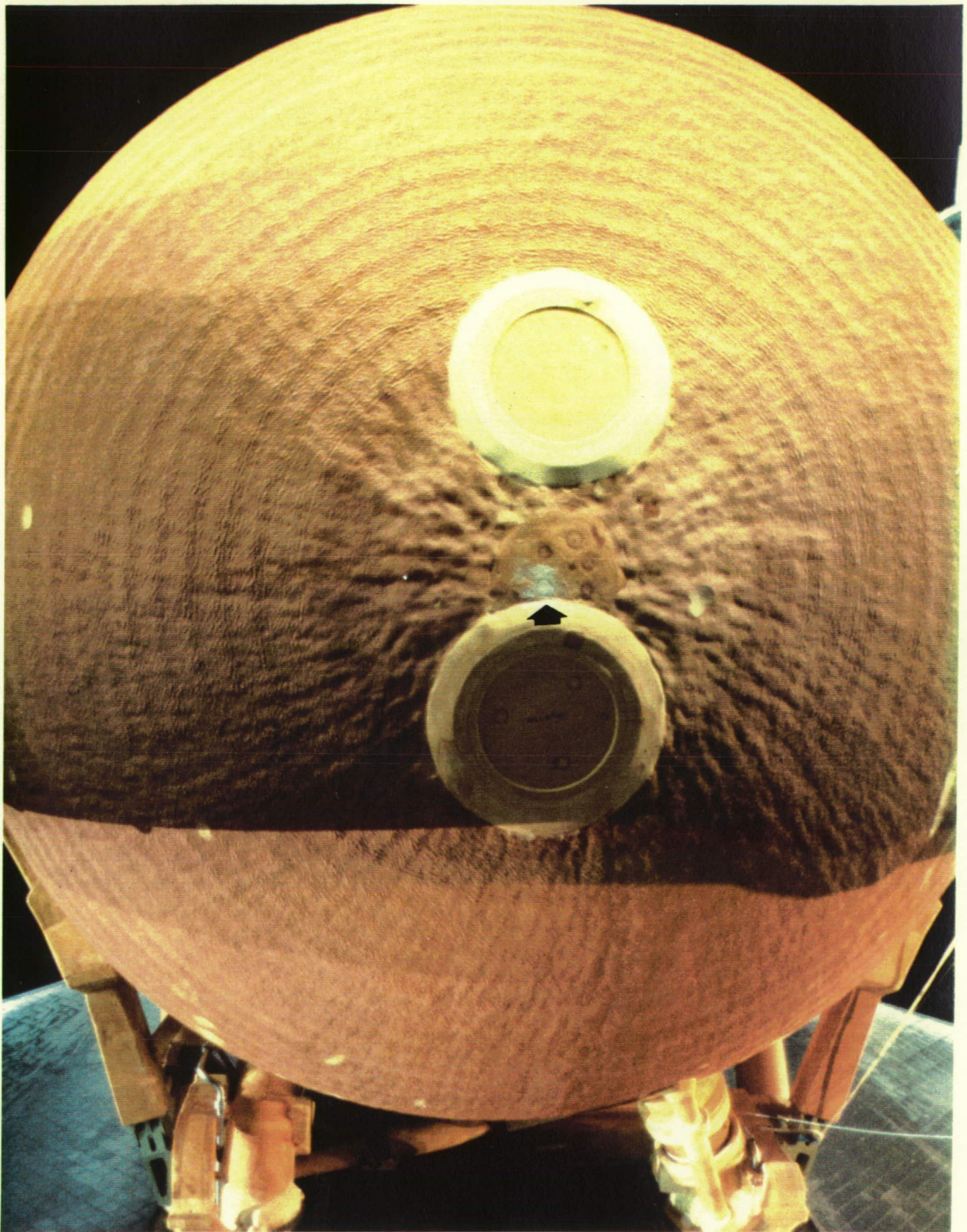

No TPS defects or anomalies occurred on the ET aft dome. No frost formed on the 3-inch diameter apex repair.



The hydrogen detection system tygon tubing drooped and became plugged when ice formed on top of the LH2 ET/ORB umbilical

## 6.0 POST LAUNCH PAD DEBRIS INSPECTION

The post launch inspection of the pad and surrounding area was conducted on 24 April 1990 from launch + 2 to 6 hours. The MLP, FSS, pad apron, and acreage areas were inspected. No flight hardware or TPS materials were found. The usual SRB throat plug material (foam and RTV) was found. Water trough material from the SRB exhaust holes was scattered through the field and on the pad apron.

The SRB holddown post erosion was normal. All south holddown post shim material was intact, but was 100 percent debonded on HDP #1 and #2. Slight debonding of the sidewall shim material occurred on HDP #5 and #6. All of the doghouse blast covers on the north holddown posts were in the closed position and exhibited slightly more than normal erosion. The HDP #4 blast cover had a 1-inch diameter hole adjacent to a 1-1/2 inch long crack near the center of the cover. The south inboard corners of HDP #4 and #8 had eroded away approximately 1 inch. The SRB aft skirt purge lines were in place and slightly damaged. The SRB joint heater T-0 umbilicals showed minor damage.

The normal amount of facility debris was found. The most significant debris consisted of three metal cable tray covers, the largest of which measured 2 feet by 5 feet, found on the pad apron near the RSS park position, on the pad apron in front of the elevator doors, and on the FSS 135 foot level hanging from the overhead grating. In addition, an unidentified metal plate 12 inches square lay on the southwest slope of the pad apron.

The GOX vent arm, Orbiter access arm, and TSM's showed the normal amount of damage. The GH2 vent arm was latched on the 8th tooth of the latching mechanism and had no loose cables. It showed typical signs of SRB plume heating. The GH2 vent arm appeared to have retracted nominally, with the exception of the north latch contacting and riding against the north saddle stabilizer. This has occurred on previous launches.

All seven emergency egress slidewire baskets were secured on the FSS 195 foot level and sustained no launch damage.

Overall, there was very little damage to the launch pad.

Patrick AFB and MILA radars were configured in a mode for increased sensitivity for the purpose of observing any debris falling from the vehicle during ascent but after SRB separation (due to the masking effect of the SRB exhaust plume). Although most of the signal registrations were very weak and often barely detectable, which generally compares with the types of particles detected on previous Shuttle launches, a total of 52 particles were imaged in the T+149 to 370 time period. Twenty-

five of the particles were imaged by only 1 radar, 16 particles were imaged by two radars, and 11 particles were imaged by all 3 radars.

However, a point of interest includes the SRB plume echoes and "chunk" departures registered during the launch phase until SRB separation. Some particles in this time frame were tracked at velocities greater than 1000 m/s and could be chunks of SRB propellant with associated propulsive force. Other particles were measured at 450 m/s, which is more characteristic of particles detected when the ET/ORB combination is clearly separated from the SRB's and may be TPS type materials.

The debris inspection continued on 25 April 1990 and was expanded to include areas outside the pad perimeter fence. Ground teams searched the beach, railroad tracks, and the beach road from the northern KSC boundary to the Titan complex. The NASA helicopter was utilized to cover the water areas around the pad, the beach from UCS-10 to the lighthouse, and the ocean area under the flight path. No flight hardware from this launch vehicle was found.

Post Launch Pad Debris Inspection Anomalies are listed in Section 11.1.

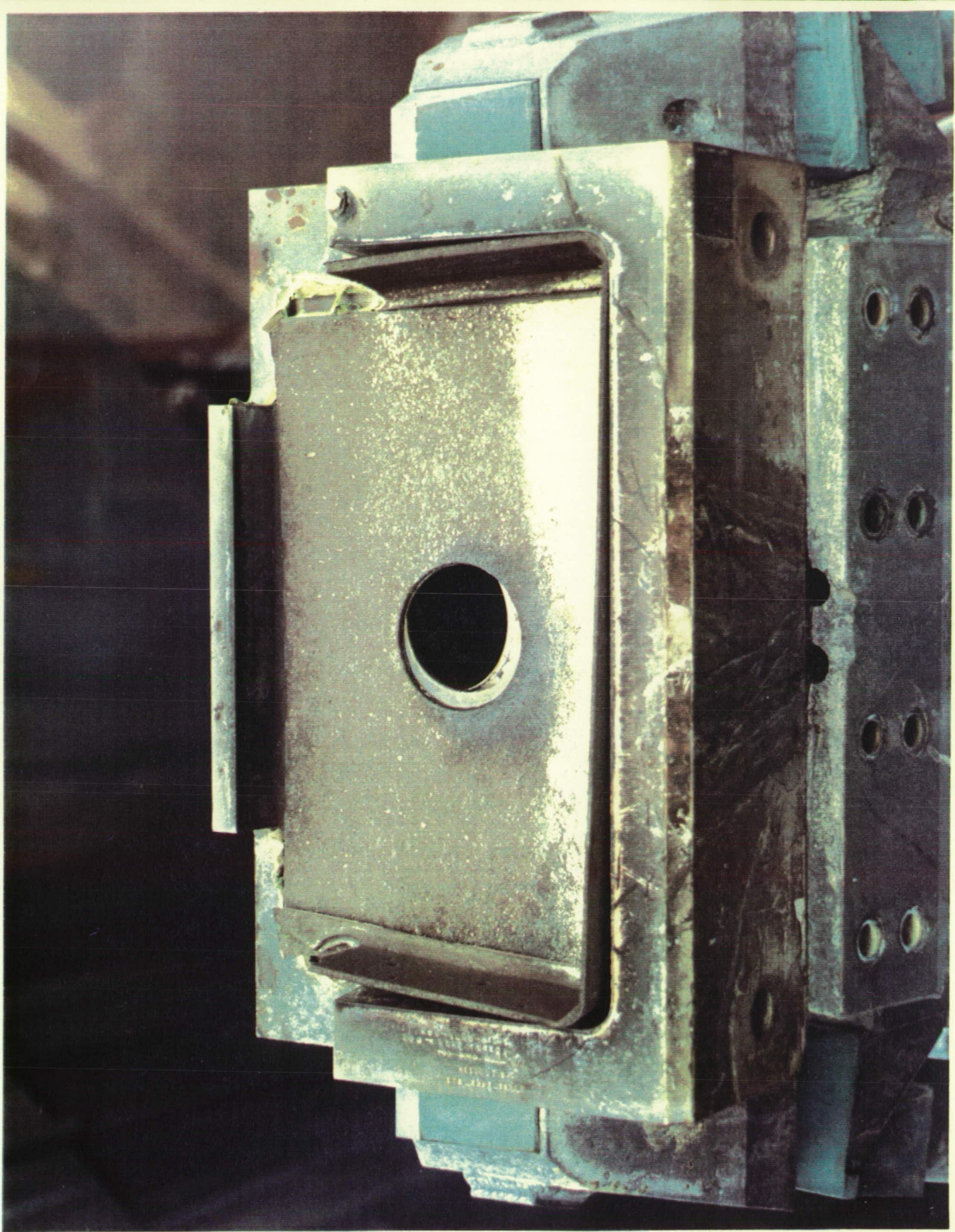

HDP #1 Epon shim material was 100 percent debonded

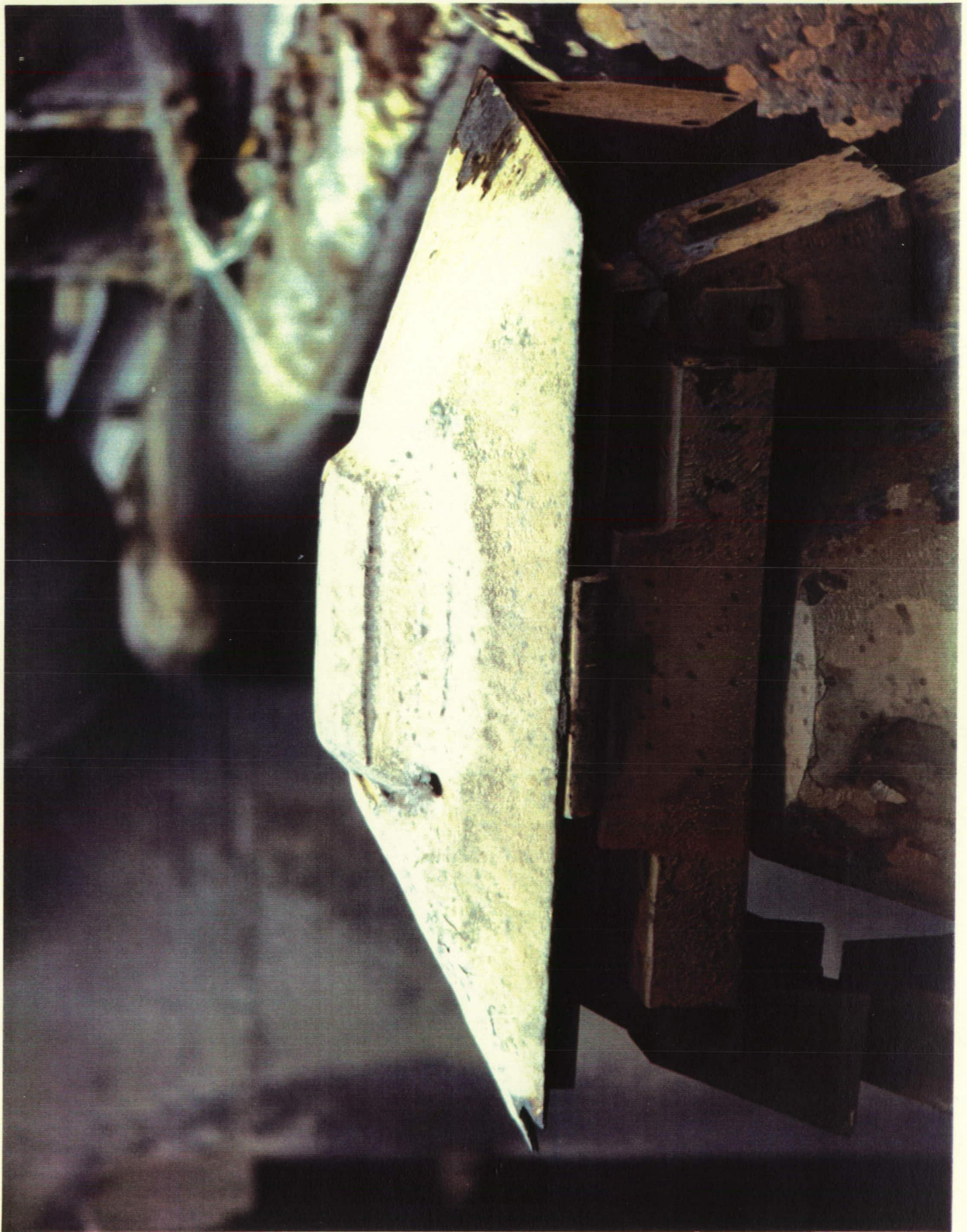

The SRB plume caused erosion (center and corner) and a 1.5 inch crack in the HDP #4 doghouse blast cover



## 7.0 FILM REVIEW SUMMARY/PROBLEM REPORT DISPOSITION

A total of 123 film and video data items, which included 34 videos, 52 16mm films, 31 35mm films, and 6 70mm films, were reviewed starting on launch day.

No major vehicle damage or lost flight hardware was observed that would have affected the mission.

SSME ignition acoustics/vibration caused a 2-1/2"x1" tile chip to fall from the trailing edge (RH side) of the rudder speed brake (E-2, 76, 78) and small pieces of tile surface coating material to shake loose from the base heat shield between SSME #1 and #3 (E-23). A heavy shower of ice/frost particles from the ET/ORB LH2 and LO2 umbilicals fell past the body flap during SSME ignition, but no tile damage was visible (E-5, 6, 26). Five ice particles, probably from the LO2 feedline upper bellows or support bracket, fell between the tank and orbiter. One particle, 2 inches long, contacted the LH wing aft of the RCC. The particle broke into two pieces and changed direction at the point of contact. No tile damage was visible (E-34, 35, 36).

A parts tag dropped from the LH2 T-0 umbilical fluid lines just after separation (E-18, 20). One Q-felt plug fell from the aft edge of LH RCS stinger (E-24).

Five pieces of SRB aft skirt instafoam broke loose near HDP #7. The first piece originated from the HDP shoe corner and one 1.5" long piece of instafoam came from the sanded area near the aft skirt foot. Small pieces of instafoam broke loose near HDP #5 (EX-4, E-11).

No debris was visible falling from holddown posts #2 through #8 after liftoff. However, a 3.5"x0.25" ordnance debris fragment dropped from the RH SRB HDP #1 stud hole (E-9). There was no sign of holddown post stud hang-ups in any of the films.

Vehicle twang was normal. ET nose cone spike excursion is shown in Figure 10.

Aft RCS paper covers, which are pulled into the SSME plume by aspiration, fell from the vehicle at T-0 and through early ascent. Forward RCS covers began to detach just prior to the roll program and continued through ascent (E-52, 53, 54, 62, 64, 201, 202, 207, 213, 220, 222).

There were no major facility anomalies. No swing arms or other pad structures contacted the vehicle during liftoff. The GH2 vent line latched properly, but excessive slack in the static retract lanyard created a loop of cable that contacted the GUCP (E-42). There was no visible evidence of damage to the GUCP.

FIGURE 10. Optical Position Data

ET Nose Spike Northern Movement

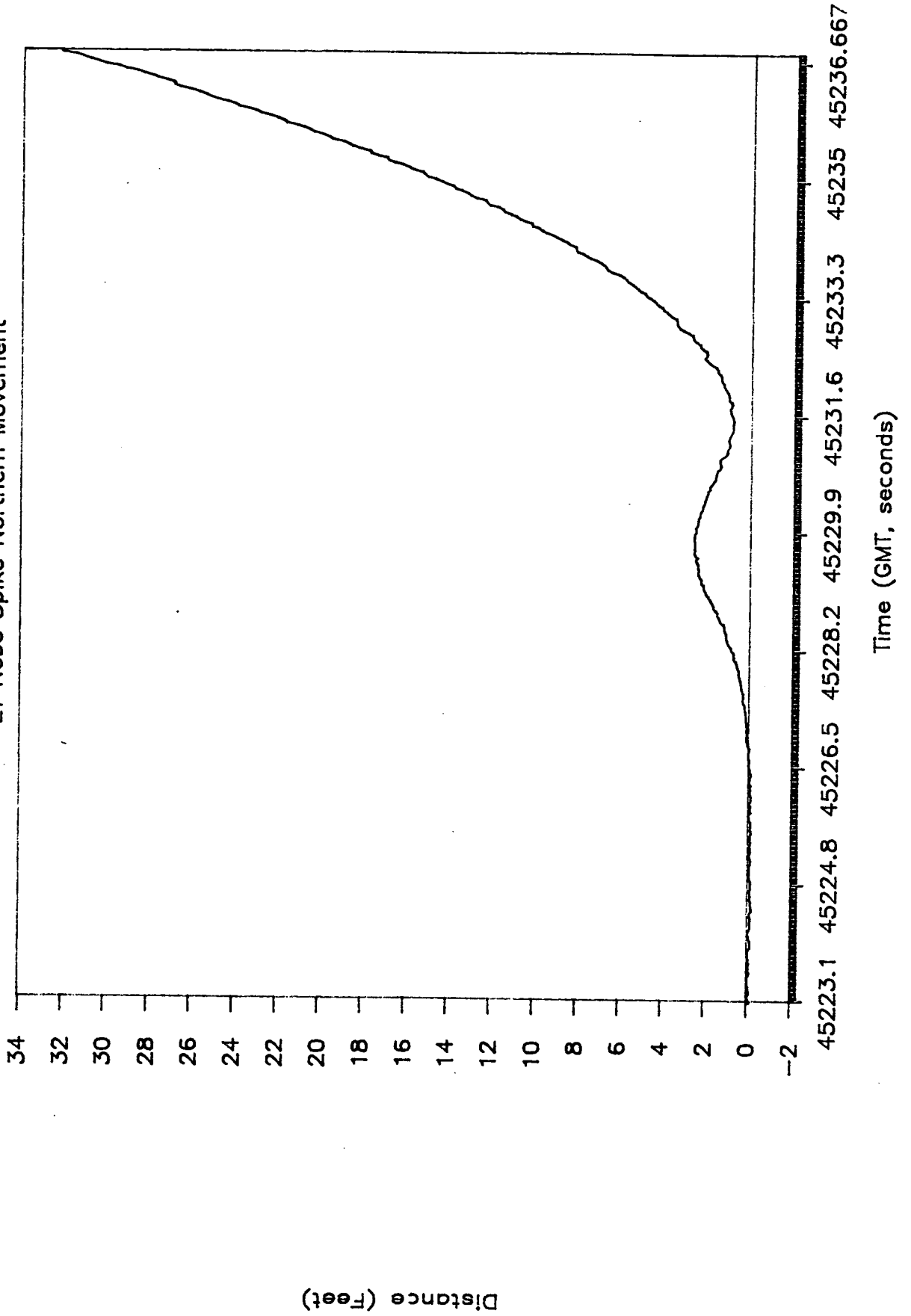

Distance (Feet)

Many film and video items recorded various amounts of flying debris on and around the pad after the vehicle cleared the tower. This debris is SRB throat plug material and shredded sound suppression water troughs - an expected occurrence.

Just after the roll program, 27 particles dropped out of the SRB plume near the RH aft skirt (E-59). The particles are believed to be pieces of aft skirt instafoam due to trajectory characteristics which indicate low density material. Four particles fell out of the SRB plumes in the approximate time frame T+70 through 77 seconds and were probably pieces of SRB aft skirt instafoam or chunks of SRB propellant/inhibitor (E-204, 206, 207, 210, 218, 220).

Numerous bright white flashes occurred in the SSME plume (E-54, 59). These flashes were not the typical orange streaks which can be explained by debris, such as RCS paper covers, entering the plume or fuel impurities (E-207, 212, 218, 220, 221). ET aft dome charring began prior to the roll maneuver. Plume recirculation at altitude was normal.

Due to vehicle attitude and sun angle, numerous reflections appeared on the orbiter windows/forward fuselage: just after the roll maneuver began, 27 seconds prior to SRB separation, and 76 seconds after SRB separation.

Orbiter performance, landing gear extension, wheel touchdown, and vehicle rollout after landing at Edwards AFB was nominal.

No PR's or IPR's were generated as a result of the film and video data review. However, the Post Launch Anomalies observed in the Film Review and IFA candidates were presented to the Mission Management Team, Shuttle managers, and vehicle systems engineers. These anomalies are listed in Section 11.2.

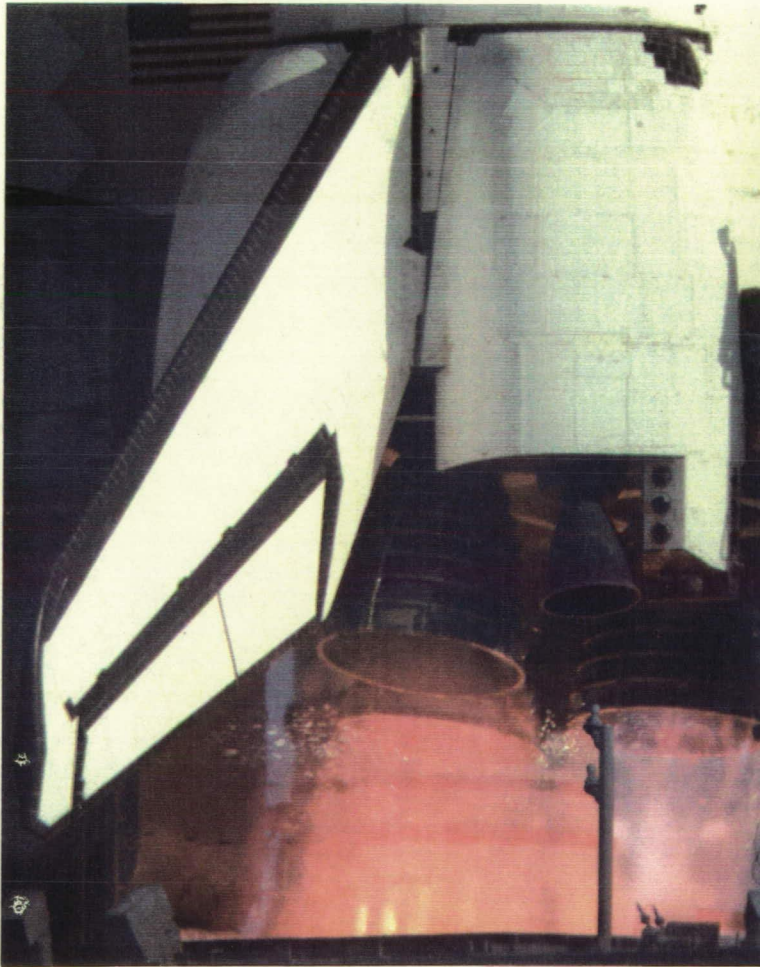

ORIGINAL PAGE  
COLOR PHOTOGRAPH

Before/after view of rudder speed brake as SSME ignition  
acoustics/vibration cause a 2-1/2" chip in a tile (E-76)

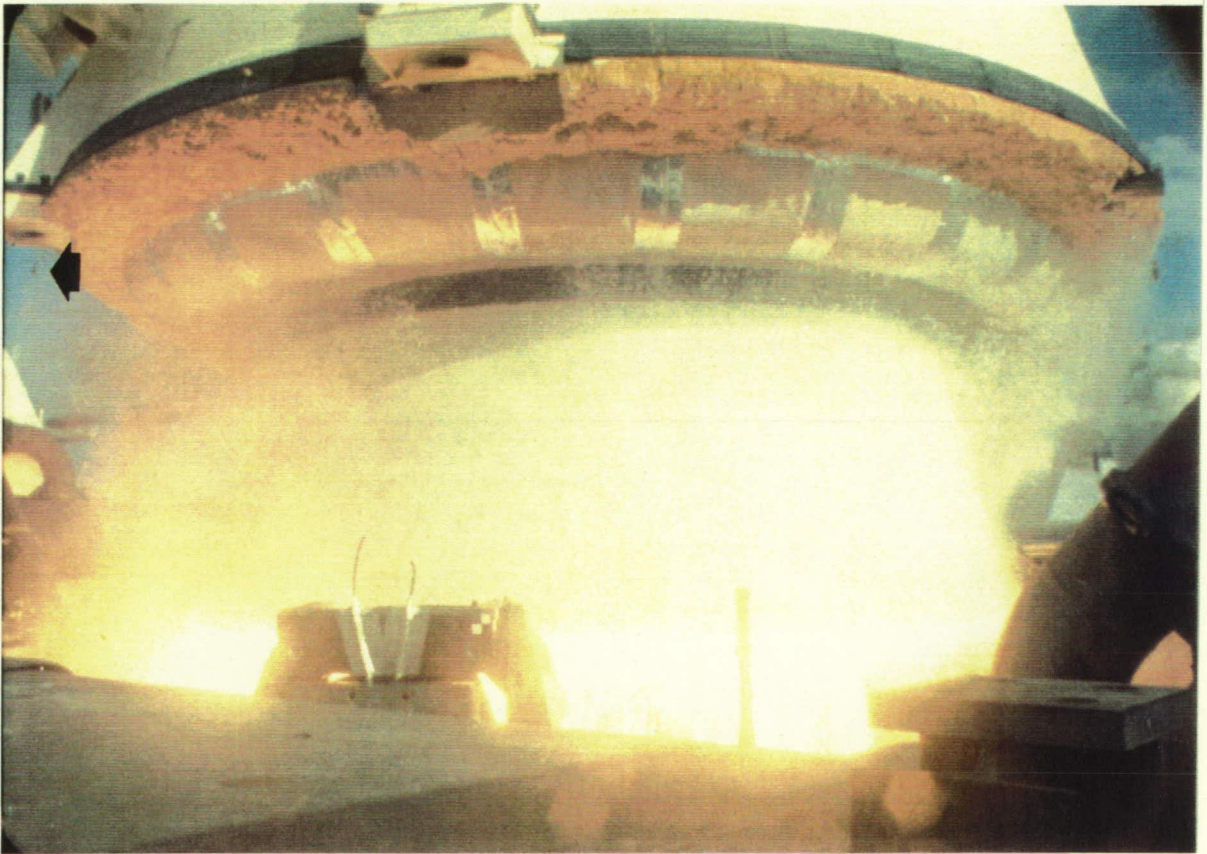

ORIGINAL PAGE  
COLOR PHOTOGRAPH

An ordnance debris fragment falls from the RH SRB HDP #1  
stud hole shortly after liftoff (E-8)

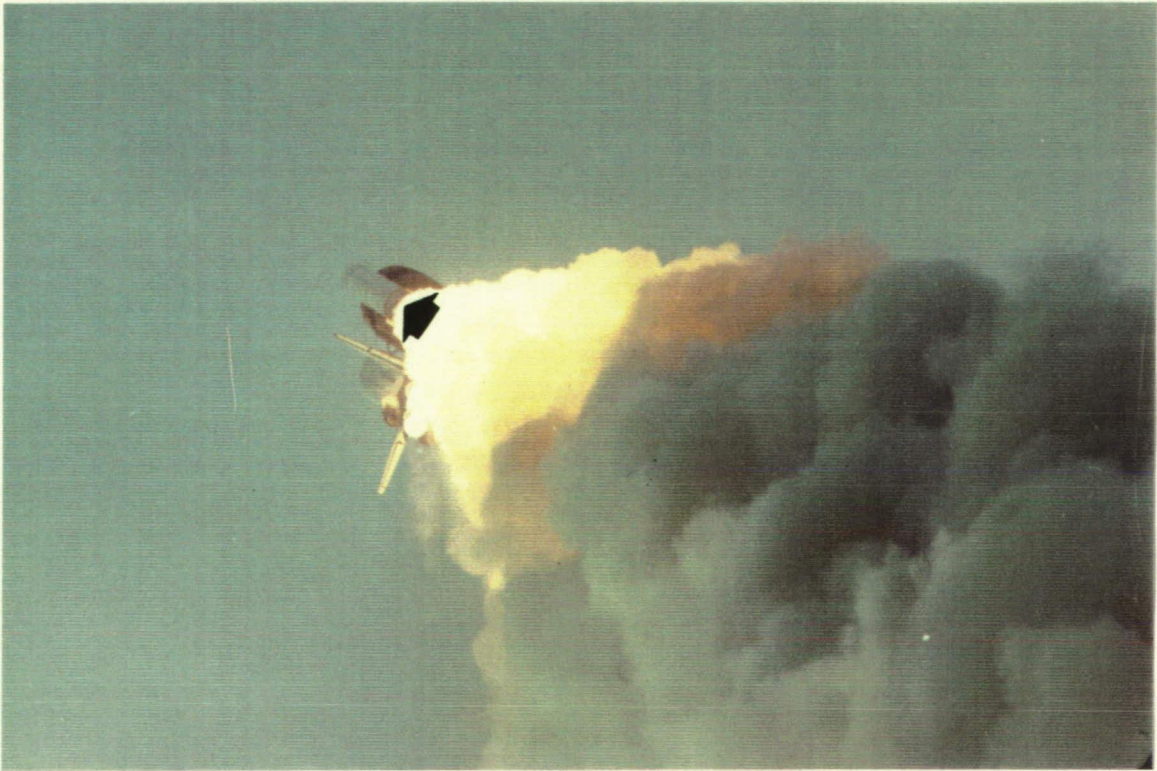

As many as 27 particles, most likely SRB aft skirt instafoam, fall from the vehicle just after the roll maneuver (E-59)

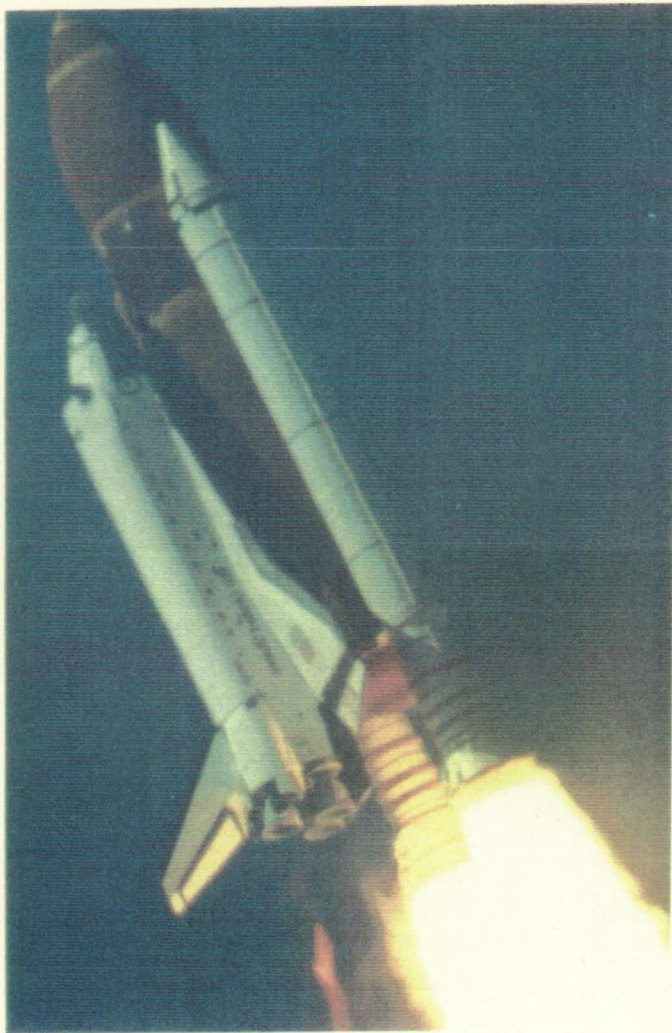

ORIGINAL PAGE IS  
OF POOR QUALITY

Orange flashes continue to occur in the SSME plumes during ascent (E-212) and may be caused by debris

## 7.1 LAUNCH FILM AND VIDEO DATA REVIEW

### FILM ITEMS

**EX1** Camera is located on MLP deck south of RH SRB  
400 FPS exhaust duct and looks north to view holddown  
16mm post #1 shoe for possible movement during period  
from SSME ignition to SRB ignition.

Focus : OK  
F. O. V.: OK  
Exposure: OK  
Note : EXCESSIVE CAMERA SHAKE

Comments: AT SSME IGNITION, SRB SKIRT LIFTS 1/2", PAUSES, LIFTS  
AGAIN, THEN PULLS AWAY FROM THE SHOE.

**EX2** Camera is located on the MLP deck west of RH SRB  
400 FPS flame duct and looks east to view SRB Heater  
16mm Umbilical during ignition and liftoff.

Focus : OK  
F. O. V.: OK  
Exposure: OK

Comments: T-0 UMBILICAL SEPARATES PRIOR TO UPSURGE OF EXHAUST.  
SEPARATION OF THE SRB T-0 UMBILICAL WAS NORMAL. T-0 CAUSES WATER  
IN THE SOUND SUPPRESSION WATER TROUGHS TO GEYSER UPWARD.

**EX3** Camera is located on the MLP deck east of LH SRB  
400 FPS flame duct and looks west to view SRB Heater  
16mm Umbilical during ignition and liftoff.

Focus : OK  
F. O. V.: OK  
Exposure: OK

Comments: SSME IGNITION CAUSES SMALL PIECES OF ET/ORB UMBILICAL  
ICE TO FALL AND BOUNCE ON MLP DECK PRIOR TO T-0. T-0 UMBILICAL  
SEPARATES AFTER UPSURGE OF EXHAUST. SEPARATION OF THE SRB T-0  
UMBILICAL WAS NOMINAL. T-0 CAUSES WATER IN THE SOUND SUPPRESSION  
WATER TROUGHS TO GEYSER UPWARD.



**EX4** Camera is located on MLP deck south of LH SRB  
400 FPS flame duct and looks north to view LH SRB Heater  
16mm Umbilical during ignition and liftoff.

Focus : OK  
F. O. V.: OK  
Exposure: OK

Comments: PIECES OF ET/ORB UMBILICAL ICE FALL AFTER SSME IGNITION. ICE IMPACTS SRB AFT SKIRT AND MLP DECK NO VEHICLE DAMAGE. SEPARATION OF SRB T-0 UMBILICAL IS OBSCURED. DCS OSCILLATES AT T-0. SRB HOLDDOWN POST SHOE ROCKS SLIGHTLY AFTER SEPARATION WITH SRB AFT SKIRT. AFTER 1 FOOT OF VEHICLE RISE, A PIECE OF SHIM PUTTY COMES LOOSE FROM INBOARD SIDEWALL AREA. FIVE PIECES OF SRB AFT SKIRT INSTAFOAM ARE PULLED LOOSE WITH VEHICLE RISE. FIRST PIECE ORIGINATES FROM HDP SHOE CORNER. ONE PIECE OF INSTAFOAM 1.5 INCHES LONG COMES LOOSE FROM SANDED AREA NEAR AFT SKIRT FOOT.

**E-1** Camera is located on the NE corner of the MLP deck  
400 FPS and views the lower ET, SRB's, and Orbiter.  
16mm

Focus : OK  
F. O. V.: OK  
Exposure: OK  
Note : EXCESSIVE CAMERA SHAKE

Comments: ICE PARTICLES FALL FROM THE ET/ORBITER UMBILICALS AT SSME START. WATER IN LH SRB STIFFENER RINGS VAPORIZES. SOUND SUPPRESSION WATER TROUGH CORD IS EJECTED FROM RH SRB EXHAUST HOLE.

**E-2** Camera is located on the SE corner of the MLP deck  
400 FPS and views Orbiter SSME and OMS engine nozzles.  
16mm

Focus : OK  
F. O. V.: OK  
Exposure: OK

Comments: WATER IN RH SRB STIFFENER RINGS VAPORIZES. RCS BUTCHER PAPER COVERS TEAR AND FALL FROM THE RH ARCS THRUSTERS. AT 47.655 SECONDS, A SMALL PIECE OF TILE FALLS FROM THE AFT TRAILING EDGE OF THE RH RUDDER SPEEDBRAKE.

E-3 Camera is located on the SW corner of the MLP deck  
400 FPS and views Orbiter SSME and OMS engine nozzles.  
16mm

Focus : OK  
F. O. V.: OK  
Exposure: OK  
Note : EXCESSIVE CAMERA SHAKE

Comments: FREE BURNING HYDROGEN IS BLOWN WESTWARD AT SSME IGNITION. WATER IN LH SRB STIFFENER RINGS VAPORIZES. NUMEROUS SMALL FACILITY DEBRIS PARTICLES PASS THROUGH THE FOV AS THE VEHICLE RISES. RCS BUTCHER PAPER COVERS TEAR AND FALL FROM THE LH ARCS THRUSTERS.

E-4 Camera is located on the NW corner of the MLP deck  
400 FPS and views lower ET, SRB's, and Orbiter.  
16mm

Focus : OK  
F. O. V.: OK  
Exposure: OK  
Note : EXCESSIVE CAMERA SHAKE

Comments: ICE PARTICLES FALL FROM LO2 ET/ORBITER UMBILICAL AT SSME START. THROAT PLUG MATERIAL IS EJECTED FROM THE RH SRB EXHAUST HOLE AT SRB IGNITION.

E-5 Camera is located on the east side of the MLP  
400 FPS deck and views the Orbiter RH wing, body flap,  
16mm and lower ET/SRB.

Focus : OK  
F. O. V.: OK  
Exposure: OK

Comments: ICE PARTICLES FALL FROM THE LH2 AND LO2 ET/ORBITER UMBILICALS. THE RH OUTBOARD ELEVON EXHIBITS TYPICAL MOTION AT T-0. FROST IS VISIBLE ON THE NOZZLE OF SSME #3.

E-6 Camera is located on the east side of the MLP deck  
200 FPS and views the RH lower Orbiter wing, body flap, ET  
16mm lower LOX feedline, and ET/Orbiter umbilical area.

Focus : OK  
F. O. V.: OK  
Exposure: OK

Comments: ICE FALLS FROM ET/ORB UMBILICALS DURING SSME IGNITION. RH ELEVON MOVES DURING IGNITION. ONE PIECE OF LH2 UMBILICAL PURGE BARRIER APPEARS TO TEAR LOOSE AND FALL AFTER T-0.

E-7 Camera is located on the MLP deck and views the  
400 FPS RH SRB northeast holddown post (HDP #4).  
16mm

Focus : OK  
F. O. V.: OK  
Exposure: OK

Comments: WATER LEAKS FROM SOUND SUPPRESSION PIPE ON LEFT SIDE OF FRAME. AT T-0, NUMEROUS PARTICLES ARE EJECTED UPWARD FROM SRB EXHAUST HOLE. PARTICLES INCLUDE SRB THROAT PLUG, WATER TROUGH MATERIAL AND PARACHUTE CORD. DARK SMOKE FROM BURNING FOAM OUTGAS PRODUCTS TRAVELS UP INBOARD EDGE OF HDP #4 AND DEFLECTS OFF SRB FOOT.

E-8 Camera is located on the MLP deck and views the  
400 FPS RH SRB southeast holddown post (HDP #2).  
16mm

Focus : OK  
F. O. V.: OK  
Exposure: OK  
Note : EXCESSIVE CAMERA SHAKE

Comments: A MOTH MOVES ACROSS FOV AT SSME IGNITION. SEVERAL PIECES OF SRB THROAT PLUG MATERIAL ARE EJECTED FROM SRB EXHAUST HOLE. HDP #2 ROCKS SLIGHTLY DURING VEHICLE LIFTOFF.

E-9 Camera is located on the MLP deck and views the  
400 FPS RH SRB southwest holddown post (HDP #1).  
16mm

Focus : OK  
F. O. V.: OK  
Exposure: UNDEREXPOSED  
Note : EXCESSIVE CAMERA SHAKE

Comments: ICE PARTICLES FROM THE LO2 T-0 UMBILICAL PASS THROUGH THE FOV. A 5" X 3/4" PIECE OF TAPE RISES UP FROM THE HDP #1 HAUNCH AREA AT SRB IGNITION. A 2" X 6" PIECE OF DEBRIS (PERHAPS

SAME PIECE OF TAPE) FALLS THROUGH THE FOV IN FRAME 4063. AFTER VEHICLE RISES APPROXIMATELY 3 FEET, A 1/2" X 3.5" PIECE OF FRANGIBLE NUT FALLS FROM THE HDP #1 STUD HOLE.

E-10                    Camera is located on the MLP deck and views the  
400 FPS                RH SRB northwest holddown post (HDP #3).  
16mm

Focus        :    OK  
F. O. V.:    OK  
Exposure:    OK

Comments:    WATER AND SMALL DECK DEBRIS APPEAR AT SSME IGNITION AND T-0. THE HDP DOGHOUSE BLAST COVER CLOSES NORMALLY..

E-11                    Camera is located on the MLP deck and views the  
400 FPS                LH SRB northeast holddown post (HDP #7).  
16mm

Focus        :    OK  
F. O. V.:    OK  
Exposure:    LIGHT INTRUDES INTO CAMERA BOX

Comments:    DECK DEBRIS IS STIRRED UP AT SSME IGNITION. A NORMAL AMOUNT OF SRB THROAT PLUG MATERIAL IS EJECTED UPWARD OUT OF THE SRB EXHAUST HOLE. A SMALL PIECE OF SRB AFT SKIRT INSTAFOAM AROUND HDP BREAKS LOOSE AT T-0.

E-12                    Camera is located on the MLP deck and views the  
400 FPS                LH SRB southeast holddown post (HDP #5).  
16mm

Focus        :    OK  
F. O. V.:    OK  
Exposure:    OK  
Note        :    EXCESSIVE CAMERA SHAKE

Comments:    SMALL ICE PARTICLES FALL FROM THE ET/ORBITER LH2 UMBILICAL TO THE MLP DECK AT SSME START. THROAT PLUG MATERIAL IS EJECTED FROM THE LH EXHAUST HOLE AT SRB IGNITION.

E-13 Camera is located on the MLP deck and views the  
400 FPS LH SRB southwest holddown post (HDP #6).  
16mm

Focus : OK  
F. O. V.: OK  
Exposure: OK

Comments: DECK DEBRIS IS KICKED-UP AT SSME IGNITION. ICE/FROST  
FALLS FROM ET/ORB LH2 UMBILICAL. SRB THROAT PLUG MATERIAL IS  
EJECT FROM SRB EXHAUST HOLE AFTER T-0.

E-14 Camera is located on the MLP deck and views the  
400 FPS LH SRB northwest holddown post (HDP #8).  
16mm

Focus : OK  
F. O. V.: OK  
Exposure: OK

Comments: SRB THROAT PLUG MATERIAL IS EJECTED FROM SRB EXHAUST  
HOLE AFTER T-0. SRB HDP DOGHOUSE BLAST COVERS CLOSE NORMALLY.

E-15 Camera is located on the MLP deck and views the RH  
400 FPS SRB skirt, sound suppression water troughs, and RH  
16mm lower Orbiter body flap.

Focus : OK  
F. O. V.: OK  
Exposure: OK

Comments: ICE PARTICLES FALL FROM THE ET/OBITER UMBILICALS AT  
SSME START. TYPICAL QUANTITIES OF WATER TROUGH AND THROAT PLUG  
MATERIAL ARE EJECTED FROM THE RH EXHAUST HOLE AT SRB IGNITION.  
HOLDDOWN POST DOGHOUSE BLAST COVERS APPEAR TO CLOSE NORMALLY.  
GRAY SMOKE FROM AFT SKIRT INSTAFOAM OUTGAS PRODUCTS APPEAR AS THE  
VEHICLE RISES.

E-16 Camera is located on the MLP deck and views the LH  
400 FPS SRB skirt, sound suppression water troughs, and LH  
16mm lower Orbiter body flap.

Focus : OK  
F. O. V.: OK  
Exposure: OK

Comments: ICE PARTICLES FALL FROM THE ET/ORBITER UMBILICALS AT SSME START. TYPICAL QUANTITIES OF WATER TROUGH AND THROAT PLUG MATERIAL ARE EJECTED FROM THE LH EXHAUST HOLE AT SRB IGNITION. A DEBRIS PARTICLE RISES UP FROM BEHIND HOLDDOWN POST #7 DEBRIS CONTAINMENT ASSEMBLY. THE HOLDDOWN POST DOGHOUSE BLAST COVERS APPEAR TO CLOSE NORMALLY.

E-17 Camera is located on the MLP deck and views the  
400 FPS -Z side of the LO2 T-0 Umbilical and TSM.  
16mm

Focus : OK  
F. O. V.: OK  
Exposure: OK  
Note : EXCESSIVE CAMERA SHAKE

Comments: BODY FLAP AND RH ELEVONS EXHIBIT TYPICAL MOVEMENT AT SSME START. ICE PARTICLES FALL FROM THE LO2 T-0 UMBILICAL. VERY LITTLE RESIDUAL GO2 VAPOR IS PRESENT UPON RETRACTION OF THE UMBILICAL.

E-18 Camera is located on the MLP deck and views the  
400 FPS -Z side of the LH2 T-0 umbilical and TSM.  
16mm

Focus : OK  
F. O. V.: OK  
Exposure: OK

Comments: FREE BURNING HYDROGEN BLOWS WEST ACROSS FOV. ICE PARTICLES FALL FROM THE LH2 ET/ORBITER AND TSM T-0 UMBILICAL AT SSME IGNITION. A PART TAG FALLS FROM THE LH2 T-0 UMBILICAL FLUID LINES JUST AFTER SEPARATION. AT T-0 UMBILICAL SEPARATION A PIECE OF BLACK DEBRIS FALLS FROM THE SEPARATION PLANE AREA. NO ORBITER BASE HEAT SHIELD TILE DAMAGE IS VISIBLE.

E-19 Camera is located on the SE side of the MLP deck  
400 FPS and views the SSME/OMS nozzles and Orbiter aft  
16mm heat shield area.

Focus : OK  
F. O. V.: OK  
Exposure: OK

Comments: ICE PARTICLES FALL FROM THE ET/ORB AND TSM T-0 UMBILICALS AT SSME START. VERY LITTLE RESIDUAL GOX VAPOR IS PRESENT DURING RETRACTION OF THE LO2 T-0 UMBILICAL. LH2 TSM DOOR BOUNCES UPON CLOSING.

**E-20** Camera is located on the SW side of the MLP deck  
400 FPS and views the SSME/OMS nozzles and Orbiter aft  
16mm heat shield area.

Focus : OK  
F. O. V.: OK  
Exposure: OK

Comments: ICE PARTICLES FALL FROM THE ET\ORBITER AND T-0 UMBILICALS AT SSME START. RESIDUAL LH2 VAPORIZES UPON RETRACTION OF THE LH2 T-0 UMBILICAL. A PART TAG (SEE ITEM E-18) FALLS FROM THE LH2 T-0 UMBILICAL DURING RETRACTION. LO2 TSM DOOR BOUNCES ONCE UPON CLOSING.

**E-21** Camera is located inside the LO2 TSM and views  
200 FPS the disconnection of the T-0 umbilical.  
16mm

Focus : OK  
F. O. V.: OK  
Exposure: OK

Comments: VEHICLE TWANG IS NORMAL. T-0 UMBILICAL SEPARATION IS NOMINAL. VERY LITTLE RESIDUAL VAPORS ARE VISIBLE IN FLIGHT QD. TSM DOOR BOUNCES APPROXIMATELY 1" DURING CLOSURE.

**E-22** Camera is located inside the LH2 TSM and views  
200 FPS the disconnection of the T-0 umbilical.  
16mm

Focus : OK  
F. O. V.: OK  
Exposure: OK

Comments: PURGE BARRIER IS INTACT PRIOR TO SSME IGNITION BUT COMES LOOSE SOON AFTER. T-0 UMBILICAL SEPARATION IN NOMINAL. NORMAL AMOUNT OF RESIDUAL VAPORS IS VISIBLE IN FLIGHT QD. TSM DOOR BOUNCES SLIGHTLY BEFORE CLOSURE.

E-23                    Camera is located on the MLP deck and views the  
400 FPS                RH OMS engine nozzle.  
16mm

Focus     :    OK  
F. O. V.:    OK  
Exposure:    OK

Comments:    RH OMS NOZZLE FLEXES SLIGHTLY DURING SSME IGNITION.  
RCS PAPER COVERS TEAR AND PIECES ARE PULLED INTO THE PLUME BY  
ASPIRATION. SEVERAL SMALL PIECES OF TILE SURFACE COATING MATERIAL  
FALL FROM THE AFT HEAT SHIELD BETWEEN SSME #1 AND #3 AFTER SSME  
IGNITION. ICE FALLS FROM LO2 T-0 UMBILICAL AT SSME IGNITION AND  
T-0. LO2 UMBILICAL RETRACTION IS NOMINAL. TSM DOOR CLOSES  
NORMALLY.

E-24                    Camera is located on the MLP deck and views the  
400 FPS                LH OMS engine nozzle.  
16mm

Focus     :    OK  
F. O. V.:    OK  
Exposure:    OK

Comments:    LH OMS NOZZLE FLEXES SLIGHTLY DURING SSME IGNITION.  
RCS PAPER COVERS TEAR AND PIECES ARE PULLED INTO THE PLUME BY  
ASPIRATION. FREE HYDROGEN BURNS AT SSME IGNITION. ICE FALLS FROM  
LH2 T-0 UMBILICAL AT SSME IGNITION. RESIDUAL CRYOGENICS VAPORIZE  
IN THE FLIGHT QD. A Q-FELT PLUG FALLS FROM AFT EDGE OF LH STINGER  
(FRAME #3180). TILE DINGS APPEAR ON LH STINGER AFTER SSME IGNI-  
TION. LH2 TSM DOOR REBOUNDS BUT CLOSES NORMALLY. ICE FROM LH2  
ET/ORB UMBILICAL FALLS AS VEHICLE LEAVES FOV.

E-25                    Camera is located on the east side of the MLP and  
400 FPS                views between Orbiter and ET/SRB during liftoff.  
16mm

Focus     :    OK  
F. O. V.:    OK  
Exposure:    UNDEREXPOSED

Comments:    ICE PARTICLES FALL FROM THE ET/ORBITER UMBILICALS.  
TYPICAL ELEVON MOTION IS APPARENT UPON SSME IGNITION AND LIFTOFF.  
NO VEHICLE ANOMALIES.



**E-26** Camera is located on the west side of the MLP and  
400 FPS views between Orbiter and ET/SRB during liftoff.  
16mm

Focus : OK  
F. O. V.: OK  
Exposure: OVEREXPOSED BY SUN

Comments: ICE PARTICLES FALL FROM THE ET/ORBITER UMBILICALS. GH2 VENT LINE RETRACTION APPEARS NORMAL. TYPICAL QUANTITIES OF THROAT PLUG MATERIAL ARE EJECTED FROM THE LH EXHAUST HOLE AT SRB IGNITION. WATER IN THE LH SRB STIFFENER RING VAPORIZES. A 2" DIAMETER, FOAM-COLORED PARTICLE IS FIRST NOTED FALLING THROUGH THE FOV NEAR THE CENTER SPLICE ON THE LH SRB SYSTEMS TUNNEL, FORWARD OF THE FORWARD-MOST STIFFENER RING.

**E-27** Camera is located on the MLP deck and views RH SRB  
400 FPS northwest holddown post (HDP #3) blast cover.  
16mm

Focus : SOFT  
F. O. V.: OK  
Exposure: OK

Comments: DARK SMOKE FROM INSTAFOAM OUTGAS PRODUCTS IS VISIBLE IN REGION OF HDP #4 (SEE ITEM E-7). SRB THROAT PLUG MATERIAL IS THROWN OUT OF SRB EXHAUST HOLE AT T-0. THE SRB HDP DOGHOUSE BLAST COVERS CLOSE NORMALLY.

**E-28** Camera is located on the MLP deck and views LH SRB  
400 FPS northeast holddown post (HDP #7) blast cover.  
16mm

Focus : OK  
F. O. V.: OK  
Exposure: OK

Comments: SRB THROAT PLUG MATERIAL IS EJECTED FROM THE SRB EXHAUST HOLE AT T-0. A DARK PARTICLE APPEARS FROM BEHIND DCA ASSEMBLY AT T-0. THE SRB HDP DOGHOUSE BLAST COVERS CLOSE NORMALLY.

**E-30** Camera is located on the FSS 195 foot level and  
400 FPS views LH SRB and sound suppression water troughs.  
16mm

Focus : OK  
F. O. V.: OK  
Exposure: OK

Comments: WATER DELUGE FROM HAUNCH PARTIALLY OBSCURES LEFT SIDE  
OF VIEW. ICE PARTICLES FALL FROM THE LH2 ET/ORB UMBILICAL.

**E-31** Camera is located on the FSS 95 foot level and  
100 FPS views the LH Orbiter wing, body flap, and  
16mm ET/Orbiter LH2 umbilical area.

Focus : OK  
F. O. V.: OK  
Exposure: UNDEREXPOSED

Comments: ICE PARTICLES FALL FROM THE ET/ORB UMBILICAL DURING  
SSME IGNITION AND T-0. WATER DELUGE OBSCURES VIEW.

**E-33** Camera is located on the FSS 235 foot level and  
400 FPS views the ET GH2 vent line and GUCP.  
16mm

Focus : OK  
F. O. V.: OK  
Exposure: OK

Comments: ICE PARTICLES FALL FROM GUCP AFTER SSME IGNITION AND  
T-0. ET TWANG IS NORMAL. GUCP DISCONNECT/RETRACTION IS NOMINAL.  
RESIDUAL VAPORS TRAIL FROM FLIGHT QD AS VEHICLE PASSES.

**E-34** Camera is located on FSS at 255 foot level and  
400 FPS views upper Orbiter tile surfaces.  
16mm

Focus : OK  
F. O. V.: OK  
Exposure: OK

Comments: GH2 VENT LINE RETRACTS PROPERLY. ICE PARTICLES FALL  
FROM THE ET/ORBITER UMBILICALS. CONDENSATE VAPORIZES ON THE ET  
AFT DOME. RESIDUAL LH2 VAPORIZES UPON RETRACTION OF THE LH2 T-0  
UMBILICAL AND VAPOR TRAILS FROM THE ORBITER QD AS THE VEHICLE

RISES. FIVE ICE PARTICLES, PROBABLY FROM THE LO2 FEEDLINE UPPER BELLOWS OR SUPPORT BRACKET, ARE FIRST VISIBLE FALLING PAST THE LH BIPOD CLOSEOUT. NO VEHICLE CONTACT THRU LOV. FACILITY DEBRIS PASSES THROUGH THE FOV AFTER THE VEHICLE CLEARS THE TOWER.

**E-35** Camera is located on the FSS 255 foot level and  
400 FPS views the mid-Orbiter/ET/SRB area.  
16mm

Focus : OK  
F. O. V.: OK  
Exposure: OK

Comments: GH2 VENT LINE RETRACTS PROPERLY. ICE PARTICLES FALL FROM THE ET/ORBITER UMBILICALS AS VEHICLE RISES THROUGH FOV. RESIDUAL LH2 VAPORIZES UPON RETRACTION OF THE LH2 T-0 UMBILICAL AND VAPOR TRAILS FROM THE ORBITER QD AS THE VEHICLE RISES. THREE ICE PARTICLES FALL FROM TOP FOV WITH NO VEHICLE CONTACT. ONE OF THESE PARTICLE IS VISIBLE IN ITEM E-36 IMPACTING LH WING AND BREAKING INTO 2 PIECES WITH NO VEHICLE DAMAGE. FACILITY DEBRIS PASSES THROUGH THE FOV AFTER THE VEHICLE CLEARS THE TOWER.

**E-36** Camera is located on the FSS 255 foot level and  
400 FPS views lower Orbiter, ET, SRB's, and water trough.  
16mm

Focus : OK  
F. O. V.: OK  
Exposure: OK

Comments: RUSTY DELUGE WATER IS SPRAYED FROM THE GH2 VENT LINE HAUNCH FIREX NOZZLES. ICE PARTICLES FALL FROM THE ET/ORBITER UMBILICALS FROM SSME IGNITION THROUGH LOV. SHORTLY AFTER LIFTOFF, AN ICE PARTICLE FALLING FROM ABOVE, CONTACTS THE LH WING LOWER SURFACE AND BREAKS INTO TWO PIECES. NO TILE DAMAGE IS VISIBLE. FACILITY DEBRIS PASSES THROUGH THE FOV AFTER THE VEHICLE CLEARS THE TOWER.

**E-40** Camera is located on the FSS 275 foot level and  
400 FPS views the ET ogive, SRB nosecone, and Orbiter  
16mm tiled surfaces.

Focus : OK  
F. O. V.: OK  
Exposure: OVEREXPOSED BY THE SUN

Comments: LIGHT FROST IS PRESENT ON THE -Y ET LO2 TANK LOUVER. ICE PARTICLES FALL FROM THE ET/ORBITER UMBILICALS. RESIDUAL LH2 VAPORIZES UPON RETRACTION OF THE T-0 UMBILICAL AND VAPOR TRAILS FROM THE ORBITER QD AS THE VEHICLE RISES. THREE LARGE PIECES OF RCS BUTCHER PAPER COVER FALL FROM THE ARCS THRUSTERS AS VEHICLE CLEARS THE FOV.

E-41 Camera is located on the FSS 255 foot level and  
400 FPS views the GH2 vent line during rotation. Also  
16mm shows clearance between structure and SRB aft  
skirt.

Focus : OK  
F. O. V.: OK  
Exposure: OK

Comments: GH2 VENT LINE RELEASE, RETRACT, AND LATCHBACK IS NOMINAL. CONDENSATE VAPORIZES ON ET AFT DOME AND SRB STIFFENER RINGS. ORBITER LH WING CLEARS HAUNCH WITH NO VEHICLE ANOMALIES. FACILITY DEBRIS PARTICLES, INCLUDING ONE LARGE OBJECT (FRAME #6276), PASS THROUGH FOV AFTER VEHICLE CLEARS THE TOWER.

E-42 Camera is located on the FSS 185 foot level and  
400 FPS views the GH2 vent line drop, deceleration, and  
16mm latchback.

Focus : OK  
F. O. V.: OK  
Exposure: OK

Comments: GH2 VENT LINE RELEASE, RETRACT, AND LATCHBACK IS NOMINAL. EXCESSIVE SLACK IN STATIC RETRACT LANYARD CREATES LOOP OF CABLE THAT CONTACTS UNDERSIDE OF HAUNCH, REVERSES DIRECTION OF TRAVEL, COMES AROUND PULLEY AND CONTACTS THE GUCP. SMALL FACILITY DEBRIS PASSES THROUGH FOV AFTER VEHICLE CLEARS THE TOWER.

E-44 Camera is located on the FSS 155 foot level and  
400 FPS views the LH OMS Pod leading edge tiles during  
16mm ignition and liftoff.

Focus : OK  
F. O. V.: OK  
Exposure: OK  
Note : EXCESSIVE CAMERA SHAKE

Comments: RESIDUAL LH2 VAPORIZES UPON RETRACTION OF THE T-0 UMBILICAL AND VAPOR TRAILS FROM THE ORBITER QD. SMALL FROST PARTICLE PASSES THRU FOV (FRAME 4392) IN FRONT OF TSM. THIS MAY BE THE ICE PARTICLE FROM THE LO2 UPPER FEEDLINE BELLOWS OR SUPPORT BRACKET.

E-48 Camera is located on the FSS 215 foot level (ET  
400 FPS Intertank access arm structure) and views the GH2  
16mm vent line during GUCP disconnection, rotation, and  
latchback

Focus : OK  
F. O. V.: OK  
Exposure: OK

Comments: GUCP DISCONNECT/RETRACTION IS NOMINAL. SMALL PIECES OF ICE FALL AT DISCONNECT. LIGHT COATING OF FROST IS PRESENT AROUND EDGES OF UMBILICAL CARRIER PLATE.

E-50 Camera is located at camera site 1 at NE pad  
400 FPS perimeter and views entire GH2 vent line and  
16mm GUCP during rotation and latchback.

Focus : OK  
F. O. V.: OK  
Exposure: OK

Comments: GUCP ICE FALLS PAST VEHICLE AND IS VISIBLE AGAINST BLACK EB FITTING COVER. GH2 VENT LINE RETRACTION/LATCHBACK APPEARS NOMINAL. CONDENSATE VAPORIZES ON ET AFT DOME AND SRB STIFFENER RINGS.

E-52 Camera is located at camera site 2 on the east pad  
96 FPS perimeter. Remote tracking of lower one-third of  
35mm launch vehicle from ignition to 1200 feet.

Focus : OK  
F. O. V.: OK  
Exposure: OK

Comments: ICE PARTICLES FALL FROM ET/ORB UMBILICALS AT SSME IGNITION AND T-0. GH2 VENT LINE RETRACTION APPEARS NOMINAL. CONDENSATE VAPORIZES ON THE ET AFT DOME AND SRB STIFFENER RINGS. NUMEROUS PARTICLES OF AFT RCS PAPER COVERS TEAR LOOSE AFTER

VEHICLE CLEARS TOWER. CHARRING OCCURS ON AFT DOME PRIOR TO ROLL PROGRAM. FORWARD RCS PAPER COVER TEARS LOOSE AT START OF ROLL PROGRAM. BRIGHT WHITE ENGINE FLASHES OCCUR IN SSME #3 PLUME.

**E-53** Camera is located at camera site 2 on the east pad  
96 FPS perimeter. Remote tracking of middle one-third of  
35mm launch vehicle from ignition to 1200 feet.

Focus : OK  
F. O. V.: OK  
Exposure: OK

Comments: SEE FILM ITEM E-52

**E-54** Camera is located at camera site 2 on the east pad  
96 FPS perimeter. Remote tracking of upper one-third of  
35mm launch vehicle from ignition to 1200 feet.

Focus : OK  
F. O. V.: OK  
Exposure: OK

Comments: GH2 VENT LINE RETRACT APPEARS NOMINAL. CONDENSATE VAPORIZES ON ET AFT DOME AND SRB STIFFENER RINGS. BRIGHT WHITE FLASHES OCCUR IN THE PLUME OF ENGINE #3 AFTER ROLL PROGRAM. RCS PAPER COVERS COMES LOOSE FROM LEFT FORWARD DURING ROLL PROGRAM (FRAME 125-05).

**E-57** Camera is located at camera site 6 on the NW pad  
96 FPS perimeter. Remote tracking of lower one-third of  
35mm launch vehicle from ignition to 1200 feet.

Focus : OK  
F. O. V.: OK  
Exposure: OK

Comments: SEE FILM ITEM E-59.

**E-58** Camera is located at camera site 6 on the NW pad  
96 FPS perimeter. Remote tracking of center one-third of  
35mm launch vehicle from ignition to 1200 feet.

Focus : OK  
F. O. V.: OK  
Exposure: OK

Comments: SEE FILM ITEM E-59.

**E-59** Camera is located at camera site 6 on the NW pad  
96 FPS perimeter. Remote tracking of upper one-third of  
35mm launch vehicle from ignition to 1200 feet.

Focus : OK  
F. O. V.: OK  
Exposure: OK

Comments: CONDENSATE VAPORIZES ON SRB AFT STIFFENER RINGS AND ET AFT DOME. THE ET AFT DOME EXHIBITS CHARRING PRIOR TO ROLL PROGRAM. BRIGHT WHITE FLASHES OCCUR IN SSME PLUME AFTER ROLL PROGRAM, 27 PARTICLES (FRAME 2070-2340), WHICH MAY BE PIECES OF INSTAFOAM FROM THE RH AFT SKIRT, FALL FROM THE VEHICLE JUST AFTER THE ROLL MANEUVER IS COMPLETE.

**E-60** Camera is located on north pad perimeter at camera  
96 FPS site 1 and views the entire launch vehicle, FSS,  
35mm and MLP zero level.

Focus : OK  
F. O. V.: OK  
Exposure: OK

Comments: ICE PARTICLES FALL FROM THE ET/ORB UMBILICALS AFTER SSME IGNITION. GH2 VENT ARM RETRACTS AND LATCHES NORMALLY. CONDENSATE VAPORIZES ON SRB STIFFENER RINGS AND ET AFT DOME.

**E-61** Camera is located at camera site 2 on the east pad  
100 FPS perimeter and views the launch vehicle, FSS, and  
35mm MLP.

Focus : OK  
F. O. V.: OK  
Exposure: OK

Comments: ICE PARTICLES FALL FROM ET/ORB THE UMBILICALS AT SSME IGNITION. GH2 VENT LINE RETRACTS NORMALLY. ICE/FROST FALLS FROM MLP CRYO LINES. CONDENSATE VAPORIZES ON THE ET AFT DOME AND SRB STIFFENER RINGS.

E-62 Camera is located on the SE pad perimeter at  
96 FPS camera site 3 and views entire vehicle, FSS, and  
35mm MLP.

Focus : OK  
F. O. V.: OK  
Exposure: OK

Comments: CONDENSATE VAPORIZES ON THE ET AFT DOME AND SRB STIFF-  
ENER RINGS. THREE LARGE PIECES OF UMBILICAL ICE FALL PAST THE  
BODY FLAP AS VEHICLE PASSES THE GH2 VENT LINE HAUNCH. RCS BUTCHER  
PAPER COVERS FALL FROM THE LEFT AFT RCS STINGER AS VEHICLE LEAVES  
FRAME.

E-63 Camera is located on SW pad perimeter at camera  
96 FPS site 4 and views entire launch vehicle, FSS, and  
35mm MLP.

Focus : OK  
F. O. V.: OK  
Exposure: OK

Comments: A WHITE BIRD APPEARS FROM BEHIND RSS AND HEADS EAST.  
RESIDUAL LH2 AND LO2 VAPORIZES UPON RETRACTION OF THE T-0 UMBILI-  
CALS. CONDENSATE VAPORIZES ON ET AFT DOME AND SRB STIFFENER  
RINGS. EMERGENCY EGRESS SLIDE WIRE BASKETS REMAIN SECURED TO FSS  
AFTER T-0. FACILITY DEBRIS CROSSES FOV WELL AFTER VEHICLE CLEARS  
TOWER.

E-64 Camera is located on NW pad perimeter at camera  
96 FPS site 6 and views entire launch vehicle, FSS, and  
35mm MLP.

Focus : OK  
F. O. V.: OK  
Exposure: OK

Comments: A BIRD CROSSES FOV BUT IS NOT NEAR VEHICLE. CONDENSATE  
VAPORIZES ON ET AFT DOME AND SRB STIFFENER RINGS. THREE PIECES OF  
UMBILICAL ICE FALL IN CENTER OF VIEW.



**E-65** Camera is located on east pad perimeter at camera  
100 FPS site 2 and views ET LO2 feedline, ET intertank,  
16mm and RH SRB as vehicle passes through the frame.

Focus : OK  
F. O. V.: OK  
Exposure: OK

Comments: ET TWANG NORMAL. ICE PARTICLES FALL FROM ET/ORBITER  
UMBILICALS DURING EARLY ASCENT. NO TILE IMPACTS DUE TO ICE. ICE  
REMAINS IN LO2 FEEDLINE BELLOWS THRU LOV.

**E-76** Camera is located on SE pad perimeter at camera  
96 FPS site 3 and views SSME engines #1 and #3 and the RH  
35mm OMS engine nozzle.

Focus : OK  
F. O. V.: OK  
Exposure: OK

Comments: TILE CHIP FROM RH SIDE OF RUDDER SPEED BRAKE FALLS OFF  
DURING SSME IGNITION. ICE PARTICLES FROM LOX T-0 UMBILICAL FALL  
INTO EXHAUST HOLE. ICE PARTICLES FALL FROM ET/ORBITER UMBILICALS  
DURING SSME IGNITION AND EARLY ASCENT. AN INSTAFOAM PARTICLE  
FALLS FROM LH SRB AFT SKIRT (FRAME 72-08).

**E-77** Camera is located on SW pad perimeter at camera  
96 FPS site 4 and views SSME engines #1 and #2 and the LH  
35mm OMS engine nozzle.

Focus : OK  
F. O. V.: OK  
Exposure: OK

Comments: ICE PARTICLES FALL FROM ENGINE LO2 DRAIN LINE AT SSME  
IGNITION. RCS PAPER COVERS TEAR AND ARE PULLED INTO THE ENGINE  
PLUME BY ASPIRATION. ICE PARTICLES FALL FROM THE ET/ORBITER  
UMBILICALS DURING SSME IGNITION AND LIFTOFF. LH2 T-0 UMBILICAL  
DISCONNECT AND RETRACTION NOMINAL. RESIDUAL LH2 VAPORIZES UPON  
RETRACTION.

**E-78** Camera is located on SE pad perimeter at camera  
400 FPS site 3 and views RH OMS Pod leading edge.  
16mm

Focus : OK  
F. O. V.: OK  
Exposure: OK

Comments: ICE PARTICLES FALL FROM THE ET/ORBITER UMBILICALS  
SHORTLY AFTER LIFTOFF. TILE CHIP IS MISSING FROM  
RUDDER/SPEEDBRAKE TRAILING EDGE (SEE E-76).

**E-79** Camera is located on east pad perimeter at  
100 FPS camera site 2 and views the ET nosecone, louver,  
16mm and ogive.

Focus : OK  
F. O. V.: OK  
Exposure: OK

Comments: ICE PARTICLES FALL FROM ET/ORBITER UMBILICALS SHORTLY  
AFTER LIFTOFF.

**E-201** UCS-9 IFLOT tracking of launch vehicle from  
30 FPS ignition and early flight through LOV.  
70mm

Focus : OK  
F. O. V.: OK  
Exposure: OK

Comments: CONDENSATE VAPORIZES ON ET AFT DOME AND SRB STIFFENER  
RINGS SHORTLY AFTER LIFTOFF. ET AFT DOME EXHIBITS CHARRING PRIOR  
TO ROLL PROGRAM. AFT RCS PAPER COVERS TEAR LOOSE AND ENTER PLUME.  
BRIGHT WHITE ENGINE FLASHES OCCUR IN THE SSME PLUME SHORTLY AFTER  
ROLL. TRACKING LOST SHORTLY AFTER ROLL.

**E-202** UCS-15 IFLOT tracking of launch vehicle from  
30 FPS ignition and early flight through LOV.  
70mm

Focus : OK  
F. O. V.: OK  
Exposure: OK

Comments: SEE FILM ITEM E-201.

**E-203** UCS-6 IFLOT tracking of launch vehicle from  
30 FPS ignition and early flight through LOV.  
70mm

Focus : OK  
F. O. V.: OK  
Exposure: OK

Comments: SEE FILM ITEM E-201. BRIGHT SPOTS ON RH INBOARD ELEVON TRAILING EDGE INBOARD CORNER AND IN GAP BETWEEN LH WING ELEVONS ARE REFLECTIONS.

**E-204** PAFB IGOR tracking of launch vehicle from  
48 FPS acquisition to SRB separation. Tracks ET/ORB  
35mm after SRB separation to LOV.

Focus : OK  
F. O. V.: OK  
Exposure: OK

Comments: PLUME RECIRCULATION IS NORMAL. FLASHES OCCUR IN SSME PLUME AT FRAME 96 FT/06. SRB SEPARATION IS NOMINAL. SLAG PARTICLES FALL FROM SRB NOZZLES AFTER SEPARATION.

**E-205** Shiloh IFLOT tracking of launch vehicle from  
48 FPS acquisition to SRB separation. Tracks ET/ORB  
35mm after SRB separation to LOV.

Focus : OK  
F. O. V.: OK  
Exposure: OK

Comments: EXHAUST PLUME OBSCURES VIEW OF VEHICLE AFT. SRB SEPARATION IS NOMINAL. VIEW BECOMES OBSCURED BY ATMOSPHERIC HAZE.

**E-206** Melbourne Beach ROTI tracking of launch vehicle  
48 FPS from acquisition to SRB separation. Tracks ET/ORB  
35mm after SRB separation to LOV.

Focus : OK  
F. O. V.: OK  
Exposure: OK

Comments: DETAILS OBSCURED BY ATMOSPHERIC HAZE. ET AFT DOME EXHIBITS TYPICAL CHARRING. PLUME RECIRCULATION IS NORMAL. SLAG PARTICLES FALL FROM SRB PLUME PRIOR TO AND AFTER SRB SEPARATION. SUN REFLECTS OFF ORBITER NOSE SHORTLY AFTER SRB SEPARATION.

**E-207** UCS-10 MIGOR tracking of launch vehicle from  
96 FPS acquisition to SRB separation. Tracks ET/ORB  
35mm after SRB separation to LOV.

Focus : OK  
F. O. V.: OK  
Exposure: OK

Comments: VEHICLE EXHIBITS TYPICAL ET AFT DOME CHARRING. BODY FLAP MOTION IS SIMILAR IN AMPLITUDE AND FREQUENCY TO OTHER ORBITERS ON PREVIOUS FLIGHTS. RCS PAPER COVERS ENTER MAIN ENGINE PLUME IN FRAME 99-10. FLASHES OCCUR IN MAIN ENGINE PLUME AT FRAME 104-15 AND 109-12. NUMEROUS PARTICLES FALL FROM RH SRB PLUME AT FRAME 228-09 AND 294-12.

**E-208** Cocoa Beach DOAMS tracking of launch vehicle  
48 FPS from acquisition to SRB separation. Tracks ET/ORB  
35mm after SRB separation to LOV.

Focus : OK  
F. O. V.: OK  
Exposure: OK

Comments: ET PLUME RECIRCULATION IS NORMAL. TYPICAL CHARRING OCCURS ON AFT DOME. SUN REFLECTS OFF ORBITER WINDOWS. SRB SEPARATION NORMAL.

**E-209** SHILOH IFLOT intermediate tracking of  
30 FPS launch vehicle from acquisition to LOV.  
70mm

Focus : OK  
F. O. V.: OK  
Exposure: OK

Comments: EXHAUST PLUME OBSCURES VIEW OF VEHICLE AFT. SRB SEPARATION IS NORMAL. VIEW BECOMES OBSCURED BY ATMOSPHERIC HAZE.

E-210 UCS-26 IFLOT intermediate tracking of  
30 FPS launch vehicle from acquisition to LOV.  
70mm

Focus : OK  
F. O. V.: OK  
Exposure: OK

Comments: ET AFT DOME CHARRING AND PLUME RECIRCULATION IS NORMAL. FLASHES OCCUR IN MAIN ENGINE PLUME. TPS PARTICLES FALL FROM LH SRB PLUME. SLAG FALLS FROM SRB PLUME PRIOR TO AND AFTER SRB SEPARATION.

E-211 UCS-13 IFLOT intermediate tracking of forward  
96 FPS portion of ORB and ET from acquisition to LOV.  
35mm

Focus : OK  
F. O. V.: OK  
Exposure: OK

Comments: CONDENSATE ON ET AFT DOME AND IN SRB STIFFENER RINGS VAPORIZES SHORTLY AFTER LIFTOFF. ET AFT DOME BEGINS TO CHAR PRIOR TO ROLL PROGRAM. VEHICLE DETAIL LOST DUE TO BACKLIGHTING.

E-212 UCS-23 MIGOR tracking of launch vehicle  
64 FPS from acquisition to LOV.  
35mm

Focus : OK  
F. O. V.: OK  
Exposure: OK

Comments: PLUME RECIRCULATION BEGINS AT FRAME 35-25. ET AFT DOME EXHIBITS TYPICAL CHARRING. OPTICAL DISTORTION PASSES THROUGH FOV AT FRAME 167-13 AND 195-00. FLASHES IN MAIN ENGINE PLUME OCCUR AT 66-08, 113-00, 121-11 THRU 125-00, 135-11 AND 179-03.

E-213 UCS-7 MOTS tracking of forward portion of ORB and  
96 FPS ET from acquisition to LOV.  
35mm

Focus : OK  
F. O. V.: OK  
Exposure: OK

Comments: A LEFT FORWARD RCS PAPER COVER COMES OFF AFTER ROLL PROGRAM. ET AFT DOME EXHIBITS TYPICAL CHARRING.

**E-217** Beach Road IFLOT close-in tracking of launch  
30 FPS vehicle during ignition, liftoff, and early  
70mm portion of flight through LOV.

Focus : OK  
F. O. V.: OK  
Exposure: OK

Comments: RCS PAPER COVER TEARS LOOSE AND IS PULLED INTO PLUME  
SHORTLY AFTER LIFTOFF. BRIGHT GLARE NEAR RIGHT SIDE CREW COMPART-  
MENT WINDOW IS SUNLIGHT REFLECTION. FLASHES OCCUR IN SSME PLUME.

**E-218** UCS-26 IFLOT intermediate tracking of  
96 FPS launch vehicle from acquisition through LOV.  
35mm

Focus : OK  
F. O. V.: OK  
Exposure: OK

Comments: INITIAL IMAGE DISTORTED DUE TO ATMOSPHERIC HAZE. ET  
AFT DOME CHARRING AND PLUME RECIRCULATION IS NORMAL. FLASHES IN  
MAIN ENGINE PLUME OCCUR AT FRAMES 207-06 THRU 209-01, AND 299-07.  
FRAME 399-03 PARTICLE FALLS FROM LH SRB PLUME. SRB SLAG FALLS  
FROM PLUME PRIOR TO AND AFTER SRB SEPARATION.

**E-219** UCS-3 IFLOT close-in tracking of launch  
30 FPS vehicle during ignition, liftoff, and early  
70mm portion of flight through LOV.

Focus :  
F. O. V.:  
Exposure:

Comments: DID NOT RUN.

**E-220** UCS-15 IFLOT close-in tracking of forward  
96 FPS portion of ORB and ET during ignition, liftoff,  
35mm and early portion of flight through LOV.

Focus : OK  
F. O. V.: OK  
Exposure: OK

Comments: BIRD PASSES THROUGH FOV BUT DOES NOT CONTACT VEHICLE. CONDENSATE VAPORIZES ON SRB STIFFENER RINGS SHORTLY AFTER LIFT-OFF. FORWARD RCS PAPER COVERS TEAR LOOSE PRIOR TO ROLL PROGRAM. FLASHES OCCUR IN MAIN ENGINE PLUME AT FRAME 254-01 AND 240-07. BODY FLAP MOTION IS SIMILAR TO THAT OBSERVED ON PREVIOUS MISSIONS. ET AFT DOME EXHIBITS TYPICAL CHARRING. THREE PARTICLES FALL FROM LH SRB PLUME AT FRAME 421-05. PLUME OBSCURES AFT VIEW OF VEHICLE. SRB SEPARATION APPEARS NOMINAL.

E-221 UCS-3 IFLOT close-in tracking of forward portion  
96 FPS of ORB and ET during ignition, liftoff, and early  
35mm portion of flight through LOV.

Focus : OK  
F. O. V.: OK  
Exposure: OK  
Note : EXCESSIVE CAMERA SHAKE

Comments: A BIRD TAKES OFF FROM THE FSS AND FLIES AWAY FROM THE VEHICLE IN A NORTHERLY DIRECTION. CONDENSATE VAPORIZES ON THE SRB STIFFENER RINGS SHORTLY AFTER LIFTOFF. CHARRING OCCURS ON THE ET AFT DOME PRIOR TO ROLL PROGRAM. ICE PARTICLES FALL FROM ET/ORBITER UMBILICALS. PARTICLES FALL OUT OF LH SRB PLUME AT FRAMES 450-08, 459-02, AND 460-02. ORANGE FLASHES APPEAR IN SSME PLUME AT FRAME 362-03. SRB SEPARATION NOMINAL.

E-222 Beach Road IFLOT close-in tracking of forward  
96 FPS portion of ORB and ET during ignition, liftoff,  
35mm and early portion of flight through LOV.

Focus : OK  
F. O. V.: OK  
Exposure: OK

Comments: AN RCS PAPER COVER TEARS LOOSE AND IS PULLED INTO PLUME SHORTLY AFTER LIFTOFF. BRIGHT GLARE NEAR RIGHT SIDE CREW COMPARTMENT WINDOW IS SUNLIGHT REFLECTION. ET AFT DOME EXHIBITS TYPICAL CHARRING. FORWARD RCS PAPER COMERS TEAR LOOSE AT BEGINNING OF ROLL PROGRAM. FLASHES OCCUR IN SSME PLUME FRAME 274-13.

E-223 UCS-9 IFLOT intermediate tracking of forward  
96 FPS portion of ORB and ET during ignition, liftoff,  
35mm and early portion of flight through LOV.

Focus : OK  
F. O. V.: OK  
Exposure: OK

Comments: HYDROGEN VENT ARM RETRACTION/LATCH APPEARS NOMINAL.  
ICE PARTICLES FALL FROM THE ET/ORBITER UMBILICALS AND DO NOT  
CONTACT VEHICLE. PAPER FROM FORWARD RCS IS TORN LOOSE AND PASSES  
THROUGH SSME PLUME IN FRAME 110-00. TWO PARTICLES FALL FROM SRB  
PLUME IN FRAME 477-04. TRACKING IS LOST SHORTLY AFTER ROLL  
PROGRAM

E-224 UCS-6 IFLOT close-in tracking of entire launch  
100 FPS vehicle during ignition, liftoff, and early flight  
35mm through LOV.

Focus : OK  
F. O. V.: OK  
Exposure: OK

Comments: FORWARD RCS PAPER COVERS TEAR LOOSE AT BEGINNING OF  
ROLL PROGRAM. CONDENSATE VAPORIZES AND TPS ON ET AFT DOME CHARS  
AFTER ROLL PROGRAM.

E-233L Castglance airborne tracking  
35mm

Focus : OK  
F. O. V.: OK  
Exposure: OK

Comments: NOSECAP, FRUSTUM, AND PARACHUTE DEPLOYMENT NOMINAL.  
CHUFFING VISIBLE. SRB LOST IN CLOUDS, REACQUIRED AFTER SPLASH-  
DOWN.

E-233R Castglance airborne tracking  
16mm

Focus : OK  
F. O. V.: OK  
Exposure: OK

Comments: SEE FILM ITEM E-233L. OBSERVED LEFT SRB ON SPLASHDOWN.



**VIDEO ITEMS**

**OTV 101** Views aft end of Orbiter from the FSS 255 foot  
B/W M-II level.

Comments: RESIDUAL VAPORS ARE VISIBLE FROM FLIGHT QD. LO2 T-0  
UMBILICAL RETRACTION IS NORMAL.

**OTV 103** Views GUCP and GH2 vent line.  
B/W M-II

Comments: ICE PARTICLES FALL FROM GH2 VENT LINE AT LIFTOFF.  
RESIDUAL VAPORS IN GH2 VENT LINE.

**OTV-109** Views ET/Orbiter LH2 umbilical area from the 95  
B/W M-II foot level of the FSS.

Comments: PURGE VENTING NORMAL. ICE PARTICLES FALL FROM UMBILI-  
CALS. SMALL PIECE OF PAPER PULLED IN BY ASPIRATION.

**OTV 141** Views and tracks vehicle from camera site 2.  
B/W

Comments: SSME IGNITION AND LIFTOFF NOMINAL. TRACKING LOST AFTER  
ROLL PROGRAM DUE TO CLOUDS.

**OTV 143** Views east side of launch vehicle and pad from  
B/W camera site 2.

Comments: CAMERA POINTED AT CROSS COUNTRY LINES.

**OTV 148** Launch and tracking view from camera site 6.  
B/W

Comments: GH2 VENT LINE HAUNCH DELUGE BLOWN WEST. CONDENSATE  
VAPORIZES ON ET AFT DOME. TRACKING LOST DUE TO CLOUDS.

**OTV 149** Views Orbiter LO2 T-0 umbilical from MLP deck.  
B/W M-II

**Comments:** ICE PARTICLES FALL FROM T-0 UMBILICAL AT SSME IGNITION. RCS PAPER COVERS TEAR AND ARE PULLED INTO THE PLUME BY ASPIRATION. NO RESIDUAL VAPORS WERE EVIDENT FROM T-0 UMBILICAL.

**OTV 150** Views Orbiter LH2 T-0 umbilical from SW MLP deck.  
B/W M-II

**Comments:** ICE PARTICLES FALL FROM LH2 T-0 UMBILICAL AT SSME IGNITION. RESIDUAL VAPORS VISIBLE FROM LH2 T-0 UMBILICAL. UMBILICAL RETRACTION NORMAL.

**OTV 151** Views main engine cluster.  
B/W M-II

**Comments:** ICE PARTICLES FALL FROM ET/ORBITER UMBILICALS.

**OTV 154** Views ET/Orbiter LO2 umbilical and Orbiter RH wing  
B/W M-II

**Comments:** ICE PARTICLES FALL FROM ET/ORBITER UMBILICALS DURING SSME IGNITION.

**OTV 155** Views LH SRB and underside of Orbiter RH wing.  
B/W M-II

**Comments:** ICE PARTICLES FALL FROM ET/ORBITER UMBILICALS AT SSME IGNITION AND THRU EARLY ASCENT.

**OTV 156** Views RH SRB and underside of Orbiter LH wing.  
B/W M-II

**Comments:** ICE PARTICLES FALL FORM ET/ORBITER UMBILICALS AT SSME IGNITION AND THRU EARLY ASCENT.

OTV 160 Views ET nosecone and NE louver from water tower.  
Color M-II

Comments: LOUVER AREA IS COVERED BY LIGHT FROST. NO TPS DAMAGE.  
GH2 VENT ARM LATCH NOMINAL. CONDENSATE VAPORIZES ON ET.

OTV 161 Views ET nosecone and SW louver from the FSS.  
Color M-II

Comments: LOUVER AREA IS COVERED BY LIGHT FROST. TWANG IS  
NOMINAL.

OTV 163 Views ET/Orbiter umbilical and Orbiter T-0  
Color M-II umbilical from the FSS.

Comments: SSME IGNITION NOMINAL. ICE PARTICLES FALL FROM  
ET/ORBITER UMBILICALS, FEED LINE BELLOWS, AND -Y LONGERON/THRUST  
STRUT AREA CAUSING NO APPARENT TILE DAMAGE. T-0 UMBILICAL RETRAC-  
TION NOMINAL.

OTV 170 Views overall vehicle from SE direction.  
Color M-II

Comments: SSME IGNITION NOMINAL. RCS PAPER COVERS TEAR LOOSE. NO  
RESIDUAL VAPORS FROM LO2 T-0 DISCONNECT. ICE PARTICLES FALL FROM  
ET/ORBITER UMBILICALS.

OTV 171 Views overall vehicle from SW direction.  
Color M-II

Comments: PLUME OBSCURES VEHICLE.

STI (C/S 2) Infrared view from camera site 2.  
B/W M-II

Comments: FREE HYDROGEN BURNS UNDER BODY FLAP UNTIL PLUME STABI-  
LIZES. SSME IGNITION APPEARS NORMAL.

**STI (RSS)** Infrared view from RSS roof.  
B/W M-II

Comments: IR SIGNATURE OF SSME IGNITION IS NORMAL.

**TV-2** Views entire launch vehicle from camera site 7  
Color M-II east of Pad B.

Comments: TOO DISTANT FOR DETAIL. NO ANOMALIES.

**TV-3** Views entire launch vehicle from camera site 9  
Color M-II

Comments: NOT AVAILABLE.

**TV-4** Views entire vehicle from Beach Road IFLOT Site.  
Color M-II

Comments: SSME IGNITION NORMAL. SLIGHT OVERSHOOT ON ROLL. SUN REFLECTS OFF WINDOW #6 AT START OF ROLL. MOMENTARY GLARE APPEARS ON LENS AT ALTITUDE.

**TV-5** Views launch from VAB roof.  
Color M-II

Comments: SSME IGNITION NORMAL.

**TV-7** Views entire launch vehicle from camera site 2  
Color M-II east of pad.

Comments: SSME IGNITION NORMAL. CONDENSATE VAPORIZES ON ET AFT DOME.

**TV-11** Views launch from SLF.  
Color M-II

Comments: TOO DISTANT FOR DETAIL.

**TV-13** Cocoa Beach DOAMS video. Tracks launch vehicle  
Color M-II from acquisition to LOV.

Comments: ACQUIRED IN FLIGHT. PLUME RECIRCULATION NORMAL. SUN REFLECTS OFF CABIN WINDOWS. BSM FIRING NOMINAL. NUMEROUS PARTICLES (CLINKERS) APPEAR IN SRB PLUME AFTER SEPARATION.

**TV-16** View from helicopter orbiting west of pad and VAB.  
Color M-II

Comments: CAMERA POINTED AT PAD A AT T-0. TRACKING LOST DUE TO CLOUDS. VIEW TOO DISTANT.

**TV-18** Malabar ITEC video. Tracks launch vehicle from  
Color M-II acquisition to LOV.

Comments: PLUME RECIRCULATION NORMAL.

**TV-21** Views entire launch vehicle from DLTR-3 site  
Color M-II directly south of Pad B.

Comments: TOO DISTANT FOR DETAIL.

**ET-204** Patrick IGOR video. Tracks launch vehicle from  
Color M-II acquisition to LOV.

Comments: IMAGE IS GENERALLY HAZY. PLUME RECIRCULATION AND SRB SEPARATION NORMAL. SEVERAL SLAG PARTICLES FALL FROM THE SRB AFTER SEPARATION.

**ET-206** Melbourne Beach ROTI video. Tracks launch vehicle  
Color M-II from acquisition to LOV.

Comments: PLUME RECIRCULATION IS NORMAL. SLAG PARTICLES FALL FROM THE SRB BEFORE AND AFTER SEPARATION.

**ET-207** UCS-10 MIGOR video. Tracks launch vehicle from  
Color M-II acquisition to LOV.

Comments: CONDENSATE VAPORIZES ON THE ET AFT DOME. VEHICLE OVERSHOTS THE ROLL MANEUVER SLIGHTLY. VIEW IS OBSCURED BY CLOUDS MOST OF THE ASCENT. SRB SEPARATION IS NORMAL.

**ET-208** Cocoa Beach DOAMS video. Tracks launch vehicle  
Color M-II from acquisition to LOV.

Comments: PLUME RECIRCULATION IS NORMAL. SUN REFLECTS OFF THE ORBITER WINDOWS.

**ET-212** UCS-23 MIGOR video. Tracks launch vehicle from  
Color M-II acquisition to LOV.

Comments: GOOD TRACKING AND EXPOSURE INITIALLY, BUT EXPOSURE BECOMES WORSE (OVEREXPOSED). SRB SEPARATION IS NORMAL. SLAG PARTICLES FALL FROM THE SRB BEFORE AND AFTER SEPARATION.

**ET-213** UCS-3 MOTS video. Tracks launch vehicle from  
Color M-II acquisition to LOV.

Comments: VIEW MOSTLY OBSCURED BY CLOUDS. POOR TRACKING.

## 7.2 ON-ORBIT FILM DATA REVIEW

THERE WERE NO ON-ORBIT FILM ITEMS FOR THIS MISSION.

## 7.3 LANDING FILM DATA REVIEW

**E-1005**                      Orbiter landing at Ames-Dryden Flight Research  
16mm                              Facility

Focus     :   OK  
F. O. V.:   OK  
Exposure:   OK

Comments:   VEHICLE TO DISTANT FOR DETAIL.

**E-1008**                      Orbiter landing at Ames-Dryden Flight Research  
16mm                              Facility

Focus     :   OK  
F. O. V.:   OK  
Exposure:   OK

Comments:   NO VEHICLE ANOMALIES.

**E-1011**                      Orbiter landing at Ames-Dryden Flight Research  
35mm                              Facility

Focus     :   OK  
F. O. V.:   OK  
Exposure:   OK

Comments:   TRACKING IS SHAKY. LH AND RH MLG TOUCH DOWN SIMUL-  
TANEOUSLY.

**E-1012**                      Orbiter landing at Ames-Dryden Flight Research  
35mm                              Facility

Focus     :   OK  
F. O. V.:   OK  
Exposure:   OK

Comments:   TRACKING IS SHAKY. LH AND RH MLG TOUCH DOWN SIMUL-  
TANEOUSLY.

**E-1017**                   Orbiter landing at Ames-Dryden Flight Research  
35mm                   Facility

Focus       :   OK  
F. O. V.:   OK  
Exposure:   OK

Comments:   NO ANOMALIES

**E-1019**                   Orbiter landing at Ames-Dryden Flight Research  
16mm                   Facility

Focus       :   OK  
F. O. V.:   OK  
Exposure:   OK

Comments:   VEHICLE TO DISTANT FOR DETAIL.

**E-1027**                   Orbiter landing at Ames-Dryden Flight Research  
16mm                   Facility

Focus       :   OK  
F. O. V.:   OK  
Exposure:   OK

Comments:   TRACKING PROBLEMS.   SEE FILM ITEM E-1011.



## 8.0 SRB POST FLIGHT/RETRIEVAL DEBRIS ASSESSMENT

Both Solid Rocket Boosters were inspected for debris damage and debris sources at CCAFS Hangar AF on 26 April 1990 from 0800 to 1200 hours.

### 8.1 RH SOLID ROCKET BOOSTER DEBRIS INSPECTION

The nose cap was not recovered. The RH frustum had no areas of missing TPS but had 5 debonds over fasteners (Figure 11). The Hypalon paint had blistered slightly in localized areas. Some layers of MSA had adhered to the paint. The BSM covers were fully opened and locked in the 180 degree position.

The RH forward skirt exhibited no debonds or missing TPS. The phenolic plate on the -Z RSS antenna had some delaminated layers (Figure 12). Separation of the forward attach bolt appeared normal. K5NA closeouts on the inboard corners of the RSS interface cable tray were intact.

All field joint cork closeouts were undamaged. Minor trailing edge damage to the FJS and GEI cork runs were attributed to debris hits from nozzle extension severance.

K5NA closeouts on the IEA covers were intact, though Hypalon paint had blistered in localized areas. Some TPS was missing aft of the ETA ring. Separation of the aft ET/SRB struts appeared nominal. An 18 inch crack in the aft stiffener ring K5NA closeout and EPDM moisture seal was caused by water impact.

The TPS over the aft skirt acreage was generally in good condition (Figure 13). K5NA was missing from all four aft BSM nozzles. The TVC system appeared to be undamaged. The phenolic material on the kick ring delaminated in several locations. K5NA thermal protective domes were missing from bolt heads on the aft side of the kick ring. A 16 x 2.4 inch maximum width piece of closeout cork was missing from the aft segment/aft skirt joint. This was considered to be an adhesive failure due to the unsooted substrate. Instafoam was missing from the aft ring around the aft skirt feet, HPU exhaust horns, and the SRB T-0 umbilical.

Debris Containment System (DCS) plungers for HDP #2, 3, and 4 were properly seated and latched, but a frangible nut fragment prevented the HDP #1 plunger from seating. There was no broaching of any post holes. There were two small 2-inch diameter sooted areas where the HDP #3 Epon shim material was missing. Twenty to thirty percent of the HDP #4 Epon shim material was missing with sooted substrate.

FIGURE 11. RIGHT SRB FRUSTUM

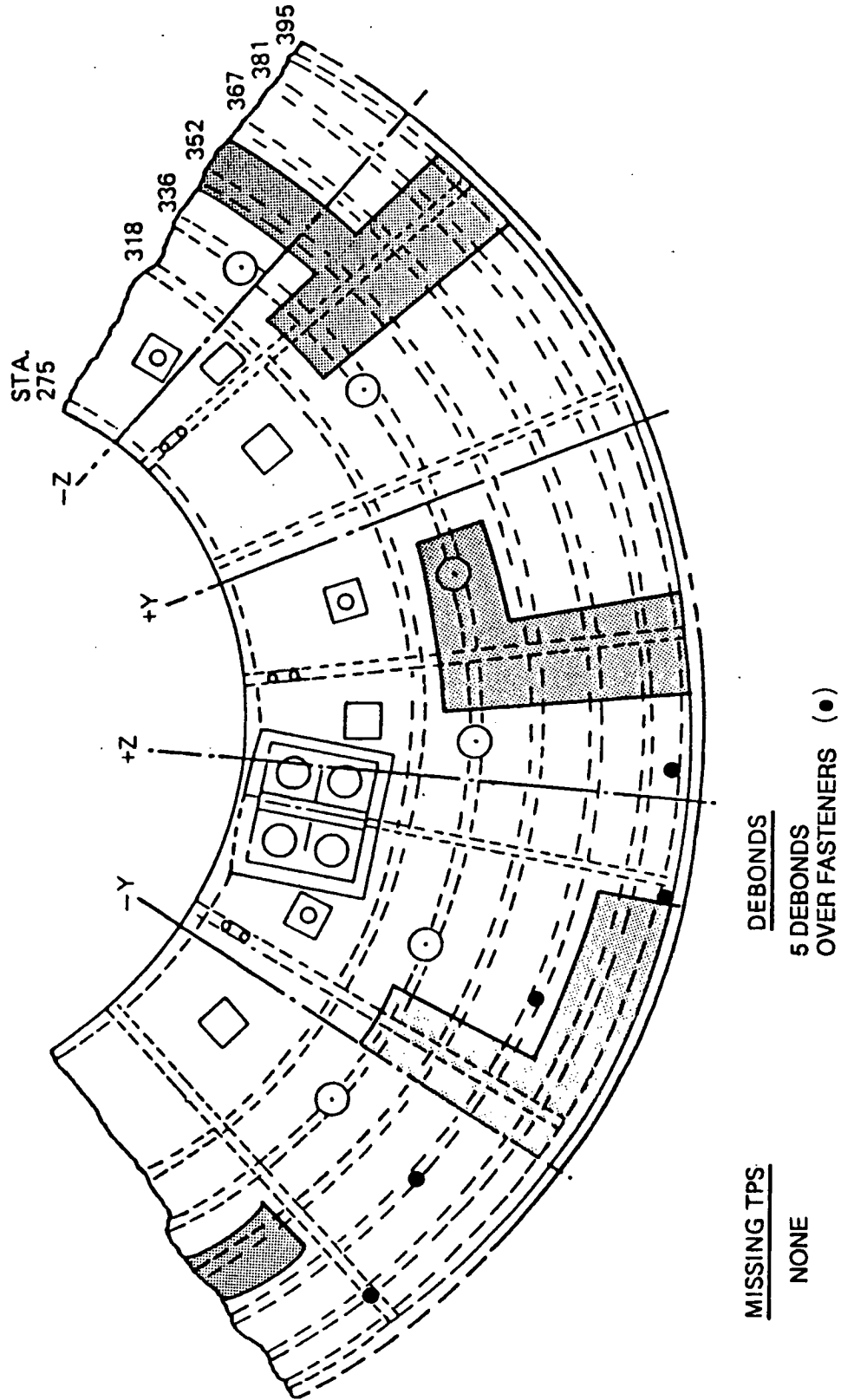

FIGURE 12. RIGHT SRB FWD SKIRT

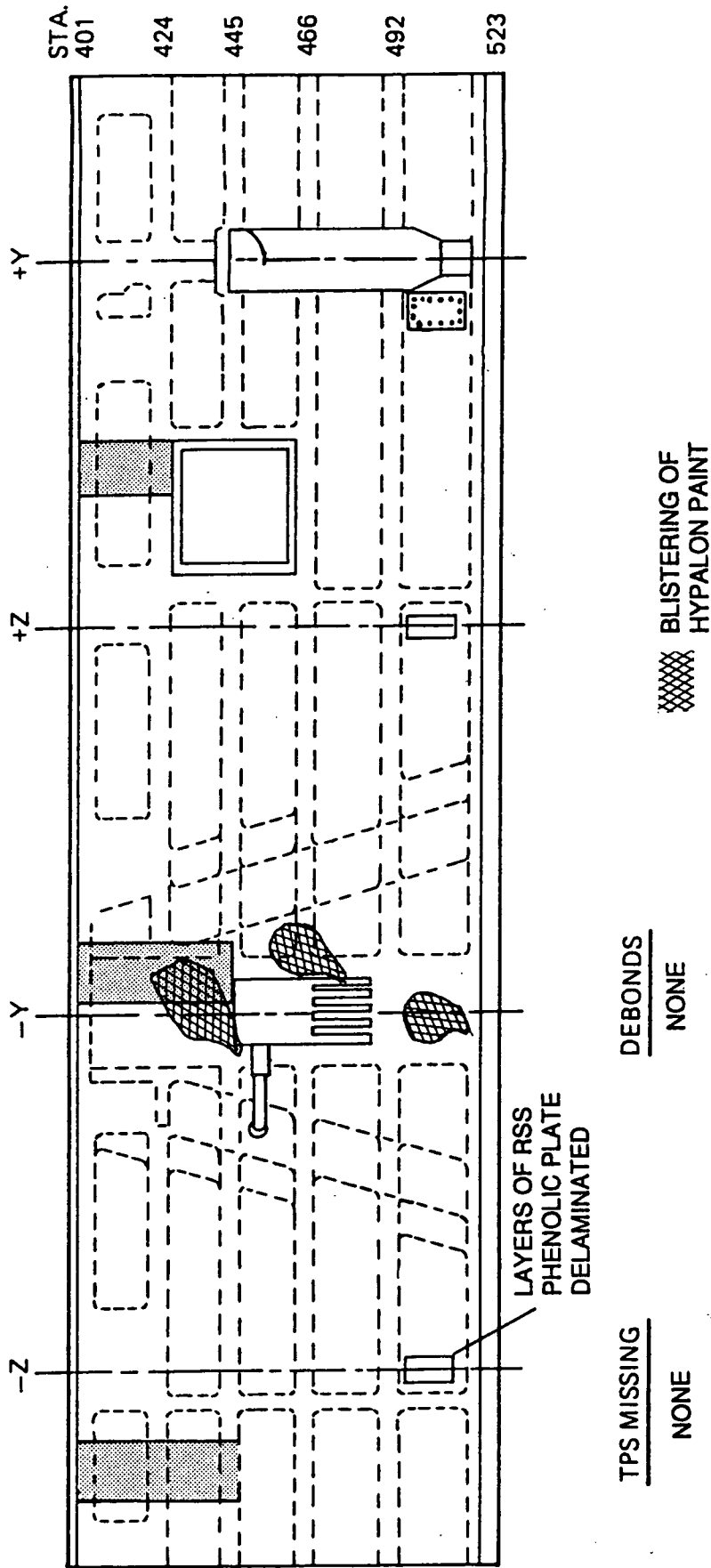
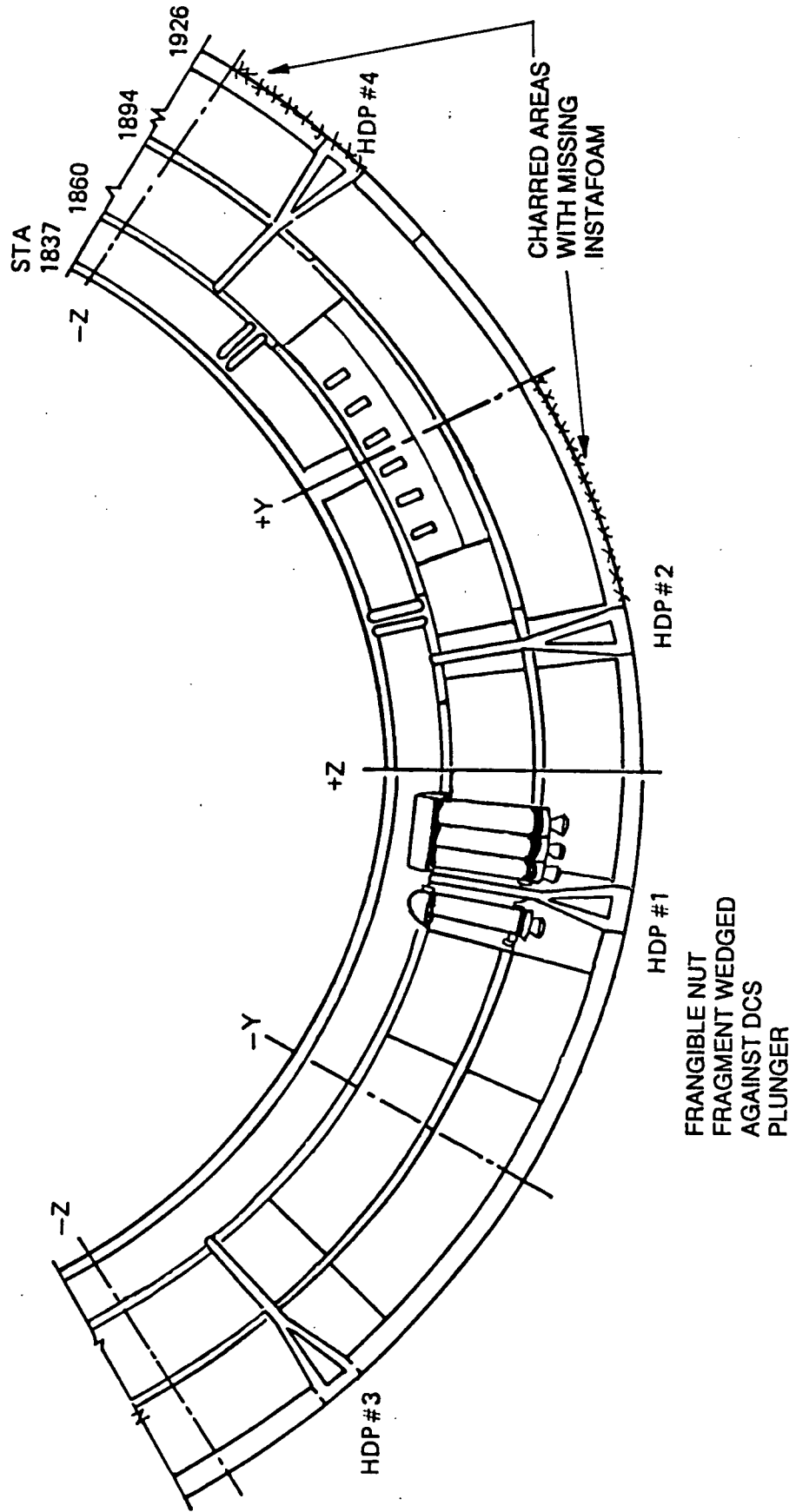

FIGURE 13. RIGHT SRB AFT SKIRT EXTERIOR TPS



## 8.2 LH SOLID ROCKET BOOSTER DEBRIS INSPECTION

The nose cap was not recovered. The LH frustum exhibited no missing TPS but had 7 debonds over fasteners (Figure 14). There was minor blistering of the Hypalon paint in localized areas. The BSM covers were fully opened and locked in the 180 degree open position.

The LH forward skirt exhibited no missing TPS or debonds. Localized areas of Hypalon paint blistered with layers of MSA-2 attached to the paint (Figure 15). Separation of the forward attach bolt was nominal and the RSS cables separated cleanly. The K5NA closeouts on the inboard corners of the RSS interface cable tray were intact.

The field joint cork closeouts were undamaged except for three cracks at the following locations:

- 1) center field joint      150 degrees      0.70 inches long
- 2) center field joint      150 degrees      0.75 inches long
- 3) aft field joint          150 degrees      1.20 inches long

Minor trailing edge damage to the JPS and GEI cork runs was attributed to debris hits from the nozzle extension severance.

Separation of the aft ET/SRB struts appeared nominal. The LH Integrated Electronics Assembly (IEA) was found floating in the water, but still attached to the SRB by electrical cables. Damage to the IEA and separation from the ETA ring was not related to any debris issues.

Two debonds occurred on the aft edge of the LH aft segment stiffener to stiffener factory joint EPDM seal: 320 degrees, 1" long, 0.16 inch depth; 315 degrees, 0.5 inch long, 0.1 inch depth.

The TPS over the aft skirt acreage was generally in good condition (Figure 16). The phenolic material on the kick ring delaminated in several locations. Two K5NA protective domes were missing from bolt heads on the aft side of the kick ring with sooted substrate. K5NA was missing from all four BSM nozzles. The TVC system appeared to be undamaged. Instafoam was missing from the aft ring around the skirt feet, HPU exhaust horns, and the SRB T-0 umbilical.

All four DCS plungers were seated and latched. HDP #7 Epon shim exhibited some material loss, but not to substrate.

FIGURE 14. LEFT SRB FRUSTUM

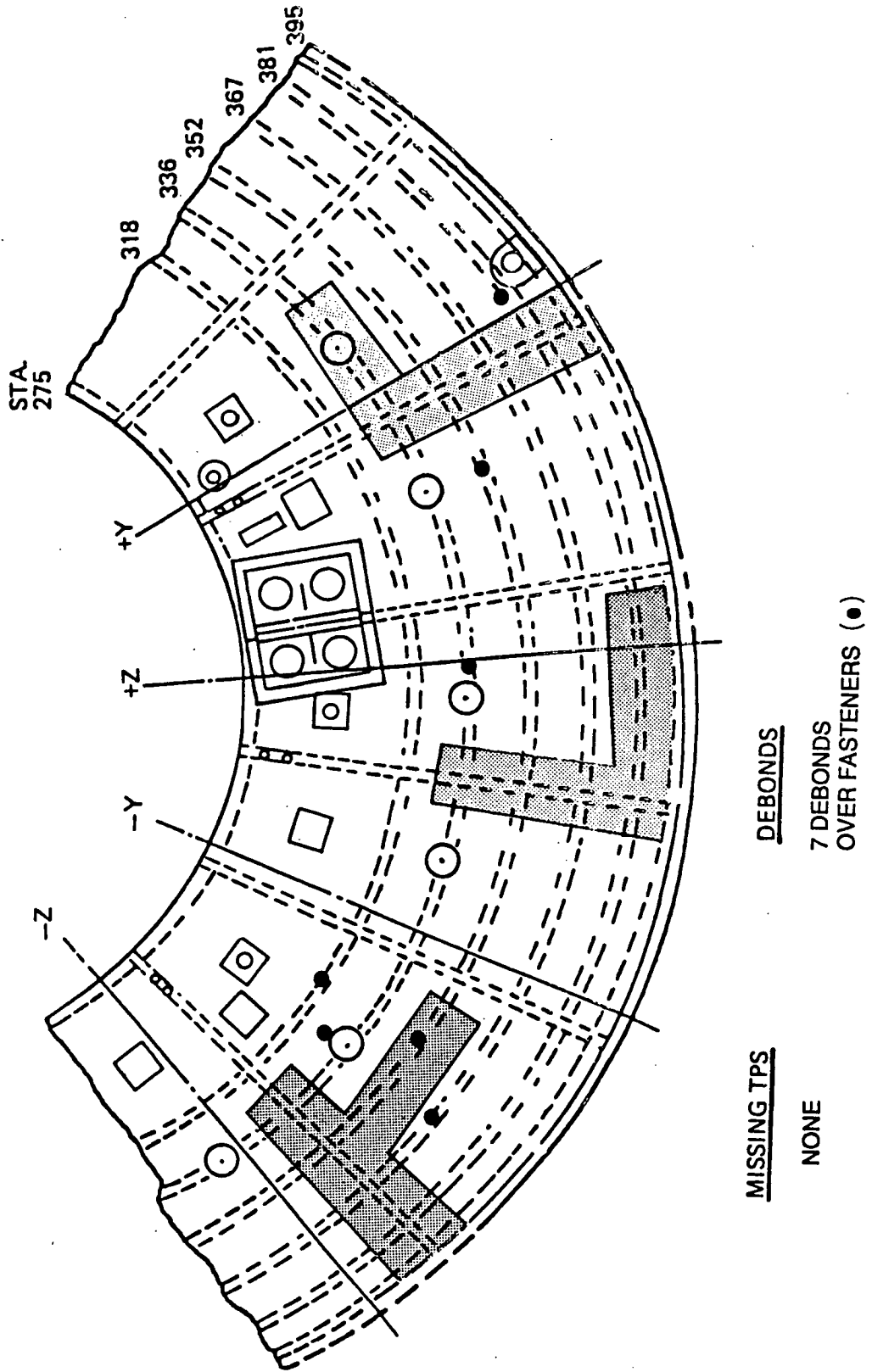

FIGURE 15. LEFT SRB FWD SKIRT

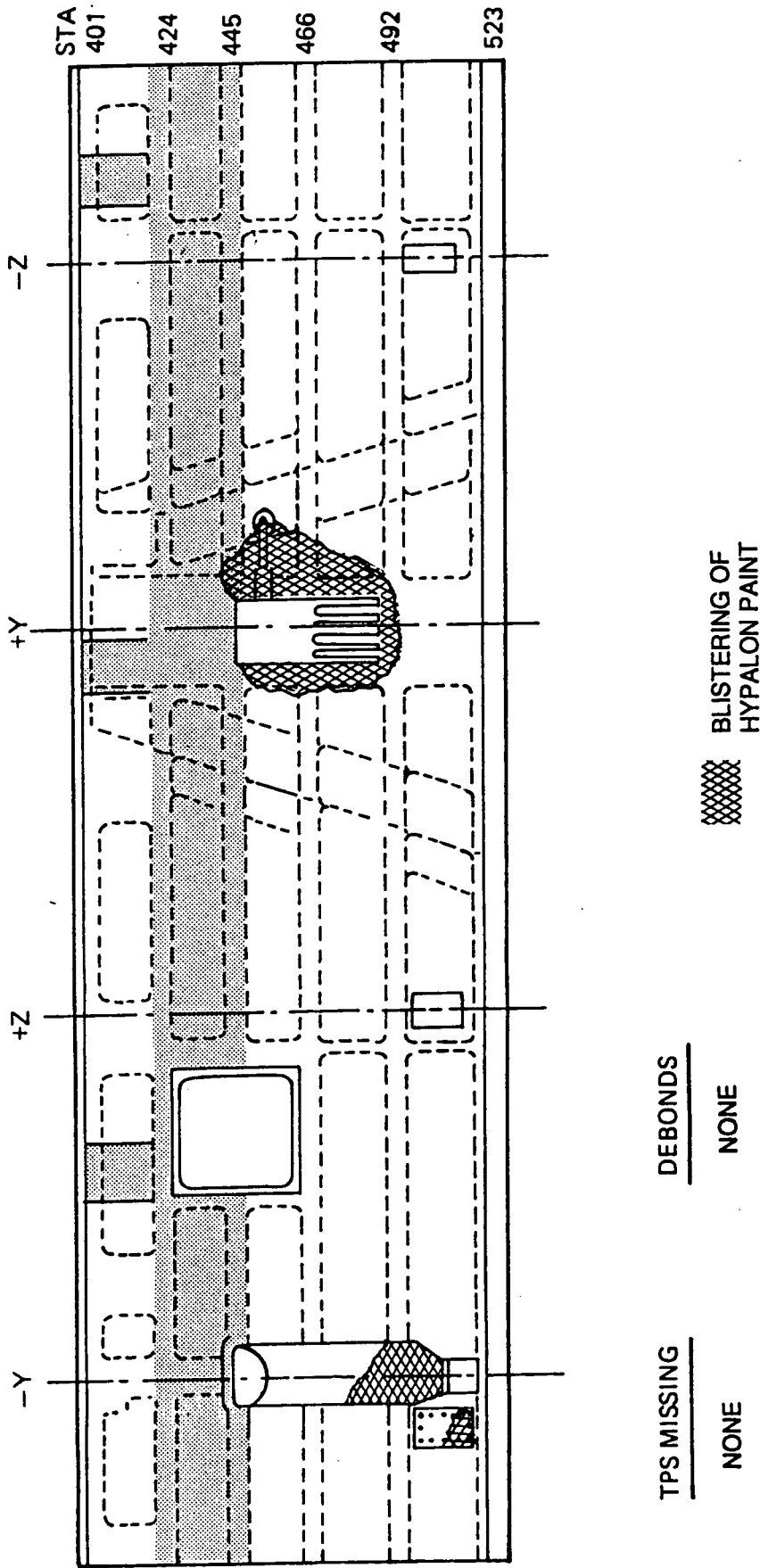
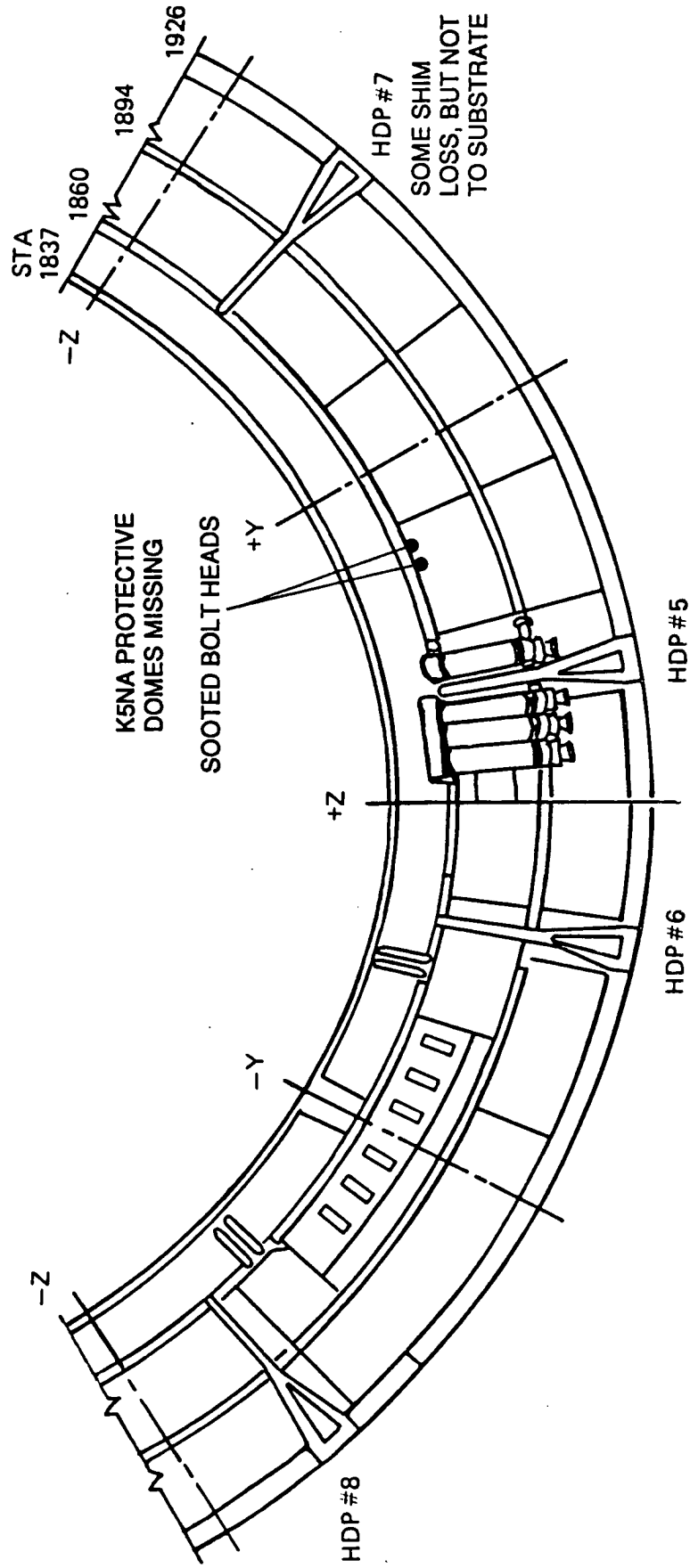

FIGURE 16. LEFT SRB AFT SKIRT EXTERIOR TPS



1) ALL FOUR DCS PLUNGERS WERE SEATED



### 8.3 RECOVERED SRB DISASSEMBLY FINDINGS

The percentage of potential debris retained in the DCS was measured, but the total does not include the frangible nut halves:

HDP #1	11.7%	HDP #5	96.9%
HDP #2	99.8%	HDP #6	97.4%
HDP #3	91.0%	HDP #7	99.0%
HDP #4	89.1%	HDP #8	96.8%

The LH IEA had been found floating in the water, but was still attached to the SRB by electrical cables. The IEA was examined by the MAB lab and appeared to have broken off due to water impact loads. All of the IEA covers had separated from the IEA and were not recovered. The ETA ring forward web cap was deformed at the IEA location.

Both forward skirt-to-frustum severance rings had been removed before a detailed assessment was performed on the safety wired pins. Technician interviews indicated no anomalies existed, but this does not substitute for an engineering assessment.

There were two blowholes in the igniter-to-forward segment case putty: 252 degrees in the LH igniter and 180 degrees in the RH igniter. Light corrosion occurred on the forward dome boss in the LH blowhole. Corrosion with pitting (0.002 inch depth max) on the forward dome boss was present in the RH blow holes and was similar to the STS-33R findings. Thiokol will study the dome boss corrosion.

There are two gaskets per igniter - inner and outer. Each gasket has a primary and secondary seal. Sooting occurred on the LH inner gasket on the OD edge and aft face from 110-0-40 degrees, and on the ID edge and aft face from 144-351 degrees on the LH outer gasket. The RH inner gasket was sooted on the OD edge and aft face over the full circumference while the outer gasket was sooted on the ID edge from 117-0-18 degrees. No soot was visible past any seal.

SRB Post Launch Anomalies are listed in Section 11.3.

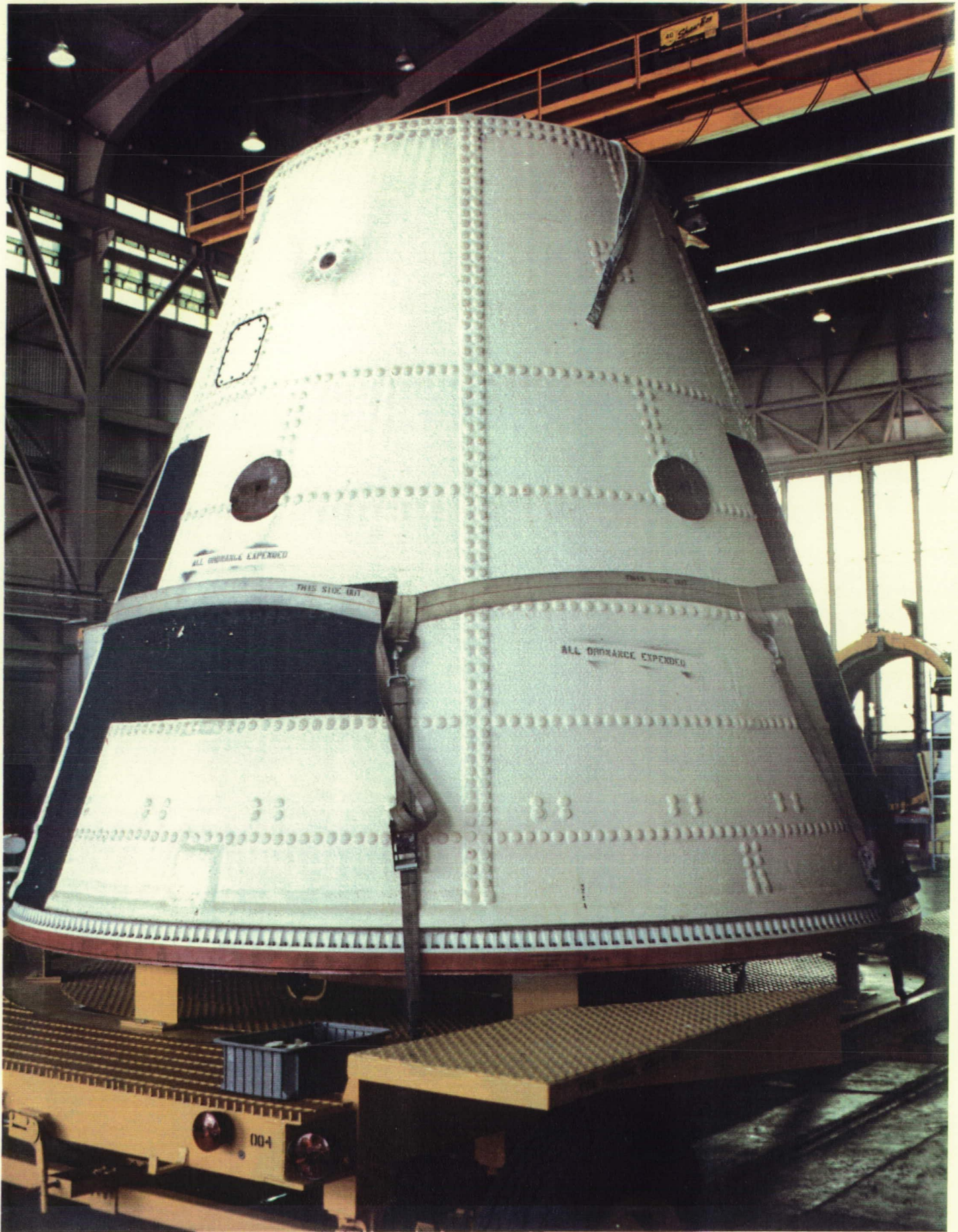

Post flight condition of RH frustum. There were 5 debonds over fasteners, but no areas of missing TPS.

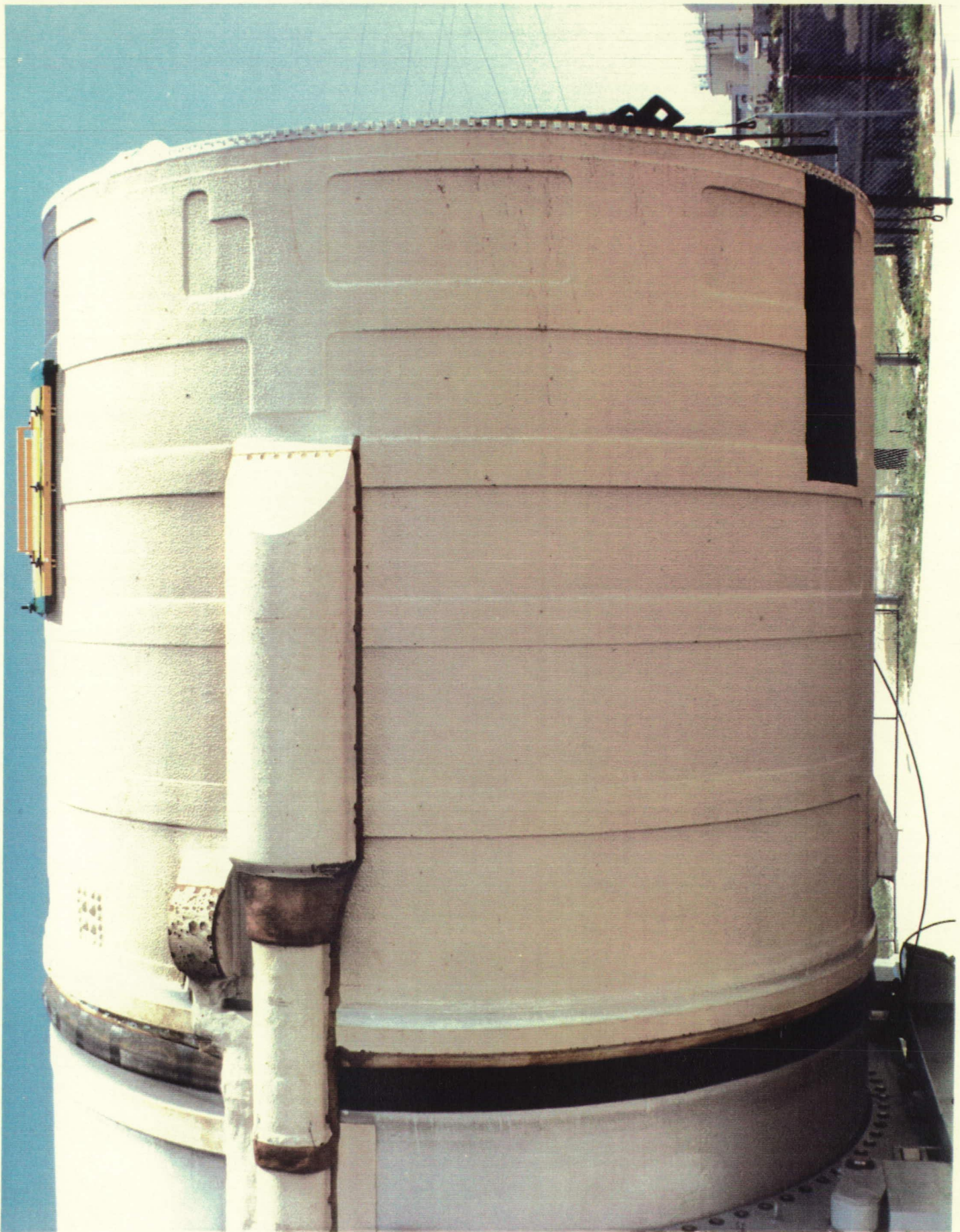

Post flight condition of RH forward skirt. There were no debonds or areas of missing TPS



Localized areas of Hypalon paint blistered with some layers of  
MSA-2 adhering to the paint



The phenolic plate on the -Z RSS antenna had some delaminated layers

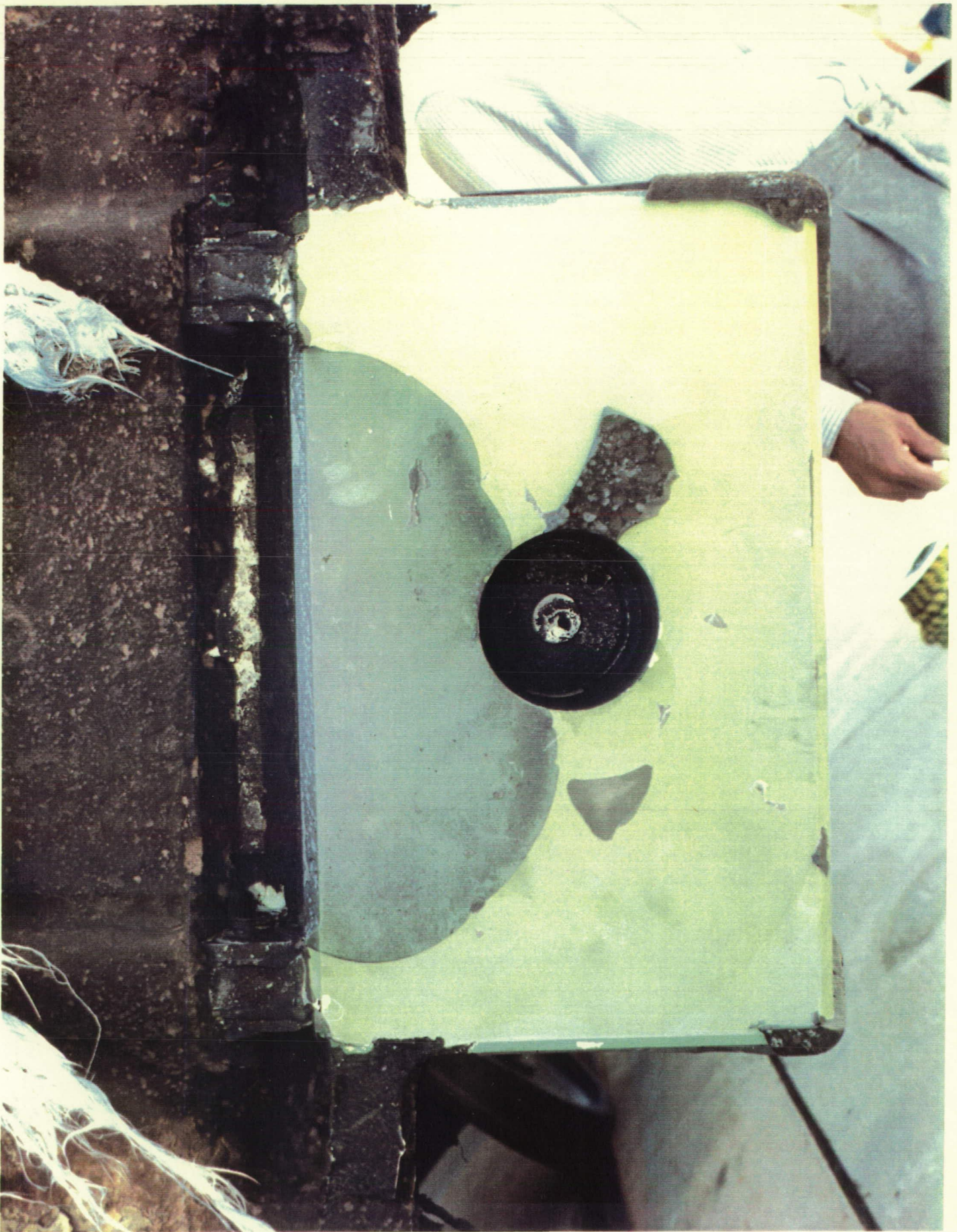

Some of the Epon shim material on HDP #4 was missing prior  
to water impact

121

ORIGINAL PAGE IS  
OF POOR QUALITY

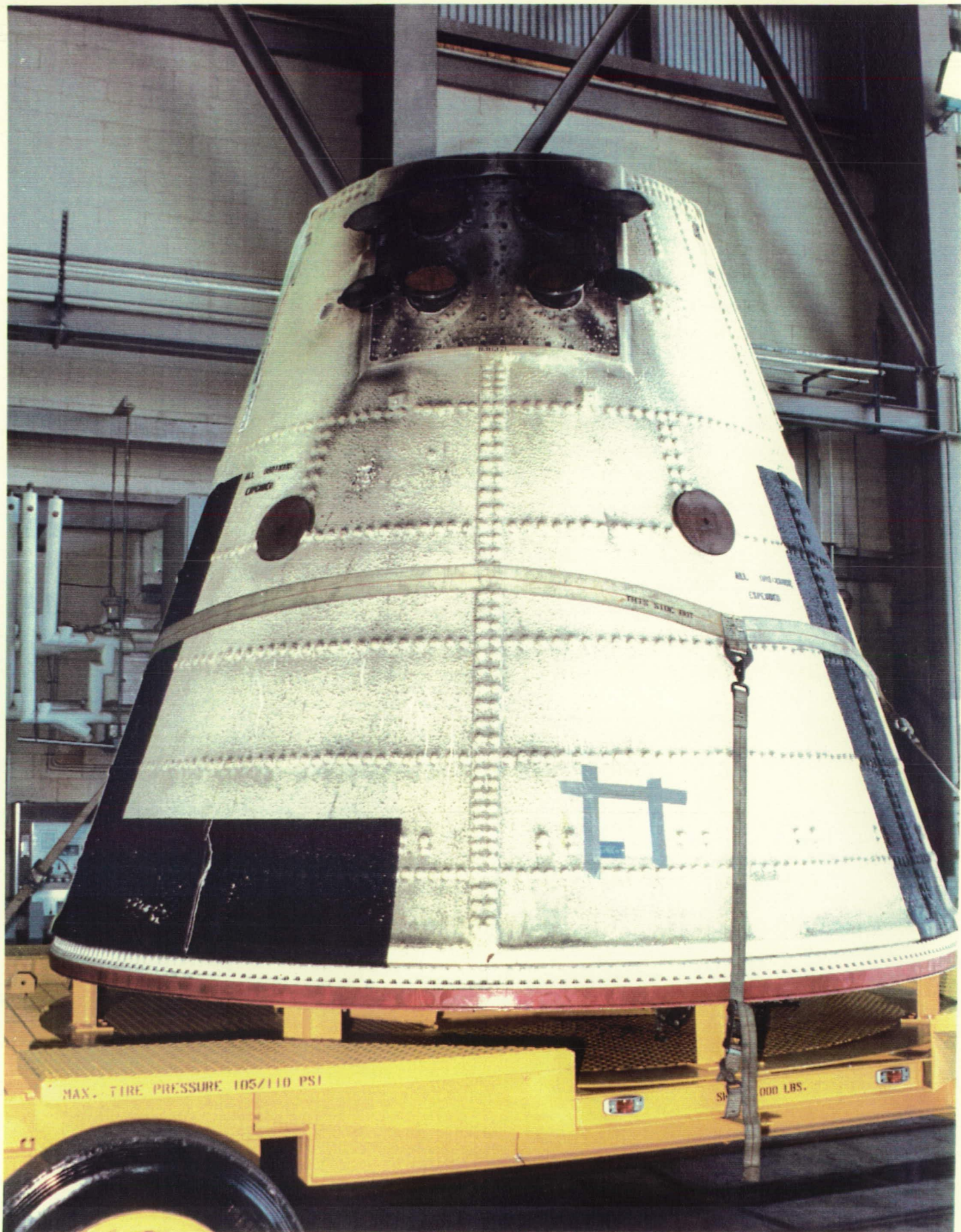

Post flight condition of the LH frustum. There were 7 debonds over fasteners, but no areas of missing TPS.

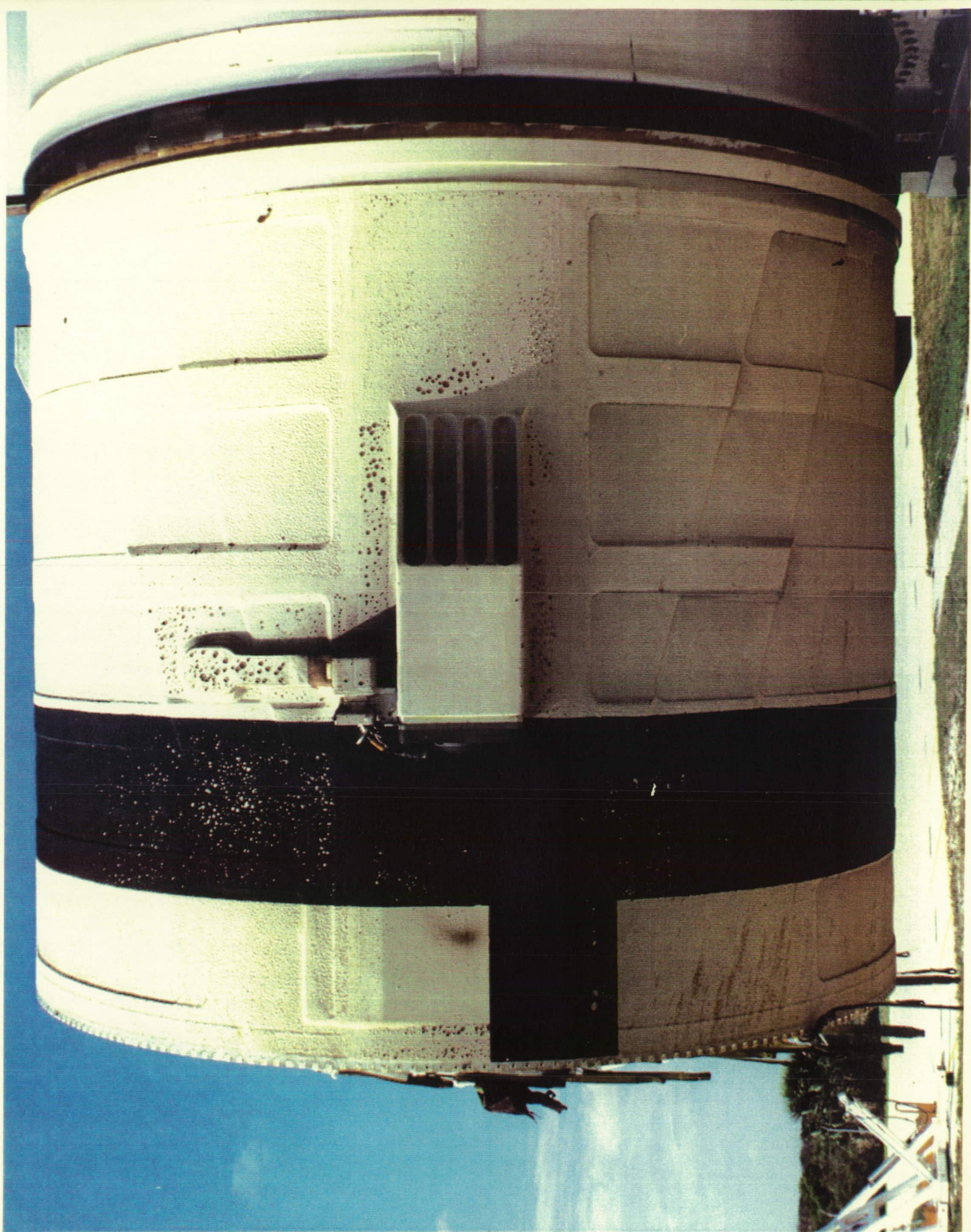

Post flight condition of the LH forward skirt. There were no debonds or areas of missing TPS.





Layers of MSA-2 adhering to Hypalon paint blisters increases the mass of the paint chips and causes tile damage

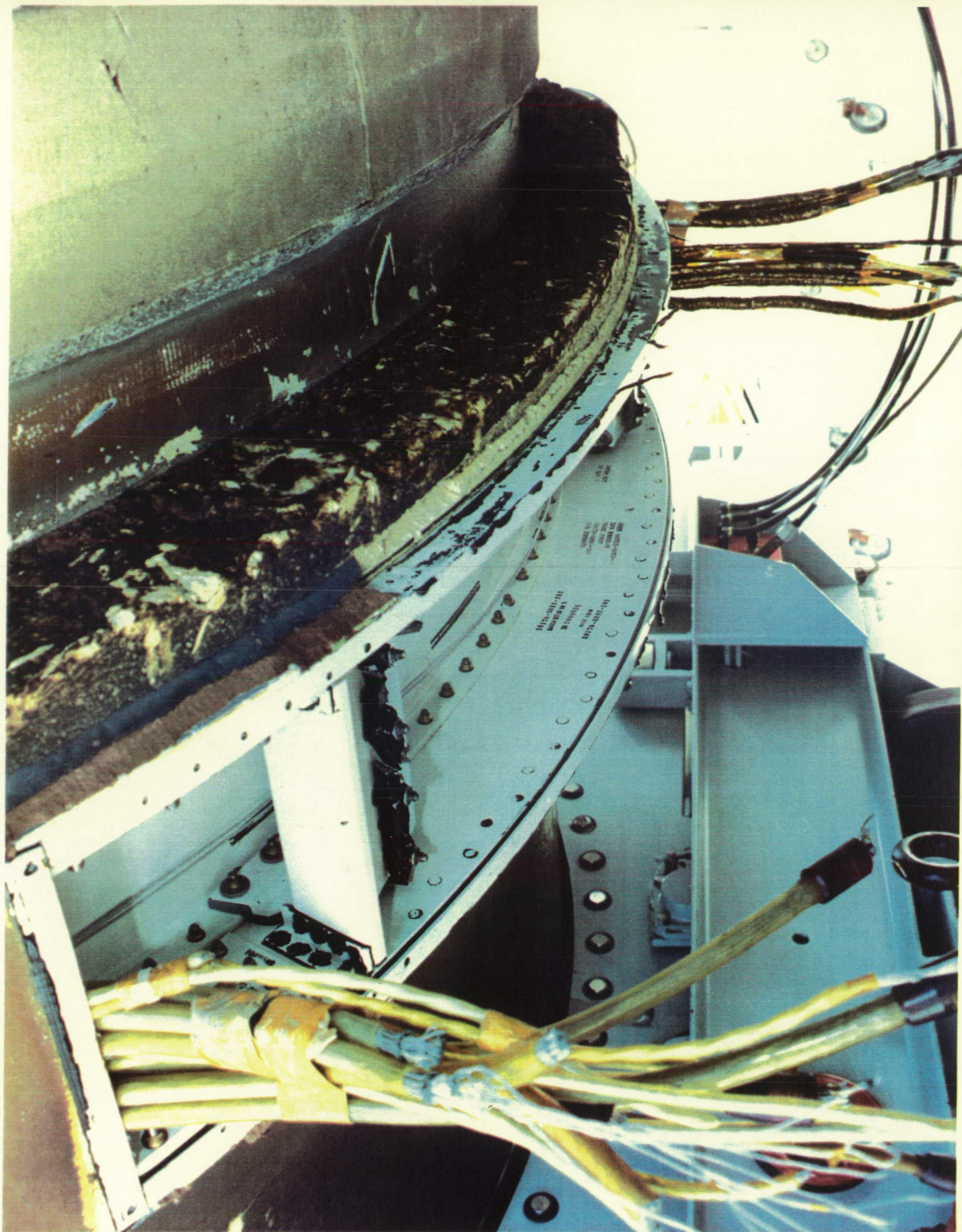

Loss of the LH IEA from the ETA ring at water impact was not attributed to any debris issues

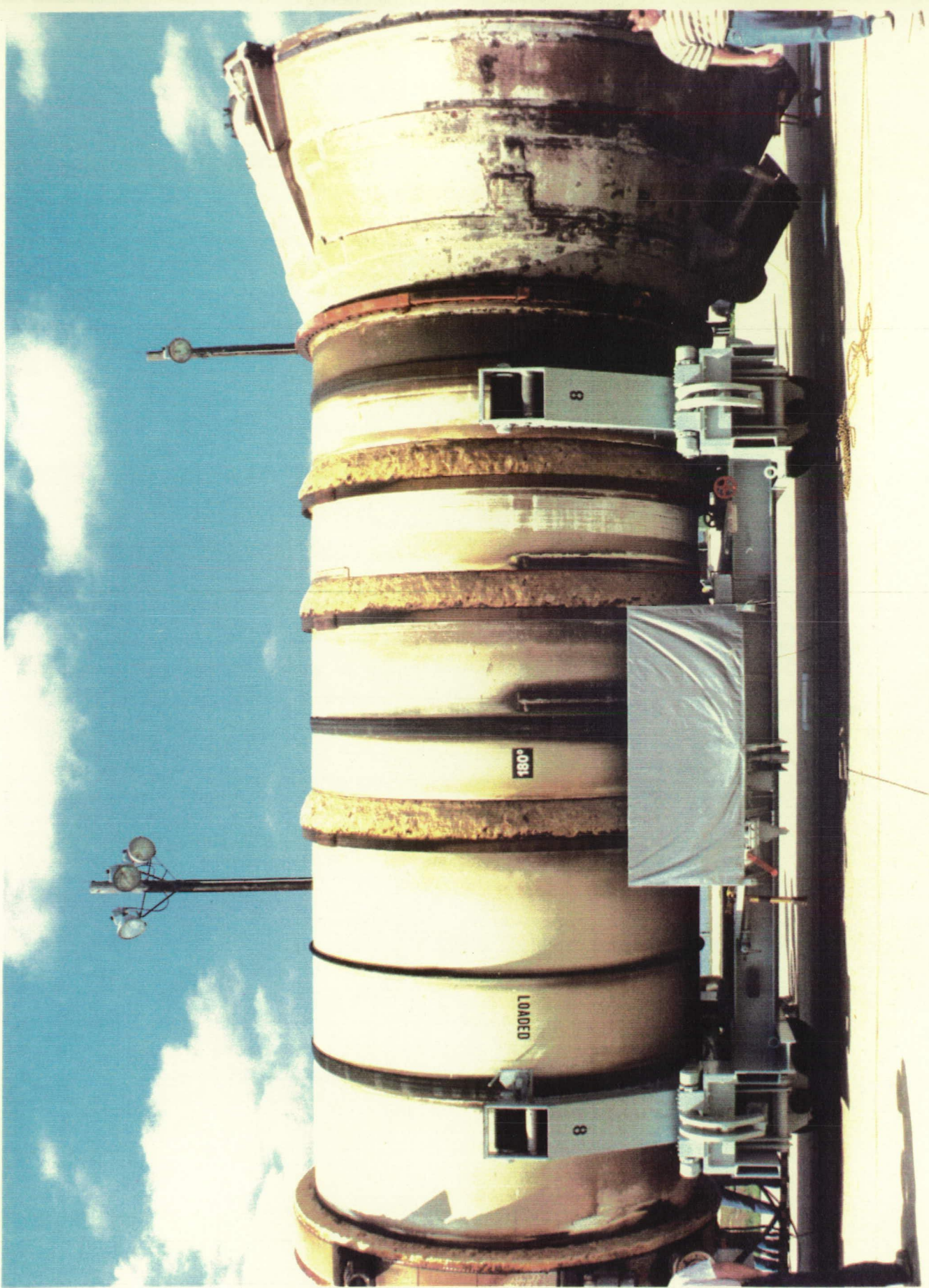

Post launch condition of the LH aft booster

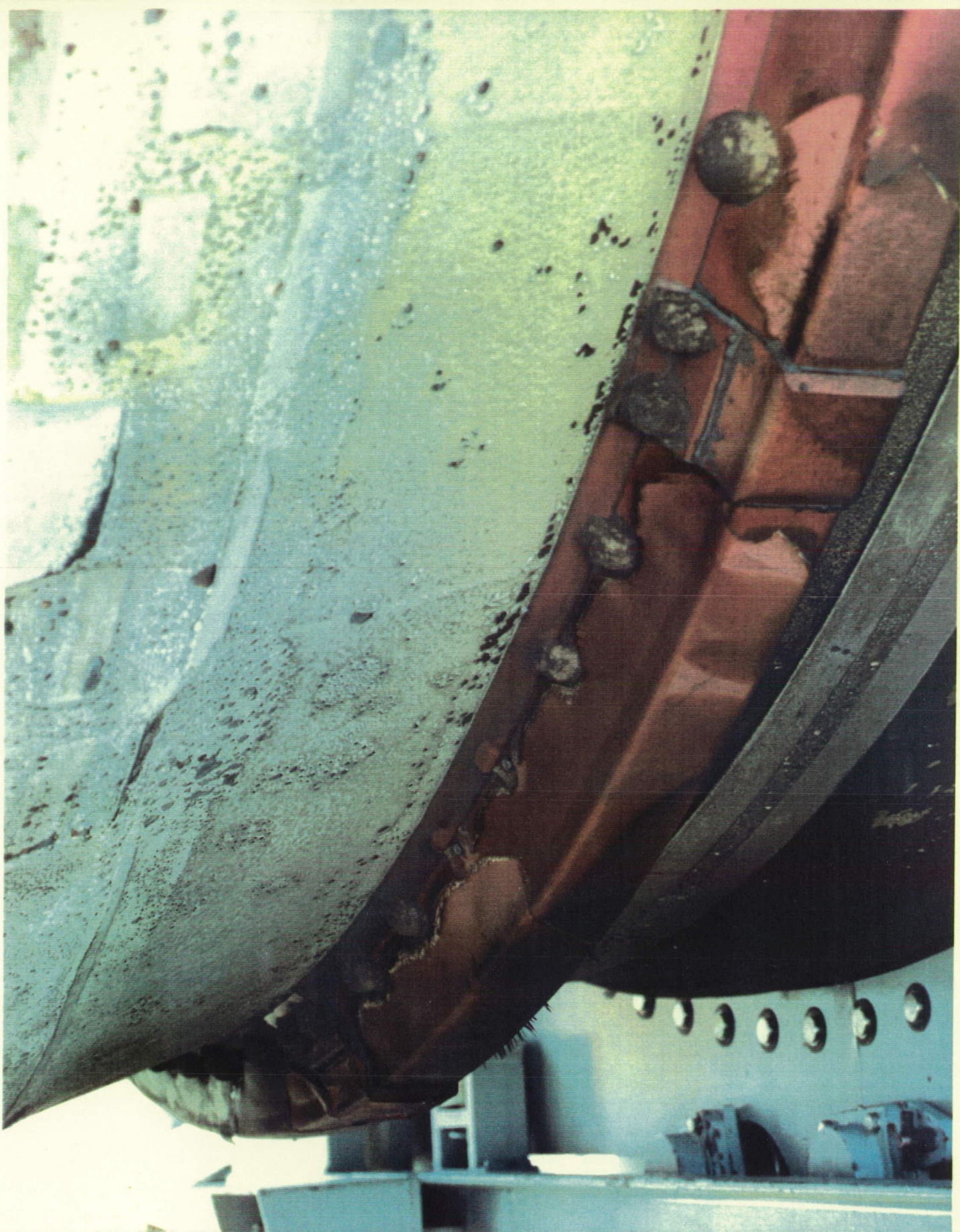

Phenolic material on the kick ring delaminated at several locations. K5NA protective domes were missing from boltheads.

## 9.0 ORBITER POST LANDING DEBRIS ASSESSMENT

A detailed post landing inspection of OV-103 (Discovery) was conducted April 29 and 30, 1990, at Ames-Dryden Flight Research Facility (Edwards Air Force Base) on Runway 22 and in the Mate/Demate Device (MDD) to identify debris impact damage, and if possible, debris sources. The Orbiter TPS sustained a total of 63 hits, of which 14 had a major dimension of one inch or greater. This total does not include the approximately 150 hits on the base heat shield.

The Orbiter lower surface had a total of 47 hits of which 13 had a major dimension of one inch or greater. A comparison of these numbers to statistics from 21 previous missions of similar configuration (excluding missions STS-24, 25, 26, 26R, 27R, and 30 which had damage from known debris sources), indicates the total number of hits on the lower surface less than average. Figures 17 - 20 show the TPS debris damage assessment for STS-31R.

The Orbiter lower surface tile damage sites were distributed approximately equally about the vehicle centerline. Only one of the sites observed was outboard of the main landing gear. A total of 8 hits occurred on the body flap lower surface. Two of these hits showed signs of significant thermal erosion (1/2 inch and 1 inch depths).

Damage to the base heat shield tiles was average (approximately 150 hits). The main engine closeout blankets had minor damage. The outer fabric on SSME #2 was peeled back for approximately 1 foot at 3 o'clock and a 1 foot section of the outer fabric layer was missing at 4 o'clock. SSME #3 had minor fraying of the outer layer for approximately 1 foot at 9 o'clock.

Several small pieces of gap filler sleeving material were protruding on both the RH and LH OMS pods at the leading edges. No detectable damage to adjacent tiles resulted from these gap fillers. The overall condition of the OMS pods was better than usual.

The 2-1/2 X 1 inch tile coating loss on the RH rudder speed brake trailing edge observed during post-launch film analysis was confirmed.

A broken, loosely attached 3 X 3 inch tile corner was observed in the Y star tracker cavity.

A 4 X 1/2 inch outer layer of AFRSI was peeled back forward of window #2.

Two pieces of material were removed from the LH2 ET/Orbiter umbilical area shortly after landing. They were submitted to the KSC Microchemical Analysis Lab.

FIGURE 17. DEBRIS DAMAGE LOCATIONS

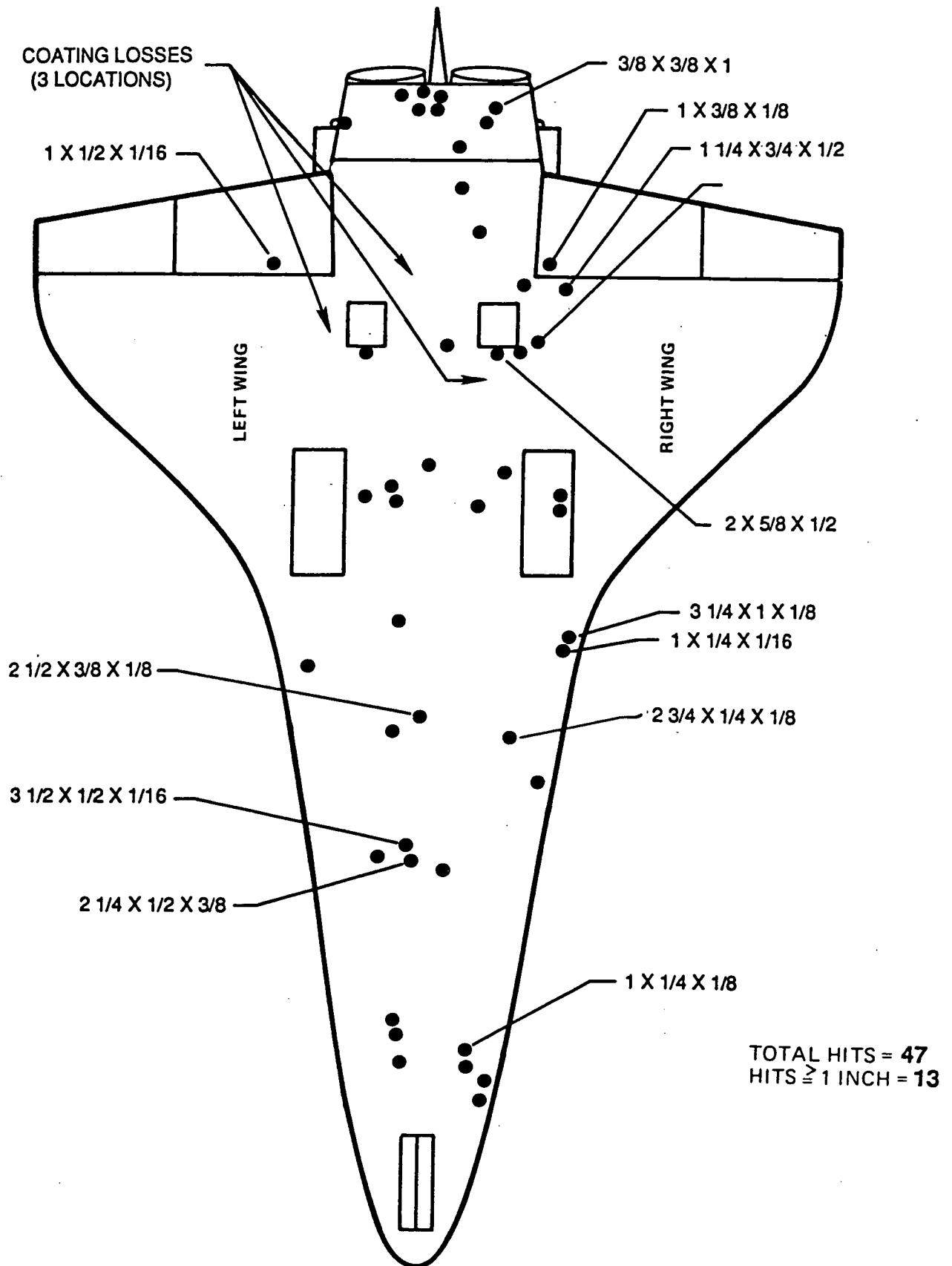
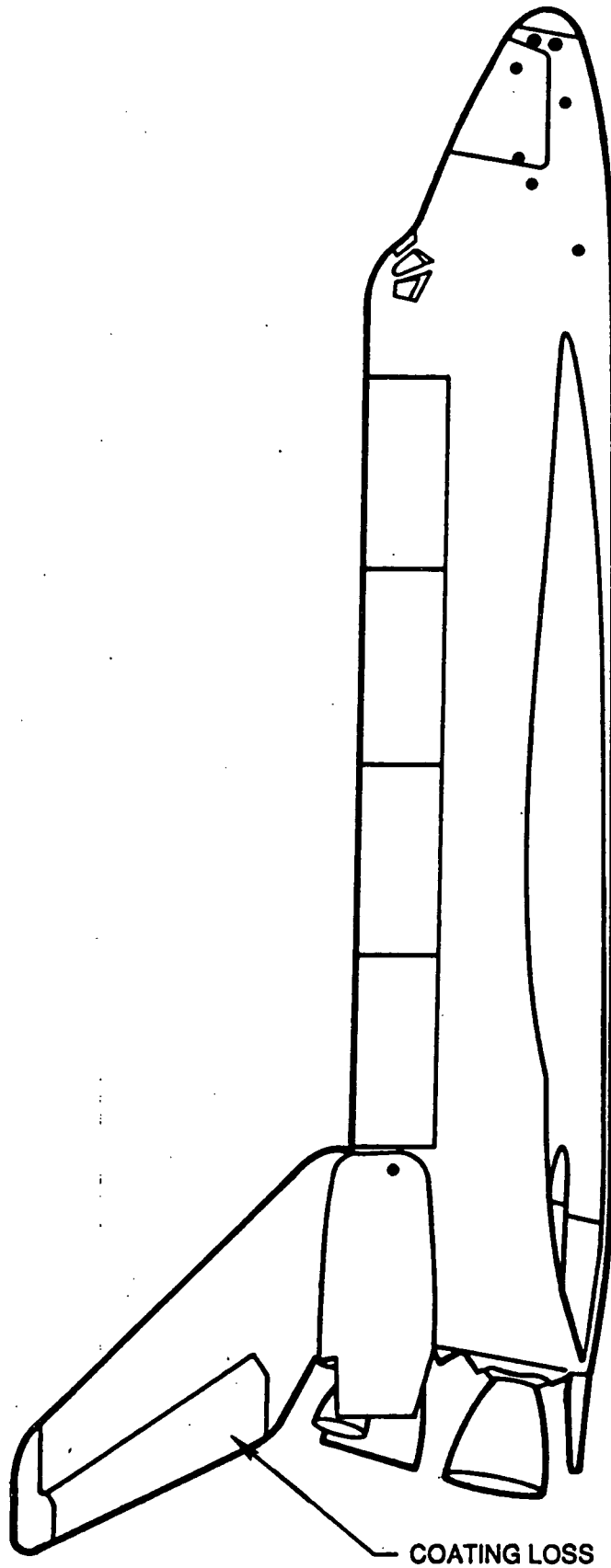

FIGURE 18. DEBRIS DAMAGE LOCATIONS



TOTAL HITS = 8  
HITS  $\geq$  1 INCH = 0

COATING LOSS

EGG/V-088A

FIGURE 19. DEBRIS DAMAGE LOCATIONS

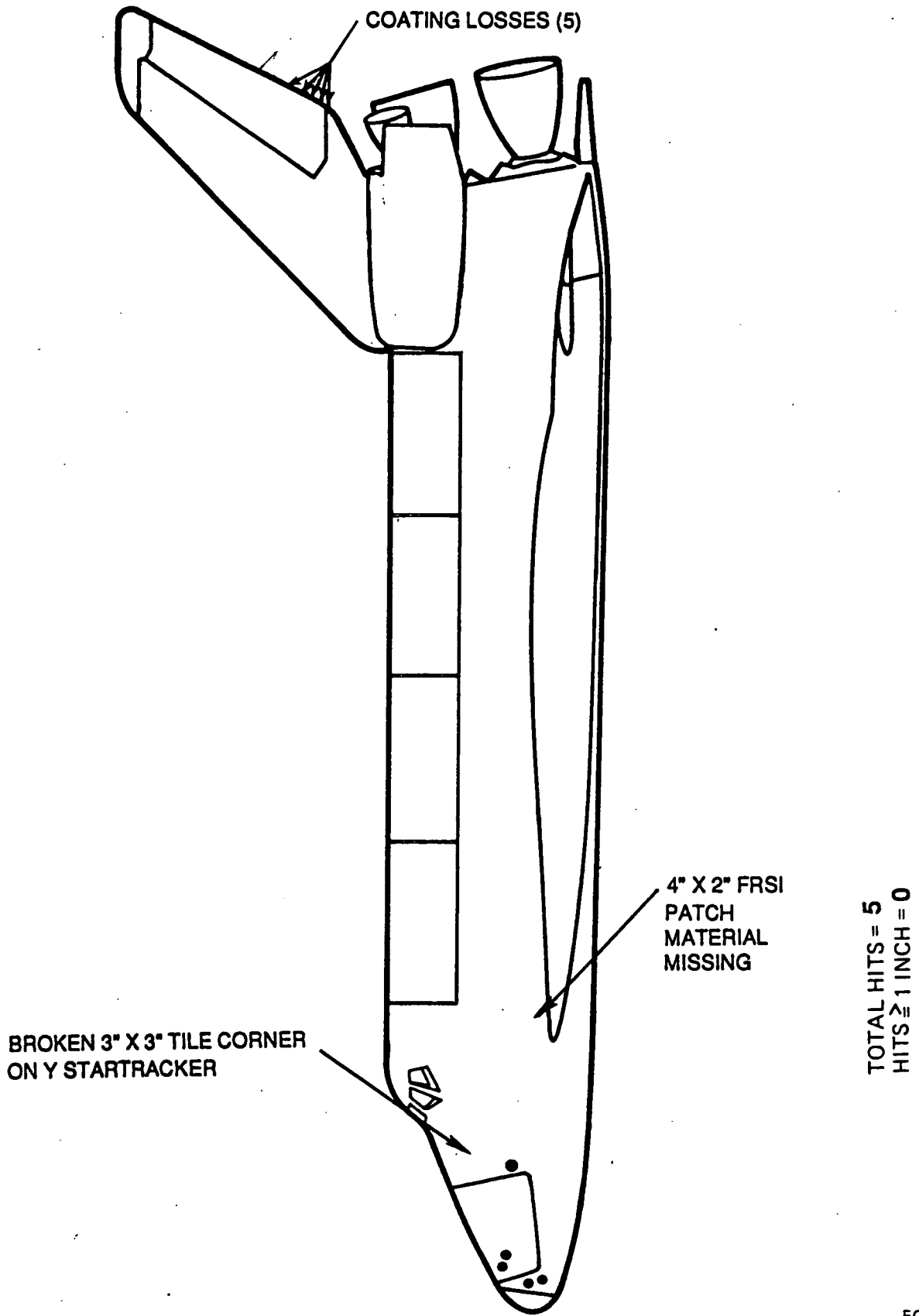
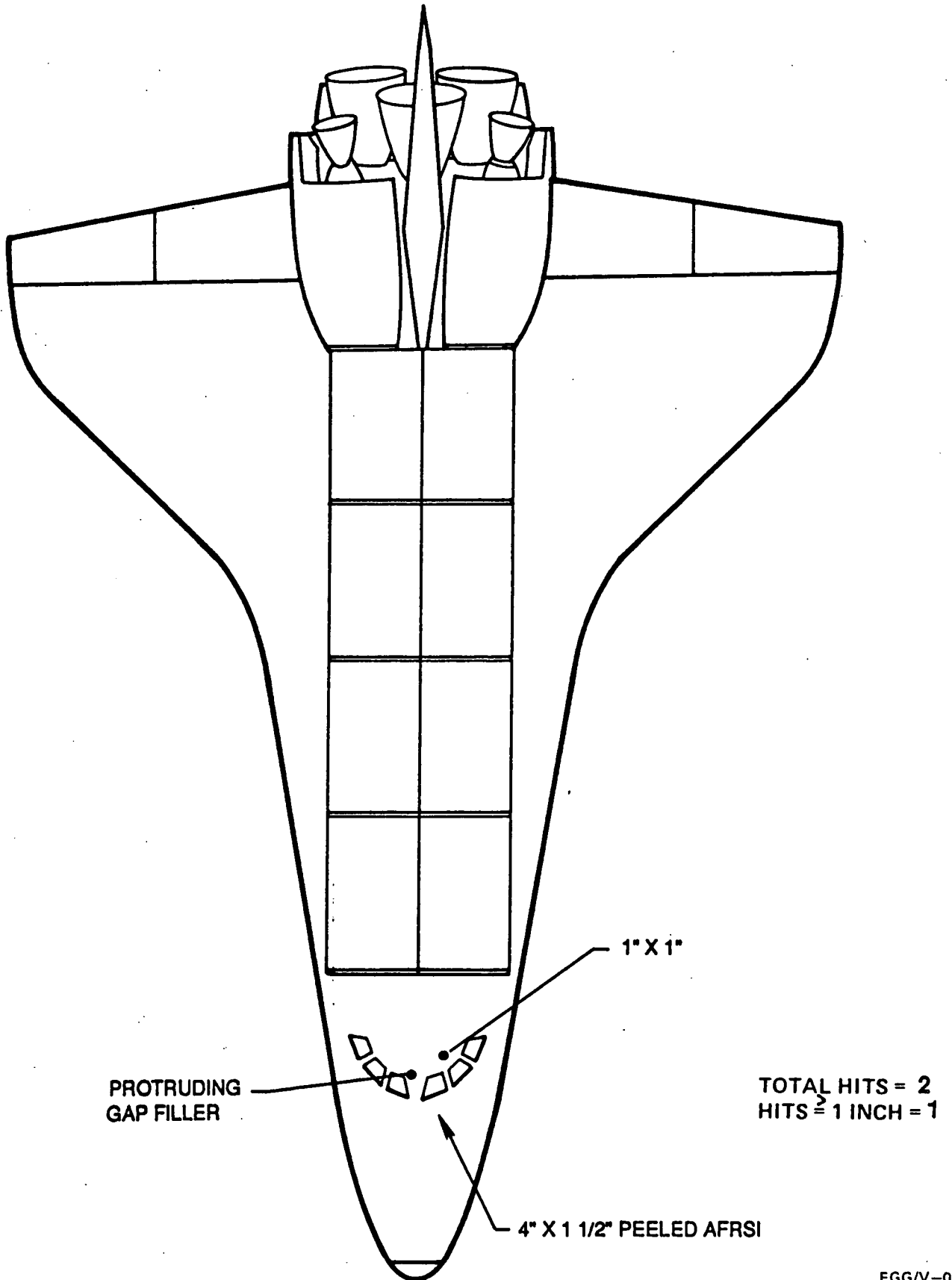



FIGURE 20. DEBRIS DAMAGE LOCATIONS



Once the Orbiter arrived in the MDD, samples were taken from selected damage sites (Figures 21 and 22) for laboratory analysis. The results of all debris sample chemical analyses are presented in Section 10.0.

All Orbiter windows had some hazing. Window #3 was heavily hazed with streaks. Window #4 was moderately hazed.

The separation ordinance devices appeared to have functioned properly. The plungers seated on EO-2 and EO-3 and the EO-1 bipod yoke bolt piston was flush with the outer mold line.

Orbiter tires, wheels, and brakes appeared to be in excellent condition and did not contribute to tile damage.

The KSC Shuttle Thermal Imager (STI) was used to record the kinetic surface temperatures of several areas (Figure 23). Nine minutes after landing the nose cap RCC measured 197 degrees F. Twelve minutes after landing the RH wing RCC panels #9 and #17 both measured 84 degrees F.

Runways 17L and 23L were inspected by the Debris Team on April 28, 1990. Runway 22 was inspected and cleaned by Air Force personnel on April 28, 1990. The general condition of the runway was good with very little debris found.

The post landing inspection of Runway 22 was performed at approximately L + 1/2 hour. One flat-head screw (1/4 inch dia., 5/16 inch grip, possible titanium) was found near the runway threshold. Legible markings on the head include 1580, V4, and -5. The screw will be submitted for laboratory analysis. Also, a strand of SSME closeout blanket material about 8 inches long was found approximately 2500 feet from the point of wheel stop.

In summary, the total number of lower surface Orbiter TPS debris hits was less than average when compared to previous flights as shown in the comparison chart (Figure 24-25). The distribution of hits on the Orbiter does not point to a single source for ascent debris, but indicates a shedding of ice and TPS debris from random sources.

Orbiter Post Landing Anomalies are listed in Section 11.4.

FIGURE 21. DEBRIS DAMAGE CHEMICAL SAMPLE LOCATIONS

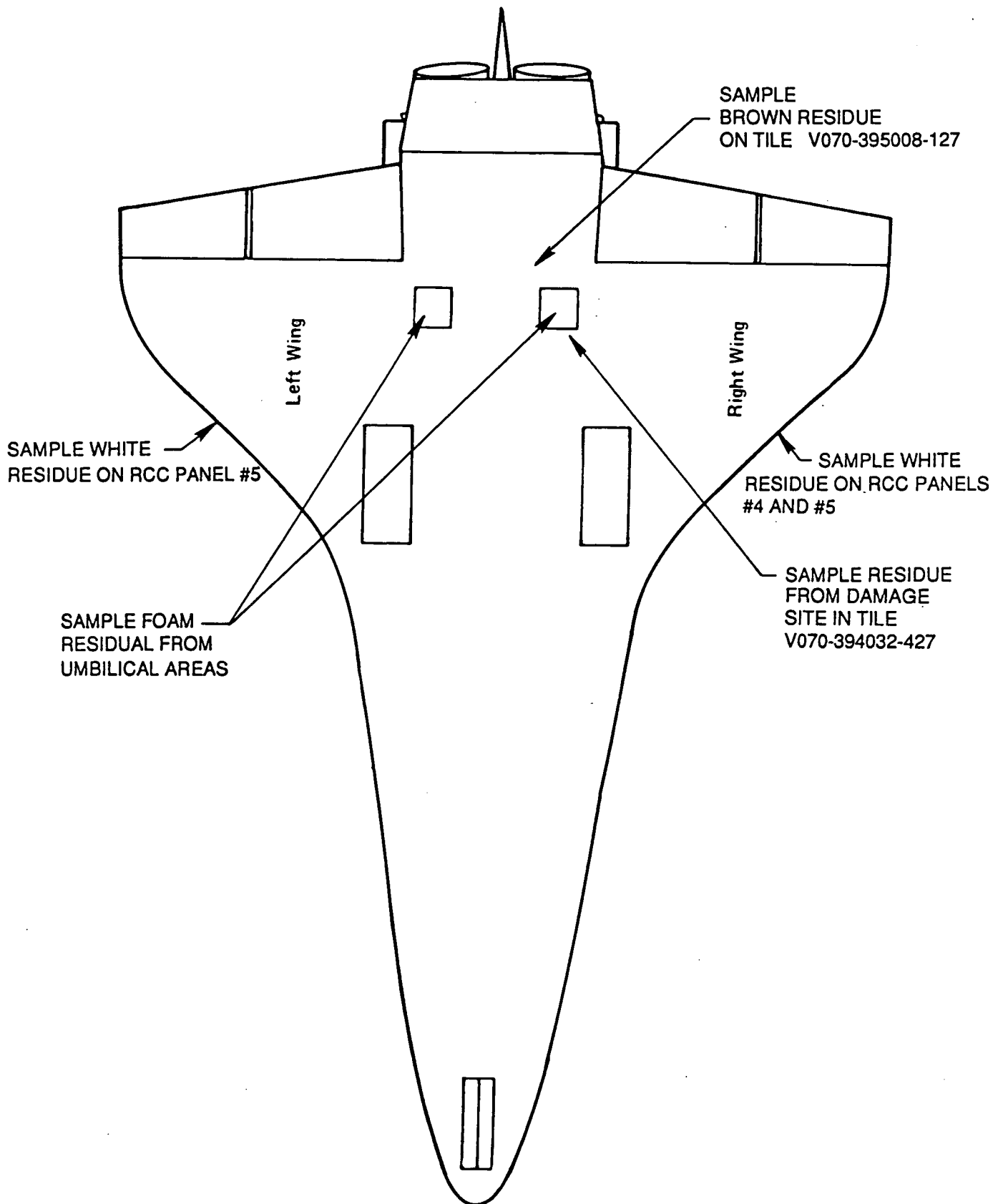

FIGURE 22. DEBRIS DAMAGE CHEMICAL SAMPLE LOCATIONS

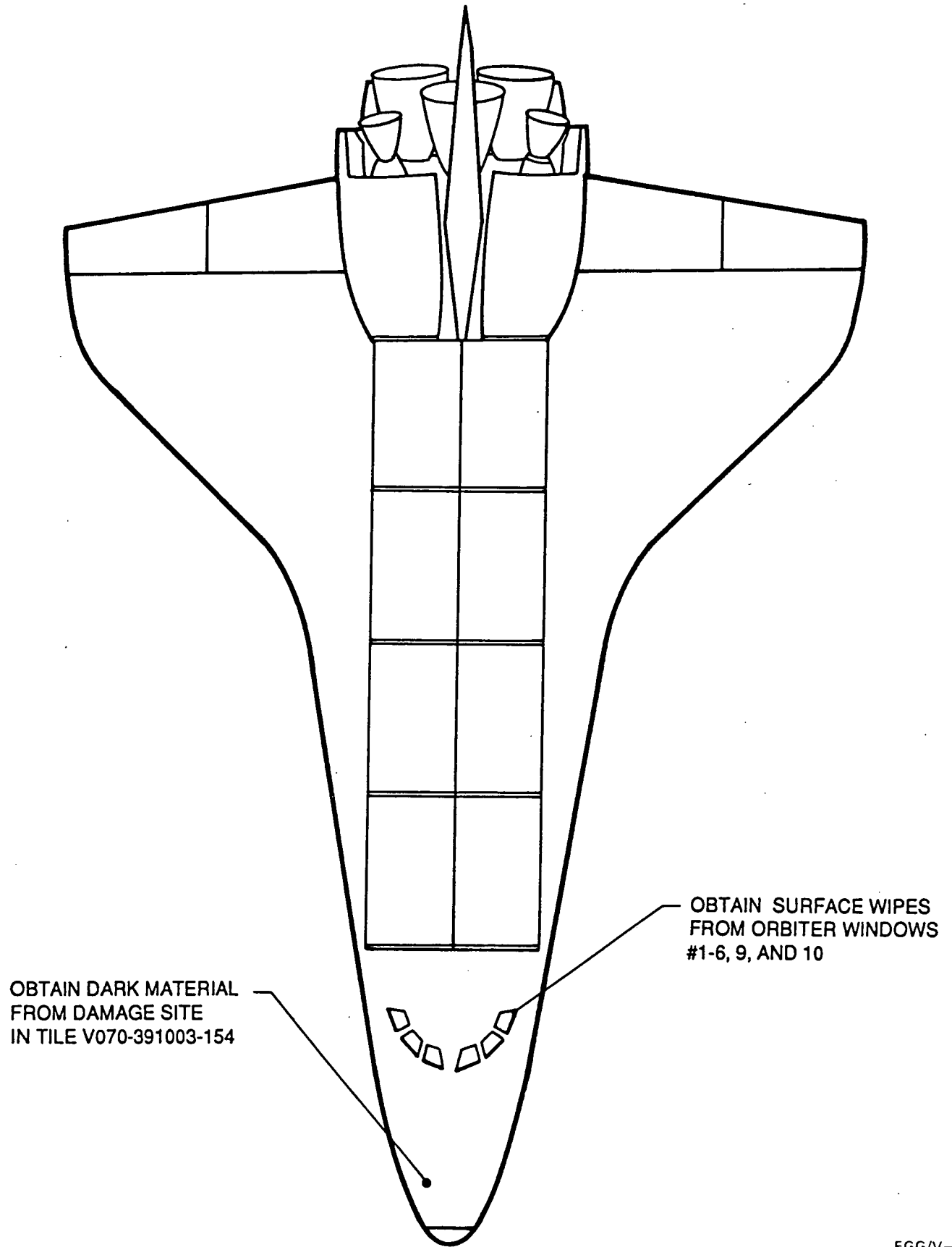

FIGURE 23. TEMPERATURE MEASUREMENTS

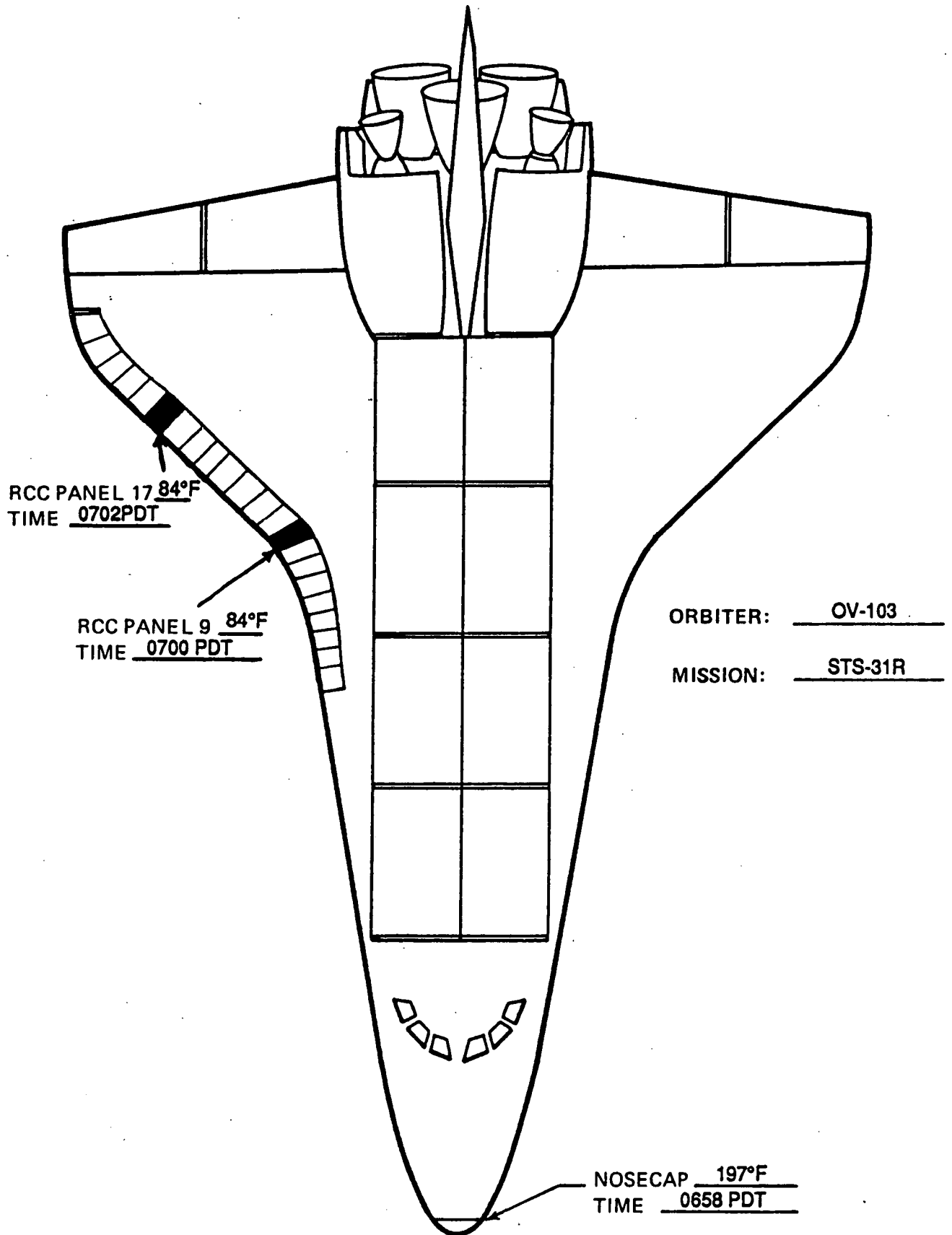

FIGURE 24. STS-31R DEBRIS DAMAGE ASSESSMENT SUMMARY

	<u>Hits &gt; or = 1"</u>	<u>Total Hits</u>
Lower Surface	13	47
Upper Surface	1	2
Right Side	0	7
Left Side	0	5
Right OMS Pod	0	1
Left OMS Pod	0	1
<b>TOTALS</b>	<b>14</b>	<b>63</b>

COMPARISON TABLE

STS-6	36	120
STS-7	48	253
STS-8	7	56
STS-9 (41-A)	14	58
STS-11 (41-B)	34	63
STS-13 (41-C)	8	36
STS-14 (41-D)	30	111
STS-17 (41-G)	36	154
STS-19 (51-A)	20	87
STS-20 (51-C)	28	81
STS-23 (51-D)	46	152
STS-24 (51-B)	63	140
STS-25 (51-G)	144	315
STS-26 (51-F)	226	553
STS-27 (51-I)	33	141
STS-28 (51-J)	17	111
STS-30 (61-A)	34	183
STS-31 (61-B)	55	257
STS-32 (61-C)	39	193
STS-26R	55	411
STS-27R	298	707
STS-29R	23	132
STS-30R	56	151
STS-28R	20	76
STS-34	18	53
STS-33R	21	118
STS-32R	15	120
STS-36	20	62
STS-31R	14	63

FIGURE 25. **COMPARISON TABLE**

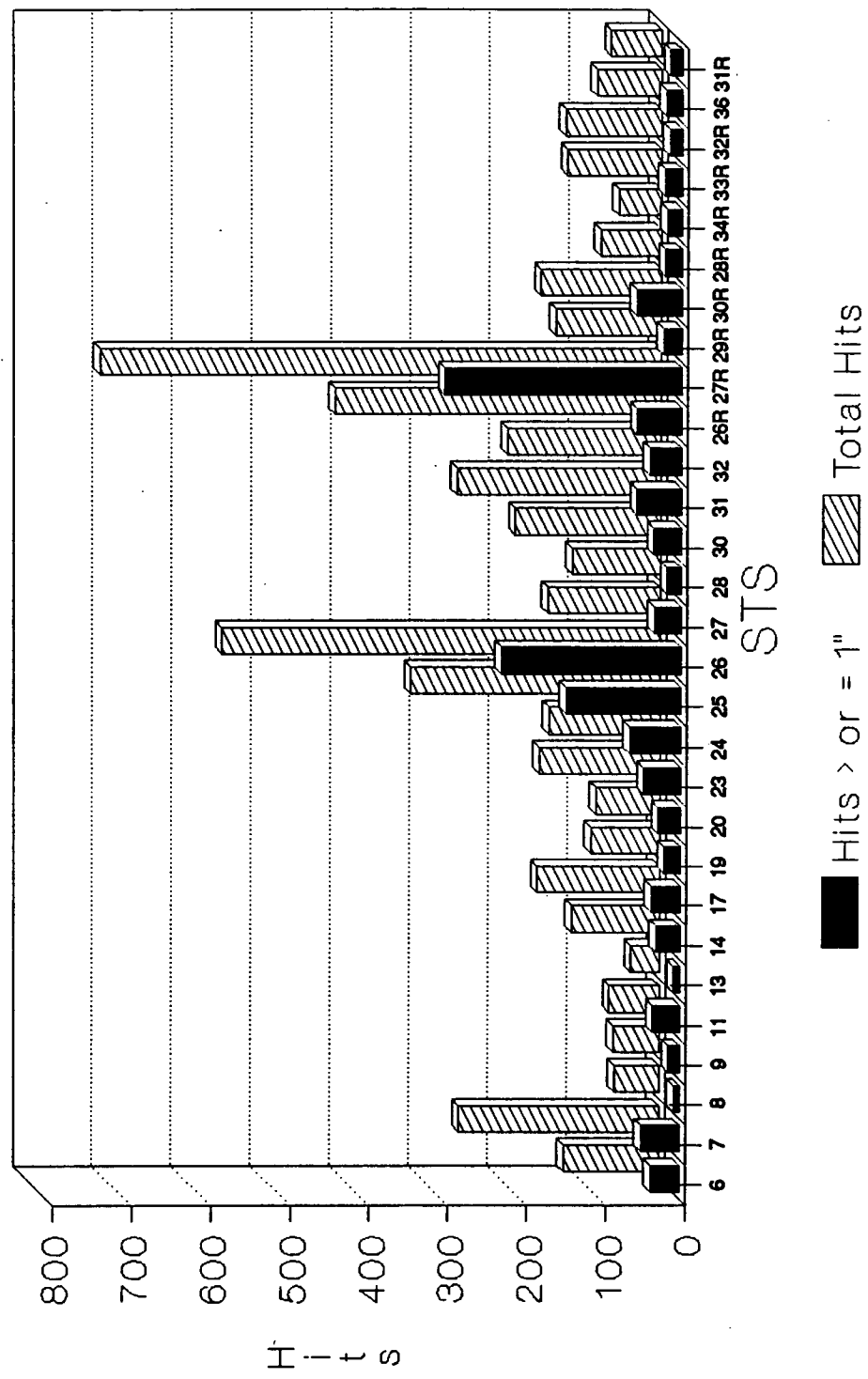



Overall view of OV-103 right side after landing





ORIGINAL PAGE  
COLOR PHOTOGRAPH

Overall view of OV-103 left side after landing

140

ORIGINAL PAGE IS  
OF POOR QUALITY



Overall view of Discovery nose and forward fuselage  
after landing

141

ORIGINAL PAGE  
COLOR PHOTOGRAPH



A 1-foot section of SSME #2 closeout blanket was peeled back and an adjacent 1-foot section (top layer) was missing



A 3"x3" tile corner was broken and loosely attached in the Y star tracker cavity

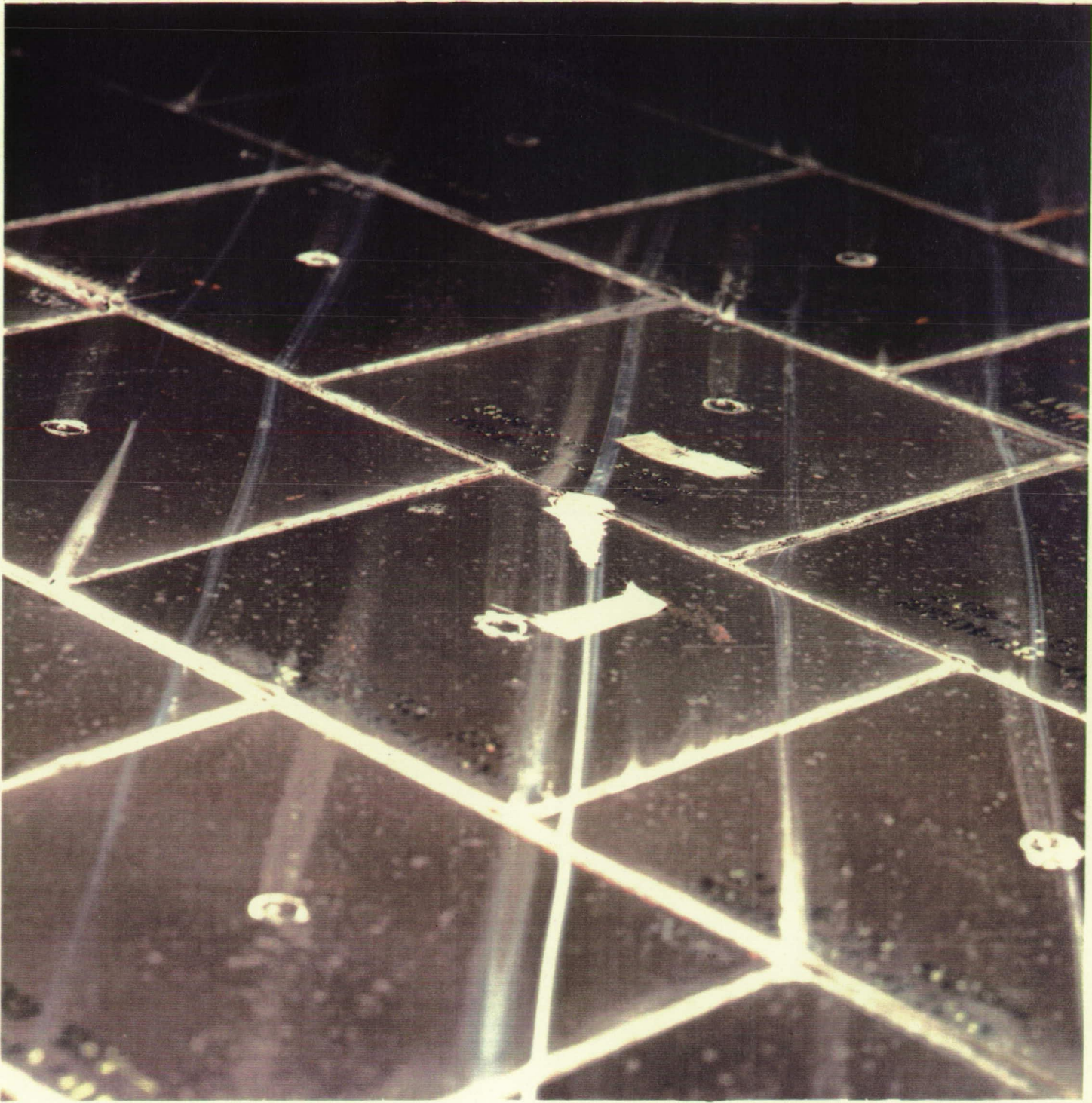

Typical debris impact damage to lower surface tile

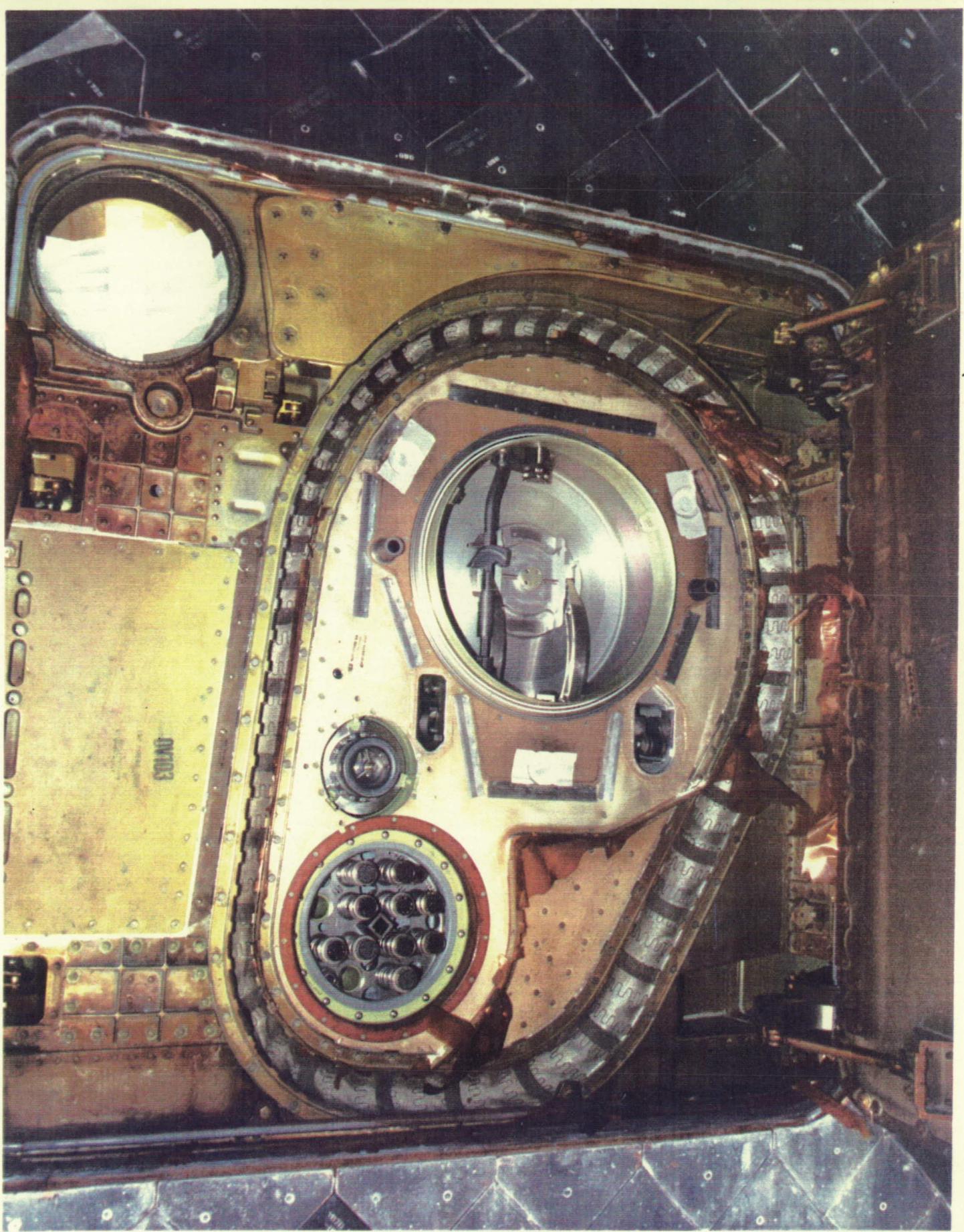

Post flight condition of the LO2 ET/ORB umbilical  
145

ORIGINAL PAGE  
COLOR PHOTOGRAPH

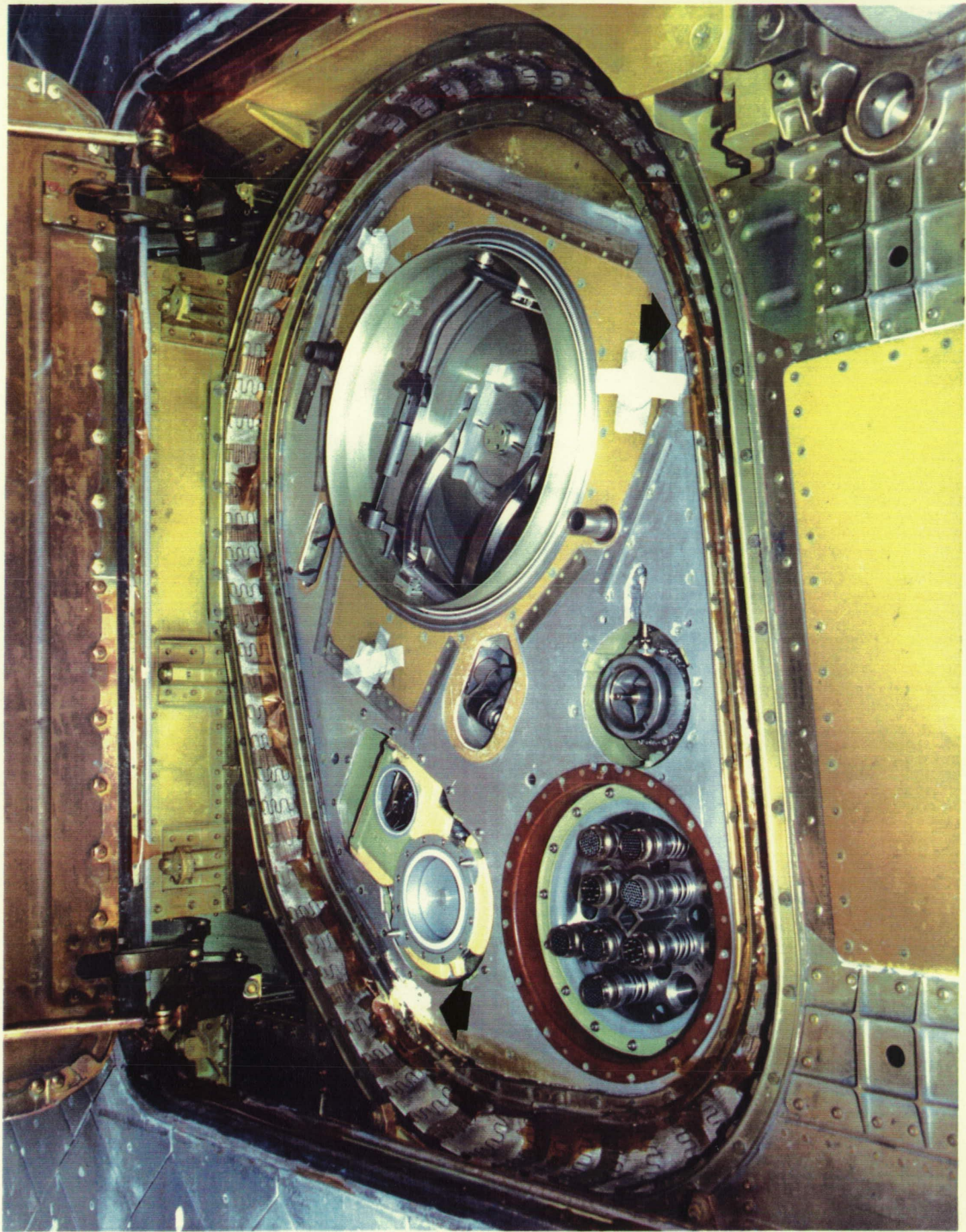

Post flight condition of the LH2 ET/ORB umbilical. Note closeout foam intrusion along interface (arrows)

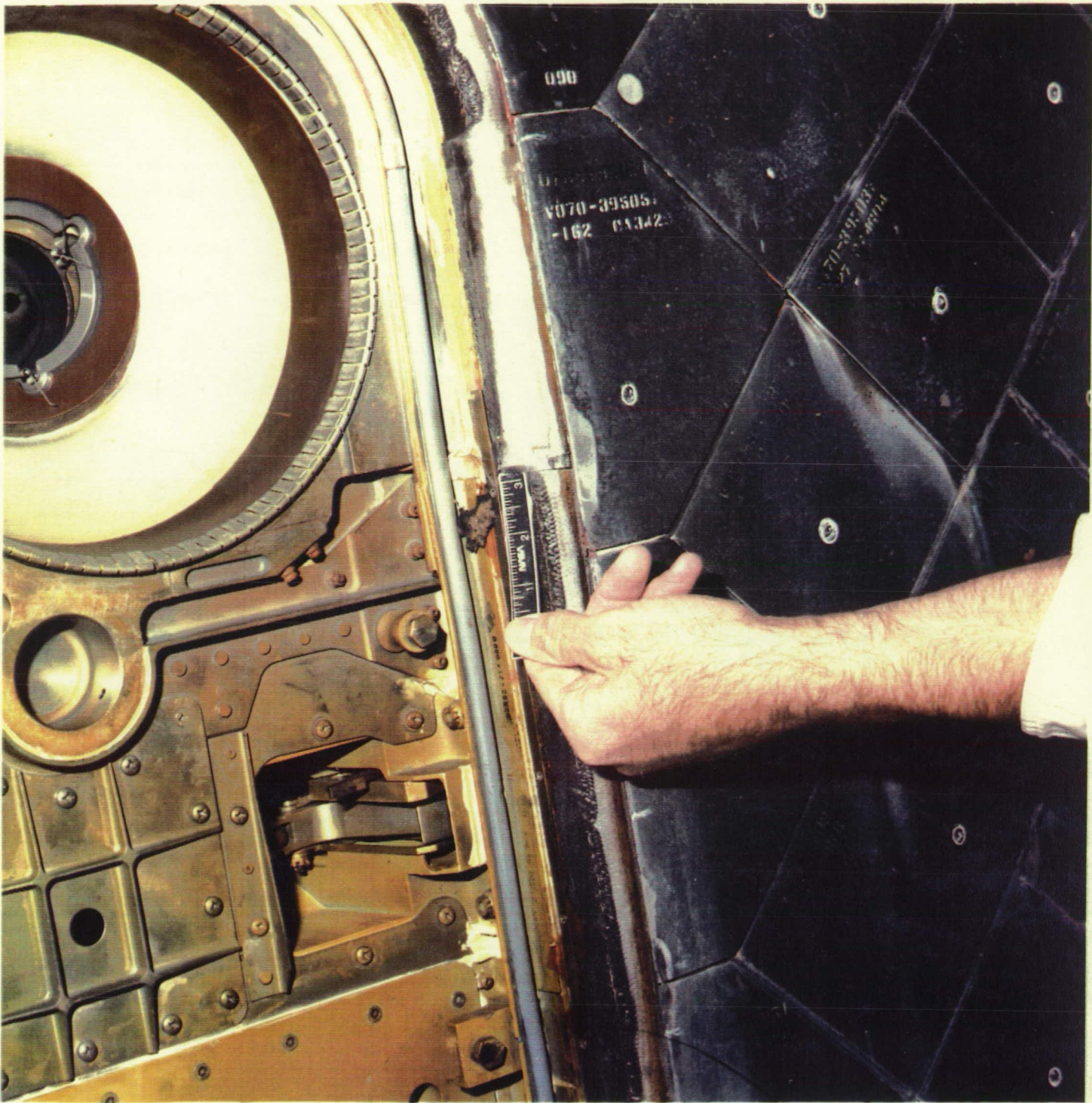

Brown/black-colored foreign material was removed from the LH2  
ET/ORB umbilical for laboratory analysis



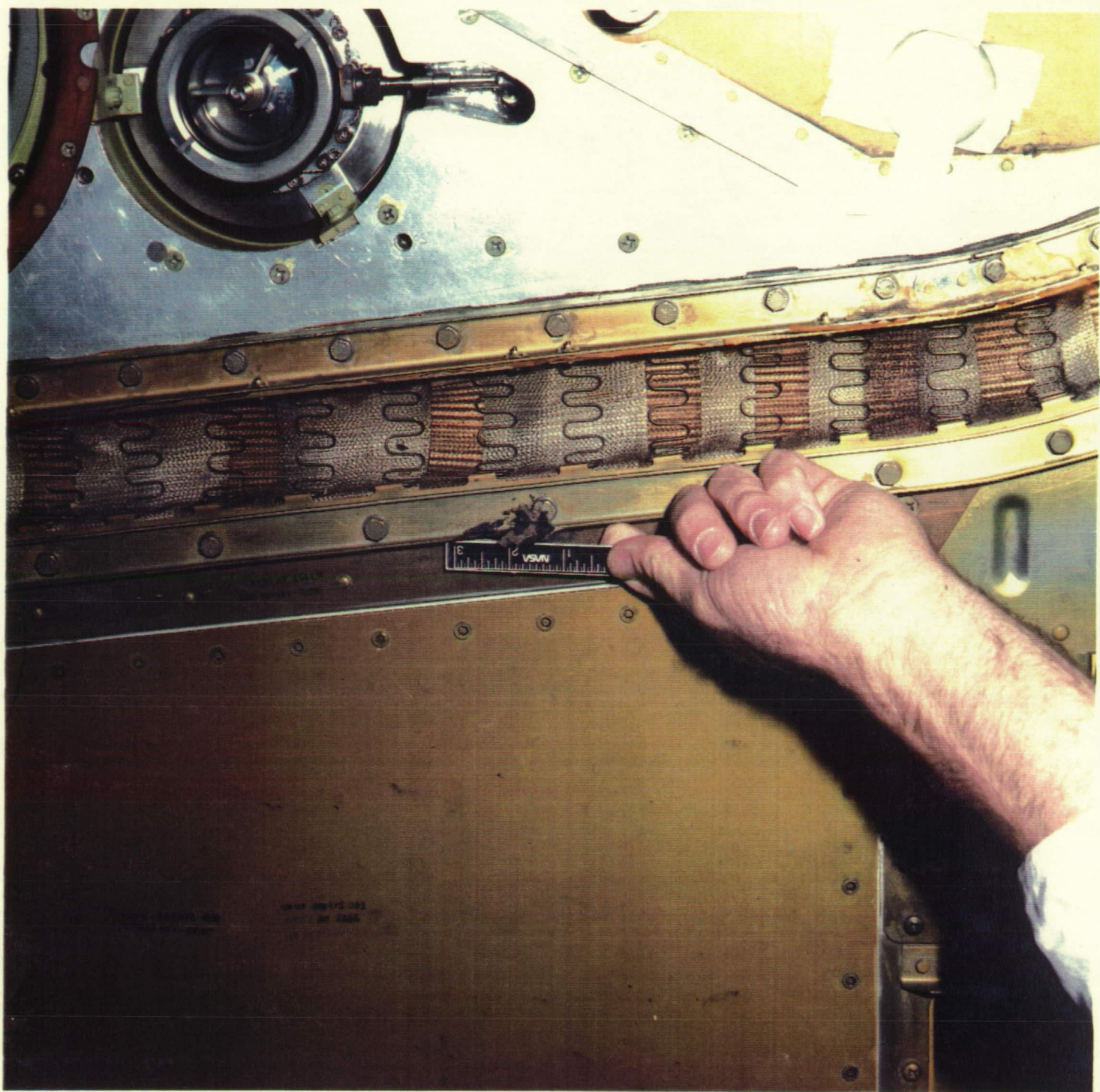

ORIGINAL PAGE  
COLOR PHOTOGRAPH

Brown/black-colored material removed from the LH2 umbilical  
was closeout materials (foam and Viton rubber seal)

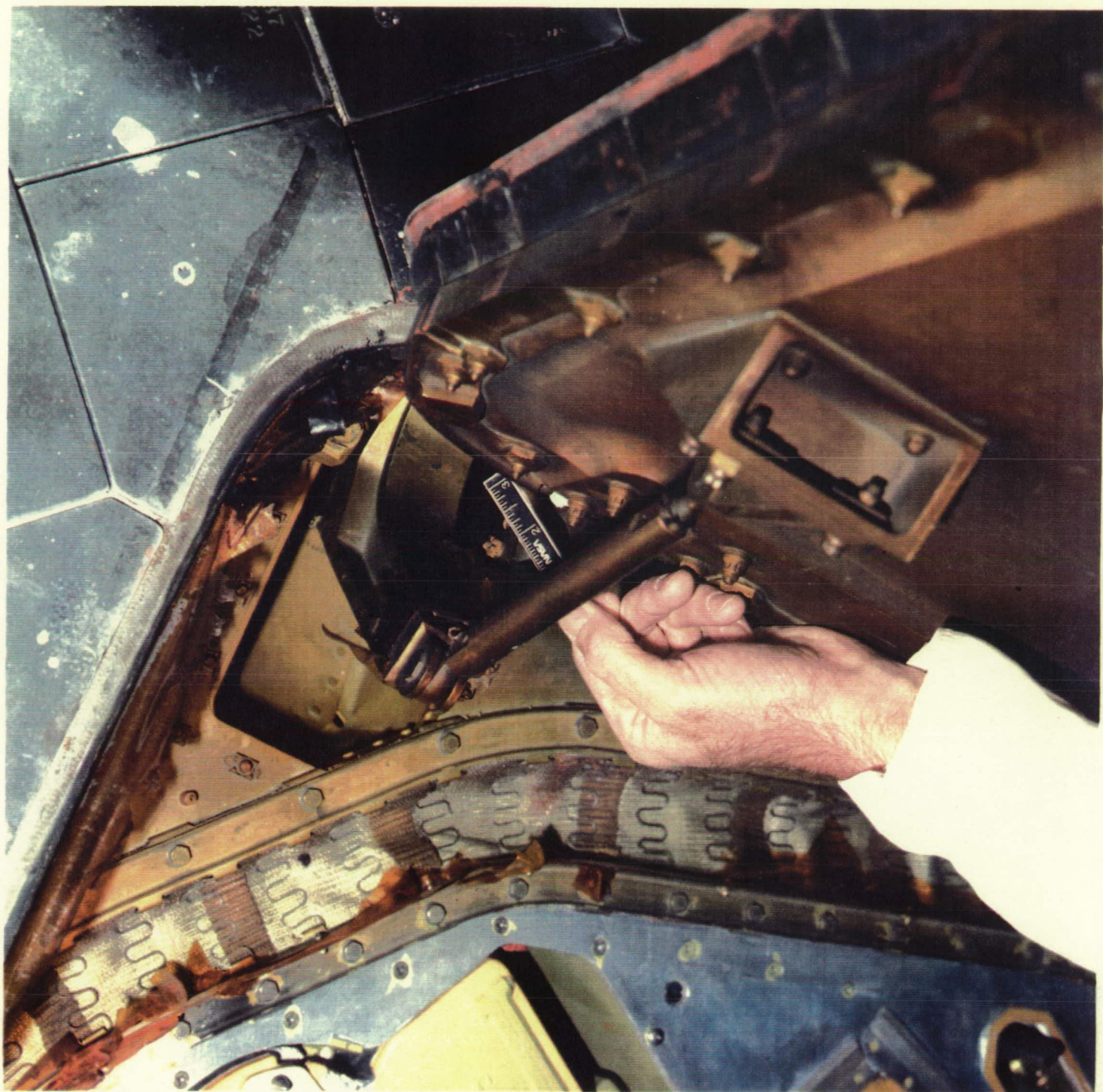

ORIGINAL PAGE  
COLOR PHOTOGRAPH

Analysis of light colored particle in the LH2 ET/ORB  
umbilical revealed TPS closeout material

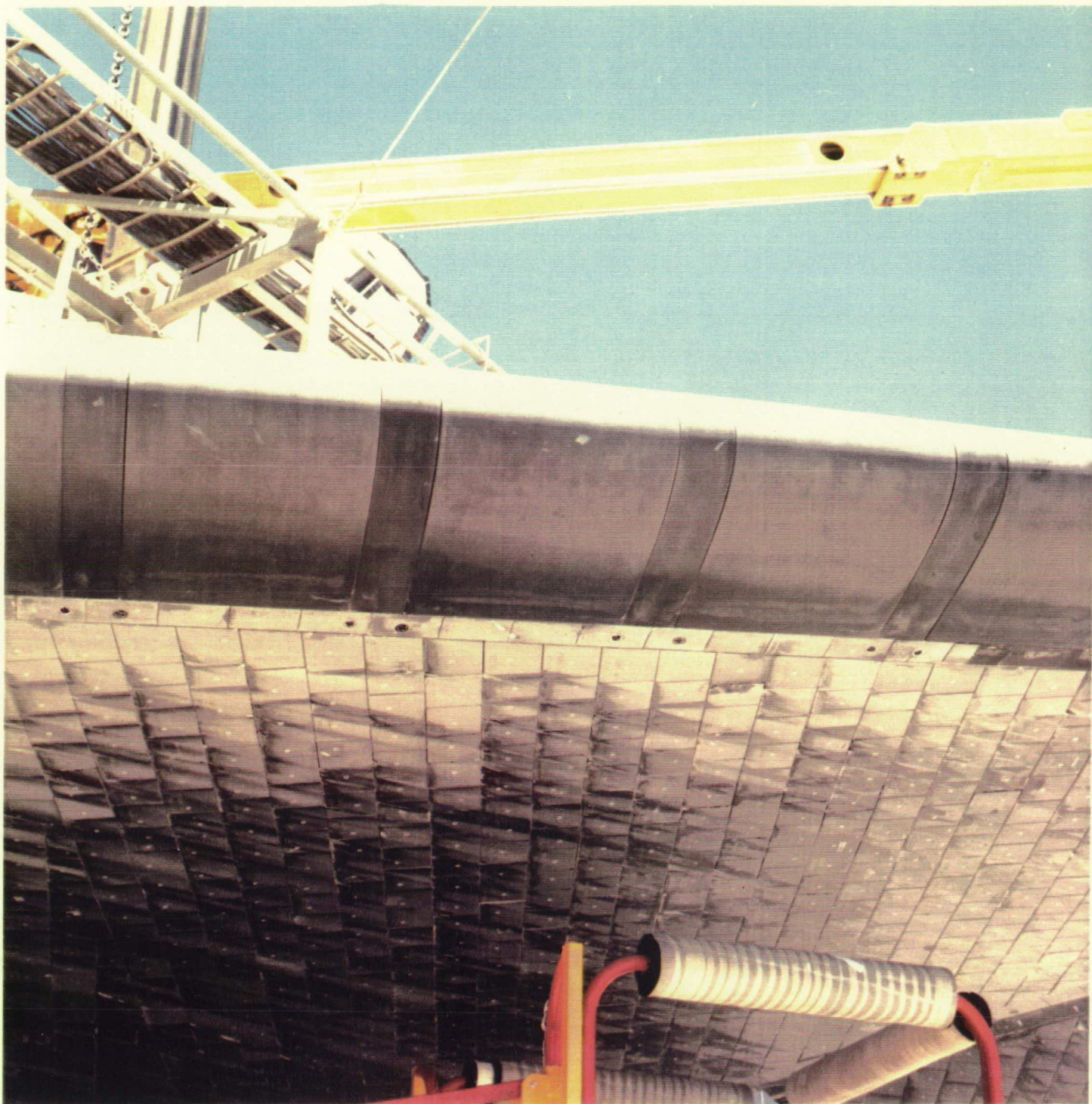

White residue on wing leading edge RCC panels was paint, TPS materials, BSM exhaust residue, and landing site products



Analysis of brown residue on lower surface tiles aft of RH MLG  
revealed paint, TPS materials, and landing site products



Analysis of dark residue in tile damage site cavity  
revealed tile material and landing site products  
152

ORIGINAL PAGE  
COLOR PHOTOGRAPH

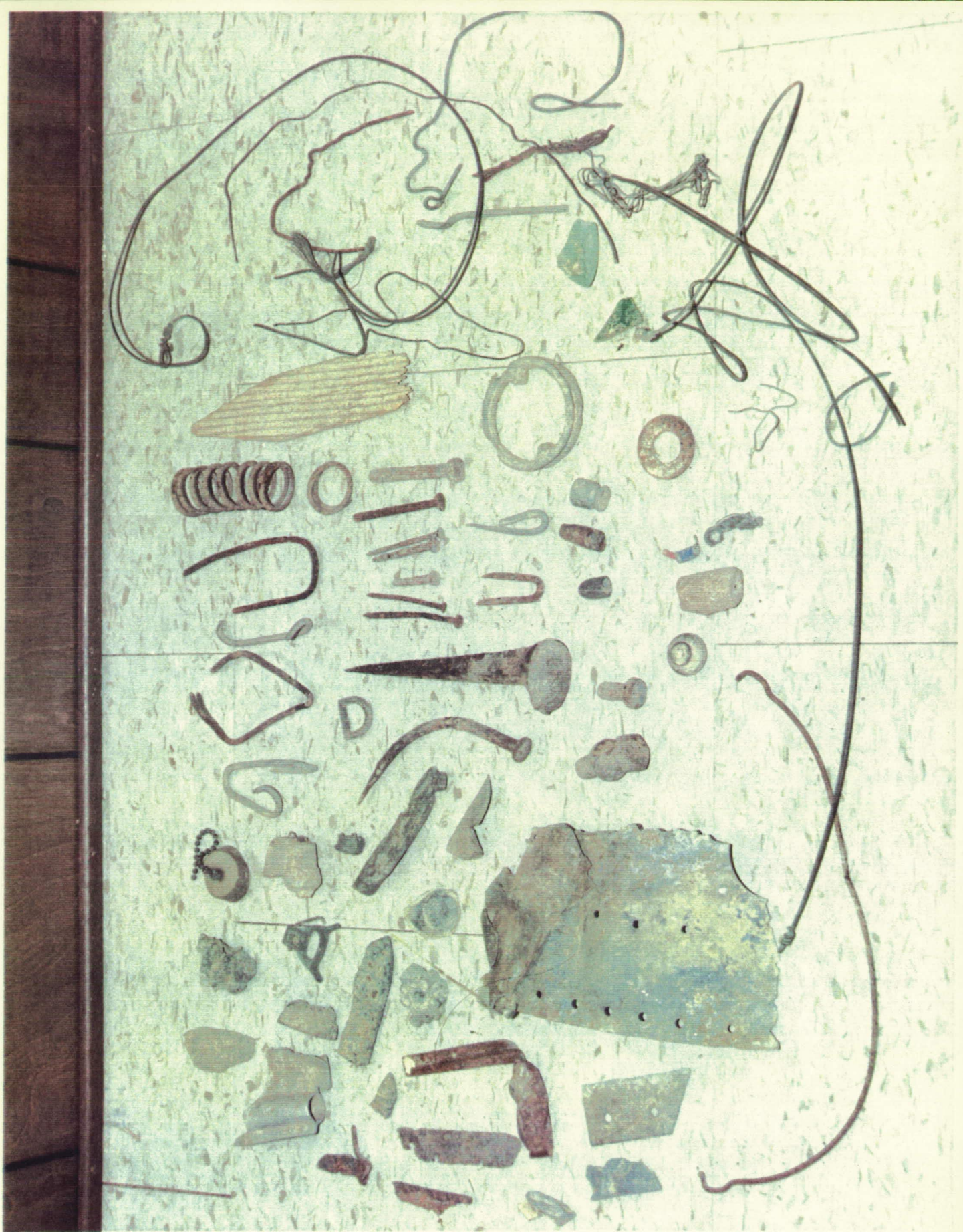

Debris collected during pre-landing runway walkdown

## 10.0 DEBRIS SAMPLE LAB REPORTS

A total of 19 samples were obtained from Orbiter OV-103 during the STS-31R post-landing debris assessment at Ames-Dryden Flight Research Facility, California (Figure 21-22). The 19 submitted samples consisted of 8 Orbiter window wipes, 3 tile samples, 2 wing leading edge RCC wipes, 5 samples from the ET/ORB umbilical area, and a fastener recovered from the runway surface. The samples were analyzed by the NASA KSC Microchemical Analysis Branch (MAB) for material composition and comparison to known STS materials. The specific elemental analysis is shown in the appended MAB reports. Debris analysis involves the placing and correlating of particles with respect to composition, availability and thermal (mission) effects. Debris samples and analyses are provided by Orbiter location in the following summaries.

### Orbiter Windows

Results of window wipe chemical analysis indicates the presence of the following materials:

1. Aluminum metal
2. Rust, dust and salt
3. Muscovite, calcite, plagioclase, hematite
4. Tile and insulation glass fibers
5. Organics
6. Alpha-Quartz

Debris analysis provides the following correlations:

1. Aluminum metal is common to the landing site and SRB/BSM exhaust but are not considered a debris concern in this quantity (micrometer).
2. Rust is probably an SRB BSM residue; dust and salt are landing site products.
3. Muscovite, calcite, plagioclase, and hematite are naturally-occurring landing site products.
4. Tile and insulation glass fibers originate from Orbiter thermal protection system (TPS).
5. Organic materials are probably insect/animal remains and deposits, or tile waterproofing.
6. Alpha-Quartz is one of the purest forms of the earth mineral silica and tile base component.

## **Orbiter Tile**

Results of the tile sample chemical analysis revealed the presence of the following materials:

1. Paint
2. Insulation glass
3. RTV
4. Black and White tile fibers
5. Muscovite

Debris analysis provides the following correlations:

1. Paint is used as flight element and facility/ground support equipment coating.
2. Insulation glass is used on Orbiter thermal protection system (TPS).
3. RTV is extensively used in Orbiter thermal protection system (TPS).
4. Black and white tile fibers originate from Orbiter thermal protection system (TPS).
5. Muscovite is a naturally-occurring landing site product.

## **Orbiter wing RCC panels**

Results of the wing leading RCC samples indicated the presence of the following materials:

1. Aluminum and steel particles
2. Black and white tile
3. Dust and rust
4. Primer and paint
5. Muscovite
6. Insulation glass
7. Polyurethane foam
8. Organics

Debris analysis provides the following correlations:

1. Aluminum and steel particles are probably SRB/BSM exhaust residue.
2. Black and white tile originate from Orbiter thermal protection system (TPS).
3. Dust is of naturally-occurring environmental origin, rust is probably SRB/BSM residue.
4. Primer and paint are used as flight element and facility/ground support equipment coatings.
5. Muscovite is a naturally-occurring landing site product.
6. Insulation glass is from Orbiter thermal protection system (TPS).
7. Polyurethane foam is used on both ET and SRB thermal protection system (TPS).



8. Organics as found are probably contaminants from sampling technique/handling - nylon/polyamide from a film or bag, PVC from a tile shim (scraper), polyethylene/cellulose acetate from sample containment materials.

#### **ET-Orbiter umbilicals**

Chemical analysis of samples from the ET/Orbiter umbilicals revealed the following materials:

1. Polyamide
2. Fluorocarbon
3. Polyurethane foam

Debris analysis provides the following correlations:

1. Polyamide particles probably originated from the sampling technique, such as a film or bag.
2. Fluorocarbon is probably Viton rubber from umbilical seals.
3. Polyurethane foam is used as a closeout material for the umbilicals.

#### **Fastener from runway**

Chemical analysis revealed the fastener found on the runway was titanium-aluminum with a green primer coating. It is not related to those types used on STS hardware.

#### **Conclusions**

The STS-31R mission, as evidenced by the debris analysis report, was successful in minimizing damage from debris. This is also shown to be true by the chemical analysis that was performed on post-flight samples.

The Orbiter window sampling provided results that indicate exposure to SRB/BSM exhaust residue, thermal protection system materials, and landing site products.

The Orbiter tile sampling revealed paint, thermal protection system, and landing site material exposure. Damage site samples provided indication of Orbiter thermal protection system (TPS) and landing site (trace) materials only.

The Orbiter wing RCC sampling indicated paint products, thermal protection system materials, SRB/BSM exhaust residue, and landing site products.

Samples from the ET/Orbiter umbilical area indicated only closeout materials.

This mission provided no evidence of orbital debris impacts.

MICROCHEMICAL ANALYSIS BRANCH  
DM-MSL-1, ROOM 1274, O&C BUILDING  
NASA/KSC  
MAY 14, 1990

SUBJECT: Debris Samples From STS-31R Landing At DFRF/EAFB

LABORATORY REQUEST NO: MCB-0362-90

RELATED DOCUMENTATION: Intercenter Debris Team Requirements

1.0 FOREWORD:

1.1 REQUESTER: R. F. Speece/TV-MSD-22/7-0806

1.2 REQUESTER'S SAMPLE DESCRIPTION: The samples were from OV-103, STS-31R landing at DFRF/EAFB, and were identified as follows:

- #1. Alcohol swabs from Orbiter window #1.
- #2. Alcohol swabs from Orbiter window #2.
- #3. Alcohol swabs from Orbiter window #3.
- #4. Alcohol swabs from Orbiter window #4.
- #5. Alcohol swabs from Orbiter window #5.
- #6. Alcohol swabs from Orbiter window #6.
- #7. Alcohol swabs from Orbiter window #~~7~~.<sup>9</sup>
- #8. Alcohol swabs from Orbiter window #~~8~~.<sup>10</sup>
- #9. Material removed from LH2 ET/Orbiter umbilical outboard seal area.
- #10. Material removed from LH2 ET/Orbiter umbilical outboard plate surface.
- #11. Material removed from LH2 ET/Orbiter umbilical outboard plate surface.

1.3 REQUESTED: Identify composition of samples and compare to known STS materials.

2.0 CHEMICAL ANALYSIS AND RESULTS:

2.1 Procedure:

The submitted samples were analyzed by means of optical microscopy (OM), infrared spectrometry, and electron microprobe with energy dispersive spectrometry (EDS).

2.2 Results:

2.2.1 The particulates from each sample were classified into components on the basis of color and texture by OM. The classified components from all samples are listed in Table 1 with the possible identification of each component and elemental analysis.

Table 1

Component ID	Possible Ident.	Elemental Analysis by EDS*	
		Major	Minor
1. Metallics	Al-Particle	Al	
2. Lgt Brn Mtls	Dust, Rust	Al, Si, Ca, Fe	K, S, Zn, Ti, Cl, Mg
3. Lgt Grey Mtls	Si-Al rich	Si, Al	S, Cl, K, Ca, Fe
4. Black Mtls	Dust, Rust	Si, Al, Fe, Ca	S, K, Cl
5. Red Mtls	Rust	Fe, Si	Cl, K, Ca
6. Amber Flake	Muscovite	Fe, K, Si, Al	Mg, Ti
7. Glass Fiber	Tile, Insul.	Si, Ca	Al
8. Organics			
9. Organic Fiber	ND		
10. Foam			

\*: O, C, H, and B are not detectable by using this technique.

2.2.2 Table 2 lists estimated amounts of each component versus sample number.

Table 2

Sample No. Components	#1	#2	#3	#4	#5	#6	#7	#8	#9	#10	#11
1. Metallics	X	X	T	X	X	X	X	X	X	X	X
2. Lgt Brn Mtls	87	46	65	81	86	94	92	94	X	X	X
3. Lgt Grey Mtls	X	40	20	5	2	T	T	T	X	X	X
4. Black Mtls	2	5	4	3	3	1	1	2	X	X	X
5. Red Mtls	3	2	X	X	X	X	X	X	X	X	X
6. Muscovite	4	4	6	8	6	3	5	3	X	X	X
7. Glass Fiber	X	T	T	T	T	T	T	T	X	X	X
8. Organics	4	3	5	2	2	2	2	1	100	100	X
9. Organic Fiber	T	T	T	1	1	T	T	T	X	X	X
10. Foam	X	X	X	X	X	X	X	X	X	X	100
Particle Size, um	1-150	1-80	1-150	1-120	1-100	1-110	1-85	1-120	L	L	L

87: Estimated Volume Percent.

X: Not detected.

T: Trace.

L: Large Piece (20 or 30 mm in diameter).

### 3.0 CONCLUSIONS:

- 3.1 The sample number 3 contained trace amounts of Al-metals.
- 3.2 The sample number 1 through 8 contained appreciable amounts of light-brown materials. The EDS and polarized light microscopy data suggested that the light brown materials were composed of calcite ( $\text{CaCO}_3$ ), Alpha-Quartz (Alpha- $\text{SiO}_2$ ), plagioclase ( $\text{NaAlSi}_3\text{O}_8$ - $\text{CaAl}_2\text{Si}_2\text{O}_8$ ), hematite ( $\text{Fe}_2\text{O}_3$ ), opaque, clay minerals and pollens.
- 3.3 The sample numbers 2 through 8 contained light grey materials. The light grey materials appeared to be composed of cryptocrystalline Si-Al rich materials which might be the components of insulation materials.
- 3.4 The sample numbers 1 and 8 and 1 through 2 contained black and red materials, respectively. those materials appeared to be composed mainly of dust, rust, and some salt components.
- 3.5 The sample numbers 1 through 8 contained muscovite [ $\text{KAl}_2(\text{AlSi}_3\text{O}_{10})(\text{OH})_2$ ].
- 3.6 The sample numbers 2 through 8 contained trace amounts of glass fibers. The glass fibers were composed of either tile glass or insulation-type glass.
- 3.7 The sample numbers 1 through 10 contained organics. The organics from sample number 1 through 8 were not analyzed at this time due to small amounts of samples. The organics from sample numbers 9 and 10 were composed of polyamide (white materials) and fluorocarbon (black materials).
- 3.8 The sample numbers 1 through 8 contained organic fibers. The organic fibers were not analyzed at this time due to small amounts of sample.
- 3.9 The sample number 11 contained foam. the foam was identified to be ester-type polyurethane.
- 3.10 The particle sizes from the sample numbers 1 through 8 were estimated to be in the range of 1 to 150 micrometer. the particle sizes from the sample numbers 9 through 11 were estimated to be in the range of 20 to 30 millimeter.

3.11 The light-brown materials, red materials, black materials and muscovite appeared to be very similar in composition to these of lakebed soil [MCB1097-89] in California.

CHEMIST: H. S. Kim  
H. S. Kim

APPROVED: J. Jones  
J. Jones

MICROCHEMICAL ANALYSIS BRANCH  
DM-MSL-1, ROOM 1274, O&C BUILDING  
NASA/KSC  
MAY 29, 1990

SUBJECT: TPS Debris, OV-103 (Discovery)

LABORATORY REQUEST NO: MCB-0383-90

RELATED DOCUMENTATION: Intercenter Debris Team Requirements

1.0 FOREWORD:

1.1 REQUESTER: R. F. Speece/TV-MSD-22/7-0806

1.2 REQUESTER'S SAMPLE DESCRIPTION: The samples were from OV-103 (Discovery), Mission STS-31R landing at DFRF/EAFB. The samples were identified as follows:

- Sample #1. Surface wipes from R/H RCC panels #4 and #5.
- Sample #2. Surface wipes from L/H RCC panel #5.
- Sample #3. Brown residue from OML of tile V070-395008-127.
- Sample #4. Material from damage site in tile V070-391003-154.
- Sample #5. Material from damage site in tile B070-394032-427.
- Sample #6. Material removed from LH2 ET/Orbiter umbilical plate surface.
- Sample #7. Material removed from LO2 ET/Orbiter umbilical plate surface.
- Sample #8. Fastener recovered from runway surface.

1.3 REQUESTED: Identify composition of samples and compare to known STS materials.

2.0 CHEMICAL ANALYSIS AND RESULTS:

2.1 Procedure:

The submitted samples were analyzed by means of optical microscopy (OM), infrared spectrometry (IRS), and electron microprobe with energy dispersive spectrometry (EDS).

2.2 Results:

2.2.1 The particulates from each sample were classified into components on the basis of color and texture by OM. The classified components from all samples are listed in Table 1 with the possible identification of each component and elemental analysis.

Table 1

Component ID	Possible Ident.	Elemental Analysis by EDS*	
		Major	Minor
1. Metallics	Al,C-Steel	Al,Fe	
2. Black Tile	Black Tile	Si	
3. White Tile	White Tile	Si	
4. Black Mtls	Dust, Rust	Fe,Si,Ca,S	Al,Cr,Zn,Cl
5. Red Mtls	Primer	Fe,Pb,Cr	Cl,S,Fe,Ti,Si
6. Lgt.Grey Mtls	Paint	Ti,Fe,Org.	Al,Si,Cr
7. Amber Flake	Muscovite	Si,K,Al,Fe	Ti,Mg
8. Glass Fiber	Si-Al Glass	Si,Al	
9. Foam	Foam	Polyurethane	
10. Red Rubbery	RTV	Fe,Si	
11. Organics	Polyamide,PVC Copolymer,		Polyethylene,
12. Organic Fiber	Cellulose materials		

\*: O,C,H, and B are not detectable by using this technique.

2.2.2 Table 2 lists estimated amounts of each component versus sample number.

Table 2

Sample No. Components	#1	#2	#3	#4	#5	#6	#7
1. Metallics	T(Al)	T(Al,Fe)	X	X	X	X	X
2. Black Tile	2	1	95	X	T	X	X
3. White Tile	X	X	X	100	100	X	X
4. Dust, Rust	3	3	X	X	X	X	X
5. Primer	1	X	X	X	X	X	X
6. Paint	1	X	5	X	X	X	X
7. Muscovite	1	1	T	T	X	X	X
8. Si-Al Glass	T	T	X	X	X	X	X
9. Foam	X	3	X	X	X	20	50
10. RTV	X	X	X	X	T	X	X
11. Organics	92	92	X	X	X	80	50
12. Organic Fiber	T	T	X	X	X	X	X
Particle Size, um	1- 5000	1- 7000	1- 2000	1- 400	1- 3000	1- 3000	1- 2000

2: Estimated Volume Percent.

X: Not detected.

T: Trace.

### 3.0 CONCLUSIONS:

- 3.1 The sample numbers 1 and 2 contained Al-particles, and Al-particle and carbon steel.
- 3.2 The sample numbers 1, 2, 3, and 5, and sample numbers 4 and 5 contained black and white tiles, respectively.
- 3.3 The sample numbers 1 and 2 contained dust and rust particles.
- 3.4 The sample number 1 contained primer, and the sample numbers 1 and 3 contained paint particles.
- 3.5 The sample numbers 1 through 4 contained muscovite  $[KAl_2(AlSi_3O_{10})(OH)_2]$ .
- 3.6 The sample number 1 through 3 contained Si-Al rich high temperature insulation glass.
- 3.7 The samples 2, 6, and 7 contained foam. The foam was identified to be polyurethane foam.
- 3.8 The sample number 5 contained trace amounts of room temperature vulcanizing rubber (RTV).



- 3.9 The sample numbers 1, 2, 6, and 7 contained organics. The organics from sample numbers 1 and 2 were composed of white flaky polyamide materials (a nylon 6 resin), orange specks PVC copolymer (wire insulation resin), brownish black flaky polyethylene and clear colorless flaky cellulose acetate. The organic fibers from the sample numbers 1 and 2 were not analyzed at this time.
- 3.10 The particle sizes were estimated to be in the range of 1 to 7000 micrometer.
- 3.11 The composition of fastener from sample #8 was composed of Ti and Al. The composition of the green primer coating on fastener head was composed of Si, Sr, Ti, and Cr with small amounts of S, Cl, Ca, and K. The composition of the green primer coating on fastener head appeared to be not related to the primers used on STS hardware.

CHEMIST: H. S. Kim  
H. S. Kim

APPROVED: J. F. Jones  
J. F. Jones

## 11.0 POST LAUNCH ANOMALIES

Based on the debris inspections and film review, 11 Post Launch Anomalies were observed for STS-31R.

### 11.1 POST LAUNCH PAD DEBRIS INSPECTION

1. The holddown post shim material was 100 percent debonded on HDP #1 and #2. Partial debonding of the shim sidewall material occurred on HDP #5 and #6.

### 11.2 FILM REVIEW

1. SSME ignition acoustics/vibration caused small pieces of surface coating material to fall from tiles on the base heat shield, the RCS stinger aft face, and the trailing edge of the rudder speed brake. In addition, one Q-felt plug fell from the LH RCS stinger.

2. One piece of ordnance debris measuring 3.5 x 0.25 inches fell from the RH SRB aft skirt HDP #1 stud hole shortly after liftoff.

3. Excessive slack in the GH2 vent line static retract lanyard contacted the GUCP during latchback.

4. A total of 7 pieces of aft skirt instafoam, the largest measuring 5 inches in length, broke loose from the HDP #5 and #7 areas and near the LH SRB HPU exhaust port shortly after liftoff. Twenty-seven particles, most likely instafoam, fell from the RH SRB aft skirt area after the roll maneuver.

### 11.3 SRB POST FLIGHT/RETRIEVAL INSPECTION

1. There were 5 MSA-2 debonds over fasteners on the RH frustum and 7 similar debonds on the LH frustum.

2. Localized areas of Hypalon paint were blistered with layers of MSA attached to the Hypalon. The mass of any paint flakes that come off is increased accordingly and will damage Orbiter tiles.

3. Three cracks in the K5NA field joint closeouts were observed at:

1) center field joint	150 degrees	0.70 inches long
2) center field joint	150 degrees	0.75 inches long
3) aft field joint	150 degrees	1.20 inches long

4. Two K5NA protective domes were missing from bolt heads on the aft side of the phenolic kick ring. The substrate was sooted.

5. The HDP #1 DCS plunger had not seated properly and a considerable amount of ordnance debris was lost in flight.

#### **11.4 ORBITER POST LANDING INSPECTION**

1. A 3 x 2 inch tile corner in the Y star tracker cavity was broken and loosely attached.



# Report Documentation Page

1. Report No.		2. Government Accession No.		3. Recipient's Catalog No.	
4. Title and Subtitle  Debris/Ice/TPS Assessment and Photographic Analysis for Shuttle Mission STS-31R				5. Report Date  May 1990	
				6. Performing Organization Code	
7. Author(s)  Gregory N. Katnik Scott A. Higginbotham J. Bradley Davis				8. Performing Organization Report No.	
				10. Work Unit No.	
9. Performing Organization Name and Address NASA External Tank Mechanical Systems Division Mail Code: TV-MSD-22 Kennedy Space Center, Florida 32899				11. Contract or Grant No.	
				13. Type of Report and Period Covered	
12. Sponsoring Agency Name and Address				14. Sponsoring Agency Code	
15. Supplementary Notes					
16. Abstract  A Debris/Ice/TPS assessment and photographic analysis was conducted for Space Shuttle Mission STS-31R. Debris inspections of the flight elements and launch pad are performed before and after launch. Ice/frost conditions on the External Tank are assessed by the use of computer programs, nomographs, and infrared scanner data during cryogenic loading of the vehicle followed by on-pad visual inspection. High speed photography is analyzed after launch to identify ice/debris sources and evaluate potential vehicle damage and/or in-flight anomalies. This report documents the debris/ice/TPS conditions and photographic analysis of Mission STS-31R, and their overall effect on the Space Shuttle Program.  <i>IS PRESENTED ALONG WITH</i>					
17. Key Words (Suggested by Author(s))  STS-31R Frost Thermal Protection System (TPS) Photographic Analysis			18. Distribution Statement  Ice Debris Publicly Available Unclassified - Unlimited		
19. Security Classif. (of this report)  Unclassified		20. Security Classif. (of this page)  Unclassified		21. No. of pages	22. Price