

NASA Contractor Report 182065

STRUCTURES FOR REMOTELY DEPLOYABLE PRECISION ANTENNAS

John M. Hedgepeth

**ASTRO AEROSPACE CORPORATION
Carpinteria, California**

**Contract NAS1-18567
January 1989**

(NASA-CR-182065) STRUCTURES FOR REMOTELY
DEPLOYABLE PRECISION ANTENNAS Final Report
(Astro Aerospace Corp.) 55 p USCL 22P

N90-26061

63/18 Unclss
0297005



National Aeronautics and
Space Administration

Langley Research Center
Hampton, Virginia 23665-5225



STRUCTURES FOR REMOTELY DEPLOYABLE
PRECISION ANTENNAS
FINAL REPORT

by

John M. Hedgepeth

AAC-TN-1154

16 January 1989

Prepared for

National Aeronautics and Space Administration
Langley Research Center
under
Contract No. NAS1-18567
Task 4

Prepared by

Astro Aerospace Corporation
6384 Via Real
Carpinteria, CA 93013-2993



TABLE OF CONTENTS

SECTION 1:	INTRODUCTION	1
SECTION 2:	STRUCTURAL REQUIREMENTS	4
	2.1 Reflecting Surface	4
	2.2 Supporting Structure	4
	2.3 Shape Control	6
	2.4 Influence of Beam Steering and Band Switching on Structural Requirements	6
	2.5 Packaging	7
SECTION 3:	DEPLOYABLE STRUCTURAL CONCEPTS	9
	3.1 Reflecting Surface	9
	3.2 Supporting Structure	10
SECTION 4:	PANEL DESIGN	28
SECTION 5:	VARIABLE GEOMETRY	33
SECTION 6:	CONCLUDING REMARKS	36
REFERENCES:	37
APPENDIX A:	A-1

LIST OF ILLUSTRATIONS

Table 1.	Reflector Corrections for Scan	34
Figure 1.	Large space antenna requirements	2
Figure 2.	Example of multiband high-frequency radiometer antenna . .	5
Figure 3.	Symmetric and offset-fed antenna reflector configurations	11
Figure 4.	Main panel double ring configuration	13
Figure 5.	View showing the first panel rotated out with its tips displayed and lowered for lockup on the center hexagonal hub	14
Figure 6.	Extendible support structure for SEASAT synthetic aperture radar antenna	16
Figure 7.	ESS deployment sequence	17
Figure 8a:	Synchronously deployable Concept B (CREST) for stiff-panel reflectors	18
Figure 8b:	Synchronously deployable Concept B (CREST) for stiff- panel reflectors	19
Figure 9.	Deployable reflector for FIRST (Dornier System)	20
Figure 10.	Automated curved surface construction concept	21
Figure 11.	PACTRUSS concept	22
Figure 12.	Sequentially deployable precision reflector	24
Figure 13.	The basic truss module	25
Figure 14.	Views of Pactruss for offset paraboloid	26
Figure 15.	Antenna surface error caused by identical spherical panels	31
Figure 16.	Worst case residual errors after best adjustment of panel	35

SECTION 1

INTRODUCTION

Future space missions such as the Earth Science Geostationary Platform (ESGP) will require highly accurate antennas with apertures that cannot be launched fully formed. The operational orbits are often inaccessible to manned flight and will involve expendable launch vehicles such as the Delta or Titan. There is therefore a need for completely deployable antenna reflectors of large size capable of efficiently handling millimeter wave electromagnetic radiation.

The parameters for the type of mission considered herein are illustrated by the heavy shaded horizontal bars in Figure 1. This logarithmic plot of frequency versus aperture diameter shows the regions of interest for a large variety of space antenna applications, ranging from a 1500-meter-diameter radio telescope for low frequencies (less than 10 MHz) to a 20-meter-diameter infrared telescope. For the ESGP, a major application is the microwave radiometry at high frequencies (up to 220 GHz) for atmospheric sounding. The heavy lines in Figure 1 occur at peaks and windows of the absorption spectra and are useful for the determination of atmospheric temperature, clouds, water vapor and precipitation; the width of the lines denotes the bandwidth of interest. The aperture diameters start at 4 meters, the size which can be launched without folding, and range up to the size yielding a resolution at the Earth's surface of about 6 km.

In the figure, only those frequency bands above 30 GHz are shown. These higher frequencies require a solid reflector surface, perhaps segmented or inflated. On the other hand, the lower frequencies can be reflected efficiently by expandable mesh surfaces.

Almost all existing large antenna reflectors for space employ a mesh-type reflecting surface. Examples are shown and discussed in Reference 1, which deals with the various structural concepts for mesh antennas. Fortunately, those concepts are appropriate for creating the very large apertures required at the lower frequencies for good resolution.

The emphasis of this paper is on the structural concepts and technologies that are appropriate to fully automated deployment of dish-type antennas with solid

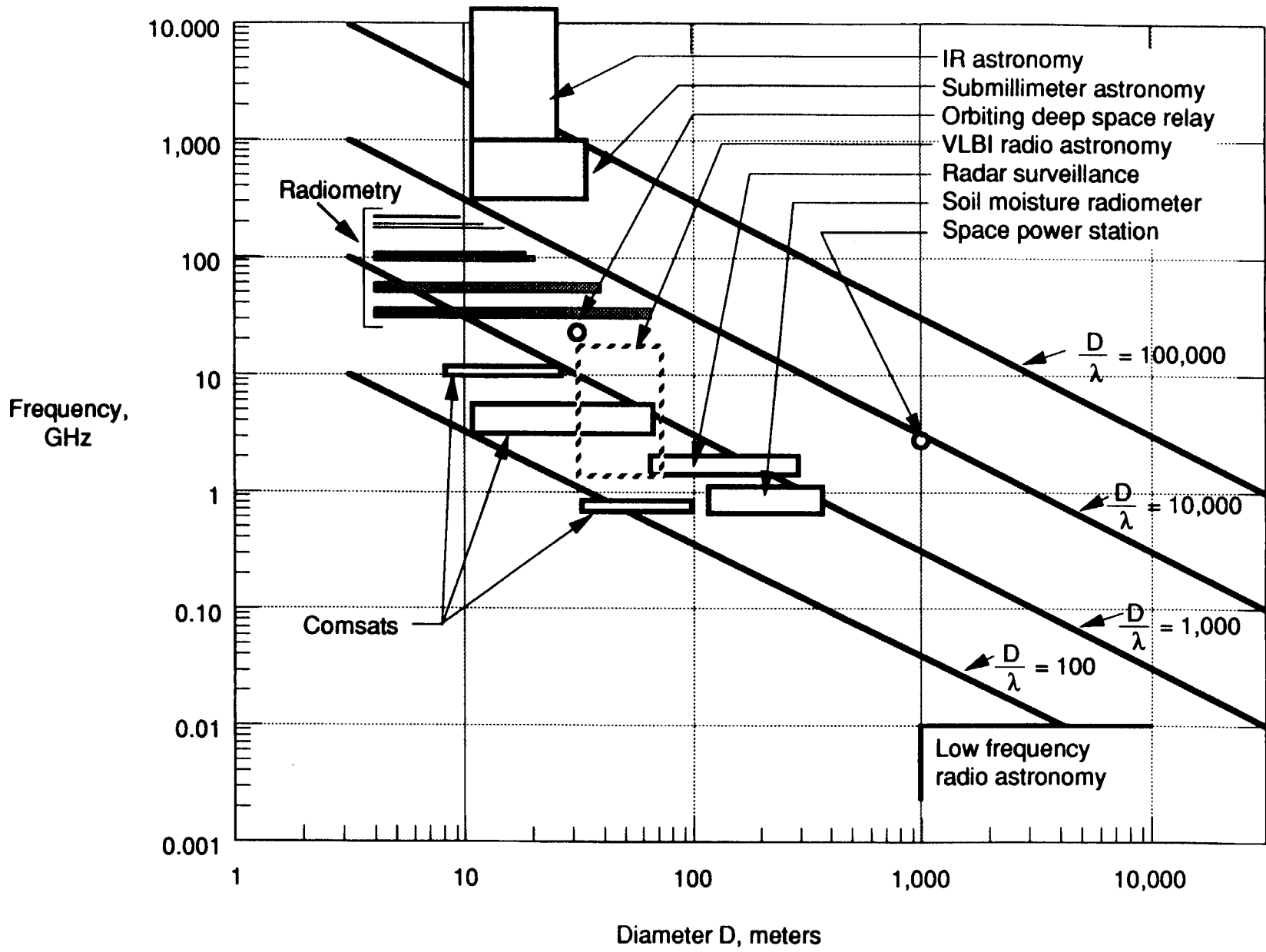

2

Figure 1. Large space antenna requirements.

reflector surfaces. First the structural requirements are discussed. Existing concepts for fully deployable antennas are then described and assessed relative to the requirements. Finally, several analyses are presented that evaluate the effects of beam steering and segmented reflector design on the accuracy of the antenna.

SECTION 2

STRUCTURAL REQUIREMENTS

A probable configuration for the high frequency radiometer antenna is shown in Figure 2. It consists of a primary reflector dish, a subreflector, and more than one feed system. For a structural point of view, each reflector consists of a reflecting surface and a structure to hold the reflecting surface in shape and position. In some cases, the two functions can be combined, but it is helpful to consider them separately.

2.1 REFLECTING SURFACE

Passive microwave radiometers must have very high efficiency because of the feebleness of the received signal. Thus, the reflecting surface must cause minimum loss. This requires a surface of high conductivity. The surface can be very thin electrically because the skin depth of the surface currents is very small (much less than one micrometer). If the surface is a grid, low loss requires that the grid spacing be a small fraction of the wavelength λ , say $\lambda/50$. Similarly, the surface must be smooth, with roughness less than $\lambda/50$ for undulations having a spatial period of a half wavelength or more. Thus, the compliant knitted mesh that readily stows into a small package is not suitable for frequencies greater than about 30 GHz. Breaks or gaps in the reflecting surface are acceptable if they are many wavelengths apart and if the large ones do not form a regular pattern.

2.2 SUPPORTING STRUCTURE

The supporting structure must be made sufficiently accurate, stiff, and dimensionally stable in order to meet the stringent requirements for diffraction-limited antenna performance. Not only must the antenna be efficient, but also must it exhibit small side lobes. Analysis (see Reference 2) shows that large-correlation-distance surface errors with an rms of $\lambda/50$ can raise the near-in side lobes by as much as 20 dB down from the main lobe. In addition, any distribution of surface normal errors with an rms of $\lambda/50$ will reduce the main-lobe efficiency by six percent. It appears, therefore, that a demanding mission such as microwave radiometry requires a smaller rms error, probably $\lambda/100$.

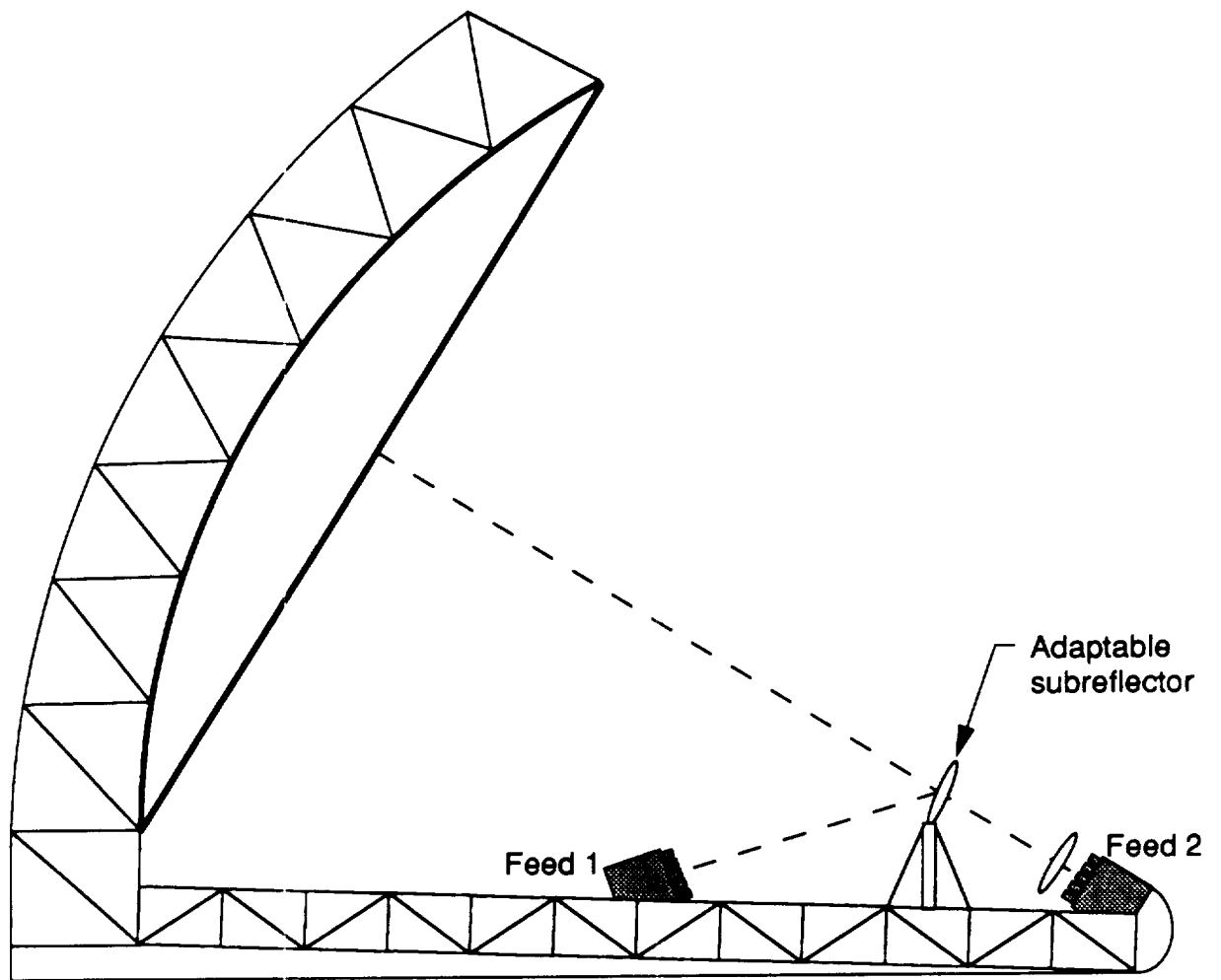

Figure 2. Example of multiband high-frequency radiometer antenna.

The ratio of rms error δ to aperture diameter D can be obtained as a function of the ground resolution as follows:

Let R be the range (36,000 km) and r be the resolution in kilometers. Then

$$\frac{r}{R} = 1.3 \frac{\lambda}{D}$$

Setting $\lambda = 100\delta$ and solving for δ/D yields

$$\frac{\delta}{D} = 0.214 \times 10^{-6} r$$

For example, for a ground resolution of 20 km, the value of $\delta/D = 4.3 \times 10^{-6}$. For a 20 m aperture, $\delta = 85$ micrometers. On the other hand, for a resolution of 6 km and an aperture of 10 m, then $\delta = 12.8$ micrometers.

Clearly, very high accuracies will be demanded from the supporting structure for the high-frequency radiometry missions in Figure 1.

2.3 SHAPE CONTROL

Some shape control is likely to be needed to obtain the required surface accuracies. Initial trimming in orbit will probably be desirable, if only to reduce the expense of testing before flight. Also, provision should be made to adjust the antenna figure to cope with long-term changes in the materials due to exposure.

A worthwhile objective will be to make the structure stiff enough and thermally stable enough that it can handle all the short-term excitations without deforming too much. Then the shape control system can be of the updating type and much less expensive than a full authority system would be.

2.4 INFLUENCE OF BEAM STEERING AND BAND SWITCHING ON STRUCTURAL REQUIREMENTS

The radiometer must be able to direct its beam to any part of the earth's disk; thus, it needs to scan about 8 degrees off axis. In addition, the scan must be rigid; in order to achieve the desired frequency of coverage, a scanning rate of hundreds of degrees per minute is needed. This will cause unacceptable shaking of the spacecraft if the scan is entirely mechanical.

Therefore, the beam steering will need to be achieved mostly by electronic scanning. The simplest way to accomplish this is to move the effective feed point by varying the gain on individual feed elements (horns, perhaps) in a multi-element feed array. Unfortunately, steering the beam by feed movement results in large errors for angles more than ten to twenty beam diameters off axis. In order to cover the earth, nearly 1,000 beam diameters need to be scanned.

Of course, the art of antenna engineering is able to achieve much smaller errors. One approach, for example, is to design subreflector and reflector geometries so as to minimize errors during scan. Another approach that shows promise is to use a phased array to illuminate the subreflector. Another possibility is to scan rapidly electrically in one direction while slowly moving the entire antenna mechanically in the perpendicular direction to cover the desired area.

In addition to steering, the several frequency bands also must be examined. The frequency range from 30 to 220 GHz is obviously too much to be handled with a single feed system. Multiple systems will be required, and their location will pose severe problems, especially since they will have to be large in order to produce the ± 8 degree scan.

Beam and frequency agility is the responsibility of the antenna engineer. From the structural point of view, the need for low spacecraft excitation also implies that the dynamic loads on the antenna reflectors will be low. It might be possible to ease the beam steering problem by actively shaping the subreflector and/or the primary reflector. The amounts of displacements required to eliminate the path length error are estimated later in the paper.

Finally, provision of the needed beam steering with multiple feed systems may result in new geometrical configurations for which new structural concepts will be required.

2.5 PACKAGING

The microwave radiometer operates in geosynchronous orbit. For the purposes of this paper, the assumption is made that the deployment will be in geosynchronous orbit and therefore remote. The launch system is assumed to be

either the Titan IV or a Shuttle-OTV combination, with cargo-bay diameter of 4.5 meters and an available length of over 10 meters. The Delta launch vehicle, with its smaller launch volume and lower payload, appears to be inapplicable for the ESGP mission.

SECTION 3

DEPLOYABLE STRUCTURAL CONCEPTS

As in the preceding section, it is convenient to discuss concepts for the reflecting surface first.

3.1 REFLECTING SURFACE

The requirement that the reflecting surface be solid limits consideration to reflective membranes and panels.

Membrane surfaces can be excellent radio-frequency reflectors. Some care must be taken to ensure that the surface conductivity of metalized plastic films is not degraded by cracks in the conductive layer caused by frequent creases. For dish-type surfaces, the membrane requires a transverse pressure loading to create a wrinkle-free surface of the correct shape. No suitable reflector membrane material has low enough in-surface stiffness to enable needed changes in Gaussian curvature without incurring high stresses. Membranes are pliable and can be stowed compactly.

The most prevalent approach for providing a reflector surface is to use an assemblage of stiff panels. A variety of shapes have been proposed, ranging from near-hexagonal segments, through ring sectors, to petals. In all cases, the panels butt together to produce the large dish-type reflector. For launch, the panels are folded or interleaved to fit in the launch vehicle. Each panel is considered to be stiff and precise enough to maintain its own shape. Panels can be built in several ways, the chief ones being as a honey-comb sandwich or a monocoque stiffened shell.

A novel approach that has been suggested by Composite Optics, Inc. of San Diego utilizes a reflector surface composed of a thin flexible shell of graphite-epoxy composite. Large areas of the shell can be rolled up for launch and allowed to unroll in orbit against a supporting truss structure. The shell could comprise the entire surface for smaller antennas. Rolled-up shell segments could be stowed with the folded truss for larger apertures.

3.2 SUPPORTING STRUCTURE

Antenna reflector configurations using membrane reflector surfaces must provide some means for creating a pressure-type loading across the surface. If gas pressure is used, the reflecting surface is usually joined to a symmetrically shaped transparent film around the rim to create a closed pressure vessel. Examples are shown in Figure 3 taken from Reference 3. The rim must be capable of carrying the compression loading caused by the membranes' pulling inward at the rim. The rim may consist of an inflatable torus. The assembly is deployed by slow inflation and is intuitively very reliable.

Leakage caused by meteoroid penetration would necessitate a large supply of make-up pressurant for long time operation. This can be avoided by making the membrane stiff enough to provide its own structural integrity after deployment. The ECHO passive satellite, a 100-foot-diameter balloon, was launched early in the space age. Its shell was composed of a thin sandwich with Mylar-film face sheets and an aluminum-foil core. More recently, technology work in Europe has been underway since the early 1980s developing a Kevlar-epoxy composite surface which is cured and hardened on orbit after inflation. See References 3 and 4.

Inflatable antennas, while being vigorously promoted for the lower frequencies, are generally viewed as being inapplicable for the high frequencies being considered herein. Even when extreme care is exercised during fabrication, the available suitable materials lack the long-term dimensional stability and super-low coefficient of thermal expansion needed for very high precision. In addition, inflatable antennas, once fabricated, are difficult to "tune up," even during ground testing. Adjustments in orbit seem to be impossible.

Membrane antennas shaped and adjusted by electrostatic forces have been proposed and studied during the last decade. This technique shows good promise of being useful, particularly for shallow dishes. Deep dishes are less amenable to this approach because the high in-surface stiffness of the doubly curved membrane causes the shaping pressures to be large. Even for shallow dishes, the necessary electrostatic drivers and their support structure tend to be heavy and the charged devices must be shielded against arcing due to the in-space plasma. On the other hand, rapid adjustment of the lightweight film reflector can be accomplished with little disturbance of the spacecraft.

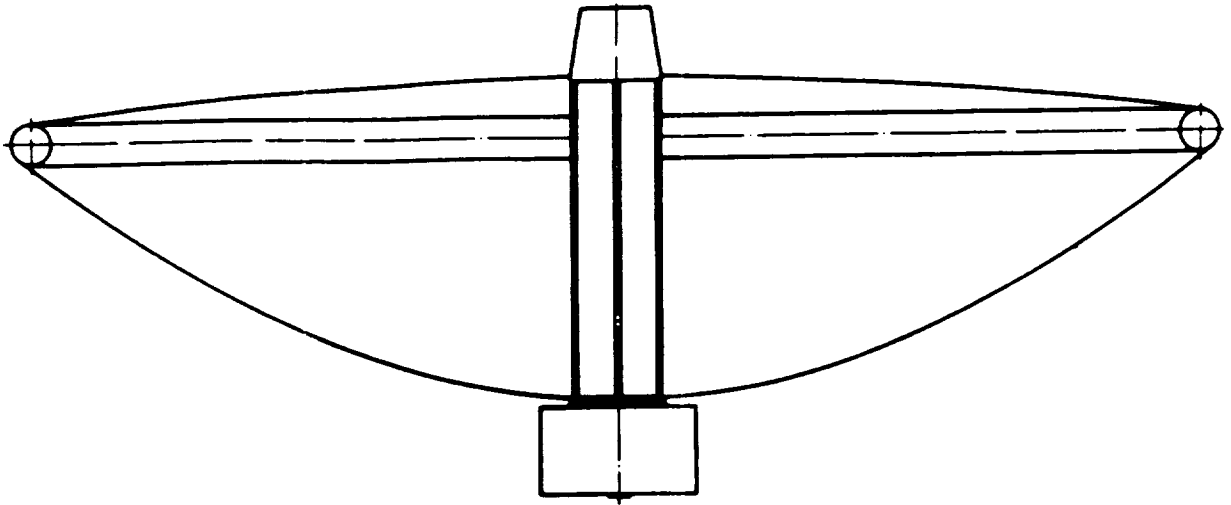

Figure 3a. Symmetric antenna reflector configuration (QUASAT - 20-m aperture).

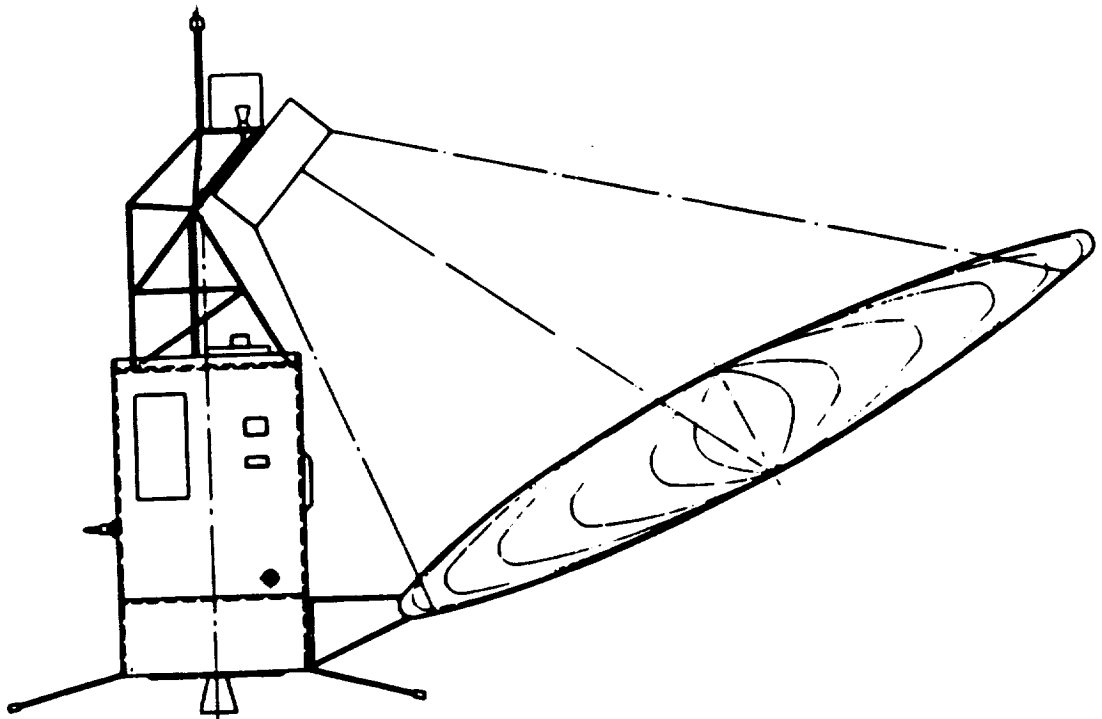

Figure 3b. Offset-fed antenna reflector configuration.

Supporting structures for panel-type reflector surfaces are often integrated with the reflecting surface itself. Indeed, this approach is used for the many solid dishes flying on communication satellites. Its simplicity is attractive and the resulting structure can be made dimensionally stable enough to be used at extremely high frequencies. Ingenious concepts have been devised for deploying large dishes by hinging between adjacent segments. One such technique, termed Sunflower, consists of petals which fold up around the symmetry axis and form a complete dish on deployment. The concept underwent significant development in the 1960s as a space-borne solar-energy collector (see Reference 5). A recently designed descendant is shown in Figure 4. Note that this version deploys to a 15-meter diameter.

Another segmented-panel approach with integrated structure was designed for high-frequency antennas and is discussed in Reference 6. Figure 5, taken from Reference 6, shows the stack of stowed hexagonal panels, each one of which is rotated into position and fastened to its neighbor. Not shown are the mechanisms required to deploy and attach the segments together.

Integrated-structure, or panel-only, concepts are attractive because of their relative simplicity. They also use well established fabrication techniques and appear to be of low risk. They are, however, structurally "thin," so that small errors in individual parts grow into large distortions for large sizes. In addition, such structures are difficult to test in a one-g environment. Their flexibility combines with the gravity loading to produce deflections that are large in comparison to those acceptable for the present application. It is therefore difficult to achieve the desired accuracy, either by fabricating the component parts with enough precision or by "trimming" the structure by adjustments based on measurements obtained during ground testing.

The experience and information obtained by studies and tests over the past two decades have shown that structural configurations that are "deep" are much more suitable for large high-precision surfaces than are the "thin" ones. See References 1, 7, 8, 9, and 10. Not only is this notion intuitively obvious, but also detailed analyses have shown that very high precision is achieved with careful fabrication. For example, a recent simulation of a 20-meter-diameter tetrahedral-truss structure constructed from 2-meter struts which have random lengths with an rms variation of 20 micrometers, showed an

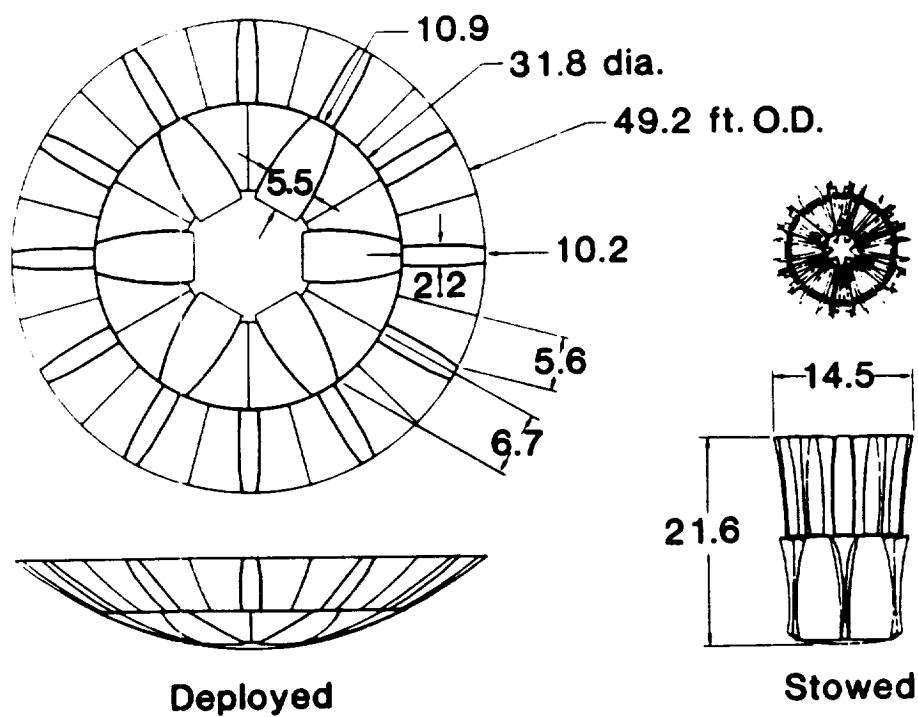

Figure 4. Main panel double ring configuration.

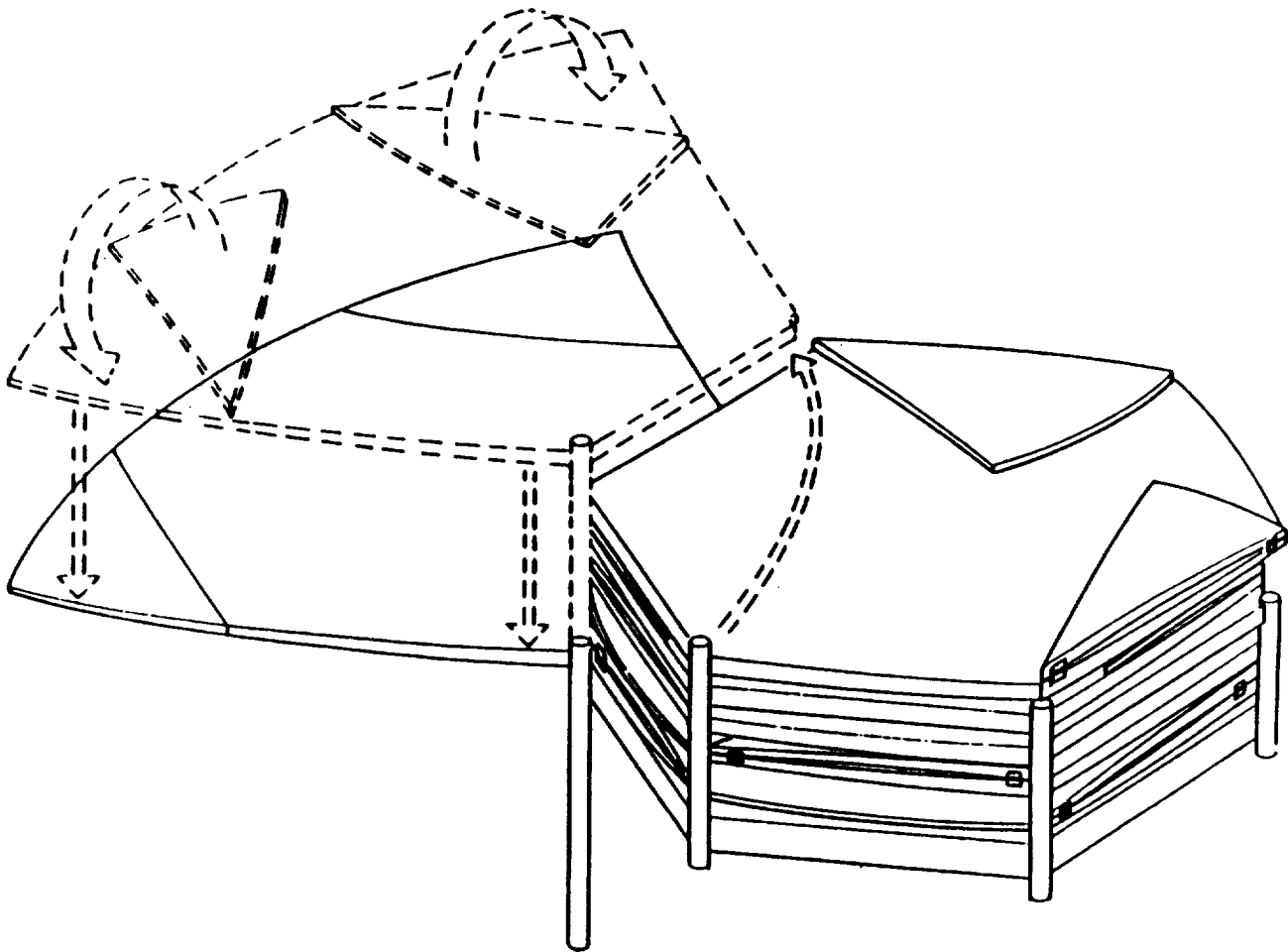

Figure 5. View showing the first panel rotated out with its tips displayed and lowered for lockup on the center hexagonal hub.

expected rms surface error of 43 micrometers. The worst of 100 cases had an rms surface error of 72 micrometers. Furthermore, analysis of the deflections caused by testing in a one-g field showed an rms error of about 100 micrometers; gravity compensation should be able to decrease that by an order of magnitude.

One antenna with a deep-truss support structure flew on the SEASAT spacecraft. As shown in Figure 6, the synthetic aperture radar antenna, which is 10.75 meters long, is supported by a deployable truss. The radiating panels are stowed and deployed with the truss as seen in Figure 7. This structure, which supported an L-band antenna ($\lambda = 20$ cm) was accurate to better than 2.5 mm maximum deflection. This was achieved, and demonstrated with care but without heroic efforts; the robustness of the configuration simplified analysis, integration and testing. Similar deployment truss concepts have been studied for possible use with dish-type reflector antennas. one of these is shown in Figure 8. This arrangement has the advantage that it allows the panel segment to nest, thereby saving package volume.

The structural performance of a petal-type deployable reflector can be greatly improved by mounting each petal on a stiffening truss. The approach has been suggested by Dornier and is shown in Figure 9. The application is an 8-meter reflector for infra-red astronomy. Also being studied for this mission is a segmented three-section mirror in which the outer two segments fold inward over the central one to form an 8-meter-long package with a 4-meter cross section.

The foregoing truss-stiffened concepts are useful only for diameters smaller than the available package length, say up to 10 to 15 meters, depending on the launch vehicle configuration. For larger dishes, it will be necessary to divide the reflector surface in both directions in the surface. This poses a severe problem because almost certainly the surface will have to be cut into segments and stowed separately. The supporting truss can be stowed separately also, and the panels can be assembled to the deployed truss by a robot as shown in Figure 10. Research is in progress at Langley Research Center on such robotic assembly. One concept for the deployable truss which is being extensively studied for various high-precision applications is the Pactruss shown in Figure 11. The deploying truss in this concept is very strongly syn-

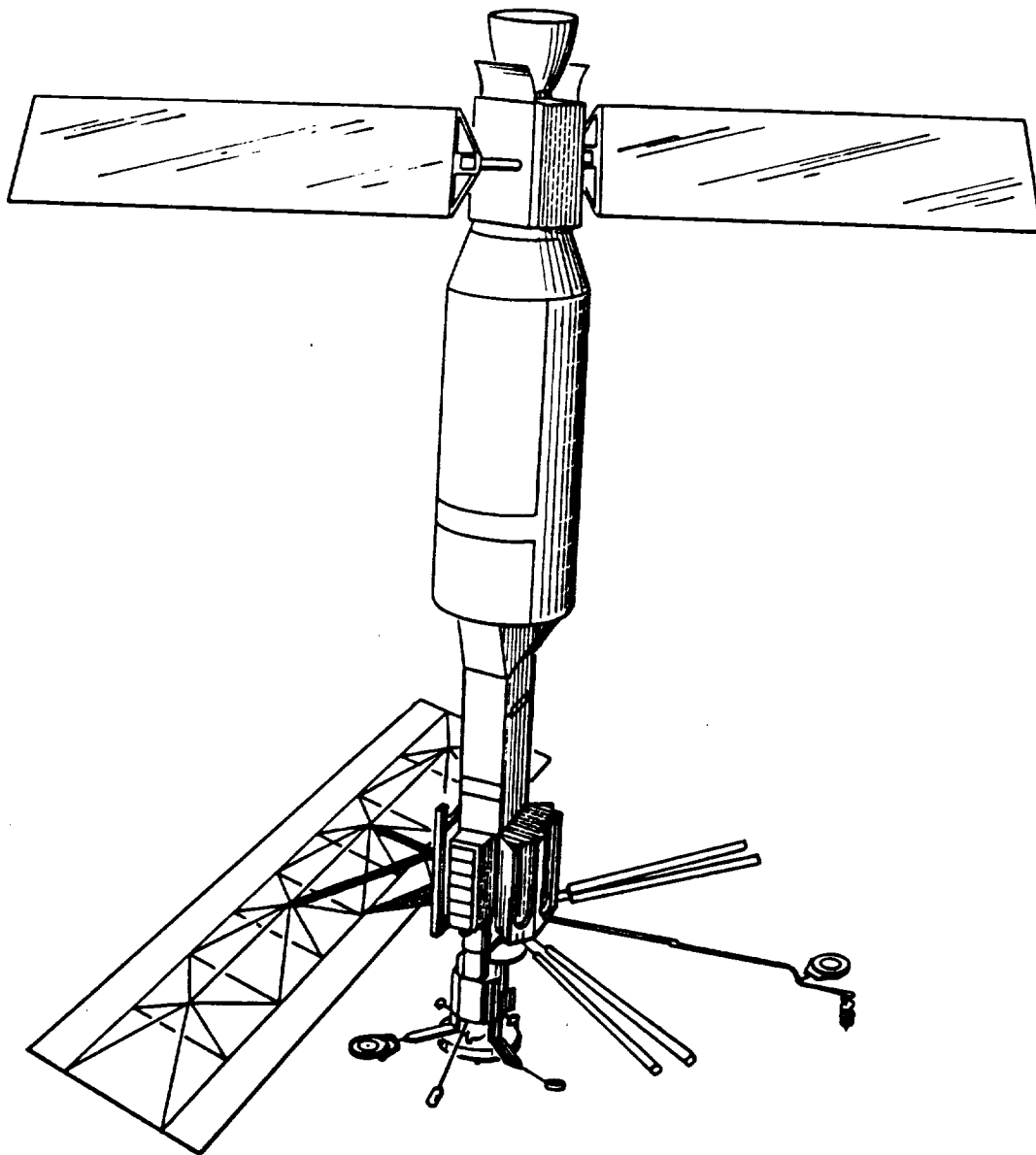

Figure 6. Extendible support structure for Seasat synthetic aperture radar antenna.

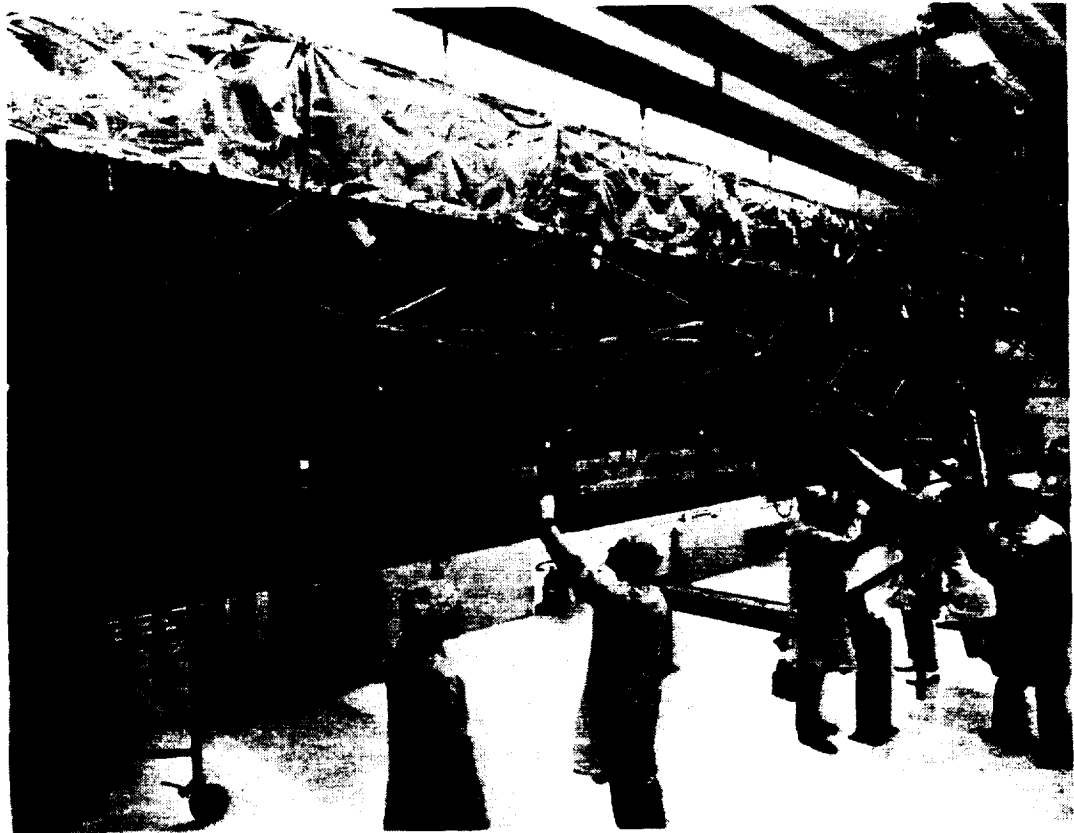
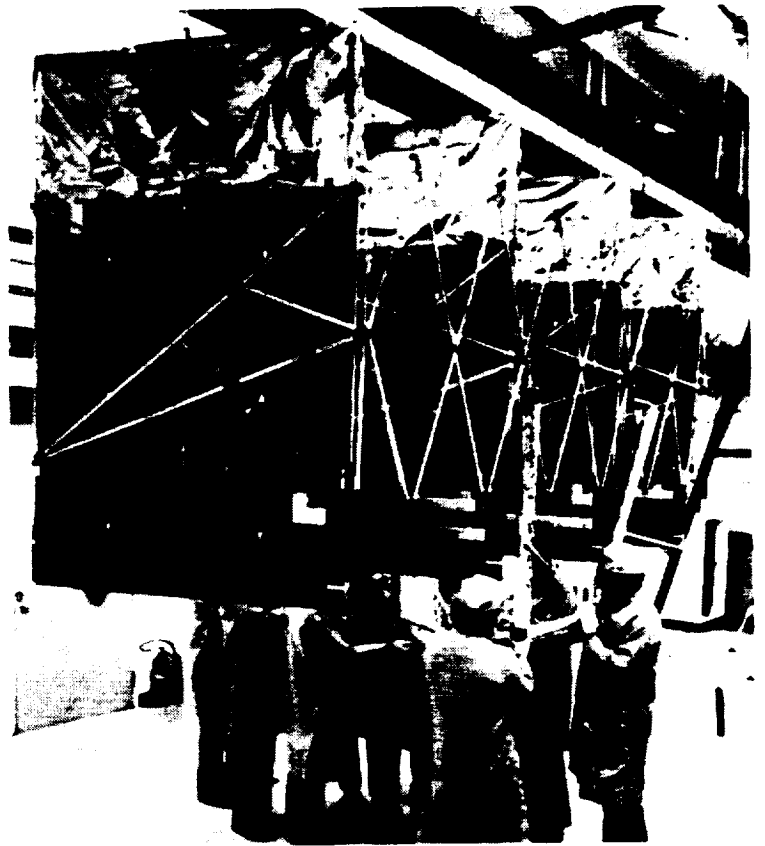
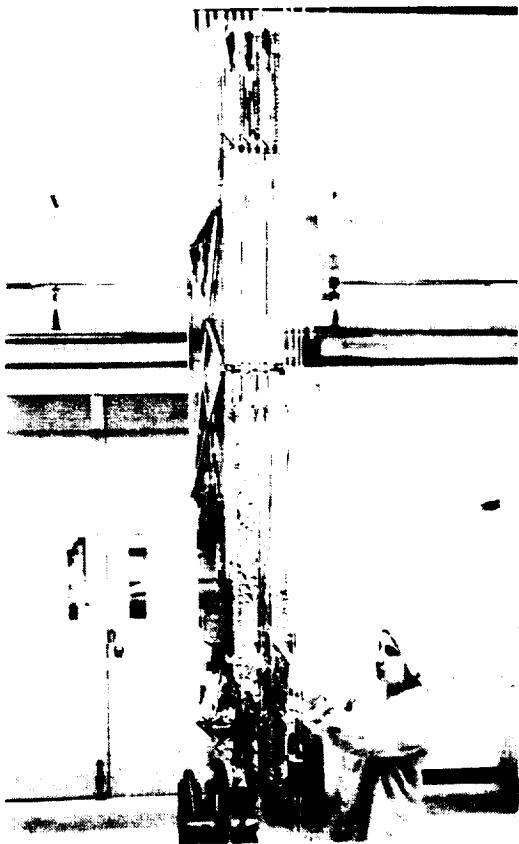

Figure 7. ESS Deployment sequence.

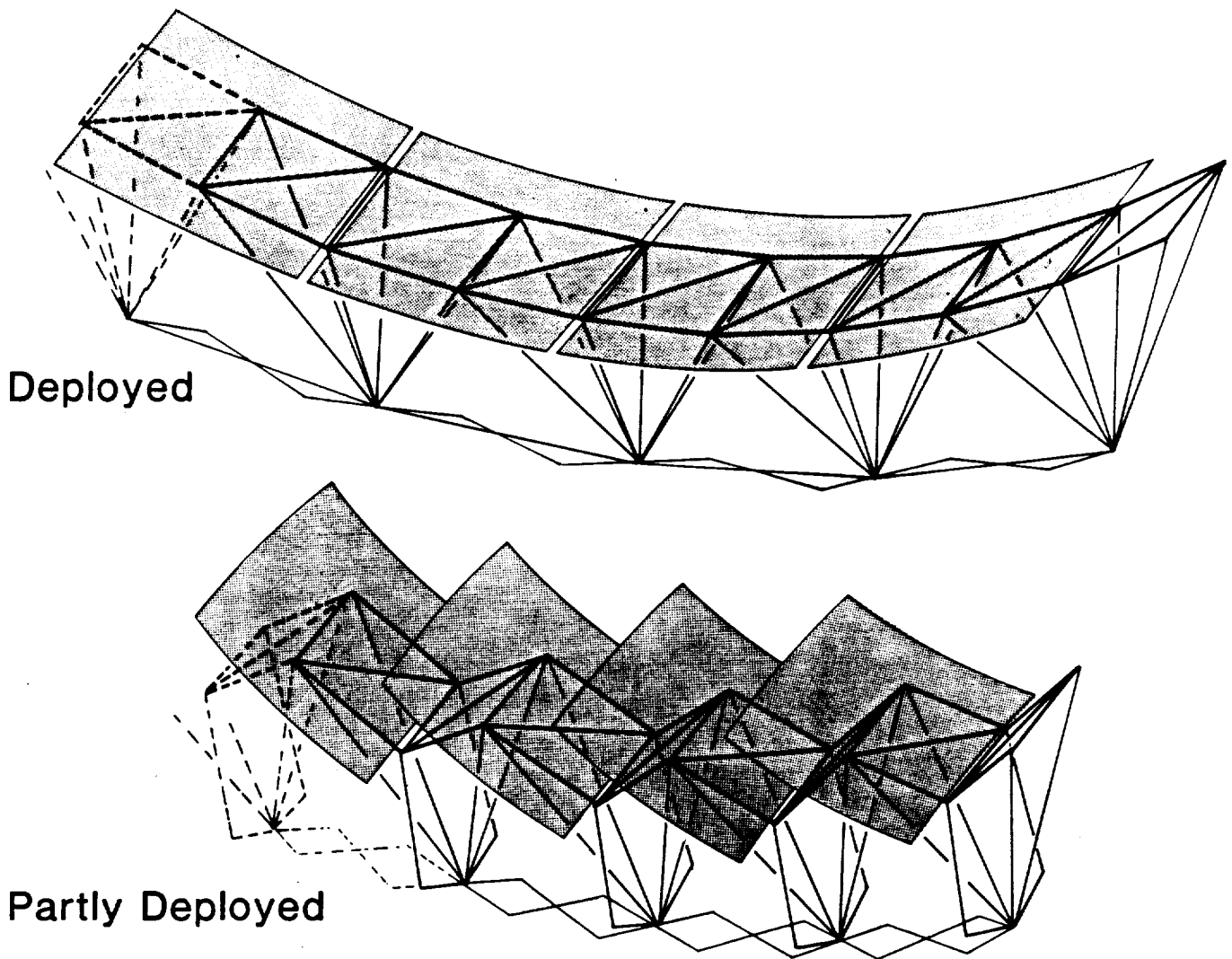
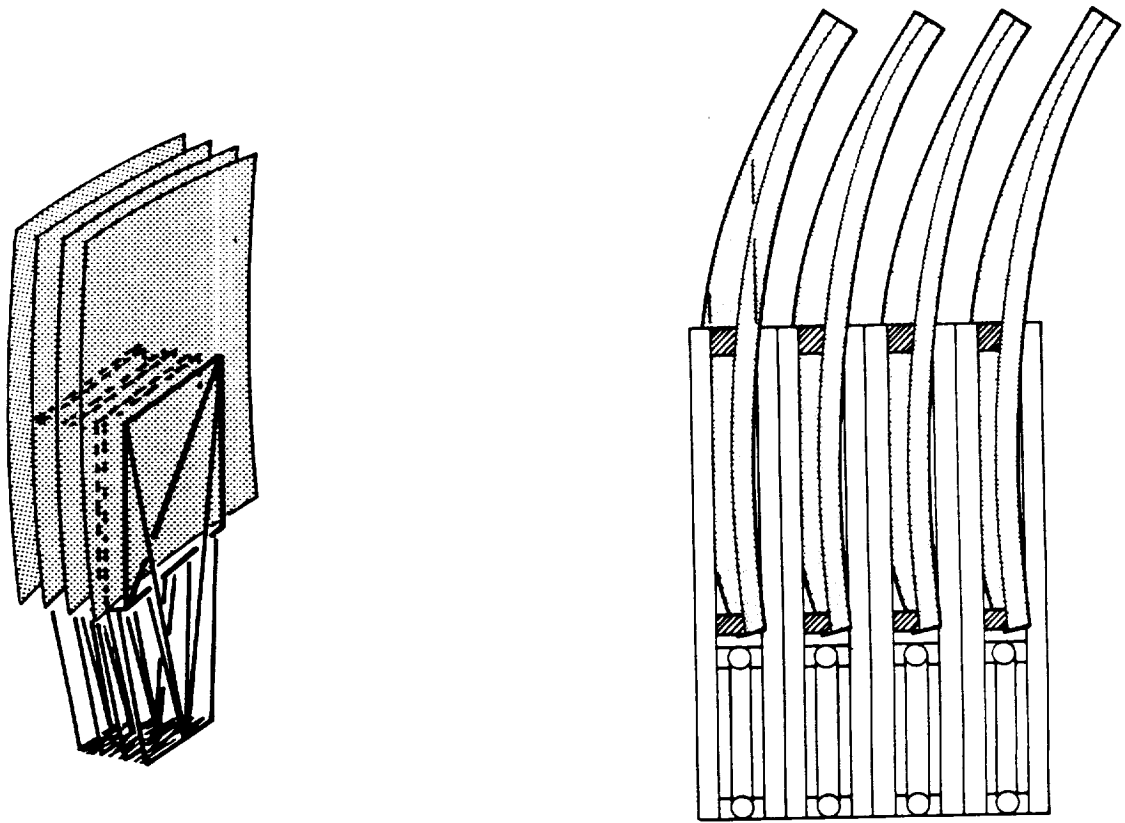
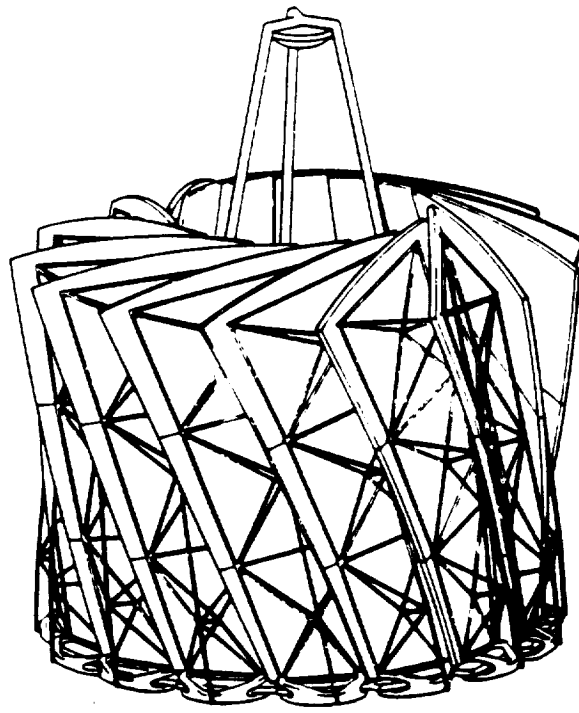

Figure 8a. Synchronously deployable Concept B (CREST)
for stiff-panel reflectors.



Stowed

Figure 8b. Synchronously deployable Concept B (CREST)
for stiff-panel reflectors.



STOWED

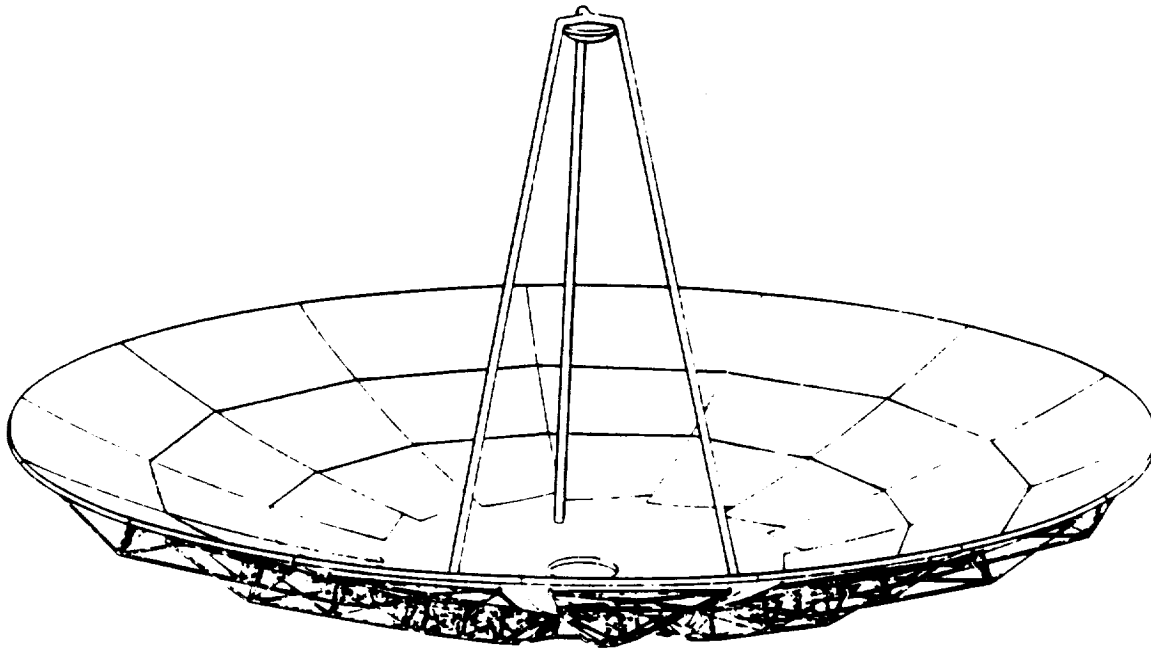

DEPLOYED

Figure 9. Deployable reflector for FIRST (Dornier System).

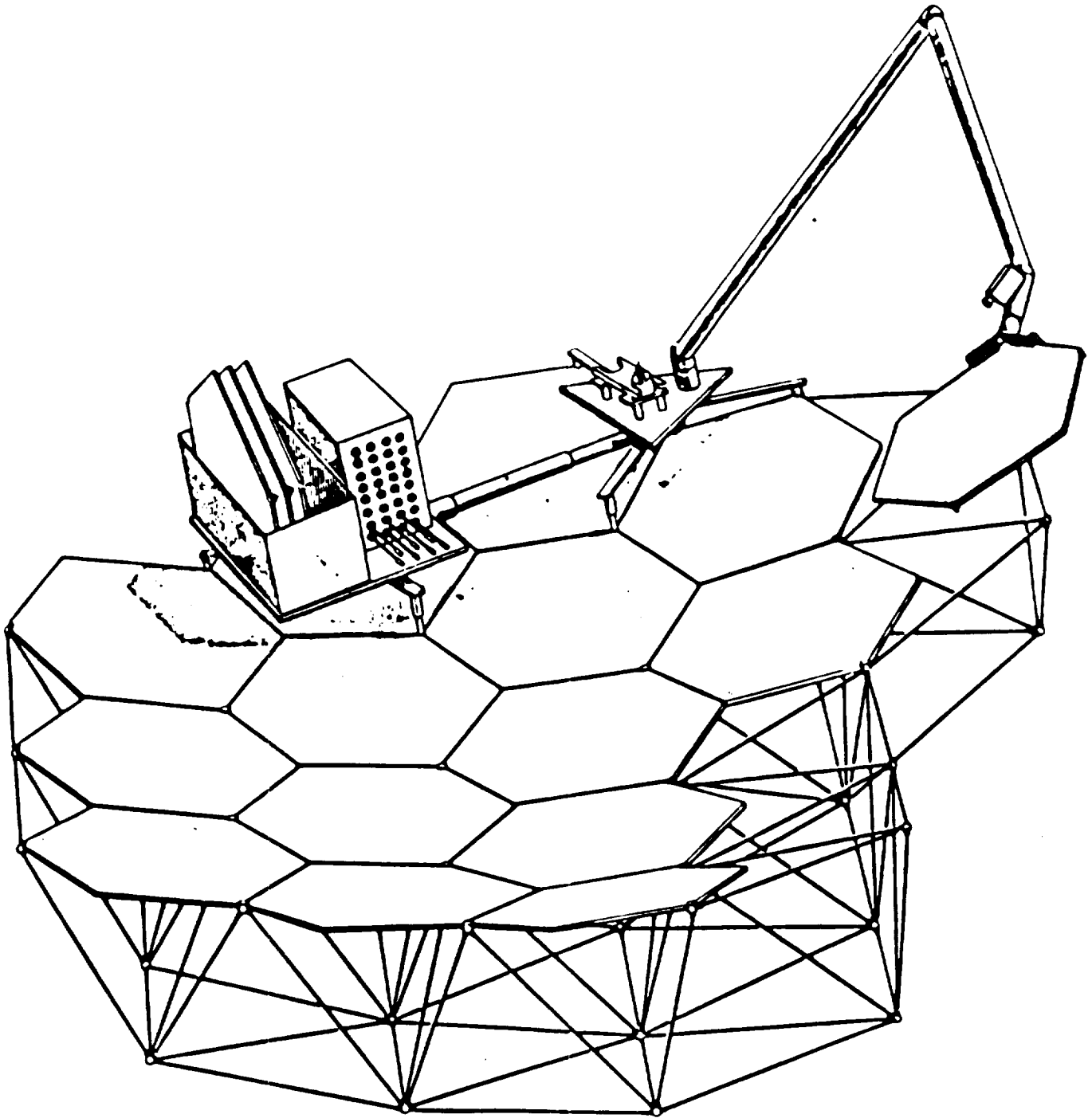

Figure 10. Automated curved surface construction concept.

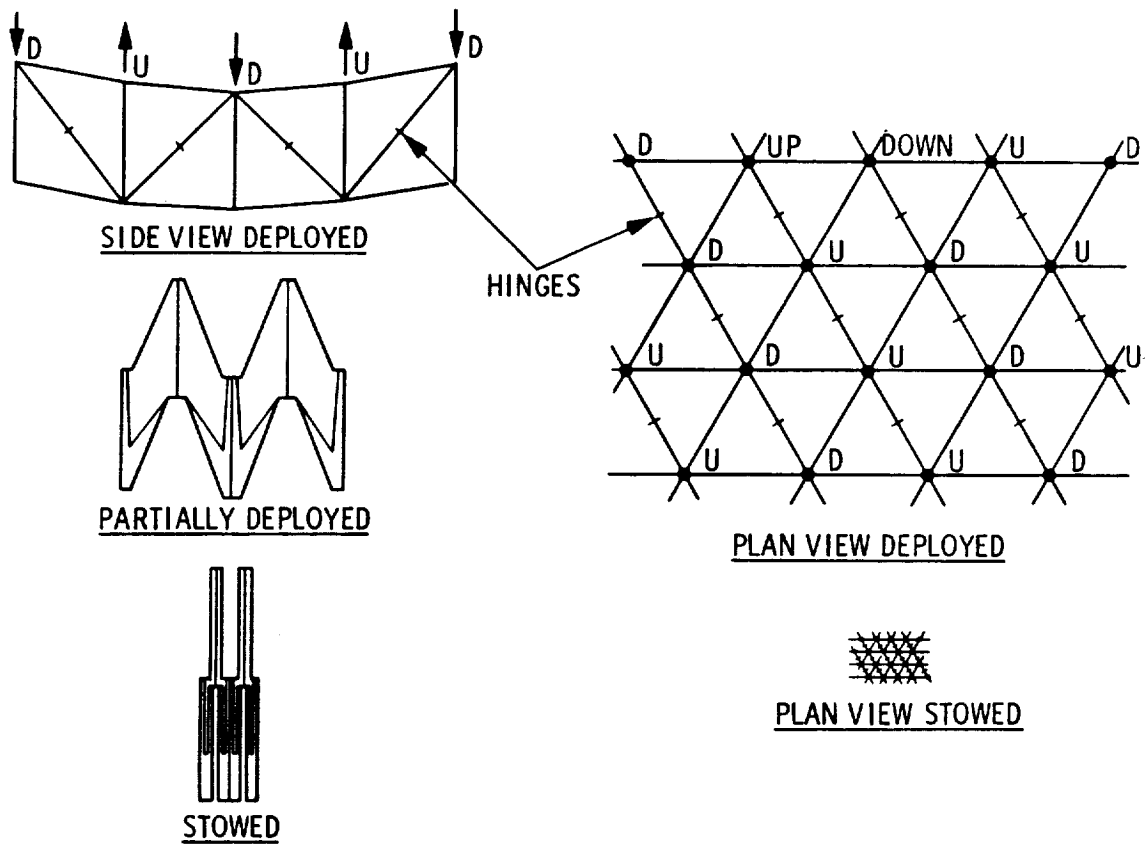

Figure 11. PACTRUSS concept.

chronized and offers reliable deployment with a few actuators. See Reference 11 for the description of recent evaluations of precision application.

Another concept for constructing large segmented reflectors in remote locations is shown in Figure 12. Here, individual modules, each consisting of a panel and its associated support truss section (see Figure 13), are stowed in a deployment canister which walks around the dish, deploying modules and locking each to its neighbors. The development of this intelligent canister would require some effort but seems to be easier than using a robot. Use would be made of the fact that each module would be hinged, so far as possible, to its neighbors. The hinging would aid in control of the canister motions.

The furlable, thin-shell reflector panel described in a foregoing section might be stowable along with the deployable truss. The rolled-up segments could possibly be released after truss deployment and would then settle into frames created by the truss. In this case, the square form of Pactruss would probably be more attractive. The panels would then be nearly square. See Figure 14.

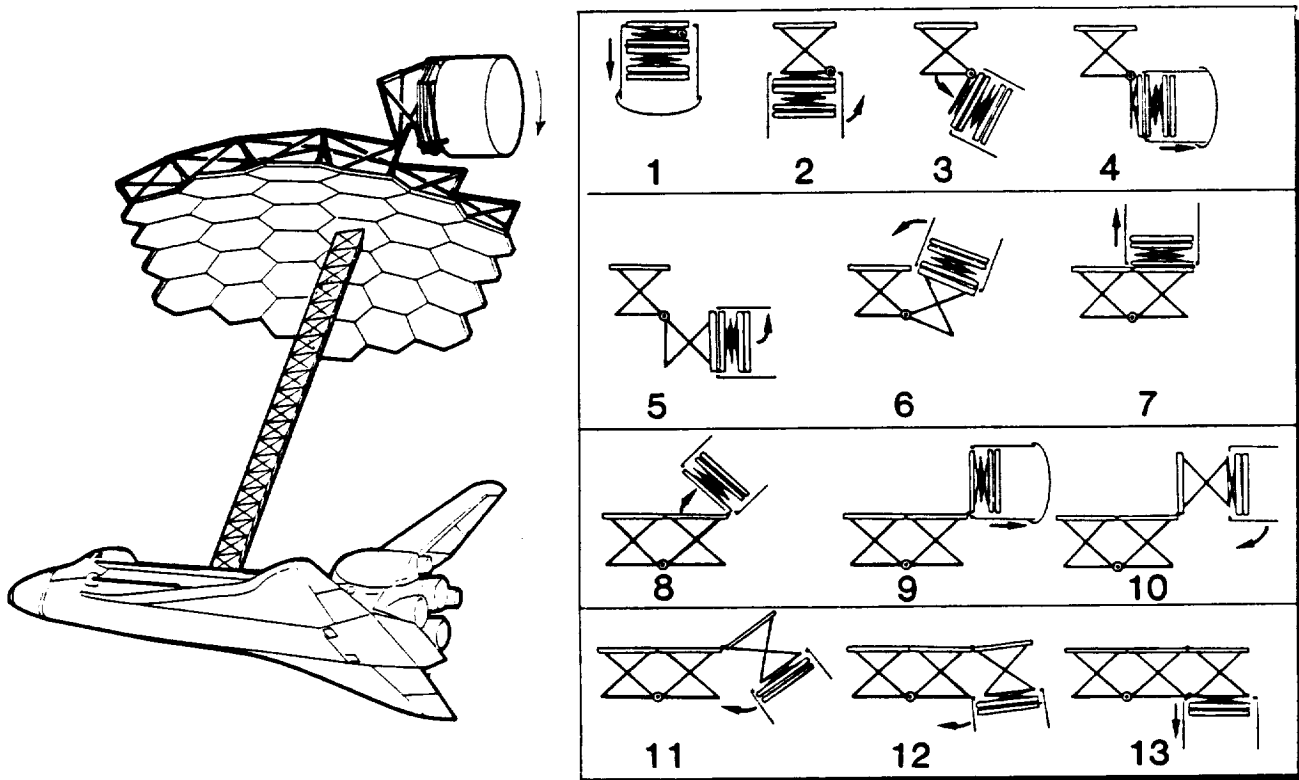

Figure 12. Sequentially deployable precision reflector.

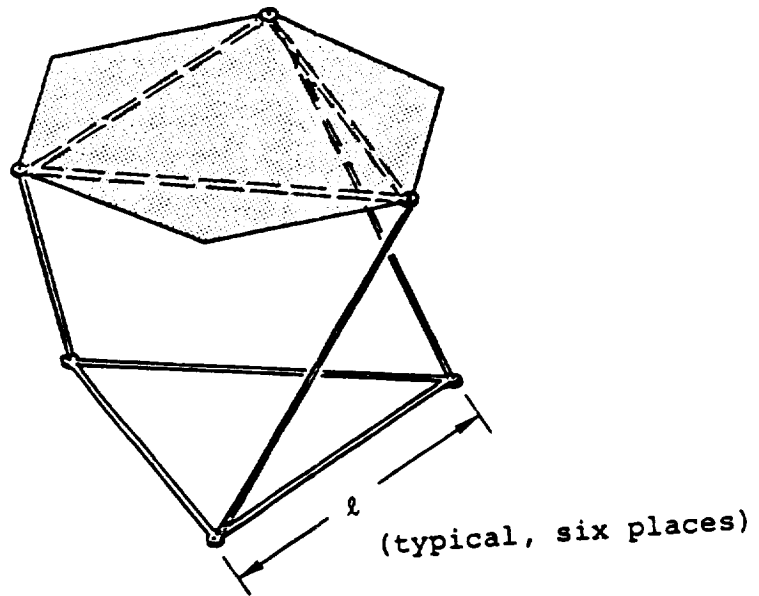
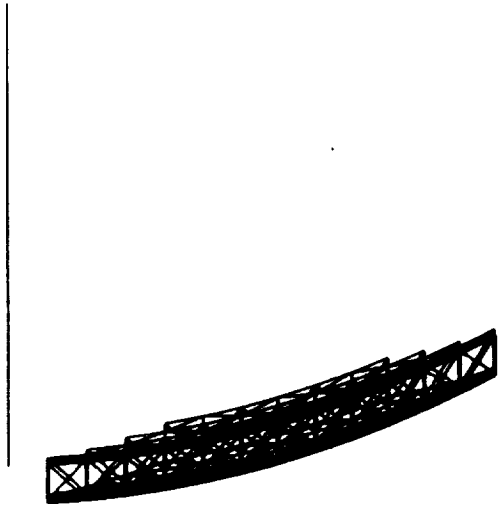
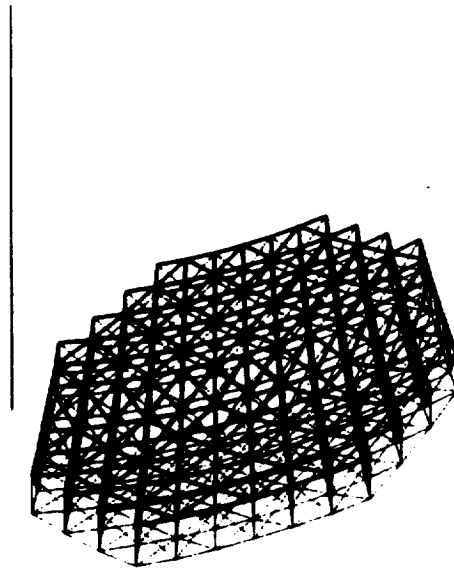

Figure 13. The basic truss module.



Elevation View



Perspective View

Figure 14. Views of Pactruss for offset paraboloid.

SECTION 4

PANEL DESIGN

In the fabrication of panels for large precise antenna reflectors, a mandrel is needed for laying up the panels. The mandrel would either be as large as the radius of the paraboloid, or made in several pieces. In either case, the expense of the mandrel will be large.

One way to reduce cost is to make only a few mandrels (one, if possible) and replicate panels off of each, using them in the best way to minimize the shape error. The following analysis is aimed at finding the best single mandrel shape to produce identical panels which, when mounted on the support truss at the optimum orientation and position relative to the exact paraboloidal surface.

Consider a paraboloid with focal length F , with its axis along the z axis and its vertex at the origin. Its equation is

$$z = \frac{r^2}{4F}$$

where

$$r = \sqrt{x^2 + y^2}$$

Let a be the offset of the center of the aperture from the axis of the paraboloid and D be the diameter of the aperture. Let ρ and ω be polar coordinates based on the center of the aperture so that inside the aperture, $\rho < D/2$, and ω is measured from the direction of the offset. Then

$$r = \sqrt{a^2 + \rho^2 + 2a\rho \cos \omega}$$

Consider a circular panel whose center is located at the location (r_0, z_0) on the paraboloid. Let ξ, η, ζ be a right-hand coordinate system, with ξ and η tangent to the paraboloidal surface and ζ normal to it. Let ξ point in the meridional direction at the panel center.

Let the xz plane pass through the center of the panel. Then

$$x = r_0 + \xi \cos \phi_0 - \zeta \sin \phi_0$$

$$y = \eta$$

$$z = z_0 + \xi \sin \phi_0 + \zeta \cos \phi_0$$

where

$$\begin{aligned} \tan \phi_0 &= \left. \frac{dz}{dr} \right|_{r=r_0} \\ &= \frac{r_0}{2F} \end{aligned}$$

Substituting x, y, and z into the equation of the paraboloid and solving for ζ gives

$$\zeta = \zeta^*$$

where

$$\zeta^* = \frac{\xi^2 \cos \phi_0 + \eta^2}{\frac{2F}{\cos \phi_0} + \xi \rho \sin \phi_0 \cos \phi_0 + \sqrt{\frac{4F^2}{\cos^2 \phi_0} + 4F\xi \sin \phi_0 - \eta^2 \sin^2 \phi_0}}$$

Let the panel have curvatures in the meridional and circumferential directions of k_m and k_c , respectively. Also let the center displacement of the panel in the ζ direction be ζ_0 and the tilt in the meridional plane be α . The equation of the panel surface is then

$$\zeta = \zeta_p + \zeta_0 + \alpha \xi$$

where

$$\zeta_p = \frac{1}{2}(k_m \xi^2 + k_c \eta^2)$$

Then the local error in the normal direction between the panel and the paraboloidal surface is

$$\delta = \zeta_p - \zeta^* + \zeta_0 + \alpha \xi$$

The mean-squared error is given by

$$\delta_{rms}^2 = \frac{\int_A \left[\zeta^* - \zeta_p - \zeta_0 - \alpha \xi \right]^2 d\xi d\eta}{\int_A d\xi d\eta}$$

where the integrations are carried out over the area of the panel. The mean-squared error is minimized when

$$\zeta_0 = \frac{\int_A \left[\zeta^* - \zeta_p \right] d\xi d\eta}{\int_A d\xi d\eta}$$

$$\alpha = \frac{\int_A \left[\zeta^* - \zeta_p \right] \xi d\xi d\eta}{\int_A d\xi d\eta}$$

This process yields the rms error for a particular value of r . The mean-square error for the entire antenna is obtained by averaging δ_{rms} over the aperture.

The computer code UNIPANL.C, which is included in Appendix A, was written to perform the indicated integrations and averages, and determine the rms error for the antenna. The program is interactive, requesting inputs for D , F , and offset, then repeatedly asking for the panel size and ratio of circumferential to meridional curvature. The integrations are performed numerically with five intervals in the radius and 15 degree intervals around the circumference. The panel curvature that gives the least rms error over the entire aperture is found by a stepping type of search for the minimum.

Some results for panels which have the same curvature in both directions (spherical mandrel) are shown in Figure 15. Note that using an offset feed with an F/D of 1.5 yields almost the same results for inaccuracy as those for a centered-feed antenna with $F/D = 1.0$. To understand these results, consider a 20-meter diameter to be used at a frequency of 100 GHz and require $\lambda/100$ accuracy. Then $\delta_{rms}/D = 1.5 \times 10^{-6}$. With a centered-feed and $F/D = 1.5$, the

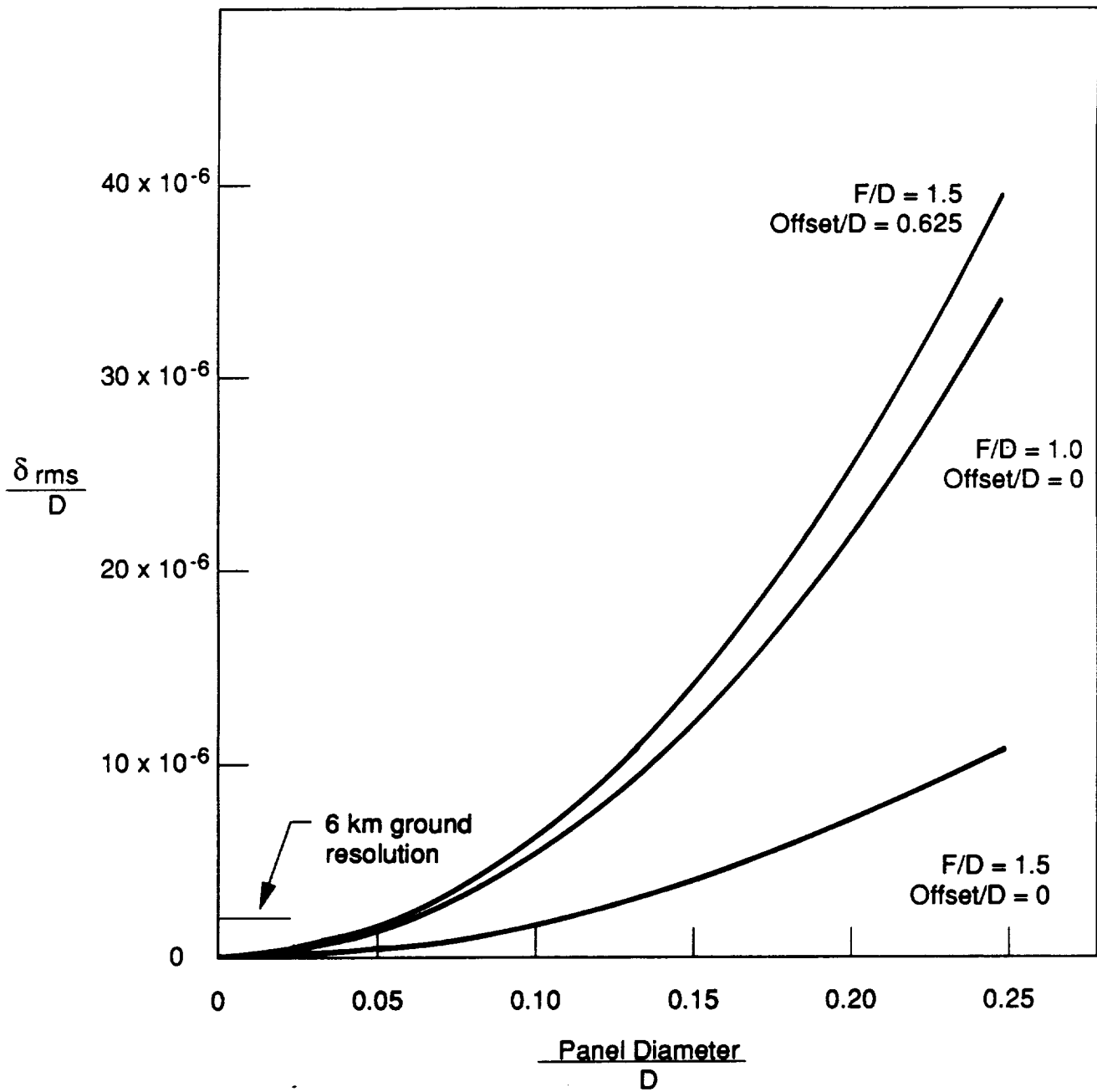

Figure 15. Antenna surface error caused by identical spherical panels.

panel size could be as large as 2 meters. For an offset feed and F/D of 1.5, the allowable panel size is only 1 meter. Note also that a resolution of 6 km for the ESGP radiometer would need a value of δ/D of about 1.3×10^{-6} . For the offset feed case, there would be about 20 panels needed across the aperture diameter.

Incidentally, some trials with the circumferential curvature slightly higher than the meridional indicates significant reduction in the error. Also, providing two mandrels would help a great deal.

SECTION 5

VARIABLE GEOMETRY

One approach to avoiding pattern deterioration when scanning would be to adjust the shape of the reflector as the scanning occurs. In order to determine the magnitude of the motions required of the surface, an analysis was made of the path-length error due to scanning. The approach used was to find the tilted paraboloid for which the mean-square normal distance from the original paraboloid was a minimum. This analysis is coded in the program ADJUST.C included in the appendix.

A sample of the output of ADJUST is included in Table 1. The case treated is a 20-meter-diameter offset-feed antenna with an $F/D = 1.5$ and an offset of 12.5 meters. The rms value of the correction is about 1.5 cm and the maximum value is about 5 cm. These are sizable motions, but not nearly as large as would occur if the beam were steered by rotating the entire antenna.

The indicated surface adjustment would be accomplished by actuators. If the surface were a continuous one, say an electrostatically controlled membrane, then the surface would tend to fair the shape between control points. If the surface is made up of segmented panels, then the control would be applied at the attachment points. Since the panels would each be shaped to conform to the untilted paraboloid, they would exhibit some unavoidable residual error when trying to fit the scanned paraboloid. The program ADJUST includes the ability to examine individual panels for their residual errors. Results for the worst-case panels are shown in Figure 16. Examination shows that the residual errors are similar to those due to using identical panels.

The foregoing results are calculated for scanning by simple feed motion. Much smaller errors will result from the more advanced scanning techniques that will be used. If variable geometry is used, the motions and residual errors would be accordingly smaller.

TABLE 1: REFLECTOR CORRECTIONS FOR SCAN

F = 30.000000 D = 20.000000 r0 = 12.500000 delta = 8.000000 psi = 0.000000
 Displacement of focal point = -3.916113, 0.000000, -1.946797
 Rms path length error = 0.027682
 New focal length = 27.796289 Rms correction = 0.015121

	0.2	0.4	0.6	0.8	1.0
0	-1.481e-003	-6.442e-003	-1.562e-002	-2.967e-002	-4.924e-002
15	-1.307e-003	-5.733e-003	-1.400e-002	-2.677e-002	-4.466e-002
30	-8.270e-004	-3.783e-003	-9.546e-003	-1.875e-002	-3.198e-002
45	-1.670e-004	-1.080e-003	-3.332e-003	-7.486e-003	-1.407e-002
60	5.027e-004	1.701e-003	3.140e-003	4.380e-003	5.004e-003
75	1.009e-003	3.867e-003	8.314e-003	1.409e-002	2.095e-002
90	1.223e-003	4.888e-003	1.098e-002	1.946e-002	3.030e-002
105	1.093e-003	4.538e-003	1.057e-002	1.943e-002	3.131e-002
120	6.600e-004	2.957e-003	7.369e-003	1.437e-002	2.442e-002
135	4.544e-005	6.180e-004	2.386e-003	6.028e-003	1.223e-002
150	-5.790e-004	-1.801e-003	-2.867e-003	-2.950e-003	-1.202e-002
165	-1.040e-003	-3.602e-003	-6.814e-003	-9.766e-003	-1.151e-002
180	-1.209e-003	-4.266e-003	-8.276e-003	-1.230e-002	-1.536e-002
195	-1.040e-003	-3.602e-003	-6.814e-003	-9.766e-003	-1.151e-002
210	-5.790e-004	-1.801e-003	-2.867e-003	-2.950e-003	-1.202e-002
225	4.544e-005	6.180e-004	2.386e-003	6.028e-003	1.223e-002
240	6.600e-004	2.957e-003	7.369e-003	1.437e-002	2.442e-002
255	1.093e-003	4.538e-003	1.057e-002	1.943e-002	3.131e-002
270	1.223e-003	4.888e-003	1.098e-002	1.946e-002	3.030e-002
285	1.009e-003	3.867e-003	8.314e-003	1.409e-002	2.095e-002
300	5.027e-004	1.701e-003	3.140e-003	4.380e-003	5.004e-003
315	-1.670e-004	-1.080e-003	-3.332e-003	-7.486e-003	-1.407e-002
330	-8.270e-004	-3.783e-003	-9.546e-003	-1.875e-002	-3.198e-002
345	-1.307e-003	-5.733e-003	-1.400e-002	-2.677e-002	-4.466e-002

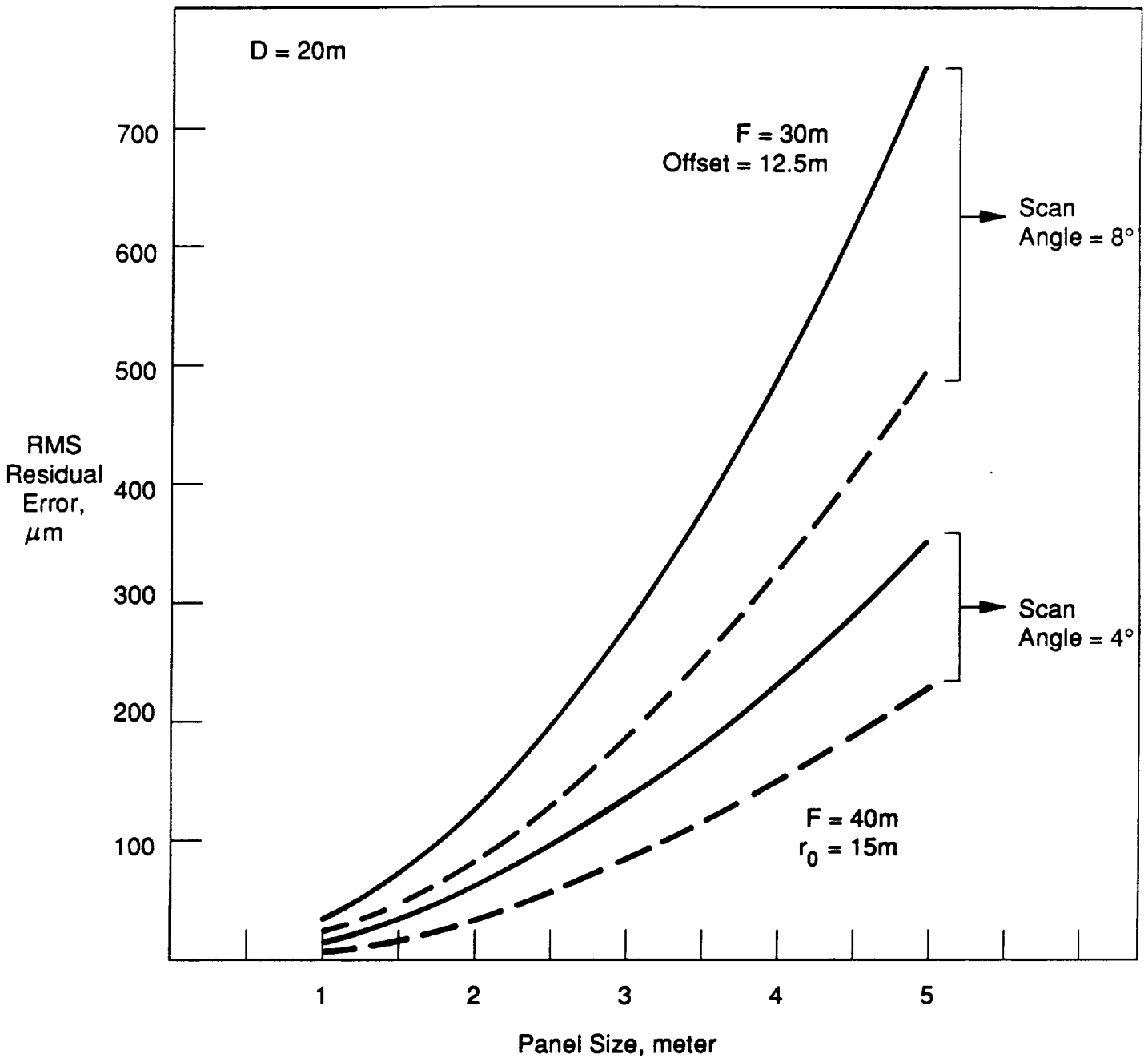

Figure 16. Worst case residual errors after best adjustment of panel.

SECTION 6
CONCLUDING REMARKS

The study reported herein is only a beginning. There remains a great deal of investigation before a good configuration can be selected for development. Among the questions are:

- What rms accuracy is needed by the radiometry mission? $\lambda/30$? $\lambda/50$? $\lambda/100$?
- How good can electronic scanning be? Feed-motion scanning becomes unacceptable at 10 beamwidths. The mission needs 1,000.
- Can robots or intelligent canisters be developed in time to be available for remote assembly of antennas needed in the year 2000?
- Can long-time microstrain stability for the available materials be assured?
- What are the magnitude and distribution of the forces required to adjust the shape of continuous reflecting surfaces?
- How accurately can large continuous shells be built?

The future is promising.

REFERENCES

1. Hedgepeth, John M., and Louis R. Adams, "Design Concepts for Large Reflector Antenna Structures," NASA CR-3663, prepared under Contract No. NAS1-16134 for the National Aeronautics and Space Administration, Langley Research Center, Hampton, Virginia. Astro Research Corporation, Carpinteria, California, January 1983.
2. Hedgepeth, John M., and Karl Knapp, "Effects of Phase Errors on Antenna Performance," ARC-TN-1079, Astro Research Corporation, July 1980.
3. Bernasconi, M.C., and G.G. Reibaldi, "Inflatable, Space-Rigidized Structures: Overview of Applications and Their Technology Impact," preprint IAF 85-210, 36th Congress of the International Astronautical Federation, Stockholm, Sweden, October 1985.
4. Bernasconi, M.C., and G.G. Reibaldi, "Large Inflatable Space-Rigidized Antenna Reflectors," International Astronautical Federation, Paper IAF-87-315, 38th IAF Congress, Brighton, United Kingdom, October 1987.
5. Thompson Ramo Wooldridge, Inc., "Sunflower Solar Collector," NASA CR-46, prepared under Contract No. NAS5-462 for the National Aeronautics and Space Administration, Washington, D.C., May 1964.
6. Ard, K.E., "Design and Technology Study for Extreme Precision Antenna Structures," NASA CR-174861, prepared under Contract No. NAS3-23249 for the National Aeronautics and Space Administration, Lewis Research Center, Cleveland, Ohio. Harris Corporation, Government Aerospace Systems Division, Melbourne, Florida, August 1985.
7. Hedgepeth, John M., "Critical Requirements for the Design of Large Space Structures," NASA CR-3484, prepared under Contract No. NAS1-15347 for the National Aeronautics and Space Administration, Langley Research Center, Hampton, Virginia. Astro Research Corporation, Carpinteria, California, November 1981.
8. Hedgepeth, John M., "Influence of Fabrication Tolerances on the Surface Accuracy of Large Antenna Structures," AIAA Journal, vol. 20, No. 5, pp. 680-686, May 1982.
9. Hedgepeth, John M., "Accuracy Potentials for Large Space Antenna Reflectors with Passive Structure," J. Spacecraft and rockets, vol. 19, No. 3, pp. 211-217, May-June 1982.
10. Hedgepeth, John M., "Support Structures for Large Infrared Telescopes," NASA CR 3800, prepared under Contract No. NAS1-16923 for the National Aeronautics and Space Administration, Langley Research Center, Hampton, Virginia. Astro Research Corporation, Carpinteria, California, July 1984.
11. Hedgepeth, John M., "Pactruss Support Structure for Precision Segmented Reflectors: Final Report," AAC-TN-1153, Astro Aerospace Corporation, Carpinteria, California, NASA CR-181747, June 1989.

Appendix A

```

/* SCITECH.H - Header file for all science,engineering, and technical
 *           programs. This "include"s all the needed headers.
 *           J. M. Hedgepeth           7/31/86
 *
 *           Added string.h and process.h to list.           jmh           12/30/86
 *           Added float.h.                                 jmh           2/10/87
 *           Added io.h                                     jmh           9/4/87
 *           Added macro for flushcon() and constants       jmh           11/23/88
 *
 */

```

```

#include <stdio.h>
#include <conio.h>
#include <io.h>
#include <ctype.h>
#include <dos.h>
#include <malloc.h>
#include <math.h>
#include <float.h>
#include <errno.h>
#include <stdlib.h>
#include <string.h>
#include <time.h>
#include <scieng.h>
#include <fcntl.h>
#include <process.h>

```

```

/* Force use of functions, not macros
 */
#undef toupper
#undef tolower

```

```

/*****
 */

```

```

#define flushcon() while(kbhit()) getch()

```

```

/* Values of particular mathematical constants
 */

```

```

#define PI           3.14159265358979
#define EULER       0.577215664901532
#define EBASE       2.718281828459045

```

```

/*****
 */

```

Date of file: 11/10/88

Printed on: 01/09/89

```

/* UNIPANL.C - Determine errors in surface shape if a paraboloid is approximated
 *           by panels of uniform meridional and circumferential curvature.
 *
 *
 *
 *
 *
 *
 *
 */

```

J. M. Hedgepeth 11/9/88

```

#include <scitech.h>
#define flushcon() while(kbhit()) getch()

double F,r0,D,curv,ratio,d_panl;
char line[80];

/*
 *           F           Focal length of base paraboloid
 *           r0          Distance from paraboloid axis to aperture center
 *           D           Aperture diameter
 *           curv        Meridional panel curvature
 *           ratio        Ratio of panel circumferential to meridional curvature
 *           d_panl      Panel diameter
 *
 */

double degtorad;

double findmin(double []),getsumsq(double, double []), panel_err(double, double);

main()
{
    int i,j,k;
    double xv,yv,zv,xf,yf,zf,temp0,temp1,temp2,rms,path,*ptr;
    static double eps[120];
    char chr;

    degtorad = (double)PI/180.;
    setmode(fileno(stdprn),O_TEXT);

    while(1) {
        printf("\n\nEnter the reflector focal length, aperture diameter,\n"
            "and distance to aperture center.\n? ");
        gets(line);
        for(i=0; i<80 && line[i]; i++)
            if(line[i] == ',')
                line[i] = ' ';

        if(sscanf(line," %lf %lf %lf", &F, &D, &r0) == 3)
            break;
        printf("\n\007Incorrect entry.");
    }

    while(1) {
        while(1) {
            printf("\n\nEnter panel diameter and ratio of circumferential to "

```

"meridional curvatures." " ";

```
gets(line);
for(i=0; i<80 && line[i]; i++)
    if(line[i] == ',')
        line[i] = ' ';

if(sscanf(line, "%lf %lf", &d_panl, &ratio) == 2)
    break;
printf("\n\007Incorrect entry.");
}

rms = findmin(eps);

printf("\n\n          REFLECTOR ACCURACY FOR PANELS WITH UNIFORM "
        "CURVATURE\n\n");
printf("F = %lf  D = %lf  r0 = %lf  d = %lf  ratio = %lf\n",
        F,D,r0,d_panl,ratio);
printf("Meridional curvature for minimum rms surface error = %lf\n",
        curv);
printf("Rms surface error of reflector = %14.3le\n\n",rms);
printf("Press any key to continue?  ");
flushcon();
getch();
printf("\n          0.1          0.3          0.5          "
        "0.7          0.9");

for(i=0; i<13; i++) {
    printf("\n %3d ",i*15);
    for(j=0; j<5; j++)
        printf("%14.3le",eps[5*i + j]);
}

printf("\nDo you want to print the results? <N>  ");
if(toupper(getche()) == 'Y') {
    fprintf(stdprn, "\n\n\n\n          REFLECTOR ACCURACY FOR "
        "PANELS WITH UNIFORM CURVATURE\n\n");
    fprintf(stdprn, "F = %lf  D = %lf  r0 = %lf  d = %lf  ratio = %lf"
        "\n",F,D,r0,d_panl,ratio);
    fprintf(stdprn, "Meridional curvature for minimum rms surface error "
        "= %lf\n",curv);
    fprintf(stdprn, "Rms surface error of reflector = %14.3le\n\n", rms);
    fprintf(stdprn, "          0.1          0.3          0.5"
        "          0.7          0.9");

    for(i=0; i<13; i++) {
        fprintf(stdprn, "\n %3d ",i*15);
        for(j=0; j<5; j++)
            fprintf(stdprn, "%14.3le",eps[5*i + j]);
    }
    fprintf(stdprn, "\n\n");
    fflush(stdprn);
    fflush(stdin);
}

printf("\n\nDo you want to examine new panel parameters? <N>  ");
flushcon();
if(toupper(getche()) != 'Y')
    break;
}
putchar('\n');
```

```
void flushcon(
{
    while(kbhit())
        getch();
}

/*****
*/
```

```

Izsq = Iz = Izksi = Iksisq = I = 0;
phi = atan(r/2., F);
cosphi = cos(phi);
sinphi = sin(phi);

for(i=0; i<12; i++) {
    omega = ((double)i + 0.5)*15.*degtorad;
    cosom = cos(omega);
    sinom = sin(omega);
    for(j=0; j<5; j++) {
        rho = d_panl*(2*j + 1)/20.;
        ksi = rho*cosom;
        eta = rho*sinom;
        B = 2.*F/cosphi + ksi*sinphi*cosphi;
        C = ksi*ksi*cosphi*cosphi + eta*eta;
        zeta = C/(B + sqrt(B*B - C*sinphi*sinphi));
        zeta -= kx*(ksi*ksi + ratio*eta*eta)/2.;
        eps[i][j] = zeta;
        I += rho;
        Iz += rho*zeta;
        Izsq += rho*zeta*zeta;
        Izksi += rho*zeta*ksi;
        Iksisq += rho*ksi*ksi;
    }
}
dave = Iz/I;
sx = Izksi/I;
rms = sqrt(Izsq/I - dave*dave -sx*sx*Iksisq/I);

if(kbhit()) {
    printf("\n\n          PANEL ERRORS\n\n");
    printf("F = %lf  D = %lf  r0 = %lf  d = %lf  ratio = %lf\n\n",
          F,D,r0,d_panl,ratio);
    printf("Meridional curvature = %lf  Panel location = %lf\n\n", kx, r);
    printf("Rms surface error of panel = %14.3le\n",rms);
    printf("\n          0.1          0.3          0.5          "
          "0.7          0.9\n");

    for(i=0; i<12; i++) {
        omega = ((double)i + 0.5)*15.;
        printf("\n%6.1lf",omega);
        omega *= degtorad;
        cosom = cos(omega);
        for(j=0; j<5; j++) {
            rho = d_panl*(2*j + 1)/20.;
            ksi = rho*cosom;
            zeta = eps[i][j] - dave -sx*ksi;
            printf("%14.3le",zeta);
        }
    }
    printf("\n\nPress any key to continue...");
    flushcon();
    getch();
}

return rms;
}

```

/*****

```

*****
*/

double findmin(double eps[])
{
    int n;
    double temp,interval,sumsq;

    curv = 0.5/F;
    sumsq = getsumsq(curv,eps);
    interval = -0.01/F;

    for(n=0; n<10; n++) {
        printf("\nCycle %2d  Interval = %lf\nCurvature, rms = %lf, %lf",
                n,interval,curv,sqrt(sumsq));
        while((temp = getsumsq(curv + interval,eps)) <= sumsq) {
            curv += interval;
            sumsq = temp;
            printf("    %lf, %lf",curv,sqrt(temp));
        }
        interval /= -2.;
    }
    return sqrt(sumsq);
}

/*****
*/

double getsumsq(double cur, double eps[])
{
    int i,j,k;
    double temp,sum,omeg,cosom,r,factor;
    static double weight[] = { 0.1, 0.3, 0.5, 0.7, 0.9};

    for(i=0,sum=0; i<13; i++) {
        factor = 1.;
        if(i == 0 || i == 12)
            factor = 0.5;
        omeq = i*15.*degtorad;
        cosom = cos(omeq);
        for(j=0; j<5; j++) {
            temp = (2*j + 1)*D/20.;
            r = sqrt(r0*r0 + 2.*temp*r0*cosom + temp*temp);
            k = 5*i + j;
            eps[k] = panel_err(cur,r);
            sum += factor*weight[j]*eps[k]*eps[k];
        }
    }
    return sum/30;
}

/*****
*/

double panel_err(double kx, double r)
{
    int i,j,k,lp[3];
    double B,C,ksi,eta,zeta,rho,omega,dave,sx,rms,Izsq,Iz,Izksi,I,Iksisq,phi;
    double cosom,sinom,cosphi,sinphi;
    static double eps[12][5];

```

Date of file: 10/ 9/88

Printed on: 01/09/89

```

/* ADJUST.C - Determine correct paraboloid for scanned beam and correction
 *           distances normal to unscanned paraboloid.
 *
 *
 *
 *
 *           J. M. Hedgepeth 9/19/88
 *
 *   Added minimization of sum-displacements-squared with
 *           respect to F.           9/27/88
 *   Added examination of residual errors for panels.   9/29/88
 *   Changed to best-fit panel motion.                   9/30/88
 */

```

```
#include <scitech.h>
```

```
double F,Fnew,delta,psi,r0,D,a,b,c;
char line[80];
```

```

/*
 *   F           Focal length of base paraboloid
 *   Fnew        Focal length of scanned paraboloid
 *   delta       Angle of scan in degrees
 *   psi         Azimuth of scan in degrees
 *   r0          Distance from paraboloid axis to aperture center
 *   D           Aperture diameter
 *   a, b, c    Parameters of scanned paraboloid
 *
 */

```

```
double cosdel,sindel,cospsi,sinpsi,degtorad;
```

```
double normdist(double, double),findmin(double []),getsumsq(double, double []);
double minpath(double, double, double);
void panel_err(double []);
```

```
main()
```

```

{
    int i,j,k;
    double xv,yv,zv,xf,yf,zf,temp0,temp1,temp2,rms,path,*ptr;
    static double eps[120];
    char chr;

    degtorad = (double)PI/180.;
    setmode(fileno(stdprn),O_TEXT);

    while(1) {
        printf("\n\nEnter the reflector focal length, aperture diameter,\n"
            "and distance to aperture center.\n? ");
        gets(line);
        for(i=0; i<80 && line[i]; i++)
            if(line[i] == ',')
                line[i] = ' ';

        if(sscanf(line," %lf %lf %lf", &F, &D, &r0) == 3)
            break;
    }
}

```

```

printf("\n\007Incorrect entry.");

while(1) {
    while(1) {
        printf("\n\nEnter scan angle and azimuth in degrees.\n? ");

        gets(line);
        for(i=0; i<80 && line[i]; i++)
            if(line[i] == ',')
                line[i] = ' ';

        if(sscanf(line, "%lf %lf", &delta, &psi) == 2)
            break;
        printf("\n\007Incorrect entry.");
    }

    cosdel = cos(degtorad*delta);
    sindel = sin(degtorad*delta);
    cospsi = cos(degtorad*psi);
    sinpsi = sin(degtorad*psi);

    rms = findmin(eps);

    xv = r0 - a*cospsi*cosdel - b*sinpsi - c*cospsi*sindel/Fnew;
    yv = -a*sinpsi*cosdel + b*cospsi - c*sinpsi*sindel/Fnew;
    zv = r0*r0/4./F + a*sindel - c*cosdel/Fnew;

    xf = xv + Fnew*cospsi*sindel;
    yf = yv + Fnew*sinpsi*sindel;
    zf = zv + Fnew*cosdel - F;

    path = minpath(xf, yf, zf + F);

    printf("\n\n          REFLECTOR CORRECTIONS FOR SCAN\n\n");
    printf("F = %lf  D = %lf  r0 = %lf  delta = %lf  psi = %lf\n",
           F,D,r0,delta,psi);
    printf("Displacement of focal point = %lf, %lf, %lf\n",xf,yf,zf);
    printf("Rms path length error = %lf\n",path);
    printf("New focal length = %lf  Rms correction = %lf\n\n",Fnew,rms);
    printf("Press any key to continue? ");
    getch();
    printf("\n          0.2          0.4          0.6          "
           "\n          "0.8          1.0");

    for(i=0; i<24; i++) {
        printf("\n %3d ",i*15);
        for(j=0; j<5; j++)
            printf("%14.3le",eps[5*i + j]);
    }

    printf("\nDo you want to print the results? <N> ");
    if(toupper(getche()) == 'Y') {
        fprintf(stdprn, "\n\n\n\n          REFLECTOR CORRECTIONS FOR"
                    "\n          " SCAN\n\n");
        fprintf(stdprn, "F = %lf  D = %lf  r0 = %lf  delta = %lf  psi = %lf"
                    "\n",F,D,r0,delta,psi);
        fprintf(stdprn, "Displacement of focal point = %lf, %lf, %lf\n",
                    xf,yf,zf);

        fprintf(stdprn, "Rms path length error = %lf\n",path);
        fprintf(stdprn, "New focal length = %lf  Rms correction = %lf\n\n",
                    Fnew,rms);
    }
}

```

```

    fprintf(stdprn,"          0.2          0.1          0.6"
           "          "          0.8          1.0");
    for(i=0; i<24; i++) {
        fprintf(stdprn,"    \n %3d  ",i*15);
        for(j=0; j<5; j++)
            fprintf(stdprn,"%14.3le",eps[5*i + j]);
    }
    fprintf(stdprn,"    \n\n");
    fflush(stdprn);
}

printf("\n\nDo you want to examine individual panels? <N> ");
if(toupper(getche()) == 'Y')
    panel_err(eps);

while(i) {
    printf("\n\nEnter 'F'  to change focal length, (%10.3lf)"
           "\n      'D'  to change diameter,    (%10.3lf)"
           "\n      'O'  to change offset,      (%10.3lf)"
           "\n      'q'  to quit,"
           "\n      <CR> to continue."
           "\n? ",F,D,r0);
    if((chr = toupper(getche())) == 'Q')
        exit(0);
    if(chr == 'F' || chr == 'D' || chr == 'O') {
        printf("\n\nEnter new value? ");
        gets(line);
        if(sscanf(line," %lf",&temp2) == 1) {
            if(chr == 'F')
                F = temp2;
            if(chr == 'D')
                D = temp2;
            if(chr == 'O')
                r0 = temp2;
        }
    }
    else if(chr == '\r')
        i = 0;
    else
        putchar('\007');
}
}
}

```

```

/*****
*/

```

```

double normdist(double x, double y)
{
    double r,theta,dif,cosdif,sindif,cosphi,sinphi;
    double alfa1,alfa2,alfa3,betal,beta2,beta3,A,B,C,temp0,temp1;

    r = sqrt(x*x + y*y);
    theta = atan2(y,x);

    dif = psi*degtorad - theta;
    sindif = sin(dif);
    cosdif = cos(dif);

    cosphi = cos(atan(r/2./F));
}

```

```

sinphi = cosphi*r 2./F;

alfal = cosdif*cosdel*sinphi + sindel*cosphi;
alfa2 = sindif*sinphi;
alfa3 = cosdif*sindel*sinphi - cosdel*cosphi;

betal = a/F + (cosdif*r - cospsi*r0)*cosdel/F
        - (r*r - r0*r0)*sindel/4./F/F;
beta2 = b/F + (sindif*r - sinpsi*r0)/F;
beta3 = c/F/Fnew + (cosdif*r - cospsi*r0)*sindel/F
        + (r*r - r0*r0)*cosdel/4./F/F;

A = alfa1*alfal + alfa2*alfa2;
B = -F*(alfal*betal + alfa2*beta2) + 2.*Fnew*alfa3;
C = F*F*(betal*betal + beta2*beta2) - 4.*F*Fnew*beta3;

temp0 = B*B - A*C;
if(temp0 < 0)
    return 1.0e99;
temp0 = sqrt(temp0);

if(B > 0)
    return ((-B + temp0)/A);
else
    return ((-B - temp0)/A);
}

```

```

/*****
*/

```

```

double findmin(double eps[])
{
    int n;
    double ratio,temp,interval,sumsq;

    ratio = 1.;
    sumsq = getsumsq(ratio,eps);
    interval = 0.01;

    for(n=0; n<10; n++) {
        printf("\nCycle %d ",n);
        while((temp = getsumsq(ratio + interval,eps)) <= sumsq) {
            ratio += interval;
            sumsq = temp;
        }
        interval /= -2.;
    }
    Fnew = ratio*F;
    return sqrt(sumsq);
}

```

```

/*****
*/

```

```

double getsumsq(double ratio, double eps[])
{
    int i,j,k;
    double temp0,temp1,sum,omeg,cosom,sinom,x,y,r,theta;
    static double weight[] = { 1.0, 2.0, 3.0, 4.0, 2.5};

```

```

Fnew = ratio*F;

temp0 = r0/2./F;

a = 2.*Fnew*(sindel + temp0*cospsi*cosdel)/(cosdel - temp0*cospsi*sindel);
b = 2.*Fnew*temp0*sinpsi/(cosdel - temp0*cospsi*sindel);
c = (a*a + b*b)/4.;

for(i=0,sum=0; i<24; i++) {
    omeg = i*15.*degtorad;
    cosom = cos(omeg);
    sinom = sin(omeg);
    for(j=0; j<5; j++) {
        templ = (j + 1)*D/10.;
        x = r0 + templ*cosom;
        y = templ*sinom;
        k = 5*i + j;
        eps[k] = normdist(x,y);
        sum += weight[j]*eps[k]*eps[k];
    }
}
return sum/300.;
}

```

```

/*****
*/

```

```

void panel_err(double eps[])
{

```

```

    int i,j,k,lp[3];
    double x,y,r,x0,y0,rho,omega,temp0,dave,sx,sy,rms;
    static double weight[] = { 1.0, 2.0, 3.0, 4.0, 2.5};
    double Mat[12];

    while(1) {
        while(2) {
            printf("\nEnter coordinates (x0, y0) of panel center... ? ");
            gets(line);
            for(i=0; i<80 && line[i]; i++)
                if(line[i] == ',')
                    line[i] = ' ';
            if(sscanf(line," %lf %lf", &x0,&y0) == 2)
                break;
            else
                putchar('\007');
        }
        while(2) {-
            printf("\nEnter size (diameter) of panel... ? ");
            gets(line);
            if(sscanf(line," %lf", &r) == 1)
                break;
            else
                putchar('\007');
        }
        r /= 2.;
        for(i=0; i<12; i++)
            Mat[i] = 0;

        for(i=0,rms = 0; i<12; i++) {
            omega = (double)i*30.*degtorad;

```



```

*****
*/

double minpath(double xf, double yf, double zf)
{
    int i,j,k;
    double sum,sumsq,x,y,z,r,rho,omega,theta,length,weight,denom,Z;

    denom = 0;
    sum = 0;
    sumsq = 0;
    for(i = 0; i<24; i++) {
        omega = i*15*degtorad;
        for(j=0; j<5; j++) {
            rho = (j + 1)*D/10.;
            x = r0 + rho*cos(omega);
            y = rho*sin(omega);
            r = sqrt(x*x + y*y);
            z = r*r/(4.*F);
            theta = atan2(y,x);

            x -= xf;
            y -= yf;
            length = -zf - z*cosdel - r*cos(theta - psi*degtorad)*sindel +
                sqrt(x*x + y*y + (z - zf)*(z - zf));

            weight = j + 1;
            if(j == 4)
                weight /= 2.;

            denom += weight;
            sum += weight*length;
            sumsq += weight*length*length;
        }
    }
    Z = sum/denom;
    sumsq /= denom;
    sumsq -= Z*Z;
    return sqrt(sumsq);
}

*****
*/

```



Report Documentation Page

1. Report No. NASA CR-182065		2. Government Accession No.		3. Recipient's Catalog No.	
4. Title and Subtitle Structures for Remotely Deployable Precision Antennas			5. Report Date January 1989		
			6. Performing Organization Code		
7. Author(s) John M. Hedgepeth			8. Performing Organization Report No. AAC-TN-1154		
			10. Work Unit No. 506-43-41-02		
9. Performing Organization Name and Address Astro Aerospace Corporation 6384 Via Real Carpinteria, CA 93013-2993			11. Contract or Grant No. NAS1-18567 (Task 4)		
			13. Type of Report and Period Covered Contractor Report		
12. Sponsoring Agency Name and Address NASA Langley Research Center Hampton, VA 23665-5225			14. Sponsoring Agency Code		
			15. Supplementary Notes Langley Technical Monitor: W. B. Fichter Final Report - Task 4		
16. Abstract <p>There is a need for completely deployable large antenna reflectors capable of efficiently handling millimeter-wave electromagnetic radiation. The emphasis in this paper is on the structural concepts and technologies that are appropriate to fully automated deployment of dish-type antennas with solid reflector surfaces. First, the structural requirements are discussed. Then, existing concepts for fully deployable antennas are described and assessed relative to the requirements. Finally, several analyses are presented that evaluate the effects of beam steering and segmented reflector design on the accuracy of the antenna.</p>					
17. Key Words (Suggested by Author(s)) Deployable Antennas Microwave Radiometers Surface Accuracy Earth Observation			18. Distribution Statement Unclassified - Unlimited Subject Category: 18		
19. Security Classif. (of this report) Unclassified		20. Security Classif. (of this page) Unclassified		21. No. of pages 57	22. Price A04

