

The George W. Woodruff
School of Mechanical Engineering



Georgia Institute
of Technology

Atlanta, Georgia 30332

ORIGINAL PAGE IS
OF POOR QUALITY



GEORGIA TECH 1885-1985

DESIGNING TOMORROW TODAY

THE GEORGE W. WOODRUFF SCHOOL OF
MECHANICAL ENGINEERING

M E 4182

MECHANICAL DESIGN ENGINEERING

NASA/UNIVERSITY

Advanced Missions Space Design Program

SOIL EXPERIMENT

August, 1987

Linton Hutcheson
Todd Butler
Mike Smith
Charles Cline
Steve Scruggs
Nadim Zakhia

Georgia Institute of Technology
Atlanta, Georgia 30332-0405

TABLE OF CONTENTS

	Page Number
I. ABSTRACT	1
II. PROBLEM STATEMENT	3
A. Introduction	3
B. Performance Objectives	4
C. Constraints	4
III. DESIGN DETAILS	7
A. Summary	7
B. Environmental Simulation	8
C. Soil Simulant	16
D. Shear Test	20
E. Penetration Test	28
F. Test Procedure	38
G. Digging Implement Methodology	45
IV. PARTS LIST / COST ANALYSIS	49
V. CONCLUSION	51
VI. RECOMMENDATIONS	53
VII. ACKNOWLEDGEMENTS	54
VIII. BIBLIOGRAPHY	55
IX. APPENDICIES	57

I. ABSTRACT

An experimental procedure was devised to investigate the effects of the lunar environment on the physical properties of simulated lunar soil. The test equipment and materials used consisted of a vacuum chamber, direct shear tester, static penetrometer, and fine grained basalt as the simulant.

The vacuum chamber provides a medium for applying the environmental conditions to the soil experiment with the exception of gravity. The ultra-high vacuum will simulate the essentially zero atmospheric pressure which exists on the moon. The vacuum will also allow for the investigation of outgassing and reduction of absorbed gases on soil properties.

The shear strength parameters are determined by the direct shear test. Another means of measuring the shear properties is the triaxial compression test. The direct shear test, however, is the most suitable method for granular materials such as basalt.

Strength parameters and the resistance of soil penetration by static loading will be investigated by the use of a static cone penetrometer. This experiment can be used to determine the soil properties by correlating the actual pressure applied to the penetrometer and the area of the conical tip.

In order to conduct a soil experiment without going to the moon, a suitable lunar simulant must be selected. This simulant must resemble lunar soil in both composition and particle size. The particle size of the simulant is an important criteria to consider due to the manner in which a soil sample may fail. The

selection of the soil simulant for this test procedure was based on the investigation of soil samples taken during missions to the

moon. The soil that most resembles actual lunar soil is basalt. A "recipe" for the simulant was proposed by Bromwell and Carrier Inc.

The soil parameters, as determined by the testing apparatus, will be used as design criteria for lunar soil engagement equipment.

II PROBLEM STATEMENT

A. Introduction

With the present emphasis on space exploration of the celestial bodies in our solar system and in particular the use of the moon as a space station, it is necessary to learn more about the properties of the materials which are expected to be used on these bodies. The success of future lunar missions is dependent upon the correct observation and interpretation of measurements on the lunar surfaces as well as the proper design of vehicles and structures to be placed on the moon. Therefore, it is essential to have a basic knowledge of the mechanical properties of lunar soil.

Because of the extreme differences between the lunar and earth environments, the most important of which is the absence of an atmosphere on the moon, one would not expect that the lunar soil would have the same properties as a similar material on earth. An experimental procedure was devised in order to investigate the effects of lunar environmental conditions on the behavior of the soil simulant which has a high probability of being representative of actual lunar soil and to provide basic engineering data on the properties of the soil to aid in the design and construction of lunar engagement equipment.

Although the test procedure has been largely an investigation of specific properties of a selected soil simulant under prescribed environmental conditions, an important intention throughout the course of designing the

test procedure has been to allow a sufficient margin in determining to what extent the environmental conditions should be simulated so that the data obtained from the experiment will be useful in designing of lunar digging implements.

B. Performance Objectives

The soil experiment will be designed to meet the following performance objectives:

SOIL PARAMETERS

The soil test should yield mechanical properties of a lunar soil simulant. The soil properties which need to be determined are cohesion, internal angle of friction, bulk density, bearing capacity, soil resistance, and porosity. The soil test should yield all of these necessary properties through the utilization of two types of tests, the shear test and the static cone penetration test. These two types of testing procedures shall be conducted on Earth in a manner that is least expensive as possible.

PROJECTION OF RESULTS

The design of a lunar digging implement is beyond the scope of our report; however, a methodology will be proposed describing how our test will produce the necessary results in order to design a lunar digging implement. The methodology will explain how each test result will be applied to certain aspects of the digging implement.

C. Constraints

The environmental characteristics of the moon differ

**ORIGINAL PAGE IS
OF POOR QUALITY**

greatly from those on Earth. These characteristics will affect the testing procedure somewhat.

The environmental conditions on the moon impose the greatest constraints on the testing procedure. The most important of these constraints are as follows: temperature gradient, lack of atmosphere, radiation, and reduced gravitational pull.

TEMPERATURE

The temperature on the moon ranges from -200 degrees Fahrenheit in total darkness to 200 degrees Fahrenheit in the sunlight.

ATMOSPHERE

Since the atmosphere on the moon is about one two-millionth that of the Earth, it is relatively non-existent.

RADIATION

One of the consequences of having no atmosphere is the fact that the moon receives much more radiation upon its surface than the Earth. This radiation induces an electro-static charge on the moon's surface. The moon receives a particle radiation from the sun composed of protons(H^+) and alpha particles(He^{++}). The radiation on the moon's surface is normally around .5 to 1 mrad/hr. During solar flares, however, this increases dramatically to rates up to 7 rad/hr.

GRAVITY

The gravitational acceleration on the surface of the

ORIGINAL PAGE IS
OF POOR QUALITY

moon is 1.623 m/s^2 . This is approximately $1/6$ of the Earth's gravity.

III: DESIGN DETAILS

A. SUMMARY

Since it is desirable to design digging implements which will operate on the moon, it is necessary to test the mechanical properties of lunar soil. It was decided by our design group that the direct shear test and the static cone penetration test would be the best type tests for obtaining the necessary results which are required for the design of a lunar digging implement. Since the properties of the Moon's soil differ greatly from those on the Earth, a great deal of research had to be conducted concerning lunar soil and lunar environment. Also, research had to be conducted concerning the shear tester and static cone penetrometer which are mainly associated with Civil Engineering. The fact that a great deal of our project dealt with Civil Engineering resulted in an extensive amount of time spent in familiarizing ourselves with aspects of Civil Engineering and geology.

B. Environmental Simulation

The environmental conditions of the moon differ greatly from the conditions found on Earth. The determination of the effects of these differences and the method by which they may be simulated are very important in properly designing lunar equipment and in devising lunar soil simulation tests. As previously stated the key conditions to be considered are temperature, gravity, radiation, and the reduced atmosphere.

TEMPERATURE

The temperature on the moon ranges from -200 degrees Fahrenheit in total darkness to 200 degrees Fahrenheit in the sunlight. The extreme temperatures will affect any fluids used for the lubrication of test equipment. Any metal to metal contact would result in cold welding or adhesion of the materials. In order to fully study the effects of temperature on soil properties without narrowing the temperature range due to test equipment limitations, the temperature gradient will be isolated to the soil test sample only.

Under vacuum conditions, research has shown that elevated temperature causes a fairly substantial increase in the stiffness of the soil. Also, it has been shown that the increase in temperature will result in the removal of a greater amount of adsorbed gas under vacuum causing an increase in shear strength. Low temperatures will result in an increase in the shear strength under ultra-high vacuum.

Also it would be expected that a decrease in temperature would result in re-adsorption of gas into the particle surfaces. However, if the adsorbed gas is mostly water, temperatures near the freezing point of water would cause it to become bound more tightly to the surface and interaction between the adsorbed layers on different particles may take place.

In order to simulate the temperature gradient for the shear test and penetration test, a heating and cooling apparatus will be required (see Fig.1 and Fig.2).

The cooling mode will be achieved by flowing liquid nitrogen through the coils of the apparatus. The heating mode is achieved by flowing steam through the coils. The temperature simulation for the penetrometer test will utilize a Whirlpool model xk-1200 heating and cooling unit. The temperature simulation for the shear test will be achieved by modification of the shear box apparatus (see section D).

GRAVITY

Gravity is definitely a prime consideration in the design of any lunar soil engaging equipment. Systems that work well on Earth may not function on the moon. A careful force analysis must be performed on any system used. Attention must be paid to the fact that while a body has the same mass on the moon it only has one sixth of the force holding it down. If too much force must be applied to engage the soil, it may not be found as desired.

ORIGINAL PAGE IS
OF POOR QUALITY

Lack of gravity affects the bulk density of lunar soil. Lunar soil is less dense than a typical Earth soil and has a density ranging from 1.36 g/cm³ to 3.24 g/cm³.

The KC-135 aircraft will enable the effects of a reduced gravitational pull on soil mechanics to be evaluated. The aircraft is flown in a parabolic path from which the reduced gravity is maintained for approximately two minutes. This is ample time to conduct the experiment.

Parallelogram gravity simulators are available which can simulate the force of gravity on mechanical systems. This parallelogram simulator could be used in the development and testing stages in the production of lunar soil engaging equipment.

RADIATION

Radiation needs to be considered in the design of lunar soil engaging equipment. Ultraviolet radiation and charged particle radiation are particularly important in the selection of polymers. This radiation can cause chain scission of organic materials, free radical formation, cross linking of organic materials, and secondary radiation damage. Metals represent no radiation damage problems except at extremely high doses similar to reactor fluxes. They are essentially undamaged by irradiation from natural space sources. In ceramic materials radiation damage is limited to minor surface effects.

A Spectrolab Spectrosun 1-25 Solar simulator which uses a xenon arc discharge could be used to simulate the

ORIGINAL PAGE IS
OF POOR QUALITY

interlocking between the particles would be small. For this reason interparticle forces were considered to contribute the major portion of the shear strength at the higher porosities. When the soil is placed in an ultra-high vacuum environment, adsorbed gas layers were removed permitting a closer proximity of the surfaces resulting in an increase the surface forces.

The environmental factor of primary concern, therefore, is not necessarily the vacuum level in the soil pores but rather the amount of adsorbed gas remaining on the surfaces of the grains. Although the vacuum level in the pores decreased when the soil was heated but increased when the soil cooled, some gas was re-adsorbed on the particle surfaces during cooling. This would account for the fact that while the shear strength is unaffected by ultra-high vacuum at room temperature it appears to increase at these vacuum levels under elevated temperature.

The amount of gas removed and the magnitude of the interparticle forces depends largely on the mineralogical composition of the soil. This removal of adsorbed gas and development of interparticle forces affects the soil properties because the soil is able to maintain a higher porosity under ultra-high vacuum than at lower vacuum. However, the porosity obtained at vacuum levels is less than that obtained in atmosphere. This is due to the removal of frictional air which results in higher impact velocities during deposition. In any given case, the porosity obtained

under ultra-high vacuum may or may not be greater than that obtained in atmosphere since this also depends on the mineralogical composition of the soil. Moreover, noting that the rapid increase in vacuum level may be attributed to the fact that at higher temperature the gas is released from the surfaces of the particles more easily and is pumped out. As the soil is cooled, however, gas is reabsorbed on the soil grains resulting in an effective increase in speed.

An early study proved that in the porosity experiments the soil was much less confined than in the direct shear tests, and therefore was undoubtedly outgassed more easily.

In order to simulate the vacuum present on the moon, a vacuum chamber test apparatus has been proposed. The interior of the chamber would be a cube with dimensions of 4' X 4' X 4'. The interior of the chamber would be constructed of stainless steel to limit the effects of outgassing. One side of the chamber has a hinged door in order to allow easy access.

Measurements on the system would be made through three different modes. A Pyrex glass window six inches in diameter will be installed on the chamber in order to visually calibrate the height of the penetrometer tip above the soil. Passthroughs will be provided by elastomer seals for an electrical current and a hydraulic line which are used for controls and data acquisition. Two types of gauges will be used to monitor the pressure of the vacuum chamber. A thermocouple gauge will be used for pressures down to

ORIGINAL PAGE IS
OF POOR QUALITY

10^{-2} torr and a cold cathode ionization gauge will provide pressure readings down to 10^{-6} torr.

The pumps for this system were designed to develop 10^{-6} torr in the chamber, which is considered the lowest feasible pressure for our experiment because of the outgassing effects of the soil specimen.

The pumping system for the vacuum is composed of two parts; a roughing pump and a diffusion pump. The roughing pump is used to take the chamber down to 10^{-2} torr. At this point the diffusion pump will cut in and take the system down to 10^{-6} torr, the maximum vacuum.

The pumpdown time for the roughing pump and the diffusion pump can be determined through the use of several formulas.

$$T = 2.3 \times (V/S_n) \times \log(P_1/P_2)$$

The above formula is used for the roughing pump. T is the time required for pumpdown to 10^{-2} torr, S_n is the speed of the pump in cubic feet per minute, P_1 is atmospheric pressure (approximately 750 torr), P_2 is the vacuum pressure (10^{-2} torr in this case), and V is the volume of the chamber.

The time required for the diffusion pump is more complicated because it is dependent upon the outgassing characteristics of the materials involved, the size of the materials, and the size of the diffusion pump. A system of equations for determining the pumpdown time required is as follows:

Q = area X outgassing coefficient
 $Q_{total} = Q_1 + Q_2 + Q_3 + \dots Q_n$
 L = the total length of connecting tubing
 a = radius of the pipe
 k = determined from charts using ratio L/a
 T = temperature
 A = area of connecting tube
 C = molecular conductance
 M = molecular wt. of air
 S_n = pumping speed at chamber wall
 S_p = pump speed at the mouth of the pump (speed given by manufacturer)
 P = final pressure of system
 $C = 3.64 KA X (T/M)$
 $S_n = (S_p X C)/(S_p + C)$
 $S_n = Q/P$

A system model proposed by High Vacuum Equipment Corporation (see Fig.3) would have a pumpdown time of approximately 16 hours (see sample calculations in appendix). This system would have all the parameters established at the beginning of this section. The pumps used on this system would be the 20 inch Varian diffusion pump with a net pumping speed of 17,500 l/sec and a Stokes 212 roughing pump with a speed of a 150 cubic feet per minute. A water cooled chevron baffle is used to minimize backstreaming of oil molecules from the pump.

ORIGINAL PAGE IS
 OF POOR QUALITY.

C. Soil Simulant

INTRODUCTION

In order to evaluate a lunar soil engagement device effectively, the mechanical properties and/or behavior of the soil must be modeled closely with some material. As there is little chance of obtaining actual lunar soil in the quantities necessary for the proposed number of tests, a suitable simulant must be chosen. This soil simulant must behave very nearly like lunar soil in the tests that are proposed; the static penetration test and the direct shear test. Several soil characteristics are involved in these two tests which must be considered in selecting a simulant.

CRITICAL PROPERTIES

For this experiment, the soil simulant should behave like lunar soil in the two tests proposed. In the shear test, which will be explained in section D, the simulant should yield values of cohesion (c) and friction angle (ϕ) similar to those measured on actual lunar soil. The static penetration test should produce values bearing capacity for the simulant comparable to actual lunar soil.

Another important characteristic of the soil simulant is compressibility. Compressibility deals with the change in density of the soil when it is compressed. Compressibility will not be measured directly by the proposed tests, however it is an important characteristic in the choice of soil simulant.

THE LUNAR SOIL

Tests on actual lunar soil have yielded a spectrum of data. These data include that from the Surveyors (I, III, VI, and VII), the Lunokhods (I and II), the Apollos (11, 12, 14, 15, 16, and 17) and the Lunas (16 and 20). All of this data was compiled for values of cohesion and friction angle by Carrier in an as yet unpublished manuscript. Shear strength data (which inherently includes cohesion and friction angle) has been plotted for these missions (see figure 4 in the appendix).

The Appolo 12 testing included soil compressibility measurement. As a result of this testing, values of $C = 0.01$ to 0.11 were recommended.

RECOMMENDED SIMULANT

A lunar soil simulant has been suggested by Carrier for earthbound mechanical properties testing. Here, a material and a grain size distribution are suggested which closely model lunar soil in testing. The soil simulant material is basaltic sand. The grain size distribution is attained by using different sieves on the sand. The grain size distribution is shown below in Table 1.

SIEVE NO.	OPENING (mm)	% FINER BY WEIGHT
12	1.68	95
50	0.297	79
100	0.149	66
200	0.074	50

TABLE 1: GRAIN SIZE DISTRIBUTION

It should be noted here that basalt, as it is obtained

ORIGINAL PAGE IS
OF POOR QUALITY

from commercial quarries may not have a very large percent of material which will go through a number 200 sieve. This can be remedied with a grinding machine to reduce the particle size.

SIMULANT PERFORMANCE

The performance of the lunar soil simulant in mechanical properties testing is very important. The simulant must be a reasonable model in terms of bulk density, shear strength, cohesion, friction angle, and compressibility.

On the basis of shear strength, cohesion, and friction angle; data given by Carrier suggests that on a shear strength versus normal load graph, the behavior of the simulant bounds the envelope produced by the Apollo, Lunokhod, and Surveyor missions. The shear strength behavior is varied by changing the relative density of the soil (see figure 4 in the appendix). Note that this simulant models the lunar soil accurately to at least 3 m of modelled depth caused by the normal load in the shear test.

In terms of compressibility (C), the lunar soil simulant suggested is not as compressible as actual lunar soil. This is true whether the soils are compared at the same density or void ratio.

Bulk density of the simulant can be varied a great deal to model different lunar conditions, especially depth. This is accomplished in the direct shear test by increasing the confining pressure. Compressibility does not model lunar

soil exactly, however the differences are small enough to yield accurate data.

CONCLUSION

The lunar soil simulant selected (as provided by Carrier) is suitable for the tests proposed. The particle size distribution allows for the ability to vary density as needed, as well as provide acceptable values of cohesion and friction angle. Compressibility, while not modelled as well is acceptable for the purposes of these tests.

ORIGINAL PAGE IS
OF POOR QUALITY

D. Shear Test

INTRODUCTION

The peak shear strength, internal angle of friction, and cohesion are important soil characteristics which should be considered in the design of lunar soil engagement equipment. Because it is a costly and laborious task to exactly simulate the lunar environment, it is desirable to simulate only those aspects which show an effect on the soil properties. It is the purpose of this section to propose a procedure for evaluating: (1) the effects of various environmental conditions on the shear properties of lunar soil and, (2) to determine the extent to which these conditions must be modelled for future tests.

The shear strength of soil is the resistance to deformation by continuous shear displacement of soil particles. The shear strength (τ), is given analytically by the following straight line equation, known as Coulomb's shear strength equation: $\tau = \sigma \tan \phi + c$ where the intercept (c) is termed the cohesion of soil. The slope of the line, $\tan \phi$, is the coefficient of internal friction and ϕ is the angle of internal friction. σ represents the normal stress on the failure plane. This relationship shows that the shear strength of a soil is proportional to the normal stress on the shear plane.

TESTING METHODS

One method of determining the shear properties of a soil is the direct shear test. In this test, the soil

ORIGINAL PAGE IS
OF POOR QUALITY

sample is placed in a shear box which is split horizontally into two parts. A normal load is applied and one half of the box is held while the other is pulled horizontally, shearing the soil. For any one test, the normal load is held constant while the shearing force and the shearing and vertical strains are recorded.

Using data from a series of tests, the normal loads may be plotted versus failure shearing loads to obtain a line following the Coulomb shear strength equation. In addition, a plot of strain versus the ratio of shear stress to normal stress for each test will yield the peak shear stress (see figure 5 in appendix A). The peak shear stress is the maximum value of shear stress that can be accommodated for a given normal load.

The shear properties of a soil may also be found using the triaxial compression test. In this test, a cylindrical soil sample is encased in a thin rubber membrane. It is then placed in a closed chamber and subjected to a fluid pressure. An axial load is then applied to both flat ends and is increased until failure occurs. From a series of tests, Mohr circles representing failure can be constructed. The common tangent to the circles represents the Coulomb shear strength line.

Because of the sandy, relatively cohesionless nature of basalt, and by extension lunar soil, the direct shear test is the most appropriate method for evaluating shear properties. Geotest Instrument Corporation manufactures a

ORIGINAL PAGE IS
OF POOR QUALITY.

direct shear apparatus (model #S2213) and a data recording system (model #S53281) which are suitable for the purposes of

the experiment (see figure 6 in appendix A). The direct shear apparatus can easily be set up for remote control and the data recording system may be set up outside of the vacuum chamber.

EQUIPMENT MODIFICATIONS

Equipment modifications can be divided into two categories:

- a. Those which are known to be necessary.
- b. Those whose need can only be established after the apparatus has been assembled and tested.

In the first category, a means of controlling the sample temperature must exist. It will be necessary to lower the sample to -200 degrees Fahrenheit and raise its temperature to 200 degrees Fahrenheit. Cavities for fluid flow can be drilled into the upper half of the shear box (see figure 2 in appendix A). Liquid nitrogen can then be pumped through the shear box to cool the sample. The sample may be heated by pumping steam through these same cavities. The flow rates required to achieve the desired temperature will have to be determined experimentally (see calculations in appendix B). Side effects of the previously covered heating and cooling techniques may require additional equipment modifications. Heat transfer will primarily take place through conduction. The absence of air in the vacuum chamber prohibits heat transfer by convection. Due to the relatively low temperature difference approximately 135

ORIGINAL PAGE IS
OF POOR QUALITY.

degrees Fahrenheit), radiation losses are expected to be negligible. Heat could be conducted to the load cell, vertical load shaft, or the horizontal load shaft.

Thermocouples should be placed on these components during a mock setup and their temperatures should be monitored to evaluate the need for corrective measures. If any of these temperatures approach an unsafe or uncalibrated temperature, then the respective component must be heated or cooled as needed. These components can be heated or cooled easily and economically by wrapping four or five coils of 3/8 diameter copper tubing around them and attaching the tubing with silver solder. Water should then be pumped through the coils to achieve the proper temperature.

PROCEDURE

The following procedure describes the method for actually conducting the direct shear test. The previously described equipment modification, sample preparation, and necessary corrective measures must be completed prior to conducting the tests.

1.0 Initial Setup

1.1 Level machine using adjustable feet.

1.2 Install horizontal LVDT-dial combination. This is the unit with the longer travel. Without disturbing the position of the LVDT with relation to the dial indicator, insert shell of LVDT all the way into mounting block. Make sure the dial tip faces the shear box. Tighten the small knurled screw on block so that the LVDT-dial indicator

ORIGINAL PAGE IS
OF POOR QUALITY

cannot move. This knurled screw is also used to adjust the zero. Plug in the electrical connector to "Horizontal LVDT."

1.3 Remove packing material, upper loading cap and upper porous plate from inner shear box. The two halves of the inner shear box are held together by two screws with large knurled tops. Tighten the knurled screws prior to forming the sample and preconsolidation. After preconsolidation and just prior to shearing, remove the knurled screws. The four corner screws should now be tightened sufficiently to slightly separate the top and bottom of the shear box. Once preset, these four screws may not require further adjustment on subsequent tests. The four screws pre-load teflon pads that separate the shear box halves with minimal friction and prevent metal to metal contact with subsequent scoring. When the four screws are preset properly, they will compress the teflon pads sufficiently to close the gap during subsequent forming and preconsolidation of the sample.

1.4 Install the vertical loading assembly after the sample is in the shear box: Place the loading assembly over the center of the shear box so that the slots in the legs fall onto the alignment pins. The 1/2 " diameter rod with knurled end is then inserted through the front and rear legs of the cylinder and frame. Make sure the rod goes all the way through both legs. Attach 1/8" flexible plastic tube to air cylinder.

1.5 Install vertical LVDT-dial indicator: Base of dial indicator with tip down is inserted into dial holder arm on air cylinder. Tighten allen screw and zero dial after initial vertical load is placed on sample. Plug in electrical connector to "Vertical LVDT." Position wire so that it will not interfere with test.

1.6 Preset strain rate:

- a. Be sure the pin connecting load cell to loading yoke is removed.
- b. Turn on "main power" switch.
- c. Turn "rate" control knob completely counter-clockwise.
- d. Push "start" button.
- e. Turn "rate" knob clockwise to desired strain rate as indicated on readout in inches per minute divided by 10.
- f. Push "stop" button.

1.7 Place machine in vacuum chamber.

1.8 Centering shear box housing: Remove the anti-rotation pin on the gear box assembly. Rotate the hand wheel in the direction necessary to line up the holes in the loading yoke and the load cell extension rod. Insert the pin from rear of machine. Re-insert the anti-rotation pin on the gear box assembly. The load cell should now read zero. If the load cell does not read zero, turn the large knurled load cell adjusting nut until zero reading appears on the appropriate digital readout.

1.9 Setting Travel Limit Switches:

The desired length of travel in both directions from

center position of shear box must be set at this time. Length of travel can be set between 0 and 0.8" in both directions. Decide desired length; select a spacer that matches desired travel and set limits in following manner: loosen knurled limit adjusting screws and slide limit switch assembly away from the shear box housing. Place the spacer against housing and slide the limit assembly towards the spacer until a faint audible click is heard. Tighten the knurled adjusting screw and repeat the process with the other limit assembly.

2.0 Test Procedure

2.1 Make sure all three air valves are closed by turning clockwise. Do not overtighten.

2.2 Connect the coil of tubing under the frame to an appropriate air source. 200 PSI is needed to reach full capacity of 2200 lb vertical load. Plug in line cord to 115 VAC outlet. Turn on the "main power" switch.

2.3 Turn the "supply valve" with gage on cabinet indicating line pressure. Before the air system is activated by opening the "load apply" valve, the readout will show a negative load. This is due to the pressure required to overcome the return spring in the air cylinder. When the supply valve is opened, the readout will go to zero or a slight positive value. If the initial value is too high, slightly crack the "vent" valve to achieve the desired reading. Now open the "load apply" valve and apply the initial load to the sample. The porous plate should now be

seated and it is important to again zero the vertical LVDT-dial indicator by loosening the allen screw and retightening.

2.4 Applying Normal Loads:

Always close "load apply" valve before increasing the normal load, advance the readout to the next desired normal load by turning the regulator clockwise. When the desired reading is reached, apply the load to the sample by opening the "load apply" valve.

During the shearing portion of the test, the "load apply" valve must be left open; the SMS regulator will maintain precise normal load only if the valve is open.

2.5 Shearing the Sample

Begin the shearing portion of the test by pushing the "start" button. The rate of strain has previously been set. The machine will cycle until the operator determines the test is complete.

2.6 Completion of the test

Try to end at the middle of the cycle. This eliminates the need to recenter the shear box housing.

- a. Shut the "supply" valve and open the "vent" valve.
- b. Turn the regulator counter-clockwise.
- c. Shut off "main power" switch.
- d. Remove air cylinder--be sure to disconnect line and remove the vertical LVDT-dial indicator by loosening the allen screw.
- e. Remove and clean the shear box.

E. Static Cone Penetration Test

INTRODUCTION

The static cone penetration test is widely used to determine the penetration resistance and bearing capacity of granular soil. The accuracy of settlement determination of granular soil depends on correspondence between those factors that affect soil compressibility and those factors that affect penetration resistance. Since it is unlikely that the factors affecting compressibility and penetration resistance are entirely the same or of equal influence on soil compressibility and penetration resistance, settlement predictions must have limited accuracy. Traditionally, most practicing engineers continue to regard bulk density as the factor of overriding importance in controlling compressibility.

The factors that affect the static cone penetration test (SCPT) are frequently not associated with properties of the soil. Factors which control SCPT results can be divided into a number of groups:

- a. Ground conditions
- b. Temperature
- c. Atmosphere
- d. Gravity
- e. Test method

The compressibility of granular soil is highly dependent on its yielding behavior. Therefore, the penetration resistance is largely dependent on the internal angle of friction of the soil and its effective stress plane.

MODES OF FAILURE

The penetration of a cone projectile into soil is a very complex phenomenon which is not easily analyzed by mathematical treatment. There are two ways in which the soil may fail under the projectile. One is by compression of the soil which is basically a reduction in void ratio or interparticle spacing caused by rearrangement of the grain structure. The other is by shear which consists of deformation of the soil particle and may or may not be assisted by a change in particle spacing. Either one or both of these methods of failure may occur during penetration. For a loosely packed sample, the soil below the cone will be compressed and accelerated initially. Depending on the force of the penetrometer, failure will occur by compression of the cone in this region below the cone. In a densely prepared sample, very little compression will occur and failure will take place primarily by the displacement of soil along shear planes. The amount of energy required to cause penetration, therefore, will be highly dependent on the relationship of the soil and its shear strength.

PENETROMETER

Penetration tests have long been used to evaluate soil consistency and density. The primitive builder may have sounded the ground with a pointed stick or his heel, as can be seen in tribal villages today. The skilled workman forced the point of a pick or drove a rod into the ground

with a mallet of known weight. Today there are numerous penetrometers of standardized design, but all are based on the same principle; the penetration of an object into the soil, forcing the soil aside and developing a shear displacement similar to the bearing capacity failure of a foundation.

Various shapes of penetrometers are in use, including flat-tipped rods, cones of different sizes and shapes, augers with cone-shaped tips, and cutting edges of thick-walled samplers. There is comparative data available upon the effect of shape on test results. Two types of loading are used, static and dynamic. Static loading simulates the shear developed in laboratory testing and can be easily adapted to continuous penetration and automatic recording. Dynamic loading is adapted to a very wide range of soil strengths but introduces the variable effect of dynamic shear and shock or vibration. The dynamic penetration has long been used in terrestrial soil mechanics as a measure of the bearing capacity. It has never, however, given as reliable results as the static penetration test. It is for this reason that the static penetration test was chosen.

The type static penetrometer we chose to use is a Brainard Kilman type AP-2100 with a 1'-6" rod assembly (Fig. 7). The penetrometer consists of a 60 degree apex angle cone, rod assembly, head assembly and gauge. The cone has a maximum section of 1.5 cm² made of stainless steel. The 60

degree apex angle is the maximum angle available with utilization of the static penetrometer. This angle was chosen because of its accuracy in obtaining results in a cohesionless soil. A small apex angle would essentially slide through the soil initially and give inaccurate results. The rod assembly of the penetrometer consists of an outer rod and an inner rod. The outer rod is made of Centerless Ground 316 Stainless Steel. The head assembly consists of handles and a strain gauge; however, these two items will be modified as per equipment modifications section. The head assembly is made from high strength, light weight 6061-T6 Aluminum, anodized for protection. Stainless inserts prevent rod threads from wearing. Smoothly finished inside bore and piston account for a low friction coefficient. The gauge is 2.5 inches in diameter with a range of 0-1000 pounds. It has a built-in gauge zeroing adjustment.

The static cone test implements a simple concept. The operator pushes a simple cone-shaped steel point into the soil with a constant velocity. He measures the thrust to accomplish this and divides by the projected end area of the point to give the cone bearing capacity. The Brainard-Kilman Static Cone Penetrometer features dual rod construction. As the inner rod functions independently of the outer rod, soil friction is not a factor with this unit. Cone stress as read on the gauge can be easily correlated to local constants without having to adjust for the soil.

friction coefficient.

Equipment Modifications

Some equipment modifications were found to be necessary in order to achieve maximum environmental simulation. To actuate the penetrometer manually would require an opening to be made in the vacuum chamber that would enable the penetrometer to move freely. This guide opening would not allow the pressure inside the vacuum chamber to reach the desired range. A decision was made to remotely actuate the penetrometer hydraulically which would eliminate having to penetrate the chamber vacuum (see Fig.7).

Since the penetrometer will be hydraulically actuated the head assembly will include no handles. To remove handles from the head assembly requires only for them to be unscrewed. The head assembly will be tapped to include four 3/8 inch steel bolts at a depth of 3/4 inch.

The maximum force that the penetrometer can withstand before buckling is 1200 pounds for a rod length of 18 inches. The hydraulic actuator was selected from Victor Fluid Power Inc. and has a lifting capacity of 1000 pounds. The support truss height was determined from the length of the penetrometer and actuator when fully extended such that a 2 inch clearance will remain between the conical tip and the base of the sample container (see Fig.8). The width of the member was sized according to the base of the actuator, which is five inches (see appendix B for force analysis of support truss).

Since the pressure gauge cannot be read through the vacuum chamber window, it will be routed outside the chamber through the prescribed outlet with the Tigon Flex tubing so that the gauge can be read from a control panel (see Fig.9). The temperature gradient will be isolated to the soil sample to avoid having to apply additional modifications to the testing equipment that might limit the simulation of temperature. A self-contained heating and cooling unit will be utilized in providing this temperature gradient to the soil sample alone (see section B). The dimensions of the self-contained temperature unit are dependent on the size of the soil sample container (see Fig.1). With the aid of Brainard and Kilman Inc., a series of preliminary experiments were performed in order to determine the minimum size soil container which would have no effects on the results. A series of test were conducted in which the container's diameter and depth were varied in order to obtain a container in which the edge and bottom effects would be minimized. The size determined for the penetration experiment, therefore, was a cylindrical container 10 inches in diameter and 8 inches deep. This will permit the experiments to be performed in the sample at a minimum distance of 3 inches from the container wall and 2 inches from the bottom of the container.

For the flight portion of our testing procedure, the sample will be secured by a sample holder to prevent horizontal shifting and by a containment ring which prevents

vertical movement (see Fig.8).

Performance

The static cone penetration test will enable the measurement of penetration resistance and the determination of the bearing capacity. The penetration force or resistance can be read directly from the gauge of the testing apparatus for various depths. The depth of penetration can be read through the window of the vacuum chamber. Graphs can be generated which show the soil resistance as a function of cone depth (see Fig.10). The penetration force, as indicated by the gauge, divided by the base area of the cone gives the bearing capacity which is expressed by the following equation:

$$q_c = F/A$$

F = soil resistance

A = area of cone

(see sample calculations, appendix B)

The bearing capacity is a factor of soil mechanics that deals with normal force opposing a projectile as it shears through the soil. The punching or penetration stress of an ideal plastic medium as described by Prandtl can be expressed by:

$$\tau_p = Ns$$

where τ_p is the average penetration stress, s is the shear resistance or stress of the medium, and N is a coefficient which depends on the geometry of the point and surface and on the angle of internal friction which is obtained from the direct shear test. For cohesionless soil such as basalt,

the internal friction angle is 30 to 50 degrees and for cone angles of 60 degrees, N is approximately 7.

The static cone penetrometer applies a static force to a point sufficiently great to produce shear failure. Therefore, the bearing capacity for a foundation the same size and shape of the cone is measured directly at that depth below the surface.

N can be found theoretically or by experiment. This procedure allows continuous measurement of resistance with increasing depth by advancing the cone and measuring the necessary force. The amount of work required to force the penetrometer a distance x can be determined by the following equation.

$$\Delta W = \Delta x A T_p$$

x = penetration distance
 T_p = penetration stress (see sample calc., appendix B)
A = penetrometer cone area

Once the soil sample has been prepared the following stages of a procedure will be carried out.

- 1.) Check apparatus
- 2.) Position sample container
- 3.) Adjust cone
- 4.) Sample calculations and plots

Procedure

CHECK APPARATUS

The operator should see to it that the cone point and rods are clean and in good alignment. The sharpness of the cone point can be checked by pushing the tip into the hole of the sharpness gauge plate. If the point cannot be felt when brushed lightly with the tip of the finger, the cone

should be replaced. Proper alignment should be checked so that friction between the inner and outer rods doesn't introduce error in the experiment. The hydraulic controls, thermocouples, and heating device should be checked for proper calibration and performance.

PLACEMENT OF SAMPLE CONTAINER

After the soil sample has been through the proper moisture bakeout and particle distribution procedures the sample may be placed in the self-contained heating and cooling unit. The sample is then heated or cooled to the desired temperature which is measured by thermocouples.

ADJUST CONE

The cone and its support should be carefully lowered to the surface of the soil. Care must be taken to insure that the test is conducted 3 inches away from the edge of the container to avoid inducing error from the side effect of the container.

MEASURE CONE PENETRATION

Apply the desired load and then measure the total penetration. All of the loads include the weight of the cone and shaft. The corrections shall be taken care of by subtracting the same amount from all readings.

SAMPLE CALCULATIONS AND PLOTS

Once the penetration and direct shear test have been conducted the data from these tests will be used to calculate the bearing capacity and shear strength of the soil. The amount of work done on the penetrometer can also

be determined. Plots of soil resistance vs. depth can be generated.

The static cone penetrometer provides an economical method for investigating the homogeneity of foundation soil conditions. It has proven especially useful when evaluating the homogeneity and strength characteristics of cohesionless soils. The soil properties obtained from this test prove useful in determining foundations for building and digging equipment for construction.

F. Test Procedure

SAMPLE PREPERATION

Sample preparation is the first stage in the experimental procedure. The steps in sample preparation involve obtaining a given particle size, eliminating moisture, and trimming the sample. The behavior of soil is related to its particle size. The particle size as suggested by Carrier will be obtained using a sieve shaker, Inclynotype (see appendix D).

The Inclyno sieve shaker consist of a series of sieves that have openings approximately one-half that of the coarser above it in the nest. The nest of sieves are clamped to the vibrating platform which vibrates in a horizontal direction.

The sand samples are prepared by pouring the basalt in to the shear box and penetrometer container through a tube with a slotted end piece which ensures that the velocities of the basalt grains are close to zero as they leave the tube. By controlling the velocity of the grains leaving the tube and the tube height above the surface of the deposited soil (about 1/4 in.) an even particle spacing can be acheived. The desired density can be acheived by applying a uniform load to the sample and measuring the height of the soil within the soil container itself (see appendix D).

Since the penetration stress is dependent upon the geometry of the surface which the cone penetrometer penetrates the sample, the sample will be trimmed until it is level. Ensuring that the soil sample is level will

simplify the mathematics in determining the penetration stress as previously mentioned. The sample will be levelled with the aid of a trimming tool, (See appendix D).

The majority of the moisture in the sample will be removed by baking the sample. An electric oven will be used to bake the sample prior to placing it in the vacuum chamber. After a sufficient baking period the samples will be removed from the oven and placed into their respective self contained heating and cooling units. Before the chamber is depressurized the samples will be heated to remove any moisture gained during the transfer from the oven to the chamber. Once the moisture content of 1% is reached, the outgassing and temperature processes can be carried out.

EXPERIMENTATION

The second stage in the procedure involves conducting the experiment both in a ground based laboratory and in flight in a minilab on the maximum simulation of the lunar environment. The aircraft follows a parabolic flight path from which it can maintain a reduced gravity environment for approximately two minutes. This time period is ample to carry out the experimental procedures.

Several possible testing arrangements were considered to determine which arrangements would provide the most conclusive results. If funding permitted, it would be possible to conduct the flight portion of the experiment with several simultaneous equipment set-ups in which the density and the environmental conditions would vary while

only making one flight. However, the decision was made to use the same testing apparatus for both flight and ground based experiments.

There will be ten flights made by the KC-135 in which the density of soil, soil temperature, vacuum pressure, and a reduced gravitation pull will be varied. The first flight experiment will simulate the maximum environmental conditions and the most densely packed soil sample. The conditions which are to be met are as follows:

- (1) reduced gravitational pull of 1.63 m/s^2
- (2) soil temperature of 200 degrees Fahrenheit
- (3) vacuum pressure of 10^{-6} torr
- (4) soil density of 3.24 g/cm^3

The second flight experiment will vary the gravitational pull in order to help determine to what extent gravity influences the mechanical properties of basalt. The following conditions are to be met:

- (1) reduced gravitational pull of 4.0 m/s^2
- (2) soil temperature of 200 degrees Fahrenheit
- (3) vacuum pressure of 10^{-6} torr
- (4) soil density of 3.24 g/cm^3

Flights three, four, five, and six will be conducted varying the temperature from -200, -100, 100, 200 respectively. All other conditions will be held constant. The following conditions are to be met for flights 3 through 6.

- (1) reduced gravitational pull of 1.63 m/s^2
- (2) soil temperature of -200, -100, 100, 200 degree F.
- (3) vacuum pressure of 10^{-6} torr
- (4) soil density of 3.24 g/cm^3

The seventh and eighth flights will be conducted varying the vacuum pressure while keeping all other conditions constant. Atmospheric pressure (750 torr.) and 10 torr will be the

testing pressures. The condition requirements are as follows:

- (1) reduced gravitational pull of 1.63 m/s^2
- (2) soil temperature of 200 degree Fahrenheit
- (3) vacuum pressure of 10^{-3} to 750 torr
- (4) soil density of 3.24 g/cm^3

In flights nine and ten the soil density will be varied so as to aid in determining how the environmental conditions vary with loosely and densely packed samples. The following conditions are to be met:

- (1) reduced gravitational pull of 1.63 m/s^2
- (2) soil temperature of 200 degree Fahrenheit
- (3) vacuum pressure of 10^{-6} torr
- (4) soil density of 1.36 g/cm^3 to 2.3 g/cm^3

There will be eight tests conducted on earth in a laboratory in which the environmental requirements are the same as the flight experiment neglecting the simulation of gravity. Experiments one through eight vary the temperature, vacuum pressure, and soil density respectively (see following procedure steps).

The results of the tests will be compared to determine to what extent the environmental conditions must be simulated in order to design a digging implement that would work most efficient in the lunar environment. The intent of the proposed procedure is not to limit the testing procedure to the suggested objectives, but should be able to yield data that would be representative actual lunar soil.

PROCEDURE

I Sample Preparation

- (1) Weigh to 1000 grams each sieve which is to be used. Make sure each sieve is clean before weighing

ORIGINAL PAGE IS
OF POOR QUALITY.

- it.
- (2) Sieve the soil through a series of sieves using a mechanical shaker.
 - (3) Funnel soil into their respective sample container.
 - (4) Pack container to prescribed height to obtain desired density.
 - (5) Trim sample to ensure a level surface.
 - (6) Bake sample at 500 degree Fahrenheit for 1 hour.
 - (7) Place samples in self-contained heating and cooling unit and heat at 250 degree Fahrenheit for one hour.
 - (8) Simultaneously begin outgassing procedure and temperature setting.

II. In flight environmental condition requirements

Flight I		
(1)	reduced gravitational pull of	1.63 m/s ²
(2)	soil temperature of	200 degrees F
(3)	vacuum pressure of	10 ⁻⁶ torr
(4)	soil density of	3.24 g/cm ³
Flight II		
(1)	"	4.9 m/s ²
(2)	"	200 degrees F
(3)	"	10 ⁻⁶ torr
(4)	"	3/24 g/cm ³
Flight III		
(1)	"	1.63 m/s ²
(2)	"	-200 degrees F
(3)	"	10 ⁻⁶ torr
(4)	"	3.24 g/cm ³
Flight IV		
(4)	"	1.63 m/s ²
(5)	"	-100 degrees F
(3)	"	10 ⁻⁶ torr
(4)	"	3.24 g/cm ³
Flight V		
(1)	"	1.63 m/s ²
(2)	"	100 degrees F
(3)	"	10 ⁻⁶ torr
(4)	"	3.24 g/cm ³
Flight VI		
(1)	"	1.63 m/s ²
(2)	"	200 degrees F
(3)	"	10 ⁻⁶ torr
(4)	"	3.24 g/cm ³
Flight VII		

ORIGINAL PAGE IS
OF POOR QUALITY

(1)	"	1.63 m/s ²
(2)	"	200 degrees F
(3)	"	10 ⁻³ torr
(4)	"	3.24 g/cm ³
Flight IIX		
(1)	"	1.63 m/s ²
(2)	"	200 degrees F
(3)	"	750 torr
(4)	"	3.24 g/cm ³
Flight IX		
(1)	"	1.63 m/s ²
(2)	"	200 degrees F
(3)	"	10 ⁻⁶ torr
(4)	"	1.36 g/cm ³
Flight X		
(1)	"	1.63 m/s ²
(2)	"	200 degrees F
(3)	"	10 ⁻⁶ torr
(4)	"	2.3 g/cm ³

III. Ground based environmental condition requirements

Test I		
(1)	soil temperature of	-200 degrees F
(2)	vacuum pressure of	10 ⁻⁶ torr
(3)	soil density of	3.24 g/cm ³
Test II		
(1)	"	-100 degrees F
(2)	"	10 ⁻⁶ torr
(3)	"	3.24 g/cm ³
Test III		
(1)	"	100 degrees F
(2)	"	10 ⁻⁶ torr
(3)	"	3.24 g/cm ³
Test IV		
(1)	"	200 degrees F
(2)	"	10 ⁻⁶ torr
(3)	"	3.24 g/cm ³
Test V		
(1)	"	200 degrees F
(2)	"	10 ⁻³ torr
(3)	"	3.24 g/cm ³
Test VI		
(1)	"	200 degrees F
(2)	"	750 torr
(3)	"	3.24 g/cm ³

Test VII	"	200 degrees F
(1)	"	10^{-6} torr
(2)	"	1.36 g/cm^3
(3)	"	
Test VIII	"	200 degrees F
(1)	"	10^{-6} torr
(2)	"	2.3 g/cm^3
(3)	"	

6. Digging Implement Methodology

INTRODUCTION

The results obtained from our design project will be utilized for the design of a lunar digging implement. The design of this implement is beyond the scope of our project; however, a methodology will be given to explain how the results of our design project can be applied to the design of the implement.

CONSTRAINTS

As mentioned earlier in our report, the lunar environment displays some very adverse conditions which will affect equipment which might be exposed to it.

SOIL MECHANICS

Soil interaction is a very critical concept in the design of a lunar digging implement. It must be considered since the design will need to optimize a bucket/soil removal system. Some of the more critical factors which must be taken into consideration are angle of cut and bearing capacity. The cutting of the bucket blade through the soil is a very important feature. The angle at which the cutting edge is designed is very critical in minimizing the forces required to push the bucket through the soil. This angle is the same as the internal angle of friction of the soil. The internal angle of friction of the soil is determined from the direct shear test which is described above in the report.

Designing the cutting edge of the digging implement at an

angle which is equal to the internal angle of friction of the soil not only reduces the normal forces against the blade, but also reduces blade wear.

The bearing capacity deals with the normal forces opposing the bucket blade as the blade shears through the soil. Lunar soil bearing capacity increases with soil depth due to numerous years of compaction. The bearing capacity is determined from the static cone penetrometer which is described in full detail previously in the report. The bearing capacity is the normal force per unit area. This can be utilized in determining the size and geometry of the implement.

The extending force of the implement must be enough to supply an acceleration capable of penetrating the soil. The penetration force can be read directly from the penetrometer gage for various depths. Once the maximum force has been determined the acceleration of the implement can be determined from the following equation:

$$R = m(a-g)$$

R is soil penetration resistance.
m is the mass of the digging implement.
a is the acceleration of the implement.
g is the gravitational constant.

The amount of work required to force the implement a distance Δx can be determined by the following equation:

$$\Delta W = \Delta x \tau_p A$$

Δx is the penetration distance.
 τ_p is the penetration stress.
A is the implement area.

TEMPERATURES

As mentioned previously in the report, the temperatures

on the moon are very extreme. They range from -200 degrees Fahrenheit to 200 degrees Fahrenheit. Thus, an object sitting partially in the shade will have a temperature of -200 degrees Fahrenheit for the the shaded portion and a temperature of 200 degrees Fahrenheit for the exposed portion, creating very large thermal stresses in the material.

WEIGHT

Due to the extreme cost of shipping material to the moon, weight is a very important concern. In order to minimize weight, maximization of other constraints must be considered.

RADIATION

The main thing to consider about radiation is its affect on materials. Research has been conducted concerning radiation, and it was found that radiation effects on metals, in general, are very small. Ultimately, radiation has almost no effect on physical properties at all.

MATERIALS

A very important criteria of the digging implement is strength versus weight ratio. This ratio indicates the materials which are extremely strong for their densities. As stated above, the lunar environment displays very large temperature variations. For this reason, any type of equipment or material working in this environment must be able to withstand these extreme conditions.

It was found during our research that lunar soil is

very gritty and coarse. This characteristic of the soil will result in extreme wear on exposed surfaces and might cause failure due to poorly designed equipment. Based on the knowledge which our group has obtained concerning this subject, it would be advisable to coat the digging implement with teflon for overall wear resistance. Another important feature which is advisable is to design the digging implement with replaceable teeth on the cutting edge in order to absorb wear. This will result in a major long term cost savings and also reduce major wear on the main shell of the digging implement.

Another important characteristic which must be considered is equipment elongation. The extreme environmental conditions on the moon, mainly temperature, can cause a piece of equipment to fail if the material's elongation is not taken into consideration. For this reason, thermal stress calculations must be performed in order to determine the type material which is best suited for lunar equipment.

The geometry too must be considered when designing a lunar digging implement. This shape must be broken down into optimum dimensions, internal radii, capacity, and weight.

IV. PARTS LIST

Penetrometer:

Quantity	Description	Model	Price
1	Baseplate (aluminum) 15in.x 15in.x 3/4 in.	N/A	
4	Insulated Isolaters 1in. dia. x 1/8 in.	N/A	\$10.00
1	Heating and Cooling Pad 12in. x 12in. x 1in.	WP-1200	\$100.00
1	Soil Sample Container 10in. dia. x 8 in.	N/A	\$20.00
1	Penetrometer 18 in.	B-K AP-2100	\$600.00
1	Hydraulic Actuator 1/2 ton	Victor Fluids VF-H500	\$30.00
1	Aluminum Support Truss 1in. x 5in. x 56in.	N/A	\$30.00
4	Steel Bolts 3/8in. x 3/4in.	N/A	\$2.00
4	Steel Bolt 3/8in. x 10in.	N/A	\$4.00
4	Steel Bolts 3/8in. x 1in.	N/A	\$2.00
1	Data Aquisition System	Brainard Kilman	\$2000.00
1	Flange 10in. dia. x 1in.	N/A	\$2.00
	Subtotal		\$2780.00
	Equipment Modifications		\$250.00
	Total		\$3030.00

ORIGINAL PAGE IS
OF POOR QUALITY.

Shear Tester:

<u>Quantity</u>	<u>Description</u>	<u>Model</u>	<u>Price</u>
1	Shear Test Apparatus	Geotest S2215	\$12200.00
1	Data Aquisition	Geotest S3281	\$2525.00
		Subtotal	\$14725.00
	<u>Equipment Modifications</u>		\$150.00
		Total	\$14875.00

Vacuum Apparatus

1	Vacuum Chamber 4ft. x 4ft. x 4ft.	High Vac Equip. Corp.	\$150000.00
---	--------------------------------------	--------------------------	-------------

Gravity Simulation

Flight of the KC-135 Estimated Flight Time= 1hour/trial
Rate of Fuel Consumption=20000 lb/hr
Price per pound of fuel=\$0.20

V. CONCLUSIONS

Since the scope of this report concerns the development of a methodology and equipment designed to carry out the experiment, the conclusions are based on the methodology, equipment, and the project in general.

The proposed methodology and equipment should yield information allowing the most cost and time effective means for future testing and evaluation of lunar soil engaging equipment. In simpler terms, this means that if a certain parameter does not affect the mechanical properties in a substantial way, then that parameter is not modeled; thus conserving time and money.

It is also concluded that this project required a great deal of research on the basic civil engineering principles involved in mechanical properties testing of soil. While these principles are not complex, no one in our design group had been previously exposed to them. It was a goal of the group to give a firm foundation in the civil engineering aspects of our project so that subsequent work in this area will be facilitated.

In terms of the overall value of the project, the design group feels that we benefitted in several areas. First, we all learned of the workings of groups through our experience with each other. We also developed a professional attitude by dealing with vendors and engineers in the fields of mechanical and civil engineering. We also feel that we have learned a great deal about the organization and delegation of project duties. Lastly and most important, we feel that we have greatly enhanced our ability to step back from a problem, analyze it clearly, and

develop a plan for its solution.

VI. RECOMMENDATIONS

The use of Computer Aided Design is a tremendous asset to the design process. We, therefore, recommend that the next group familiarize themselves with the available systems as quickly as possible.

Conversations with Nasa can be great help when a problem is encountered. More conversations should be conducted so as to utilize their knowledge to the design's benefit.

This project was an initial design of a new idea. the design procedure is not finalized, because improvements in certain areas are possible. The following areas are recommended for further investigation.

- 1). Eventhough the shear tester is a state of the art testing apparatus, it utilizes an analog system. In order to obtain better data acquisition, the system should be converted to a digital system.
- 2). Obtaining a data acquisition unit for the penetrometer was difficult since most of the data is obtained by manual calculation.
- 3). Further analysis in the methodology of the testing in terms of which parameters to vary to yield the most information may be beneficial.
- 4). Recommend that next group devise more specific methods where by the data accumulated will be used in the design of lunar equipment (i.e. how do you use this information in design process, what are implications.)

VII. Acknowledgements

Battiste, Richard; Development Engineer, Oak Ridge National Laboratories, Oak Ridge, Tennessee

Bachus, Robert; personal interview-July 22, 1987, School of Civil Engineering, Georgia Institute of Technology

Barksdale, Richard; personal interview-July 30, 1987, School of Civil Engineering, Georgia Institute of Technology

Brown, D.; personal interview, teaching assistant, School of Civil Engineering

Burns, Mike; telephone interview-August 17, 1987, High Vacuum Equipment Corporation, Mass.

Carrier, David, III; telephone interview, Principle, Bromwell and Carrier Inc., Lakeland, Florida

Conrade, Don; personal interview-August 4, 1987, Brainard Kilman Inc.

Desai, P.V.; personal interview, Associate Professor, School of Mechanical Engineering, Georgia Institute of Technology

McLaren, Brice;

McMurray, Gary; teaching assistant, School of Mechanical Engineering, Georgia Institute of Technology

Patten, A.; Chief Engineer, Geotest Instrument Corporation, Lincolnwood, Illinois

Perkins, Ed; personal interview, teaching assistant, School of Civil Engineering, Georgia Institute of Technology

Williams, Dr. W.W.; Group Advisor-Design Project, Professor, School of Mechanical Engineering, Georgia Institute of Technology

Woldenberg, J.M., President, Geotest Instrument Corporation, Lincolnwood, Illinois

VIII. BIBLIOGRAPHY

- ASTM; Procedures For Testing Soils, Baltimore, ASTM, 1964
- ASTM; Procedures For Testing Soils, Baltimore, ASTM, 1944
- ASTM; Special Procedures For Testing Soil and Rock For Engineering Purposes 5th edition, Easton, Md., ASTM, 1970
- ASTM; Symposium on Direct Shear Testing of Soils, New York, 1952
- Baldwin, R.; The Face of the Moon, Chicago, University of Chicago Press, 1949
- Bowles, Joseph; Engineering Properties of Soils and Their Measurements, New York, McGraw-Hill, 1970
- Carrier, David, III; Rough Manuscript on forthcoming book concerning lunar materials, Lakeland, Fla., 1987
- Chamberlain, J. and Watkins, C.; The Apollo 15 Lunar Samples, Houston, The Lunar Science Institute, 1972
- Costes, N. and Mitchell, J.; Proceedings of the Lunar Science Conference Volume 3: Physical Properties, "Apollo 11 Soil Mechanics Investigation", New York, Pergamon Press, 1970.
- Durgunoglu, H. and Mitchel, J.; Static Penetration Resistance of Soils, NASA-CR-133460, 1973
- Fielder, G.; Geology and Physics of the Moon, Amsterdam, Elsevier Publishing Co., 1971
- Fielder, G.; Lunar Geology, London, Lutterworth Press, 1965
- Geochemica et Cosmochemica ACTA; Proceedings of the Second Lunar Science Conference Vol. 1, Houston, The MIT Press, 1971
- Guest, J.E. and Greeley, R.; Geology on the Moon, London, Wykeham Publications, 1977
- Habib, Pierre; An Outline of Soil and Rock Mechanics, New York, Cambridge Press, 1983
- Head, K.; Manual of Laboratory Soil Testing Vol. 1, New York, Halsted Press, 1980
- Hubbard, J., Gall, E. and Kahn, H., Lunar Soil Simulant Study Phase B-Part I & II, Chgo, Dept. of the Army, 1969

- Jumikis, A.R.; Introduction to Soil Mechanics, Princeton, NJ, Van Nostrand Company, 1957
- Karol, R.H.; Soils and Soil Engineering, Englewood Cliffs, NJ, Prentice Hall, 1960
- Krieth, Frank; Basic Heat Transfer, New York, Harper and Row, 1980
- Kezdi, Arpad; Handbook of Soil Mechanics, Amsterdam, Elsevier Scientific, 1974
- Lambe, T.; Soil Testing For Engineers, New York, Wiley and Sons, 1951
- LaPelle, R.R.; Practical Vacuum Systems, New York, McGraw Hill, 1972
- Lienhard, J.; A Heat Transfer Textbook, New Jersey, Prentice-Hall, 1981
- Lindsay, John F.; Lunar Stratigraphy and Sedimentology, New York, Elsevier Scientific Publishing Co., 1976
- Popov, Egor; Introduction to the Mechanics of Solids, New Jersey, Prentice-Hall, 1968
- Rittenhouse, J.B. and Singletary, J.B.; Space Materials Handbook-3rd Edition, Lockheed Palo-Alto Research Laboratory
- Salisbury, G.; The Lunar Surface Layer, New York, Academic Press, 1964
- Shigley, J. and Mitchell, L., Mechanical Engineering Design, New York, McGraw Hill, 1983
- Singh, A.; Soil Engineering in Theory and Practice, New York, APT Books Inc., 1981
- Symonds, W.A., Design Mission and Environmental Considerations in the Selection of Materials for Space, Seattle, Wash., The Boeing Company

IX. LIST OF APPENDICES

- Appendix A: Design Drawings
- Appendix B: Sample Calculations
- Appendix C: Design Decisions
- Appendix D: After Market Equipment
- Appendix E: Weekly Progress Reports
- Appendix F: Miscellaneous

APPENDIX A
DESIGN DRAWINGS

HEATING ELEMENT

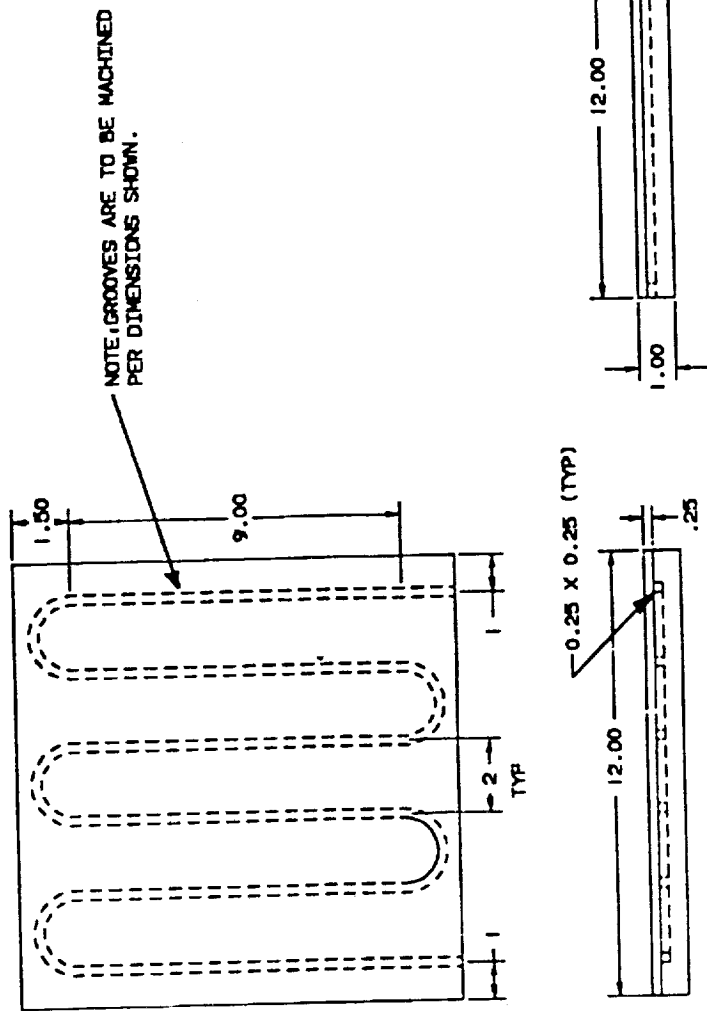

FIGURE 1 - NO SCALE

SHEAR BOX MODIFICATIONS
(UPPER HALF)

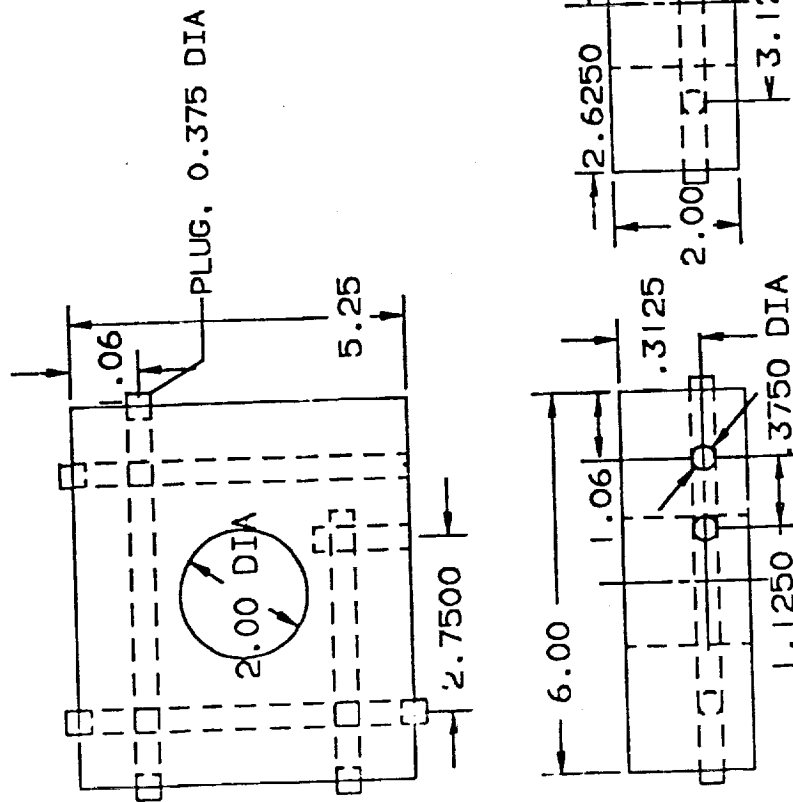

FIGURE 2

ORIGINAL PAGE IS
OF POOR QUALITY

VACUUM CHAMBER SETUP

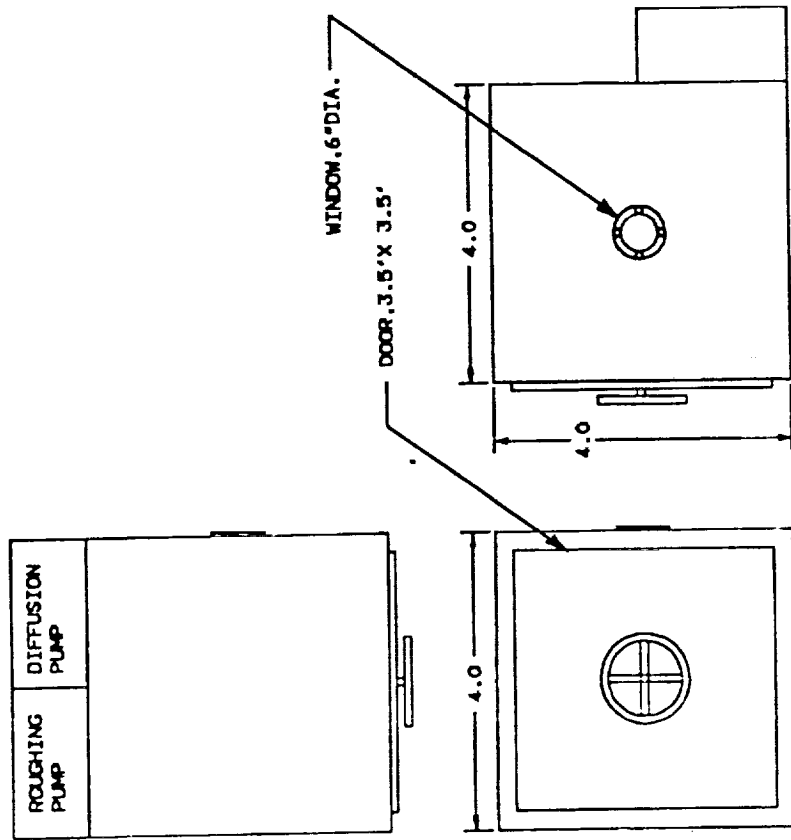
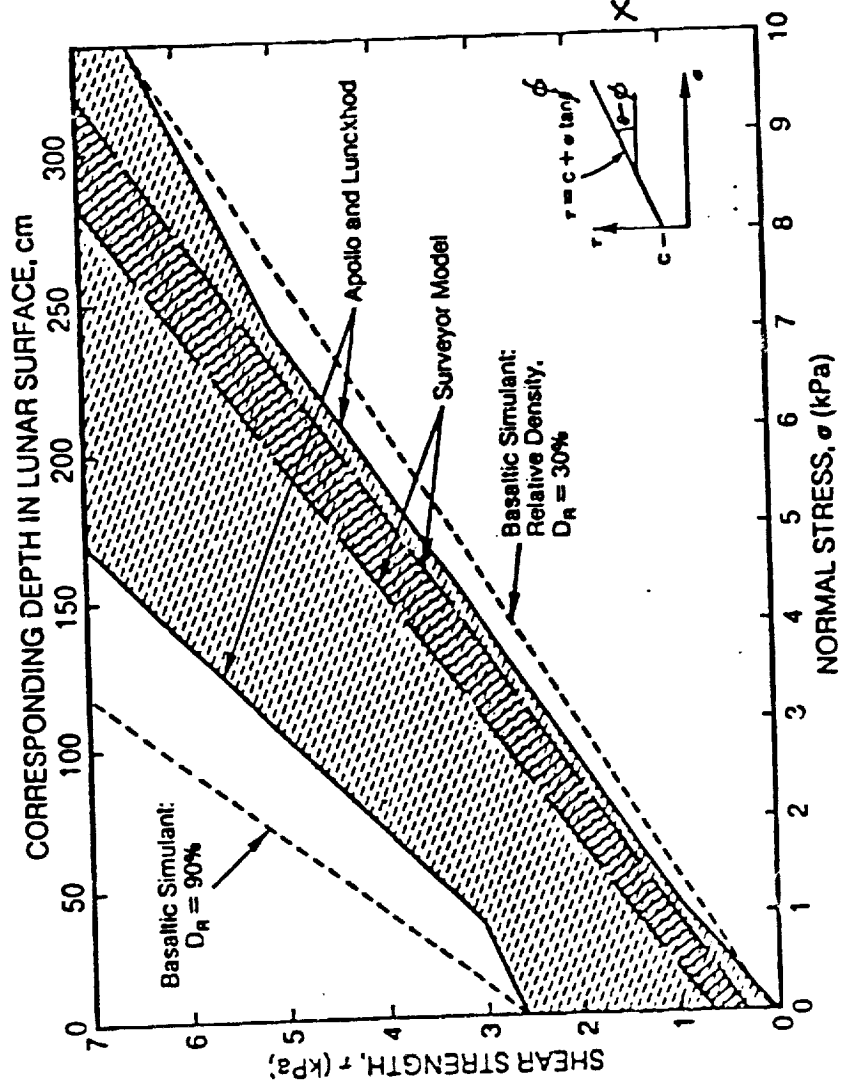

FIGURE 3 - NO SCALE

ORIGINAL PAGE IS
OF POOR QUALITY.



$\sigma \tan \phi$

In Situ Shear Strength of Lunar Soil
 (after Mitchell et al., 1974)

FIGURE 4

SOURCE: DAVID CARRIER III - ROUGH MANUSCRIPT OF A TO BE PUBLISHED BOOK 1987

ORIGINAL PAGE IS OF POOR QUALITY

USE OF DATA FROM DIRECT SHEAR TEST

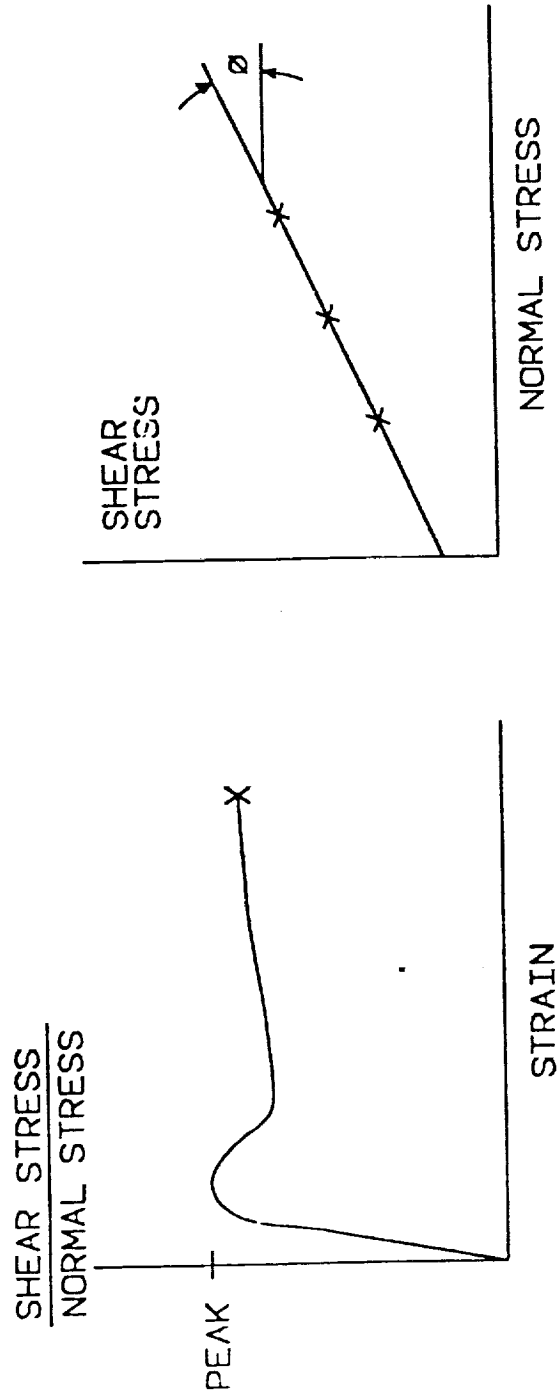

FIGURE 5

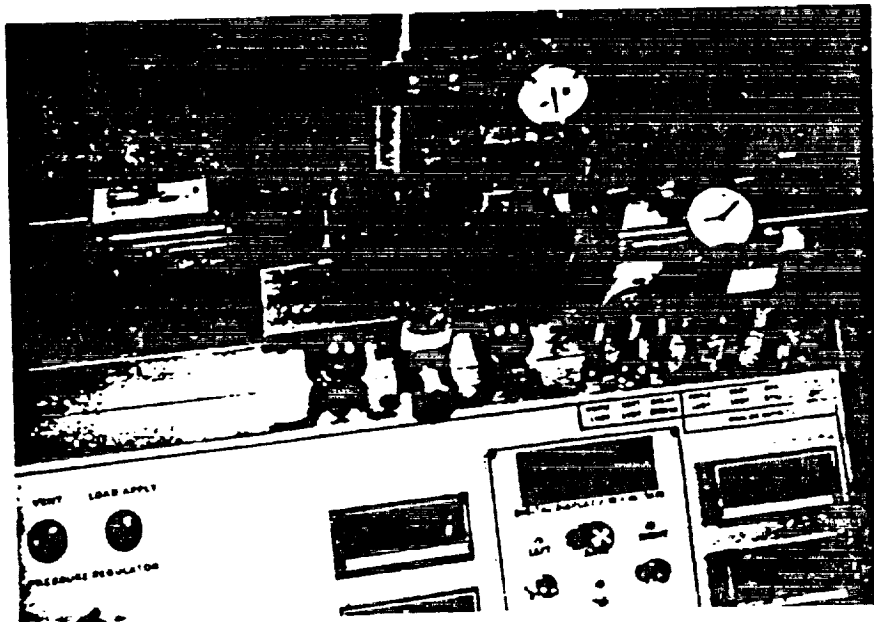
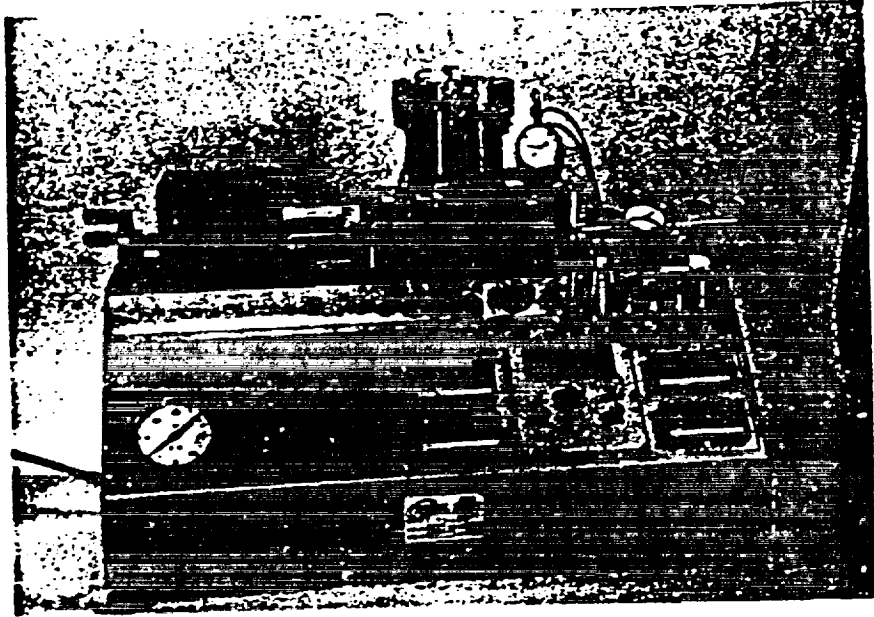

FIGURE 6

ORIGINAL PAGE IS
OF POOR QUALITY

PENETROMETER SETUP

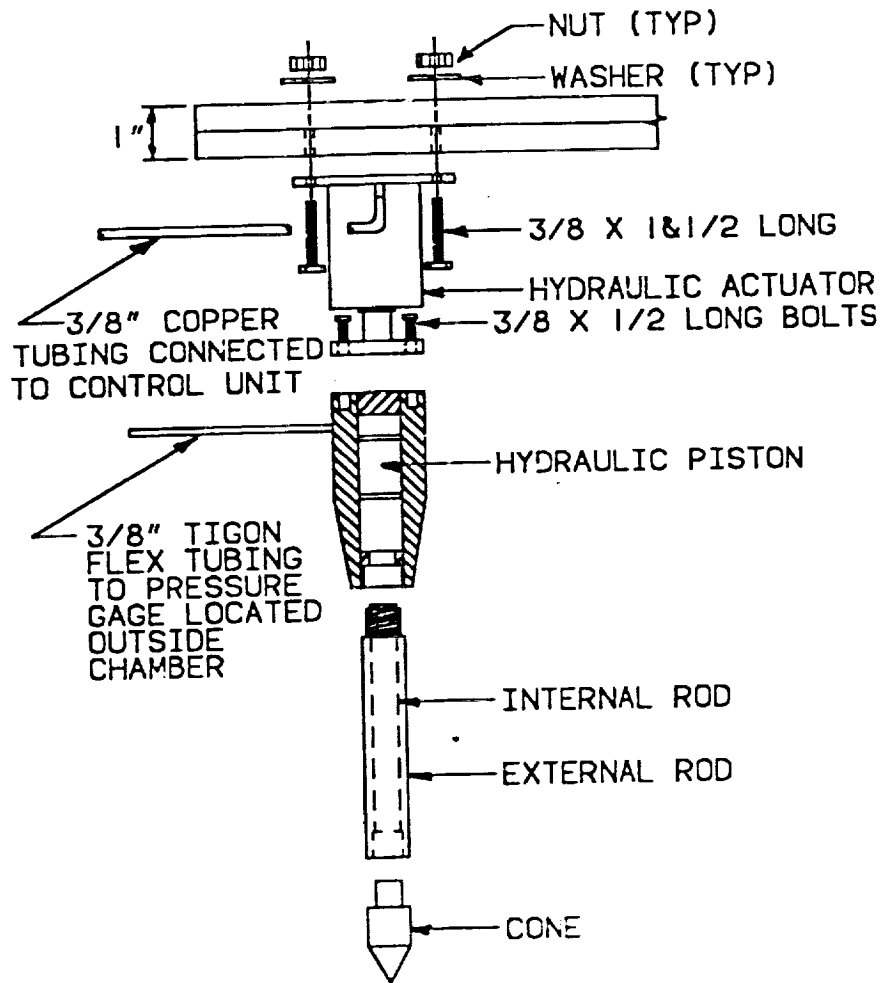

FIGURE 7 - NO SCALE

PENETROMETER TEST APPARATUS

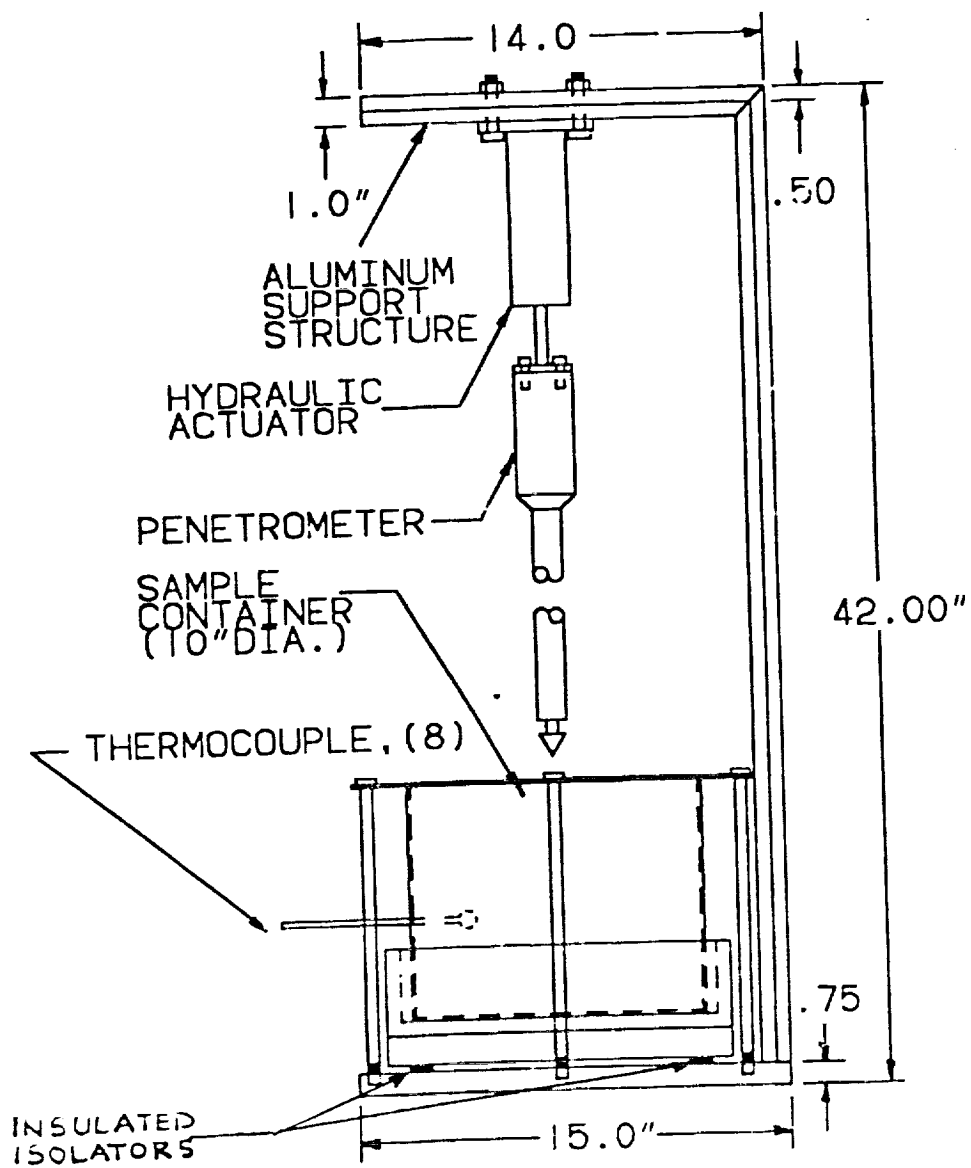

FIGURE 8 - NO SCALE

CONTROL PANEL

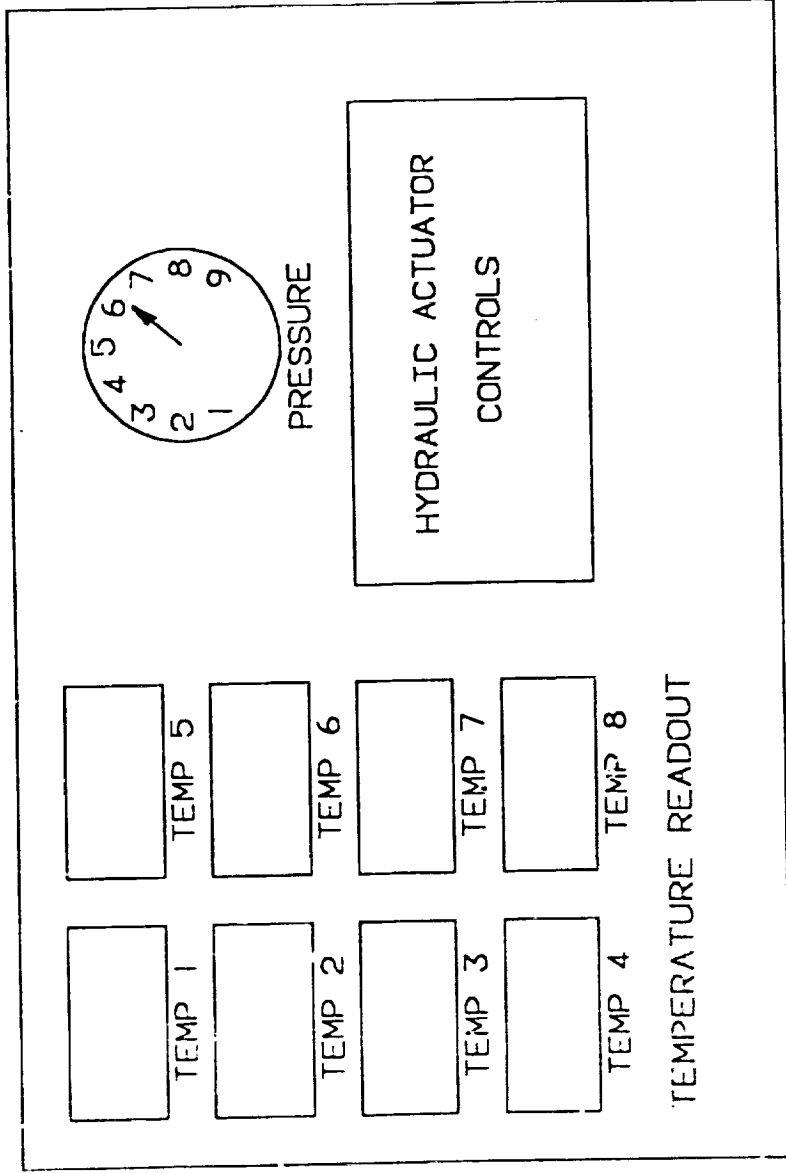

FIGURE 9 - NO SCALE

CONE DEPTH VS. RESISTANCE

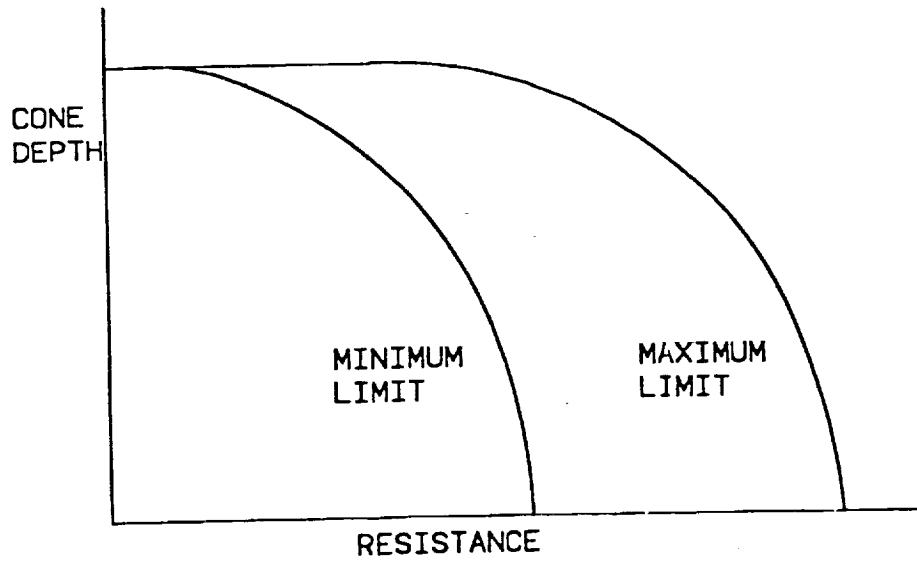

FIGURE 10

APPENDIX B
SAMPLE CALCULATIONS

ORIGINAL PAGE IS
OF POOR QUALITY

Sample Calculations

* Vacuum Outgassing *

Use basic formula $S_n = \frac{Q}{P}$

Since other parameters of system are as yet unknown, the estimate that $S_n = .40 S_p$ is considered safe.

$$\therefore S_n P = Q$$

where $Q =$ outgassing coefficient \times area

$P =$ final pressure

$S_n = .40 \times$ rated speed of pump

$$Q_{steel} = 124 \text{ sq. ft. of steel} \times 10^{-5} \text{ torr Liters/sec}$$

$$P = 10^{-6} \text{ torr}$$

$$S_n = 17,500 \text{ L/sec} \times .40 = 7,000 \text{ L/sec}$$

$$Q_{scitsim} = .349 \text{ ft}^2 \cdot 3.15 \times 10^{-1} \text{ torr} \cdot \text{L/sec}$$

$$7,000 \text{ L/sec} \cdot 10^{-6} \text{ torr} = \frac{124 \times 10^{-5} \text{ torr} \cdot \text{L/sec}}{t}$$

$$+ \frac{(3.15 \times .349) \times 10^{-1} \text{ torr} \cdot \text{L/sec}}{t}$$

* Q 's placed over t because they are linearly related to time

$$7 \times 10^{-3} = \frac{1.24 \times 10^{-3}}{t} + \frac{1.099 \times 10^{-1}}{t}$$

$$7t = 1.24 + 109.9$$

$$t = 15.87 \approx 16 \text{ hrs.}$$

Calculations

1. This calculation is intended to show that the method for heating and cooling the sample will work. The ~~times~~ times obtained are not intended to be firm experimental procedure.

Assumptions

- A. The resistance of the bronze shear box is such that the inside surface of the box is approximately the temperature of the fluid.



$$\frac{T - T_s}{T_\infty - T_s} = \text{erf} \left[\frac{r}{2\sqrt{\alpha t}} \right]$$

where :

T = temperature at centre of sample

T_s = temperature of fluid

T_∞ = ambient temperature, 65°F

r = 0.0254 m or 1 inch

t = time in seconds center to reach $\pm 200^\circ\text{F}$

α = thermal diffusivity

Cooling

$$T_s = -330^\circ\text{F}$$

$$\frac{-200 + 330}{65 + 330} = \text{erf} \left[\frac{0.0254}{2[(1 \times 10^{-7})(t)]^{1/2}} \right]$$

thus: $0.329 = \text{erf} [\quad]$

$$t = \frac{1}{(1 \times 10^{-7}) \left[\frac{0.60}{0.0254} \right]^2} = 17921 \text{ seconds}$$

$$= 4.98 \text{ hours}$$

Heating

steam at 280°F

$$\frac{200 - 280}{65 - 280} = 0.379$$

$$t = \frac{1}{(1 \times 10^{-7}) \left(\frac{0.68}{0.0254} \right)^2} = 3.9 \text{ hours.}$$

CALCULATION OF BEARING CAPACITY

The bearing capacity can be determined by the following formula:

$$q_c = F/A \quad \text{Where:}$$

q_c = Bearing capacity

F = Force read from cage

A = Area of cone tip

SAMPLE CALCULATIONS

$$F = 50 \text{ Kg}$$

$$A = 1.5 \text{ cm}^2$$

$$q_c = F/A = 50 \text{ Kg} / 1.5 \text{ cm}^2 = 33.3 \text{ Kg/cm}^2$$

$$q_c = 33.3 \text{ Kg/cm}^2$$

CALCULATION OF PENETRATION STRESS

The penetration stress can be determined from the following formula:

$$\tau_p = NS \quad \text{where:}$$

τ_p = Penetration stress

N = Constant (dependant upon type of soil)

S = Shear strength

SAMPLE CALCULATIONS

$N = 7$ for cohesionless soil

$$S = 50 \text{ kg/cm}^2$$

$$\tau_p = NS = (7)(50 \text{ kg/cm}^2) = 350 \text{ kg/cm}^2$$

$$\tau_p = 350 \text{ kg/cm}^2$$

CALCULATION OF WORK DONE

The work done on the penetrometer can be determined by the following formula:

$$\Delta W = \Delta x \tau_p A \text{ where:}$$

ΔW = Work done

Δx = Penetration depth

τ_p = Penetration stress

A = Area of cone tip

SAMPLE CALCULATIONS

$$\Delta x = 3 \text{ cm}$$

$$\tau_p = 350 \text{ kg/cm}^2$$

$$A = 1.5 \text{ cm}^2$$

$$\begin{aligned} \Delta W &= \Delta x \tau_p A = (3 \text{ cm})(350 \text{ kg/cm}^2)(1.5 \text{ cm}^2) \\ &= 1575 \text{ kg} \cdot \text{cm} \end{aligned}$$

$$\boxed{\Delta W = 1575 \text{ kg} \cdot \text{cm}}$$

Force Analysis

The maximum force that the penetrometer can withstand before failing is 1200 lbs. This force was used to determine the capacity of the hydraulic actuator. The actuator chosen was a double action in which fluid flow is shifted to achieve both hydraulic lifting and return. The capacity of actuator is one-half ton or 1000 lbs and can be purchased from Victor Fluid Power. The width of the aluminum support member was determined from the width of the actuator's base which is 5".

Deflection Analysis

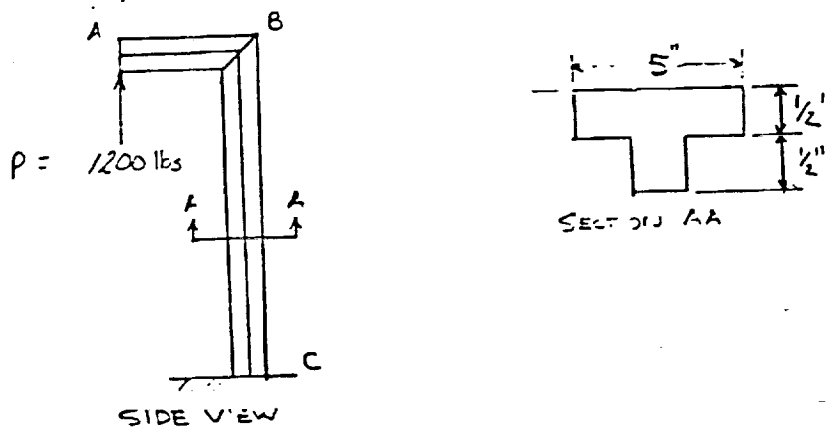

The member must not deflect more than 0.01 inches. In order to avoid exceeding this deflection limit, the thickness of the material must be determined. The strain energy function is a scalar function. Therefore, the separate strain energies for the different elastic systems can be added algebraically. After the total strain energy is determined, its partial derivative with respect to a force gives the displacement of that force.

From A to B:

$$M = Px \quad \text{and} \quad \frac{\partial M}{\partial P} = x$$

From B to C:

$$M = \frac{PL}{3} \quad \text{and} \quad \frac{\partial M}{\partial L} = \frac{1}{3}$$

$$\begin{aligned}\Delta A &= \frac{\partial U}{\partial P} = \frac{1}{EI} \int_0^{L/3} (Px)(x) dx + \frac{1}{EI} \int_0^L \left(\frac{PL}{3}\right) \left(\frac{L}{3}\right) dx \\ &= \frac{1}{EI} \left[\left(\frac{PL^3}{81} - 0\right) + \left(\frac{PL^3}{9} - 0\right) \right] \\ &= \frac{10 PL^3}{81 EI}\end{aligned}$$

To find moment of inertia we must have distance to neutral axis, therefore a web thickness of $\frac{1}{2}$ in. is chosen.

$$y_c = \frac{(5 \text{ in})(.5 \text{ in})(.25 \text{ in}) + (.5 \text{ in})(.5 \text{ in})(.75 \text{ in})}{(5 \text{ in})(.5 \text{ in}) + (.5 \text{ in})(.5 \text{ in})}$$

$$y_c = .295 \text{ in}$$

$$I_{zz} = \frac{5(.5)^3}{12} + (.5)(5)(.295)^2 + \frac{(.5)(.5)^3}{12} + (.5)(.5)(.295)^3$$

$$I_{zz} = .30 \text{ in}^4$$

For aluminum (all alloys) the Modulus of Elasticity, E is:
 $E = 10.5 \times 10^6 \text{ lbs/in}^2$

$$\Delta A = \frac{10 (1200 \text{ lbs})(3.5 \text{ in})^3}{81 (10.5 \times 10^6 \text{ lbs/in}^2)(.30 \text{ in}^4)} = .0020 \text{ in}$$

$$.0020 \text{ in} < .01 \quad \text{Requirement met}$$

APPENDIX 1
DESIGN DECISIONS

ORIGINAL PAGE IS
OF POOR QUALITY

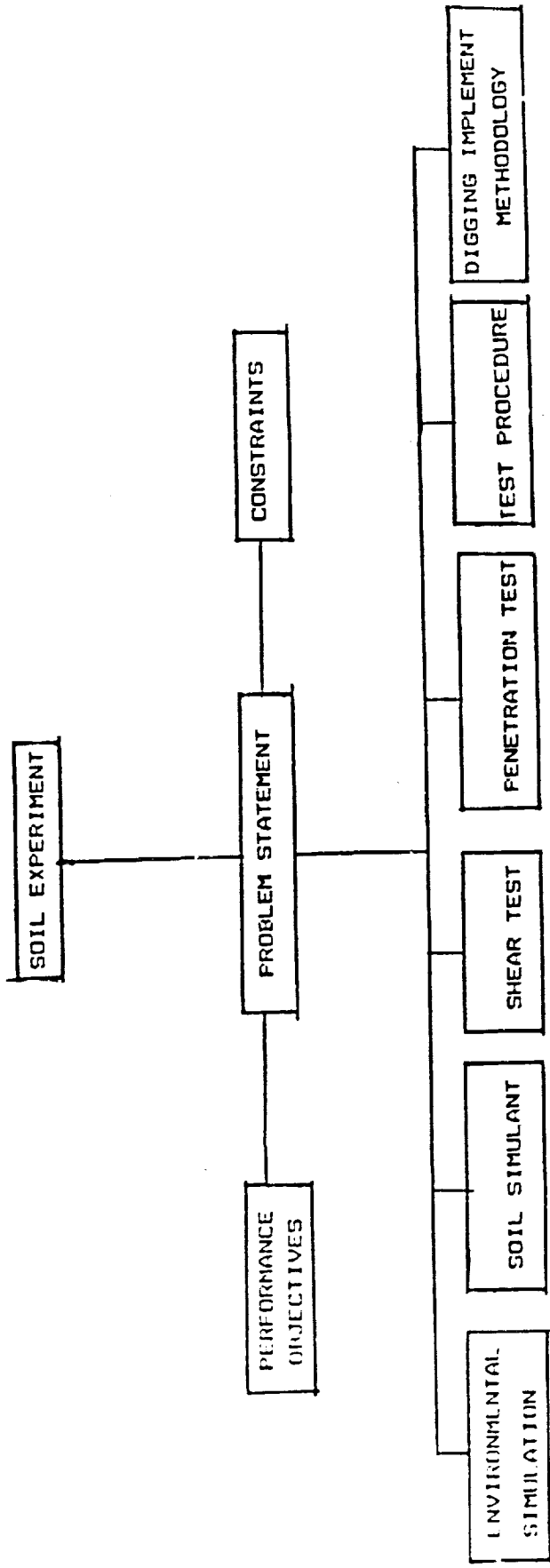

ORIGINAL PAGE IS
OF POOR QUALITY

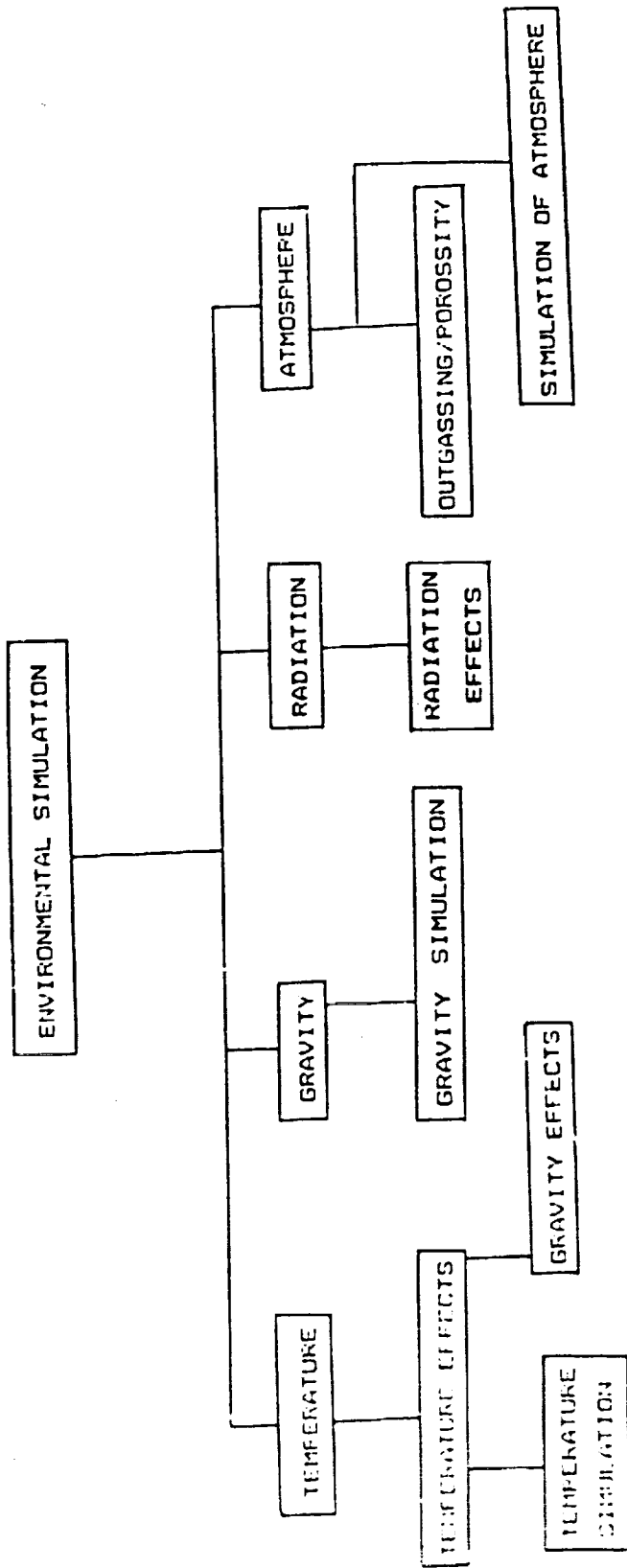

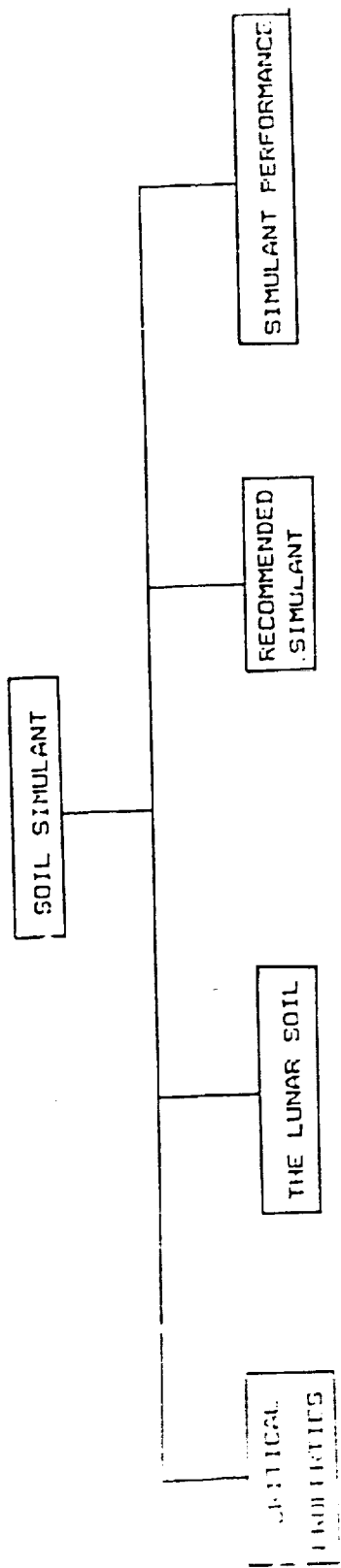

ORIGINAL PAGE IS
OF POOR QUALITY.

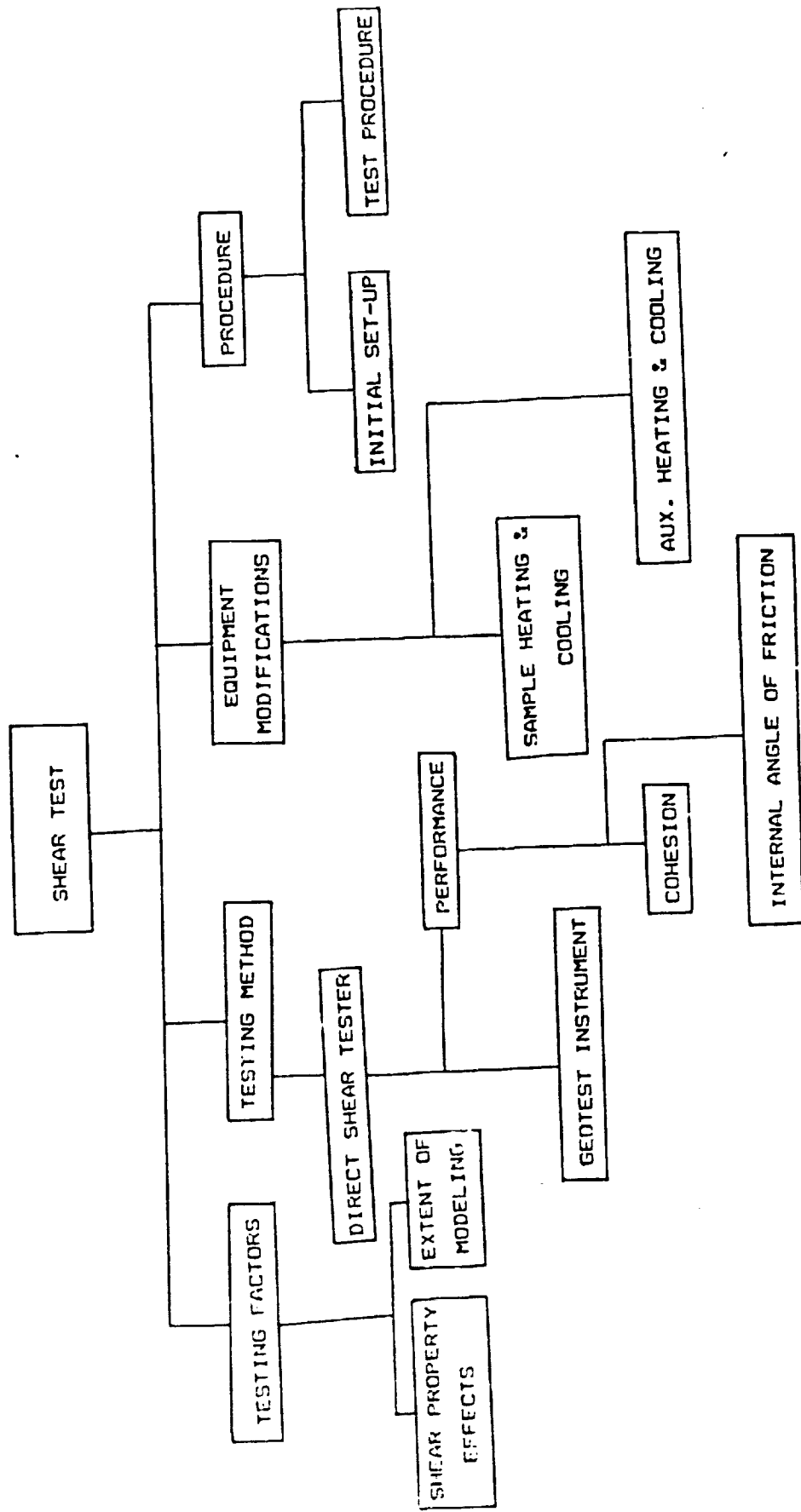

11-11-11 11:11:11

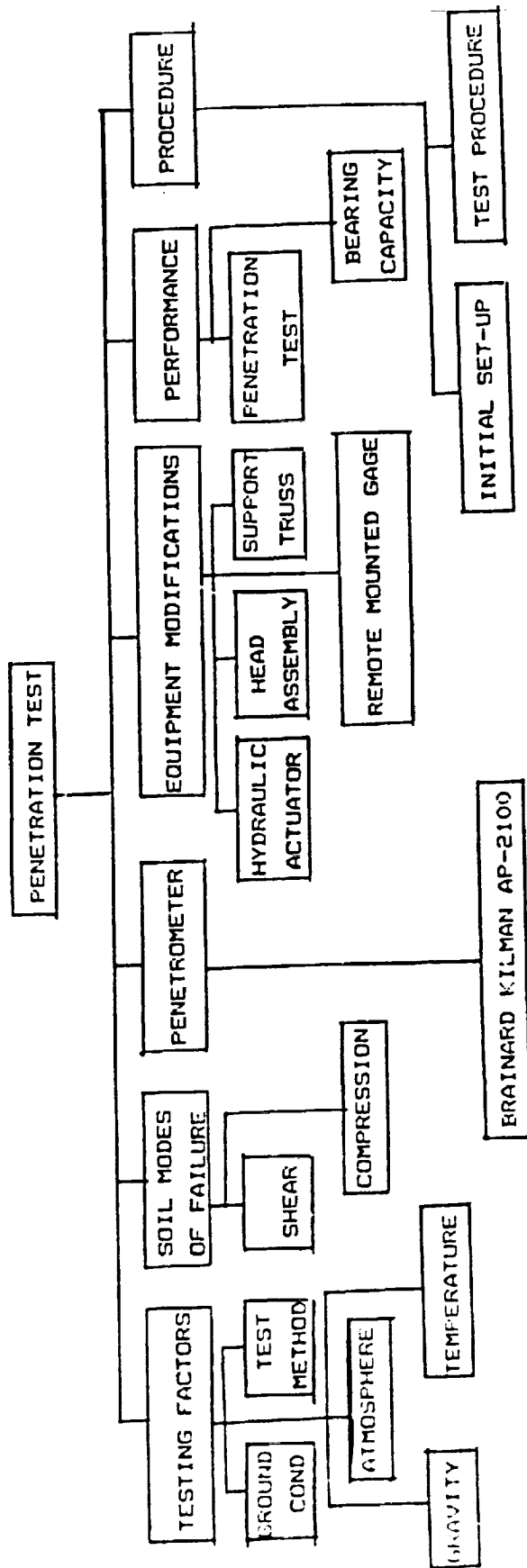

ORIGINAL PAGE IS
OF POOR QUALITY

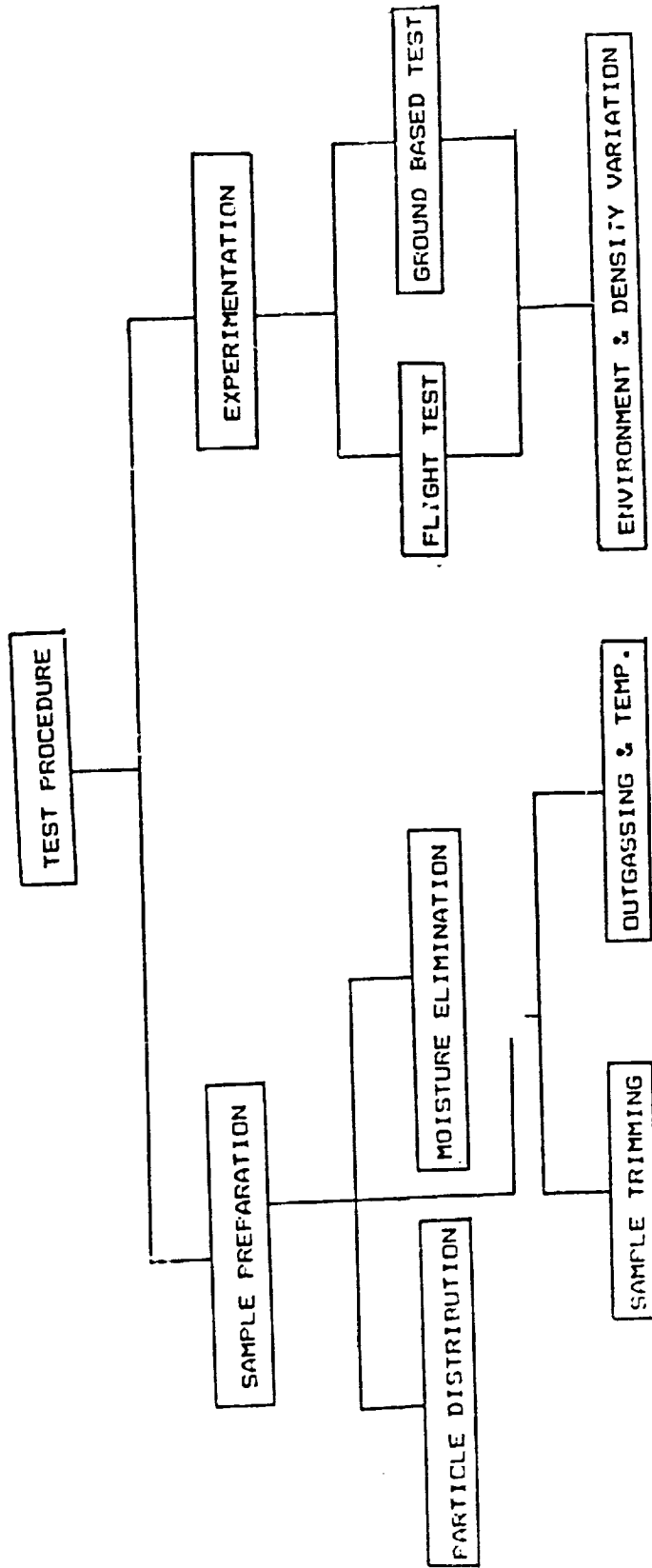

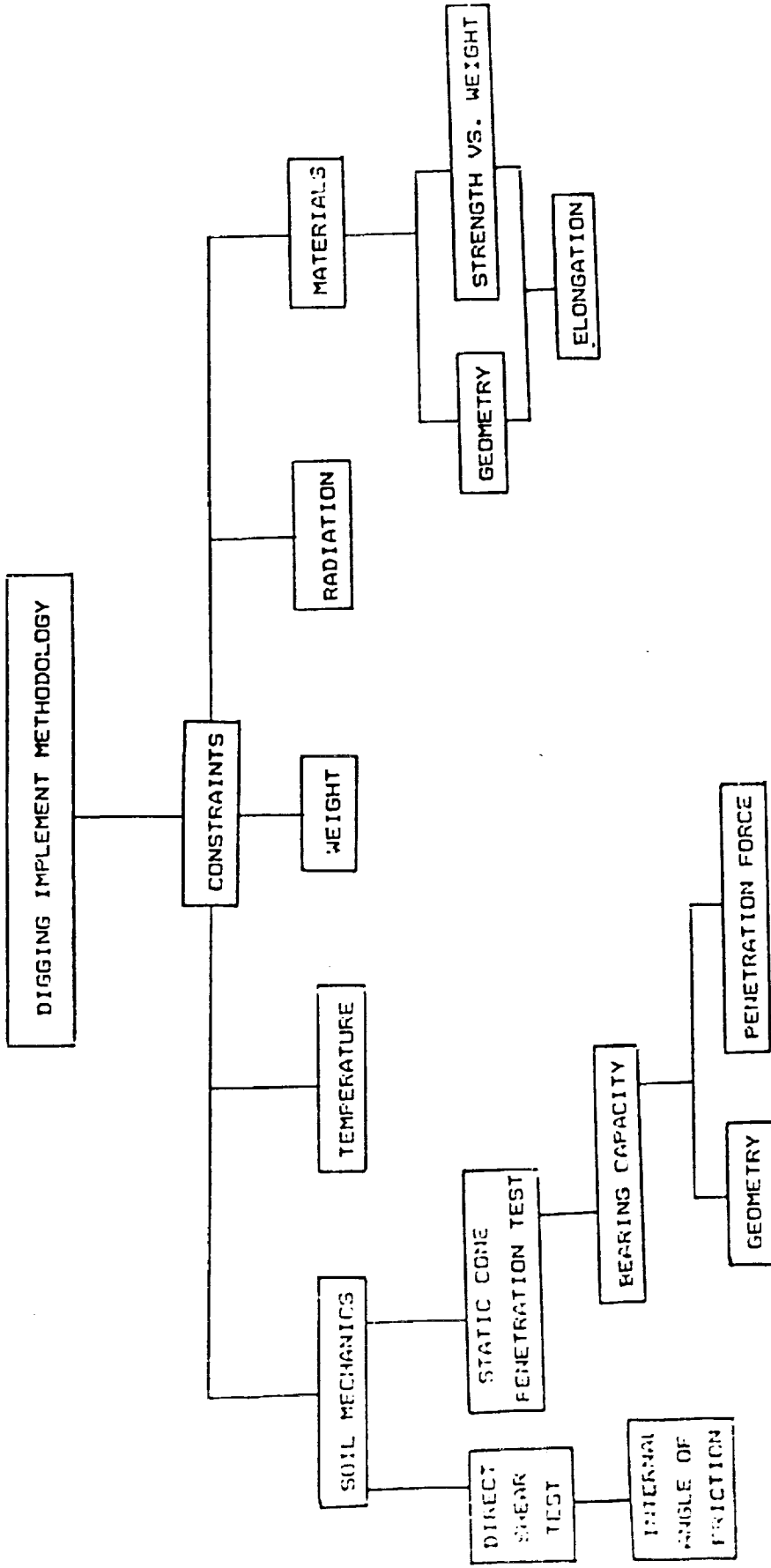

APPENDIX
AFTER MARKET EQUIPMENT

ORIGINAL PAGE IS
OF POOR QUALITY

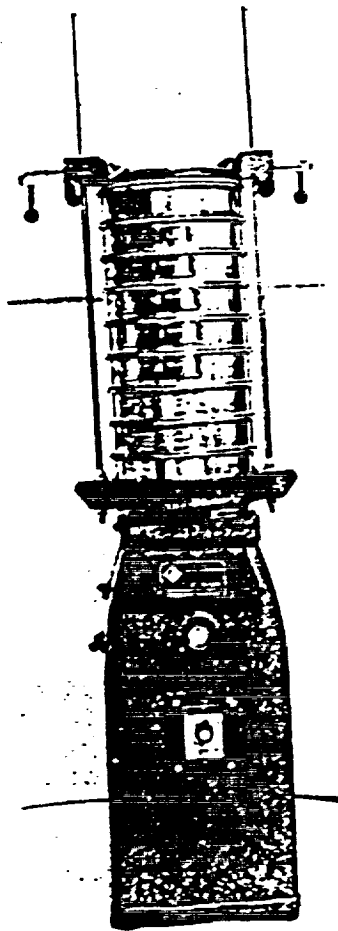

Fig. 126 Sieve shaker, Inclyno type

ORIGINAL PAGE IS
OF POOR QUALITY

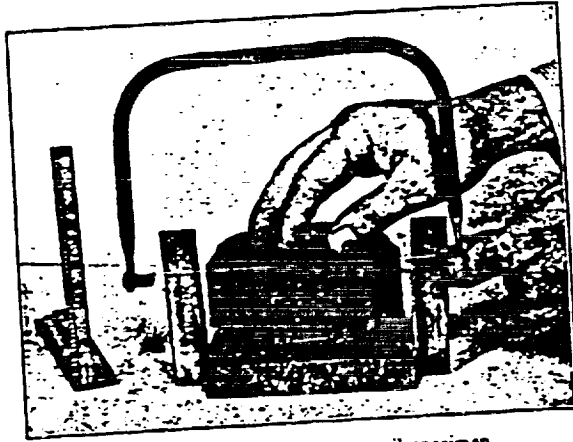

FIGURE LX-7. Trimming a soil specimen.

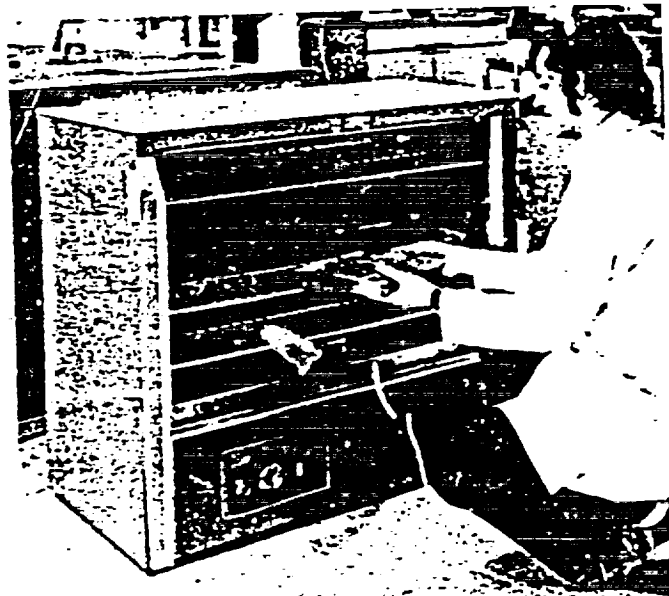
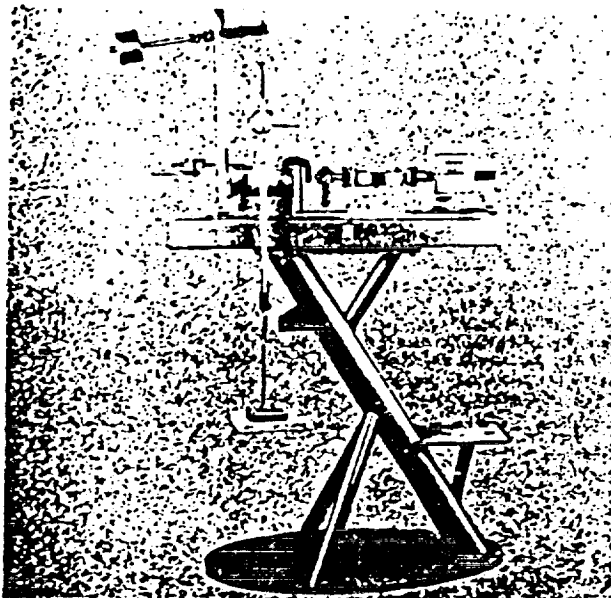

Fig 1.10 Large-capacity electric drying oven

ORIGINAL PAGE IS
OF POOR QUALITY

SOIL/Direct Shear



Hand Operated Direct Shear Apparatus

Function

Applies vertical load and manually applies horizontal load to sample to measure shear strength.

Testing Standards

ASTM D-3080

Specifications

Sample Sizes	2 x 2 square or 2-1/2 diam
Shearing Force	1500 lb capacity
Shear Loading	Hand operated crank through gear box
Shear Measurement	500 lb double proving ring with dial indicator
Shear Box	Bronze split horizontally
Vertical Load	350 lb capacity counterbalanced system
Strain Measurement	Dial indicator 1 000 x 0.001
Speed Measurement	Dial indicator 1 000 x 0.001
Weights	Two 1-kg and two 4-kg
Frame	Welded steel enamel finish
Dimensions	24 w x 26 l (floor space)

Models

Includes specimen cutter and supply of data sheets

D-110A. For 2' x 2' samples

D-110B. For 2-1/2 diam samples

Weights

Net 165 lbs. Shpg 250 lbs

Accessories/Options

LC-12. Metric Dial Indicator. Clockwise. 25 mm x 0.01 mm

LC-13. Metric Dial Indicator. Counterclockwise. 25 mm x 0.01 mm

Replacement Parts

D-181 Shear Box Housing. Net Wt 8 lbs. Shpg Wt 10 lbs.

D-182 Direct Shear Box 2-1/2 diam. Net Wt 4 lbs. Shpg Wt 10 lbs.

D-183 Direct Shear Box 2 x 2. Net Wt 7 lbs. Shpg Wt 10 lbs.

D-184 Gripper Assembly. For 2-1/2 diam samples. Net Wt 4 lbs. Shpg Wt 6 lbs.

D-188 Bronze Porous Plate Set 2-1/2 diam. set of two for D-184 Gripper Assembly. Net Wt 1/2 lb. Shpg Wt 1 lb.

D-185 Gripper Assembly. For 2 x 2 samples. Net Wt 4 lbs. Shpg Wt 6 lbs.

D-186 Specimen Cutter. For 2-1/2 diam x 1 thick samples. Net Wt 1/2 lb. Shpg Wt 1 lb.

D-187 Square Specimen Cutter. For 2 x 2 x 3-4 thick samples. Net Wt 1/2 lb. Shpg Wt 1 lb.

D-190 Shear Box Coupling. Net Wt 1/2 lb. Shpg Wt 1 lb.

WS-1. 1 kg Weight.

WS-4. 4 kg Weight.

DS-12. Cohesive Materials Data Sheets. Pkg of 100

DS-13. Cohesionless Materials Data Sheets. Pkg of 100

LC-8. Dial Indicator. Clockwise. 1 000 x 0.001"

LC-9. Dial Indicator. Counterclockwise. 1 000 x 0.001"

Direct Shear Conversion Set

Function

Converts Hand Operated Direct Shear Apparatus (D-110 Series) to motorized type.

Models

Includes motorized transmission unit, sprockets, chain and connecting links,

chain guard, reversing and other controls, and assembly drawing.

D-125. 110v AC. 60 Hz. 1p

D-125-4. 220v AC. 50/60 Hz. 1p

Weights

Net 155 lbs (70.3 kg). Shpg 200 lbs (90.7 kg)

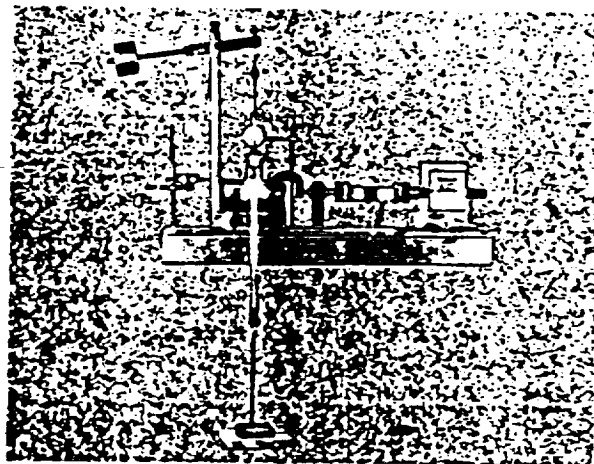

Table Model Direct Shear Apparatus

Function

Applies vertical load and manually applies horizontal load to sample to measure shear strength.

Testing Standards

ASTM D-3080

Specifications

Same as D-110 Series except

Installation. For table or bench, all parts mounted on 6" wide base in lieu of lower frame.

Models

D-130A. For 2 x 2 samples

D-130B. For 2-1/2 diam samples

Weights

Net 135 lbs. Shpg 160 lbs

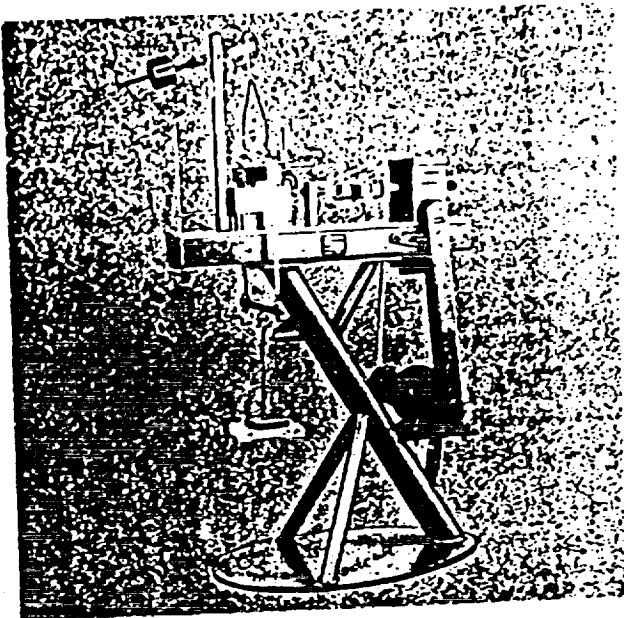

Motorized Direct Shear Apparatus

Function
Applies vertical and horizontal loads to sample to measure shear strength

Testing Standards
ASTM D-3080

Specifications

Sample Sizes	2" x 2" square or 2-1/2" diam.
Shearing Force	1500 lb capacity
Shear Loading	Variable speed, electric gear transmission drive, strain rate 0.015 to 0.45/min
Shear Measurement	500 lb double proving ring with dial indicator
Shear Box	Bronze, soft horizontally
Vertical Load	D-120 Series 350 lb capacity, counterbalanced system D-124 Series 1500 lb capacity, counterbalanced lever system, 8:1 lever ratio
Strain Measurement	Dial indicator, 1.000" x 0.001"
Swell Measurement	Dial indicator, 1.000" x 0.001"
Weights	Two 1-kg and two 4-kg
Frame	Welded steel, enamel finish
Dimensions	21" w x 34" l (floor space)

Models

Includes specimen cutter and supply of data sheets.

350 lb. vertical load capacities:

- D-120A. For 2" x 2" samples 110v AC, 60 Hz, 1ϕ.
 - D-120A-4. For 2" x 2" samples 220v AC, 50/60 Hz, 1ϕ.
 - D-120B. For 2-1/2" diam. samples 110v AC, 60 Hz, 1ϕ.
 - D-120B-4. For 2-1/2" diam. samples 220v AC, 50/60 Hz, 1ϕ.
- 1500 lb. vertical load capacities:
- D-124A. For 2" x 2" samples 110v AC, 60 Hz, 1ϕ.
 - D-124A-4. For 2" x 2" samples 220v AC, 50/60 Hz, 1ϕ.
 - D-124B. For 2-1/2" diam. samples 110v AC, 60 Hz, 1ϕ.
 - D-124B-4. For 2-1/2" diam. samples 220v AC, 50/60 Hz, 1ϕ.

Weights

- D-120 Series Net 260 lbs (118.2 kg)
- D-124 Series Net 290 lbs (131.8 kg)

Accessories/Options

- LC-12. Metric Dial Indicator. Clockwise, 25 mm range x 0.01 mm graduations
- LC-13. Metric Dial Indicator. Counterclockwise, 25 mm range x 0.01 mm graduations

Replacement Parts

- D-181. Shear Box Housing. Net Wt 8 lbs, Shpg Wt 10 lbs
- D-182. Direct Shear Box. 2-1/2" diam. Net Wt 4 lbs, Shpg Wt 10 lbs
- D-183. Direct Shear Box. 2" x 2". Net Wt 7 lbs, Shpg Wt 10 lbs
- D-184. Gripper Assembly. For 2-1/2" diam. samples. Net Wt 4 lbs, Shpg Wt 6 lbs
- D-188. Bronze Porous Plate Set. 2-1/2" diam., set of two for D-184 Gripper Assembly. Net Wt 1/2 lb, Shpg Wt 1 lb
- D-185. Gripper Assembly. For 2" x 2" samples. Net Wt 4 lbs, Shpg Wt 6 lbs
- D-186. Specimen Cutter. For 2-1/2" diam x 1" thick samples. Net Wt 1/2 lb, Shpg Wt 1 lb
- D-187. Square Specimen Cutter. For 2" x 2" x 3/4" thick samples. Net Wt 1/2 lb, Shpg Wt 1 lb
- D-190. Shear Box Coupling. Net Wt 1/2 lb, Shpg Wt 1 lb
- WS-1. 1 kg Weight.
- WS-4. 4 kg Weight.
- DS-12. Cohesive Materials Data Sheets. Pkg. of 100.
- DS-13. Cohesionless Materials Data Sheets. Pkg. of 100.
- LC-8. Dial Indicator. Clockwise, 1.000" x 0.001".
- LC-9. Dial Indicator. Counterclockwise, 1.000" x 0.001".

SOIL/Direct Shear

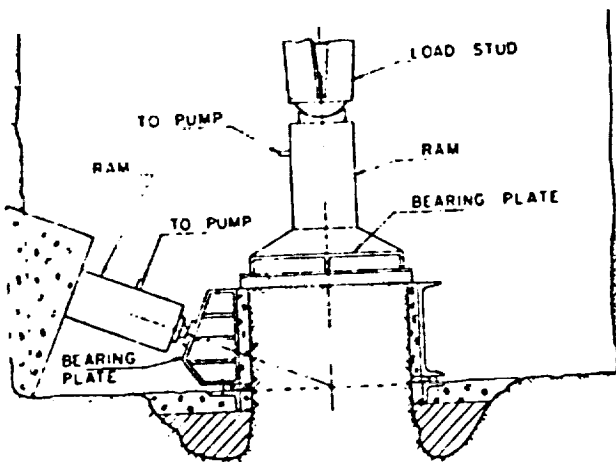

Field Direct Shear Set

Function

High loading capacity for in-place shear testing of rock blocks, massive soil samples and for special bearing applications in excavations, tunnels and test pits.

Specifications

Hydraulic Ram	8" diam
Stroke	3"
Electric Pump	3/4 h.p. 1100 watts

Models

Set includes 2 Hydraulic Loading Rams with gauges
1 Two-Speed, Manual Concentric Piston Pump
1 Variable Speed Electric Pump
2 Hoses, 12' L
2 Spherical Bearing Attachments
D-160, 400,000 lb. Loading Rams, 110v AC, 60 Hz, 1p.
D-160-S, 400,000 lb. Loading Rams, 220v AC, 50 Hz, 1p.
D-160M, Metric, 180,000 kg Loading Rams, 110v AC, 60 Hz, 1p.
D-160M-S, Metric, 180,000 kg Loading Rams, 220v AC, 50 Hz, 1p.

Weights

Net 620 lbs. (372 kg). Shpg. 920 lbs. (417.3 kg)

Special Note

Bearing plates not included, order separately according to local testing program requirements.

Need product or help in a hurry?
In Continental U.S. (excluding Illinois), Puerto Rico, St. Thomas, St. John, and St. Croix, dial toll-free:

1-800-323-1242

In Illinois, dial:

1-800-942-3374



Shear Box Housing

Function

Contains shear box and water to test saturated sample in Direct Shear Apparatus (Model Series D-110, D-120, D-124 and D-130).

Specifications

Construction	Machined cast bronze
Base	With mounting holes
Shear Boxes	Accommodates 2-1/2 diam and 2 x 2 sizes

Models

D-181.

Weights

Net 8 lbs.; Shpg. 10 lbs.

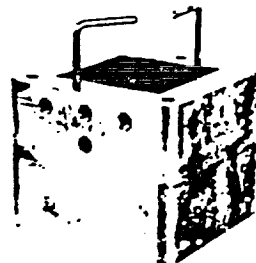

Direct Shear Box

Function

Contains and shears soil sample in Direct Shear Apparatus (Model Series D-110A, D-120A, D-124A and D-130A).

Specifications

Sample Size	2 x 2 x 3/4 thick
Centering Pins	Align upper and lower box sections

Models

D-183.

Weights

Net 7 lbs.; Shpg. 10 lbs.



Direct Shear Box

Function

Contains and shears soil sample in Direct Shear Apparatus (Model Series D-110B, D-120B, D-120B, D-124B and D-130B).

Specifications

Sample Size	2-1/2" diam. x 1" thick
Construction	Upper and lower rings of machined bronze
Centering Pins	Align upper and lower rings

Models

D-182.

Weights

Net 4 lbs.; Shpg. 10 lbs.



Spare Gripper Assembly

Function

Holds top and bottom of soil sample in Model D-182 Shear Box during shear testing and allows water to pass.

Specifications

Sample Size	2-1/2" diam.
Porous Stones	In upper and lower sections, with brass gripping strips
Upper Section	Recessed to receive and align loading yoke

Models

D-184.

Weights

Net 4 lbs.; Shpg. 6 lbs.

Replacement Parts

D-188. Bronze Porous Plate Set. With brass gripping strips. Net Wt. 1/2 lb.; Shpg. Wt. 1 lb.

ORIGINAL PAGE IS
OF POOR QUALITY



Spare Gripper Assembly

Function
Holds top and bottom of soil sample in Model D-183 Shear Box during shear testing and allows water to pass

Specifications

Sample Size	2" x 2" square
Porous Stones	In upper and lower sections with brass gripping strips
Upper Section	Recessed to receive and align loading yoke

Models

D-185.

Weights

Net 4 lbs., Shpg. 6 lbs



Specimen Cutters

Function
Cut soil sample to size of shear box.

Models
D-186. For 2-1/2" diam. x 1" thick samples. Machined steel.
D-187. For 2" x 2" x 3/4" thick samples. Machined brass

Weights

Net 1/2 lb.; Shpg. 1 lb.

Shear Box Coupling

Function
Transfers shearing load from proving ring to shear box in Direct Shear Apparatus (Model Series D-110, D-120, D-124 and D-130).

Models

D-190. Cast aluminum construction.

Weights

Net 1/2 lb., Shpg. 1 lb.

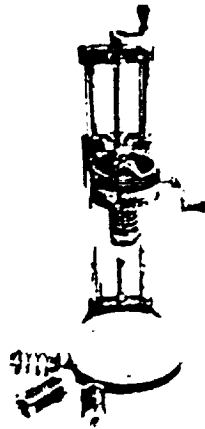

Laboratory Vane Tester

Function
Measures shear strength of sample in mold by rotating inserted fins until failure

Specifications

Sample Size	Accommodates standard sample molds and tubes up to 9" long
Torque Head	Adjusts 5" vertically
Torsion Springs	Four included, calibrated to torque ratings of 2, 3, 4 and 5 inch lbs through approximately 180°

Models

Note: Sample molds not included.
D-200.

Weights

Net 25 lbs. (11 kg), Shpg. 40 lbs. (19 kg).

CONTINUED



AP-2100



- Rapid selection of locations for field density tests
- Evaluating backfills in trenches and behind walls
- Light foundation investigations
- For rapid correlation of field CBR tests
- Earthwork control for embankments
- Muck & soft soil probes
- Probing shallow marine deposits
- Probing beneath existing shallow foundations
- Pavement subgrade evaluations

FAST AND EASY

Brainard-Kilman's new **Portable Static Cone Penetrometer** is unmatched in accuracy and ease of operation for quickly measuring soil consistency. The **Portable Static Cone Penetrometer** is specifically designed for use in fine-grained, soft soils to depths as much as 30 feet!

Operation couldn't be easier: simply force the Cone into the soil approximately 6 inches, back off until the gauge reads zero, then advance another 6 inches. Cone Stress is read directly on the conveniently mounted gauge.

NO SOIL FRICTION

The Brainard-Kilman Porta-

ble **Static Cone Penetrometer** features dual rod construction. As the inner rod functions independently of the outer rod, soil friction is not a factor with this unit. Cone Stress as read on the gauge can be easily correlated to local soil constants without having to adjust for the soil friction coefficient.

MEANT TO BE USED

Brainard-Kilman designed the

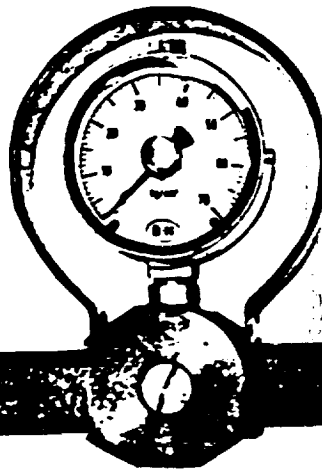

Portable Static Cone

Penetrometer to be an extremely rugged device, built for day-in, day-out use. High strength aluminum and steels were used in the design to protect and maintain the accuracy of the 0 - 70 KG/CM² Gauge.

LIGHTWEIGHT, SELF CONTAINED

The basic **Portable Static Cone Penetrometer** weighs only 5 pounds! Even with extension rods, the device is easily carried by 1 person. Totally self contained, the **Portable Static Cone Penetrometer** requires no auxiliary equipment.

BRAINARD-KILMAN

P. O. Box 1959, Stone Mtn, GA 30086
(404) 469-2720 • 1-800-241-9468



C-2

ORIGINAL PAGE IS
OF POOR QUALITY



AP-2100

SPECIFICATIONS

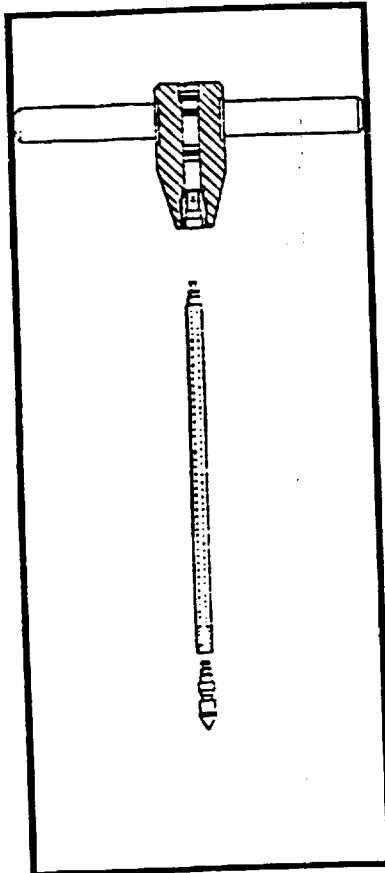

AP-2100 A

Portable Static Cone Penetrometer with 4' Rod Assembly

AP-2100 B

Portable Static Cone Penetrometer with 2.5' Rod Assembly

RANGE: Qc Max: 0-70KG/CM²
LOAD LIMIT: 250 LBS

• CONE

Material: Stainless Steel
Cone End Angle: 60°
Max. Section Area: 1.5cm²

weight 6061-T6 Aluminum.
Anodized for protection.

Stainless insert prevents rod
threads from wearing.
Smoothly finished inside
bore and piston for low fric-
tion coefficient.

• ROD ASSEMBLY

Material:
Outer Rod: High Strength
4140 Chromoly tubing
Inner Rod: Centerless
Ground 316 Stainless
Steel

• GAUGE

Size: 2.5" diameter
Range: 0 - 70 KG/CM²
Built-in gauge-zeroing ad-
justment and integral gauge
guard band

• HEAD ASSEMBLY

Material: High Strength, light

ORDERING INFORMATION

PART NO.	DESCRIPTION	PRICE
AP-2100 A	Penetrometer with 4' "starter" rod assembly	\$ 525.00
AP-2100 B	Penetrometer with 2.5' "starter" rod assembly	\$ 510.00
ACCESSORIES		
AP-2100-14	4' "extension" rod assembly	\$ 63.50
AP-2100-16	2.5' "extension" rod assembly	\$ 53.50
REPLACEMENT PARTS		
AP-2100-18	Cone Assembly	\$ 51.50
AP-2100-8	4' "starter" rod assembly	\$ 63.50
AP-2100-11	2.5' "starter" rod assembly	\$ 53.50

effective 6/15/87, prices & specifications subject to change without notice

BRAINARD-KILMAN
P.O. Box 1959, Stone Mt., GA 30086
(404)469-2720 • 1-800-241-9468



APPENDIX E
WEEKLY PROGRESS REPORT

ORIGINAL PAGE IS
OF POOR QUALITY

To: GT58128 Gary Von McMurray
From: GT29458 Malcolm Todd Butler
Date: 87/06/30. 16.49.04

Subject: Soil

To: Dr. Williams, Me 4182 Instructor.
From: Group 4
Date: 6/31/87
Group Members: Todd Butler
Charles Cline
Linton Hutcheson
Steve Scruggs
Mike Smith
Nadim Zakhia

the objective of group 4 is to design a test apparatus and procedure used to determine the mechanical properties of simulated lunar soil. we met with gary to define our objective since initially there was some confusion as to the guidelines the project was to follow. thus far, we have discussed our objective, collected literature and researched some major topics pertaining to our project. in addition to researching literature, we plan to contact various geological services in order to collect additional data which might be helpful in our research.

this progress report reflects the work of each group member on an equal basis.

SOIL EXPERIMENT

VACUUM CHAMBER

CONTROL
PANEL

SOIL
TESTING
MACHINE

DRAWING #1

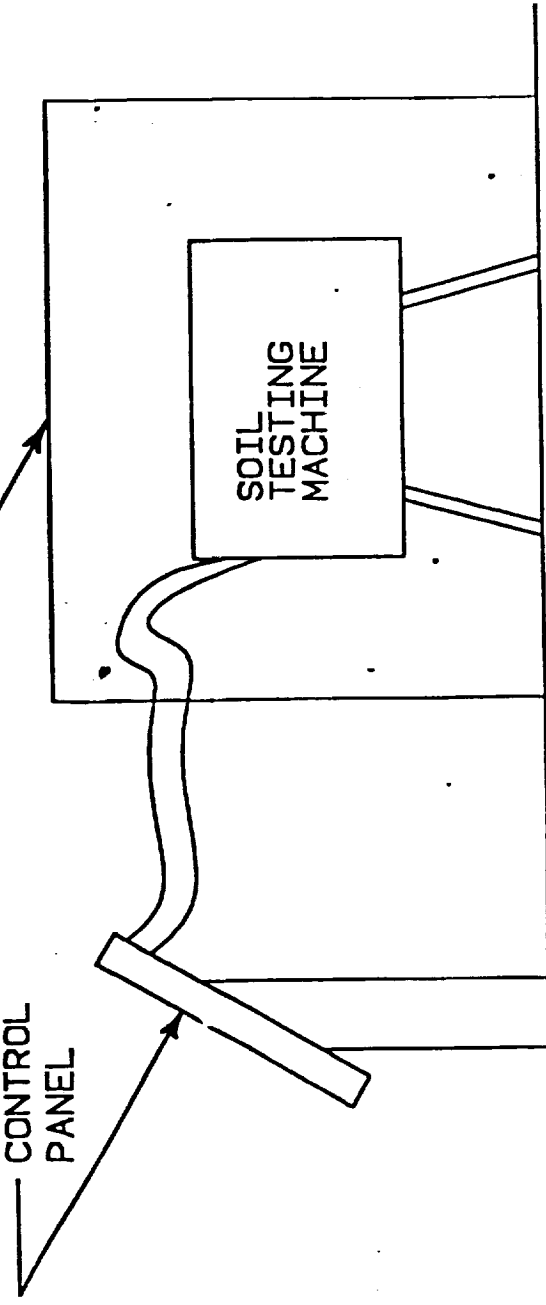

DATE: July 15. 1987

TO: Dr. Williams, ME 4182 Instructor

FROM: Group4

SUBJECT: Progress Report on the Soil Experiment

During the past week, our group has been researching various reports and data which are relevant to our study of soil mechanics. Research has been done on the types of test that would provide the most information on the physical properties of soil with the least amount of test equipment. The shear and penetration tests were selected because (1) they are relatively simple, (2) there is much available terrestrial experience with these types of tests. These tests would allow for the measurement of soil properties such as: bearing capacities, angle of internal friction, stress-strain relationships, base roughness and failure modes for local and general shear.

A meeting was held Tuesday the 14th to discuss some methods that may be used to simulate the lunar test environment. Various reports have been requested from NASA and should arrive later this week.

INDIVIDUAL INPUT:

Penetration Test: Linton, Todd
Shear Test: Mike, Steve
Vacuum Chamber: Charles, Nadim
Cad/Cam: Mike
Processing: Linton

FAILURE PATTERN UNDER A SHALLOW FOUNDATION

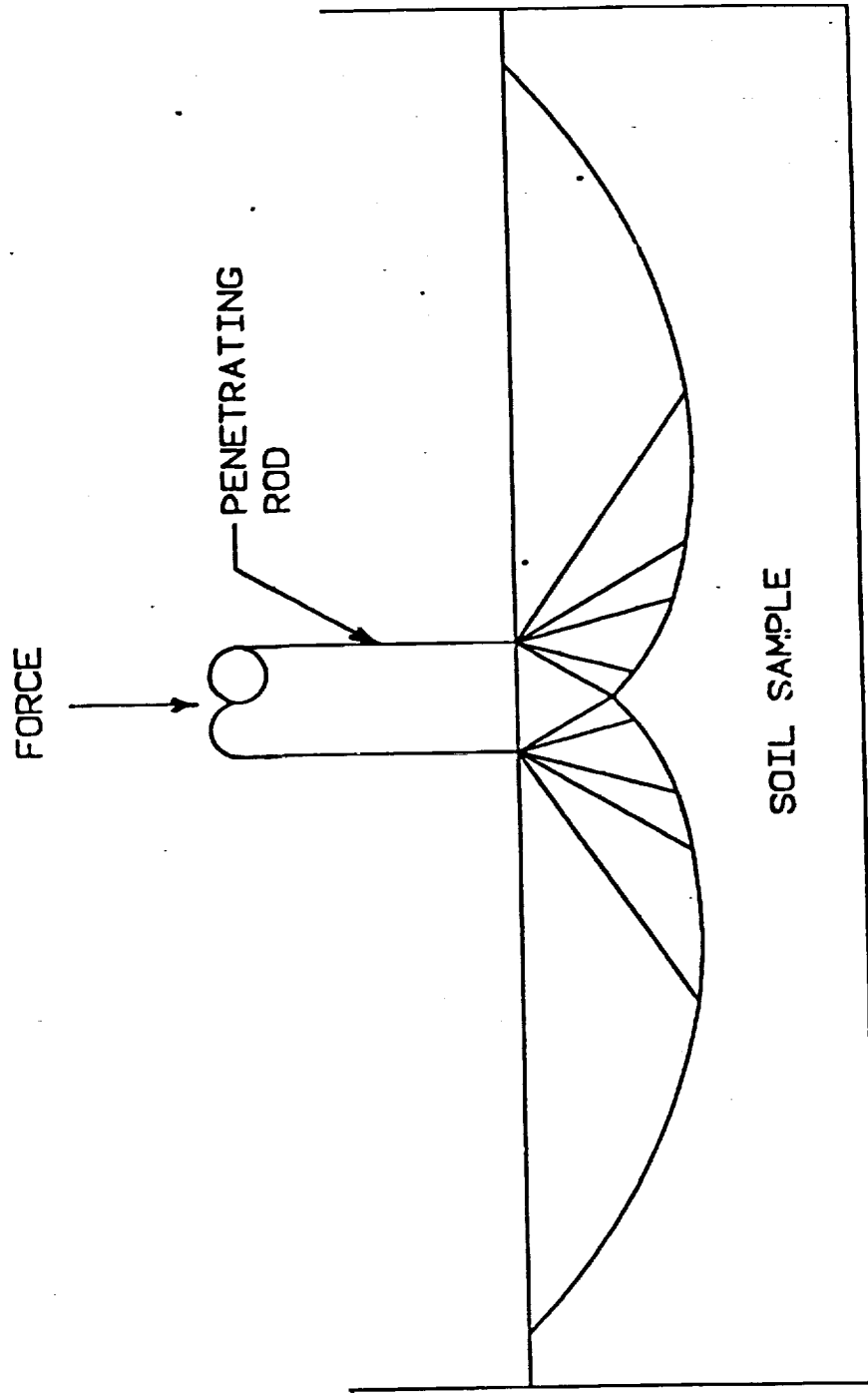

Date: July 22, 1987

TO: DR. WILLIAMS, ME 4182 INSTRUCTOR

FROM: Group 4

SUBJECT: Progress Report on Soil Experiment

This week our group has been involved in further research of the critical design parameters of the soil experiment. Various sources of information pertaining to the environmental conditions of lunar soil have been investigated. The group has determined a number of areas that are critical to the test design. Radiation has been a major subject of our research this past week. We are not yet sure how radiation will effect the soil, if at all, however we do intend to find out in the very near future. Our group is also continuing with reseach of how to best simulate the lunar environment. This seems to be one of the major problems which will have to be solved. Each member has selected one or several of the environmental conditions in order to gain "expertise" in that particular area. Each member has also been directed to submit, in written form, a summary of pertinent information on their area of expertise to Linton Hutcheson who will be giving the oral presentation next week.

As seen in the initial paragraph, our group has a general idea of what we will design, and now we are gathering concrete design criteria as well as methodology for use of a soil experiment.

INDIVIDUAL INPUT:

Soil Simulant: Charles, Nadim
Radiation: Linton, Todd
Temperature Gradient: Mike, Steve
Gravity and Atmosphere: All Members
Processing: Linton
Cad/Cam: Mike

DIRECT SHEAR TEST SETUP

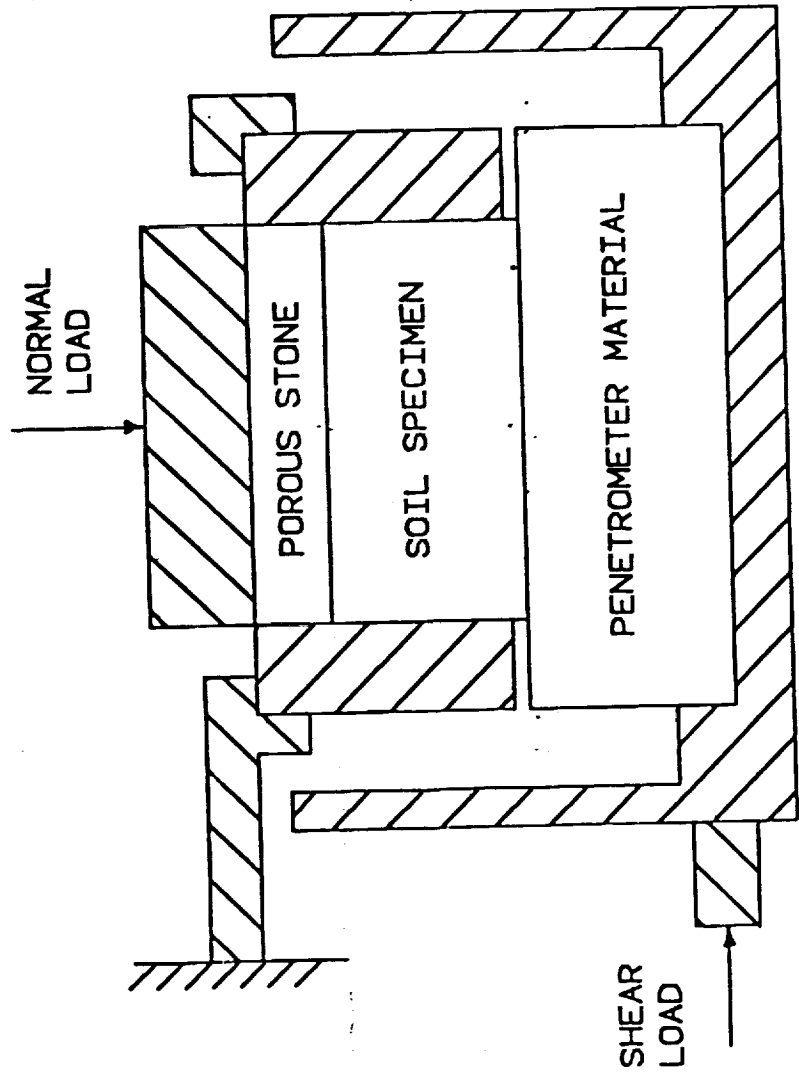

DRAWING #3

July 29, 1987

To: Dr. Williams, ME 4182 Instructor

From: Group 4

Subject: Progress Report, Soil Experiment

During the past week, we have spent time gathering information and data for our presentation which was given by Linton Hutcheson on July 28. Each group member was assigned a certain topic to research for the presentation. The topics and responsible group members are as follows:

TOPIC	GROUP MEMBER
Introduction	Linton
Environmental Conditions	Steve, Mike, Charles, Nadim
Types of Tests Proposed	Steve, Mike, Charles, Nadim, Todd
Equip. Design Utilizing Test	Todd
Conclusion	Linton

In the next week, we are planning to continue the research and start trying to put it all together so that we can be thinking of how we would like to model the test in order to make it work. Each group member will be responsible for the same topic as assigned previously.

PENETRATION TEST SETUP

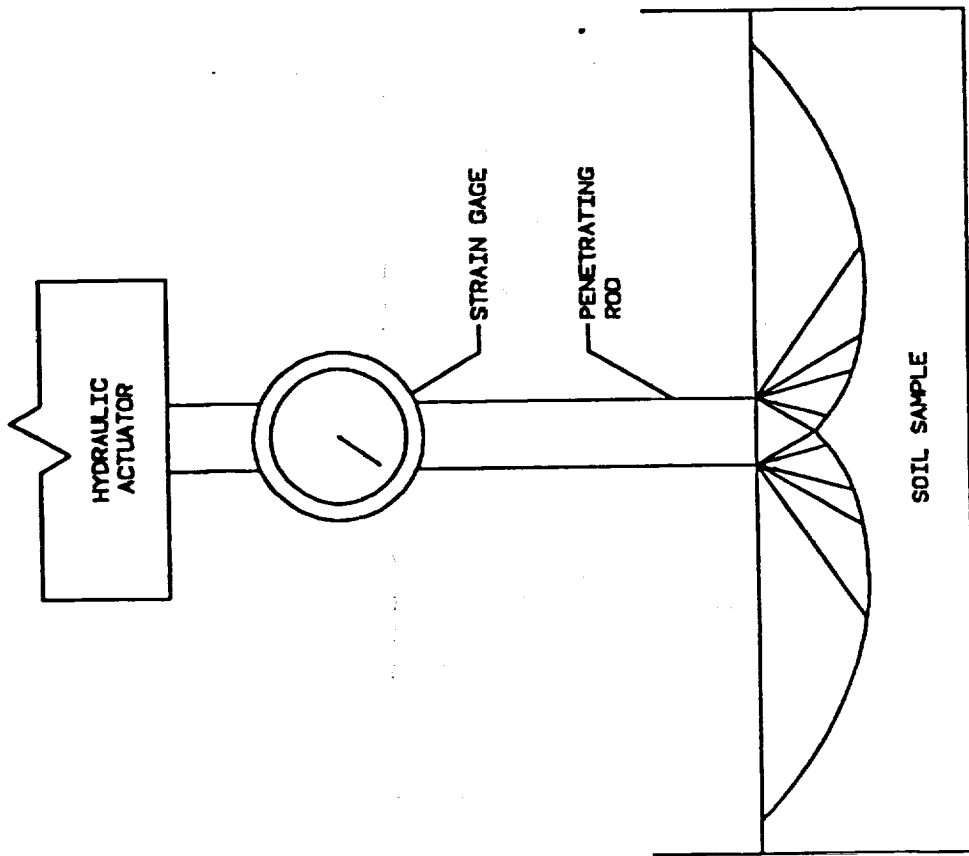

To: GT5812B Gary Von McMurray
From: GT2945B Malcolm Todd Butler
Date: 8/08/04. 16.17.03

Subject: Soil6

To : Dr. Williams, ME 4182 Instructor
From: Group 4
Subject: Progress Report, Soil Experiment

During the past week, our group continued researching the same topics as assigned previously. However, an effort was made to determine exactly what the internal angle of friction is and how it is determined. Our drawing for the week reflects this. We are also at the point of starting to correlate our research material into a rough draft. Starting this week, we plan to call additional meetings in order to start finalizing our report. Topics of the week and responsible group members are as follows:

Topic	Group Member (s)
Environmental conditions	Steve, Nadim, Charles
Type Test Proposed	
-Shear test	Steve, Mike
-Penetration Test	Linton, Todd
-Soil Mechanics	Linton, Nadim
-Word Processing	Todd
-CAD/CAM	Mike

DETERMINATION OF SHEAR STRENGTH & INT. ANGLE OF FRICTION

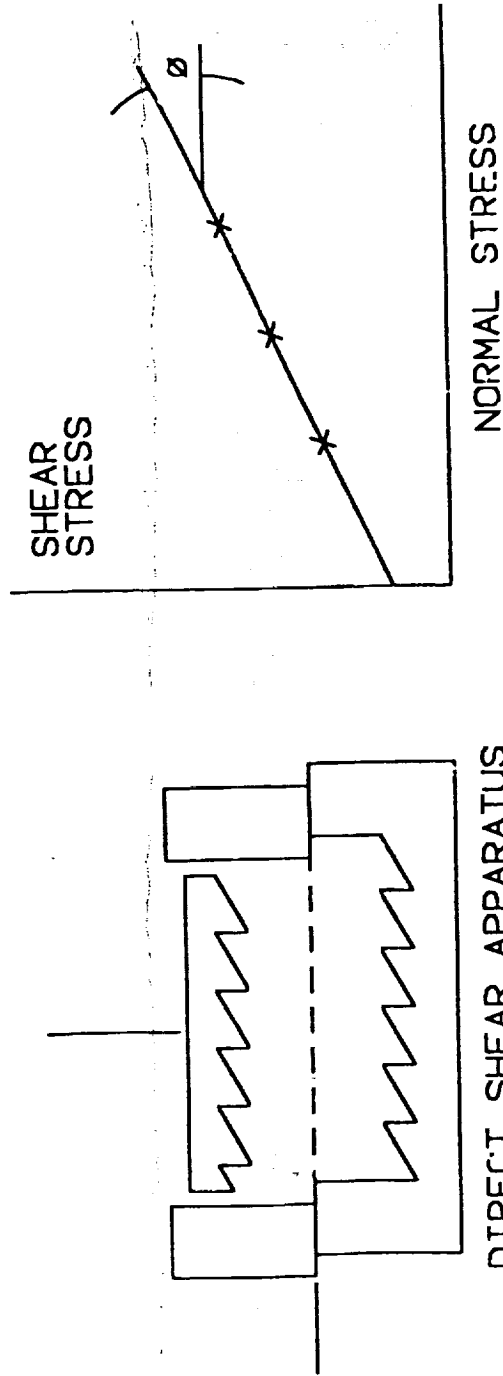

DIRECT SHEAR APPARATUS

DRAWING 4

ORIGINAL PAGE IS
OF POOR QUALITY

To :GT5812B Gary Von McMurrar
From: GT2945b Malcolm Todd Butler
Date: 87/07/07. 17.08.17.

To: Dr.Williams, ME 4182 Instructor
From: Group 4
Subject: Progress report concerning the test apparatus and procedure used to determine the mechanical properties of simulated lunar soil.

Research has been done on the environmental characteristics of the moon. The environmental conditions of the moon impose the greatest design constraints on the testing apparatus. The most important constraints include the following: soil mechanics, radiation, lack of atmosphere, temperature, and reduced gravitational pull.

Other related design projects were studied in order to determine if the digging implement designs in these reports can be used to in our test apparatus. Various geological companies were interviewed to gather information on soil testing procedures that may possibly be incorporated into our project.

We met on tuesday the 7th and discussed the following ideas concerning our project:

- 1) What tests we should choose to work on.
 - a) Shear test
 - b) Penetration test
- 2) Possible meeting times that are best for everyone. We would like to try and split up into three groups of two for the more frequent meetings and then meetings with all members present.

We also composed a rough draft of our problem statement at the meeting.

List of things to do:

- 1) Environmental conditions: Linton, Nadim, Todd
- 2) Soil testing apparatus: Todd, Linton, Nadim
- 3) Lunar excavating bucket (report): Nadim, Steve, Charles
- 4) Nasa soil testing literature: Steve, Mike, Charles
- 5) CAD/CAM: Mike

USE OF SHEAR TEST DATA

DIRECT
SHEAR
TEST

SHEAR
STRENGTH
 c
ANGLE OF
INTERNAL
FRICTION, ϕ

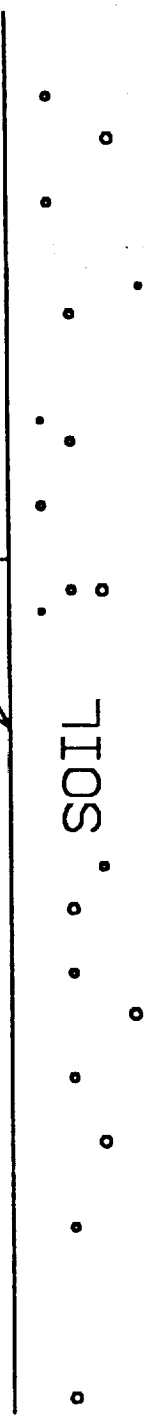
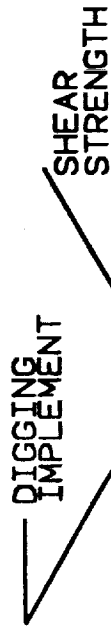

DATE: AUG. 10, 1987

TO: Dr. Williams, ME 4182 Instructor

FROM: Group 4

SUBJECT: Progress Report on Soil Experiment

The actual testing procedure is being developed this week. A meeting was held last thursday to layout an outline for the formal report which is listed as follows:

- I ABSTRACT
- II PROBLEM STATEMENTS
 - A. INTRODUCTION
 - B. PERFORMANCE OBJECTIVE
 - C. CONSTRAINTS
- III DESIGN DETAILS
 - A. SUMMARY
 - B. ENVIRONMENTAL SIMULATION
 - C. SOIL SIMULATION
 - D. SHEAR TEST
 - E. PENETRATION TEST
 - F. TEST PROCEDURE
 - G. METHOD OF EVALUATION / DIGGING IMPLEMENT
- IV PARTS LIST / COST ANALYSIS
- V CONCLUSION
- VI RECOMMENDATIONS
- VII ACKNOWLEDGEMENTS
- VIII BIBLIOGRAPHY
- IX APPENDICIES

INDIVIDUAL INPUT:

MIKE SMITH: This week I continued to do research on the direct shear test. I looked through the vendor catalogs and picked some candidates for our direct shear machine. I spoke with Mr. Jay Woldenberg of Geotest Instrument Corporation. I am currently awaiting the arrival of information from him. Geotest has an instrumented model which outputs 0 to 2 volt signals. I am still searching for a suitable recording device.

LINTON HUTCHESON: This past weekend I worked with Todd on finishing the abstract and problem statement of the outline. I have located various studies on cohesionless soil which utilize the static penetrometer as the testing implement. I have gathered books which contain information on the testing procedures involving the shear and penetration tests. I also obtained some ball park estimates on the costs of penetrometers. On Wednesday I am going to contact Brainard Kilman Manufacturing on some testing apparatus.

CHARLES CLINE: Studied affects of vacuum, radiation, and temperature on materials. Searched for vacuum chamber test facilities.

TODD BUTLER: Contacted Civil Engineering and talked with Dr. Bachus, Dave Brown, and Ed Perkins concerning the static penetrometer and shear test apparatus. Got information on manufacturers of testing apparatus.

NADIM ZAKHIA: How temperature results in an increase in the shear strength and visa versa. Also for the lower normal stress, the stiffness in a vacuum at ambient temperature is approximatly the same as for elevated temperature in atmosphere. (Therefore, stiffness of soil is greater in a vacuum than at atmosphere).

STEVE SCRUGGS: Attempted to call Bromwell and Carrier Inc. to get information

on basalt soil recipe to verify our assumptions about the simulant and to find a quarry that basalt can be obtained from. Attended meeting Thursday. Further solidification on information on simulant and shear test.

DATE: AUGUST 19, 1987

TO: Dr. Williams, ME 4182 Instructor

FROM: Group 4

SUBJECT: Progress Report for Soil Experiment

A meeting was held Sat. the 15th to discuss a deadline for the rough draft. It was decided that the design discussion section of our report should be ready to submit to Charles on Wed. the 19th for typing. The following list is a breakdown of each members responsibilities for the final report:

TODD BUTLER: model construction, locate equipment to be used in final presentation, editing report.

MIKE SMITH: organize and complete drawings to be used in report.

STEVE SCRUGS: aid Charles in preparing report for typing, help prepare visuals for presentation.

NADIM ZAKHIA: outline and organize the appendices for report, typing

CHARLES CLINE: type report

LINTON HUTCHESON: model construction, prepare and give oral presentation, aid in preparing visuals, help organize final report.

INDIVIDUAL INPUT:

TODD BUTLER: Borrowed a static cone penetrometer from Brainard Killman Inc. Gathered materials for model and began construction. Finished rough draft of digging implement section of report.

LINTON HUTCHESON: Arranged to borrow a direct shear test unit from the civil engineering school. Aiding in model construction. Located equipment needed to modify the penetrometer for our experiment.

MIKE SMITH: Locating and confering with the manufacturers of the shear tester to find out if the necessary modifications can be made. Weekly drawing.

STEVE SCRUGS: Obtained information on soil simulant.

CHARLES CLINE: Located an off the self device that would both heat and cool the soil sample for the penetration test. Contacted vender to size the chamber and to specify the location of window.

NADIM ZAKHIA: Studied information of outgassing effects on soils.

SHEAR BOX MODIFICATIONS

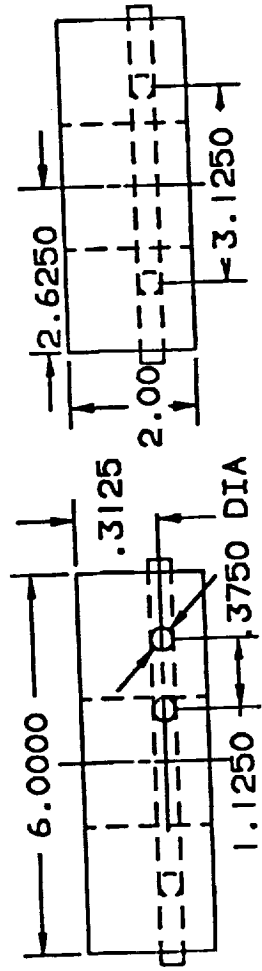
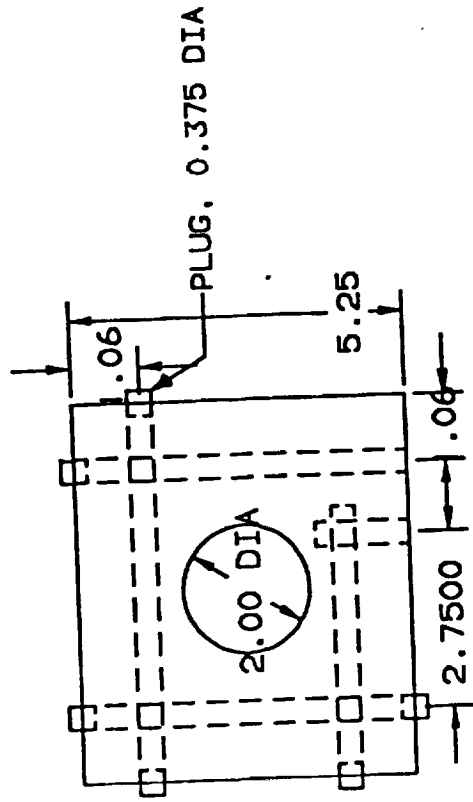

APPENDIX F
MISCELLANEOUS

ORIGINAL PAGE IS
OF POOR QUALITY

SHEAR APPARATUS

INTRODUCTION:

The direct shear test is used to measure the shear strength of soil under drained conditions. This test is well suited to a consolidated drained test because the drainage paths through the test specimen are short, thereby allowing excess pore pressure to be dissipated fairly rapidly. The test can be performed on all soil materials and on undisturbed or remolded samples. A relatively thin soil specimen is placed in a rigid box that is divided horizontally into two frames; the specimen is confined under a vertical (normal) stress and a horizontal force is applied so as to fail the specimen along a horizontal plane at its mid point. Generally a minimum of 3 specimens, each under a different normal stress, are tested.

Several other shear testing systems have evolved in the last few years. Some of the most significant developments are presented at the end of this section. The biaxial apparatus developed by Professors Vardoulakas and Drescher and the simple shear apparatus developed by Professor Budhu are available only from Geotest. The ring shear and debris flow apparatus are available through exclusive agreements with the respective manufacturers.

MOTORIZED DIRECT RESIDUAL SHEAR APPARATUS

Geotest manufactures 3 different direct shear machines. These machines offer a combination of features not available from any other manufacturer:

- Pneumatic application of consolidation load
- Automatic residual shear feature
- Tension and compression load cell for measurement of shear and residual shear stress
- Rapid return feature
- Easy access to shear box
- Digital display of rate of strain
- Consolidation and shear loads up to 2,200 lbf (10 kN) standard
- Speed controlled steplessly to within +/- 1%
- Use of corrosion resistant materials throughout
- Extremely compact in size and attractive in appearance
- Guaranteed against all defects for 2 years
- Made and serviced in U.S.A.

Applying consolidation load pneumatically means that virtually any sample size can be accommodated without changing weight sets, as is necessary on lever loaded units. Loads can be applied instantaneously and without impact. There is no effect from ambient vibration. When placing the shear box in position, the vertical loading frame can be easily removed to provide easy access to the sample.

Performing residual shear tests is automatic. The operator sets a maximum travel and then begins the shear test. When the preset point is reached, the machine automatically reverses

The following 3 models of motorized direct residual apparatus are available:

S2213 MOTORIZED DIRECT SHEAR APPARATUS

This machine offers all features previously described. Normal load is indicated on a 6" diameter test gage accurate to 1/4 of 1 percent. Rate of strain is digitally displayed. Consolidation and shear strain are displayed by respective dial indicators included. Shear and residual shear stress are sensed by a compression-tension load cell and displayed in 1 lbf increments or in international units on a digital readout with a measured 2 volt output to interface with recorder or computer. Any single size shear box, housing, cutting shoe and extruder up to 4X4" is included. No other accessories are necessary. Capacity is 2,200 lbf (10 kN) for normal (consolidation) and shear loads. Speed range (strain rate) is .00001 to .050 inch (.0005 to 1.3 mm) per minute. A rapid return feature permits quick repositioning at end of test. Speed is controlled to better than +/- 1% of set point. Standard voltage characteristics are 115 VAC. For 230 VAC, specify S2213-3. Shipping Weight: 190 lbs (87 kg); 10 cu. ft.

S2215 DIGITAL DIRECT SHEAR APPARATUS

This machine is a completely instrumented version of S2213. Both dial indicators have been replaced with LVDT-dial indicator combinations and digital displays. The 6" test gauge has been replaced by a pressure transducer which displays normal load in 1 lbf increments or kgf on a digital display. All 4 displays have measured 2 volt analog output to interface with a recorder of computer. A fifth display with no output indicates exact rate of strain. Size and weight is same as S2213. Apparatus is furnished complete with one shear box and accessories up to 4X4" (see description of S2213). Standard voltage characteristics are 115 VAC. For 230 VAC, specify S2215-3.

S2216 STRESS STRAIN DIGITAL DIRECT SHEAR APPARATUS

S2216 has same digital displays as S2215 but includes additional instrumentation to permit performance of controlled stress shear tests as well as controlled rate of strain tests. An additional controller permits load to be applied at a constant rate of stress which is set at the operators option. Size and weight is same as S2213 and S2215. Standard voltage characteristics are 115 VAC. For 230 VAC, specify S2216-3.

ACCESSORIES

S2228 Outer Shear Box Housing

The housing is machined from cast naval bronze and is highly resistant to corrosion. It has grooves at bottom to assist in drainage of saturation water. This housing will accommodate any Geotest shear box up to 4X4" (10X10 cm).

S2230 Shear Box 2X2" (5.04 X 5.04 cm)

**S2208 LEVER MOTORIZED DIRECT/RESIDUAL
SHEAR APPARATUS**

This apparatus, not manufactured by Geotest, offers a lower cost method to perform direct and residual shear tests than S2213, 15 and 16 previously described. Its features and quality compare very favorably to other foreign manufactured shear apparatus now being sold in the U.S.A.

Any size standard shear box up to 4x4" (100x100 mm) can be accommodated. The vertical load is applied to the specimen by a 10:1 lever loading system. The carriage is mounted on low friction ball tracks. Shearing load is applied by an infinitely variable electronic drive unit with actual rate of strain digitally displayed. Speeds can be varied from .001 to 1.2 mm per minute. The carriage constructed of non-ferrous material contains the 2 halves of the brass shear box.

Two dial indicators measure respectively consolidation and shear strain. A proving ring, 3 kN capacity, measures shear stress. Four limit switches prevent overrun in any direction. Residual shear tests are accomplished by reversing travel. Maximum horizontal travel is 40 mm. Apparatus includes all necessary accessories except shear box which must be ordered separately. Standard weight set of 50 kg total is included. Dimensions are 44x23x46" (1100x580x1160 mm). Standard voltage is 115 VAC. For 230 VAC, specify S2208-3. Shipping Weight: 570 lbs (259 kg); 42 cu. ft.

Accessories for S2208

S2208-A Shear Box 2.5" diameter.

The shear box includes 2 porous stones and adapter to fit into shear machine carriage. Sample is 1" high.

S2208-B Shear Box 60 mm diameter.

S2208-C Shear Box 60x60 mm.

S2208-G Shear Box 100x100 mm.

Sample cutters and tampers for above sizes are also available.

S2340 PORTABLE DIRECT SHEAR APPARATUS (LST)

This apparatus makes it possible to study mechanism to initiate debris flows as undrained shear of loose sediment in situ. LST refers to Land Slide Testing. Dr. Kyoji Sassa is the inventor of the LST.

The complete apparatus is carried in a light, aluminum alloy, attache type carrying case. Means are provided to take an undisturbed sample measuring 20x20x10 cm, saturating the sample and immediately performing the test. Normal load is applied by moving a weight along a graduated lever arm. Shearing force is applied with a hand screw jack. The shear box has an upper and lower portion which are free to move during test. A 200 kgf proving ring and ruler measure shear stress and strain.

The complete apparatus supplied includes matched set of proving rings, 50 kg of weights, consolidation dial indicator, sample preparation rings with hollow punch and porous stones. Overall dimensions are 70x70x125 cm. Voltage requirements are 115/60/1. For 230/50/1, specify S2350-3. Shipping Weight: 500 lbs (227 kg); 30 cu. ft.

S2360 RING SHEAR TYPE DEBRIS FLOW APPARATUS

This apparatus also invented by Dr. Kyoji Sassa is now being used by the U.S. Geological Survey to study mechanism in liquified land slides including debris flow. In use a sample is placed in a ring type shear box referred to as a sample box and saturated with water. The sample box consists of an upper half ring and a lower half ring and the sample shears along the junction of the two rings when a turning movement is applied to the lower half ring while the upper half ring remains stationary. A vertical load is applied to the sample while the torque and/or turning angle are being measured as the sample is sheared.

O.D. of sample box is 48 cm; I.D. is 30 cm and over all height of upper and lower halves is 9 cm. Shearing force is provided by a servo motor. The high speed range using the motor drive is useful in performing liquefaction tests while the low speed range is recommended for drained shear tests. Using the servo drive provides a controlled rate of strain test while using the servo drive with feedback allows testing to be done under controlled rate of stress conditions.

Vertical (normal loading) is done pneumatically with air provided from an air compressor. Load is applied evenly over entire top surface of sample.

Load cells measure vertical and shearing forces; turning angle is measured by a potentiometer; volume change by a dial indicator and differential transformer; vertical displacement is measured with a dial indicator. The following 4 properties are digitally displayed on electronic readouts with outputs that will interface to a data recording system or computer if desired: ie vertical load, shearing torque, turning angle and volume change.

More detailed information on this apparatus as well as copies of papers presented by Dr. Sassa are available upon request from Geotest.

SIMPLE SHEAR APPARATUS

INTRODUCTION

A simple shear test - a plane strain test in which the principal axes of stress and strain rotate-closely approximates the conditions likely to occur in a soil mass in many practical situations. There are several very interesting simple shear devices being sold throughout the world. Almost all are now based on the Norwegian Geotechnical Institute (NGI) design which

5. The device can be controlled manually or by a computer.

6. Digital readouts are standard items for normal stresses, shear stresses, pore water pressures, vertical and shear displacements and volume change. For cyclic tests, a six channel high speed strip chart recorder is recommended and can be provided.

S2401 BUDHU SIMPLE SHEAR APPARATUS

Vertical load is applied pneumatically in a system similar to our direct shear apparatus (S2213, 15, 16). When placing the shear box in position, the vertical loading frame can be easily removed to provide easy access to the sample and load cell. Vertical and shear displacements are measured by specially designed LVDT's and digitally displayed. Normal stress, shear stress and pore pressures are measured by a special load cell in the center of the top platen and digitally displayed with a measured output for connection to a computer or recorder. Additionally the apparatus has an IEEE-488 interface. Maximum vertical stress is 1500 kPa. However, a higher capacity can be provided

If cyclic and closed loop control is not required, a lower cost drive system similar to that provided in our direct shear apparatus can be offered. The system provided in S2401 is a fully automated servo-controlled apparatus with capability of applying static or cyclic (up to 2 Hertz) simple shear loading to the sample under drained or undrained conditions to a maximum applied shear stress of 1500 kPa. The system is capable of applying load under both strain-controlled and stress-controlled conditions. Loading can be controlled manually or by a computer.

To achieve sample saturation, back pressures to 1000 kPa can be applied. Pore pressure can be measured throughout all test phases. All components in contact with sample pore fluid are of corrosion resistant materials. Soils ranging from loose sands, dilatant silts and soft to very stiff clays can be tested.

A separate control panel, similar in appearance to S5424, monitors and controls back pressure, digitally displays pore pressure and volume change.

Any size sample square (or circular if desired) can be provided up to 70x70 mm (or 2.8" diameter). Standard sizes now available are 45x45 and 65x65 mm. The sample is enclosed within a rubber membrane and surrounded by square articulated teflon coated rings. Apparatus includes one size shear box and sample preparation accessories which permit both tube and stiffer trimmed samples to be conveniently installed.

The basic simple shear apparatus occupies table space of 40x16". The control panel measures 23x12x40 1/2". Additional space should be provided for a 6 channel recorder, data logger, printer etc. if needed. Computer software is being developed and will be available in a short period of time.

The soil specimen is a right rectangular prism with dimensions 140x40x80 mm. Two opposite faces are supported by walls enclosed between two rigid walls inducing plane-strain conditions. The specimen is surrounded by a thin rubber membrane. The axial load is kinematically applied by an enlarged upper plate guided to prevent any tilt or eccentricity. The bottom plate is enlarged and horizontally guided by a linear bearing parallel to the plane of deformation. All the surfaces in contact with the specimen are glass lined and lubricated to minimize friction. The assemblage is placed into a conventional triaxial cell in a loading frame, in order to apply the confining pressure and to drive the top plate vertically.

Internally located load-cells allow for accurate measurement of the axial force, its eccentricity and the friction along the side walls. LVDT displacement transducers monitor the axial and the lateral displacements of the specimen, and the horizontal movement of the base plate. Additional modifications to the apparatus will permit measurement of pore pressure and intermediate principal stress.

S2600 is the basic biaxial apparatus less the various LVDT's, load cells, and transducers needed to completely instrument this apparatus. The cell and instrumentation are listed separately. The load frame recommended is S5720, S5721, or S5722.

OTHER SHEAR TEST APPARATUS

E-280 POCKET PENETROMETER

The pocket soil penetrometer is a frequently used instrument for classifying soils. It is a spring operated device used to measure compressive strength of soil by pushing a ground and polished 1/4" diameter loading piston into soil to a depth of .25". The end area is .05 square inch. A special adapter foot is available as an option for use in very sensitive soils.

Compressive load in tons per square foot or Kg per square cm is indicated by reading scale on piston barrel. Maximum reading reached is shown by friction ring. A plastic carrying case with belt loop is included. Length 6 1/4".
Shipping Weight: 1 lb (.45 kg); .1 cu. ft.

E-281 Penetrometer Adapter Foot 1" diameter.

E-285 TORSIONAL VANE SHEAR DEVICE

This vane tester is used to rapidly determine shear strength of cohesive soils in the field or laboratory. In use the vaned foot is inserted into a flat soil surface and the upper portion is turned developing increasing torsional force until the soil shears. The maximum reading retained by the pointer is recorded and then manually returned to zero. The standard vane device has a medium vaned foot and a scale of 0 to 1 TSF or Kg/sq. cm. in .05 units. A wrench is included to replace standard vane with sensitive (E-288S) or high capacity (E-285HC) vaned foot. The



Standard Method for DEEP, QUASI-STATIC, CONE AND FRICTION-CONE PENETRATION TESTS OF SOIL¹

This standard is issued under the fixed designation D 3441; the number immediately following the designation indicates the year of original adoption or, in the case of revision, the year of last revision. A number in parentheses indicates the year of last revision. A superscript epsilon (ϵ) indicates an editorial change since the last revision or reapproval.

1. Scope

1.1 This method covers the determination of end bearing and side friction, the components of penetration resistance which are developed during the steady slow penetration of a pointed rod into soil. This method supplies data on the engineering properties of soil intended to help with the design and construction of earthworks and foundations for structures. This method is sometimes referred to as the "Dutch Cone Test."

1.2 This method includes the use of both cone and friction-cone penetrometers, of both the mechanical and electric types.

NOTE 1—This method does not include hydraulic penetrometers. Such penetrometers use a hydraulic system to extend the penetrometer tip, or to transmit the penetration resistance(s) from the tip to the recording unit, or both. However, many of the requirements herein could also apply to hydraulic penetrometers.

1.3 Mechanical penetrometers of the type described in this method operate incrementally, using a telescoping penetrometer tip, resulting in no movement of the push rods during the measurement of the resistance components. Design constraints for mechanical penetrometers preclude a complete separation of the end-bearing and side-friction components. Electric penetrometers are advanced continuously and permit separate measurement of both components. Differences in shape and method of advance between cone penetrometer tips may result in significant differences in one or both resistance components.

2. Definitions

2.1 *cone penetrometer*—an instrument in

the form of a cylindrical rod with a conical point designed for penetrating soil and rock and for measuring the end-bearing component of penetration resistance.

2.2 *friction-cone penetrometer*—a cone penetrometer with the additional capability of measuring the local side friction component of penetration resistance.

2.3 *mechanical penetrometer*—a penetrometer that uses a set of inner rods to operate a telescoping penetrometer tip and to transmit the component(s) of penetration resistance to the surface for measurement.

2.4 *electric penetrometer*—a penetrometer that uses electric-force transducers built into a nontelelescoping penetrometer tip to measure, within the tip, the component(s) of penetration resistance.

2.5 *penetrometer tip*—the end section of the penetrometer, which comprises the active elements that sense the soil resistance, the cone, and in the case of the friction-cone penetrometer, the friction sleeve.

2.6 *cone*—the cone-shaped point of a penetrometer tip, upon which the end-bearing resistance develops.

2.7 *friction sleeve*—a section of the penetrometer tip upon which the local side-friction resistance develops.

2.8 *push rods*—the thick-walled tubes or other suitable rods, used for advancing the penetrometer tip to the required test depth.

¹ This method is under the jurisdiction of ASTM Committee D-18 on Soil and Rock and is the direct responsibility of Subcommittee D18.02 on Sampling and Related Field Testing for Soil Investigations.

Current edition approved June 29, 1979. Published August 1979. Originally published as D 3441 - 75 T. Last previous edition D 3441 - 75 T.

2.9 *inner rods*—rods that slide inside the push rods to extend the tip of a mechanical penetrometer.

2.10 *cone resistance or end-bearing resistance*—the resistance to penetration developed by the cone, equal to the vertical force applied to the cone divided by its horizontally projected area.

2.11 *friction resistance, f_s* —the resistance to penetration developed by the friction sleeve, equal to the vertical force applied to the cone divided by its surface area. This resistance consists of the sum of friction and end-bearing.

2.12 *friction ratio, R_f* —the ratio of friction resistance to cone resistance, f_s/q_c , expressed in percent.

2.13 *cone sounding*—the entire series of penetration tests performed at one location when using a cone penetrometer.

2.14 *friction-cone sounding*—the entire series of penetration tests performed at one location when using a friction-cone penetrometer.

2.15 *apparatus*—

2.15.1 *General*—

2.15.1.1 *Cone*—The cone shall have a 60-degree point angle and a base diameter of 1.55 ± 0.016 in. (35.7 \pm 0.4 mm), resulting in a projected area of 1.55 in.² (10 cm²).

2.15.1.2 *Tip*—In soft soils, the total soil-resistance on the cone may be insufficient to support the standard weight of the cone and inner rods of a mechanical penetrometer. In this case, tips with a larger projected area may be used if their geometry remains similar to that for the 1.55 in.² (10 cm²) tip.

2.15.1.3 *Friction Sleeve*—having the same outside diameter +0.024 to -0.000 in. (+0.5 to -0.1 mm) as the base diameter of the cone (2.15.1.1). No other part of the penetrometer shall project outside the sleeve diameter.

2.15.1.4 *Surface Area*—The surface area of the sleeve shall be 15.5 or 32 in.² (100 or 150 cm²) \pm 2%.

2.15.1.5 *Steel*—The cone and friction sleeve shall be made from steel of a type and hardness suitable to resist wear due to abrasion by soil. The friction sleeve shall have and maintain with use a roughness of 20 μ in. (0.5 μ m) \pm 50%.

2.15.1.6 *Push Rods*—Made of suitable steel. These rods must have a section adequate

sustain, with to advance have an outside diameter of of at least 1.0 ft. The case of least 1.0 ft. friction sleeve same, consist screw or at other and f with a con

3.1.5 *Inter*—The metal alloy rods. They must outside diameter. They must rods (\pm 0.0 section advance without be between mm). See

3.1.6 *M*—The thrust-correct value

3.2 *Mech*—A mechanical downward to the push

NOTE 3—The tip resists inner rods the thrust relative to not extend fully to the jump abrasion; contact with t

3.2.2 *M*—shall include the sliding

3.2.3 *C*—the design penetrometer is at possible

3.2.4 *M*—The

Apollo 12: Penetrometer (Surveyor III)		N/A	Mitchell (1970) Jaffe (1971)
Apollo 12: Vacuum Direct Shear	0-0.7	28-35	Carrier et al. (1972b, 1973c)
Apollo 12: Direct Shear (Surveyor III)	0.1-3.1	13-56	Jaffe (1973)
Luna 16 & 20: Direct Shear and Coulomb Device	3.9-5.9	20-25	Leonovich et al. (1974, 1975); Gromov et al. (1972)

- * Assumed
 † Mean of 69 values
 § Mean of 25 values
 ‡ Estimated

SOURCE: DAVID CARRIER - ROUGH MANUSCRIPT OF A TO BE PUBLISHED BOOK
 1987

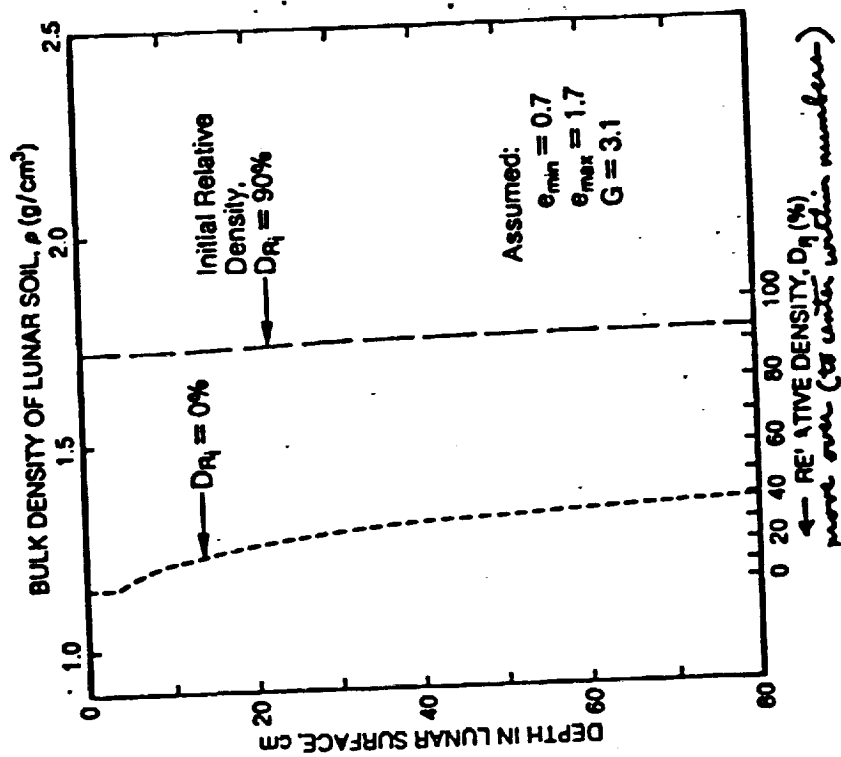

SOURCE: DAVID CARRIER III ROUGH MANUSCRIPT OF A TO BE PUBLISHED BOOK 1987

Fig. 7.2.7-3
 Densification of Lunar Soil Due to Self-Weight Compression in Lunar Gravity

C, CONE AND FRICTION-CONE TESTS OF SOIL¹

3441; the number immediately following the designation indicates the year of last revision. A number in parentheses indicates the year of last approval since the last revision or approval.

the form of a cylindrical rod with a conical point designed for penetrating soil and soft rock and for measuring the end-bearing component of penetration resistance.

2.2 *friction-cone penetrometer*—a cone penetrometer with the additional capability of measuring the local side friction component of penetration resistance.

2.3 *mechanical penetrometer*—a penetrometer that uses a set of inner rods to operate a telescoping penetrometer tip and to transmit the component(s) of penetration resistance to the surface for measurement.

2.4 *electric penetrometer*—a penetrometer that uses electric-force transducers built into a nontelelescoping penetrometer tip for measuring, within the tip, the component(s) of penetration resistance.

2.5 *penetrometer tip*—the end section of the penetrometer, which comprises the active elements that sense the soil resistance, the cone, and in the case of the friction-cone penetrometer, the friction sleeve.

2.6 *cone*—the cone-shaped point of the penetrometer tip, upon which the end-bearing resistance develops.

2.7 *friction sleeve*—a section of the penetrometer tip upon which the local side-friction resistance develops.

2.8 *push rods*—the thick-walled tubes or other suitable rods, used for advancing the penetrometer tip to the required test depth.

¹This method is under the jurisdiction of ASTM Committee D-18 on Soil and Rock and is the direct responsibility of Subcommittee D18.02 on Sampling and Routine Testing for Soil Investigations.

Current edition approved June 29, 1979. Published April 1979. Originally published as D 3441 - 75 T. Last previous edition D 3441 - 75 T.

instrument in

2.9 *inner rods*—rods that slide inside the push rods to extend the tip of a mechanical penetrometer.

2.10 *cone resistance or end-bearing resistance, q_c* —the resistance to penetration developed by the cone, equal to the vertical force applied to the cone divided by its horizontally projected area.

2.11 *friction resistance, f_s* —the resistance to penetration developed by the friction sleeve, equal to the vertical force applied to the sleeve divided by its surface area. This resistance consists of the sum of friction and adhesion.

2.12 *friction ratio, R_f* —the ratio of friction resistance to cone resistance, f_s/q_c , expressed in percent.

2.13 *cone sounding*—the entire series of penetration tests performed at one location when using a cone penetrometer.

2.14 *friction-cone sounding*—the entire series of penetration tests performed at one location when using a friction-cone penetrometer.

3 *Apparatus*

3.1 *General:*

3.1.1 *Cone*—The cone shall have a 60-deg (1.047 rad) point angle and a base diameter of 1.00 ± 0.016 in. (25.4 ± 0.4 mm), resulting in a projected area of 1.55 in.² (10 cm²).

NOTE 2—In soft soils, the total soil-resistance force on the cone may be insufficient to support the combined weight of the cone and inner rods of the mechanical penetrometer. In this case, tips with a larger projected area may be used if their geometry remains similar to that for the 1.55 in.² (10 cm²) tip.

3.1.2 *Friction Sleeve*, having the same outside diameter $+0.024$ to -0.000 in. ($+0.5$ to -0.0 mm) as the base diameter of the cone (see 3.1.1). No other part of the penetrometer shall project outside the sleeve diameter.

The surface area of the sleeve shall be 15.5 or 21.2 in.² (100 or 150 cm²) $\pm 2\%$.

3.1.3 *Steel*—The cone and friction sleeve shall be made from steel of a type and hardness suitable to resist wear due to abrasion by soil. The friction sleeve shall have and maintain with use a roughness of 20 μ in. (0.5 μ m) or less.

3.1.4 *Push Rods*—Made of suitable steel. These rods must have a section adequate

to sustain, without buckling, the thrust required to advance the penetrometer tip. They must have an outside diameter not greater than the diameter of the base of the cone for a length of at least 1.3 ft (0.4 m) above the base, or, in the case of the friction-cone penetrometer, at least 1.0 ft (0.3 m) above the top of the friction sleeve. Each push rod must have the same, constant inside diameter. They must screw or attach together to bear against each other and form a rigid-jointed string of rods with a continuous, straight axis.

3.1.5 *Inner Rods*—Mechanical penetrometers require a separate set of steel, or other metal alloy, inner rods within the steel push rods. The inner rods must have a constant outside diameter with a roughness, excluding waviness, less than 10 μ m. (0.25 μ m) AA. They must have the same length as the push rods (± 0.004 in. or ± 0.1 mm) and a cross section adequate to transmit the cone resistance without buckling or other damage. Clearance between inner rods and push rods shall be between 0.020 and 0.040 in. (0.5 and 1.0 mm). See 5.8.1.

3.1.6 *Measurement Accuracy*—Maintain the thrust-measuring instrumentation to obtain thrust measurements within $\pm 5\%$ of the correct values.

3.2 *Mechanical Penetrometers:*

3.2.1 The sliding mechanism necessary in a mechanical penetrometer tip must allow a downward movement of the cone in relation to the push rods of at least 1.2 in. (30.5 mm).

NOTE 3—At certain combinations of depth and tip resistance(s), the elastic compression of the inner rods may exceed the downward stroke that the thrust machine can apply to the inner rods relative to the push rods. In this case, the tip will not extend and the thrust readings will rise elastically to the end of the machine stroke and then jump abruptly when the thrust machine makes contact with the push rods.

3.2.2 Mechanical penetrometer tip design shall include protection against soil entering the sliding mechanism and affecting the resistance component(s) (see 3.2.3 and Note 4).

3.2.3 *Cone Penetrometer*—Figure 1 shows the design and action of one mechanical cone penetrometer tip. A mantle of reduced diameter is attached above the cone to minimize possible soil contamination of the sliding mechanism.

Fig. 4—An unknown amount of side friction develops along this mantle and be included in the resistance.

4 Friction-Cone Penetrometer—Fig. 5 shows the design and action of one opening mechanical friction-cone penetrometer tip. The lower part of the tip, in contact with the mantle to which the cone attaches, moves first until the flange engages the inner sleeve and then both advance.

Fig. 5—The shoulder at the lower end of the sleeve encounters end-bearing resistance. As much as two thirds of the sleeve resistance may consist of bearing on this shoulder. It has little effect in soft to medium clays.

5 Measuring Equipment—Measure penetration resistance(s) at the surface by any suitable device such as a hydraulic or electric cell or proving ring.

Electric Penetrometers:

4.1 Cone Penetrometer—Figure 3 shows the design for an electric-cone penetrometer. The cone resistance is measured by means of a force transducer attached to the tip. An electric cable or other suitable system transmits the transducer signals to a data recording system. Electric-cone penetrometers shall permit continuous advance and recording over each push rod-length interval.

4.2 Friction-Cone Penetrometer—The diameter of the friction sleeve shall not be less than 0.4 in. (10 mm) above the base of the cone. The same requirements as 3.3.1 apply. Figure 4 shows one design for an electric-friction-cone penetrometer tip.

4 Thrust Machine—This machine shall provide a continuous stroke, preferably over a distance greater than one push rod length. The machine must advance the penetrometer tip at a constant rate while the magnitude of the thrust required fluctuates (see 4.1.2).

NOTE 6—Deep penetration soundings usually require a thrust capability of at least 5 tons (45 kN). Modern machines use hydraulic pistons with 20-ton (90 to 180-kN) thrust capability.

5 Reaction Equipment—The proper performance of the static-thrust machine requires a stable, static reaction.

NOTE 7—The type of reaction provided may affect the penetrometer resistance(s) measured, particularly in the surface or near-surface layers.

Procedure

4.1 General:

4.1.1 Set up the thrust machine for a downward direction as near vertical as practical.

4.1.2 Rate of Penetration—Maintain a constant rate of depth penetration of 2 to 4 ft/min (610 to 1220 mm/s) ± 25% when obtaining resistance data. Other rates of penetration may be used between tests.

NOTE 8—The rate of 2 ft/min (610 mm/s) governs the time the operator needs to read properly the resistance values when using the mechanical friction-cone penetrometer. The rate of 4 ft/min (1220 mm/s) is suitable for the single resistance penetrometer and provides for the efficient operation of electric penetrometers.

NOTE 9—The engineer may wish to test the reduced rates of penetration to study possible effects of pressure and other effects on the resistance component(s) obtained using the standard rate.

4.2 Mechanical Penetrometers:

4.2.1 Cone Penetrometer—(1) Advance the penetrometer tip to the required test depth by applying sufficient thrust on the push rods, and (2) Apply sufficient thrust on the inner rods to extend the penetrometer tip (see Fig. 5). Obtain the cone resistance at a specific point (see 4.2.3) during the downward movement of the inner rods relative to the stationary push rods. Repeat step (1). Apply sufficient thrust on the push rods to collapse the extended tip and advance it to a new test depth. By continually repeating this two-step cycle, obtain cone resistance data at increments of depth. This increment shall not normally exceed 8 in. (203 mm).

4.2.2 Friction-Cone Penetrometer—Use this penetrometer as described in 4.2.1 to obtain two resistances during the step of extension of the tip (see Figs. 2 and 5). Then obtain the cone resistance during the initial phase of the extension. When the lower part of the tip engages and pulls down the friction sleeve, obtain a second measurement of the total resistance of the cone plus the sleeve resistance. Subtraction gives the sleeve resistance.

NOTE 10—Because of soil layering, the cone resistance may change during the additional downward movement of the tip required to obtain the friction measurement (see Note 14).

NOTE 11—The soil friction along the sleeve plus an additional overburden load on the soil above the cone and may increase cone resistance above that measured during the initial phase of the tip extension by an unknown, but probably small amount. Ignore this effect.

4.2.3 Recording Data—To obtain

the cone-resistance test data, or cone and friction-resistance test data when using a friction-cone tip, record only those thrust readings that occur at a well-defined point during the downward movement of the top of the push rods in relation to the top of the push rods. Because of the elastic compression of the rods (see Note 3), this point ordinarily should be at not less than 1.0 in. (25 mm) of relative movement of the inner rods. When using the friction-cone penetrometer, this point shall be just before the cone engages the friction sleeve.

NOTE 12—Figure 5 shows one example of how the thrust in the hydraulic load cell can vary during the extension of the friction-cone tip. Note the drop in page pressure when the cone engages the sleeve.

4.2.3.1 Obtain the cone plus friction-resistance reading as soon as possible after the tip has moved to the test depth as to minimize the error described in Fig. 5. Unless using continuous recording as in Fig. 5, the operator should not record a cone plus friction resistance if he suspects that cone resistance is changing abruptly or cyclically.

4.3 Electric Penetrometers:

4.3.1 If using continuous electric cable, withdraw it through the push rods.

4.3.2 Record the initial reading(s) with the penetrometer tip hanging freely in air or in water, out of direct sunlight, and after an initial, short penetration, test hole so that the temperature is at soil temperature.

4.3.3 Record the cone resistance, or cone resistance and friction resistance, continuously with depth or note them at intervals of depth not exceeding 8 in. (203 mm).

4.3.4 At the end of a sounding, obtain a final set of readings as in 4.3.2 and check them against the initial set. Discard the soundings and repair or replace the tip if this check is not satisfactory for the accuracy desired for the resistance component(s).

5 Special Techniques and Precautions

5.1 Reduction of Friction Along Push Rods—The purpose of this friction reduction is to increase the penetrometer depth capability, and not to reduce any differences between resistance components determined by mechanical and electric tips as noted in 1.3. To accomplish the friction reduction, intro-

duce a special or special producer, into between the push rods with tip.

5.2 Prevent Face—Use the thrust to prevent significant between the

NOTE 13—Working through the stem of casing buckling of

5.3 Drift Exceeding—probably d ment. Occ even at less push rods making su into soil d lateral thro obstruction

tions, thin ers may c Note any obstruction iment im re-ly-ig. ch te- of

NOTE 14—Incorporate provide a

5.4 We sive soils the pene thereof, or surfac the req scratch-

5.5 Dr Sleeve—applies t soil in ' set tained a these re depth, f ratios of take pre between

height of the friction sleeve.

5.6 Interruptions—The engineer may have to interrupt the normal advance of a static penetration test for purposes such as removing the penetrometer and drilling through layers or obstructions too strong to penetrate statically. If the penetrometer is designed to be driven dynamically without damage to its subsequent static performance (those illustrated herein in Figs. 1 to 4 are not so designed), the engineer may drive past such layers or obstructions. Delays of over 10 min due to personnel or equipment problems shall be considered an interruption. Continuing the static penetration test after an interruption is permitted provided this additional testing remains in conformance with this standard. Obtain further resistance component data only after the tip passes through the engineer's estimate of the disturbed zone resulting from the nature and depth of the interruption. As an alternative, readings may be continued without first making the additional tip penetration and the disturbed zone evaluated from these data. Then disregard data within the disturbed zone.

5.7 Below or Adjacent to Borings—A cone or friction-cone sounding shall not be performed any closer than 25 boring diameters from an existing, unbackfilled, uncased boring hole. When performed at the bottom of a boring, the engineer should estimate the depth below the boring of the disturbed zone and disregard penetration test data in this zone. This depth shall be at least three boring diameters.

5.8 Mechanical Penetrometers:

5.8.1 Inner Rod Friction—Soil particles and corrosion can increase the friction between inner rods and push rods, possibly resulting in significant errors in the measurement of the resistance component(s). Clean and lubricate the inner rods.

5.8.2 Weight of Inner Rods—For improved accuracy at low values of cone resistance, correct the thrust data to include the accumulated weight of the inner rods from the tip to the topmost rod.

5.8.3 Jamming—Soil particles between sliding surfaces or bending of the tip may jam the mechanism during the many extensions and collapses of the telescoping mechanical tip. Stop the sounding as soon as uncorrect-

ble jamming occurs.

5.9 Electric Penetrometers:

5.9.1 Water Seal—Provide waterproofing for the electric transmission. Make periodic checks to assure that no water has passed the seals.

6. Report

6.1 Graph of Cone Resistance, q_c —The report of a cone or friction-cone sounding shall include a graph of the variation of cone resistance (in units of tons/ft² or 100 kPa) with depth (in feet or metres). Successive cone resistance test values from the mechanical cone and friction-cone penetrometers, normally determined at equal increments of depth and plotted at the depth corresponding to the depth of the measurement, may be connected with straight lines as an approximation to a continuous graph.

6.2 Friction-Cone Penetrometer:

6.2.1 Graph of Friction Resistance, f_s —In addition to the graph of cone resistance, the report may include an adjacent or superposed graph of friction resistance or friction ratio, or both, with depth. Use the same depth scale as in 6.1 (see 5.5).

6.2.2 Graph of Friction Ratio, R_f —If the report includes soil descriptions obtained from the friction-cone penetrometer, include a graph of the variation of friction ratio with depth. Place this graph adjacent to the graph for cone resistance, using the same depth scale (see 5.5).

6.3 General—The operator shall include his name, the name and location of the sounding, sounding number, sounding coordinates, and soil and water surface conditions (if available). The report shall include a note as to the type of penetrometer used, the type of thrust machine, the method used to provide the reaction force, if a friction reducer was used, the method of advancement, the method of recording, condition of the rods and tip after withdrawal, and any special difficulties or observations concerning the performance of the equipment.

6.4 Deviations from Standard—The report shall state that the test procedure was in accordance with this Method D 3441 and describe completely any deviations from the method.

6. Precision and Accuracy

7.1 Because of the many variables involved and the lack of a superior standard, operators have no direct data to determine the accuracy of this method. Judging from its observed reproducibility in approximately uniform soil deposits, plus the q_c and f_s measurement effects of special equipment and op-

erator estim...
7.1...
7.1...
5% in...
NOT...
data fr...

This standard is subject to revision at any time by the responsible technical committee. Your comments are invited and should be addressed to ASTM Headquarters. Your comments will appear in technical committee, which you may attend. If you feel that your comments will not be known to the ASTM Committee on Standards, 1916 Race

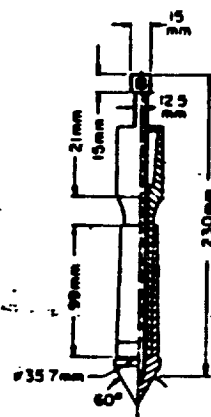

COLLAPSED

FIG. 1 Example of a Mechanical Cone Penetrometer

ble jamming occurs.

5.9 Electric Penetrometers:

5.9.1 Water Seal—Provide waterproofing for the electric transmission. Make periodic checks to assure that no water has passed the seals.

6. Report

6.1 Graph of Cone Resistance, q_c —The report of a cone or friction-cone sounding shall include a graph of the variation of cone resistance (in units of tons/ft² or 100 kPa) with depth (in feet or metres). Successive cone resistance test values from the mechanical cone and friction-cone penetrometers, normally determined at equal increments of depth and plotted at the depth corresponding to the depth of the measurement, may be connected with straight lines as an approximation to a continuous graph.

6.2 Friction-Cone Penetrometer:

6.2.1 Graph of Friction Resistance, f_s —In addition to the graph of cone resistance, the report may include an adjacent or superimposed graph of friction resistance or friction ratio, or both, with depth. Use the same depth scale as in 6.1 (see 5.5).

6.2.2 Graph of Friction Ratio, R_f —If the report includes soil descriptions obtained from the friction-cone penetrometer, include a graph of the variation of friction ratio with depth. Place this graph adjacent to the graph for cone resistance, using the same depth scale (see 5.5).

6.3 General—The operator shall state his name, the name and location of the project, date of sounding, sounding number, bearing coordinates, and soil and water surface elevations (if available). The report shall also include a note as to the type of penetrometer used, the type of thrust machine, the reaction used to provide the reaction force, if a reaction reducer was used, the method of recording advancement, the method of recording the condition of the rods and tip after withdrawal, and any special difficulties or observations concerning the performance of the equipment.

6.4 Deviations from Standard—The report shall state that the test procedure was in accordance with this Method D and shall describe completely any deviations from the method.

8. Precision and Accuracy

8.1 Because of the many variables involved and the lack of a superior standard, engineers have no direct data to determine the accuracy of this method. Judging from its observed reproducibility in approximately uniform soil deposits, plus the q_c and f_s measurement effects of special equipment and op-

erator care, persons familiar with this method estimate its precision as follows:

7.1.1 Mechanical Tips—Standard deviation of 10 % in q_c and 20 % in f_s .

7.1.2 Electric Tips—Standard deviation of 5 % in q_c and 10 % in f_s .

NOTE 15—These data may not match similar data from mechanical tips (see 1.3).

This standard is subject to revision at any time by the responsible technical committee and must be reviewed every five years and if necessary, either reapproved or withdrawn. Your comments are invited either for revision of this standard or for additional standards and should be addressed to ASTM Headquarters. Your comments will receive careful consideration at a meeting of the responsible technical committee, which you may attend. If you feel that your comments have not received a fair hearing, you should also present them to the ASTM Committee on Standards, 1916 Race St., Philadelphia, Pa. 19103.

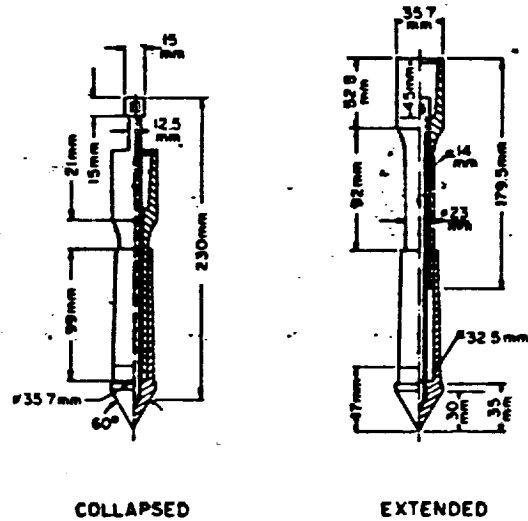

FIG. 1 Example of a Mechanical Cone Penetrometer Tip (Dutch Mantle Cone).



Standard Method for PENETRATION TEST AND SPLIT-BARREL SAMPLING OF SOILS¹

This standard is issued under the fixed designation D 1586; the number immediately following the designation indicates the year of original adoption or, in the case of revision, the year of last revision. A number in parentheses indicates the year of last revision. A superscript epsilon (ϵ) indicates an editorial change since the last revision or reapproval.

This method has been approved for use by agencies of the Department of Defense and for listing in the DOD Index of Specifications and Standards.

1. Scope

1.1 This method describes the procedure, generally known as the Standard Penetration Test (SPT), for driving a split-barrel sampler to obtain a representative soil sample and a measure of the resistance of the soil to penetration of the sampler.

1.2 This standard may involve hazardous materials, operations, and equipment. This standard does not purport to address all of the safety problems associated with its use. It is the responsibility of whoever uses this standard to consult and establish appropriate safety and health practices and determine the applicability of regulatory limitations prior to use. For a specific precautionary statement, see 5.4.1.

1.3 The values stated in inch-pound units are to be regarded as the standard.

2. Applicable Documents

2.1 ASTM Standards:

- D 2487 Test Method for Classification of Soils for Engineering Purposes²
- D 2488 Practice for Description and Identification of Soils (Visual-Manual Procedure)²
- D 4220 Practices for Preserving and Transporting Soil Samples²

3. Descriptions of Terms Specific to This Standard

3.1 *anvil*—that portion of the drive-weight assembly which the hammer strikes and through which the hammer energy passes into the drill rods.

3.2 *cathead*—the rotating drum or windlass in the rope-cathead lift system around which the operator wraps a rope to lift and drop the hammer by successively tightening and loosening the rope turns around the drum.

3.3 *drill rods*—rods used to transmit downward force and torque to the drill bit while drilling a borehole.

3.4 *drive-weight assembly*—a device consisting of the hammer, hammer fall guide, the anvil, and any hammer drop system.

3.5 *hammer*—that portion of the drive-weight assembly consisting of the 140 ± 2 lb (63.5 \pm 0.9 kg) impact weight which is successively dropped to provide the energy that accomplishes the sampling and penetration.

3.6 *hammer drop system*—that portion of the drive-weight assembly by which the operator accomplishes the lifting and dropping of the hammer to produce the blow.

3.7 *hammer fall guide*—that part of the drive-weight assembly used to guide the fall of the hammer.

3.8 *N-value*—the blowcount representative of the penetration resistance of the soil. The N-value, reported in blows per foot, equals the sum of the number of blows required to drive the sampler over the depth interval of 6 to 18 in. (150 to 450 mm) (see 7.3).

3.9 ΔN —the number of blows obtained from each of the 6-in. (150-mm) intervals of sample penetration (see 7.3).

3.10 *number of rope turns*—the total contact angle between the rope and the cathead at the

¹This method is under the jurisdiction of ASTM Committee D-18 on Soil and Rock and is the direct responsibility of Subcommittee D18.02 on Sampling and Related Field Tests for Soil Investigations.

Current edition approved Sept. 11, 1984. Published November 1984. Originally published as D 1586 - 58 T. Last previous edition D 1586 - 67 (1974).

²Annual Book of ASTM Standards, Vol 04.08.

loosening of the operator's rope slackening to drop the hammer, divided by 360° (see Fig. 1).

1.11 *sampling rods*—rods that connect the drive-weight assembly to the sampler. Drill rods or others used for this purpose.

1.12 *SPT*—abbreviation for Standard Penetration Test, a term by which engineers commonly refer to this method.

4. Significance and Use

4.1 This method provides a soil sample for classification purposes and for laboratory tests appropriate for soil obtained from a sampler that produces large shear strain disturbance in the soil.

4.2 This method is used extensively in a great variety of geotechnical exploration projects. Many local correlations and widely published correlations which relate SPT blowcount, or *N*-value, and the engineering behavior of earthworks and foundations are available.

5. Apparatus

5.1 *Drilling Equipment*—Any drilling equipment that provides at the time of sampling a steady clean open hole before insertion of the sampler and ensures that the penetration test is performed on undisturbed soil shall be acceptable. The following pieces of equipment have proven to be suitable for advancing a borehole through subsurface conditions.

5.1.1 *Drag, Chopping, and Fishtail Bits*, less than 6.5 in. (162 mm) and greater than 2.2 in. (56 mm) in diameter may be used in conjunction with open-hole rotary drilling or casing-advance-ment drilling methods. To avoid disturbance of the underlying soil, bottom discharge bits are not permitted; only side discharge bits are permitted.

5.1.2 *Roller-Cone Bits*, less than 6.5 in. (162 mm) and greater than 2.2 in. (56 mm) in diameter may be used in conjunction with open-hole rotary drilling or casing-advance-ment drilling methods if the drilling fluid discharge is deflected.

5.1.3 *Hollow-Stem Continuous Flight Augers*, with or without a center bit assembly, may be used to drill the boring. The inside diameter of the hollow-stem augers shall be less than 6.5 in. (162 mm) and greater than 2.2 in. (56 mm).

5.1.4 *Solid Continuous Flight Bucket and Spoon Augers*, less than 6.5 in. (162 mm) and greater than 2.2 in. (56 mm) in diameter may be used if the soil on the side of the boring does not

cause samp

5.2 rods samp

plunging

tial) s

"A" r

eter o

of 1%

No

indicat

"A" s

neglig

100 ft

5.3

be cor

Fig. 2

and sh

dentec

a cons

perm

record

is per

penetr

Note

that N-

lines a

5.4

5.4.1

weigh

solid r,

the an

is drop

free fal

cathead

impede

assemb

Note

be perm

spector

5.4.2

trip, se

systems

ratus w

while r

5.5

as label

ground

vided i

project

AND SPLIT-BARREL SAMPLING OF

1586; the number immediately following the designation indicates the year of last revision. A number in parentheses indicates the year of last approval since the last revision or approval.

the Department of Defense and for listing in the DOD Index of Specifications

mer by successively tightening and loosening the rope turns around the drum.

3.3 *drill rods*—rods used to transmit downward force and torque to the drill bit while drilling a borehole.

3.4 *drive-weight assembly*—a device consisting of the hammer, hammer fall guide, the rod, and any hammer drop system.

3.5 *hammer*—that portion of the drive-weight assembly consisting of the 140 ± 2 lb (63.5 \pm 1 kg) impact weight which is successively lifted and dropped to provide the energy that accomplishes the sampling and penetration.

3.6 *hammer drop system*—that portion of the drive-weight assembly by which the hammer accomplishes the lifting and dropping of the hammer to produce the blow.

3.7 *hammer fall guide*—that part of the drive-weight assembly used to guide the fall of the hammer.

3.8 *N-value*—the blowcount representation of the penetration resistance of the soil. The N value, reported in blows per foot, equals the number of blows required to drive the sampler over the depth interval of 6 to 12 in. (150 to 450 mm) (see 7.3).

3.9 ΔN —the number of blows obtained for each of the 6-in. (150-mm) intervals of penetration (see 7.3).

3.10 *number of rope turns*—the total angle between the rope and the cashed end of

¹ This method is under the jurisdiction of ASTM Committee D-18 on Soil and Rock and is the direct responsibility of Subcommittee D18.02 on Sampling and Related Field Tests for Soil Investigations.

Current edition approved Sept. 11, 1964. Published October 1964. Originally published as D 1586 - 58 T. Last previous edition D 1586 - 67 (1974).

² Annual Book of ASTM Standards, Vol. 04.08

beginning of the operator's rope slackening to drop the hammer, divided by 360° (see Fig. 1).

3.11 *sampling rods*—rods that connect the drive-weight assembly to the sampler. Drill rods are often used for this purpose.

3.12 *SPT*—abbreviation for Standard Penetration Test, a term by which engineers commonly refer to this method.

4. Significance and Use

4.1 This method provides a soil sample for identification purposes and for laboratory tests appropriate for soil obtained from a sampler that may produce large shear strain disturbance in the sample.

4.2 This method is used extensively in a great many of geotechnical exploration projects. Many local correlations and widely published correlations which relate SPT blowcount, or *N*-value, and the engineering behavior of earth-works and foundations are available.

5. Apparatus

5.1 *Drilling Equipment*—Any drilling equipment that provides at the time of sampling a clean open hole before insertion of the sampler and ensures that the penetration test is performed on undisturbed soil shall be acceptable. The following pieces of equipment have proven to be suitable for advancing a borehole to various subsurface conditions.

5.1.1 *Drag, Chopping, and Fishtail Bits*, less than 6.5 in. (162 mm) and greater than 2.2 in. (56 mm) in diameter may be used in conjunction with open-hole rotary drilling or casing-advance-ment drilling methods. To avoid disturbance of underlying soil, bottom discharge bits are not permitted; only side discharge bits are permitted.

5.1.2 *Roller-Cone Bits*, less than 6.5 in. (162 mm) and greater than 2.2 in. (56 mm) in diameter may be used in conjunction with open-hole rotary drilling or casing-advance-ment drilling methods if the drilling fluid discharge is deflected.

5.1.3 *Narrow-Stem Continuous Flight Augers*, with or without a center bit assembly, may be used to drill the boring. The inside diameter of narrow-stem augers shall be less than 6.5 in. (162 mm) and greater than 2.2 in. (56 mm).

5.1.4 *Solid, Continuous Flight, Bucket and Shell Augers*, less than 6.5 in. (162 mm) and greater than 2.2 in. (56 mm) in diameter may be used if the soil on the side of the boring does not

D 1586

cave onto the sampler or sampling rods during sampling.

5.2 *Sampling Rods*—Flush-joint steel drill rods shall be used to connect the split-barrel sampler to the drive-weight assembly. The sampling rod shall have a stiffness (moment of inertia) equal to or greater than that of parallel wall "A" rod (a steel rod which has an outside diameter of 1½ in. (41.2 mm) and an inside diameter of 1¼ in. (28.5 mm)).

NOTE 1—Recent research and comparative testing indicates the type rod used, with stiffness ranging from "A" size rod to "N" size rod, will usually have a negligible effect on the *N*-values to depths of at least 100 ft (30 m).

5.3 *Split-Barrel Sampler*—The sampler shall be constructed with the dimensions indicated in Fig. 2. The driving shoe shall be of hardened steel and shall be replaced or repaired when it becomes dented or distorted. The use of liners to produce a constant inside diameter of 1½ in. (35 mm) is permitted, but shall be noted on the penetration record if used. The use of a sample retainer basket is permitted, and should also be noted on the penetration record if used.

NOTE 2—Both theory and available test data suggest that *N*-values may increase between 10 to 30% when liners are used.

5.4 Drive-Weight Assembly

5.4.1 *Hammer and Anvil*—The hammer shall weigh 140 ± 2 lb (63.5 \pm 1 kg) and shall be a solid rigid metallic mass. The hammer shall strike the anvil and make steel on steel contact when it is dropped. A hammer fall guide permitting a free fall shall be used. Hammers used with the cathead and rope method shall have an unimpeded overlift capacity of at least 4 in. (100 mm). For safety reasons, the use of a hammer assembly with an internal anvil is encouraged.

NOTE 3—It is suggested that the hammer fall guide be permanently marked to enable the operator or inspector to judge the hammer drop height.

5.4.2 *Hammer Drop System*—Rope-cathead, trip, semi-automatic, or automatic hammer drop systems may be used, providing the lifting apparatus will not cause penetration of the sampler while re-engaging and lifting the hammer.

5.5 *Accessory Equipment*—Accessories such as labels, sample containers, data sheets and groundwater level measuring devices shall be provided in accordance with the requirements of the project and other ASTM standards.

6. Drilling Procedure

6.1 The boring shall be advanced incrementally to permit intermittent or continuous sampling. Test intervals and locations are normally stipulated by the project engineer or geologist. Typically, the intervals selected are 5 ft (1.5 m) or less in homogeneous strata with test and sampling locations at every change of strata.

6.2 Any drilling procedure that provides a suitably clean and stable hole before insertion of the sampler and assures that the penetration test is performed on essentially undisturbed soil shall be acceptable. Each of the following procedures have proven to be acceptable for some subsurface conditions. The subsurface conditions anticipated should be considered when selecting the drilling method to be used.

6.2.1 Open-hole rotary drilling method.

6.2.2 Continuous flight hollow-stem auger method.

6.2.3 Wash boring method.

6.2.4 Continuous flight solid auger method.

6.3 Several drilling methods produce unacceptable borings. The process of jetting through an open tube sampler and then sampling when the desired depth is reached shall not be permitted. The continuous flight solid auger method shall not be used for advancing the boring below a water table or below the upper confining bed of a confined non-cohesive stratum that is under artesian pressure. Casing may not be advanced below the sampling elevation prior to sampling. Advancing a boring with bottom discharge bits is not permissible. It is not permissible to advance the boring for subsequent insertion of the sampler solely by means of previous sampling with the SPT sampler.

6.4 The drilling fluid level within the boring or hollow-stem augers shall be maintained at or above the in situ groundwater level at all times during drilling, removal of drill rods, and sampling.

7. Sampling and Testing Procedure

7.1 After the boring has been advanced to the desired sampling elevation and excessive cuttings have been removed, prepare for the test with the following sequence of operations.

7.1.1 Attach the split-barrel sampler to the sampling rods and lower into the borehole. Do

not allow the sampler to drop onto the soil to be sampled.

7.1.2 Position the hammer above and rest the anvil to the top of the sampling rods. This may be done before the sampling rods and sampler are lowered into the borehole.

7.1.3 Rest the dead weight of the sampler, rods, anvil, and drive weight on the bottom of the boring and apply a seating blow. If excessive cuttings are encountered at the bottom of the boring, remove the sampler and sampling rods from the boring and remove the cuttings.

7.1.4 Mark the drill rods in three successive 6-in. (0.15-m) increments so that the advance of the sampler under the impact of the hammer can be easily observed for each 6-in. (0.15-m) increment.

7.2 Drive the sampler with blows from the 140-lb (63.5-kg) hammer and count the number of blows applied in each 6-in. (0.15-m) increment until one of the following occurs:

7.2.1 A total of 50 blows have been applied during any one of the three 6-in. (0.15-m) increments described in 7.1.4.

7.2.2 A total of 100 blows have been applied.

7.2.3 There is no observed advance of the sampler during the application of 10 successive blows of the hammer.

7.2.4 The sampler is advanced the complete 18 in. (0.45 m) without the limiting blow count occurring as described in 7.2.1, 7.2.2, or 7.2.3.

7.3 Record the number of blows required to effect each 6 in. (0.15 m) of penetration or fraction thereof. The first 6 in. is considered to be a seating drive. The sum of the number of blows required for the second and third 6 in. of penetration is termed the "standard penetration resistance", or the "N-value". If the sampler is driven less than 18 in. (0.45 m), as permitted in 7.2.1, 7.2.2, or 7.2.3, the number of blows per each complete 6-in. (0.15-m) increment and for each partial increment shall be recorded on the boring log. For partial increments, the depth of penetration shall be reported to the nearest 1/8 in. (25 mm), in addition to the number of blows. If the sampler advances below the bottom of the boring under the static weight of the drill rods or the weight of the drill rods plus the static weight of the hammer, this information should be noted on the boring log.

7.4 The raising and dropping of the

140-lb (63.5-kg) hammer shall be accomplished using one of the following two methods:

7.4.1 By using a trip, automatic, or semi-automatic hammer drop system which lifts the 140-lb (63.5-kg) hammer and allows it to drop 30 ± 0.6 in. (0.76 m ± 25 mm) unimpeded.

7.4.2 By using a cathead to pull a rope attached to the hammer. When the cathead and rope method is used the system and operation shall conform to the following:

7.4.2.1 The cathead shall be essentially free of oil, grease and have a diameter in the range of 6 to 10 in. (150 to 250 mm).

7.4.2.2 The cathead should be operated at a minimum speed of rotation of 100 RPM, or the approximate speed of rotation shall be reported on the boring log.

7.4.2.3 No more than 2 1/2 rope turns on the cathead may be used during the performance of the penetration test, as shown in Fig. 1.

Note 4—The operator should generally use either 1/2 or 3/4 rope turns, depending upon whether or not the rope comes off the top (1 1/2 turns) or the bottom (3/4 turns) of the cathead. It is generally known and accepted that 2 1/2 or more rope turns considerably impairs the fall of the hammer and should not be used to perform the test. The cathead rope should be maintained in a relatively dry, clean, and unfayed condition.

7.4.2.4 For each hammer blow, a 30-in. (0.76-m) lift and drop shall be employed by the operator. The operation of pulling and throwing the rope shall be performed rhythmically without holding the rope at the top of the stroke.

7.5 Bring the sampler to the surface and open. Record the percent recovery or the length of sample recovered. Describe the soil samples recovered as to composition, color, stratification, and condition, then place one or more representative portions of the sample into sealable moisture-proof containers (jars) without ramming or distorting any apparent stratification. Seal each container to prevent evaporation of soil moisture. Affix labels to the containers bearing job designation, boring number, sample depth, and the blow count per 6-in. (0.15-m) increment. Protect the samples against extreme temperature changes. If there is a soil change within the sampler, make a jar for each stratum and note its location in the sampler barrel.

8. Report

8.1 Drilling information shall be recorded in the field and shall include the following:

8.1.1
8.1.2
8.1.3
8.1.4
8.1.5
boring
8.1.6
and co
8.1.7
8.1.8
boring
8.1.9
8.1.10
depth
and m
made
8.1.11
8.1.12
of bor
8.1.13
samp
8.1.14
diam
8.1.15
samp
8.1.16
8.1.17
reco
ing
8.1.18
num
8.1.19
8.1.20
8.1.21
len
g
par
9.1
ha
arc
ad
ren
tha
A
a
ex
ca
or
se

ORIGINAL PAGE IS OF POOR QUALITY

not allow the sampler to drop onto the soil to be sampled.

7.1.2 Position the hammer above and under the anvil to the top of the sampling rod. This may be done before the sampling rods and sampler are lowered into the borehole.

7.1.3 Rest the dead weight of the sampler, rods, anvil, and drive weight on the bottom of the boring and apply a seating blow. If excessive cuttings are encountered at the bottom of the boring, remove the sampler and sampling rod from the boring and remove the cuttings.

7.1.4 Mark the drill rods in three successive 6-in. (0.15-m) increments so that the advance of the sampler under the impact of the hammer can be easily observed for each 6-in. (0.15-m) increment.

7.2 Drive the sampler with blows from the 140-lb (63.5-kg) hammer and count the number of blows applied in each 6-in. (0.15-m) increment until one of the following occurs:

7.2.1 A total of 50 blows have been applied during any one of the three 6-in. (0.15-m) increments described in 7.1.4.

7.2.2 A total of 100 blows have been applied during any one of the three 6-in. (0.15-m) increments described in 7.1.4.

7.2.3 There is no observed advance of the sampler during the application of 10 successive blows of the hammer.

7.2.4 The sampler is advanced the sampler 18 in. (0.45 m) without the limiting blow count occurring as described in 7.2.1, 7.2.2, or 7.2.3.

7.3 Record the number of blows required to effect each 6 in. (0.15 m) of penetration or fraction thereof. The first 6 in. is considered as the seating drive. The sum of the number of blows required for the second and third 6 in. of penetration is termed the "standard penetration resistance", or the "N-value". If the sampler is driven less than 18 in. (0.45 m), as permitted in 7.2.1, 7.2.2, or 7.2.3, the number of blows per each complete 6-in. (0.15-m) increment and for each partial increment shall be recorded on the boring log. For partial increments, the depth of penetration shall be reported to the nearest 1/8 in. (25 mm), in addition to the number of blows.

If the sampler advances below the bottom of the boring under the static weight of the drill rods plus the weight of the drill rods plus the static weight of the hammer, this information should be recorded on the boring log.

7.4 The raising and dropping of the sampler

shall be accomplished using either of the following two methods:

7.4.1 By using a trip, automatic, or semi-automatic hammer drop system which lifts the 140-lb (63.5-kg) hammer and allows it to drop 30 ± 1.0 in. (0.76 m ± 25 mm) unimpeded.

7.4.2 By using a cathead to pull a rope attached to the hammer. When the cathead and rope method is used the system and operation shall conform to the following:

7.4.2.1 The cathead shall be essentially free of rust, oil, or grease and have a diameter in the range of 6 to 10 in. (150 to 250 mm).

7.4.2.2 The cathead should be operated at a minimum speed of rotation of 100 RPM, or the approximate speed of rotation shall be reported on the boring log.

7.4.2.3 No more than 2 1/4 rope turns on the cathead may be used during the performance of the penetration test, as shown in Fig. 1.

Note 4—The operator should generally use either 1 1/2 or 2 1/4 rope turns, depending upon whether or not the rope comes off the top (1 1/2 turns) or the bottom (2 1/4 turns) of the cathead. It is generally known and accepted that 2 1/4 or more rope turns considerably impairs the fall of the hammer and should not be used to perform the test. The cathead rope should be maintained in a relatively dry, clean, and unfrayed condition.

7.4.2.4 For each hammer blow, a 30-in. (0.76-m) fall and drop shall be employed by the operator. The operation of pulling and throwing the rope shall be performed rhythmically without jerking the rope at the top of the stroke.

7.5 Bring the sampler to the surface and open. Record the percent recovery or the length of sample recovered. Describe the soil samples recovered as to composition, color, stratification, and condition, then place one or more representative portions of the sample into sealable moisture-proof containers (jars) without ramming or distorting any apparent stratification. Seal each container to prevent evaporation of soil moisture. Affix labels to the containers bearing the designation, boring number, sample depth, and the blow count per 6-in. (0.15-m) increment. Protect the samples against extreme temperature changes. If there is a soil change within the sample, make a jar for each stratum and note the change in the sampler barrel.

7.6 Drilling information shall be recorded in the field and shall include the following:

8.1.1 Name and location of job,

8.1.2 Names of crew,

8.1.3 Type and make of drilling machine,

8.1.4 Weather conditions,

8.1.5 Date and time of start and finish of boring.

8.1.6 Boring number and location (station and coordinates, if available and applicable).

8.1.7 Surface elevation, if available,

8.1.8 Method of advancing and cleaning the boring.

8.1.9 Method of keeping boring open,

8.1.10 Depth of water surface and drilling depth at the time of a noted loss of drilling fluid, and time and date when reading or notation was made,

8.1.11 Location of strata changes,

8.1.12 Size of casing, depth of cased portion of boring.

8.1.13 Equipment and method of driving sampler,

8.1.14 Type sampler and length and inside diameter of barrel (note use of liners),

8.1.15 Size, type, and section length of the sampling rods, and

8.1.16 Remarks.

8.2 Data obtained for each sample shall be recorded in the field and shall include the following:

8.2.1 Sample depth and, if utilized, the sample number,

8.2.2 Description of soil,

8.2.3 Strata changes within sample,

8.2.4 Sampler penetration and recovery lengths, and

8.2.5 Number of blows per 6-in. (0.15-m) or partial increment.

9. Precision and Bias

9.1 Variations in N-values of 100% or more have been observed when using different standard penetration test apparatus and drillers for adjacent borings in the same soil formation. Current opinion, based on field experience, indicates that when using the same apparatus and driller, N-values in the same soil can be reproduced with a coefficient of variation of about 10%.

9.2 The use of faulty equipment, such as an extremely massive or damaged anvil, a rusty cathead, a low speed cathead, an old, oily rope, or massive or poorly lubricated rope sheaves can significantly contribute to differences in N-values

obtained between operator-drill rig systems.
9.3 The variability in *N*-values produced by different drill rigs and operators may be reduced by measuring that part of the hammer energy

delivered into the drill rods from the sample and adjusting *V* on the basis of comparative energy. A method for energy measurement and *N*-value adjustment is currently under development.

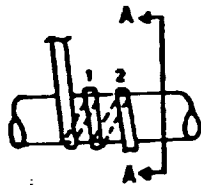

(a) counter-clockwise rotation approximately 1 1/4 turns

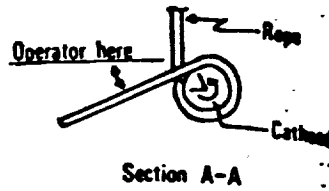

Section A-A

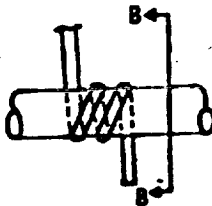

(b) clockwise rotation approximately 2 1/4 turns



Section B-B

FIG. 1 Definitions of the Number of Rope Turns and the Angle for (a) Counter-clockwise Rotation and (b) Clockwise Rotation of the Cathode

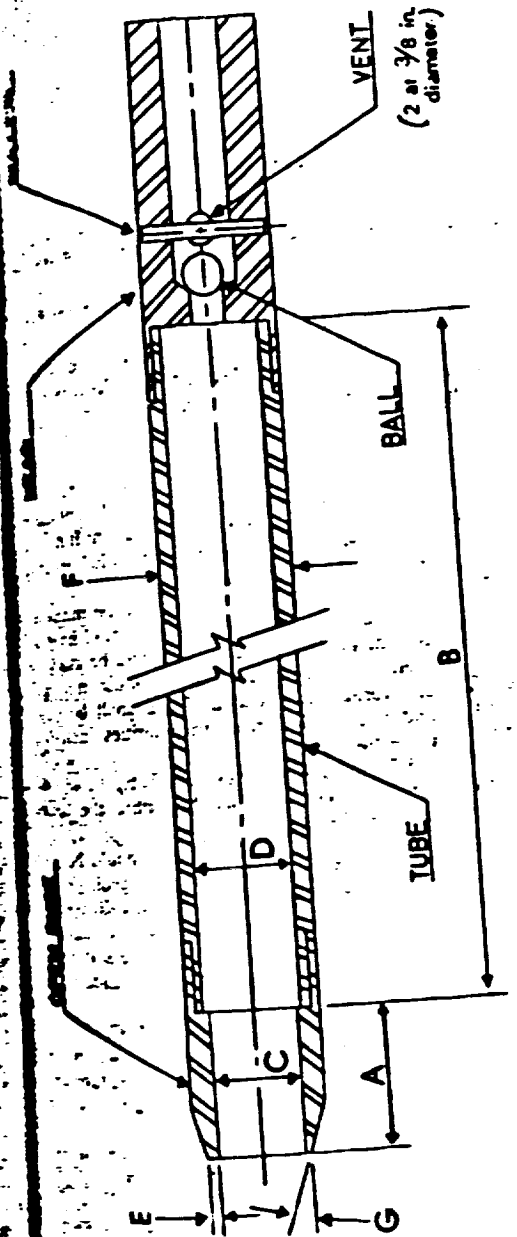

ORIGINAL PAGE IS OF POOR QUALITY

delivered into the drill rods from the sampler and adjusting N on the basis of comparative energy. A method for energy measurement and N value adjustment is currently under development.

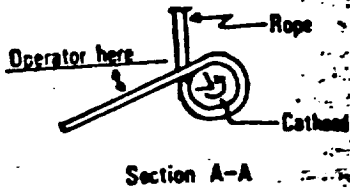

Section A-A

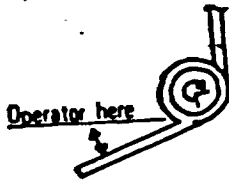

Section B-B

1 The Angle for (a) Counterclockwise Rotation and (b) Clockwise Rotation of the Cathode

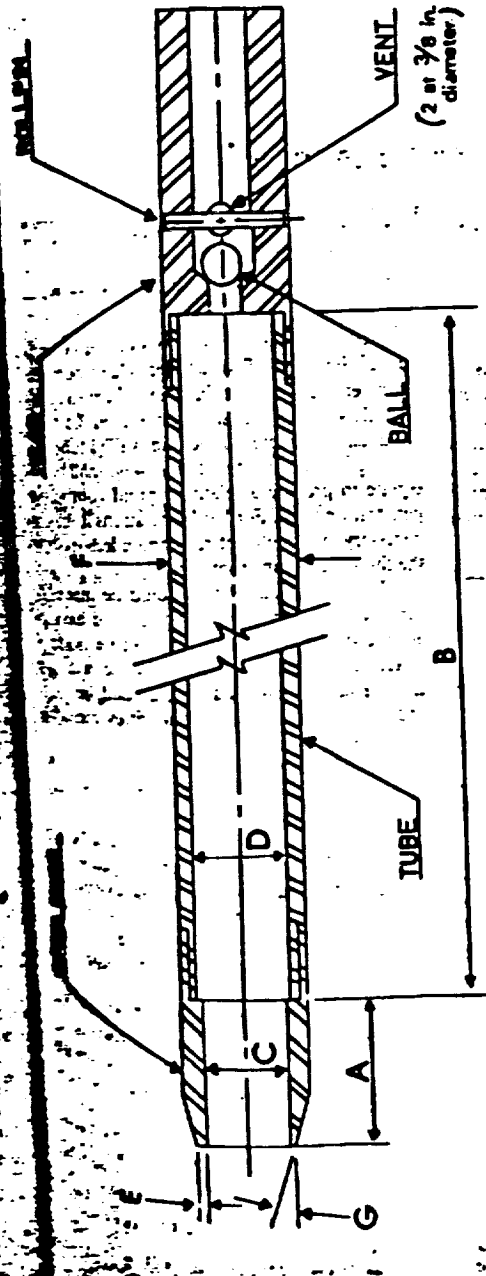

- A = 1.0 to 2.0 in. (25 to 50 mm)
- B = 18.0 to 20.0 in. (457 to 508 mm)
- C = 1.375 ± 0.005 in. (34.93 ± 0.13 mm)
- D = 1.41 ± 0.05 - 0.00 in. (35.7 ± 1.3 - 0.0 mm)
- E = 0.10 ± 0.02 in. (2.54 ± 0.25 mm)
- F = 2.00 ± 0.05 - 0.00 in. (50.8 ± 1.3 - 0.0 mm)
- G = 1.0" to 2.1"

The 1/2 in. (12.7 mm) inside diameter split barrel may be used with a 16-gage wall thickness split liner. The processing end of the drive shoe may be slightly rounded. Metal or plastic retainers may be used to retain soil samples.

FIG. 3 Split-Barrel Sampler

The American Society for Testing and Materials takes no position regarding the validity of any patent rights asserted in connection with any item mentioned in this standard. Users of this standard are expressly advised that determination of the validity of any such patent rights, and the risk of infringement of such rights, are entirely their own responsibility.

This standard is subject to revision at any time by the responsible technical committee and must be reviewed every five years and if not revised, either reapproved or withdrawn. Your comments are invited either for revision of this standard or for additional standards and should be addressed to ASTM Headquarters. Your comments will receive careful consideration at a meeting of the responsible technical committee, which you may attend if you feel that your comments have not received a fair hearing. You should make your views known to the ASTM Committee on Standards, 1916 Race St., Philadelphia, Pa. 19103.

CONTENTS

	<u>Page</u>
SUMMARY	3
PREFACE	5
PART I: INTRODUCTION	9
Background	9
Purpose and Scope	9
Approach	10
PART II: EQUIPMENT AND MATERIALS	12
High Vacuum Facility	12
Lunar Soil Simulant	12
Test Containers	12
PART III: SPECIMEN PREPARATION AND TEST PROCEDURES	14
Test Specimens	14
Specimen Conditioning	14
Container Support in the Working Chamber	14
PART IV: DISCUSSION AND PRESENTATION OF TEST RESULTS	16
Preliminary Tests	16
Heating Effects on Simulant	16
Pump Down and Outgassing Tests	17
Nitrogen Overlay Tests	20
Theoretical Evaluation	22
PART V: CONCLUSIONS AND RECOMMENDATIONS	23
REFERENCES	24
TABLES I and II	
FIGURES 1-16	
APPENDIX A - DIFFUSION OF GAS THROUGH A POROUS MEDIUM	

LUNAR SOIL STIMULANT STUDY, PHASE B

PART I, OUTGASSING CHARACTERISTICS

PART I: INTRODUCTION

Background

1. A study to develop a lunar soil simulant whose physical behavior in the earth's gravity field approximates the behavior of lunar soil in the reduced gravity field of the moon was initiated in Fiscal Year 1966. The first phase of the study which was completed and reported(1)* in April 1966, was to develop a material, designated Type A Lunar Soil Simulant, which, in an environment varying from atmospheric to 10 torr, would have certain prescribed properties. The material developed under this phase was granular and was composed of unweathered diabase rock, crushed and processed to fall within the gradation band shown on Figure 1. Other pertinent properties included the following:

- a. Bulk density (free fall state) 1370-1450 kg/m³ (85-90 lb/ft³)
- b. Particle specific gravity 3.02-3.16
- c. Light reflectivity (albedo) 0.07-0.09
- d. Sinkage under simulated astronaut's weight
of 0.352 kg/cm² (5 lbs/in.²) 2.5-5 cm (1-2 in.)

2. The second phase of the overall study requires a more severe environment for the testing. The Type A simulant developed during the initial phase of the study was used in the Phase B investigation. The required vacuum level for the Phase B study varies from the roughing range to approximately 1×10^{-5} torr. Should the Type A simulant prove unacceptable in the Phase B environment, it will be modified to approximate certain outgassing and thermal properties established from earlier studies. The Phase B investigation is broken into two parts: (1) outgassing characteristics and (2) thermal properties. Phase C of the overall study will test the lunar soil simulant in an environment of 10^{-8} torr and below. This vacuum level approaches that of the lunar surface and will provide a severe test of the ability of the lunar soil simulant to meet prescribed properties.

Purpose and Scope

3. The purpose of this report is to present the outgassing characteristics of the simulant produced under the first phase study. The report is limited to a discussion of the results of conditioning, outgassing, and overlay experiments on the crushed

* Raised numbers in parenthesis refer to references.

diabase material. Problem areas that should be overcome so that man-rated vacuum chambers may be evacuated to a specific pressure with a minimum of delay due to simulant outgassing are discussed. The results reported herein constitute the first part of Lunar Soil Simulant Study, Phase B, described above.

Approach

4. The high vacuum facility available at these Laboratories was used to determine the outgassing characteristics of the simulant. The tests included the following:

- a. Length of time required to pump down to a specific pressure,
- b. Outgassing rate at the specific pressure, and
- c. The outgassing characteristics of the simulant under repeated pump cycles of pump down and repressurization.

5. The experimental approach to accomplish the work in this study involved consideration of the following behavior characteristics of the simulant in the Phase B environment:

- a. Because water vapor is the most difficult source of outgassing to eliminate, the simulant should be stored so as to exclude moisture.
- b. Conditioning of the simulant should be so designed as to remove as much adsorbed water from the interior of the material as possible prior to placement in the vacuum chamber.

6. The techniques employed included consideration of the following:

- a. Conditioning of the materials was accomplished by heating all quantities of the material in air. The effectiveness of the program of preconditioning was evaluated by a series of plots relating pressure to time. Analysis of this data should provide valuable insight into gas loads to be anticipated for large quantities of the simulant.
- b. The effect of nitrogen overlays between successive pump down was examined to evaluate overall system characteristics under simulated day to day operations.
- c. Special emphasis was placed on describing pump down in the roughing region so that a complete picture of gas load as a function of time could be obtained.

d. A closed form solution of the one-dimensional diffusion equation was obtained, and the theoretical relationship between pressure and depth within a mass of simulant was plotted.

PART II: EQUIPMENT AND MATERIALS

High Vacuum Facility

7. The high vacuum facility used for this study consists of three major components: forepump, diffusion pump, and working chamber. The mechanical forepump, rated at 7.1 liters per second (15 cfm), provides initial or rough pumping down to a pressure of about 10^{-2} torr, at which point the diffusion pump is put into the system by opening a pneumatically operated gate valve. A water cooled chevron baffle is installed between the diffusion pump and the chamber to minimize backstreaming. A 15-cm (6-in.) oil diffusion pump with a nominal pumping speed of 1440 liters per second (3050-cfm) provides the capability of attaining the high vacuum range. The pumping speed of the system is affected by conductance losses: (a) at the entrance to the throat, (b) in the throat, (c) in the gate valve, and (d) in the chevron baffle. The losses combine to reduce the net pumping speed to approximately 315 liters per second (668-cfm). The working chamber consists of a nominal 46-cm (18-in.) stainless steel feedthrough collar surmounted by a 46-cm (18-in.) diameter by 46-cm (18-in.) high pyrex bell jar. A butyl rubber gasket provides the principle bell jar seal.

8. Pressure is monitored by three gauges. A thermocouple gauge placed in the roughing line provides readings in the roughing range, and is used primarily to indicate when the diffusion pump can be activated. A cold cathode ionization gauge provides pressure measurement capability down to the mid 10^{-7} torr range. The gauge is mounted in the throat section between the working chamber and the baffle, and will therefore indicate a pressure somewhat lower than the pressure in the working area. A dual chamber ionization gauge is mounted in the feedthrough collar and provides pressure readings in the working chamber from atmosphere down to the mid 10^{-4} torr range. Both ionization gauges are connected to a strip chart recorder which yields a continuous record of pressure versus time from atmosphere down to the ultimate pressure of the system.

Lunar Soil Simulant

9. The Type A simulant was used in the initial phase of this study and was stored in a polyethylene lined steel drum. The quantity to be tested was drawn from this stockpile. The moisture content of the stored simulant was less than 1% dry weight.

Test Containers

10. Four test containers were used in this program and are described more

fully in tabular form below. Each cylinder consists of a length of standard aluminum pipe cut to length and welded to an aluminum base plate. The four cylinders comprise two groups of containers based on nominal volume. The smaller volume A container was used for the majority of tests. The larger volume B containers were used for comparative tests to provide a basis for estimating gas loads based on either volume or surface area.

Summary of Container Dimensions

Test Containers	Diameter cm	Height cm	Cross Sectional Area cm ²	Volume cm ³	Weight of Simulant kg
A	10.16	10.16	81.07	823.67	1.18
B ₁	20.16	9.255	319.23	2635.23	3.82
B ₂	12.07	25.40	114.42	2906.27	3.82
B ₃	15.24	15.24	183.36	2784.41	3.82

Conversion Factor

cm x 0.394 = inches
 cm² x 0.155 = square inches
 cm³ x 0.061 = cubic inches
 kg x 2.203 = pounds

PART III: SPECIMEN PREPARATION AND TEST PROCEDURES

Test Specimens

11. The Type A simulant taken directly from the stockpile was loaded into the test container through a cone-shaped hopper supplied with a quick opening valve. The distance from the valve to the bottom of a container is 33-cm (13-in.). The simulant was allowed to fall freely into each container, but no other attempt was made to assure uniformity of placement density.

Specimen Conditioning

12. Simulant conditioning to a temperature of either 150° C or 325° C was accomplished in a 3.75 KW oven. With the single exception of the "unconditioned A" sample, all runs were made on conditioned material. For each test, the simulant was heated to a specified temperature for a specified length of time, deposited into the test container, and immediately placed in the working chamber. Pump down was started immediately on the hot material. Because pumping continues on material heated above room temperature, a condition approximating internal bakeout was developed.

13. The temperatures to which the simulant were heated provide a broad picture of the effect of preheating on simulant outgassing. The Aero Vac Corporation⁽²⁾ identified water vapor as the primary outgassing product at pressures on the order of 1×10^{-5} torr. The primary objective of the oven heating was to drive off hygroscopic moisture as well as the more tightly adsorbed water molecules. Vey and Nelson⁽³⁾ investigated the composition of the gas desorbed during the outgassing of four mineral powders and sands as a function of temperature. They concluded that the composition of the gas was approximately the same for all minerals tested and that the predominant constituent gas was water vapor. Furthermore, the total quantity of gas evolved increased with temperature to a maximum at about 400° C. The proportion of this total quantity attributable to water vapor also increased to a maximum at this temperature. From this evidence, it may be inferred that heating the simulant to temperatures in excess of 300° C will be beneficial to outgassing by supplying energy to remove the more tightly bound water molecules adsorbed on the simulant particles surfaces.

Container Support in the Working Chamber

14. Initially, the containers were placed in the vacuum chamber on a stainless steel plate that measured 40.6-cm (16-in.) in diameter. The plate served as a positive

protection for the pump should any geysering occur which would spill the simulant out of the container. When it was verified that geysering does not present a problem when pumping occurs on heated material, the plate was replaced with a stainless steel mesh containing 0.64-cm (0.25-in.) openings. All of the 150° C runs were made on the mesh. Although some reduction in pumping speed was anticipated when the plate was used, the effect did not appear to be too significant.

PART IV: DISCUSSION AND PRESENTATION OF TEST RESULTS

Preliminary Tests

15. Before starting the test series, several preliminary pump downs were completed on unconditioned material to develop techniques for control of geysering, if needed. Geysering was observed repeatedly, but was easily controlled by bleeding dry nitrogen into the up to air valve. This technique raised the pressure in the chamber to a level above the critical geysering pressure (4-6 torr), and permitted the gas to escape from the simulant and be pumped away in a non-violent manner. The up to air valve could then be closed gradually and pump down proceeded without geysering. Geysering, when uncontrolled, could be quite violent. In some cases, geysered material was found adhering to the inside top surface of the bell jar, as well as throughout the working chamber and throat. Subsequent tests on conditioned material that did not geyser were handicapped because of erratic behavior from the cold cathode gauge. This behavior was attributed to arcing between the cathode and the anode of the gauge. It is believed that some of the fine dust emitted during geysering was electrostatically attracted to the electrodes, thus reducing the distance between gauge elements and causing premature discharges. After thorough cleaning with pumice, chemical solvent, and ultrasonic techniques, the gauge operation returned to normal and no abnormal behavior was observed thereafter.

Heating Effects on Simulant

16. A color change in the simulant became apparent after the material was heated to 325° C. X-ray diffraction analysis on samples of baked and unbaked simulant revealed essentially no compositional difference. It is believed that the heat caused Fe ions contained in the feldspar and pyroxene to change from combined ferrous and ferric iron to either all ferrous iron or all ferric iron. Such a change will generally cause a mineral to become lighter in color. In order to evaluate the magnitude of color change, samples of unconditioned, 150° C conditioned and 325° C conditioned material were subjected to Munsell color chart analysis. In addition to the color evaluation, light reflectivity measurements were taken on samples of unconditioned and 325° C conditioned simulant. There was no measurable difference in albedo within the accuracy of the photometer used. The results are summarized as follows:

Optical Property Change Due to Heating

Sample	Conditioning History	Munsell Color Description	Munsell Color Number	Albedo %
1	Unconditioned	Moderate Olive Gray	5Y 4/2	7.0
2	150° C	Dark Yellowish Brown	10YR 3/2	--
3	325° C	Dark Yellowish Brown	10YR 4/4	7.0

Pump Down and Outgassing Tests

17. General. Previous investigators have reported pump down times measured in hours for their studies. Vey and Nelson⁽³⁾, and Jaffe⁽⁴⁾, among others, required long pumping times to minimize the possibility of disturbing the soil structure during evacuation. Pump down times were long partly because of the outgassing of the fine mineral powders used and partly because testing was to be accomplished at a vacuum level approaching that of the lunar surface. Other investigators expended a great deal of effort to insure clean particle surfaces prior to testing. Conditioning of samples prior to testing have included chemical baths⁽⁵⁾, bakeout in vacuum⁽⁶⁾, ⁽⁷⁾, grinding in an inert atmosphere⁽⁸⁾, and cleavage of specimens in vacuum⁽⁹⁾. Although these techniques are necessary for testing in hard vacuum, they are not believed to be essential for tests to be accomplished at 1×10^{-5} torr.

18. Pump Down Tests. Figures 2 through 9 are a series of pressure versus time curves showing pump down times for the two temperatures used for conditioning and for the two quantities of simulant. Figures 2 and 3 show the pump down curves after roughing for the 1.2-kg (2.64-lb) sample for differing lengths of exposure to each of the conditioning temperatures. Figures 4 and 5 repeat these curves for the 3.8-kg (8.38-lb) samples placed in the B₁ container. Figures 6 and 7 are of the same type for the 3.8-kg (8.38-lb) sample placed in the B₂ container. Figure 8 compares the pump down times between the 1.2-kg (2.64-lb) and 3.8-kg (8.38-lb) samples baked at the 150° C temperature for 24 hours and for 64 hours. In Figure 8 the curves from Figures 2 through 7 are abstracted to show a band of values embracing the range of exposure times. Figure 9 presents a comparison of the pump down curves between the

two quantities of simulant exposed for 24 hours to each of the temperatures.

19. Conditioning Period. The results of the outgassing experiments are shown in Figures 2 through 9 and in Table I. Each of the figures show that, in general, as the period of exposure to the heated environment increases, the time required to attain a given pressure decreases. For each set of curves, however, the relative improvement for each increment of exposure time decreases. This suggests the possibility of optimizing exposure time relative to elapsed time necessary to reach the vacuum level desired. For the vacuum system used and for the quantities of simulant evacuated, the optimum conditioning time was estimated to be 24 hours.

20. Conditioning Temperature. The beneficial effect of heating the simulant to 325° C is apparent from a comparison of pairs of figures (Figure 2 with 3; 4 with 5; and 6 with 7) which reveals a significant reduction in pump down time required to reach any selected pressure. The higher temperature evidently introduces a greater amount of thermal energy into the mass causing the more tightly bound gas molecules to desorb more readily and be pumped out more quickly. These more tightly bound molecules are not activated to as great an extent by the lower temperature environment, and consequently bleed out over a longer period of time.

21. Reduction in Pumping Time Due to Heating. Figure 9 summarizes the effect of conditioning temperature at the optimum 24-hour exposure period for the three quantities of simulant. In all cases, pumping time required to reach 1×10^{-5} torr was reduced for samples exposed to 325° C relative to samples exposed to 150° C. The saving in time may be expressed in the form of a percentage reduction in time based on the longer period. In all cases, pumping time required to reach 1×10^{-5} torr was reduced by approximately 75% for the quantities exposed to the higher temperature. A similar comparison may be made between unconditioned simulant and heated simulant. In these cases, the savings in time amount to 98.5% for samples heated to 325° C and 93% for samples heated to 150° C. Obviously, even the lower temperature conditioning is effective in improving overall performance.

22. Reduction in Pumping Time Due to Conditioning Period. Figure 8 compares pump down curves for the different quantities of simulant exposed to an environment of 150° C for 24 hours and for 64 hours. Reference to this figure and to Table I shows some improvement in required pump down time for each quantity. The percentage reduction in time for the A and B₂ quantities are respectively 6 and 9%. However, the percentage reduction for the B₁ quantity is 24%. The wider container, B₁, apparently permits more efficient removal of gas because of the greater cross sectional area exposed to the vacuum environment. However, the reduction of time obtained due to the longer period of baking is not believed to be significant.

23. Analysis of Pump Down Curves. Analysis of the shapes of the pump down curves shown on Figure 8 helps to define the character of outgassing. The initial point

on each curve is the first pressure reading recorded after the diffusion pump was activated. The final points represents pressure readings when each test was terminated, and should not be interpreted as the ultimate pressure of the system for the given quantity of soil. The curves are reasonably linear through most of their lengths. The fact that the slopes are approximately parallel shows that the pumping rate is constant into the low 10^{-6} torr range for all quantities tested. The curves are non-linear at the start (indicating a heavy gas load which must be removed before steady state pumping can proceed), and at the end (indicating that both virtual and real system leakage is approaching the pumping capacity of the system).

24. Roughing Period. The length of time required to rough down before activation of the diffusion pump is an important indicator of the total time required to reach the specified pressure level. Table I lists the times required to reach each of four pressure levels from atmospheric pressure. The pressure level "Roughing" refers to the time at which the roughing pump was valved off and the diffusion pump was activated. In general, the corresponding pressure in the chamber at this time was on the order of 1 or 2×10^{-2} torr. It is apparent from the table that the roughing period is some function of the quantity of simulant used. Figure 10 presents comparative pump down times in the roughing regions for four quantities of simulant. The fact that the roughing period for the B₂ samples is intermediate between the B₁ and A quantities suggests a further relationship with cross sectional area and/or depths of material. In order to investigate this relationship, a third B quantity intermediate in depth between B₁ and B₂ was pumped down. The B₃ pump down curve appears to be inconsistent in that it does not fall between the curves for the extreme B containers. Time did not permit an evaluation of factors other than geometric shape and size. However a few qualitative observations may be made despite the apparent inconsistency. All quantities pumped down to 200 microns in essentially the same period of time. Thereafter, the A and B₂ samples pumped down to 80 microns in approximately the same time. On the other hand, the B₁ and B₃ samples diverged and required about one and a half times as long to reach the 80 micron pressure level. From 80 microns down to the pressure at which the diffusion pump was activated, all B quantities required substantially greater periods of pumping than the A quantity. An assessment of the effect of the container on outgassing in the roughing range was not possible at this time. However, the results indicate that simulant outgassing is primarily a roughing problem, and that any steps taken to augment roughing especially in the region from 100 microns on down should improve overall system performance.

25. Effect of Quantity of Simulant on Pumping Time. Curves showing the relationship between quantity of simulant and roughing time, time to 5×10^{-5} torr, time to 1×10^{-5} torr and time to 5×10^{-6} torr are shown in Figure 15. It should be noted that the curve for the roughing time is linear. This indicates that the pumping capacity required to pump down a chamber containing the simulant in a given time should be proportional to the quantity of simulant. The curves for the time to reach lower pressures are not linear but appear to approach linear behavior asymptotically for larger quantities of simulant. Consequently, an estimate of the pumping time required for each given quantity of simulant can be estimated if information concerning the size of the chamber in which it is to be used, pumping system for the chamber and

ultimate vacuum level of the empty chamber is given.

26. Outgassing Rate. The results of the outgassing rate calculations are shown on Table I and indicate clearly that the outgassing rate depends strongly on the amount of material since the outgassing rate for 1.2-kg (2.64 lb) of simulant (Container A) is less than that for 3.8-kg (8.38 lb) of simulant (Containers B₁ and B₂). The outgassing rate for the B₁ container is less than that for the B₂ container, indicating that depth of simulant is a more significant factor than exposed surface area. An explanation for this behavior is based on the discussion of the diffusion of gases through porous media given in Appendix A. From the curves it can be seen that the pressure is considerably higher at a depth of 25-cm (9.85-in.) than it is at a depth of 10-cm (3.94-in.), the approximate depths of the simulant in the B₂ and B₁ containers respectively. The deeper container has a reservoir of more gas which must be removed at any given pressure than does the shorter container and therefore has a higher outgassing rate. That is, more gas is removed from the simulant in the B₁ container at higher pressures so that the outgassing rate at 10⁻⁵ torr is less.

27. Simulant Behavior During Pump Down. The geysering referred to in paragraph 15 occurred only on material that had not been conditioned. It was characterized by violent upheaval of material and occurred at between 5 and 10 torr pressure. A second type of geysering was observed frequently on conditioned material placed in the B₂ container. The onset of geysering began when the chamber had been evacuated to about 100 to 300 torr. The phenomenon was not violent, and was manifested by the appearance of several small blow holes. In no case was the phenomenon violent enough to justify operation of the up to air valve. The overall pump down time was therefore unaffected by this type of geysering. The fact that the phenomenon occurred only for the 3.8-kg (8.38-lb) samples placed at a 10-cm (7.88-in.) depth suggests a dependence on depth rather than quantity of simulant.

28. Slumping of surface material was observed when the chamber had been evacuated to about the same pressure at which blow hole type geysering occurred. This phenomenon occurred only on material placed in the B₁ container, and only for samples placed with the top surface inclined at approximately the angle of repose. Pump down was unaffected by the disturbances. The fact that slumping occurred only on material placed in the container with the largest surface area suggests the possibility of spontaneous slides if large quantities of simulant are placed at too great a slope in a man-rated chamber.

Nitrogen Overlay Tests

Test Results

29. The overlay experimental results are shown on Figures 11 through 14.

These figures show the complete history of pressure as a function of time and include periods during which the chamber was let up to atmospheric pressure with dry nitrogen. The pressure versus time curves for similar samples pumped down without overlay are plotted on each figure for comparison. The effect of repeated overlays started at the bottom of the roughing range is shown on Figure 14.

30. The overlay experiments were originally designed to provide information as to how the simulant would behave under conditions approximating day to day operations in a man-rated chamber. The dramatic improvement in system performance was a bonus. The technique of nitrogen overlay was simply to pump down to a given pressure level, close the gate valve and then introduce dry nitrogen into the working chamber through the up-to-air valve. In all cases the pressure in the working chamber was atmospheric for the duration of the overlay period. Table II summarizes the data for eight overlay experiments. Variables tested include; duration of overlay, number of overlay periods, duration of pre-conditioning at 150° F and size of container. Each pumping period began at atmospheric pressure. The columns headed "Pump Down" indicate the length of time to reach each stated pressure and was measured from the time the mechanical pump was started. The columns headed "Total Time Elapsed" are accumulative time periods and include both previous overlay times and previous pumping history. In general, evacuation of the chamber after overlay proceeded so rapidly that the first reliable pressure reading could not be obtained until a pressure of about 1×10^{-5} torr had been reached. Figures 11 through 14 are pressure versus elapsed time curves for all test runs except A-24-1. The arrows indicate the pressure and time at which the chamber was let up to dry nitrogen for each overlay. Figures 11 through 13 present a comparison of 64 hour conditioning versus 24 hour conditioning for each quantity of simulant tested. Figure 14 shows that the time required to reach a given pressure level may be significantly reduced by letting the chamber up to dry nitrogen in the roughing stage and repeating the overlay process at frequent intervals. It is apparent from these results that pump down time to a given pressure level is reduced after a period of overlay, and that pressure level attained for a given elapsed time is lower than that which would have occurred had there been no overlay. It follows that improvement in system performance can be obtained by repeated overlays begun after completion of roughing, and that dry nitrogen overlays can be used as a technique of outgassing quantities of simulant material. These conclusions are emphasized by noting that normal pump down on A-24 samples requires approximately 160 minutes to reach a pressure level of 5×10^{-6} torr. The repeated overlays on sample A-24-3 (Fig. 14) show that a total elapsed time of only 122 minutes including the two 30 minute overlay periods is required to reach the pressure 5×10^{-6} torr. Thus, a saving of about 40 minutes pumping time occurs when using repeated overlays as a pump down technique. Time did not permit a more thorough evaluation of the potentiality of overlay as an aid to outgassing.

31. A possible explanation of this behavior is that the dry nitrogen gas acts as a dehydrating agent. This follows from the fact that absorbed water is the most difficult source of outgassing to eliminate in a vacuum system. Small glass vacuum systems are baked out at temperatures in excess of 300°C to

remove the water adsorbed on the glass walls. The balance between the surface density of adsorbed water molecules and the density or number of molecules in the region near the surface is determined by the effective binding energy of the water molecules to the surface. Since these parameters are not precisely known, their effect can only be discussed qualitatively here.

32. The effect of increased temperature is to increase the number of molecules per unit time leaving the surfaces and to decrease the "sticking" probability, that is, the probability that a molecule which collides with the surface will remain on it for a finite period of time instead of immediately rebounding. In the overlay tests conducted in this program the soil simulant was placed in the vacuum chamber at a temperature of about 150° C, and was not heated further afterwards. Consequently, the temperature of the simulant was decreasing for the duration of the tests, which would not tend to remove additional water vapor during successive nitrogen overlays. The action of the nitrogen is probably to reduce the number of times a water molecule collides with the surface of simulant particles as it diffuses out of the simulant, thereby reducing the number of water molecules re-adsorbed within the simulant. This effect would not be fully reproduced by flushing out the oven with dry nitrogen at atmospheric pressure. An alternate explanation would be that the nitrogen act as a purge by drawing water vapor along with it as it flows out of the chamber during evacuation.

Theoretical Evaluation

33. The solution of the one-dimensional diffusion equation is shown for a depth of one meter on Figure 16. The computations were made with time and permeability as parameters. A discussion of the solution is presented in Appendix A. From these curves it can be seen that a high permeability significantly reduces the time required to achieve pressures to the 10^{-5} torr scale at depths in excess of 30-cm (1.0-ft).

PART V: CONCLUSIONS AND RECOMMENDATIONS

34. The following conclusions may be drawn from this study:

- a. Geysering is no problem when pumping properly conditioned simulant.
- b. Simulant conditioning by heating to temperatures above 150° C is effective in reducing pump down time.
- c. Simulant conditioning to temperatures of 325° C provides a significant improvement in pump down performance over 150° C temperature conditioning.
- d. Simulant conditioning to temperatures of 325° C causes a color change but does not appreciably affect the albedo of the simulant.
- e. Simulant conditioning for periods beyond 24 hours did not significantly improve overall system performance for the quantities tested.
- f. Nitrogen overlays at pressures below 10^{-2} torr and for various lengths of time are beneficial in reducing pump down time.
- g. Simulant outgassing is primarily a roughing problem occurring at pressures below 100 microns.
- h. The solution of the diffusion equation illustrates the importance of depositing the simulant at the highest permeability (lowest density) possible.

35. Based upon the results of the tests described and discussed herein, the following recommendations are made:

- a. Simulant conditioning at 325° C is recommended if the observed color change is acceptable.
- b. Nitrogen overlays introduced during the pumping period are recommended as an effective means of reducing pump down times.
- c. The incorporation of boosters to augment the pumping capacity of the mechanical forepumps is recommended.
- d. It is recommended that the simulant be placed at the lowest possible density.

TABLE 7.2.7-1. Compressibility Parameters of Lunar Soil

<u>Parameter</u>	<u>Range</u>	<u>Recommended Typical Value</u>
Compression Index, C_c		0.3
Loose		0.05
Dense	0.01 - 0.11	
Recompression Index, C_r	0.000 - 0.013	0.003
Maximum Past Pressure		Unknown
Coefficient of Lateral Stress, K_0		
Normally consolidated	0.4 - 0.5	0.45
Over-consolidated		Unknown
Recompacted		0.7

SOURCE : DAVID CARRIER III - ROUGH MANUSCRIPT OF A TO BE PUBLISHED BOOK 1989

TABLE 7.2.7-2. Compression Index of Lunar Soils

Mission	Sample Number	Sample Weight (g)	Density Range (g/cm ³)	Stress Range (kPa)	C _c	References
Apollo 12	12002, 119	200	1.67 - 1.82	0.08 - 67.5	0.04 - 0.11	Carrier et al. (1972b, 1973c)
			1.84 - 1.92	0.09 - 31.2	0.012 - 0.062	Carrier et al. (1972b, 1973c)
			1.91 - 2.00	1.9 - 69.9	0.03 - 0.09	Carrier et al. (1972b, 1973c)
Luna 16	---	~10	1.03 - 1.51	0.05 - 98.0	0.3*	Leonovich et al. (1974, 1975); Gromov et al. (1972)
Luna 20	---	~10	0.98 - 1.51	0.05 - 98.0	0.3*	Leonovich et al. (1974, 1975)

*Estimated.

SOURCE: DAVID CARRIER III - ROUGH MANUSCRIPT OF A TO BE PUBLISHED BOOK 1987

**TABLE 7.2.8-1. Estimates of Lunar Soil Cohesion and Friction Angle
(after Mitchell et al., 1972d, 1974)**

<u>Source</u>	<u>Cohesion, c (kPa)</u>	<u>Friction Angle, ϕ (degrees)</u>	<u>References</u>
EARLY INFERRED: REMOTE SENSING	24-240 ≥0.007 ≥0	0 ≥28 ≥25	Halajian (1964) Jaffe (1964) Jaffe (1965)
INFERRED: BOULDER TRACKS	0.35 0.1* 0.5*	33 10-30 21-55 (39 [†])	Nordmeyer (1967) Moore (1970) Hovland and Mitchell (1971)
Apollo 17 - North, East and South massifs	1*	26-50 (37 [‡])	Mitchell et al. (1973a)
SURVEYOR			
I: TV & Landing Data	10	0	Halajian (1966)
TV & Landing Data	0.15-15	55	Jaffe (1967)
TV & Landing Data	0.4 - 0.13	30-40	Christensen et al. (1967)
III: Soil Mechanics		>35	Scott and Roberson (1968a)
Surface Sampler			
TV & Landing Data	0 for	45-60	Christensen et al. (1968a)
	10 for	0	
VI: Vernier Engine	>0.07 for	35	Christensen et al. (1968b)
Attitude Jets	0.05-1.7		Christensen et al. (1968b)
SURVEYOR MODEL			
III & VII: Soil Mechanics			
Surface Sampler	0.35-0.70	35-37	Scott and Roberson (1969)
APOLLO 11			
LM Landing, Boot- prints, Crater Slope	Consistent with Surveyor Model		Costes et al. (1969)
Stability			
Core Tube, Flag Pole, SWC Shaft Penetration	0.75-2.1	37-45	Costes et al. (1971)
APOLLO 12			
LM Landing, Boot- prints, Crater Slope	Consistent with Surveyor Model		Scott et al. (1970)
Stability			

SOURCE: DAVID CARRIER III - ROUGH MANUSCRIPT OF A TO BE PUBLISHED
BOOK 1987

Core Tube, SWC Shaft Penetration	0.56-0.75	38-44	Costes et al. (1971)
LUNOKHOD I Vane Shear	3.9-4.9	N/A	<i>Join up</i> Leonovich et al. (1971, 1972) Mitchell et al. (1972d);
- Lowest	0.26-1.1	50-25	
- Highest	1.2-4.8	50-25	
- Mode	0.64-2.6	50-25	
Cone Penetrometer			Mitchell et al. (1972d);
- Crater Wall (inner)	0.17-1.0	45-25	
- Crater Slope (outer)	0.52-2.7	45-25	
- Horizontal Ground	0.34-1.8	45-25	
APOLLO 14 Soil Mechanics Trench	<0.03-0.1	35-45	Mitchell et al. (1971)
Apollo Simple Penetrometer	Equal to or greater than Surveyor Model	37-47	Mitchell et al. (1971)
MET Tracks			Mitchell et al. (1971)
APOLLO 15 SRP Data and Simulation Studies		47.5-51.5	Mitchell et al. (1972a)
SRP Data and Soil Mechanics Trench	1.0	50	Mitchell et al. (1972a)
APOLLO 16 SRP: Station 4 (10-20 cm depth)	0.6	46.5	Mitchell et al. (1972b)
SRP: Station 10	0.37	49.5	Mitchell et al. (1972b)
SRP: Station 10	0.25-0.60	50-47	Mitchell et al. (1972b)
Drill Core Open Hole	1.3	46.5	Mitchell et al. (1972b)
APOLLO 17 Drill Core Open Hole (Neutron Flux Probe)	1.1-1.8	50-30	Mitchell et al. (1973a)
LRV	0.17	35	Mitchell et al. (1973a)
	0.1-1.0	APOLLO MODEL 30-50	Mitchell et al. (1972d, 1974)
LUNOKHOD I & II (ave.)	0.4 ^S	40 ^S	Leonovich et al. (1974, 1975)
RETURNED LUNAR SAMPLES Apollo 11: Penetrometer	0.25-0.85	42-38	Costes et al. (1969, 1970a, b); Costes and

SOURCE: DAVID CARRIER III - ROUGH MANUSCRIPT OF A TO BE PUBLISHED BOOK 1987

ORIGINAL PAGE IS
OF POOR QUALITY

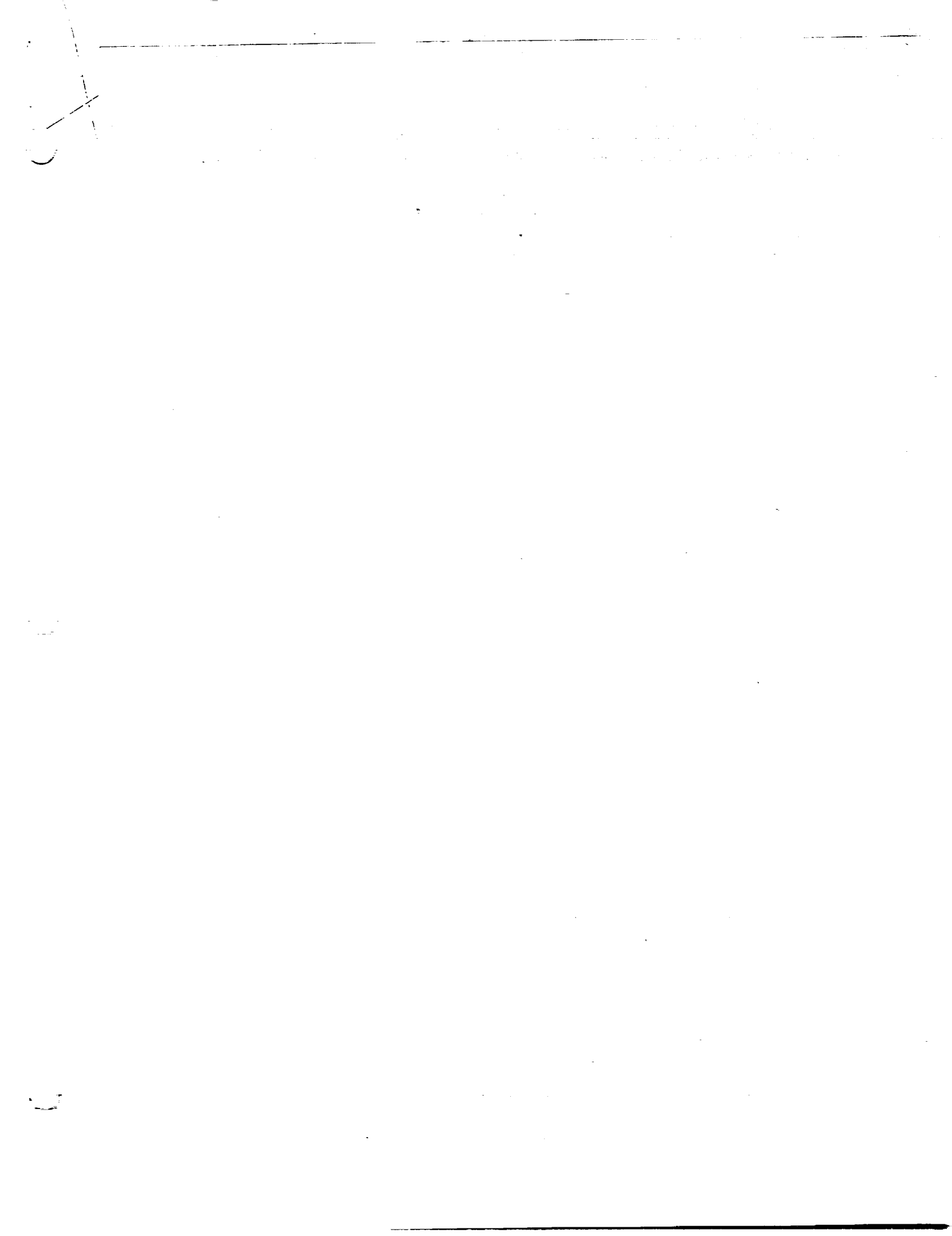

END