

NTG 5-1111

600 1111
WANT
IN 64-1K
P-8



COLLEGE PARK CAMPUS

DEVELOPMENT OF EYE-SAFE LIDAR FOR AEROSOL MEASUREMENTS

by

Upendra N. Singh and Thomas D. Wilkerson

Atmospheric Lidar Observatory

Institute for Physical Science and Technology

University of Maryland, College Park, Maryland 20742-2431

BN-1114

(NASA-CR-186905) DEVELOPMENT OF EYE-SAFE
LIDAR FOR AEROSOL MEASUREMENTS Final Report,
1968-1990 (Maryland Univ.) 8 6 CSCL 060

N90-26505

Unclas

63/54 0296785

August 1990

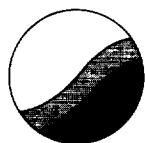

INSTITUTE FOR PHYSICAL SCIENCE
AND TECHNOLOGY

DEVELOPMENT OF EYE-SAFE LIDAR FOR AEROSOL MEASUREMENTS ¹

by

Upendra N. Singh and Thomas D. Wilkerson

Atmospheric Lidar Observatory

Institute for Physical Science and Technology

University of Maryland, College Park, Maryland 20742-2431

ABSTRACT

Research is summarized on the development of an eye-safe Raman conversion system to carry out lidar measurements of aerosol and clouds from an airborne platform. Radiation is produced at the first Stokes wavelength of $1.54 \mu\text{m}$ in the eye-safe infrared, when methane is used as the Raman-active medium, the pump source being a Nd:YAG laser at $1.064 \mu\text{m}$. Results are presented for an experimental study of the dependence of the $1.54 \mu\text{m}$ first Stokes radiation on the focusing geometry, methane gas pressure, and pump energy. The specific new technique developed for optimizing the first Stokes generation involves retroreflecting the backward-generated first Stokes light back into the Raman cell as a seed Stokes beam which is then amplified in the temporal tail of the pump beam. Almost 20% conversion to $1.54 \mu\text{m}$ is obtained.

Complete, assembled hardware for the Raman conversion system was delivered to the Goddard Space Flight Center for a successful GLOBE flight (1989) to measure aerosol backscatter around the Pacific basin.

¹ A final report on research carried out under NAG-5-1114, sponsored by NASA-Goddard Space Flight Center, for the period 1988-1989.

DEVELOPMENT OF EYE-SAFE LIDAR FOR AEROSOL MEASUREMENTS

In response to the need for improved aerosol and cloud lidar capabilities in the near infrared ($\lambda < 4 \mu\text{m}$), we have carried out a development program for the efficient generation of "Raman shifted" $1.54 \mu\text{m}$ radiation based on commercially available Nd:YAG lasers. Our innovative method, in its first version, has been successfully applied in NASA's 1989 airborne survey of Pacific aerosols as part of the GLOBE project. This report describes the developed system, its performance and the new technique used for enhancing the system performance at $1.54 \mu\text{m}$.

While lidar measurements involving two or more wavelengths have been made for some years, both in the longer wave region of the CO_2 laser ($\sim 10.6 \mu\text{m}$) and the shorter wavelengths of Nd:YAG laser system ($1.06 \mu\text{m}$, 532 nm SHG), there are several reasons why the near IR "window regions" - particularly around $1.5\text{-}1.6 \mu\text{m}$ - are important for improved lidar operations:

- (1) Mie backscatter cross sections at $1.54 \mu\text{m}$ are generally much higher than at the CO_2 laser wavelengths, which provides an intrinsically higher sensitivity to aerosol. The infrared window regions may, in the long run, prove to be better for lidar applications than the $10 \mu\text{m}$ window, because of more consistent sensitivity to particulates in clean portions of the atmosphere.
- (2) Multiwavelength Nd-based lidars for distinguishing between Rayleigh and Mie backscatter require a greater λ -range than is available with $\lambda_{\text{max}} = 1.06 \mu\text{m}$.
- (3) Distinction between ice and liquid water particulates in high clouds are predicted to be possible, using lidar backscatter at $1.54 \mu\text{m}$.
- (4) Wavelengths $\lambda > 1.4 \mu\text{m}$ are, practically speaking, eye-safe.
- (5) Improved detectors (InGaAs) are now available for the near IR, out to $1.7\text{-}1.8 \mu\text{m}$.
- (6) Detection of a lidar return signal at $1.54 \mu\text{m}$ is much easier than at $10.6 \mu\text{m}$ because of detector and amplifier properties and the need for cryogenic cooling of long wave detectors.

Stimulated Raman scattering (SRS) has been widely used to produce light at wavelengths where conventional laser sources are not available. The system developed is based upon a Nd:YAG laser at 1.06 μm which is then Raman-shifted in methane to produce light at the first Stokes wavelength of 1.54 μm . Because of the drastic fall-off in the single-pass SRS conversion with increasing wavelength and limited pump energy available from the laser to be used in the GLOBE experiment, we investigated and found an optimum "seeding" technique for efficient output. *Almost 20% conversion to 1.54 μm was obtained* by reinjecting the backward wave Raman radiation to "boost" the net conversion to the first Stokes output, compared to only a few percent that would have been obtained with the familiar, one-pass system. The schematic of the experimental setup is shown in Fig. 1. Table I provides a list identifying different optical components shown in Fig. 1, and being delivered to NASA/GSFC for integration in a three-wavelength lidar system. A published account of this work is given in Appendix A, so that not much repetition is needed here. The success of this method has made it possible for NASA to add 1.54 μm observations to the GLOBE flight measurements in 1989, using a Raman conversion system built at University of Maryland.

A summary of the major tasks performed at University of Maryland under NASA/GSFC grant NAG-5-1114 is listed below:

1. Design and fabrication of two high pressure, stainless steel "Raman shifter" gas cells of 1 meter length, as per safety specifications from NASA/Ames Research Center. Pressure and leak testing at 1900 psi of nitrogen. Approval granted for flight on NASA's DC-8 aircraft, as a part of the NASA/GSFC aerosol experiment for GLOBE project.
2. Experimental study of the dependence of the of the 1.54 μm first Stokes radiation on the focusing geometry, methane gas pressure, and pump energy. Optimization of first Stokes radiation using "backward wave seeding". Beam divergence measurements in the laboratory.
3. Delivery of Raman conversion system to NASA/GSFC.
4. Assistance in integrating the Raman conversion system into the lidar system at NASA/GSFC.
5. Demonstration of optimum operation of Raman conversion system using pump laser at NASA/GSFC.
6. Training of NASA/GSFC technical personnel for operating the Raman conversion system.

Details of the research results are given in the journal article and presentation abstracts included as Appendices A-C to this report. References for these documents are given below. This completes the final report on research and development carried out under NAG-5-1114.

APPENDICES

- A. Z. Chu, U. N. Singh, and T. D. Wilkerson, "A Self-Seeded SRS System for the Generation of 1.54 μm Eye-Safe Radiation", *Optics Communications*, 75, 173-178 (1990).
- B. U. N. Singh, Z. Chu, and T. D. Wilkerson, "Generation of Eye-Safe Radiation for Aerosol Lidar Operation", *IEEE Digest of International Geoscience and Remote Sensing Symposium (IGARSS '90)*, College Park, MD, May 20-24, 1990.
- C. U. N. Singh, Z. Chu, and T. D. Wilkerson, "Efficient Near-IR Light Source for Eye-Safe Lidar Applications", *Proc. Optical Remote Sensing of the Atmosphere (1990)*, OSA Topical Mtg., Incline Village, NV, p 247-250, February 12-15, 1990.

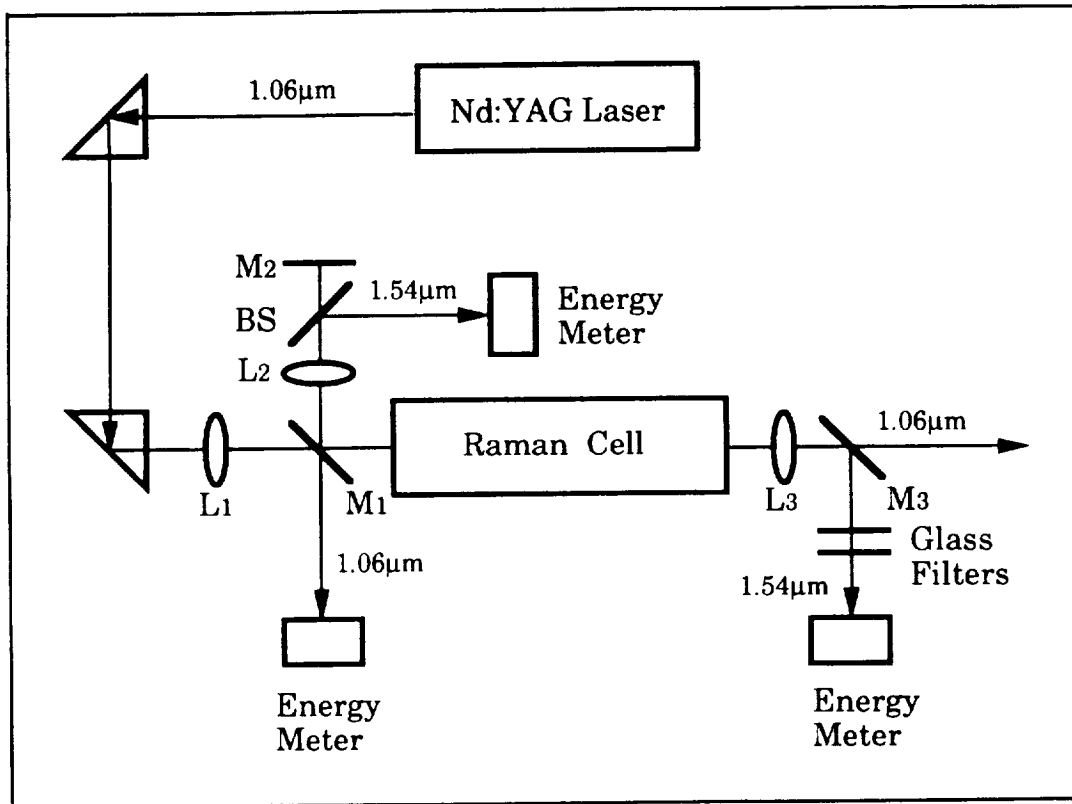

Figure 1. Plan view of experimental setup for Raman conversion system.

TABLE I

LIST IDENTIFYING DIFFERENT OPTICAL COMPONENTS SHOWN IN FIG. 1,
AND BEING DELIVERED TO NASA/GSFC

-
1. L_1 -- Lens (focal length = +100 cm)
 2. L_2 -- Lens (focal length = +75 cm)
 3. L_3 -- Lens (focal length = +75 cm)
 4. M_1 -- Dichroic mirror (T_{max} 1.06 /R_{max} 1.54 μm , @ $\theta = 45$ deg, 2" diam)
 5. M_2 -- Dichroic mirror (T_{max} 1.06 /R_{max} 1.54 μm , @ $\theta = 0$ deg, 2" diam)
 6. M_3 -- Dichroic mirror (T_{max} 1.06 /R_{max} 1.54 μm , @ $\theta = 45$ deg, 2" diam)
 7. BS -- Beam splitter (4% reflection at 1.54 μm , AR coated at 1.06 μm)
 8. Raman cell windows (one side AR coated at 1.06 and 1.54 μm , 1.5" diam)
 9. Color glass filters at 1.06 and 1.54 μm
 10. Two Raman cells (1 meter in length, 2" diam)
-

APPENDIX A