

603624  
P.33

**NASA  
Technical  
Paper  
2951**

November 1989

**Evaluation of Energy  
Absorption of New  
Concepts of Aircraft  
Composite Subfloor  
Intersections**

Lisa E. Jones  
and Huey D. Carden

1990-17507-1 EVALUATION OF ENERGY  
ABSORPTION OF NEW CONCEPTS OF AIRCRAFT  
COMPOSITE SUBFLOOR INTERSECTIONS (PAPER)



**NASA  
Technical  
Paper  
2951**

1989

Evaluation of Energy  
Absorption of New  
Concepts of Aircraft  
Composite Subfloor  
Intersections

Lisa E. Jones  
*PRC Kentron, Inc.*  
*Aerospace Technologies Division*  
*Hampton, Virginia*

Huey D. Carden  
*Langley Research Center*  
*Hampton, Virginia*



National Aeronautics and  
Space Administration  
Office of Management  
Scientific and Technical  
Information Division

## Summary

With composite materials being used more frequently in aircraft structures, research is being performed to determine better energy-absorbing designs for composite aircraft components. The NASA Langley Research Center obtained composite intersections that implemented designs similar to those that performed well in metal aircraft. Forty-one composite specimens of aircraft subfloor intersections (cruciforms) were tested to determine the effects of geometry and material on the energy-absorbing behavior, failure characteristics, and postcrush structural integrity of the specimens. The cruciforms were constructed of 12-ply ( $[\pm 45]_6$ ) laminates of either Kevlar 49/934 or AS-4/934 graphite epoxy in heights of 4, 8, and 12 in. The geometry of the specimens varied in the designs of the intersection attachment angle. Four different geometries were tested.

Based upon specific energy absorption, peak loads, sustained crushing loads, and postcrush structural integrity, the best performance was exhibited by the Kevlar tapered specimens without cutouts. The graphite-epoxy specimens, which did not have the plasticlike behavior of the Kevlar specimens, showed brittle, catastrophic behavior and maintained little postcrush structural integrity.

## Introduction

Interest by the U.S. Army in utilizing composites in aircraft has led to a joint research effort between the U.S. Army Aerostructures Directorate and the NASA Langley Research Center to develop efficient, energy-absorbing composite helicopter structures. The crashworthiness of an aircraft is based upon its ability to protect the occupants from serious and/or fatal injury in a crash situation. In most aircraft, there are structural components such as landing gears, seats, and subfloors that can absorb energy. If the overall energy absorption is optimized by the aircraft designer, the loads transmitted to the occupants can be significantly reduced in the event of a crash. Thus, one area of aircraft structures that should be of concern to the designer is the intersections of longitudinal subfloor beams and lateral bulkheads which form efficient load paths or "hard points." These hard points transfer high loads to the seat/occupant and often prevent desirable energy-absorbing failure modes from occurring during a crash. To develop better energy-absorbing structures, new concepts for subfloor structures are being designed and tested.

During the General Aviation Crash Dynamics Program at the NASA Langley Research Center, efforts in the area of subfloor designs for crash

dynamics were directed toward metal aircraft (refs. 1 to 3). The application of composite materials to aircraft structures offers potentially significant weight-saving, cost reductions, and improved corrosion resistance compared to metal structures. However, because of the different material properties of composites, the existing metal-aircraft crash-test data can be used as a guide but cannot necessarily be directly applied to composite structures. More recently, considerable work has been focused on determining the energy-absorbing properties of composite materials. (For example, see refs. 4 to 6.) Since composites typically are brittle and do not necessarily exhibit plasticity or high elongation (or compression) prior to failure, changes are required in the geometry (designs) in many composite aircraft structural elements. The changes are needed to maintain structural integrity around the occupants in the event of a crash and to provide efficient energy-absorbing mechanisms. Therefore, new concepts of potential subfloor structures need to be tested to verify the energy-absorbing behavior and properties of the design. The specific energy absorption, peak loads, sustained crushing loads, and postcrush integrity are characteristics that should be reviewed to determine if the structure will approach the desired behavior in a crash situation.

The purpose of this paper is to present experimental results from the evaluation of the energy-absorbing characteristics of composite subfloor intersections. A comparison of the different designs is based upon the specific energy absorbed, peak loads, sustained crushing loads, and postcrush structural integrity. The performance of the specimens should provide a baseline for further development and improvement of composite intersection designs. The eventual goal is to develop more efficient structural subfloor concepts for use in composite aircraft structures.

## Test Specimens

Geometries of the test specimens are shown in figures 1 and 2. The specimens (cruciforms) represent the intersection of an aircraft floor structure where longitudinal beams and lateral bulkheads are connected, generally through angle-type attachments. These cruciforms are the composite laminate versions of the sandwich-concept design that was tested and reported in reference 6. The four intersection attachment-angle concepts applied in the present study are given as follows:

1. Tapered without cutouts (TWOCO)
2. Tapered with cutouts (TWCO)(Kevlar only)

3. Straight without cutouts (SWOCO)
4. Straight with cutouts (SWCO)(Kevlar only)

The number of cutouts in the intersections varied for the different height specimens. Four-in. specimens had 2 and/or 3 cutouts, 8-in. specimens had 4 and/or 6 cutouts, and 12-in. specimens had 5 and/or 11 cutouts.

Various concepts of the attachments were used that could provide the necessary static loads strength and flight loads strength and that could potentially exhibit good energy-absorbing characteristics in the event of a crash. The initial intent of the cutouts was to minimize the high loads transmitted by the joints and to allow desirable failure (collapse) modes to occur. Thus, the high-potential energy-absorption capability of the composite material may be more efficiently utilized in the subfloor structure.

The cruciform specimens were constructed of 12-ply ( $[\pm 45]_6$ ) laminates of either Kevlar<sup>1</sup> 49/934 or AS-4/934 graphite epoxy in heights of 4, 8, or 12 in. Rivets were used to secure the attachment angles during the bonding of the attachment angles to the webs. The rivets did not provide additional strength to the joints. Table I lists the different specimens of which at least three replicates of each type were fabricated and tested. For test purposes, each end was affixed to a 6-in-square by 1/4-in-thick aluminum plate. At the location where the specimen attached to the bottom plate, a 1/4-in-radius crush initiator was used as illustrated in figure 2. A crush initiator is a special structural design feature that may provide several desirable structural behavior characteristics such as (1) determining the location of initial crushing, (2) determining the initial crushing mode, and (3) reducing the initial peak crushing load. (See ref. 4.) To allow specific energy absorption to be determined, the specimens were weighed and pertinent dimensions were recorded prior to adding the aluminum end plates.

## Test Apparatus and Procedure

Quasi-static testing of the cruciform specimens was performed using a 120 000-lbf testing machine shown in figure 3. The ends of the cruciforms initially were prevented from twisting by using a constraint plate and pins. Specimens were crushed to 25 percent of their original height at a head travel rate of 2 in/min. Load and deflection data were sampled at 400 samples per minute. Data were recorded on a personal computer data acquisition system with 12-bit data resolution and were reduced using a spreadsheet computer program. Calculations of the total

energy absorbed, sustained crushing load, and specific energy absorbed (energy absorbed per pound of material per inch of deflection) were made to provide similar terms for a comparison of performance among the various intersection concepts.

## Definitions and Evaluation Criteria

Quasi-static crush results from the performance of the four different composite specimens of subfloor intersections (cruciforms) are evaluated and discussed using the following terms (refs. 6 and 7):

1. Peak load — the loads associated with prebuckling
2. Sustained crushing load — the mean of the load history after crush initiation
3. Stroke — the maximum displacement of the load
4. Energy absorbed — the energy dissipated by a system and represented by the area under the load-deflection curve
5. Specific energy — the energy absorbed per unit weight per unit crush
6. Postcrush integrity — the residual structural capability of the structure

Ideally, the peak loads that occur during the crushing of the specimen should not exceed the sustained crushing load by more than approximately 25 percent. The ratio of the stroke to the original height of the specimen should be high (75 percent or greater) to reduce weight penalties. Also, weight penalties can be prevented by keeping the specific energy as high as possible. Keeping the specific energy high allows maximum energy absorption with the least amount of material. Finally, good postcrush structural integrity should be maintained.

## Results and Discussion

Results of quasi-static crushing tests performed with the four different composite specimens of subfloor intersections constructed of either Kevlar or graphite epoxy are presented in figures 4 through 16 and table II. Results include load-deflection plots, tabulated peak loads, specific energy absorption, sustained crushing loads, and an assessment of the structural integrity of the specimens after crushing.

### Performance of Cruciform Specimens

**Tapered without cutouts (TWOCO).** A Kevlar 12-in. TWOCO specimen is pictured in figure 4, and typical load-deflection data are presented in figure 5. As shown, good postcrush structural integrity and accordionlike buckling are typical characteristics of

<sup>1</sup> Trademark of E. I. du Pont de Nemours & Co., Inc.

the Kevlar TWOCO specimens. However, delamination and debonding are apparent in the photograph of figure 4. In general, the Kevlar specimens exhibited initial peak loads that were less than 1.3 times the sustained crushing load. The 4-, 8-, and 12-in-high specimens (identified as K0400T, K0800T, and K1200T, respectively, where K denotes Kevlar, 04 denotes height series, 00 denotes number of cutouts, and T denotes tapered) showed gradually increasing energy absorption with crushing corresponding to the increase in the load-carrying capability associated with the widening of the tapered angle attachment of this concept. Various peak loads noted in figure 5 are due to the accordionlike local buckling of the intersection material, and these peak loads were less than twice the sustained crushing loads.

A crushed graphite-epoxy 4-in. TWOCO specimen is pictured in figure 6 and typical data for the TWOCO cruciforms (identified as C0400T, C0800T, and C1200T) are presented in figure 7. As shown in figure 6, all structural integrity and load-carrying capability was lost during the loading of the specimen. The initial peak loads were considerably higher than the sustained crushing load (some peaks were five times as high), and catastrophic failure, especially in the taller specimens, occurred almost immediately after the initial peak load.

#### ***Tapered with cutouts (TWCO) (Kevlar only).***

Crushed Kevlar TWCO specimens are pictured in figure 8. Typical load-deflection data for the cruciforms (identified as K0402T, K0403T, K0804T, K0806T, K1205T, and K1211T) are given in figure 9. The 8-in. TWCO specimen pictured in figure 8(a) maintained better structural integrity than the 12-in. specimen pictured in figure 8(b). In the region around the cutouts, both specimens showed a tendency for delamination and debonding of both the angle attachment and the webs. The TWCO specimens had initial peak loads of about 1.4 times the sustained crushing load. The loss of load-carrying capability by the K1211T specimens is apparent in the load-deflection data presented in figure 9(c). Also, the 12-in. specimen shows signs of global buckling. From column buckling considerations, the critical buckling load is directly proportional to the bending stiffness of the section and inversely proportional to the length squared. Thus, the buckling load for the 12-in. specimens would be the lowest of the 4-, 8-, or 12-in. heights. Additionally, with the delamination and debonding of the angles and webs, a substantial loss of bending stiffness occurs. It appears that the loss reduced the critical column or global

buckling load below the local failure load, thus giving rise to the overall global failure mode noted and consequently the lower energy absorption.

***Straight without cutouts (SWOCO).*** A crushed Kevlar 12-in. SWOCO specimen is pictured in figure 10 and typical load-deflection data for the specimens (identified as K0400S, K0800S, and K1200S) are presented in figure 11. Accordionlike local buckling of the SWOCO specimens is very much like that of the Kevlar TWOCO specimens. Although delamination and debonding may be noted, the Kevlar SWOCO specimens maintained good postcrush integrity. The initial peak loads are approximately 1.7 times the sustained crushing load. The 8- and 12-in. specimens have various peak loads throughout the data that resulted from the accordionlike local buckling of the specimen.

A graphite-epoxy 8-in. specimen of the SWOCO configuration is presented in figure 12, and typical load-deflection data for the specimens (identified as C0400S and C0800S) are presented in figure 13. Unlike the graphite-epoxy TWOCO cruciforms, the 4- and 8-in-high specimens did not fail catastrophically. A sustained crushing load was maintained for the crush duration and some structural integrity existed. Extremely high initial peak loads of more than twice the sustained crushing load were recorded. Inconsistent loads were observed with the 12-in. specimens (C1200S), and a loss of data occurred when unexpectedly high peak loads exceeded calibration levels.

#### ***Straight with cutouts (SWCO) (Kevlar only).***

A Kevlar 12-in. SWCO specimen is pictured in figure 14, and typical crush data for the straight cruciform specimens with cutouts (identified as K0402S, K0403S, K0804S, K0806S, K1205S, and K1211S) are presented in figure 15. As noted with the Kevlar TWCO specimens, the Kevlar SWCO specimens had a tendency to delaminate and debond in the area of the cutouts and attachment angle. A higher degree of delamination and debonding in the 8- and 12-in. specimens with high cutout counts resulted in a greater loss of postcrush structural integrity. The load-deflection data of figure 15 indicate that high initial peak loads of more than twice the sustained loads occurred with these specimens. After the initial peak loads, most of the load-carrying capability of the specimens was very low as shown in the data plots of figures 15(b) and 15(c).

#### **Comparison of Concept Performance**

The data presented in table II are presented in figure 16 as bar graphs to make trends more

apparent and to facilitate comparisons between the Kevlar and/or the graphite-epoxy specimens where applicable. The graphs present sustained crushing load, the ratio of peak load to sustained load, peak load, and specific energy absorption as a function of specimen type.

Data for the 4-in-high Kevlar and graphite-epoxy straight and tapered specimens with and without cutouts are presented in figure 16(a). For the Kevlar specimens, sustained crushing load increased with the number of cutouts for the tapered attachment-angle concept, whereas the sustained crushing load decreased with the number of cutouts in the straight attachment-angle concept. Peak load ranged from about 2300 to 3300 lbf. The ratio of the peak load to the sustained load was 1.7 or more (with the exception of the tapered specimen with three cutouts), whereas the ideal value is a ratio close to 1. Comparisons indicate that the tapered specimens with cutouts had higher specific energy absorption than the straight specimens.

For the graphite-epoxy specimens, sustained crushing load, peak load, and specific energy absorption were higher than those for the Kevlar specimens. The ratio of peak load to sustained load was comparable to that of the Kevlar specimens. Additionally, the performance values of the graphite-epoxy tapered concept were lower than those of the graphite-epoxy straight concept. Specific energy absorption was higher than for the Kevlar specimens; however, extremely high peak loads biased the energy absorption and, as noted earlier, structural integrity was not maintained.

A comparison of the data for the 8-in-high Kevlar and graphite-epoxy straight and tapered specimens with and without cutouts is presented in figure 16(b). For both the tapered and the straight Kevlar cruciform specimens, sustained crushing load decreased with increasing number of cutouts. The tapered and straight graphite-epoxy specimens had sustained crushing loads that were comparable to those of the tapered and straight Kevlar specimens without cutouts. Generally, the peak loads decreased with the number of cutouts, and the graphite-epoxy peak loads were higher than the peak loads of either type of Kevlar specimen. The trend of the ratio of peak load to sustained load was generally between 1.4 and 2. The exceptions were the Kevlar straight specimens with four and six cutouts. Specific energy decreased with increasing number of cutouts for both the straight and the tapered Kevlar specimens. The graphite-epoxy specimens had specific energy values that were comparable to those of the straight and tapered Kevlar specimens without cutouts.

A comparison of data for the 12-in-high specimen is presented in figure 16(c). As may be noted, the sustained load, specific energy absorption, and peak load for the tapered specimens with and without cutouts decreased with the number of cutouts. The trend of the ratio of peak load to sustained load was to increase with the number of cutouts for both the tapered and the straight concepts. The ratios of peak load to sustained load were, however, higher than the desired value of 1; the graphite-epoxy tapered specimen and the Kevlar straight specimen with 11 cutouts had a ratio of approximately 4. The peak load for the Kevlar straight specimens with and without cutouts was comparable. The graphite-epoxy tapered specimen (the only available specimen) had the highest peak load of all the 12-in. specimens tested. Specific energy absorption was higher for the graphite-epoxy specimens; again, however, the peak load, ratio of peak load to sustained load, and structural integrity were indicators that these concepts were not ideal for the graphite-epoxy material.

## Conclusions

Experiments were conducted to determine the energy-absorbing characteristics and performance of Kevlar and graphite-epoxy aircraft subfloor intersections. Various concepts for the attachment of laminated longitudinal floor beams and lateral bulkheads were incorporated into cruciform specimens for static testing. The performance of the concepts was evaluated based on peak loads, sustained crushing loads, specific energy absorption, ratio of peak loads to sustained loads, and a subjective evaluation of structural integrity following the crushing tests. Results from the study support the following conclusions:

1. Local failure modes with multiple buckling are necessary to achieve high-energy absorption efficiency for the intersection concepts.
2. Structural integrity was maintained with the plasticlike behavior of the Kevlar material. Structural integrity was not achieved with the brittle graphite-epoxy system.
3. A tapered attachment-angle concept applied to subfloor intersections constructed in a laminate provided the best performance for peak loads, sustained crushing, specific energy absorption, and structural integrity.
4. Attachment concepts with cutouts in the webs of the intersections tended to reduce the various performance parameters more than the concepts without cutouts.
5. The cutouts led to undesirable delaminations in both the angles and the webs of the Kevlar

specimens, thus reducing the overall efficiency of the concepts.

NASA Langley Research Center  
Hampton, VA 23665-5225  
September 12, 1989

## References

1. Carden, Huey D.; and Hayduk, Robert J.: *Aircraft Subfloor Response to Crash Loadings*. SAE Tech. Paper Ser. 810614, Apr. 1981.
2. Cronkhite, J. D.; and Berry, V. L.: *Crashworthy Airframe Design Concepts—Fabrication and Testing*. NASA CR-3603, 1982.
3. Carden, Huey D.: *Full-Scale Crash-Test Evaluation of Two Load-Limiting Subfloors for General Aviation Airframes*. NASA TP-2380, 1984.
4. Farley, Gary L.: *Energy Absorption of Composite Materials*. NASA TM-84638, AVRADCOM TR-83-B-2, 1983.
5. Bannerman, D. C.; and Kindervater, C. M.: *Crashworthiness Investigation of Composite Aircraft Subfloor Beam Sections*. IB 435—84/3 (1984), Deutsche Forschungs-und Versuchsanstalt für Luft-und Raumfahrt, Feb. 1984.
6. Cronkhite, J. D.; Chung, Y. T.; and Bark, L. W.: *Crashworthy Composite Structures*. USAAVSCOM TR-87-D-10, U.S. Army, Dec. 1987. (Available from DTIC as AD B121 522.)
7. Coppa, Anthony P.: *New Ways To Soften Shock*. *Mach. Design*, vol. 40, no. 8, Mar. 28, 1968, pp. 130-140.

Table I. Cruciform Variables

Cruciform	Serial number	Composite prepreg (a)	Cruciform dimensions			Intersection concepts	
			Height, in.	Length, in.	Width, in.	Type	Number of cutouts
K0400T	1, 2, 3	1	4	6	6	Tapered	0
C0400T	1, 2, 3	2	4	6	6	Tapered	0
K0800T	1, 2, 3	1	8	6	6	Tapered	0
C0800T	1, 2, 3	2	8	6	6	Tapered	0
K1200T	1, 2, 3	1	12	6	6	Tapered	0
C1200T	1, 2, 3	2	12	6	6	Tapered	0
K0400S	1, 2, 3	1	4	6	6	Straight	0
C0400S	1, 2, 3	2	4	6	6	Straight	0
K0800S	1, 2, 3	1	8	6	6	Straight	0
C0800S	1, 2, 3	2	8	6	6	Straight	0
K1200S	1, 2, 3, 4, 5, 6	1	12	6	6	Straight	0
C1200S	1, 2, 3	2	12	6	6	Straight	0
K0402S	1, 2, 3	1	4	6	6	Straight	2
K0403S	1, 2, 3	1	4	6	6	Straight	3
K0804S	1, 2, 3	1	8	6	6	Straight	4
K0806S	1, 2, 3	1	8	6	6	Straight	6
K1205S	1, 2, 3	1	12	6	6	Straight	5
K1211S	1, 2, 3	1	12	6	6	Straight	11
K0402T	1, 2, 3	1	4	6	6	Tapered	2
K0403T	1, 2, 3	1	4	6	6	Tapered	3
K0804T	1, 2, 3	1	8	6	6	Tapered	4
K0806T	1, 2, 3	1	8	6	6	Tapered	6
K1205T	1, 2, 3	1	12	6	6	Tapered	5
K1211T	1, 2, 3	1	12	6	6	Tapered	11

<sup>a</sup>1: Kevlar; 2: graphite epoxy.



Table II. Cruciform Performance

Specimen	Cruciform	Maximum peak loads, lbf	Sustained crushing load, lbf	Specific energy absorption per inch of crush, (lbf-in/lb)/in.	Structural integrity
Tapered without cutouts (TWOCO)	K0400T	3000	1730	11664	Good
	C0400T	4500	3000	16794	Poor
	K0800T	4000	2600	7264	Good
	C0800T	4800	2900	8073	Poor
	<sup>a</sup> K1200T	3360	2250	4112	Good
	C1200T	3700	780	1960	Poor
Tapered with cutouts (TWCO)	K0402T	3300	1940	13775	Good
	K0403T	2760	2100	11779	Good
	K0804T	2550	1690	5835	Good
	C0806T	2650	1370	4172	Fair
	K1205T	2400	1200	2474	Fair
	K1211T	2130	830	1655	Poor
Straight without cutouts (SWOCO)	K0400S	2980	1660	9766	Good
	C0400S	6140	3480	18583	Fair
	K0800S	3590	2550	6356	Good
	C0800S	5470	2700	6763	Fair
	<sup>a</sup> K1200S	3560	2130	3467	Good
	C1200S	(b)	(b)	(b)	(b)
Straight with cutouts (SWCO)	K0402S	2460	1360	8135	Good
	K0403S	2260	1090	6491	Fair
	K0804S	4170	1740	4555	Fair
	K0806S	2770	900	4058	Poor
	K1205S	2940	1190	1999	Fair
	K1211S	3580	870	1527	Poor

<sup>a</sup>These specimens were crushed only 6 in.

<sup>b</sup>Inconsistent loads caused loss of data.

ORIGINAL PAGE  
BLACK AND WHITE PHOTOGRAPH

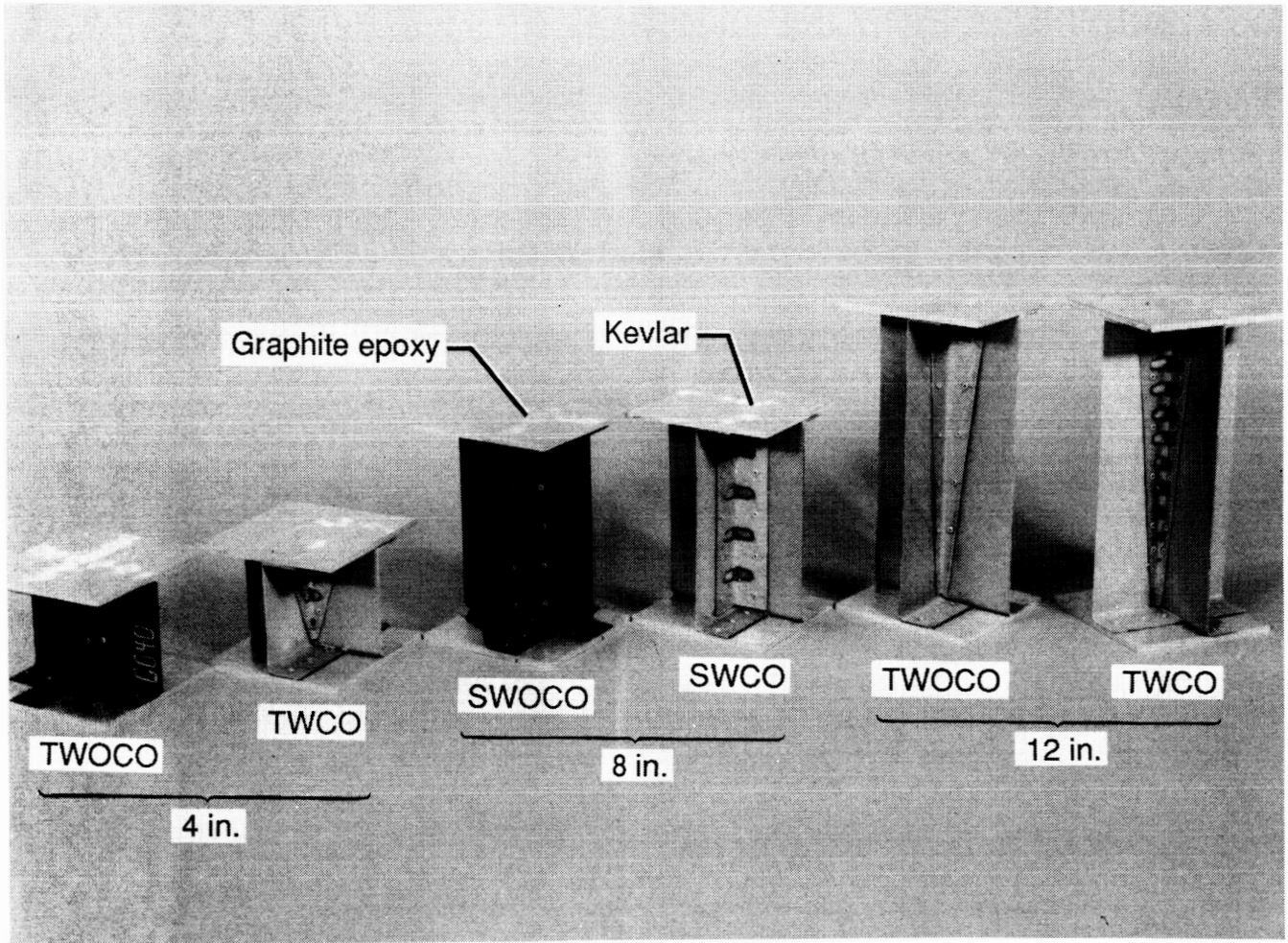

L-87-6353

Figure 1. Concepts of composite aircraft subfloor intersections for energy absorption. Tapered without cutouts (TWOCO); tapered with cutouts (TWCO); straight without cutouts (SWOCO); straight with cutouts (SWCO).

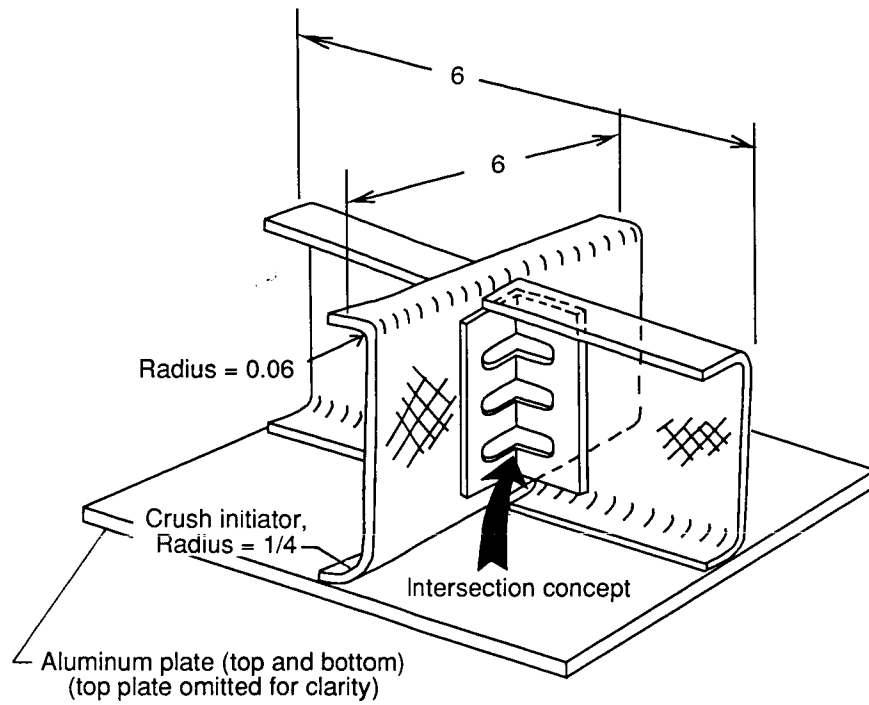

(a) Straight intersection with cutouts.

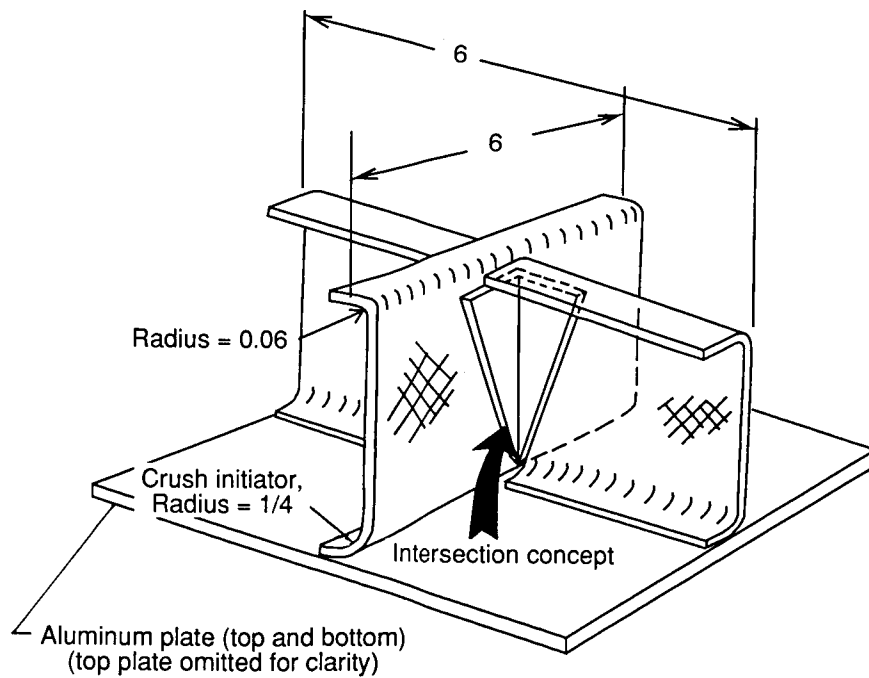

(b) Tapered intersection without cutouts.

Figure 2. Details of the intersection concepts. All linear dimensions are given in inches.

ORIGINAL PAGE  
BLACK AND WHITE PHOTOGRAPH

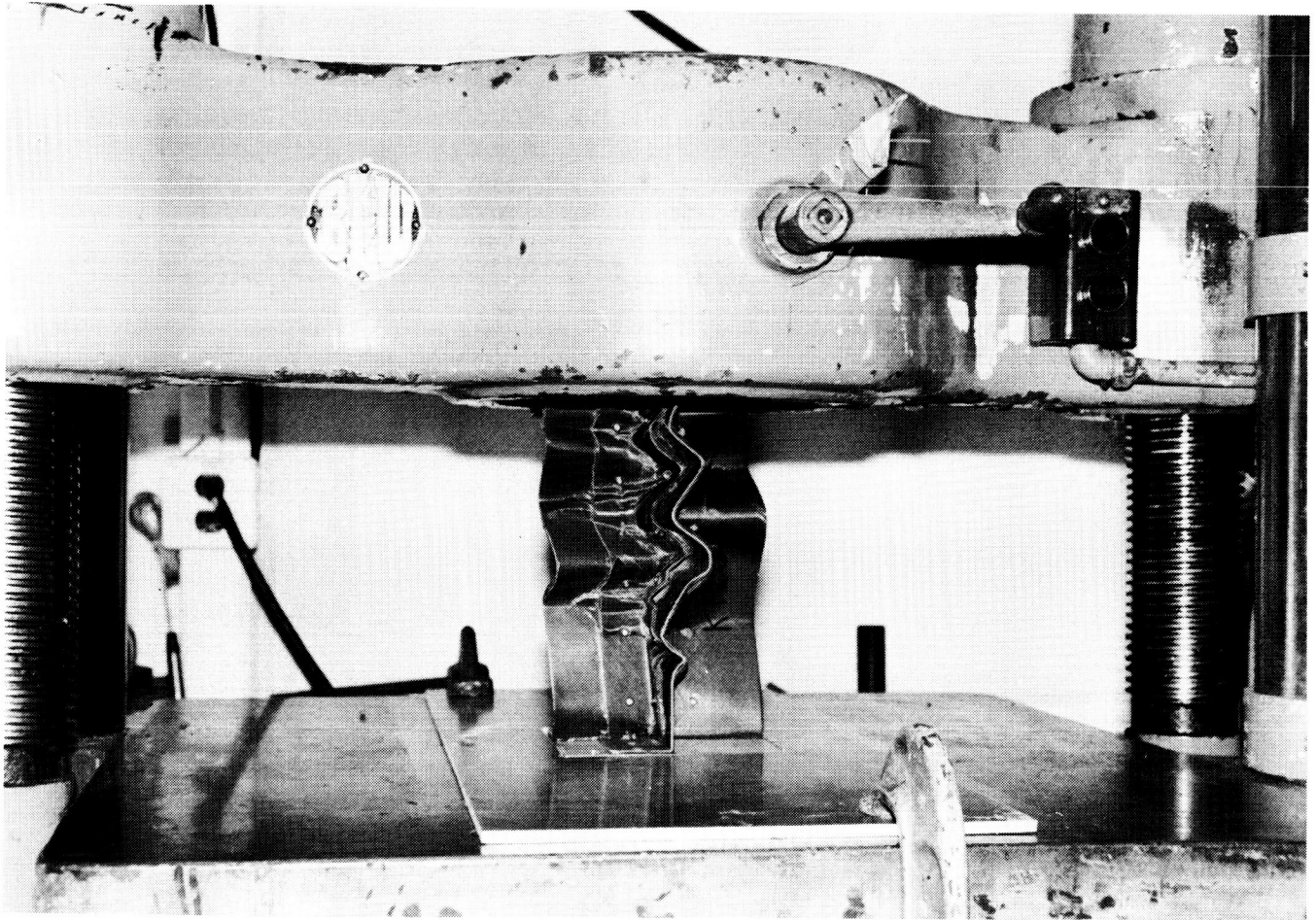

L-89-118

Figure 3. Cruciform in 120 000-lbf test machine.

ORIGINAL PAGE  
BLACK AND WHITE PHOTOGRAPH

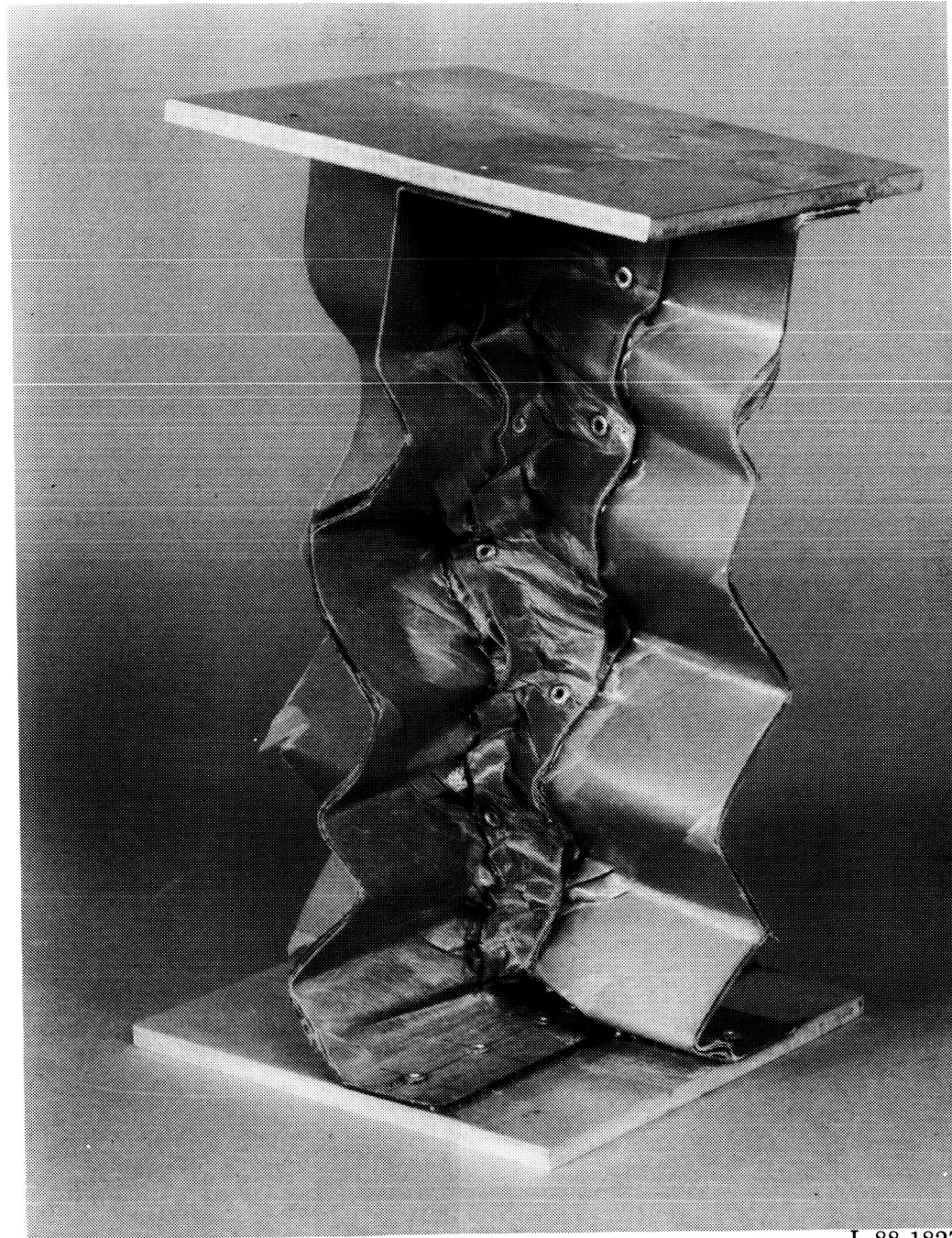

L-88-1827

Figure 4. Crushed Kevlar 12-in. tapered specimen without cutouts (K1200T). The accordionlike buckling is typical of the Kevlar TWOCO specimens.

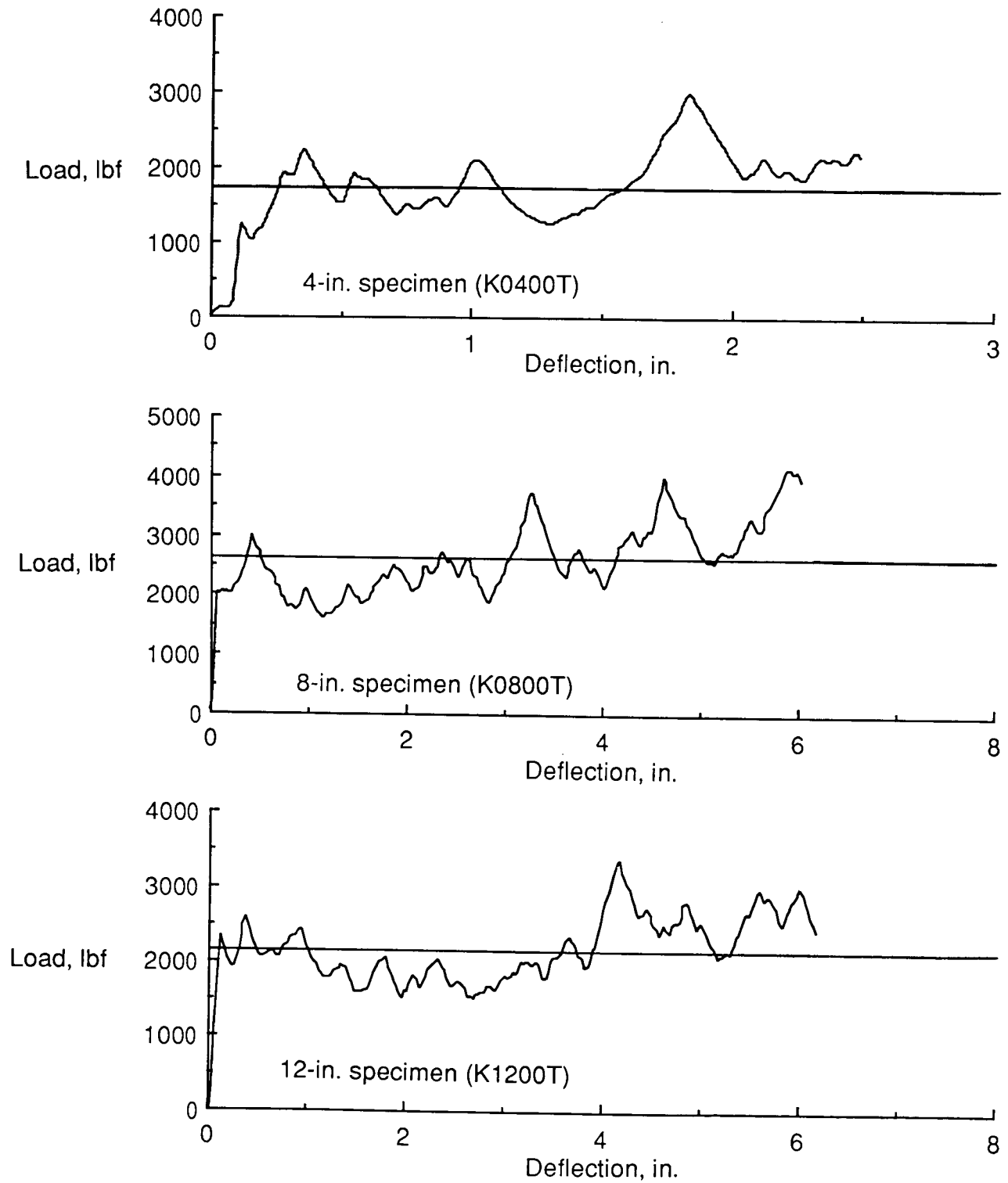
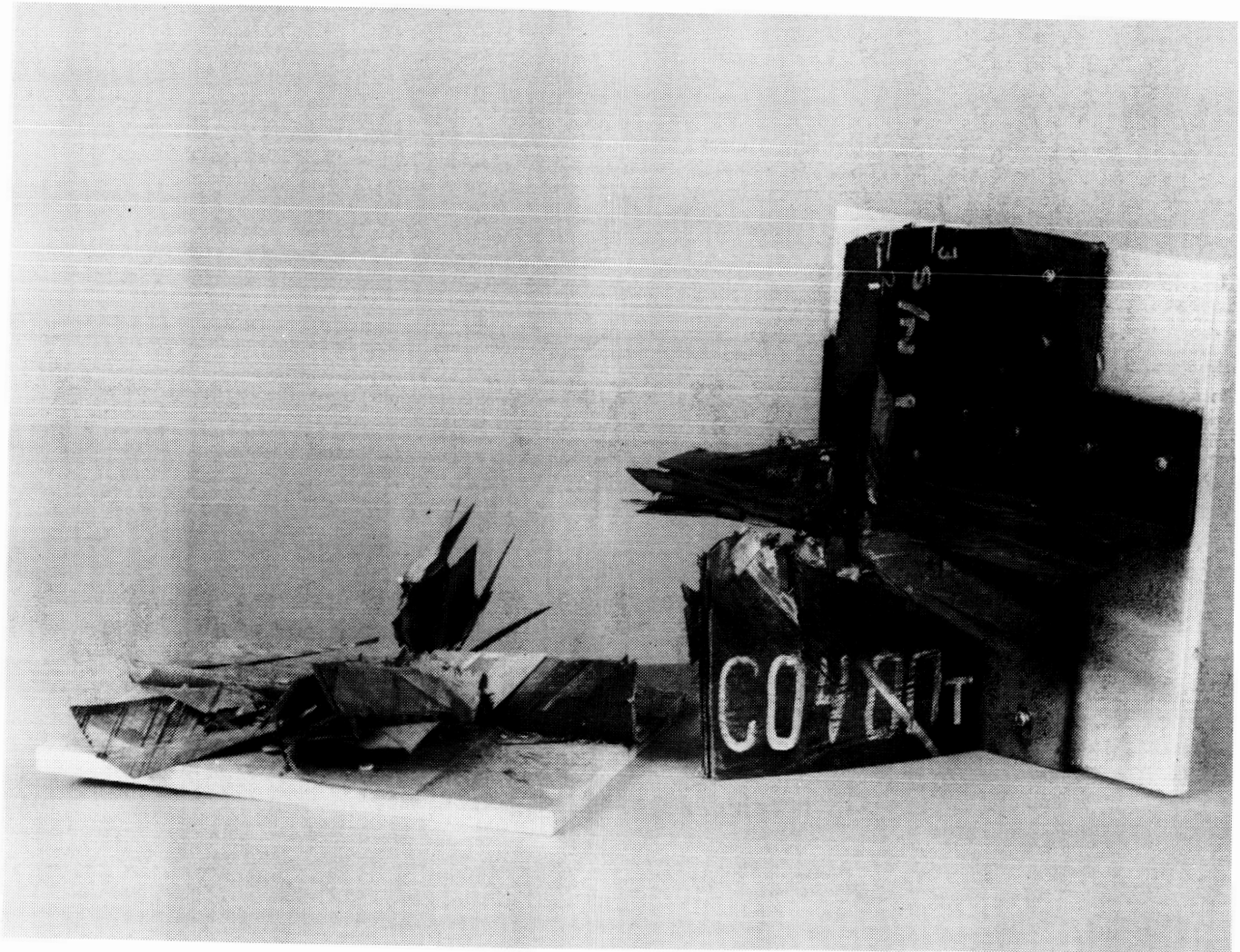

Figure 5. Typical load-deflection data for Kevlar tapered load specimens without cutouts (TWOCO). Solid line denotes sustained crushing load.

ORIGINAL PAGE  
BLACK AND WHITE PHOTOGRAPH



L-88-1831

Figure 6. Crushed graphite-epoxy 4-in. tapered specimen without cutouts (C0400T). Loss of structural integrity is typical of the graphite-epoxy TWOCO specimens.

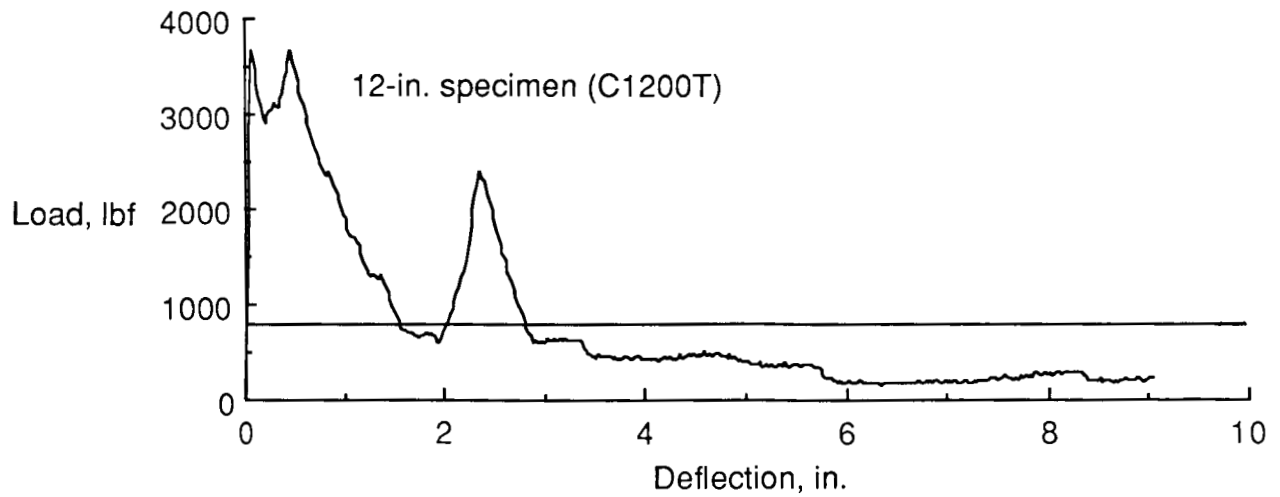
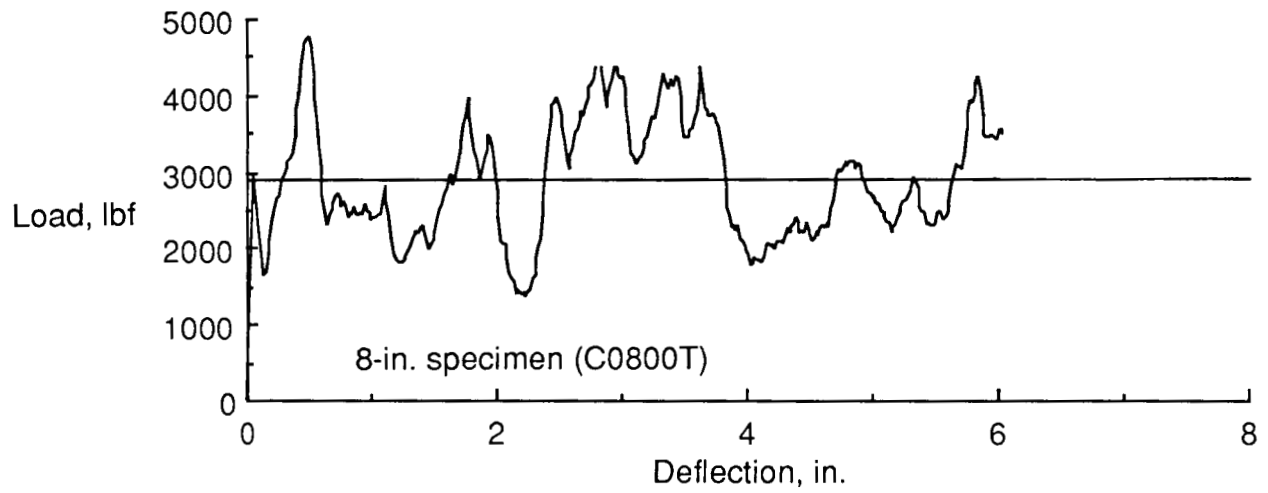
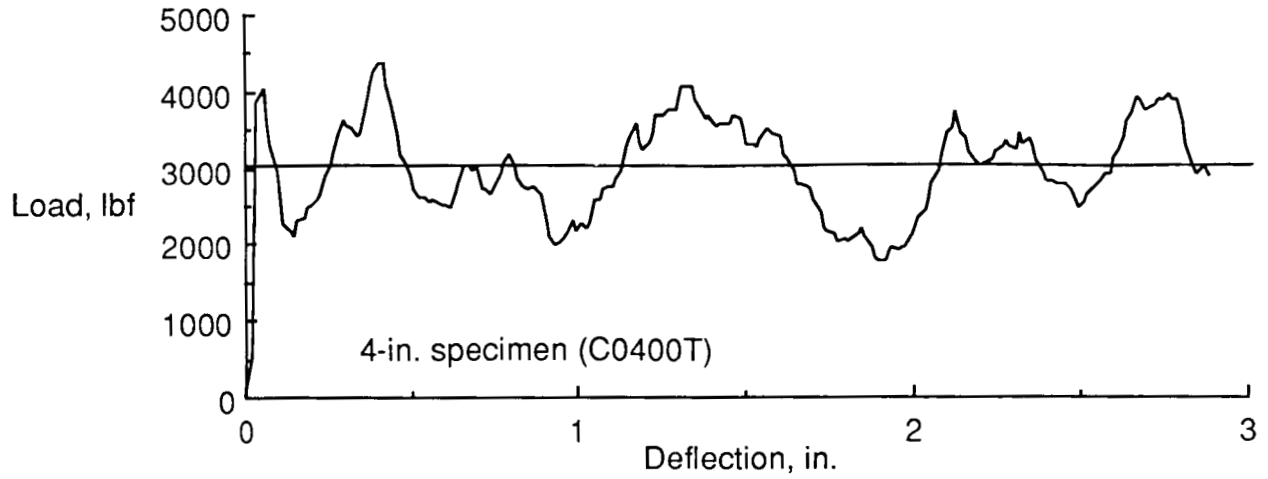
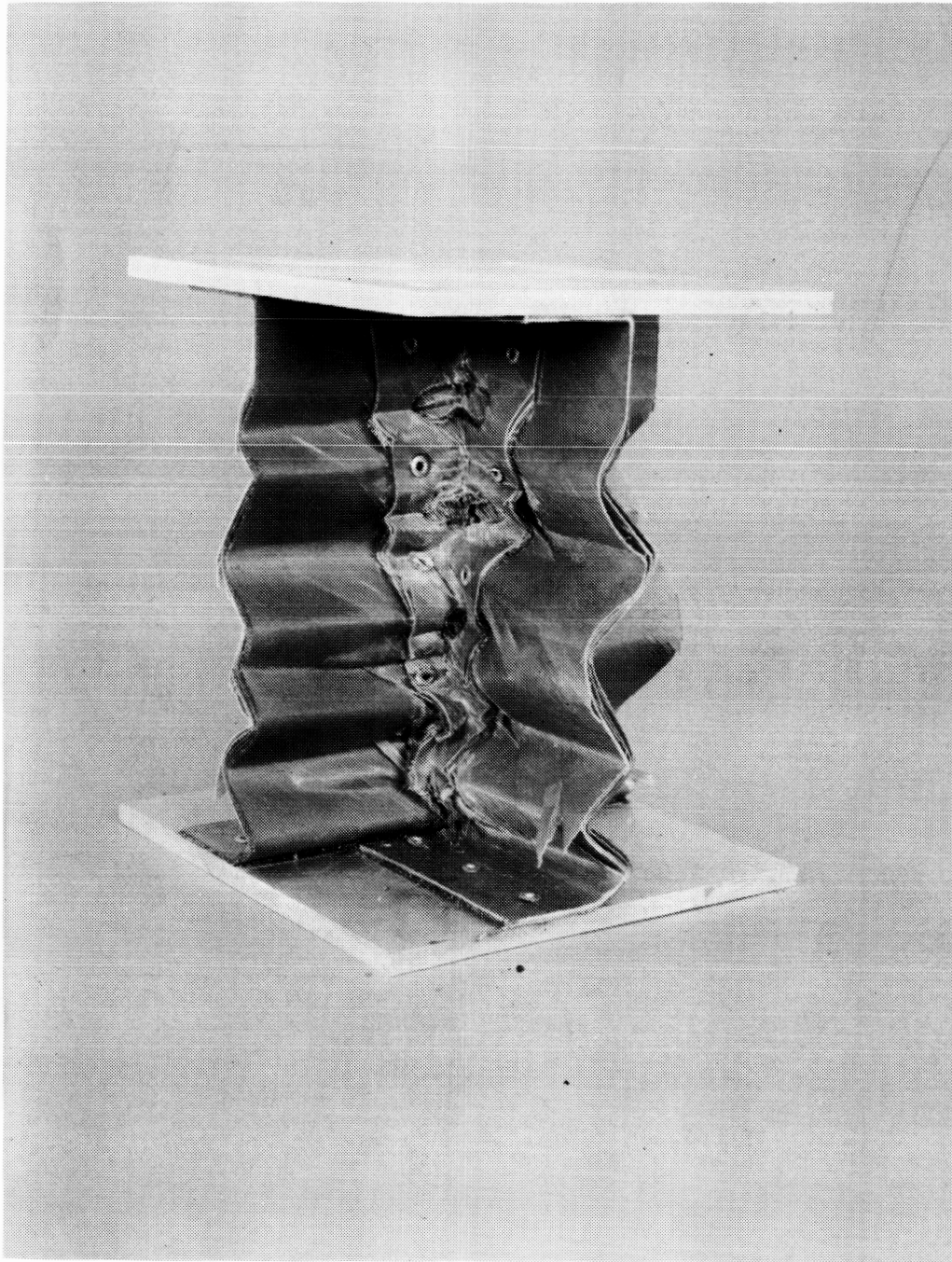

Figure 7. Typical load-deflection data for graphite-epoxy tapered specimens without cutouts (TWOCO). Solid line denotes sustained crushing load.



ORIGINAL PAGE  
BLACK AND WHITE PHOTOGRAPH



L-88-13,258

- (a) Crushed Kevlar 8-in. tapered specimen with four cutouts (K0804T). Note the accordionlike buckling and good structural integrity.

Figure 8. Kevlar TWCO specimens.

ORIGINAL PAGE  
BLACK AND WHITE PHOTOGRAPH

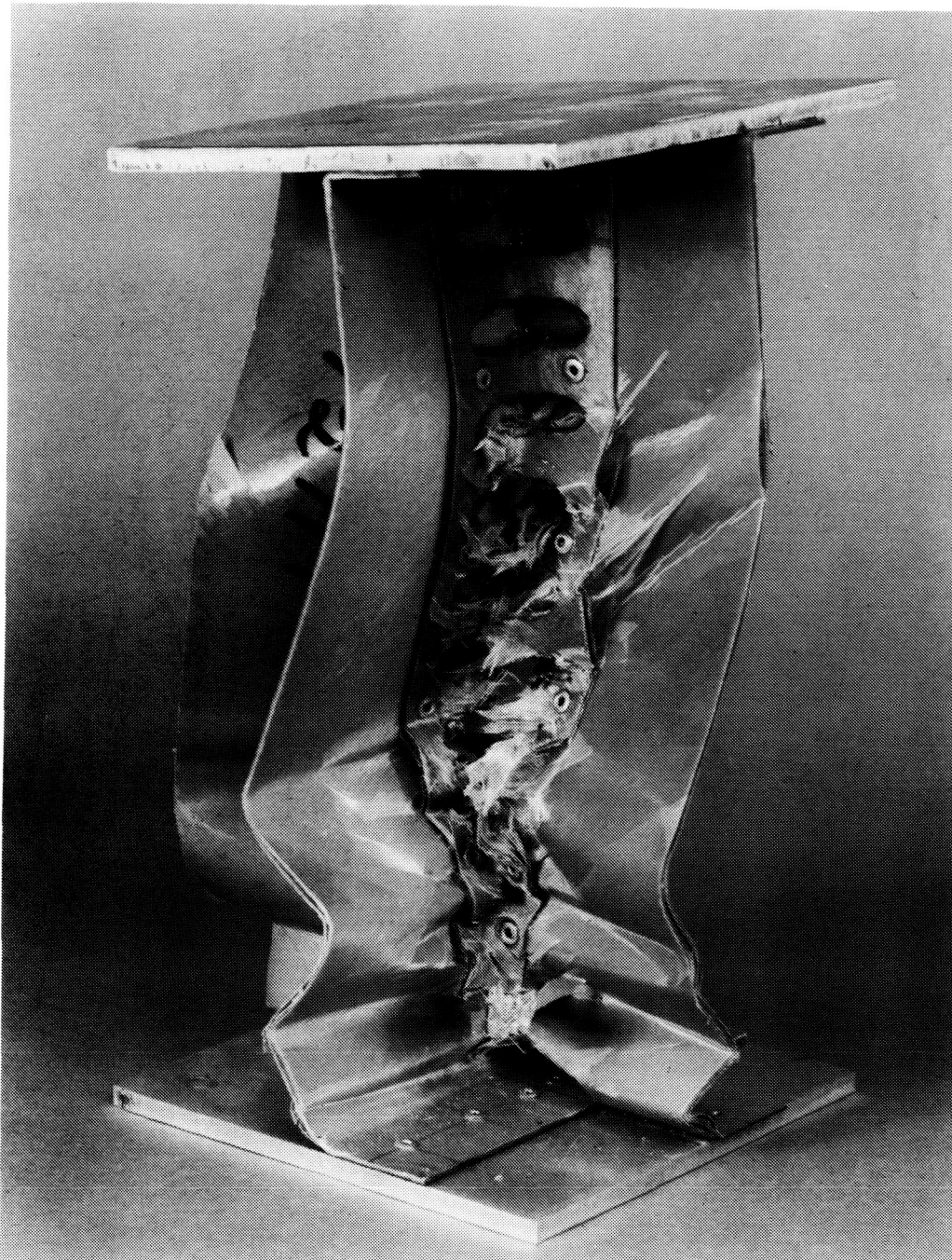

L-88-1826

(b) Crushed Kevlar 12-in. tapered specimen with 11 cutouts (K1211T). Note the global buckling and delamination of intersection.

Figure 8. Concluded.

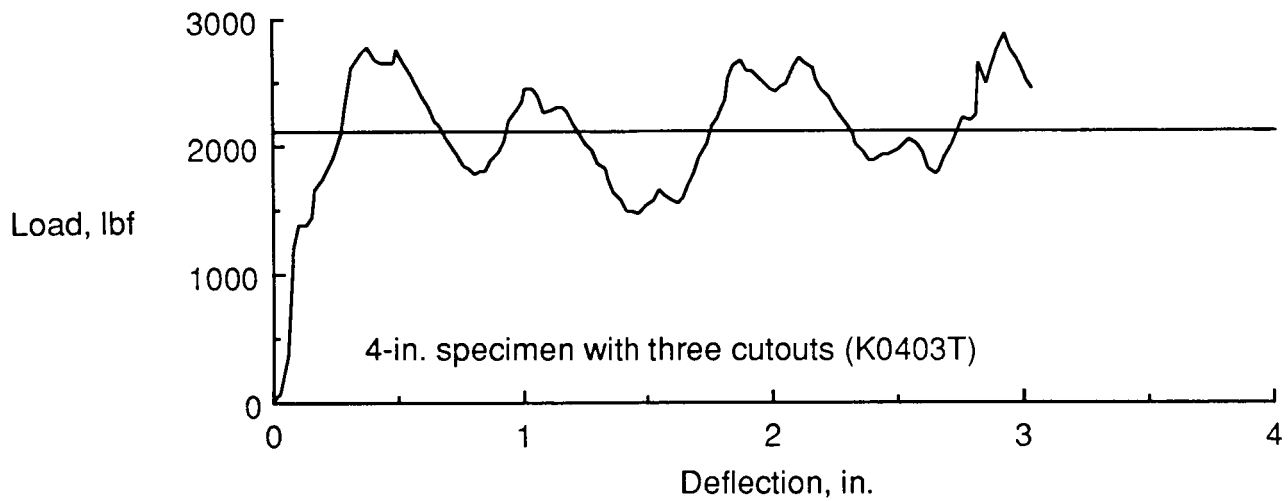
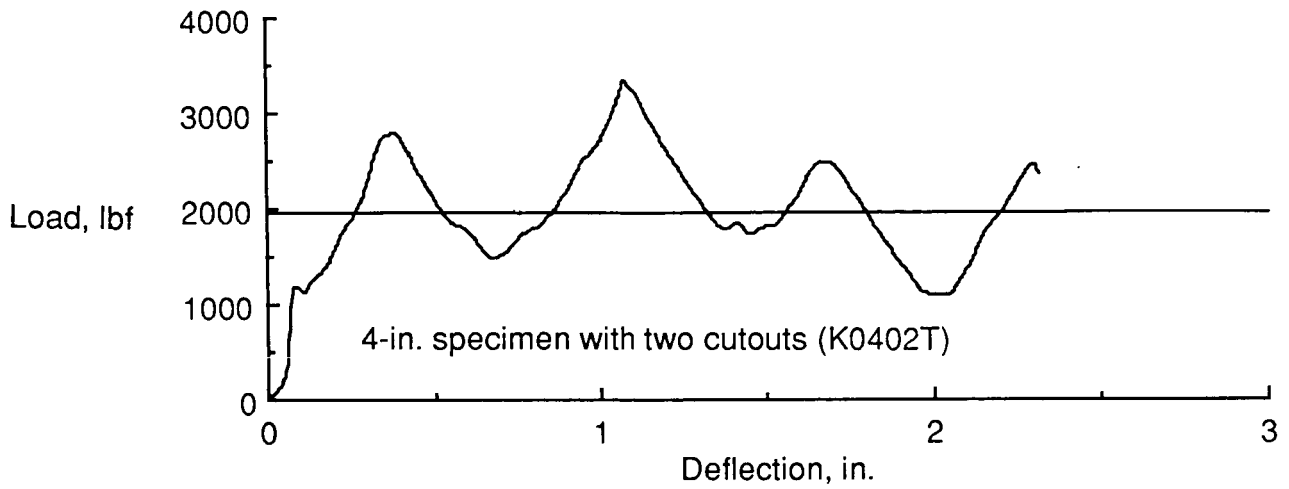

(a) Typical load-deflection data for Kevlar 4-in. tapered specimens with two and three cutouts.

Figure 9. Typical load-deflection data for Kevlar tapered specimens with cutouts (TWCO). Solid line denotes sustained crushing load.

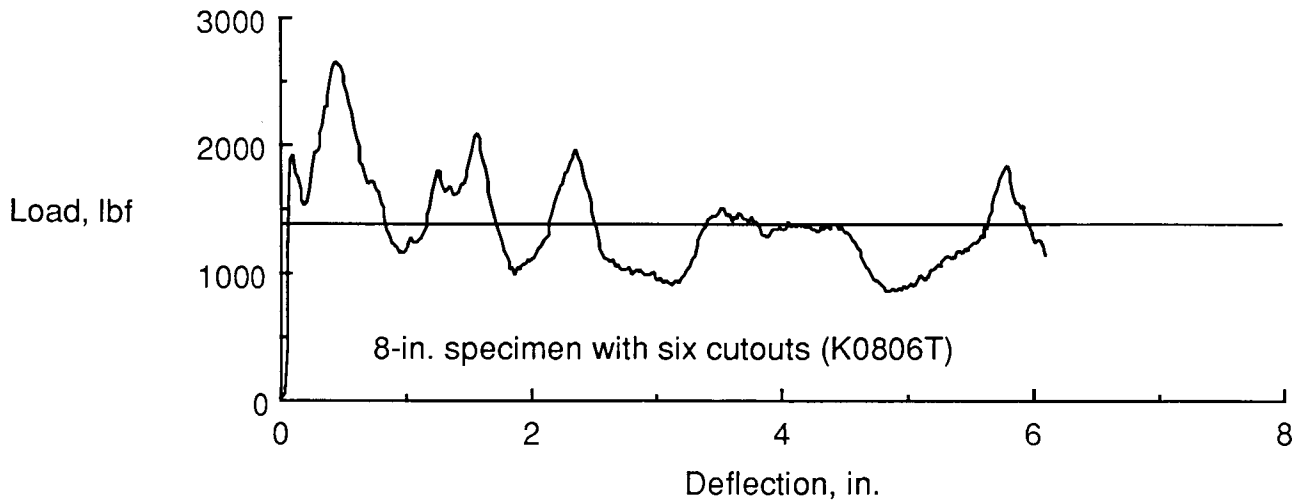
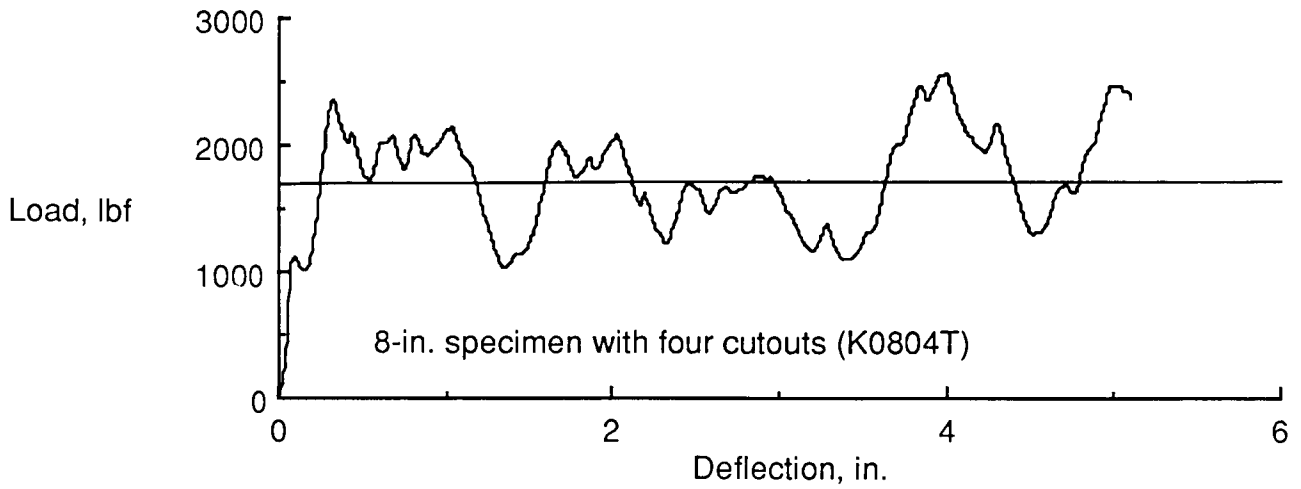

(b) Typical load-deflection data for Kevlar 8-in. tapered specimens with four and six cutouts.

Figure 9. Continued.

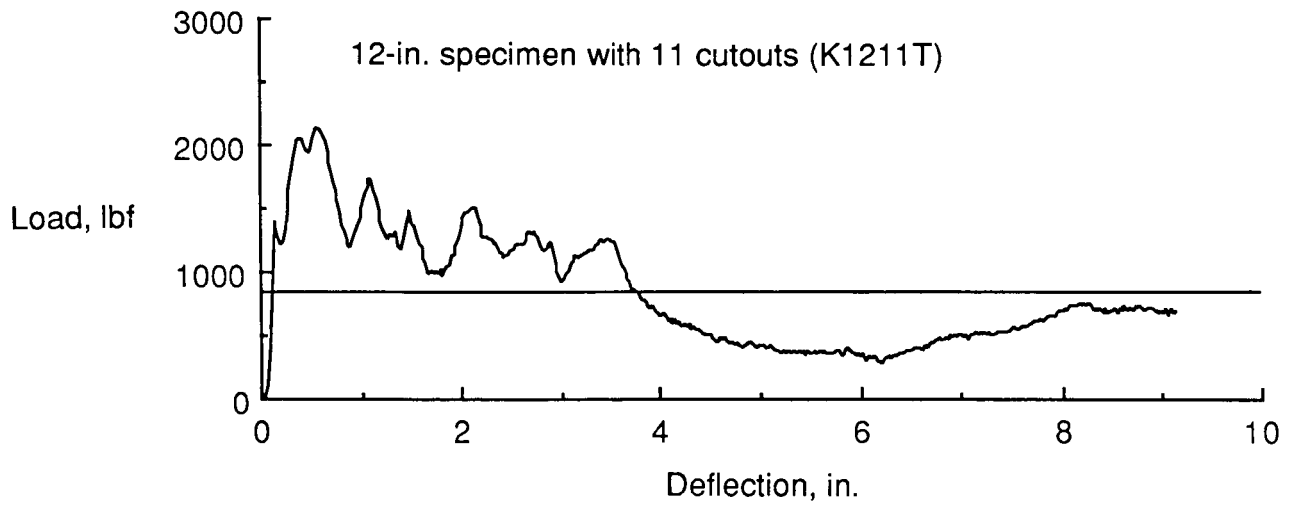
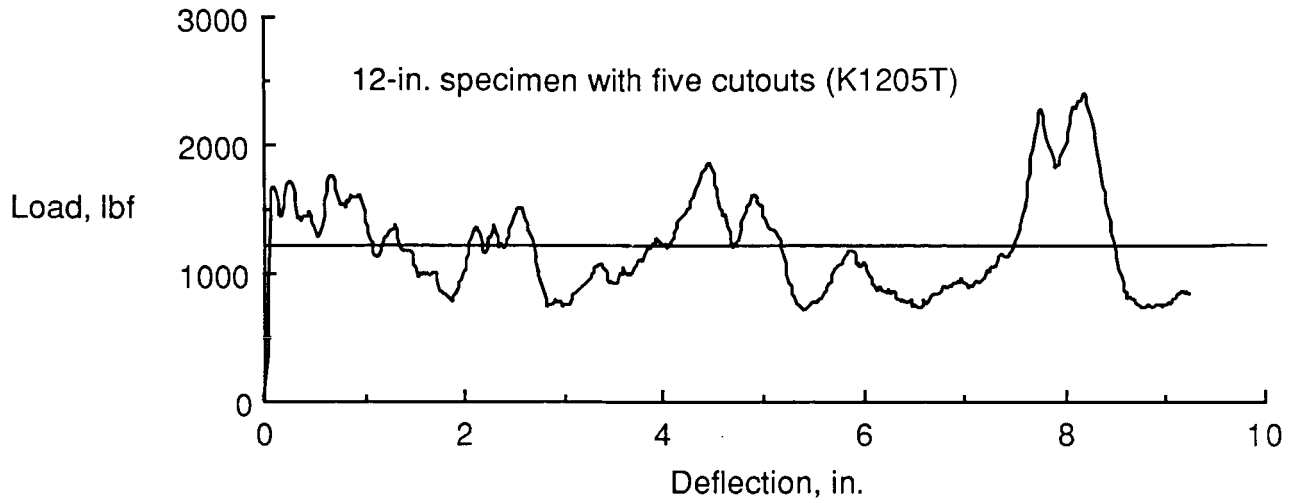

(c) Typical load-deflection data for Kevlar 12-in. tapered specimens with 5 and 11 cutouts.

Figure 9. Concluded.

ORIGINAL PAGE  
BLACK AND WHITE PHOTOGRAPH

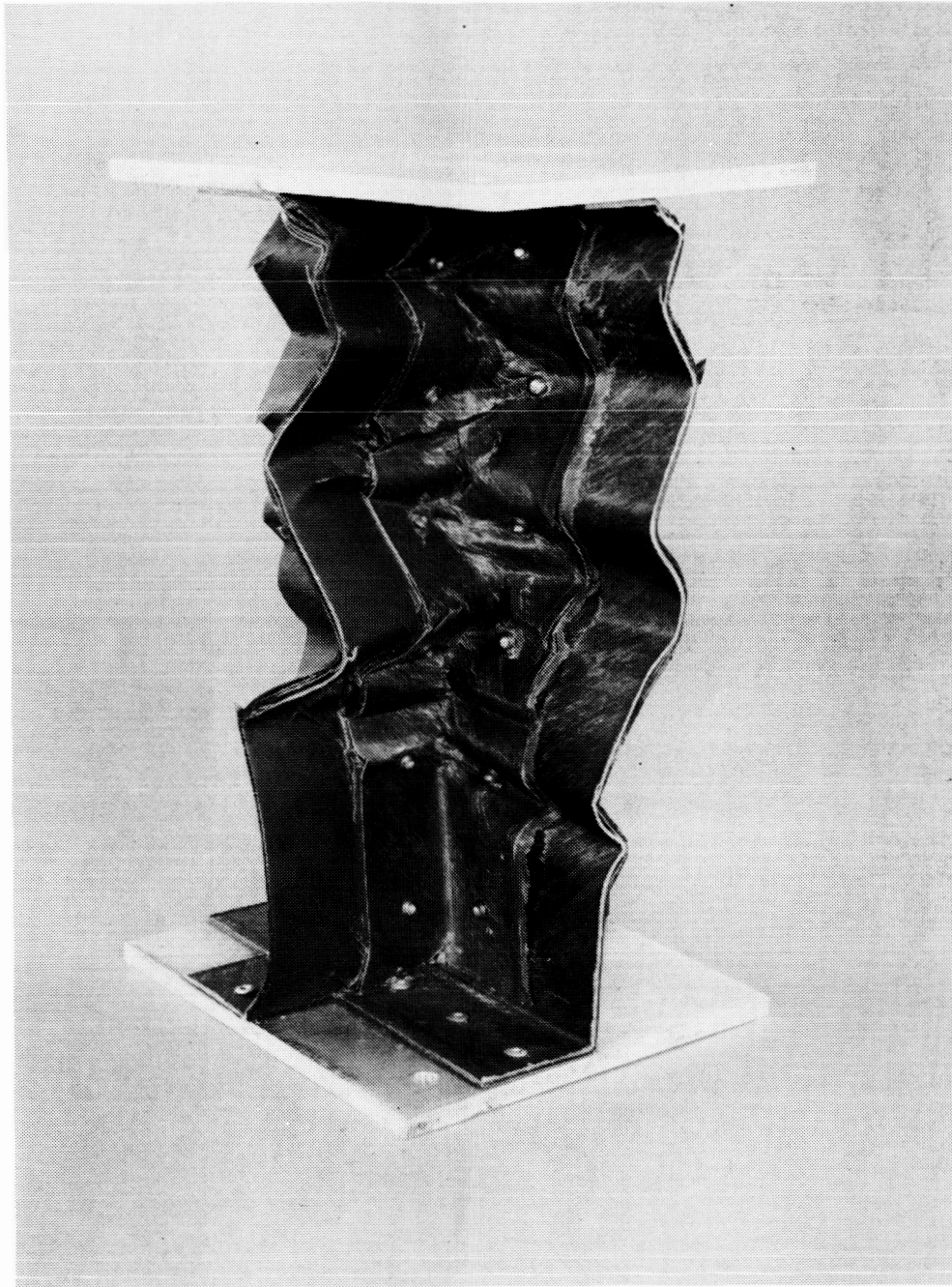

L-88-13,254

Figure 10. Crushed Kevlar 12-in. straight specimen without cutouts (K1200S). The accordionlike buckling is typical of the Kevlar SWOCO specimens.

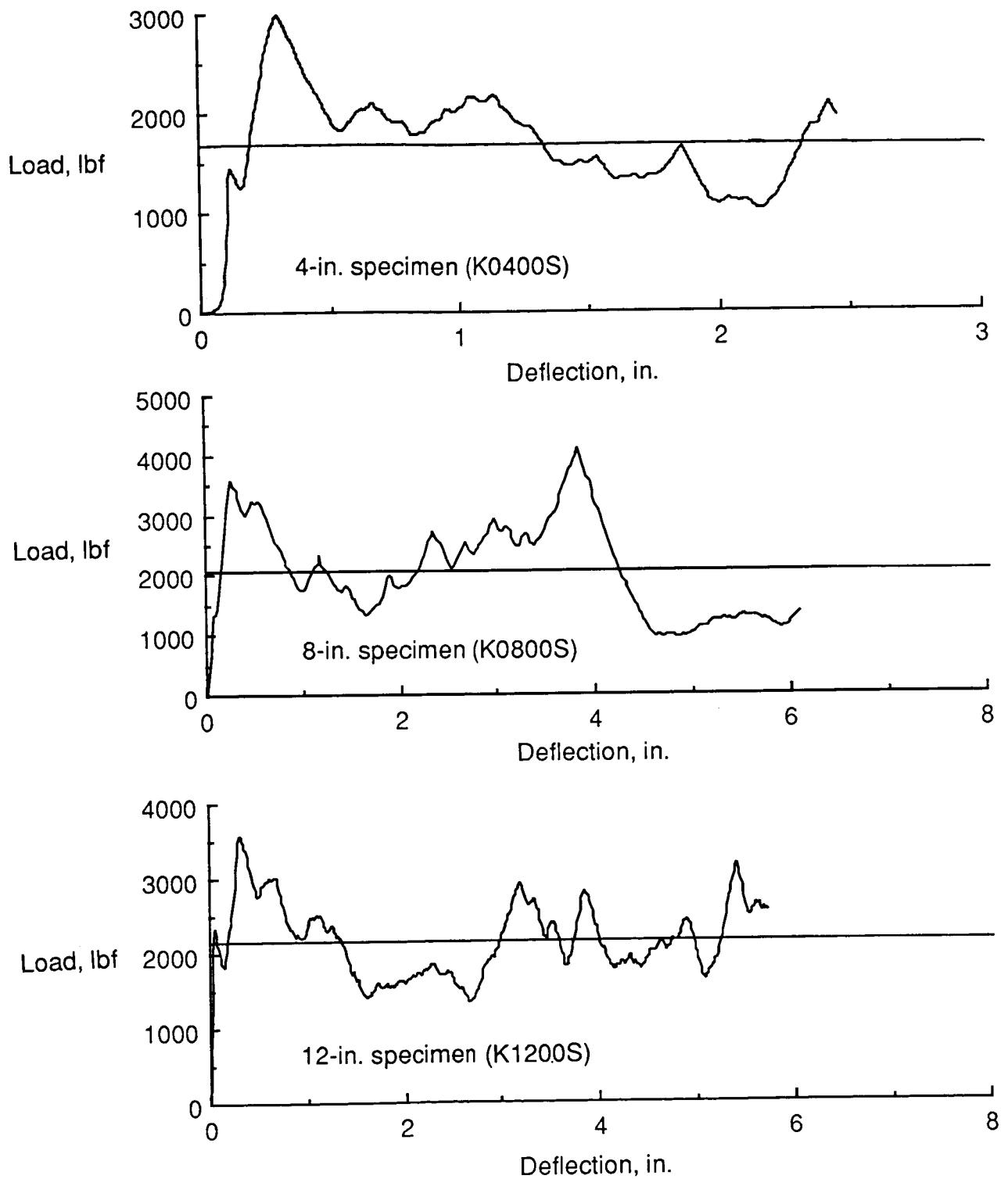
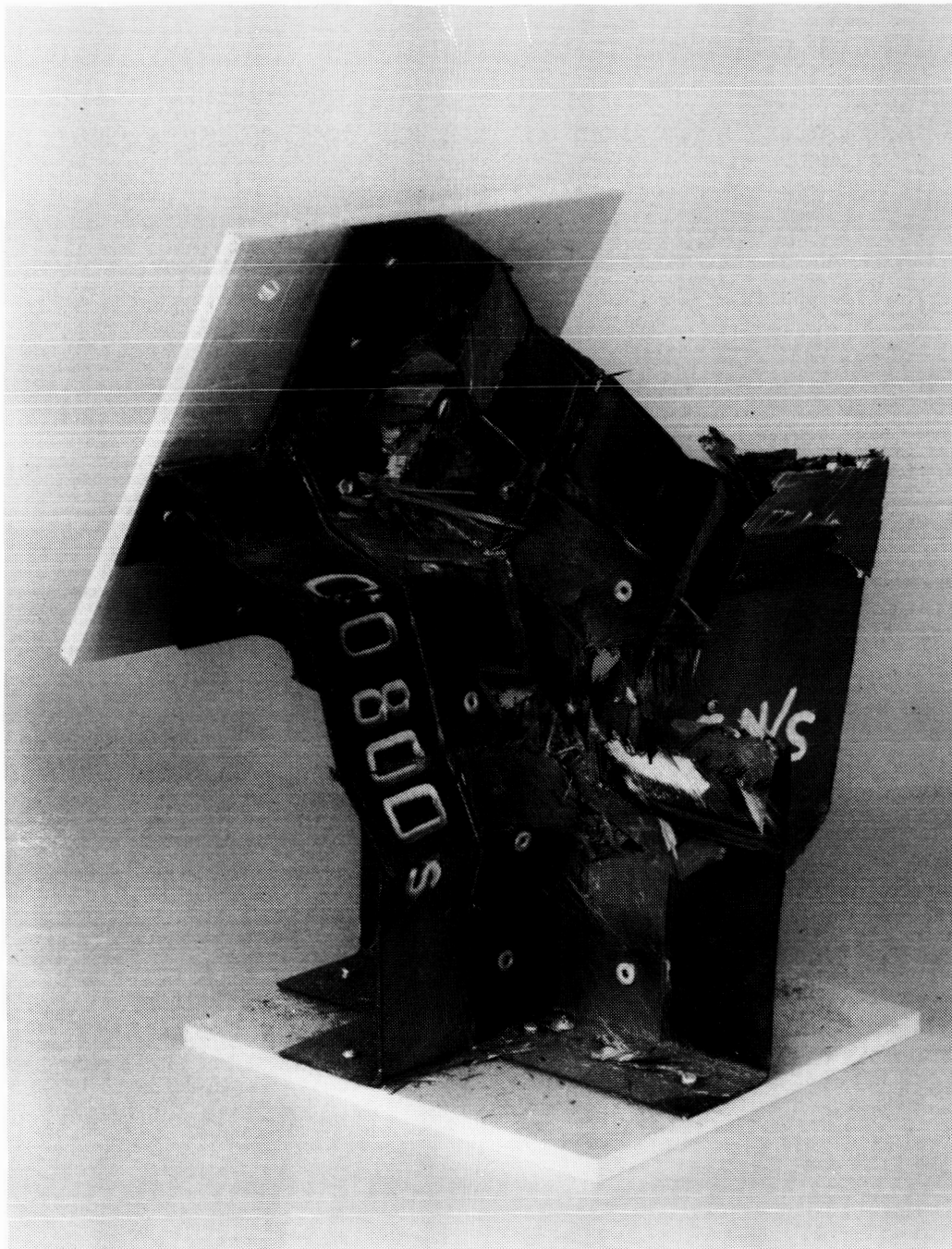

Figure 11. Typical load-deflection data for Kevlar straight specimens without cutouts (SWOCO). Solid line denotes sustained crushing load.

ORIGINAL PAGE  
BLACK AND WHITE PHOTOGRAPH



L-88-1829

Figure 12. Crushed graphite-epoxy 8-in. straight specimen without cutouts (C0800S). Note that the loss of structural integrity is not as severe for this specimen.



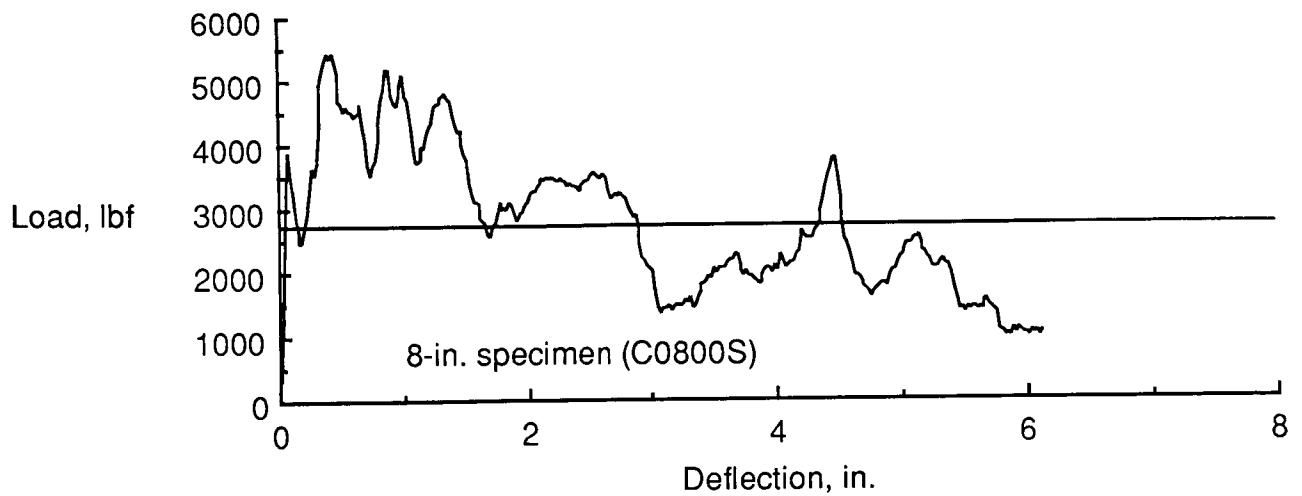
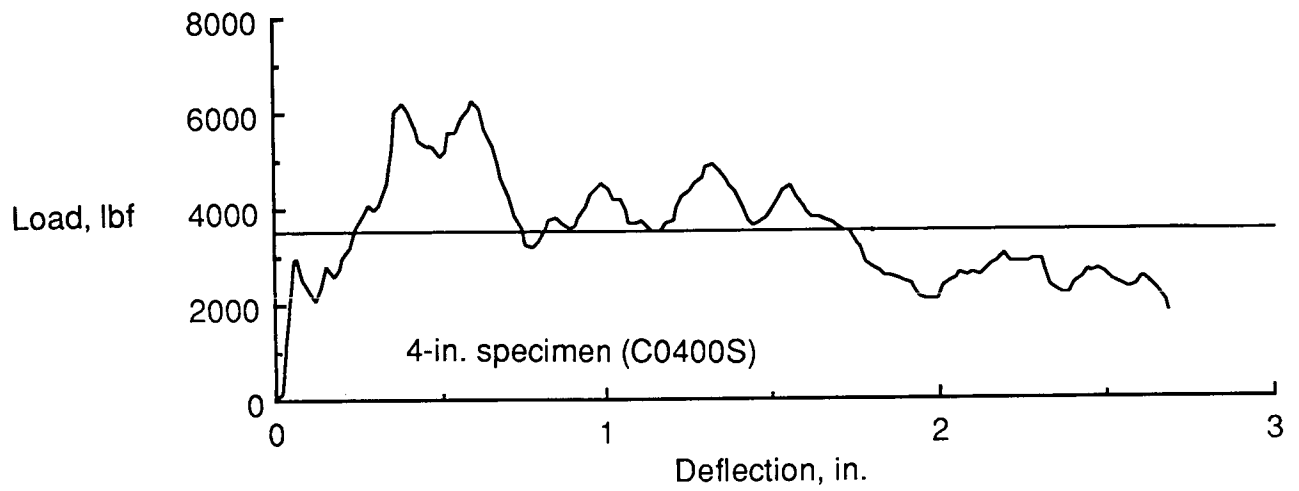
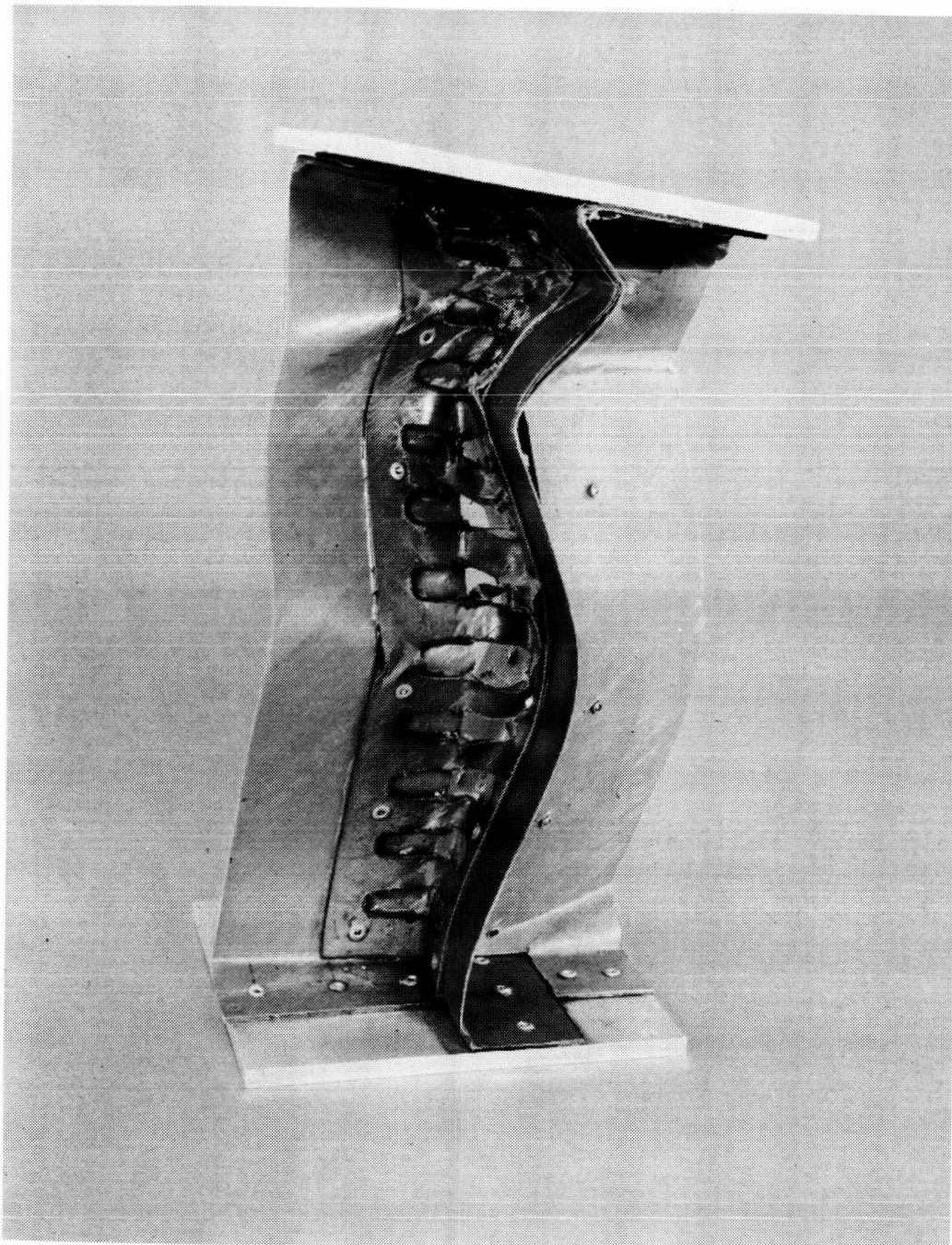

Figure 13. Typical load-deflection data for graphite-epoxy straight specimens without cutouts (SWOCO). Solid line denotes sustained crushing load.

ORIGINAL PAGE  
BLACK AND WHITE PHOTOGRAPH



L-88-13,260

Figure 14. Crushed Kevlar 12-in. straight specimen with 11 cutouts (K1211S). Note the global buckling and delamination of intersection.

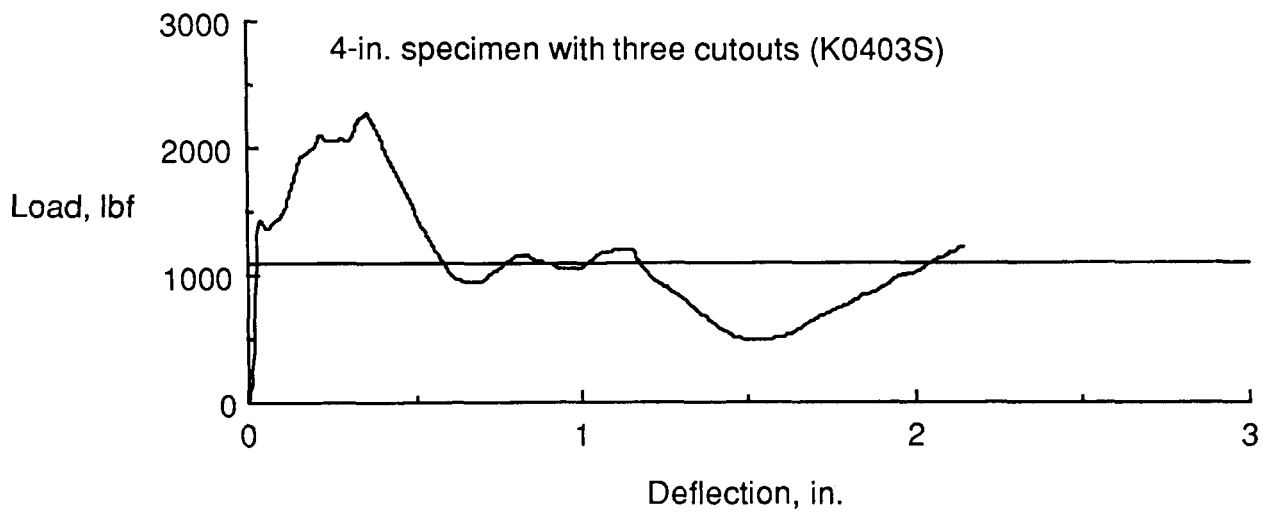
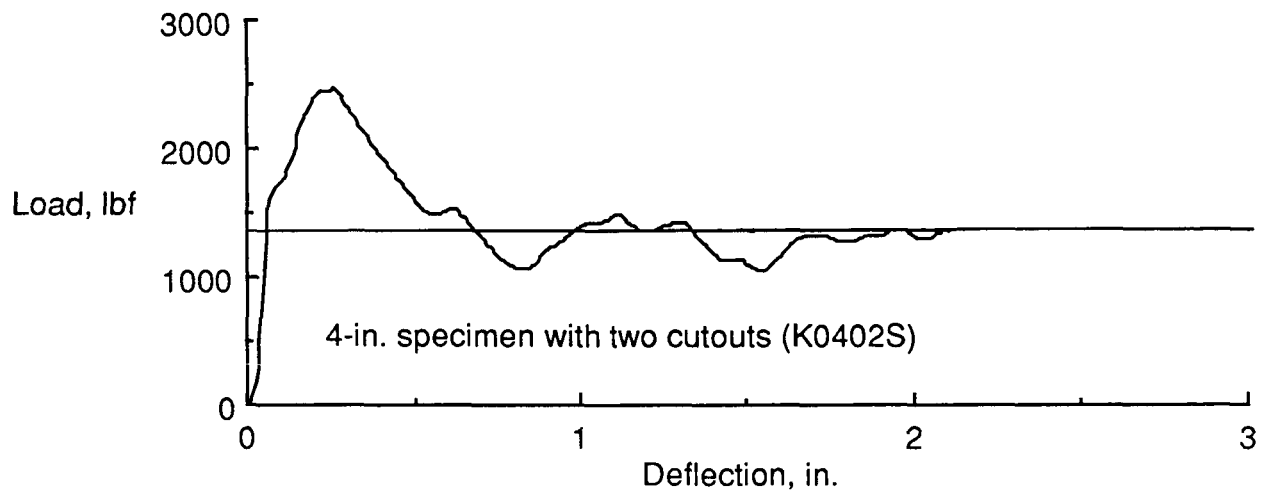

(a) Typical load-deflection data for Kevlar 4-in. straight specimens with two and three cutouts.

Figure 15. Typical load-deflection data for Kevlar straight specimens with cutouts (SWCO). Solid line denotes sustained crushing load.

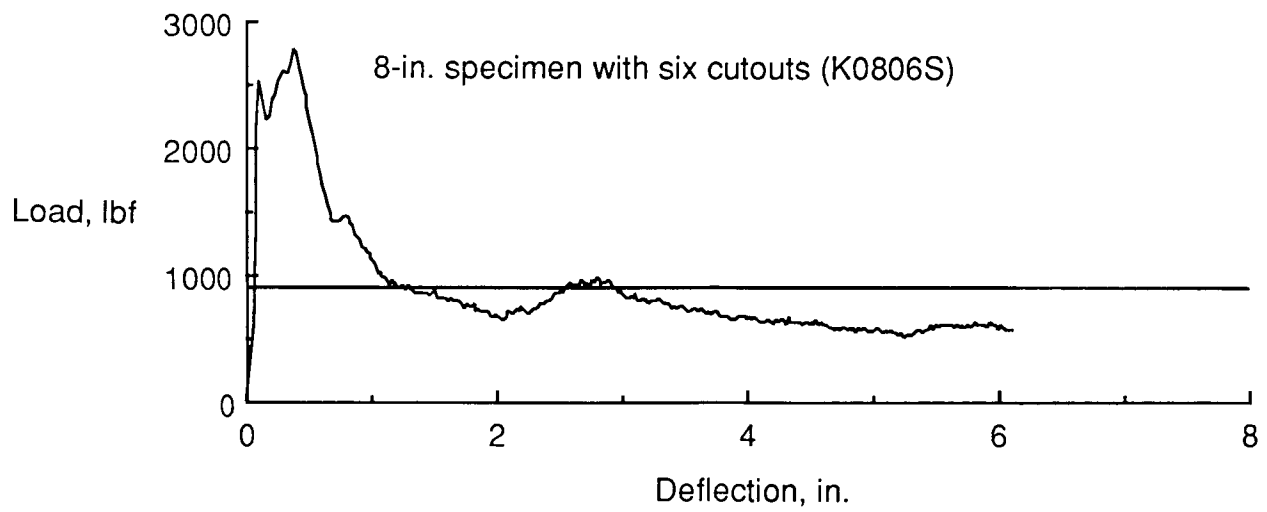
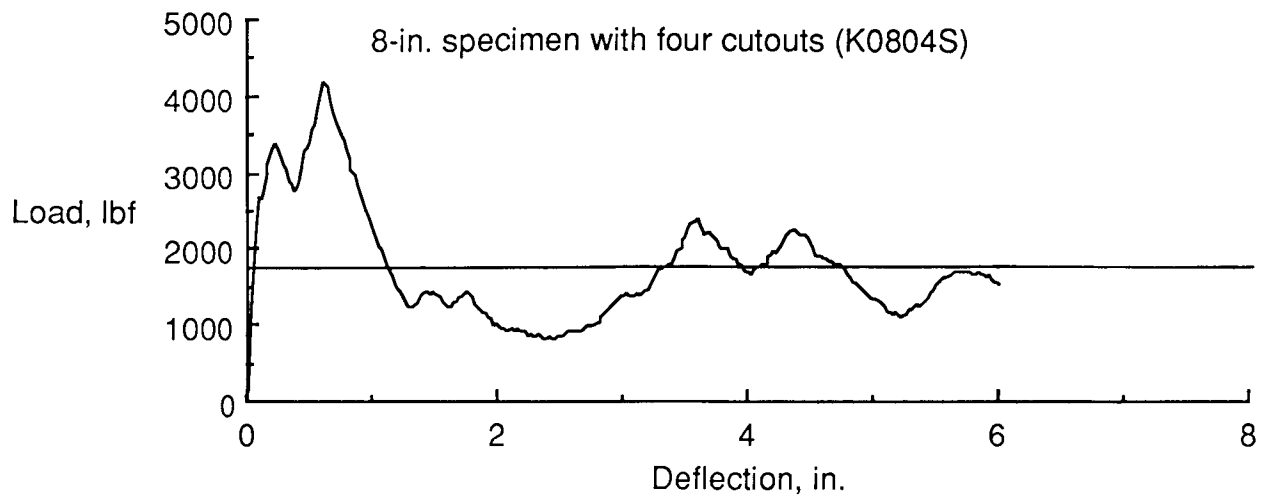

(b) Typical load-deflection data for Kevlar 8-in. straight specimens with four and six cutouts.

Figure 15. Continued.

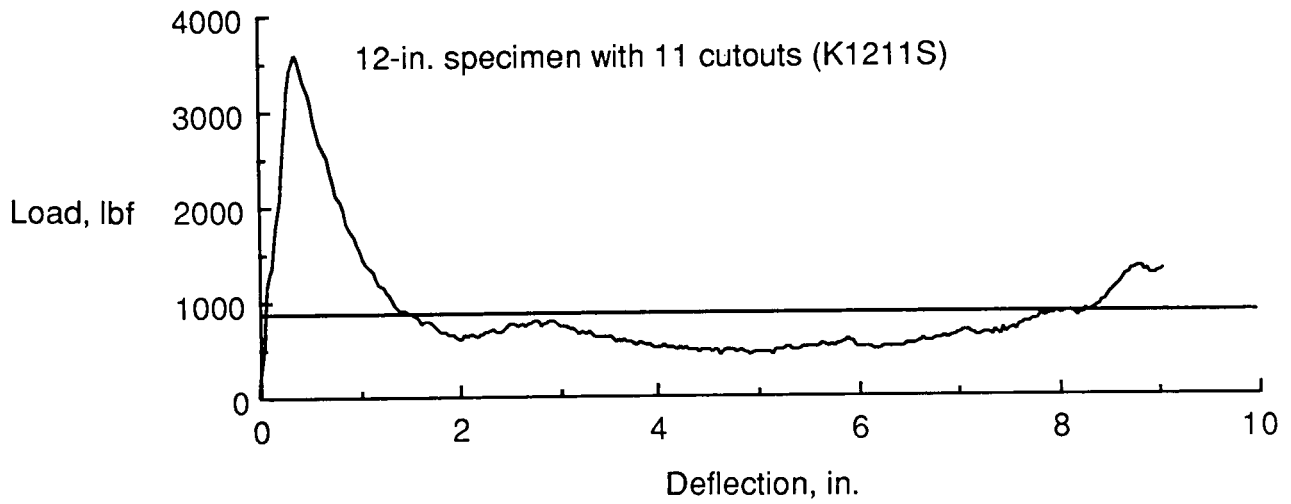
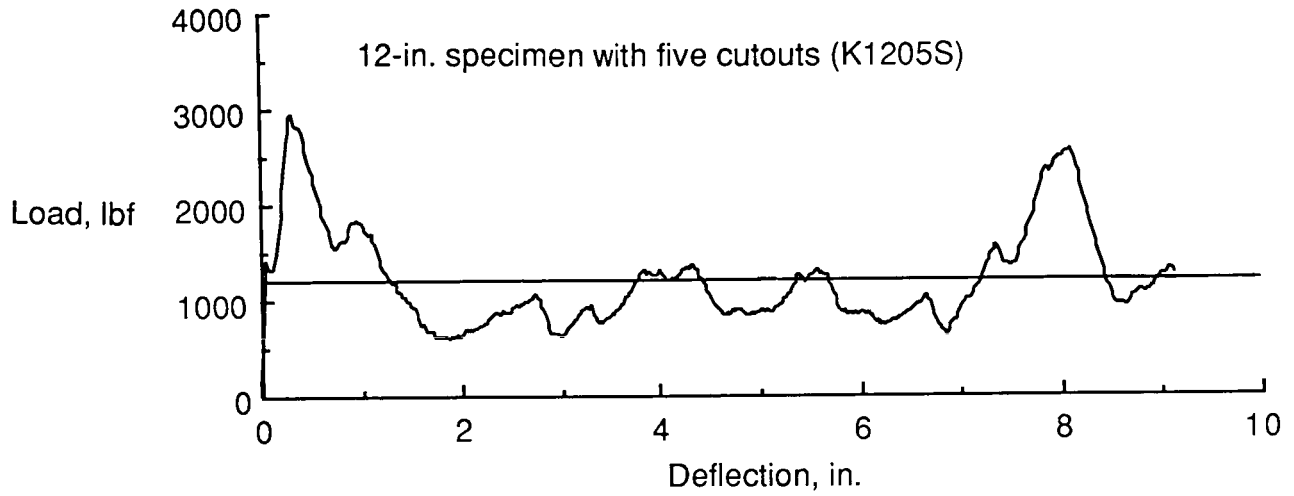

(c) Typical load-deflection data for Kevlar 12-in. straight specimens with 5 and 11 cutouts.

Figure 15. Concluded.

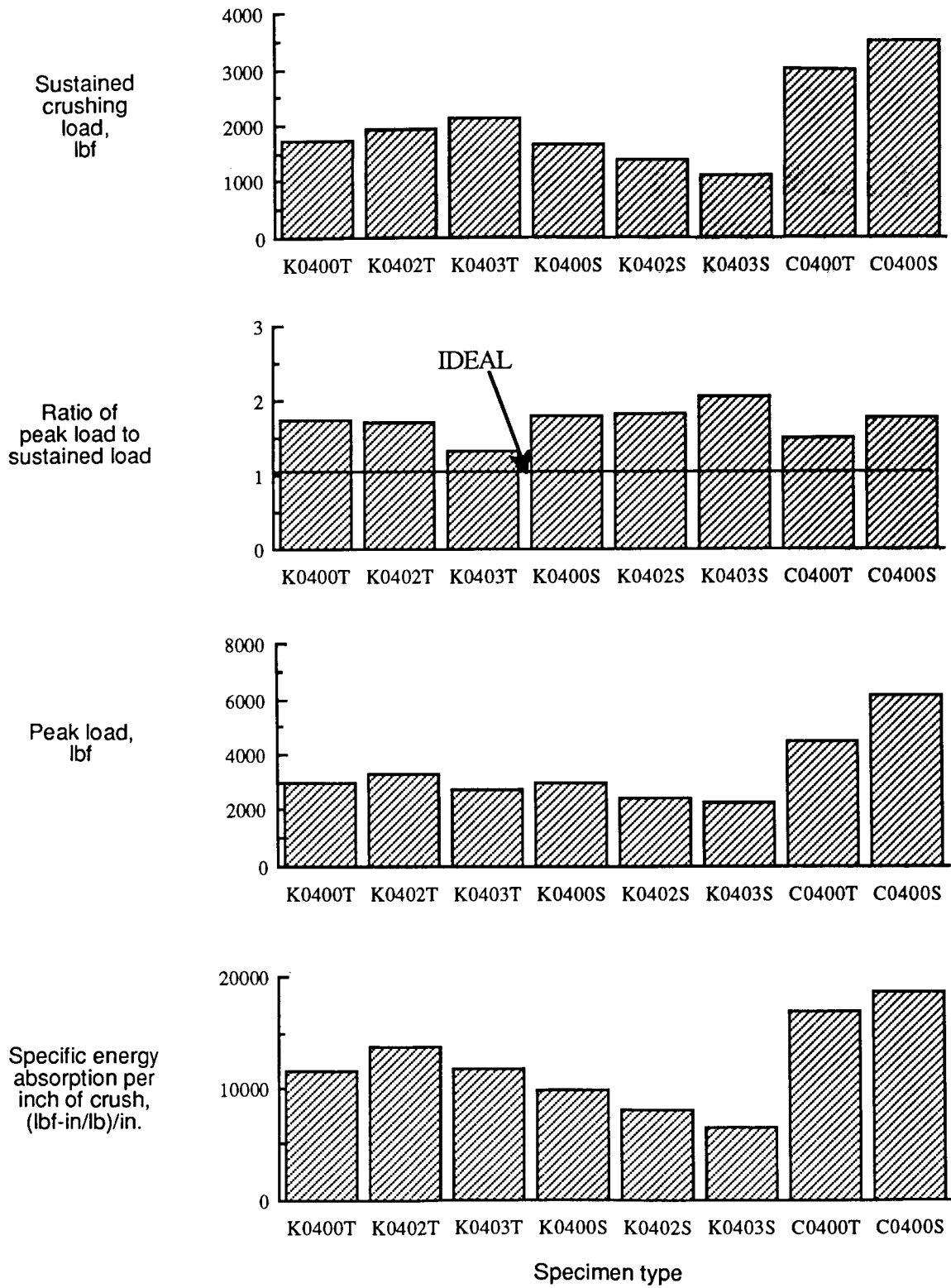

(a) 4-in. specimens.

Figure 16. Comparison of performance of composite subfloor intersections.

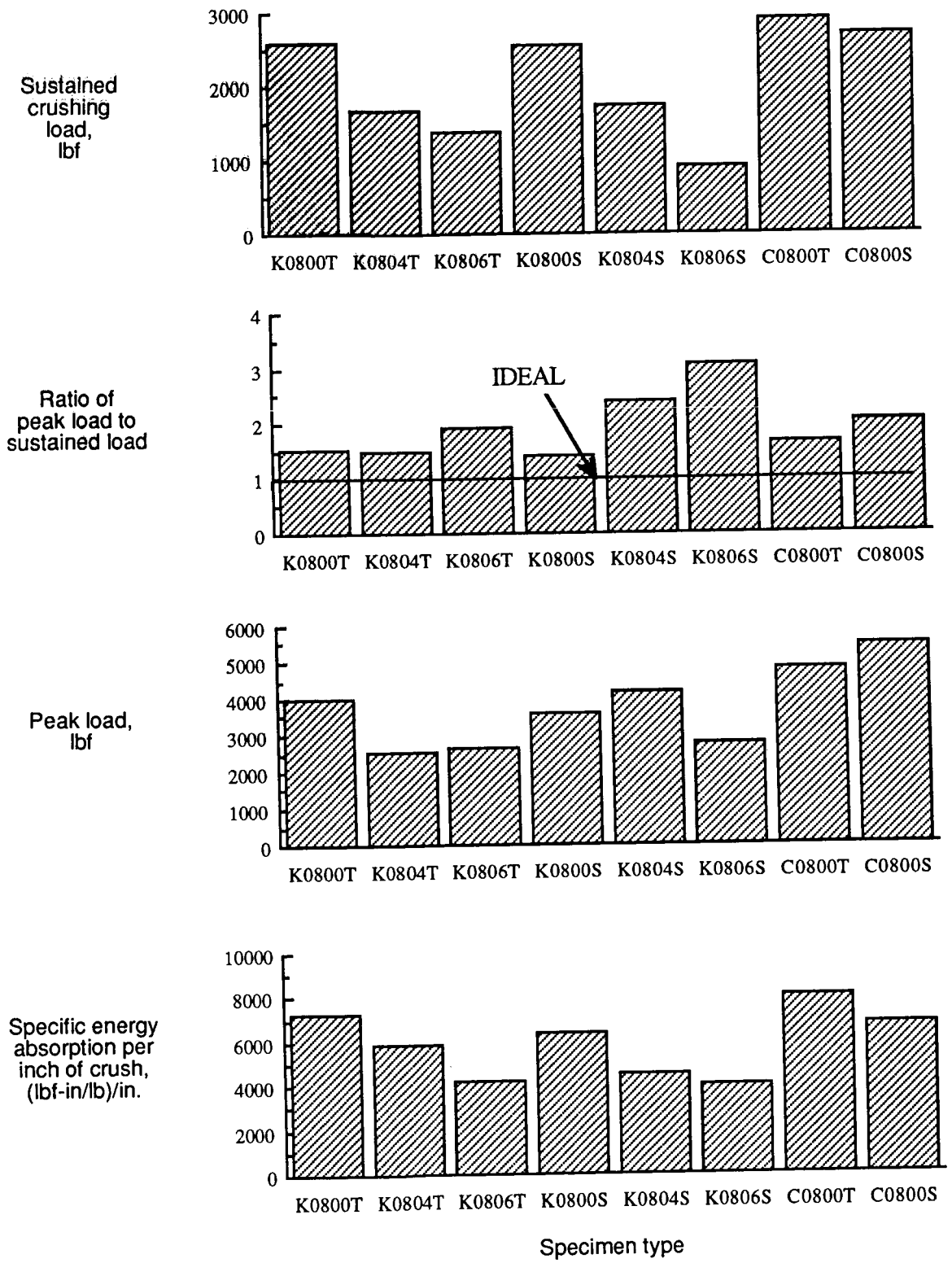

(b) 8-in. specimens.

Figure 16. Continued.

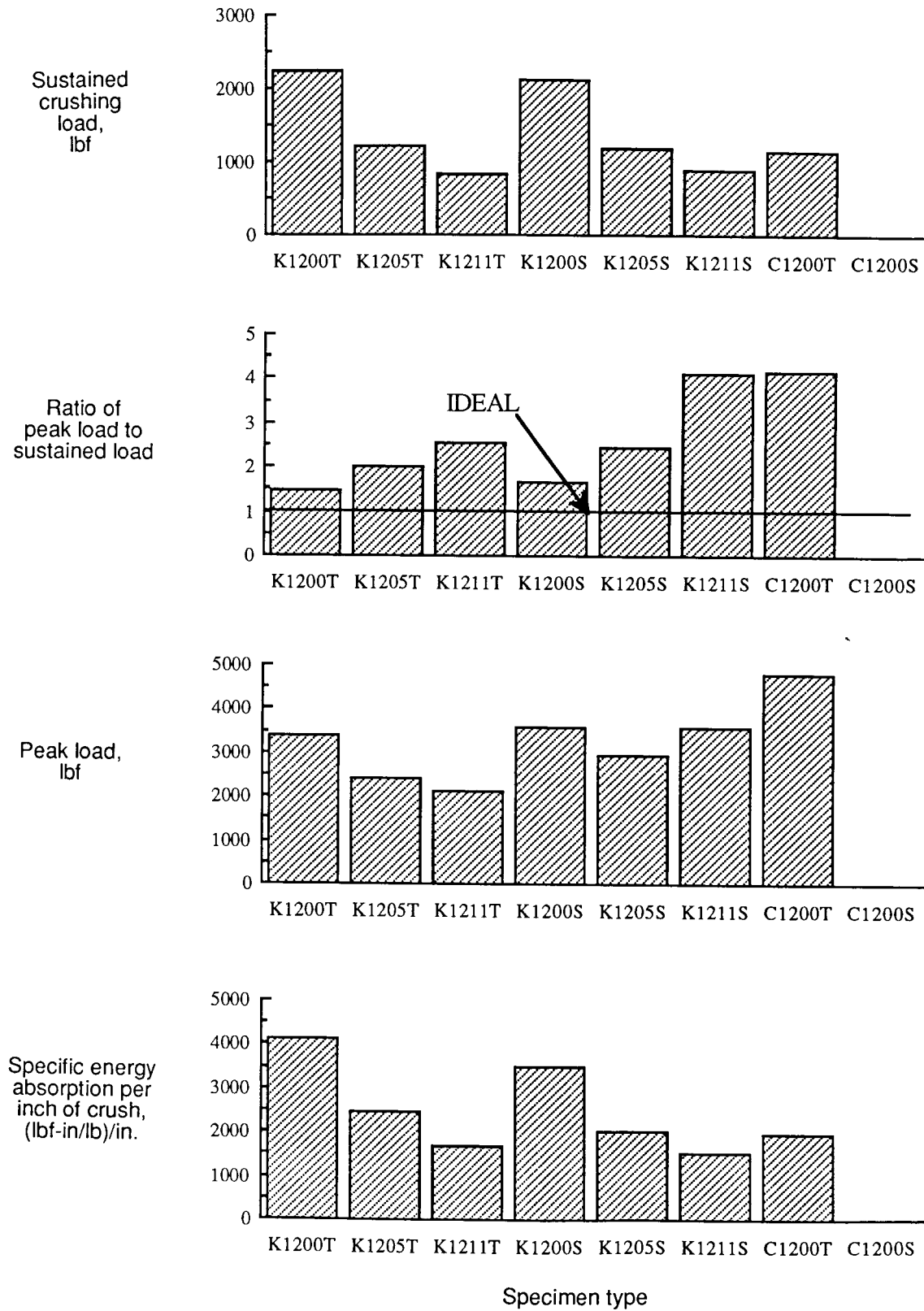

(c) 12-in. specimens.

Figure 16. Concluded.





### Report Documentation Page

1. Report No. NASA TP-2951	2. Government Accession No.	3. Recipient's Catalog No.	
4. Title and Subtitle Evaluation of Energy Absorption of New Concepts of Aircraft Composite Subfloor Intersections		5. Report Date November 1989	6. Performing Organization Code
		8. Performing Organization Report No. L-16628	
7. Author(s) Lisa E. Jones and Huey D. Carden		10. Work Unit No. 505-63-01-11	11. Contract or Grant No.
9. Performing Organization Name and Address NASA Langley Research Center Hampton, VA 23665-5225		13. Type of Report and Period Covered Technical Paper	
		14. Sponsoring Agency Code	
12. Sponsoring Agency Name and Address National Aeronautics and Space Administration Washington, DC 20546-0001			
15. Supplementary Notes Lisa E. Jones: PRC Kentron, Inc., Aerospace Technologies Division, Hampton, Virginia. Huey D. Carden: NASA Langley Research Center, Hampton, Virginia.			
16. Abstract Forty-one composite specimens of aircraft subfloor intersections were tested to determine the effects of geometry and material on the energy-absorbing behavior, failure characteristics, and postcrush structural integrity of the specimens. The intersections were constructed of 12-ply ( $[\pm 45]_6$ ) laminates of either Kevlar 49/934 or AS-4/934 graphite epoxy in heights of 4, 8, and 12 in. The geometry of the specimens varied in the designs of the intersection attachment angle. Four different geometries were tested.			
17. Key Words (Suggested by Authors(s)) Composite material Crashworthiness Subfloor intersections Energy absorption		18. Distribution Statement Unclassified—Unlimited  Subject Category 05	
19. Security Classif. (of this report) Unclassified	20. Security Classif. (of this page) Unclassified	21. No. of Pages 31	22. Price A03