

*NASA-CR 183904*

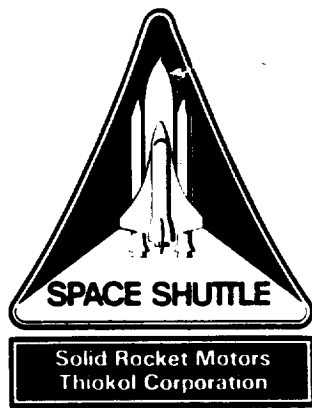

TWR-17544 Vol IV

FLIGHT SET 360H005 (STS-28)  
SEALS FINAL REPORT

February 1990

**Prepared for:**

**NATIONAL AERONAUTICS AND SPACE ADMINISTRATION  
GEORGE C. MARSHALL SPACE FLIGHT CENTER  
MARSHALL SPACE FLIGHT CENTER, ALABAMA 35812**

**Contract No.** NAS8-30490

**DR. No.** *5-3*

**WBS.No.** *4B681-04-01*

***Thiokol* CORPORATION**  
**SPACE OPERATIONS**

*P.O. Box 707, Brigham City, UT 84302-0707 (801) 863-3511*

(NASA-CR-183904) FLIGHT SET 360H005  
(STS-28) SEALS, VOLUME 4 Final Report  
(Thiokol Corp.) 141 p

CSCL 11A

N90-28051

unclas

63/37 027481b

DOC NO.  
TITLE

VOL REV

TWR-17544

Flight Set 360H005 (STS-28)  
SEALS FINAL REPORT  
Volume IV

February 1990

Prepared by:

Jeffery T. Curry 2/12/90  
J. T. Curry  
Joints and Seals Design

Approved by:

Jerry Burn  
J. Burn, Supervisor  
Joints and Seals Design

Jay V. Daines  
J. V. Daines, Manager  
Metallic Component Design

R. B. Crosbie  
R. B. Crosbie  
Seals Program Management

Bon Lauer 2-27-90  
System Safety

Fred Quisenberry Jr 21 Feb 90  
Reliability

Released by:

P.C. Lydeck 2-27-90  
Data Management  
ECS No. 1013

**Thiokol** CORPORATION  
SPACE OPERATIONS

P.O. Box 707, Brigham City, UT 84302-0707 (801) 863-3511

**CONTENTS**

1.0	INTRODUCTION .....	1
2.0	SUMMARY AND CONCLUSIONS .....	12
2.1	Post-Flight Inspection Summary .....	12
3.0	O-RING SQUEEZE AND LEAK CHECK RESULTS .....	14
4.0	STRUCTURAL ASSESSMENT.....	14
5.0	POST-FLIGHT INSPECTION RESULTS .....	14
5.1	Left Motor "A" Disassembly Evaluation .....	17
5.1.1	External Walk Around .....	17
5.1.2	Safe and Arm Joint .....	17
5.1.3	Outer Igniter Joint .....	19
5.1.4	Inner Igniter Joint .....	19
5.1.5	Forward Field Joint .....	20
5.1.6	Center Field Joint .....	20
5.1.7	Aft Field Joint .....	21
5.1.8	Nozzle-to-Case Joint .....	21
5.1.9	Aft Exit Cone Joint .....	22
5.1.10	Forward End Ring-to-Nose Inlet Housing .....	23
5.1.11	Inlet Housing-to-Throat Support Housing .....	23
5.1.12	Forward Exit Cone-to-Throat Support Housing .....	24
5.1.13	Fixed Housing-to-Aft End Ring .....	24
5.1.14	Factory Joints .....	24
5.1.14.1	Forward Dome-to-Cylinder Factory Joint .....	25
5.1.14.2	Forward Cylinder-to-Cylinder Factory Joint .....	25
5.1.14.3	Center Forward Cylinder-to-Cylinder Factory Joint .....	26
5.1.14.4	Center Aft Cylinder-to-Cylinder Factory Joint .....	26
5.1.14.5	ET-to-Stiffener Factory Joint .....	27
5.1.14.6	Stiffener-to-Stiffener Factory Joint .....	27
5.1.14.7	Aft Dome-to-Stiffener Factory Joint .....	28
5.2	Right Motor "B" Disassembly Evaluation .....	29
5.2.1	External Walk Around .....	29
5.2.2	Safe and Arm Joint .....	29
5.2.3	Outer Igniter Joint .....	31
5.2.4	Inner Igniter Joint .....	31
5.2.5	Forward Field Joint .....	32
5.2.6	Center Field Joint .....	33
5.2.7	Aft Field Joint .....	34
5.2.8	Nozzle-to-Case Joint .....	34
5.2.9	Aft Exit Cone Joint .....	35
5.2.10	Forward End Ring-to-Nose Inlet Housing .....	36
5.2.11	Inlet Housing-to-Throat Support Housing .....	36
5.2.12	Forward Exit Cone-to-Throat Support Housing .....	37
5.2.13	Fixed Housing-to-Aft End Ring .....	37

**CONTENTS (Continued)**

5.2.14	Factory Joints .....	38
5.2.14.1	Forward Dome-to-Cylinder Factory Joint .....	38
5.2.14.2	Forward Cylinder-to-Cylinder Factory Joint .....	38
5.2.14.3	Center Forward Cylinder-to-Cylinder Factory Joint .	39
5.2.14.4	Center Aft Cylinder-to-Cylinder Factory Joint .....	39
5.2.14.5	ET-to-Stiffener Factory Joint .....	40
5.2.14.6	Stiffener-to-Stiffener Factory Joint .....	40
5.2.14.7	Aft Dome-to-Stiffener Factory Joint .....	41
5.3	Leak Check and Vent Port Plug Post-Flight Evaluations .....	41
5.4	Post-Fire Team Assessments .....	49
5.4.1	Remains Observation .....	49
5.4.2	Minor Anomalies .....	50
5.4.3	Major Anomalies .....	50
5.4.4	Critical Anomalies .....	51
5.5	RPRB Position .....	51
6.0	REFERENCES .....	53

**FIGURES**

Figure 1	RSRM Motor Configuration .....	2
Figure 2	RSRM Assembled Field Joint .....	3
Figure 3	Nozzle-to-Case Joint .....	4
Figure 4	Igniter Cross Section .....	5
Figure 5	Ignition System Seals .....	6
Figure 6	Forward Exit Cone-to-Aft Exit Cone Joint .....	7
Figure 7	Nose Inlet Housing-to-Flex Bearing Joint .....	8
Figure 8	Nose Inlet-to-Throat Housing Joint .....	9
Figure 9	Throat-to-Forward Exit Cone Joint .....	10
Figure 10	Flex Bearing-to-Fixed Housing Joint .....	11
Figure 11	Indentation on Right Hand Inner Igniter Gasket .....	13

**CONTENTS (Continued)**

**TABLES**

Table 1 360H005 Leak Check and Vent Port Plug Inspection ..... 44  
Table 2 Criteria for Classifying "Potential Anomalies" ..... 52

**APPENDICES**

Appendix A RPRB Presentations ..... A-1

## 1.0 INTRODUCTION

This report assesses the performance of the 360H005, Fifth Flight, Redesign Solid Rocket Motors (RSRM) in respect to joint sealing issues as seen from post-flight inspection of the seals and sealing surfaces. The factory joint disassembly inspections have resumed for 360H005. The new factory joint grease application is in effect and now can be assessed during the disassembly process.

Figure 1 illustrates the RSRM consisting of capture feature field joints with the J-joint insulation configuration (see Figure 2). Figure 3 illustrates the nozzle-to-case joint design, which includes 100, 7/8-inch radial bolts in conjunction with a wiper O-ring and modified insulation design.

The ignition system seals and a cross section of the igniter are illustrated in Figures 4 and 5. Figures 6 through 10 show the configuration of all the internal nozzle joints.

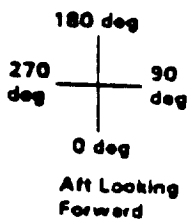
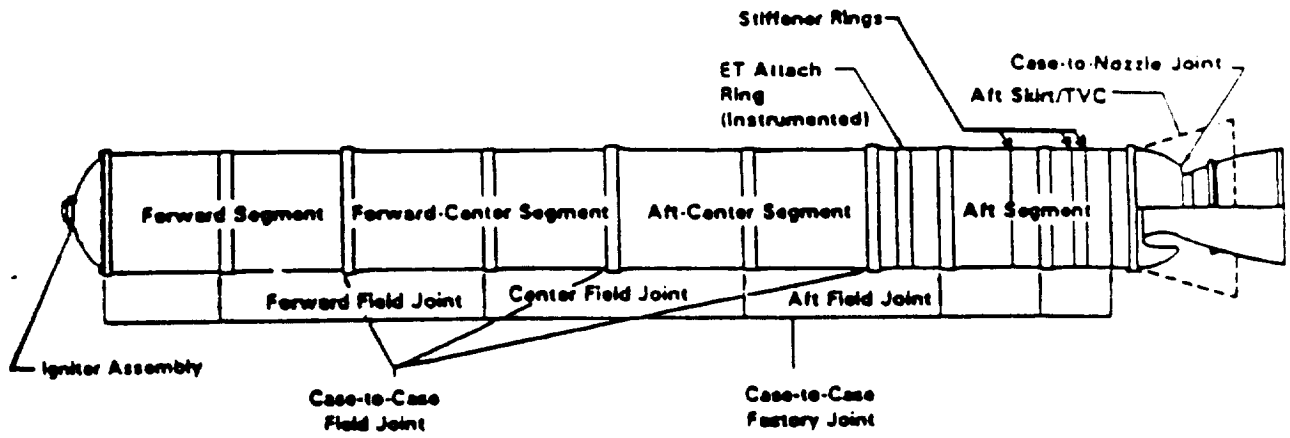

Figure 1  
RSRM Motor Configuration

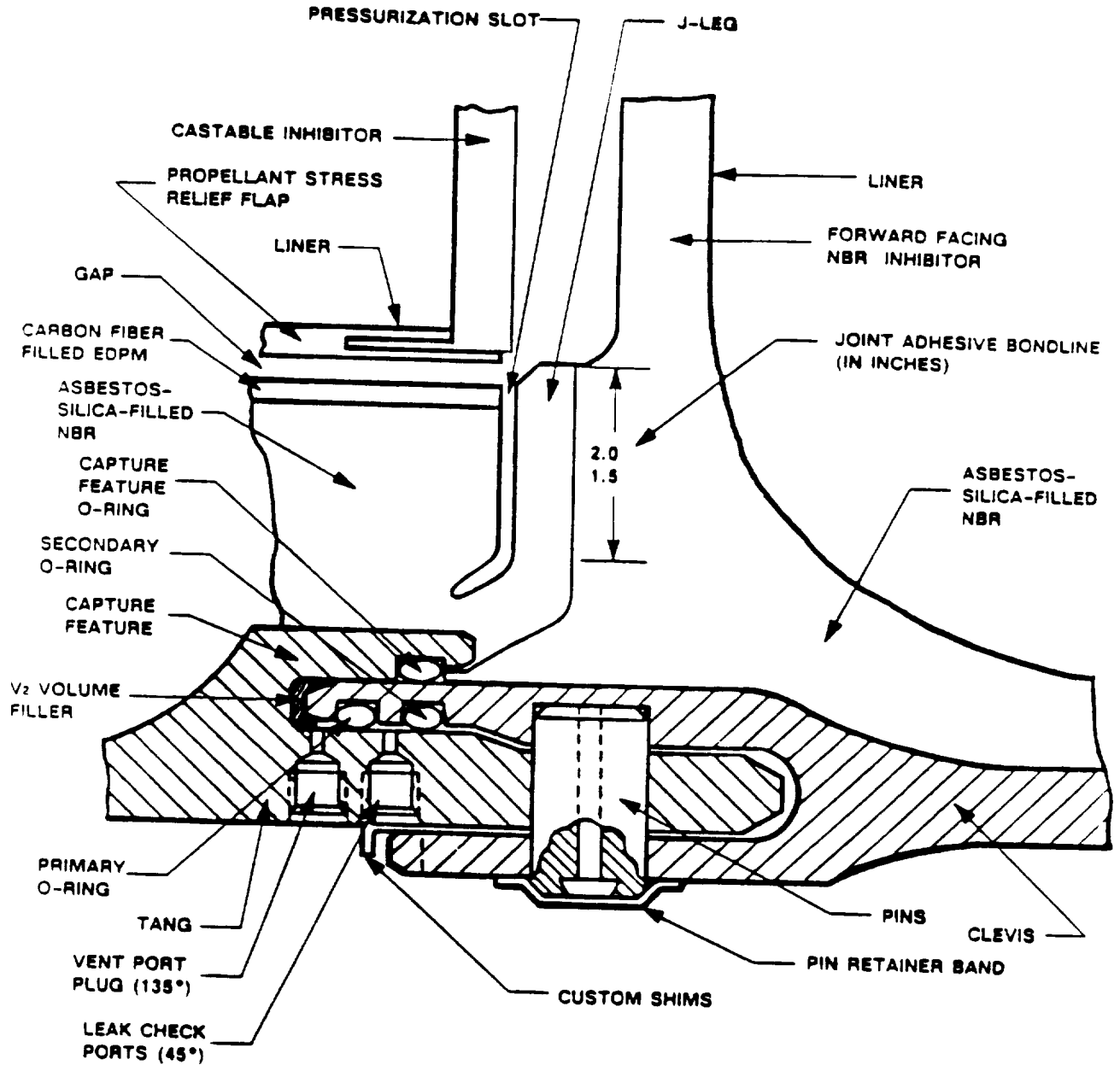

Figure 2  
RSRM Assembled Field Joint



fig 3

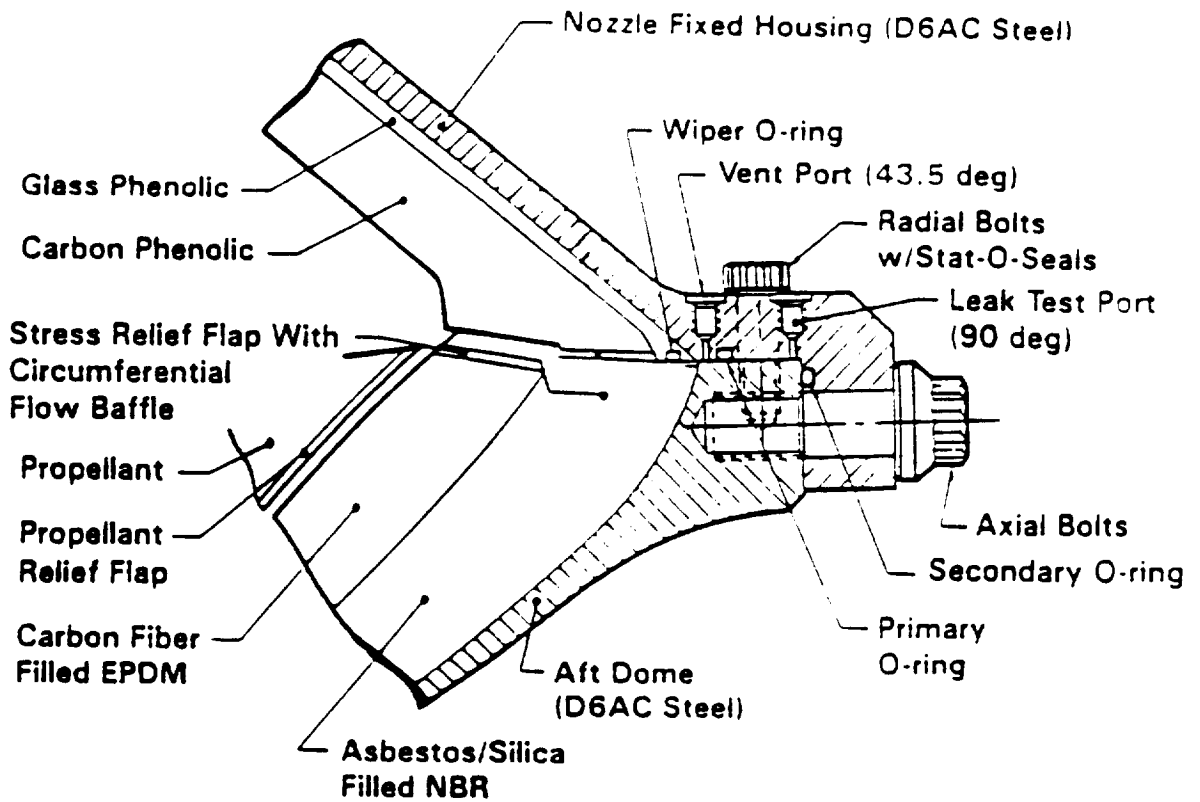

Figure 3  
Nozzle-to-Case Joint

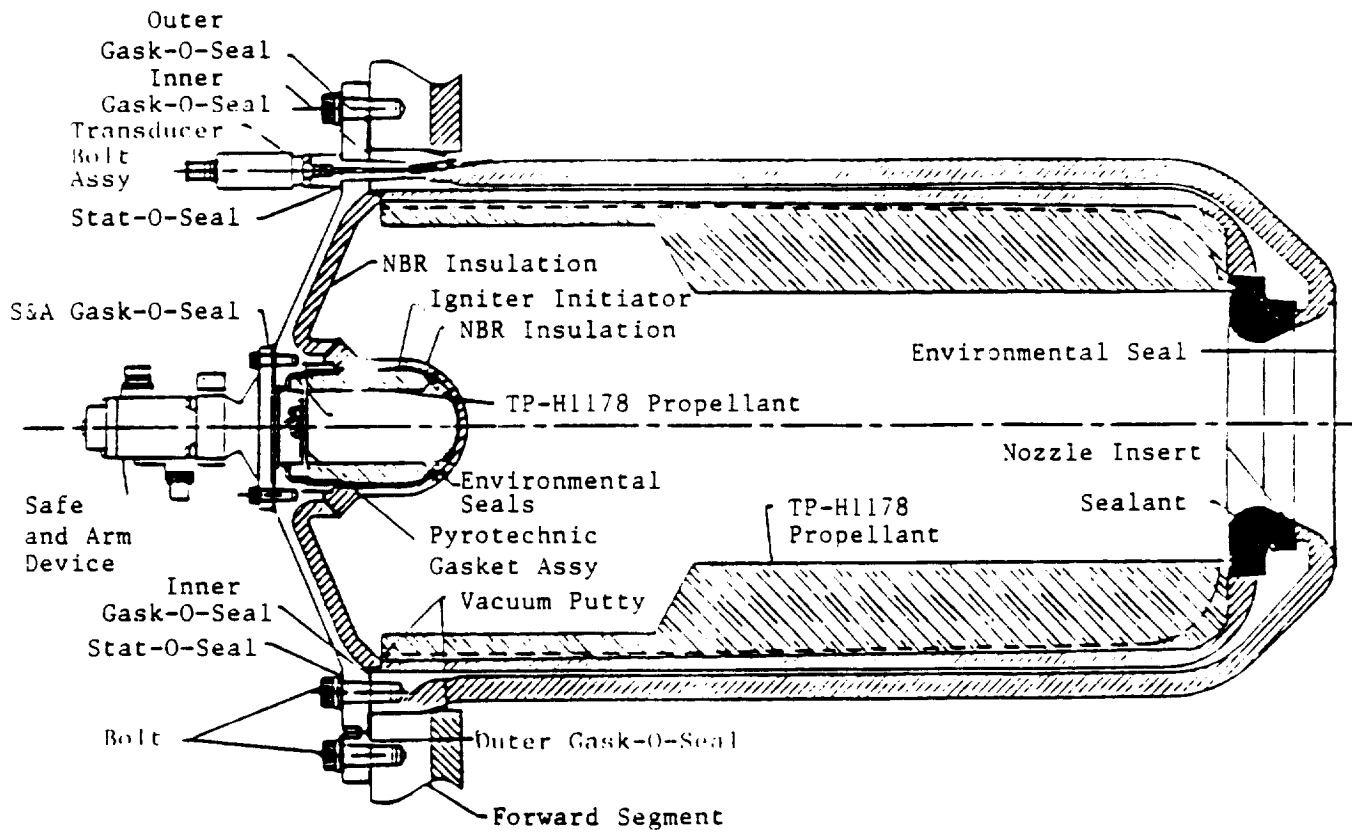
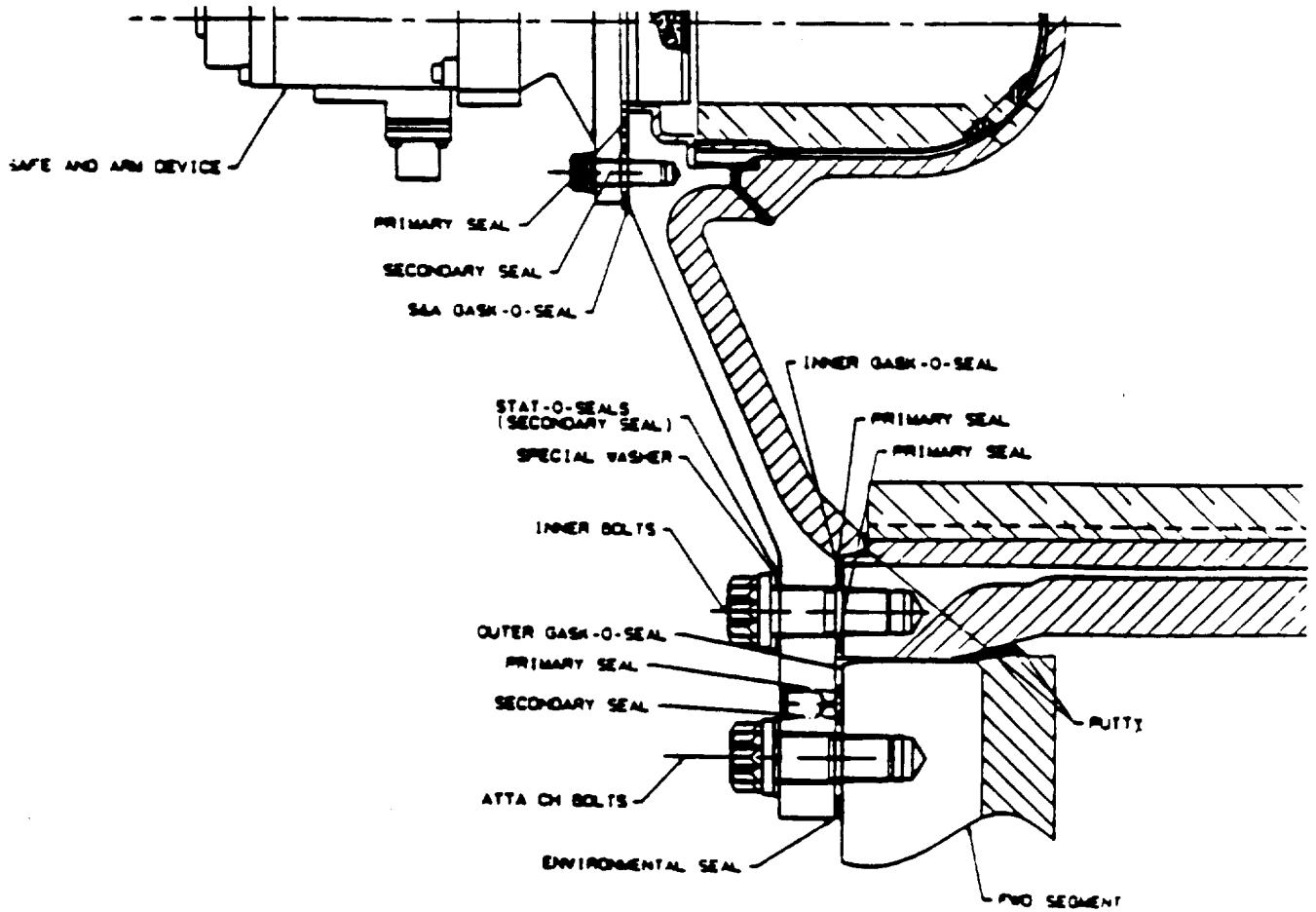

Figure 4  
Igniter Cross Section



ORIGINAL PAGE IS  
OF POOR QUALITY

Figure 5  
Ignition System Seals

REVISION \_\_\_\_\_

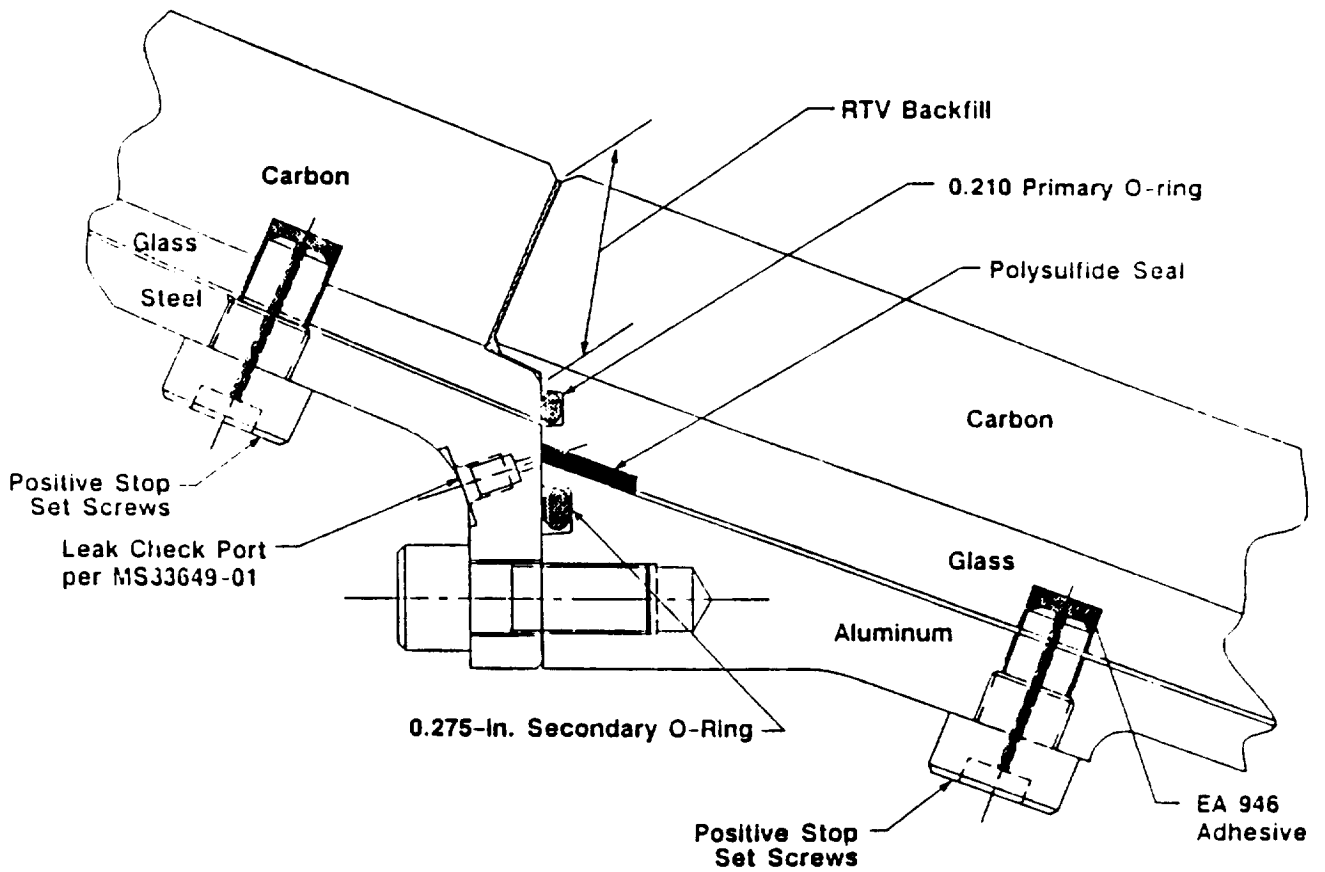

Figure 6  
Forward Exit Cone-to-Aft Exit Cone Joint

REVISION \_\_\_\_\_

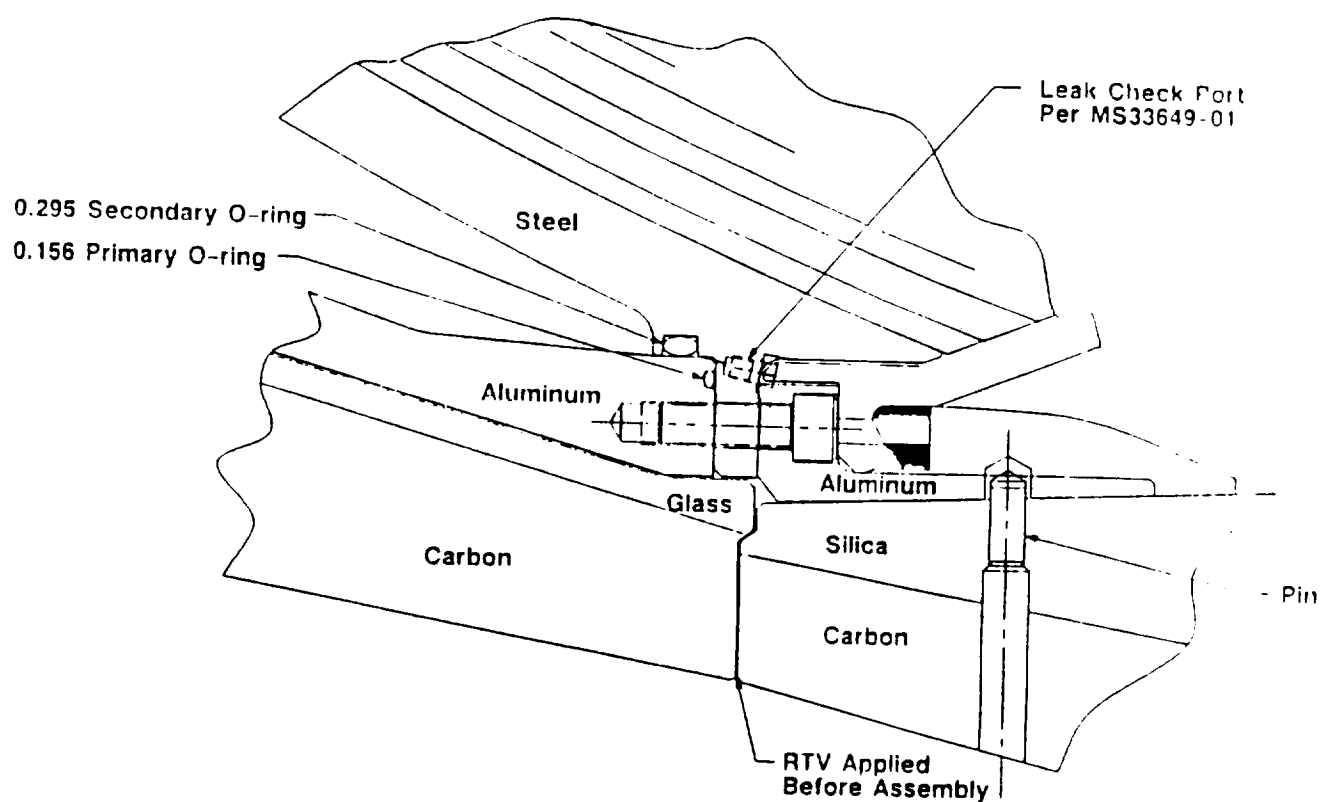

Figure 7  
Nose Inlet Housing-to-Throat Support Housing Joint

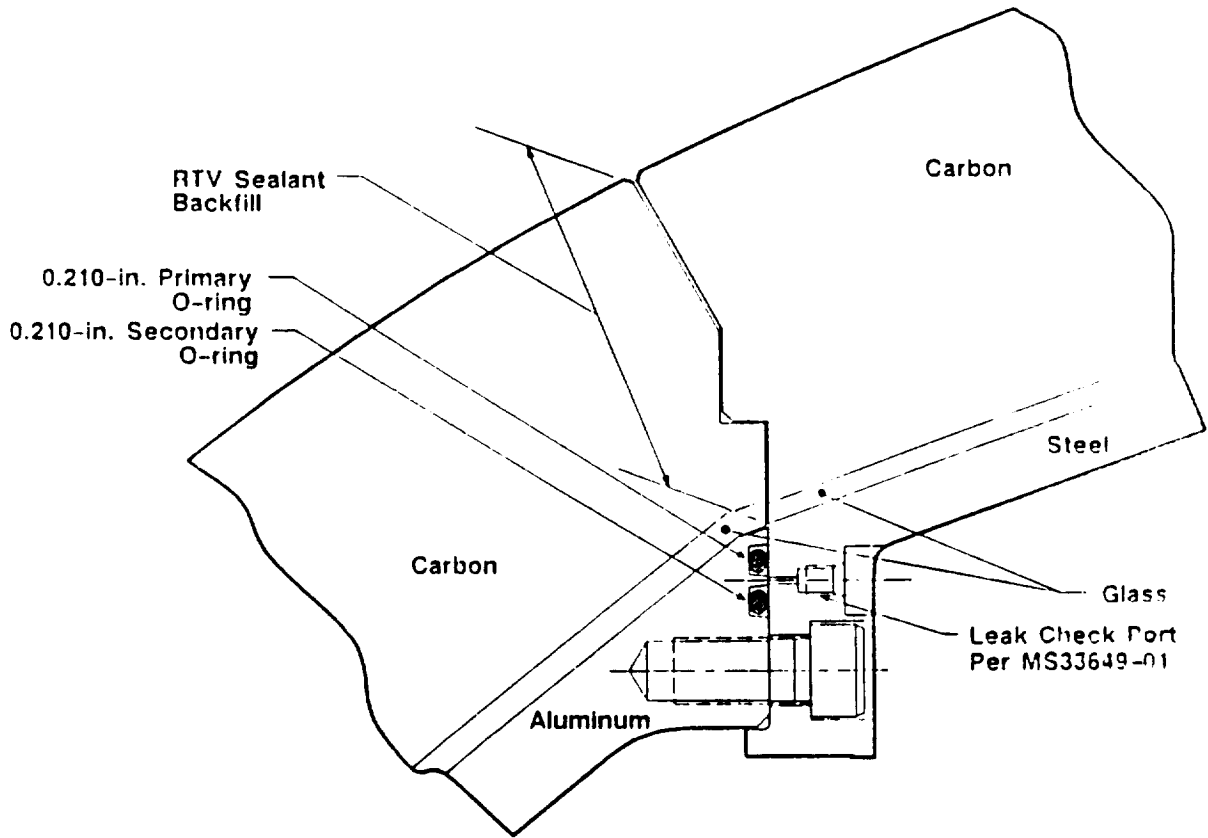

Figure 8  
Nose Inlet Housing-to-Throat Support Housing Joint

REVISION \_\_\_\_\_

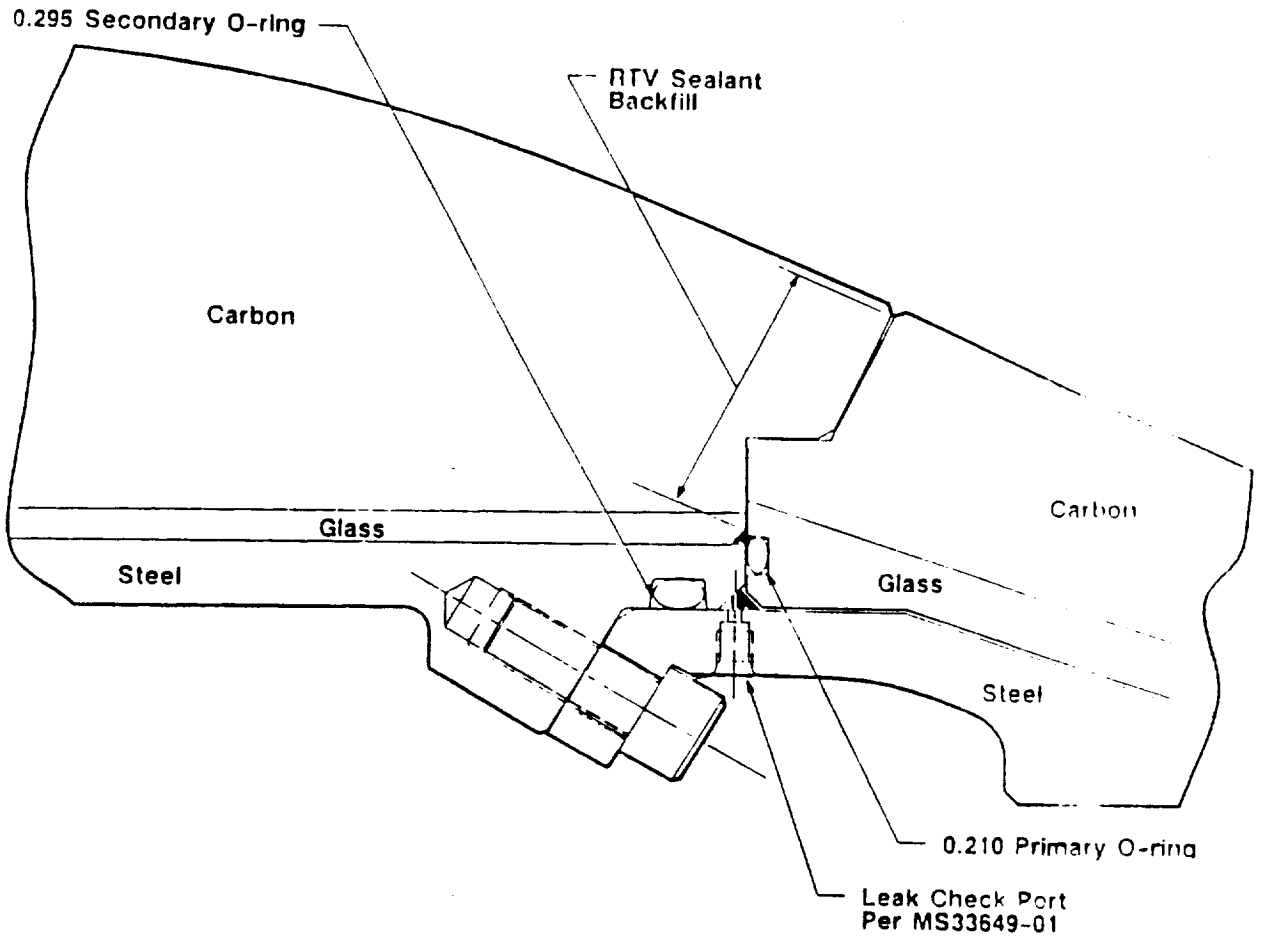

Figure 9  
Throat Support Housing-to-Forward Exit Cone Joint

REVISION \_\_\_\_\_

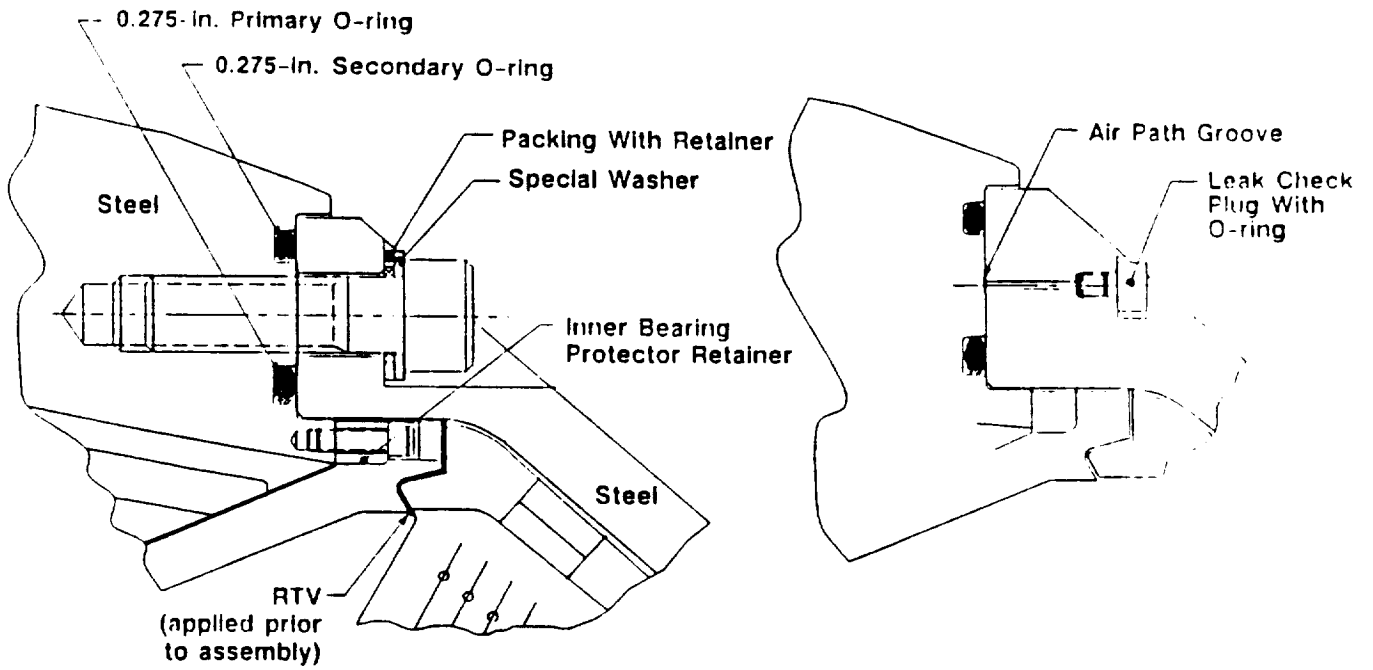

Figure 10  
Aft End Ring-to-Fixed Housing Joint

REVISION \_\_\_\_\_



## 2.0 SUMMARY

### 2.1 Post-Flight Inspection Summary

The post-flight inspection of both motors showed the seal components to be in excellent condition except for the indentation found on the inner primary seal of the right hand inner igniter gasket, aft face (see Figure 11). Detailed inspection results, and inspections performed by the O-ring Inspection Team can be found in Section 5.0 of this report.

The Component Program Teams (CPT) have identified twelve observations, made during disassembly inspections, as "potential anomalies." The twelve potential anomalies were further classified as two remains observations, nine minor anomalies, and one major anomaly. These classifications are further discussed in Section 5.4.

There was no evidence of hot gas or soot past the J-seal on the six field joints or past the polysulfide on the two nozzle-to-case joints. The igniter joints showed no hot gas or soot past the primary seals. There was no soot to the aft exit cone primaries and there was no evidence of soot or hot gas past the primary seals on any of the internal nozzle joints.

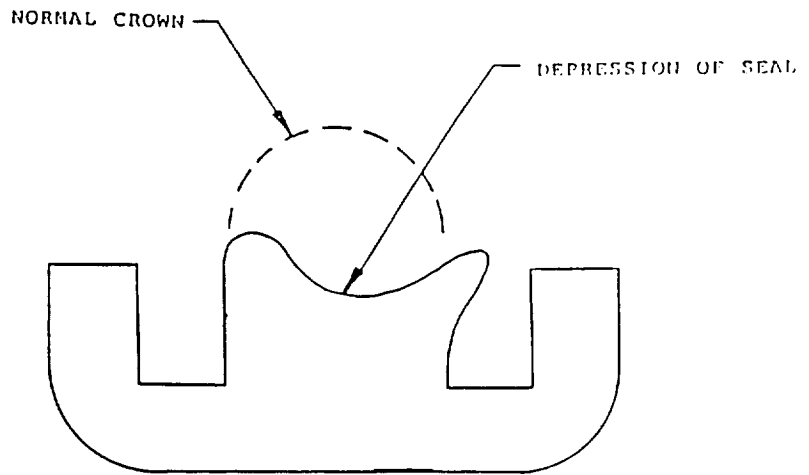
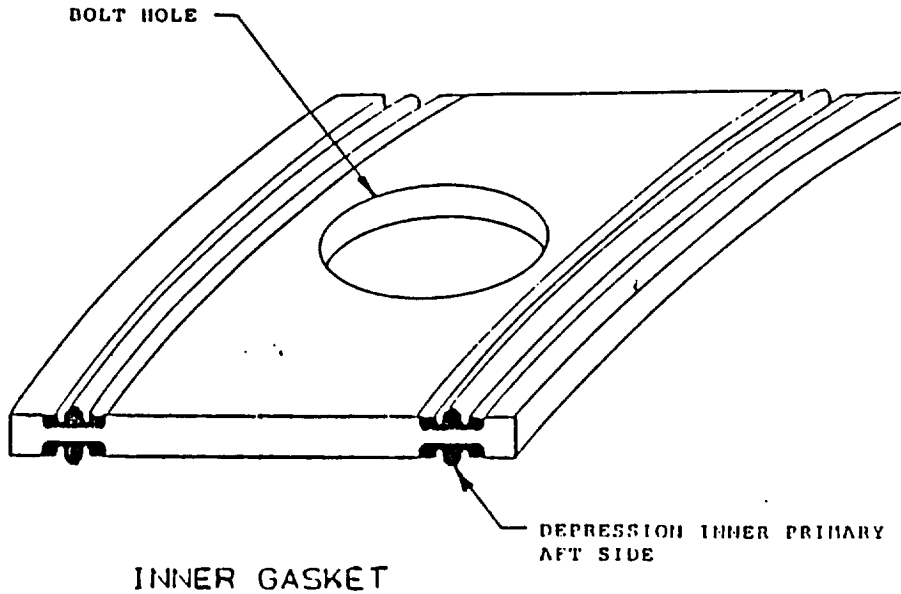

PRIMARY SEAL - CROSS SECTION

Figure 11  
Indentation on Right Hand Inner Igniter Gasket

There was light surface corrosion on the outer clevis leg on all the field joints, no corrosion was found on any sealing surfaces. Intermittent aluminum corrosion ( $Al_2O_3$ ) was found between the primary and secondary seals on the right aft exit cone joint. Overall the grease application to all field and nozzle-to-case joints was nominal.

### 3.0 O-RING SQUEEZE AND LEAK CHECK RESULTS

Calculations for the 360H005 O-ring squeeze are given in TWR-18761 (see Reference 1). The results of the leak check of the 360H005 boosters are addressed in detail in TWR-18798 (see Reference 2).

### 4.0 STRUCTURAL ASSESSMENT

This section normally details the structural assessment of the case field joints, factory joints, nozzle-to-case joint, and case metal components with comparisons to the flight envelopes and previous flights. However, there was no Development Flight Instrumentation (DFI) installed on this flight set, therefore, no structural assessment is made in this report.

### 5.0 POST-FLIGHT INSPECTION RESULTS

Joints and Seals Design Engineering performed a post-flight evaluation of the 360H005 forward, center, and aft field joints, aft exit cone field

joints, nozzle-to-case joints, the igniter, and safe and arm joints at Hangar A-F, Kennedy Space Center (KSC), Florida. The internal nozzles, S&As, and factory joints were disassembled and inspected at the H-5 and H-7 refurbishment facility in Clearfield, Utah. The objective of this section is to document the post-flight condition of the 360H005 plugs, sealing surfaces and seals as noted during disassembly, and to discuss all observations assessed by the Seal Component Team.

In an attempt to standardize and document the evaluation of flight motors, a standard evaluation plan has been written (see References 3 and 4). Appropriate procedures contained in this plan were used to evaluate the sealing system of all joints contained in the RSRM. The intent of this plan is to ensure that all pertinent evaluation points of 360H005 are examined and documented in a consistent and complete manner.

The left motor will be discussed first, then the right motor. The evaluation will start at the igniter and proceed down the motors to the aft exit cones. The following guidelines have been established to classify O-ring, gasket, Stat-O-Seal and corrosion damage found from post-flight/test inspections. These guidelines were established so that each inspection data base will be consistent and not be confusing or misleading. Some of these definitions are used in this document.

#### O-RINGS , GASKETS AND STAT-O-SEALS

Cut: Width, essentially zero (have to open up to find the damage), and depth greater than 0.005 inch.

<u>Scratch:</u>	Width less than 0.005 inch and depth less than 0.005 inch.
<u>Nick:</u>	Width less than 0.020 inch, but greater than 0.005 inch; and depth less than 0.010 inch, but greater than 0.005 inch.
<u>Gouge:</u>	Width greater than 0.020 inch and depth greater than 0.010 inch.
<u>Circumferential or Radial Flowline:</u>	Visible evidence of incomplete flow or knit of the material.
(i) Closed:	Tightly adhered, not separable, does not open when lightly probed.
(ii) Separable:	Visually appears closed. Separates when lightly probed.
(iii) Open:	Obvious separation or gap.
<u>Hard Inclusion:</u>	Foreign material enclosed in the seal material.
<u>Porosity/Soft Inclusion:</u>	An air pocket enclosed in the seal material.
<u>Extrusion Damage:</u>	Seal material pinched and/or cut due to an overfill condition.
<u>Heat Effect:</u>	Glossy and/or hardened seal surface due to hot gas impingement.
<u>Erosion:</u>	Seal material missing due to hot gas impingement or blow by.

**CORROSION**

<u>Light Corrosion:</u>	can be wiped off by hand. Surface discoloration.
<u>Medium Corrosion:</u>	Can not be wiped off by hand without the use of a Scotch-Brite material, methyl chloroform, or grease soaked rag.

Heavy Corrosion: Starting to penetrate into the metal surface such that pitting and/or metal material is significantly eroded.

## 5.1 Left Motor Disassembly Evaluation

There were no critical observations found on the left motor.

### 5.1.1 External Walk Around

The external walk around inspection revealed no signs of hot gas leakage past any joints.

### 5.1.2 Safe and Arm Joint

Soot was observed on the inboard edge of the gasket the full circumference. There was no soot to the primary seal. Moisture was found inboard of the primary seal on the igniter adapter S&A boss. No corrosion was noted. Inspection of the gasket at disassembly revealed no damage. Detailed inspection of the gasket by the O-ring inspection team also revealed no damage.

Detailed inspection of the S&A upon disassembly revealed the primary and secondary O-rings of the rotor shaft were in good condition, with no

evidence of blow-by or heat effects found. The secondary O-rings were also in good condition with no evidence of damage found.

Inspection of the barrier booster (B-B) rotor shaft housing bore revealed one circumferential and two axial scratches that could be felt using a 5 and 10 mil piece of brass shim stock. The scratches were on the primary and secondary sealing surface similar in footprint to those found on Fourth Flight. It was determined that these scratches were caused by the bore micrometer used to measure the bore diameters prior to assembly.

Inspection of the S&A to Adapter leak check port plug (306 degrees) revealed lint contamination underneath the O-ring. The contamination was probably introduced at assembly. Grease application appeared to be slightly heavy on the B-B rotor leak check plug (126 degrees).

The initiators were removed from the B-B and inspected. No evidence of blow-by was found past the threads. The primary sealing surface of each initiator was inspected for threads protruding into the sealing region. None were noted. One small deformation was noted on each of the sealing washers of the two initiators. This washer forms the sealing surface of the secondary O-ring.

### 5.1.3 Outer Igniter Joint (Adapter-to-Forward Dome)

A blow path through the zinc chromate putty was present at 105 degrees. The jet was approximately 0.35 inch wide through the entire length. Soot was noted to the primary seal on the forward face from 130 to 140 degrees. Heavy soot was observed from 100 to 140 degrees on the forward face of the metal retainer. No soot was present past the primary seal and no heat affect was indicated on the gasket.

Light corrosion was found on the inner edge of the gasket intermittently the entire circumference and most notably at the blowhole location.

### 5.1.4 Inner Igniter Joint (Adapter-to-Chamber)

No soot or damage was observed on the gasket seals. No corrosion was found on the gasket or joint metal surface. All stat-o-seals from the inner joint bolts had typical disassembly damage.

There was heavy soot on the end of special bolts, and light soot to the primary seal of the special bolt removed from 100 degrees.

Inspection of the OPTs (operational pressure transducers) located at 40, 180, and 270 degrees showed soot deposits up to but not past the primary



seals. Inspection of the special bolt and IPT plugs located at 100 and 115 degrees respectively showed soot deposits up to but not past the primary seals. No anomalous conditions were noted on the seals or plugs.

#### 5.1.5 Forward Field Joint

There was no sign of hot gas or soot past the J-leg. The grease coverage was per design and no corrosion was found on any sealing surface. The outer diameter of the outer clevis leg showed intermittent light surface corrosion from zero to 360 degrees on the one inch unpainted surface. The joint was heavily contaminated with debris from hydrolaze operations, which is used to remove the joint protection system.

No seal damage was observed at the time of disassembly, and the V2 filler was properly installed with no visible damage. Detailed inspection of the large diameter O-rings revealed no damage to primary or secondary. Two very light circumferential scratches were found on the capture feature O-ring at 290.4 and 306.1 degrees. The worst case scratch at 306.1 degrees measured 12.5 inches long, 0.001 inch wide and an indeterminable depth.

#### 5.1.6 Center Field Joint

There was no sign of hot gas or soot past the J-leg. The grease coverage was per design and no corrosion was found on any sealing surface. No

corrosion was found on any of the joint interior surfaces. The outside diameter of the outer clevis leg showed light intermittent corrosion from zero to 360 degrees on the one inch unpainted surface. The joint was contaminated with debris from hydrolaze operations. No seal damage was observed on the primary or secondary O-rings at the time of disassembly. The V2 filler was properly installed and no visible damage was found. Detailed inspection of the large diameter O-rings revealed no damages.

#### 5.1.7 Aft Field Joint

There was no sign of hot gas or soot past the J-joint. The grease coverage was per design and no corrosion was found on any sealing surfaces. The outside diameter of the outer clevis leg showed light intermittent corrosion from zero to 360 degrees on the one inch unpainted surface. The joint was contaminated with debris and water from hydrolaze operations. No seal damage was observed at the time of disassembly and the V2 filler was properly installed with no visible damage. Detailed evaluation of the large diameter O-rings by the O-ring inspection team revealed no damages.

#### 5.1.8 Nozzle-to-Case Joint

There was no evidence of hot gas or soot past the polysulfide. The grease application was per specification. There was no corrosion found on either the fixed housing or the aft dome. No polysulfide extruded past the wiper

O-ring. A small amount of Teflon tape residue was observed intermittently at the metal to glass interface on the fixed housing. No radial bolt hole disassembly plugs were damaged during the disassembly process.

There were no signs of O-ring damage at the time of disassembly on the primary, secondary, or wiper O-rings. Detailed inspection of the O-rings found no damage on the primary O-ring or secondary O-ring. The wiper O-ring had one light circumferential scratch that measured 4.0 inches in length and 0.001 inch in width with an indeterminable depth. Inspection of the Stat-O-Seals found four Stat-O-Seals with torn seals.

#### 5.1.9 Aft Exit Cone Joint (Joint 1)

No pressure paths were found through the RTV, so no pressure or soot reached the primary O-ring. Light oxidation/corrosion was found between the the O-ring foot prints on the forward and aft exit cone intermittently around. Both O-rings fell out of the groove at disassembly so no in-groove inspection was done. Detailed inspection by the O-ring inspection team revealed two gouges (207.7 and 227.4 degrees) and two scratches (287 and 349.3 degrees) on the primary O-ring. The worst case being the gouge at 227.4 degrees. The gouge measured 0.25 inch long, 0.02 inch width and 0.01 inch deep. The secondary O-ring sustained seven gouges at 127.8, 151.3, 201.1, 220.8, 257.8, 307.3 and 342.2 degrees. The worst case being the gouge at 342.2 degrees. The gouge measured 0.25 inch long, 0.04 inch width

and 0.02 inch deep. The cause of the gouges and nicks are suspected to have been caused by the O-rings falling out at disassembly and the O-ring clips, which are used to hold the O-rings in place during disassembly.

#### 5.1.10 Forward End Ring-To-Nose Inlet Housing (Joint 2)

Inspection of the joint did not reveal any obvious pressure paths through the RTV/adhesive of the joint interface. Soot reached the primary O-ring at 282 to 342 degrees. Sooting was also noted at the metal interface the entire circumference with the heaviest sooting between 324 and 346 degrees. No soot or evidence of blow-by was present past the primary O-ring. No apparent damage to the primary or secondary O-rings was found during the in groove inspection, and the sealing surfaces suffered no assembly or disassembly damage. Detailed inspection of the large diameter O-rings by the O-ring inspection team revealed no damages.

#### 5.1.11 Nose Inlet Housing-To-Throat Support Housing (Joint 3)

Detailed inspection revealed no anomalies to the joint. Inspection of the sealing surfaces revealed no signs of damage. No apparent damage was found during preliminary inspection of the primary and secondary O-rings. Detailed inspection of the large diameter O-rings by the O-ring inspection team also showed no damage occurred to the O-rings.

#### 5.1.12 Forward Exit Cone-To-Throat Support Housing (Joint 4)

Inspection of the joint at disassembly revealed no pressure paths through the RTV backfill. Light intermittent corrosion was noted around the circumference of the bondline to metal interface on both components. No apparent damage to the primary and secondary O-rings was found during preliminary inspection, and the sealing surfaces suffered no assembly/disassembly damage. Detailed inspection of the large diameter O-rings by the O-ring inspection team revealed no anomalies.

#### 5.1.13 Fixed Housing-To-Aft End Ring (Joint 5)

Detailed inspection of the joint revealed some medium corrosion between 195 and 290 degrees outboard of the secondary seal on the aft end ring. Inspection of the sealing surfaces revealed no signs of damage. No damage was found during preliminary inspection of the primary and secondary O-rings. Detailed inspection of the large diameter O-rings by the O-ring inspection team revealed no damages. Inspection of all the Stat-O-Seals showed typical disassembly damage.

#### 5.1.14 Factory Joints

Design Engineering resumed inspection of factory joints on Fifth Flight components. Because of schedule problems with the case hardware and a

sufficient database on factory joints, the post-flight inspection was discontinued until Fifth Flight. Inspection has resumed on Fifth Flight to evaluate the new grease application techniques incorporated on Fifth Flight factory joints.

5.1.14.1 **Forward Dome-to-Cylinder Factory Joint.** No anomalies were reported from the on sight inspection of this joint. No corrosion was observed on the outer clevis leg or internal joint. Overall grease application was nominal in respect to the incorporated application technique. Insulation and Chemlok were found on the land forward of the primary O-ring groove 80 percent around the circumference of the joint.

Inspection of the large diameter O-rings found a 0.50 inch long scratch at 277 degrees on the primary O-ring. The scratch was 0.003 inch wide by 0.001 inch deep.

5.1.14.2 **Forward Cylinder-to-Cylinder Factory Joint.** No anomalies were reported from the on sight inspection of this joint. No corrosion was observed on the outer clevis leg or internal joint. Overall grease application was nominal in respect to the incorporated application technique. Insulation and Chemlok were found on the land forward of the primary O-ring groove 90 percent around the circumference of the joint.

Inspection of the large diameter O-rings found no damage on the primary or secondary O-rings.

5.1.14.3 **Center Forward Cylinder-to-Cylinder Factory Joint.** The outer clevis leg tip had light to medium corrosion 60 percent of the full circumference. No corrosion was observed in the internal joint areas. The overall grease application was light. Insulation and Chemlok were found on the land forward of the primary O-ring groove 30 percent around the circumference of the joint.

Small pits were observed on the land between the O-ring grooves at 202, 204, 206 and 324 degrees. Similar pits were observed on the associated tang sealing surface at 154, 156, 158, 161, 164-170, 173-180, 202, 204, 206, 219, 235-337, 324 and 328 degrees. No corrosion was noted with these pits. Pits in the same degree location on interfacing hardware gives an indication of fretting.

Inspection of the large diameter O-rings found no damage on the primary or secondary O-rings.

5.1.14.4 **Center Aft Cylinder-to-Cylinder Factory Joint.** No corrosion was observed on the outer clevis leg or internal joint. Overall grease application was light with intermittent areas of nominal coverage in respect to the incorporated application technique. Heavier than normal insulation and Chemlok were found on the land forward of the primary O-ring groove 60 percent around the circumference of the joint.

Fretting was observed on the land between the O-ring grooves and on the associated mating surface on the tang at 190, 194, 202, 330, and 350 degrees.

Inspection of the large diameter O-rings found no damage on the primary or secondary O-rings.

**5.1.14.5 ETA-to-Stiffener Factory Joint.** During disassembly operations, the water knife (tool used to remove insulation) cut through the primary O-ring at 115 degrees. Water knife damage was indicated from 88 to 138 degrees on the primary O-ring. This caused debris and moisture to contaminate the internal joint region. Fluid was noted in the port due to the water knife. Light corrosion was noted on the land forward of the primary O-ring at 106 degrees. The overall grease coverage was nominal. Insulation and Chemlok were found on the land forward of the primary O-ring groove 30 percent around the circumference of the joint.

A diagonal scratch was noted on the secondary O-ring at 340 degrees. The scratch measured 0.15 inch long, 0.002 inch wide and 0.001 inch deep.

**5.1.14.6 Stiffener-to-Stiffener Factory Joint.** No corrosion was observed on the outer clevis leg or internal joint. Overall grease application was nominal in respect to the incorporated application technique. Insulation



and Chemlok were found on the land forward of the primary O-ring groove 30 percent around the circumference of the joint.

Light scratches were noted intermittently the full circumference on the land forward of the primary O-ring groove. Light scratches and burnishes were also noted intermittently the full circumference on the chamfer of the tang indicating an interference fit during assembly.

Inspection of the large diameter O-rings found no damage on the primary or secondary O-rings.

**5.1.14.7 Aft Dome-to-Stiffener Factory Joint.** The outer clevis leg tip had light to medium corrosion 90 percent of the full circumference. No corrosion was observed in the internal joint areas. The overall grease application was light. Insulation and Chemlok were found on the land forward of the primary O-ring groove 70 percent around the circumference of the joint.

Fretting was observed on the land between the O-ring grooves and on the associated mating surface on the tang at 234, 236, 238, 242, 245-256, 264, 265, 282 and 286 degrees. Also, pits were observed on the tang downstream of the sealing surface at 22, 30 and 34 degrees. These pits were approximately 0.010 inch deep.

Inspection of the large diameter O-rings found scratches at 234 and 236 degrees on the primary O-ring. The scratches measured 0.20 inch long, 0.002 inch wide and 0.005 inch deep. The scratches were probably caused by the raised metal at the corresponding fretted locations.

## 5.2 Right Motor Disassembly Evaluation

There were no critical observations found on the right motor.

### 5.2.1 External Walk Around

The external walk around inspection revealed no signs of hot gas leakage past any joints.

### 5.2.2 Safe and Arm Joint (Adapter-to-Barrier Booster)

There was soot up to the primary seal on both sides of the S&A gasket. No soot was observed past the primary seals. Intermittent light corrosion was found on the inboard edge of the metal retainer of the gasket. No other damage was found to the joint or gasket seals at the time of disassembly. Detailed inspection of the gasket by the O-ring inspection team revealed no anomalous conditions.

Detailed inspection of the S&A upon disassembly revealed the primary and secondary O-rings of the rotor shaft were in good condition, with no evidence of blow-by or heat effects found. Some copper particles were found in the grease on the secondary O-rings. An investigation has determined the copper is from fittings in the vendor leak test equipment. Circumferential closed flow lines were noted on an environmental seal removed from the S&A. The largest measured 0.120 inch long.

Inspection of the barrier booster (B-B) rotor shaft housing bore revealed two axial scratches which could be felt using a 5 and 10 mil piece of brass shim stock. The scratches were found on the secondary seal surface. It was determined that these scratches were caused by the bore micrometer used at E-VAD (the vendor) to measure the bore diameters prior to assembly. The footprint of these scratches are similar to the ones found on Fourth Flight.

The B-B leak check port plug (126 degrees) had a metal burr on the tip of the plug below the lead thread. It was also noted that the grease application on this plug was slightly heavy. The S&A to adapter leak check plug (306 degrees) appeared to have no grease applied. A small void was found in the O.D. of the S&A leak test port plug. The void measured 0.05 inch long, 0.015 inch wide, and 0.003 inch deep.

The initiators were removed from the B-B and inspected. No evidence of

blow-by was found past the threads. The primary sealing surface of each initiator was inspected for threads protruding into the sealing region. None were found. One small deformation was noted on each of the sealing washers of the initiators. The deformation was probably caused by the removal tool. This washer forms the sealing surface of the secondary O-ring. Lint was also noted across the secondary O-ring of the initiator at 198 degrees.

### 5.2.3 Outer Igniter Joint (Adapter-to-Forward Dome)

A blow hole through the zinc chromate putty was observed at 270 degrees. The path measured from 2.0 inches to 0.38 inch at the exit. Two terminated blow holes were observed at 124 and 233 degrees. Heavy soot was noted on the inner retainer edge of the gasket 360 degrees. No soot reached the primary seal on either side of the gasket. Light corrosion was noted on the edge of the retainer at 270 degrees. Intermittent light corrosion was found on the edge of the forward dome boss and igniter adapter inboard of the primary sealing surface. No gasket seal damage was observed at the time of disassembly.

### 5.2.4 Inner Igniter Joint (Adapter-to-Chamber)

No blow holes were found in the zinc chromate putty on the inner igniter joint. Soot reached the outer primary seal on the aft face from the blow hole in the outer joint at 270 degrees. Medium corrosion was also noted on

the inner gasket outer retainer edge at 270 degrees. An indentation was observed in the crown of the inner primary seal at 220 degrees on the aft face. The indentation was approximately 0.10 inch long by 0.025 inch wide. The indentation slowly rebounded after disassembly. Dissection of the area revealed two small subsurface voids. Additional inspection criteria was implemented to find these type of voids prior to assembly in the joint. All stat-o-seals from the inner joint bolts were damaged during disassembly.

There was heavy soot on the end of special bolts, and light soot to the primary seals at 40, 100, 180, and 270 degrees.

Inspection of the OPTs (operational pressure transducers) located at 40, 180, and 270 degrees showed soot deposits up to the primary seals. Inspection of the special bolt and IPT plugs located at 100 and 115 degrees respectively, showed soot deposits up to the primary seals. No anomalous conditions were noted on the seals or plugs.

#### 5.2.5 Forward Field Joint

There was no sign of hot gas or soot past the J-leg. The grease coverage was per design and no corrosion was found on any sealing surface. Light intermittent corrosion spots were observed on the outside diameter of the tang, forward of the pin holes. The outside diameter of the outer clevis

leg showed intermittent light surface corrosion from zero to 360 degrees on the one inch unpainted surface. The joint was heavily contaminated with debris from hydrolaze operations, which is used to remove the joint protection system.

No seal damage was observed at the time of disassembly, and the V2 filler was properly installed with no visible damage. Detailed inspection of the large diameter O-rings revealed no damages.

#### 5.2.6 Center Field Joint

There was no sign of hot gas or soot past the J-leg. The grease coverage was per design and no corrosion was found on any sealing surface. No corrosion was found on any of the joint interior surfaces. The outside diameter of the outer clevis leg showed very light intermittent corrosion from zero to 360 degrees on the one inch unpainted surface. The joint was heavily contaminated with debris from hydrolaze operations. No seal damage was observed on the primary or secondary O-rings at the time of disassembly. The V2 filler was properly installed and no visible damage was found. Detailed inspection of the large diameter O-rings revealed a radial scratch at 249 degrees on the capture feature O-ring. The radial scratch measured 0.20 inch long, 0.005 inch wide and 0.005 inch deep.

### 5.2.7 Aft Field Joint

There was no sign of hot gas or soot past the J-leg. The grease coverage was per design and no corrosion was found on any sealing surface. Light intermittent pin hole and shim area corrosion was found on the inner surface of the outer clevis leg. The outside diameter of the outer clevis leg showed intermittent light surface corrosion from zero to 360 degrees on the one inch unpainted surface. Medium corrosion was also found on the tang bottom tip from 146 to 150 degrees. The joint was heavily contaminated with debris from hydrolaze operations.

No seal damage was observed at the time of disassembly, and the V2 filler was properly installed with no visible damage. Detailed inspection of the large diameter O-rings revealed no damages.

### 5.2.8 Nozzle-to-Case Joint

There was no evidence of hot gas or soot past the polysulfide. The grease application was per specification. There was no corrosion found on either the fixed housing or the aft dome. Polysulfide extruded past the wiper O-ring at 166 degrees but did not reach the primary O-ring. The radial bolt hole disassembly plug at 282.6 degrees was sheared off at disassembly.

There was no sign of O-ring damage at the time of disassembly on the primary, secondary or wiper O-rings. Detailed inspection of the large diameter O-rings by the O-ring inspection team revealed a circumferential scratch at 115.7 degrees and diagonal scratches at 129 degrees on the primary O-ring. The worst case scratch at 129 degrees measured 0.40 inch long, 0.002 inch wide and an indeterminable depth. The wiper O-ring had two nicks at 22.9 and 34 degrees. The worst case nick at 22.9 degrees measured 0.50 inch long, 0.02 inch wide and 0.01 inch deep. Inspection of the Stat-O-Seals revealed two torn seals.

#### 5.2.9 Aft Exit Cone Joint (Joint 1)

No pressure paths were found through the RTV, so no pressure or soot reached the primary O-ring. Light oxidation/corrosion was found between the the O-ring foot prints on the forward and aft exit cone intermittently around.

No damage to the primary or secondary O-rings was observed at the time of disassembly. Inspection of the large diameter O-rings conducted by the inspection team revealed several gouges and scratches between 112.2 and 133.5 degrees. The worst case gouge measured 0.40 inch long, 0.04 inch wide and 0.03 inch deep.



**5.2.10 Forward End Ring-To-Nose Inlet Housing (Joint 2)**

Inspection of the joint did not reveal any obvious pressure paths through the RTV/adhesive of the joint interface. Soot reached the primary O-ring at 18 to 38, 68 to 84, 162 to 176, 195, 207, 228 to 234, 250 to 258, 264 to 267, 270 to 281, 283 to 288 and 305 degrees. Sooting was found in the metal interface the entire circumference. No soot or evidence of blow-by was present past the primary O-ring.

No apparent damage to the primary or secondary O-rings was found on the in groove inspection, and the sealing surfaces suffered no assembly or disassembly damage. Detailed inspection of the large diameter O-rings by the O-ring inspection team revealed no damage.

**5.2.11 Nose Inlet Housing-To-Throat Support Housing (Joint 3)**

Detailed inspection revealed no anomalies to the joint. No apparent damage was found during preliminary inspection of the primary or secondary O-rings. Inspection of the sealing surfaces revealed no signs of damage. Detailed inspection of the large diameter O-rings by the O-ring inspection team revealed no damage.

**5.2.12 Forward Exit Cone-To-Throat Support Housing (Joint 4)**

Inspection of the joint revealed a pressure path through the RTV backfill between 235 and 263 degrees. Typical light corrosion was noted on the forward exit cone/throat bondline the full circumference. No apparent damage to the primary or secondary O-rings was found during preliminary inspection, and the sealing surfaces suffered no assembly/disassembly damage. Detailed inspection of the large diameter O-rings by the O-ring inspection team revealed no damage.

**5.2.13 Fixed Housing-To-Aft End Ring (Joint 5)**

Detailed inspection revealed medium corrosion outboard of the secondary O-ring on the aft end ring from 165 to 225 degrees. No damage was found during preliminary inspection of the primary or secondary O-rings. Inspection of the sealing surface revealed no signs of damage.

Detailed inspection of the large diameter O-rings by the O-ring inspection team noted a diagonal scratch at 70 degrees on the primary O-ring. The scratch measured 0.12 inch long, 0.002 inch wide and 0.002 inch deep. Inspection of all the Stat-O-Seals showed typical disassembly damage.

#### 5.2.14 Factory Joints

Design Engineering resumed inspection of factory joints on Fifth Flight components. Because of schedule problems with the case hardware and a sufficient database on factory joints the post-flight inspection was discontinued until Fifth Flight. Inspection has resumed on Fifth Flight to evaluate the new grease application techniques incorporated on Fifth Flight factory joints.

**5.2.14.1 Forward Dome-to-Cylinder Factory Joint.** No anomalies were reported from the on sight inspection of this joint. No corrosion was observed on the outer clevis leg or internal joint. Overall grease application was nominal in respect to the incorporated application technique. Small pits were noted on the land between the O-ring grooves. No corresponding pits on the tang were noted to indicate fretting. Insulation and Chemlok were found on the land forward of the primary O-ring groove 80 percent around the circumference of the joint.

Inspection of the large diameter O-rings found no damage on the primary or secondary O-rings.

**5.2.14.2 Forward Cylinder-to-Cylinder Factory Joint.** No anomalies were reported from the on sight inspection of this joint. No corrosion was

observed on the outer clevis leg or internal joint. Light corrosion was noted intermittently on the outer tang surface. Overall grease application was nominal in respect to the incorporated application technique. Insulation and Chemlok were found on the land forward of the primary O-ring groove 70 percent around the circumference of the joint.

Inspection of the large diameter O-rings found no damage on the primary or secondary O-rings.

**5.2.14.3 Center Forward Cylinder-to-Cylinder Factory Joint.** No anomalies were reported from the on sight inspection of this joint. No corrosion was observed on the outer clevis leg. Light corrosion was noted at the zero degree location inside the clevis end of the joint. Overall grease application was nominal in respect to the incorporated application technique. Insulation and Chemlok were found on the land forward of the primary O-ring groove intermittently around the circumference of the joint.

Inspection of the large diameter O-rings found no damage on the primary or secondary O-rings.

**5.2.14.4 Center Aft Cylinder-to-Cylinder Factory Joint.** No corrosion was observed on the outer clevis leg or internal joint. Overall grease application was nominal coverage in respect to the incorporated application technique. A small amount of fluid was noted in the clevis root at 1, 242

to 252, and 322 degrees. Laboratory analysis of the fluid showed the fluid to be inhibited water from the water knife.

Inspection of the large diameter O-rings found no damage on the primary or secondary O-rings.

**5.2.14.5 ETA-to-Stiffener Factory Joint.** No corrosion was observed on the outer clevis leg or internal joint. Overall grease application was nominal in respect to the incorporated application technique. Insulation and Chemlok were found on the land forward of the primary O-ring groove intermittently 50 percent around the circumference of the joint.

Light scratches and burnishes were noted at zero to 50 and 70 degrees on the land forward of the primary O-ring groove. Light scratches and burnishes were noted at 50, 150, 154, 298, 300 and 358 degrees on the land between the O-ring grooves. Light scratches and burnishes were also noted intermittently the full circumference on the chamfer of the tang indicating an interference fit during assembly.

No damage was noted on the large diameter primary and secondary O-rings.

**5.2.14.6 Stiffener-to-Stiffener Factory Joint.** No corrosion was observed on the outer clevis leg or internal joint. Overall grease application was light in respect to the incorporated application technique. Insulation and

Chemlok were found on the land forward of the primary O-ring groove intermittently 70 percent around the circumference of the joint.

Inspection of the large diameter O-rings found radial scratches at 156.4 and 241.3 degrees on the primary O-ring. The worst case scratch at 156.4 degrees measured 0.20 inch long, 0.002 inch wide and 0.002 inch deep.

**5.2.14.7 Aft Dome-to-Stiffener Factory Joint.** No corrosion was observed on the outer clevis leg or in the internal joint areas. The overall grease application was nominal. Insulation and Chemlok were found on the land forward of the primary O-ring groove intermittently 80 percent around the circumference of the joint.

Inspection of the port plug and port threads found no damage. Inspection of the large diameter O-rings found no damage on the primary or secondary O-rings.

### **5.3 Leak Check and Vent Port Plug Post-Flight Evaluations**

The evaluation of the port plugs after flight use consisted of adding to the port plug torque database, visual inspection of the port plug for damage, and visual inspection of the port plug O-rings for anomalies.

The port plugs had breakaway torques recorded. This exercise was done to add to the port plug torque database so evaluation of installation torque

levels and locking devices can be made on each port plug.

A summary of the post-flight inspection evaluations of the port plugs and port plug O-rings is contained in Table 1. Port plugs in the field joints and nozzle to case joints were removed during disassembly operations at KSC. Port plugs in the factory joints, internal nozzle joints and igniter were removed at Clearfield. An initial inspection was done at that time. Closure plugs were removed from the adjustable port plugs by the Thiokol O-ring Inspection Team. All port plugs and O-rings were then inspected by the Thiokol O-ring Inspection Team as a final inspection.

During the initial inspection at KSC several observations were reported. The most recurrent observation was extrusion damage to the O.D. and I.D. of the primary O-ring on the adjustable vent port plug. The extrusion damage was caused during installation of the port plug into the port. This damage is an acceptable condition due to the design of the primary seal. The primary O-ring is used as a packing seal. When the adjustable vent port plug is fully installed in the vent port, the primary O-ring extrudes out of the gland area and is damaged. The damage is inherent to the design. Light corrosion on the port plug heads and port spotfaces is another recurrent observation. The planning to install the port plugs has been updated on subsequent flights to include a more thorough application of grease preservative to the port area to prevent this type of corrosion.

Initial inspection of the port plugs removed at Clearfield continued to find several reoccurring problems. The lack of grease on some port plugs, O-rings and/or ports was noted. Port plug head gouges were reported on two factory joint leak check port plugs. The gouges are caused by pneumatic chisels used to remove the weather seal. The gouges do not affect the use or removal of the port plug but the breakaway torque readings taken for evaluation are invalidated.

The final inspection of the port plugs and O-rings by the Thiokol O-ring Inspection Team documented the I.D. cut observation on the shoulder O-ring from fifteen port plugs. The observation consists of a cut that extends circumferentially around the I.D. of the O-ring. The length and depth of the cut varies. A sharp last thread on the port plug is the cause of the cut. The cut occurs as the port plug is removed from the port and the O-ring is rubbed along the thread. O-ring installation aids were used to install the discrepant O-rings on the port plugs to prevent this type of damage during installation. The small punctures noted on the transducer secondary O-rings is caused by the tool used to remove the O-ring from the groove.

A circumferential scratch, 0.250 inch long, was noted on the dovetail of the left hand forward field joint vent port plug. Radial scratches were also noted on the seal surface of the right hand outer igniter leak check port plug.



**Table 1  
360H005 LEAK CHECK AND VENT PORT PLUG INSPECTION**

Joint Location	Part Inspected	LEFT HAND (5A)		RIGHT HAND (5B)	
		Initial Inspection	Final Inspection	Initial Inspection	Final Inspection
Forward Field	Adjust. Vent Port Plug	Corrosion on Port Spotface	No Damage	Corrosion on Port Spotface	No Damage
	Primary O-ring	No Damage	No Damage	O.D. Extrusion Damage	O.D. Extrusion Marks
	Sec. O-ring	No Damage	No Damage	No Damage	No Damage
	Closure Plug	No Damage	No Damage	No Damage	No Damage
	O-ring	No Damage	No Damage	No Damage	No Damage
	Leak Check Plug	No Damage	No Damage	No Damage	No Damage
	O-ring	No Damage	I.D. Circum. Cut (0.250 in. Length)	No Damage	I.D. Circum. Cut (0.140 in. Length)
Center Field	Adjust. Vent Port Plug	Corrosion on Port Spotface	Circum. Scratch on dovetail (0.010 in.)	No Damage	Raised metal on 1st intern. thread of top
	Primary O-ring	O.D. Circum. Impression	O.D. Extrusion Damage	No Damage	O.D. Extrusion Mark
	Secondary O-ring	No Damage	No Damage	No Damage	No Damage
	Closure Plug	No Damage	No Damage	No Damage	No Damage
	O-ring	No Damage	No Damage	No Damage	No Damage
	Leak Check Plug	No Damage	No Damage	No Damage	No Damage
	O-ring	No Damage	I.D. Circum. Cut (0.030 in. Length)	No Damage	I.D. Circum. Cut (0.050 in. Length)

**Table 1 (cont.)  
360H005 LEAK CHECK AND VENT PORT PLUG INSPECTION**

Joint Location	Part Inspected	LEFT HAND (5A)		RIGHT HAND (5B)	
		Initial Inspection	Final Inspection	Initial Inspection	Final Inspection
Aft Field	Adjust. Vent Port Plug	No Damage	No Damage	No Damage	No Damage
	Primary O-ring	No Damage	O.D. & I.D. extrusion Mark	O.D. Extrusion Damage	O.D. & I.D. extrusion mark
	Sec. O-ring	No Damage	No Damage	No Damage	No Damage
	Closure Plug	No Damage	No Damage	No Damage	No Damage
	O-ring	No Damage	No Damage	No Damage	No Damage
	Leak Check Plug	No Damage	No Damage	No Damage	No Damage
	O-ring	No Damage	I.D. Circum. Cut (0.450 in Length)	No Damage	No Damage
Nozzle to Case	Adjust. Vent Port Plug	Medium corros. on plug hex & port spotface	No Damage	corrosion on plug hex & port spotface	No Damage
	Primary O-ring	O.D. Extrusion Damage	O.D. & I.D. Extrusion Damage	O.D. Extrusion Damage	O.D. Extrusion Damage
	Sec. O-ring	No Damage	No Damage	No Damage	No Damage
	Closure Plug	No Damage	No Damage	No Damage	No Damage
	O-ring	No Damage	No Damage	No Damage	No Damage
	Leak Check Plug	Corrosion on spotface	No Grease on threads	Corrosion on spotface	No Damage
	O-ring	No Damage	No Damage	No Damage	I.D. Circum. Cut (0.350 in. Length)

**Table 1 (cont.)  
360H005 LEAK CHECK AND VENT PORT PLUG INSPECTION**

Joint Location	Part Inspected	LEFT HAND (5A)		RIGHT HAND (5B)	
		Initial Inspection	Final Inspection	Initial Inspection	Final Inspection
<b>Internal Nozzle Joints</b>					
No.1	Leak Check Plug	No Damage	No Damage	No Damage	No Damage
	O-ring	No Damage	No Damage	No Damage	No Damage
No.2	Leak Check Plug	No Damage	No Damage	No Damage	No Damage
	O-ring	No Damage	I.D. Circum. Cut (0.030 in. Length)	No Damage	No Damage
No.3	Leak Check Plug	No Damage	No Damage	No Damage	No Damage
	O-ring	No Damage	No Damage	No Damage	Poss. closed flow lines (0.040" Length)
No.4	Leak Check Plug	No Damage	No Damage	No Damage	No Damage
	O-ring	No Damage	No Damage	No Damage	O.D. Circum. Cut (0.200 in. Length)
No.5	Leak Check Plug	No Damage	No Damage	No Damage	No Damage
	O-ring	No Damage	No Damage	No Damage	No Damage
<b>Factory Joints</b>					
Forward Dome	Leak Check Plug	No Grease	Rolled Threads	Light grease	Rolled Thread
	O-ring	No Grease	No Damage	Light grease	No Damage
Forward Segment	Leak Check Plug	Light grease	No grease Rolled Threads	No grease	No grease
	O-ring	No Grease	I.D. circum. cut (0.150 in. No grease	No grease	Little Grease I.D. circum. cut (0.030 in length)

Table 1 (cont.)  
360H005 LEAK CHECK AND VENT PORT PLUG INSPECTION

Joint Location	Part Inspected	LEFT HAND (5A)		RIGHT HAND (5B)	
		Initial Inspection	Final Inspection	Initial Inspection	Final Inspection
Factory Joints					
Forward Center Segment	Leak Check Plug	No Damage	Lst thread has sm. depression		No Damage
	O-ring	No Damage	I.D. circum. Cut (0.050 in. length)		I.D. circum. Cut (0.070 in. length)
Aft Center Segment	Leak Check Plug	No Grease	No Grease	Light grease	No Damage
	O-ring	No Grease	No Grease	Light grease	I.D. Circum. Cut (0.250 in. length)
Attach to Stiffener	Leak Check Plug	Plg Hd Damaged Fluid in port	Rolled Threads No Grease	Plug Head Scratches Light grease	Rolled Thread
	O-ring	No Grease	No Grease I.D. Circum. Cut (0.350 in. Length)	Light grease	No Damage
Stiffener to Stiffner	Leak Check Plug	No Grease	No Damage	Plug head scratches Light grease	No Damage
	O-ring	No Grease	No Damage	Light grease	No Damage
Aft Dome	Leak Check Plug	No Grease	No Damage	Plug Head scratches Light grease	No Grease on threads
	O-ring	No Grease	I.D. Circum. Cut (0.100 in. Length)	No Damage	No Damage

**Table 1 (cont.)  
360H005 LEAK CHECK AND VENT PORT PLUG INSPECTION**

Joint Location	Part Inspected	LEFT HAND (5A)		RIGHT HAND (5B)	
		Initial Inspection	Final Inspection	Initial Inspection	Final Inspection
<b>Igniter</b>					
IPT	Transducer Primary O-ring	No Damage	No Damage	No Damage	No Damage
	Secondary O-ring	No Damage	No Damage	No Damage	Small Puncture
Outer Joint	Leak Check Plug	N/A	No Damage	N/A	Two radial Scratches (0.040 in. & 0.050)
	O-ring	N/A	No Damage	N/A	No Damage
Inner Joint	Leak Check Plug	N/A	No Damage	N/A	No Damage
	O-ring	N/A	No Damage	N/A	No Damage
Transd. 40 Deg.	Primary	No Damage	No Damage	No Damage	No Damage
	Secondary	No Damage	Sm. Puncture	No Damage	Small Puncture
Transd. 100 Deg.	Primary	No Damage	No Damage	No Damage	No Damage
	Secondary	No Damage	No Damage	No Damage	Small Puncture
Transd. 180 Deg.	Primary	No Damage	No Damage	No Damage	No Damage
	Secondary	No Damage	No Damage	No Damage	No Damage
Transd. 270 Deg.	Primary	No Damage	No Damage	No Damage	No Damage
	Secondary	No Damage	Sm. Puncture	No Damage	Small Puncture
Special Bolt 40 Deg.	Primary	No Damage	No Damage	No Damage	No Damage
	Stat-O-Seal	No Damage	No Damage	No Damage	No Damage
Special Bolt 100 Deg.	Primary	No Damage	No Damage	No Damage	No Damage
	Stat-O-Seal	No Damage	Closed flow Line	No Damage	No Damage

**Table 1 (cont.)  
360H005 LEAK CHECK AND VENT PORT PLUG INSPECTION**

Joint Location	Part Inspected	LEFT HAND (5A)		RIGHT HAND (5B)	
		Initial Inspection	Final Inspection	Initial Inspection	Final Inspection
<b>Igniter</b>					
Special Bolt 180 Deg.	Primary Stat-0-Seal	No Damage	No Damage	No Damage	No Damage
Special Bolt 270 Deg.	Primary Stat-0-Seal	No Damage	No Damage I.D. scratch (0.080 in.)	No Damage	No Damage

**5.4 Post-Flight Team Assessments**

The Component Program Teams (CPT) have reviewed all of the observations presented in this document and have determined that the following observations were "potential anomalies", classified as critical, major, minor or remains observation, as defined under Table 2 criteria.

Each "potential anomaly" is tracked by a Post-Fire Anomaly Record (PFAR). Corrective actions and results of the corrective action are recorded on the PFAR. Once all the corrective actions on the PFAR are completed, the PFAR is closed.

#### 5.4.1 Remains Observation

Two "potential anomalies" were classified as remains observation. These observations are:

1. Circumferential closed flow lines were found on an environmental seal of the right motor S&A. The largest measured 0.120 inch long.
2. Rolled threads on the last partial thread of leak check plugs removed from the right and left hand motor.

#### 5.4.2 Minor Anomalies

Nine "potential anomalies" were classified as minor anomalies. These minor anomalies are:

1. A small void was found in the O.D. of the S&A leak test port plug O-ring off the right hand motor. The void measured approximately 0.05 inch long, 0.015 inch wide and 0.003 inch deep.
2. Small copper particles were found in the grease on the high pressure side of the rotor shaft secondary O-rings in the right motor S&A.
3. Axial scratches were found across the Barrier-Booster rotor shaft housing bore primary and secondary seal surfaces on both right and left motor S&As.
4. Lack of/ or excessive grease was noted on the S&A leak test plugs. Two on right hand motor and one on the left motor.
5. Deformations were found on the sealing washer on the SII's. The deformations are circumferential and follow the pattern of the NSI. The largest deformations, located over the wrench slots, are approximately 0.003 inch deep. These deformations were noted on both SII's off of both right and left motors.

6. No grease on a leak check port plugs/ O-rings taken off the left and right hand motor.
7. Radial scratches on the seal surface of the outer igniter leak check port plug removed from the right motor.
8. Scratch on the dovetail of the adjustable vent port plug removed from the left motor.
9. Raised metal in the first internal thread of the top portion of the adjustable vent port plug removed from the right hand center field joint.

#### 5.4.3 Major Anomalies

One "potential anomaly" was classified as major anomaly. The major anomaly is:

1. An indentation found on the inner primary seal of the inner igniter gasket of the right hand motor at 220 degrees on the gasket aft face.

#### 5.4.4 Critical Anomalies

There were no critical anomalies.

#### 5.5 RPRB Position

Each PFAR was taken to the RPRB and presented as recommended by the Component Program Team. The RPRB was asked for acceptance of the PFAR as presented.

The RPRB has accepted all the recommendations as presented to the board (see Appendix A).



**Table 2  
Criteria for Classifying "Potential Anomalies"**

Remains Observation	Anomaly		
	Minor	Major	Critical
Requires no Specific Action	<p>Requires corrective action, but has no impact on:</p> <ul style="list-style-type: none"> <li>- Motor Performance</li> <li>- Program Schedule</li> </ul> <p>Does not reduce usability of part for its intended function</p> <p>Could cause damage preventing reuse of hardware in combination with other anomaly</p> <p>Significant departure from the historical database</p>	<p>Could cause failure in combination w/ other anomaly</p> <p>Could cause damage preventing reuse of hardware</p> <p>Program acceptance of cause, corrective action, and risk assessment required before subsequent static test or flight</p>	<p>Violates CEI Spec. requirements</p> <p>Could cause failure and possible loss of mission/life</p> <p>Mandatory resolution before subsequent static test/flight</p>
<p><b>Note:</b> These criteria to be applied to the specific observed "potential anomaly" as it relates to the observed article and as it relates to subsequent articles.</p>			

## 6.0 REFERENCES

1. R. Ash, TWR-18761, Rev. A, "O-Ring Squeeze Calculations and Temperature Requirements 360H005", Morton Thiokol, Inc., July 1989.
2. J. R. Heman, TWR-18798, "Redesigned Solid Rocket Motors 360H005 Seal Leak Test Results", Morton Thiokol, Inc., June 1989.
3. Performance and Advanced Design, et. al., TWR-16475, Book 1, Volumes 1-9, "KSC Post-Flight Engineering Evaluation Plan", Morton Thiokol, Inc., 21 April 1989 (Vol. 4, Rev. D, Seals Component)
4. Performance and Advanced Design, et. al., TWR-16475, Book 2, Volumes. 1-9, "Clearfield Post-Flight Engineering Evaluation Plan", Morton Thiokol, Inc., 14 April 1989 (Vol. 4, Seals Component)

**APPENDIX A**  
**RPRB PRESENTATIONS**

# RPRB PRESENTATION

## 360H005 SEAL COMPONENTS POST FLIGHT EVALUATION AT KSC

6 SEPTEMBER 1989

J.T. CURRY  
JOINTS AND SEALS DESIGN

### COORDINATED WITH:

PM: B. Crosbie

IE: K. Kobayashi

DE: G. Abawi

QE: P. Fearn

SE: D. Starrett

QA: G. Nielson

Reliability: J. Richards

*Thiokol* CORPORATION  
SPACE OPERATIONS

INFORMATION ON THIS PAGE WAS PREPARED TO SUPPORT AN ORAL PRESENTATION  
AND CANNOT BE CONSIDERED COMPLETE WITHOUT THE ORAL DISCUSSION

## INTRODUCTION

---

### 360H005B IGNITER GASKET INDENTATION

#### PROBLEM REPORT:

- KSC PR No. PV6-137080
- PFAR No. 360H005B-04

#### DESCRIPTION:

- AN INDENTATION WAS FOUND ON THE INNER PRIMARY SEAL OF THE INNER IGNITER GASKET (P/N 1U51926-01, S/N 28) OF THE 5B MOTOR AT 220 DEGREES ON THE GASKET AFT FACE. THE CROWN OF THE SEAL WAS DEPRESSED INWARD AND MEASURED APPROXIMATELY 0.10 INCH LONG CIRCUMFERENTIALLY BY 0.025 INCH WIDE RADIALLY.
- PRESENTED TO EMT ON 25 AUGUST 1989

*Thiokol* CORPORATION  
SPACE OPERATIONS

## INTRODUCTION cont.

---

### TEAM CLASSIFICATION:

- Major Anomaly with Corrective Action

### RELIABILITY:

- SPR No. DR4-5/168.

### IN FLIGHT ANOMALY:

- IFA No. STS-28-M-1.

*Thiokol* CORPORATION  
SPACE OPERATIONS

INFORMATION ON THIS PAGE WAS PREPARED TO SUPPORT AN ORAL PRESENTATION  
AND CANNOT BE CONSIDERED COMPLETE WITHOUT THE ORAL DISCUSSION

QM-7/ 360L003B IGNITER GASKET INDENTATION

PROBLEM REPORT:

- PFAR No. QM-7-007
- NO PR WRITTEN.

DESCRIPTION:

- AN INDENTATION WAS FOUND ON THE PRIMARY SEAL OF THE OUTER IGNITER GASKET (P/N 1U51927-01, S/N 4R1) OF THE QM-7/ 3B MOTOR AT 97 DEG. ON THE GASKET FORWARD FACE. THE CROWN OF THE SEAL WAS DEPRESSED OUTWARD FROM THE MOTOR CENTERLINE.
- INDENTATION SMALLER THAN OTHERS PREVIOUSLY REPORTED. NOT VISUALLY APPARENT UNTIL COMPRESSED UNDER PLEXIGLAS FIXTURE.
- ANOMALY DOCUMENTATION DISCOVERED DURING INVESTIGATION OF 360H005B GASKET PROBLEM.
  - IMPROPER DOCUMENTATION OF OBSERVATION ON QM-7 PFOR SHEET.
  - QM-7 OBSERVATION DOCUMENTED IN MEMO L224:FY89:086

*Thiokol* CORPORATION  
SPACE OPERATIONS

**TEAM CLASSIFICATION:**

- Major Anomaly with Corrective Action

**RELIABILITY:**

- SPR No. DR4-5/171



## HISTORY

---

- **DM-9 OUTER GASKET**

- **A DEPRESSION IN THE CROWN OF THE PRIMARY SEAL WAS FOUND AT 144 DEGREES. ANOMALY WAS THE RESULT OF TRAPPED GAS (VOID) AND NITRILE RESIDUE (CONTAMINATION). CLASSIFIED MAJOR ANOMALY BY RPRB.**

- **QM-6 SAFE AND ARM GASKET**

- **A DEPRESSION IN THE CROWN OF THE PRIMARY SEAL WAS FOUND AT 225 DEGREES. APPROXIMATE DIMENSIONS ARE 0.25 INCH LONG BY 0.0156 INCH DEEP. ANOMALY WAS THE RESULT OF TRAPPED GAS (VOIDS) AND MOLD DEFECT. CLASSIFIED MAJOR ANOMALY BY RPRB.**
- **THERE IS CURRENTLY NO VENDOR INSPECTIONS TO FIND SUBSURFACE VOIDS OR POROSITY.**
- **CORRECTIVE ACTION TO IMPROVE SEAL INSPECTION NOT COMPLETED**

*Thiokol* CORPORATION  
SPACE OPERATIONS

INFORMATION ON THIS PAGE WAS PREPARED TO SUPPORT AN ORAL PRESENTATION  
AND CANNOT BE CONSIDERED COMPLETE WITHOUT THE ORAL DISCUSSION

## CONCLUSIONS

---

- INDENTATION IS CAUSED BY A SUBSURFACE VOID OR POROUS REGION.
  - TO BE CONFIRMED WHEN SEAL IS DISSECTED
- HISTORY SHOWS INDENTATIONS ARE DISCOVERED AFTER USE OF NEW OR NEWLY REFURBISHED GASKETS.
- THE ANOMALY BECOMES EVIDENT AFTER THE GASKET IS COMPRESSED IN AN ASSEMBLY.
- NO VOIDS HAVE BEEN DETECTED ON GASKETS THAT HAVE HAD PREVIOUS USE. (AFTER SECOND OR SUBSEQUENT USE)

*Thiokol* CORPORATION  
SPACE OPERATIONS

INFORMATION ON THIS PAGE WAS PREPARED TO SUPPORT AN ORAL PRESENTATION  
AND CANNOT BE CONSIDERED COMPLETE WITHOUT THE ORAL DISCUSSION

## SHORT TERM CORRECTIVE ACTION RECOMMENDATIONS

---

- TEAM MEETING WITH VENDOR TO INVESTIGATE PREVIOUS CORRECTIVE ACTIONS AND IMPLEMENTATION.
- REPLACE ALL NEW OR NEWLY REFURBISHED GASKETS WITH ACCEPTABLE USED GASKETS.
  - VISUAL, HAND AND PLEXIGLAS INSPECTION DONE ON GASKETS
- FLIGHT 6
  - REMOVE AND REPLACE IGNITER OUTER AND S&A GASKETS WITH USED GASKETS. (BOTH 360LOO6 OUTER GASKETS ARE NEW)
    - OPERATION WILL REQUIRE REPLACEMENT OF ATTACH BOLTS AND OPT's
    - OPERATION WILL REQUIRE NEW LEAK TESTS ON S&A, OPT's AND IGNITER OUTER JOINT.
- FLIGHT 7
  - THE SAME RECOMMENDATIONS AND CONDITIONS EXIST FOR FLIGHT 7

*Thiokol* CORPORATION  
SPACE OPERATIONS

INFORMATION ON THIS PAGE WAS PREPARED TO SUPPORT AN ORAL PRESENTATION  
AND CANNOT BE CONSIDERED COMPLETE WITHOUT THE ORAL DISCUSSION

## LONG TERM CORRECTIVE ACTION RECOMMENDATIONS

---

- DETERMINE A METHOD FOR INSPECTION OF SUBSURFACE VOIDS AT THE VENDOR USING TESTING.
- NON DESTRUCTIVE IN-HOUSE TESTING (3RD and 5TH FLIGHT GASKETS)
  - X-RAY
  - COLD DYNAMIC TESTING
  - INSPECT USING PLEXIGLAS INSPECTION TOOL
    - DETERMINE IF ANOMALY CAN BE DETECTED WITH COMPRESSION LOAD OF 3600-4000 PSI (COMPLETED)
    - PHOTOGRAPHS TAKEN BEFORE, DURING, AND AFTER TESTING

*Thiokol* CORPORATION  
SPACE OPERATIONS

INFORMATION ON THIS PAGE WAS PREPARED TO SUPPORT AN ORAL PRESENTATION  
AND CANNOT BE CONSIDERED COMPLETE WITHOUT THE ORAL DISCUSSION

## LONG TERM CORRECTIVE ACTION RECOMMENDATIONS (CONTINUED)

---

- AFTER PLEXIGLAS INSPECTION, THE GASKET WILL BE GIVEN TO ADVANCED TECHNOLOGY TO FURTHER INVESTIGATE INSPECTION TECHNIQUES
  - BACK SCATTER X-RAY, CATSCAN, N-RAY, SHEAROGRAPHY, ACOUSTICAL, ELASTODYNAMICS (OUT OF HOUSE TESTING)
  - THIS WORK SHOULD HAVE TOP PRIORITY IN THE EVENT A VOID INSPECTION IS REQUIRED PRIOR TO FLIGHT 6 (AND SUBSEQUENT)

*Thiokol* CORPORATION  
SPACE OPERATIONS

INFORMATION ON THIS PAGE WAS PREPARED TO SUPPORT AN ORAL PRESENTATION  
AND CANNOT BE CONSIDERED COMPLETE WITHOUT THE ORAL DISCUSSION

## LONG TERM CORRECTIVE ACTION RECOMMENDATIONS (CONTINUED)

---

- **DESTRUCTIVE INVESTIGATION**
  - **RESILIENCY TESTING OF GASKET TO BE PERFORMED AT VOID AND REGIONS AWAY FROM THE VOID**
  - **ANALYZE INDENTATION ANOMALY AND INVESTIGATE SOURCE OF PROBLEM**
    - **DISSECT VOID**
    - **PERFORM LAB WORK**
      - **INFRA-RED ANALYSIS OF MATERIAL**
      - **STEREOSCOPIC MICROSCOPE INSPECTION**
      - **OTHER**
- **ALTERNATE SEAL DESIGN AS PART OF PRODUCT IMPROVEMENT PROGRAM**

*Thiokol* CORPORATION  
SPACE OPERATIONS

INFORMATION ON THIS PAGE WAS PREPARED TO SUPPORT AN ORAL PRESENTATION  
AND CANNOT BE CONSIDERED COMPLETE WITHOUT THE ORAL DISCUSSION

**RPRB PRESENTATION**  
**SEALS DISASSEMBLY REPORT**

**06 DECEMBER 1989**

**K. S. BAKER**  
**JOINTS AND SEALS DESIGN**

**PM: B. CROSBIE**  
**SIE: D. PULLEYN**  
**FP: D. STARRETT**  
**DE: K. BAKER, L. NELSEN, A. CARLISLE, G. ABAWI**  
**QE: P. FEARNES, L. ROBISON**  
**Rel: J. RICHARDS**

*Thiokol* CORPORATION  
SPACE OPERATIONS

INFORMATION ON THIS PAGE WAS PREPARED TO SUPPORT AN ORAL PRESENTATION  
AND CANNOT BE CONSIDERED COMPLETE WITHOUT THE ORAL DISCUSSION

■PFARs: 360T004A-20

■DESCRIPTION:

- A small piece of flashing was found to have been molded into the I.D. of the M83248/1 BB leak test port plug O-ring.

■HISTORY: Not previously seen on this O-ring, but this type of anomaly has been seen on other small O-rings.

■DISCUSSION:

- The BB assembly drawing calls out M83248/1 O-ring as the primary call out for the BB leak test port plug secondary seal
- The alternate call out is to use 1U50228 or 1U76145
  - M83248/1 O-rings are not 100% inspected, lot acceptance is how they are received.
  - 1U50228 is the current acceptable flight O-ring for all the other leak test port plug O-rings on the motor.
  - 1U76145 drawing has been canceled.

■RECOMMENDATIONS:



▪ **TEAM CLASSIFICATION: Minor Anomaly**

▪ **JUSTIFICATION:**

▪ This has no impact on motor performance because this is a packing seal and it does not experience any dynamic movement during motor operation.

▪ **CORRECTIVE ACTION:**

▪ Short term; change assembly planning so that, were available, 1U50228 O-rings are used in the assembly of the S&A.

▪ Long term; remove all alternate O-rings from the three (1U52293, 294, and 295) assembly drawings and replace with the equivalent 1U50228 O-ring, except for environmental seals.

▪ **REPORT BACK TO RPRB? NO**

▪ **ACTIONEE: S&A Component Program Team for actions 1&2.**

▪ **PFARs: 360H005B-29, TEM04-02**

▪ **DESCRIPTION:**

▪ Circumferential closed flow lines were found on two environmental seals of the S&A, the largest measured 0.120 inch long.

▪ **HISTORY:** Not previously seen on these O-rings, but this type of anomaly has been seen on other small O-rings.

■ **DISCUSSION:**

- **Flow lines are caused during the molding process when the material introduced into the mold does not flow properly. Inherent to compression molding process.**
- **All the environmental seals in the S&A are Mil. Spec. O-rings which are not 100% inspected.**

■ **RECOMMENDATIONS:**

- **TEAM CLASSIFICATION: Remains Observation**

- **JUSTIFICATION:**

- **Environmental seals are designed to keep contamination out of the S&A under ambient conditions, flow lines on these O-rings will not impair this function because they close up when squeezed.**

- **CORRECTIVE ACTION:**

- **Change Post Fire Engineering Evaluation Limits (PEEL) to say flow lines on the S&A environmental seals are acceptable.**

- **REPORT BACK TO RPRB? No**

- **ACTIONEE: Joints and Seals Design.**

■ **PFARs: 360L003B-14**

**■DESCRIPTION:**

- Two open radial flow lines were found on the forward field joint leak test port plug O-ring (lot 56). Approx. length of largest open flow line was 0.090 inch.

**■HISTORY: Previously found on 1st flight center aft cyl. to cyl. factory joint.**

- Presented to RPRB on 15 February 1989 with the following corrective action:
  - Dedicated 16 hole mold for 1U50228-15 O-ring starting with lot 47
  - Purged from stores all -15 O-rings prior to lot 47.
- All -15 O-rings from lot 56 were re-inspected, none were found any anomalies.

# SEALS DISASSEMBLY REPORT

---



360L003B FORWARD FIELD JOINT AT 45 DEG  
LEAK CHECK PLUG SECONDARY O-RING  
1U50228-15 ECL0056

ORIGINAL PAGE IS  
OF POOR QUALITY

*Thiokol* CORPORATION  
SPACE OPERATIONS

INFORMATION ON THIS PAGE WAS PREPARED TO SUPPORT AN ORAL PRESENTATION  
AND CANNOT BE CONSIDERED COMPLETE WITHOUT THE ORAL DISCUSSION

## SEALS DISASSEMBLY REPORT

---

### ■DISCUSSION:

- Flow lines are caused during the molding process when the material introduced into the mold does not flow properly. Inherent to compression molding process.

### ■RECOMMENDATIONS:

- TEAM CLASSIFICATION: Minor Anomaly

### ■ JUSTIFICATION:

- This has no impact on motor performance because this is a packing seal and it does not experience any dynamic movement during motor operation.

### ■ CORRECTIVE ACTION:

- Implement the use the new base line O-ring material, STW4-3339.
- Implement new acceptance criteria for small O-rings, STW3-3744.
- Implement a dedicated O-ring molding area at the vendor
- Write a memo to inspection personnel to alert them to this type of problem.

- REPORT BACK TO RPRB? yes

- ACTIONEE: O-ring Component Program Team for actions 1-3, Quality Engineering

*Thiokol* CORPORATION  
SPACE OPERATIONS

## SEALS DISASSEMBLY REPORT (Cont.)

---

for action 4.

■ PFARs: 360L006A-34

■ DESCRIPTION:

■ A closed radial flow line was found on the 18 degree SII secondary O-ring of the LH motor.

■ HISTORY: Closed flow lines have previously found small O-ring but not on this particular part number.

■ DISCUSSION:

■ This particular O-ring (1U52296) is not inspected to 1U50228 criteria.

■ Flow lines are caused during the molding process when the material introduced into the mold does not flow properly. Inherent to compression molding process.

■ RECOMMENDATIONS:

■ TEAM CLASSIFICATION: Minor Anomaly

■ JUSTIFICATION:

*Thiokol* CORPORATION  
SPACE OPERATIONS

## SEALS DISASSEMBLY REPORT (Cont.)

---

- This joint does not experience any dynamic movement, i.e. gap growth.
- This O-ring is leak tested at 50 psig which is designed to find O-ring flaws that would not seal during motor operation.
- **CORRECTIVE ACTION:**
  - Re-inspect all in-house 1U52296 O-rings to 1U50228 criteria.
  - Procure equivalent 1U50228 O-rings (-38).
  - Change assembly drawing to call out the 1U50228-38 O-ring (same corrective action as PFAR 360T004A-20).
- **REPORT BACK TO RPRB?**
- **ACTIONEE:** Quality Engineering for action 1, O-ring Component Program Team for action 2, S&A Component Program Team for action 3.
- **PFARs:** 360H005B-19
- **DESCRIPTION:**
  - A small void was found in the O.D. of the S&A leak test port plug O-ring (1U50228-25, lot 19), measures approx. 0.05 inch in circumferential length by

*Thiokol* CORPORATION  
SPACE OPERATIONS

## SEALS DISASSEMBLY REPORT (Cont.)

---

0.015 inch wide radially by 0.003 inch deep

■ **HISTORY:** Not previously seen.

■ **DISCUSSION:**

- Most probable cause is; the void was caused during the molding process.
  - The material does not flow properly and causes trapped air pockets or no-fill areas before complete gland fill.

*Thiokol* CORPORATION  
SPACE OPERATIONS



# SEALS DISASSEMBLY REPORT

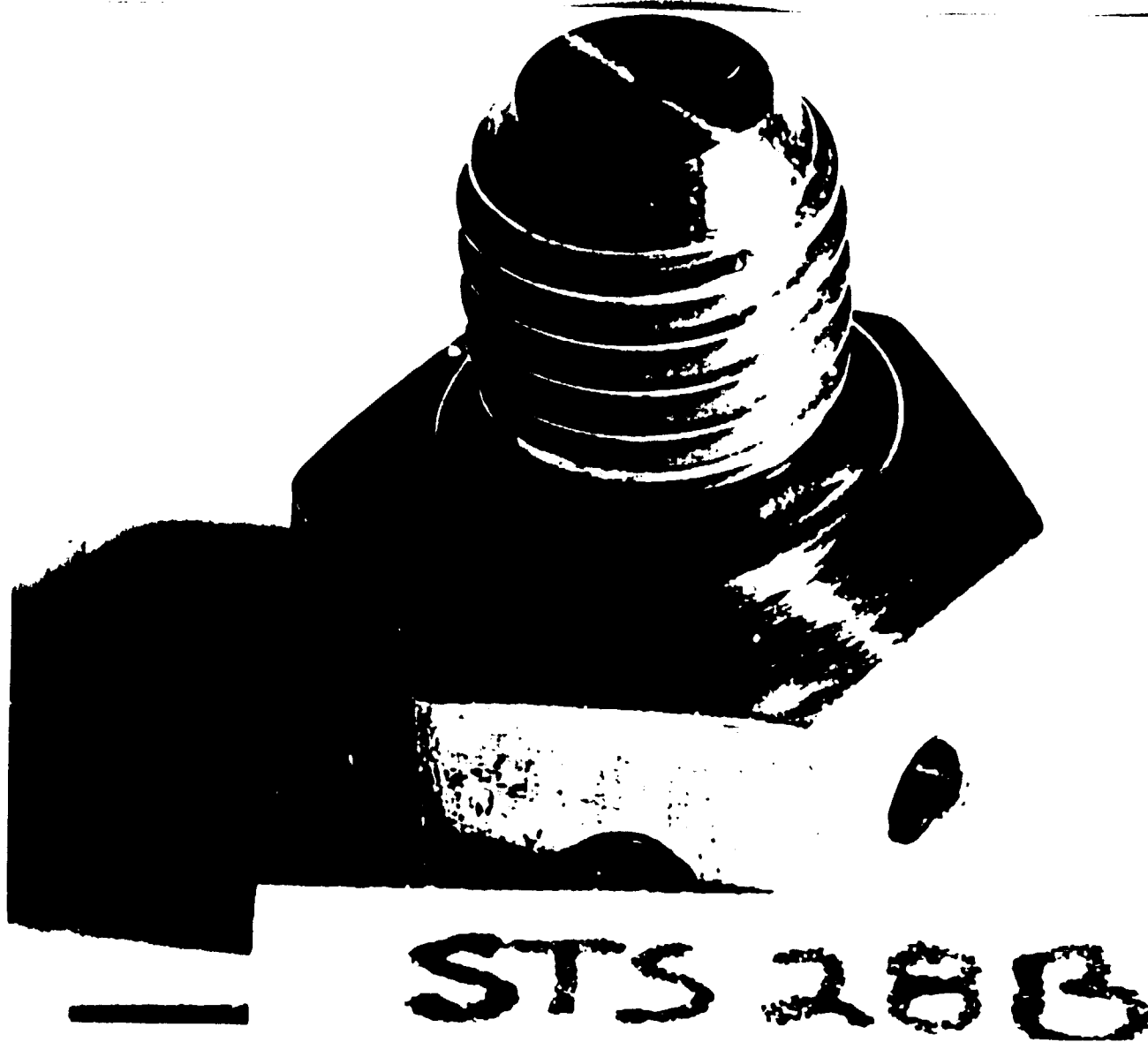

ORIGINAL PAGE IS  
OF POOR QUALITY

*Thiokol* CORPORATION  
SPACE OPERATIONS

INFORMATION ON THIS PAGE WAS PREPARED TO SUPPORT AN ORAL PRESENTATION  
AND CANNOT BE CONSIDERED COMPLETE WITHOUT THE ORAL DISCUSSION

## SEALS DISASSEMBLY REPORT

---

### ■RECOMMENDATIONS:

- TEAM CLASSIFICATION: Minor Anomaly

- JUSTIFICATION:

- This has no impact on motor performance because this is a packing seal and it does not experience any dynamic movement during motor operation.

- CORRECTIVE ACTION:

- Write a memo to inspection personnel to alert them to this type of problem.
  - Implement actions 2-4 of PFAR 360L003B-14

- REPORT BACK TO RPRB?

- ACTIONEE: Quality Engineering for action 1, O-ring Component Program Team for action 2.

- PFARs: 360L006A-23, 360L006B-24

### ■DESCRIPTION:

- The LH outer gasket environmental seal had intermittent shear separation

*Thiokol* CORPORATION  
SPACE OPERATIONS

## SEALS DISASSEMBLY REPORT (Cont.)

---

around the edge of the retainer, largest separation measured approx. 2 inches long.

- The RH outer gasket environmental seal was sheared off the edge of the retainer from 175 to 320 degrees.

### REFERENCE: PFAR TEM02-01

▪ **HISTORY:** Previously found on TEM-02 and TPTA 2.3, presented to RPRB on 28 July 1989.

- Recommendations from PFAR TEM02-01 have been incorporated into the baseline manufacturing plan at the vendor.
- Limits for acceptable damage to the environmental seal have been added to the PEEL, effective seventh flight.

### ▪ **DISCUSSION:**

- This damage is probably the result of a combination of factors, they being:
  - Reuse of Gaskets, all four damaged environmental seals were on reused gaskets.
    - Long range program plan is to not reuse gaskets.
  - Possible contamination of the bondline with xylene primer (part of the cause

*Thiokol* CORPORATION  
SPACE OPERATIONS

## SEALS DISASSEMBLY REPORT (Cont.)

---

of the TEM-02 problem).

- When a load is applied to the igniter adapter, during bolt pre-loading, a shearing action is applied to the seal at the O.D. of the gasket retainer.

### ▪RECOMMENDATIONS:

- TEAM CLASSIFICATION: Minor Anomaly

- JUSTIFICATION:

- Even with the missing portion of the seal, there is still a portion of the seal still bonded to the lip of the retainer. With the remaining portion of the seal, the part still functions as intended.

- CORRECTIVE ACTION:

- Close this PFAR.

- REPORT BACK TO RPRB? no

- ACTIONEE: Joints and Seals Design.

### ▪PFARs: 360L006B-33

*Thiokol* CORPORATION  
SPACE OPERATIONS

## SEALS DISASSEMBLY REPORT (Cont.)

---

### ■DESCRIPTION:

- Of the 100 packing with retainers from the RH motor, three had closed flow lines and three had open flow lines.

### REFERENCE: PFAR QM8-04

### ■HISTORY: First found on QM-8 and presented to RPRB on 8 March 1989 as a major anomaly.

- Presented to EMT for third flight as remains observation.
- Corrective action from QM-8 had a flight effectivity of 6B.
  - All motors previous to 6B have been classified as remains observation.

### ■DISCUSSION:

- Flow lines are caused during the molding process when the material introduced into the mold does not flow properly. Inherent to compression molding process.
- MIL-STD-413 is the current inspection criteria for packing with retainers.
  - This standard was clarified and implemented for 6B.

### ■RECOMMENDATIONS:

- TEAM CLASSIFICATION: Minor Anomaly

*Thiokol* CORPORATION  
SPACE OPERATIONS

## SEALS DISASSEMBLY REPORT (Cont.)

---

### ■ JUSTIFICATION:

- Testing done on packing with retainers with open flow lines from QM-8, has shown that they functioned as designed even with open flow lines.

### ■ CORRECTIVE ACTION:

- Write a memo to inspection personnel to alert them to this type of problem.
- Release packing with retainer acceptance specification (STW3-3780)
  - ECP-1974 in review at MSFC.
- Close this PFAR if no flow lines are found the seventh flight packing with retainers.

- REPORT BACK TO RPRB? yes, give results of seventh flight assessment.

- ACTIONEE: Quality Engineering for action 1, Joints and Seals Design for action 2.

■PFARs: 360L006A-32

### ■DESCRIPTION:

*Thiokol* CORPORATION  
SPACE OPERATIONS

## SEALS DISASSEMBLY REPORT (Cont.)

---

- The secondary O-ring of dual seal plug that was used to plug the igniter pressure port had a I.D. cut, full circumference.
  
- **HISTORY:** Not previously seen.
  
- **DISCUSSION:**
  - Most likely cause of this cut is from over fill of the dove tail groove on the dual seal plug.
    - Measurements of the O-ring, show it to be nominal size.
    - Actual plug was scraped during igniter adapter refurb.
      - This lot of plugs had a DR written against them for the dove tail groove being to shallow.
  - Removal of plug required approximately the same torque to remove as the comparable part in the RH motor.
    - Plug is lock wired in place.
  
- **RECOMMENDATIONS:** Classification and corrective actions will be determined by the Component Program Team.

*Thiokol* CORPORATION  
SPACE OPERATIONS

**RPRB PRESENTATION**  
**S&A DISASSEMBLY REPORT**

**10 JANUARY 1990**

**G. S. EDEN**  
**JOINTS AND SEALS DESIGN**

**PM: L. HANKINS, S. MEDRANO**  
**SIE: T. GREGORY**  
**FP: D. STARRETT**  
**DE: S. EDEN, D. BULLARD, K. BAKER**  
**QE: R. DAWES**  
**Rel: G. CONOVER**

*Thiokol* CORPORATION  
SPACE OPERATIONS

INFORMATION ON THIS PAGE WAS PREPARED TO SUPPORT AN ORAL PRESENTATION  
AND CANNOT BE CONSIDERED COMPLETE WITHOUT THE ORAL DISCUSSION



# S&A DISASSEMBLY REPORT

---

## OVERVIEW:

## CLASSIFICATION

- |   |                     |
|---|---------------------|
| 1- Copper particles on rotor shaft secondary O-rings        | Minor Anomaly       |
| 2- Axial scratches across housing bore sealing surfaces     | Minor Anomaly       |
| 3- Axial scratch on rotor shaft secondary O-ring groove     | Minor Anomaly       |
| 4- Lack of/excess grease on leak test plug                  | Minor Anomaly       |
| 5- Galling on leak test plug shoulder seal surface          | Minor Anomaly       |
| 6- Radial scratch across leak test plug seal surface        | Minor Anomaly       |
| 7- Chipped thread on leak test plug                         | Minor Anomaly       |
| 8- Circ. scratch on shoulder seal surface of leak test port | Minor Anomaly       |
| 9- Contamination on shoulder seal surface of SII port       | Remains observation |
| 10- NSI/SII thread continuation into shoulder seal surface  | Minor Anomaly       |
| 11- Radial scratch across shoulder seal surface of SII port | Minor Anomaly       |
| 12- Deformation in sealing washer of SII                    | Minor Anomaly       |
| 13- Radial scratch across sealing washer of SII             | Minor Anomaly       |
| 14- Radial scratch across SII port secondary O-ring groove  | Minor Anomaly       |

*Thiokol* CORPORATION  
SPACE OPERATIONS

# S&A DISASSEMBLY REPORT

---

- **PFARs:** 360H005B-16, 360L006A-15, 360L006B-16
  
- **DESCRIPTION:**
  - Small copper particles were found on the high pressure side of the rotor shaft secondary O-rings. Lab analysis confirmed the particles to be copper.
  
- **HISTORY:** First found on the 5B Barrier Booster. Similar particles were found on B-B's from 6A, and 6B. No contamination was found on 7A or 7B.
  
- **DISCUSSION:**
  - The copper particles have only been found on the high pressure side of the rotor shaft secondary O-ring.
  
  - The copper is being introduced into the leak test cavity in the rotor housing bore during the high pressure leak test at the vendor, Eaton Valve and Actuator Division (E-VAD).
    - A copper Conoseal is used in the connection between the pressure line and the leak test port adapter. Conoseals from the line were inspected and found to be flaking under use.

*Thiokol* CORPORATION  
SPACE OPERATIONS

# S&A DISASSEMBLY REPORT

---

- **DISCUSSION (cont.)**
  - **The copper particles come in contact with the secondary O-rings when the rotor shaft is removed from the housing bore; the O-rings wipe the grease and copper from the bore as it passes through.**
  
- **RECOMMENDATIONS:**
  - **TEAM CLASSIFICATION: Minor Anomaly**
  
  - **JUSTIFICATION:**
    - **Violates engineering and requires corrective action.**
  
    - **Has no impact on motor performance because:**
      - **The rotor shaft is installed into the housing bore before leak testing is performed,**
  
      - **The rotor shaft seals passed two high pressure and one low pressure leak test.**

# S&A DISASSEMBLY REPORT

---

- **CORRECTIVE ACTION:**
  - **Short term: Add E-VAD planning change to blow the pressure line clean prior to each hook-up.**
    - **Implement an in-line filter in the leak test equipment to prevent any contamination from entering the bore.  
Effective: 19 January 1990.**
  - **Long term: Modify the 8U leak test equipment to replace all copper fittings.**
- **REPORT BACK TO RPRB? No**
- **ACTIONEE: S&A Component Team for short term, Joints and Seals Design for long term.**

# S&A DISASSEMBLY REPORT

---

- **PFARs:** 360T004A-18, 360T004B-19, 360H005A-14, 360H005B-15, TEM04-11, LAT41-04
- **DESCRIPTION:**
  - Several axial scratches were found across the B-B rotor shaft housing bore primary and secondary seal surfaces. The scratches vary in length and have a maximum depth of approximately 0.4 mils.
- **HISTORY:** No history of scratches in the housing bore previous to 360T004 have been reported.
- **DISCUSSION:**
  - The housing bore is made of soft material (304 Stainless) and is easily scratched.
  - The most probable cause of the scratches is the bore measurement inspection tool.
    - Up to Sixth Flight, E-VAD's planning did not require inspection of the bore after bore measurement.

# S&A DISASSEMBLY REPORT

---

- **DISCUSSION (cont.)**

- The refurbishment specification, STW7-3133, does not specifically call out inspection point for the housing bore.

- **RECOMMENDATIONS:**

- **TEAM CLASSIFICATION:** Minor Anomaly

- **JUSTIFICATION:**

- Violates engineering and requires corrective action.
- B-B's with scratched bores have passed the high and low pressure leak tests.
- Post-fire inspection found no damage to the rotor shaft O-rings.

- **CORRECTIVE ACTION:**

- **Short Term:** Modify vendor planning to inspect all B-B rotor housing bore seal surfaces for damage prior to rotor installation.

*Thiokol* CORPORATION  
SPACE OPERATIONS

# S&A DISASSEMBLY REPORT

---

- **CORRECTIVE ACTION (cont.)**
  - **Short Term:**
    - **OCR implemented- Effective: Sixth Flight.**
  - **Long Term: Replace bore measurement inspection tool with air micrometer.**
  - **Update refurbishment specification, STW7-3133, to incorporate better seal surface definitions and inspection points.**
- **REPORT BACK TO RPRB? No**
- **ACTIONEE: S&A Component Team and Joints and Seals Design.**

# S&A DISASSEMBLY REPORT

---

- **PFARs:** TEM04-03
- **DESCRIPTION:**
  - Small axial scratch found on B-B rotor shaft secondary O-ring groove; approximate length was 30 mils.
- **HISTORY:** Not previously reported.
- **DISCUSSION:**
  - Occurrence unknown; scratch probably occurred at O-ring removal during refurbishment.
- **RECOMMENDATIONS:**
  - **TEAM CLASSIFICATION:** Minor Anomaly
  - **JUSTIFICATION:**
    - Violates engineering and requires corrective action.
    - The rotor shaft seals passed both high and low pressure leak tests.

*Thiokol* CORPORATION  
SPACE OPERATIONS



## S&A DISASSEMBLY REPORT

---

- **JUSTIFICATION (cont.):**
  - No rotor shaft O-ring damage has been found due to scratches in the housing bore: *rotor shaft O-ring groove.*
- **CORRECTIVE ACTION:**
  - **Short Term:** Clarify inspection point of the rotor shaft O-ring groove seal surfaces in vendor (E-VAD) planning.
    - Implement non-metallic O-ring removal tool in all places that require removal of O-rings. Effective: 19 January 1990
  - **Long Term:** Update refurbishment specification, STW7-3133, to incorporate better seal surface definitions and inspection points.
- **REPORT BACK TO RPRB?** No
- **ACTIONEE:** S&A Component Team and Joints and Seals Design.

## S&A DISASSEMBLY REPORT

---

- **PFARs:** 360L001A-48, 360L003B-15, 360H005A-17, 360H005B-18, 360H005B-31, TEM04-04, LAT41-02
  
- **DESCRIPTION:**
  - **Lack of/excess grease found on S&A leak test (MS9902-01) plugs.**
  
- **HISTORY:** First, Third, and Fifth Flights, TEM-04, and LAT-41.
  
- **DISCUSSION:**
  - **Thiokol planning does not specify amount of grease to be applied to B-B leak test plug or O-ring.**
  
  - **KSC planning (OMI) did not require grease application to the S&A-to-adapter leak test plug or O-ring prior to Sixth Flight.**
    - **OMI update for proper grease application effective Sixth Flight.**
  
  - **Grease is used as a lubricant for the O-ring; a lack of grease could damage the O-ring upon assembly and excess grease could cause an overfill condition and result in O-ring extrusion damage.**

*Thiokol* CORPORATION  
SPACE OPERATIONS

# S&A DISASSEMBLY REPORT

---

- **RECOMMENDATIONS:**
  - **TEAM CLASSIFICATION:** Minor Anomaly
  - **JUSTIFICATION:**
    - Potential for O-ring damage.
    - Corrective action is required.
    - No O-ring damage has been found due to a lack of or excessive grease on the MS9902-01 leak test plug.
  - **CORRECTIVE ACTION:**
    - Short Term: Update Thiokol planning to quantify grease application to the leak test plugs and O-rings. Effective: 19 January 1990

*Thiokol* CORPORATION  
SPACE OPERATIONS

## S&A DISASSEMBLY REPORT

---

- **CORRECTIVE ACTION (cont.):**
  - **Long Term: Implement TRACS at Thiokol and KSC for proper grease application techniques and update the grease spec to incorporate small O-rings.**
  - **Add limits to PEEL stating lack of/excessive grease is reportable.**
  - **Modify grease specification, STW7-2999, to incorporate small O-ring grease application.**
- **REPORT BACK TO RPRB? No**
- **ACTIONEE: Joints and Seals Design and Final Assembly Work Center.**

## S&A DISASSEMBLY REPORT

---

- **PFARs:** 360T004B-25, 360L006A-31, 360L006B-32, 360L007A-19, 360L007B-20, TEM04-06, LAT41-03
  
- **DESCRIPTION:**
  - Circumferential galling was found on the shoulder seal surface of the S&A-to-adapter and B-B bore leak test (MS9902-01) plugs. The width and length of the galled region varies.
  
- **HISTORY:** Not previously reported.
  
- **DISCUSSION:**
  - Galling on the plug occurs during the machining process of the seal surface on the plug.
  
  - The leak test plugs are inspected and installed into the B-B at E-VAD. They are removed prior to leak test and re-installed on plant (B-B bore) and at KSC (flange).
  
  - Thiokol assembly planning does not call out inspection of the B-B bore leak test plug prior to re-installation.

*Thiokol* CORPORATION  
SPACE OPERATIONS

# S&A DISASSEMBLY REPORT

---

- **RECOMMENDATIONS:**

- **TEAM CLASSIFICATION: Minor Anomaly**

- **JUSTIFICATION:**

- **Violates surface finish and requires corrective action.**
    - **Shoulder seal is a packing rather than a face seal.**
    - **Galled surface does not extend across the full O-ring footprint.**
    - **No O-ring damage has been found due to galled shoulder seal surface of leak test plug.**

- **CORRECTIVE ACTION:**

- **Short Term: Inspect all MS9902-01 plugs in Stores and at E-VAD per MS9902 specification and reject those that are unacceptable.  
Effective: 19 January 1990.**

*Thiokol* CORPORATION  
SPACE OPERATIONS

# S&A DISASSEMBLY REPORT

---

- **CORRECTIVE ACTION (cont.):**
  - **Long Term: Replace MS9902-01 plug with 1U50159 leak test plug; 1U50159 plugs are 100 percent inspected and controlled in-house.**
- **REPORT BACK TO RPRB? No**
- **ACTIONEE: Quality Engineering for short term and S&A Component Team for long term.**

# S&A DISASSEMBLY REPORT

---

- **PFARs:** LAT41-01, TEM04-05.
- **DESCRIPTION:**
  - A single radial scratch was found across the shoulder seal surface of the S&A-to-adapter and B-B bore leak test (MS9902-01) plugs.
- **HISTORY:** Previously found on Second and Third Flights.
- **DISCUSSION:**
  - The assembly/leak test procedure for the S&A requires that the leak test plug be removed from the port prior to leak test of the seals. The old O-ring is to be removed from the plug. A new O-ring is to be installed onto the plug prior to plug re-installation.
  - Up to, but not including Fifth Flight, the tool used to remove the O-rings was causing the scratch across the seal surface of the plug.
    - Inspection of the seal surface was not being properly performed prior to plug re-installation.

*Thiokol* CORPORATION  
SPACE OPERATIONS



# S&A DISASSEMBLY REPORT

---

- **DISCUSSION (cont.):**
  - **PFAR's from Second and Third Flights were closed out by updating planning and using non-metallic removal tool for O-rings.**
  - **Corrective action became effective for Fifth Flight.**
- **RECOMMENDATIONS:**
  - **TEAM CLASSIFICATION: Minor Anomaly**
  - **JUSTIFICATION:**
    - **Violates PEEL; assembly metal damage is reportable.**
    - **No O-ring damage has been found due to scratch on plug.**
    - **Shoulder O-ring is a packing seal.**
    - **High installation torque ensures metal-to-metal seating of plug to port spotface.**

# S&A DISASSEMBLY REPORT

---

- **CORRECTIVE ACTION:**
  - **SHORT TERM: Modify vendor and Thiokol planning to properly inspect leak test plug seal surface prior to plug installation.  
Effective: 19 January 1990.**
- **REPORT BACK TO RPRB? No**
- **ACTIONEE: Quality Engineering and Joints and Seals Design**

*Thiokol* CORPORATION  
SPACE OPERATIONS

# S&A DISASSEMBLY REPORT

---

- **PFARs:** 360L006A-21
- **DESCRIPTION:**
  - The last thread of the S&A-to-adapter and B-B bore leak test (MS9902-01) plugs was chipped.
- **HISTORY:** Not previously reported.
- **DISCUSSION:**
  - The thread becomes chipped during the machining process; a portion of the thread shears off.
  - The MS9902-01 leak test plugs are lot accepted.
  - The chipped thread could damage the O-ring upon assembly.
    - The Thiokol assembly planning does not require the use of a thread protector to install the O-ring onto the plug.

*Thiokol* CORPORATION  
SPACE OPERATIONS

# S&A DISASSEMBLY REPORT

---

- **RECOMMENDATIONS:**

- **TEAM CLASSIFICATION: Minor Anomaly**

- **JUSTIFICATION:**

- This is the first time a chipped thread on a (MS9902) leak test plug has been reported.
- Requires corrective action.
- No O-ring damage has been found due to chipped thread.

- **CORRECTIVE ACTION:**

- **Short Term: Inspect all MS9902-01 plugs in Stores and at E-VAD per MS9902 specification and reject those that are unacceptable.**
  - **Implement thread protector. Effective: 19 January 1990.**

*Thiokol* CORPORATION  
SPACE OPERATIONS

## S&A DISASSEMBLY REPORT

---

- **CORRECTIVE ACTION (cont.)**
  - **Long Term: Replace MS9902-01 plug with 1U50159 leak test plug; 1U50159 plugs are 100 percent inspected and controlled in-house.**
  - **Add PEEL criteria stating chipped threads are reportable.**
- **REPORT BACK TO RPRB? No**
- **ACTIONEE: Quality Engineering for short term and S&A Component Team for long term.**

# S&A DISASSEMBLY REPORT

---

- **PFARs:** 360L007A-22, 360L007B-23
  
- **DESCRIPTION:**
  - A single circumferential scratch was found on the shoulder seal area of the S&A-to-adapter and B-B bore leak test ports.
  
- **HISTORY:** Not previously reported.
  
- **DISCUSSION:**
  - The scratch occurred prior to leak test plug installation. The scratch is visible with good lighting and should have been found during inspection.
  
  - Thiokol assembly planning does not call out an inspection point for the B-B bore leak test plug port seal surfaces.
  
  - The Barrier Booster refurbishment specification (STW7-3133) does not allow any seal surface defects.

# S&A DISASSEMBLY REPORT

---

- **RECOMMENDATIONS:**

- **TEAM CLASSIFICATION: Minor Anomaly**

- **JUSTIFICATION:**

- **Violates engineering and requires corrective action.**
    - **The scratch is in the circumferential direction and does not cross the O-ring footprint.**
    - **The shoulder O-ring is a packing seal.**
    - **No O-ring damage has been found due to scratch in leak test port.**

- **CORRECTIVE ACTION:**

- **Short Term: Update Thiokol assembly planning and vendor refurb planning to perform detailed inspection of all port seal surfaces. Effective: 19 January 1990.**

# S&A DISASSEMBLY REPORT

---

- **CORRECTIVE ACTION (cont.):**
  - **Long Term: Modify refurbishment specification, STW7-3133, to incorporate better seal surface definitions and inspection points.**
- **REPORT BACK TO RPRB? No**
- **ACTIONEE: S&A Component Team and Joints and Seals Design.**



## S&A DISASSEMBLY REPORT

---

- **PFARs:** 360L006A-31, 360L007B-21
- **DESCRIPTION:**
  - A black substance was found in the grease on the primary seal surface of the SII port.
- **HISTORY:** Not previously reported.
- **DISCUSSION:**
  - Lab analysis identified black substance as combustion products from SII.
  - Source of contamination was found to be introduced during removal of the SII at disassembly.
    - Combustion products in the sooted tip of the SII rubbed off into the grease as the SII was removed.

# S&A DISASSEMBLY REPORT

---

- **RECOMMENDATIONS:**
  - **TEAM CLASSIFICATION:** Remains observation.
  - **JUSTIFICATION:**
    - Non-problem and does not require corrective action.
  - **RECOMMENDATIONS:**
    - Close PFARs.

# S&A DISASSEMBLY REPORT

---

- **PFARs:** 360L006A-19, 360L006B-20, TEM04-08, TEM04-10
- **DESCRIPTION:**
  - **NSI/SII thread was found to continue into the primary seal surface.**
- **HISTORY:** Previously found on NSI/SII's all the way back into the SRM program.
- **DISCUSSION:**
  - **The NSI/SII is a NASA controlled part; the drawing does not control the thread termination point.**
    - **An industry alert was submitted in January 1989 stating that the threads may possibly continue up to the body and leave no viable seal surface. A recommendation for a specification change was made.**
      - **The alert was stopped by NASA.**
- **RECOMMENDATIONS:**
  - **TEAM CLASSIFICATION: Minor Anomaly**

*Thiokol* CORPORATION  
SPACE OPERATIONS

# S&A DISASSEMBLY REPORT

---

- **JUSTIFICATION:**
  - **Potential to violate seal surface and requires corrective action.**
  - **No history of thread continuation past O-ring footprint; two other seal surfaces remain.**
  - **SII's are low pressure leak tested; no leaks were detected.**
  - **No primary O-ring damage has been found due to thread continuation.**
  
- **CORRECTIVE ACTION:**
  - **Short Term: Inspect all SII's in Stores for continuation of threads.**
    - **Update planning to inspect for continuation of threads into seal surface prior to installation.**  
**Effective: 19 January 1990.**

# S&A DISASSEMBLY REPORT

---

- **CORRECTIVE ACTION (cont.):**
  - **Long Term: Recommend and submit engineering changes for a unibody SII, including industry standard thread relief, to NASA.**
  - **Add PEEL limits stating threads continuing into seal surface is reportable.**
- **REPORT BACK TO RPRB? No**
- **ACTIONEE: S&A Component Team and Joints and Seals Design.**

# S&A DISASSEMBLY REPORT

---

- **PFARs:** 360L006A-27, 360L006B-28
- **DESCRIPTION:**
  - A single radial scratch was found across the primary (shoulder) seal surface of the SII port.
- **HISTORY:** Not previously reported.
- **DISCUSSION:**
  - The scratch occurred prior to SII installation. The scratch is visible with good lighting and should have been found during inspection.
  - Thiokol assembly planning does not call out an inspection point for the SII port seal surfaces.
  - The Barrier Booster refurbishment specification (STW7-3133) does not allow primary seal surface defects.
- **RECOMMENDATIONS:**
  - **TEAM CLASSIFICATION:** Minor Anomaly

*Thiokol* CORPORATION  
SPACE OPERATIONS

# S&A DISASSEMBLY REPORT

---

- **JUSTIFICATION:**
  - Violates engineering and requires corrective action.
  - The SII's are low pressure leak tested; no leaks were detected.
  - The primary O-ring is a packing seal.
  - Evidence of soot to the primary O-ring has not been reported.
  - No O-ring damage has been found due to scratch in port.
  
- **CORRECTIVE ACTION:**
  - Short Term: Update Thiokol assembly planning and vendor refurb planning to include detailed inspection of all port seal surfaces. Effective: 19 January 1990.

# S&A DISASSEMBLY REPORT

---

- **CORRECTIVE ACTION (cont.):**
  - **Long Term: Update refurbishment specification, STW7-3133, to incorporate better seal surface definitions and inspection points.**
  - **Incorporate test plan to evaluate the SII leak test.**
- **REPORT BACK TO RPRB? No**
- **ACTIONEE: S&A Component Team and Joints and Seals Design.**



## S&A DISASSEMBLY REPORT

---

- **PFARs:** 360H005A-22, 360H005A-23, 360H005B-24, 360H005B-25, 360L006A-17, 360L006B-18, 360L007A-15, 360L007B-16, TEM04-07, TEM04-08
  
- **DESCRIPTION:**
  - Several deformations were found in the sealing washer on the SII's. The deformations are circumferential and follow the pattern of the NSI. The largest deformations, located over the wrench slots, are approximately 3 mils deep.
  
- **HISTORY:** Previously found at post-fire inspection since TEM-04. Deformations have been noticed since SII Lot HWD and subsequent.
  
- **DISCUSSION:**
  - The NSI/SII is a government furnished part.
    - The SII is created by welding a back-up ring to the NSI which provides a secondary seal surface. A sealing washer is then welded on to provide the actual seal surface and to compensate for irregularity in the NSI/back-up ring interface.
  
  - The washer is deformed during manufacturing process.

*Thiokol* CORPORATION  
SPACE OPERATIONS

# S&A DISASSEMBLY REPORT

---

## ■ RECOMMENDATIONS:

- **TEAM CLASSIFICATION: Minor Anomaly**
- **JUSTIFICATION:**
  - **Potential to violate O-ring squeeze and requires corrective action.**
  - **Deformation does not completely compromise secondary O-ring footprint.**
  - **The SII's are low pressure leak tested; no leaks were detected.**
- **CORRECTIVE ACTION:**
  - **Short Term: Investigate engineering accept/reject criteria of deformations.**
  - **Add inspection point during acceptance to screen out-of-tolerance deformations. Effective: 19 January 1990.**

*Thiokol* CORPORATION  
SPACE OPERATIONS

# S&A DISASSEMBLY REPORT

---

- **CORRECTIVE ACTION (cont.):**
  - **Long Term: Recommend and submit engineering changes to NASA for a unibody construction for the SII.**
  - **Add PEEL limits stating that deformations in sealing washer are reportable.**
  - **Evaluate new design for larger secondary O-ring and groove for higher squeeze.**
  - **Incorporate test plan to evaluate the SII leak test.**
- **REPORT BACK TO RPRB? Yes**
- **ACTIONEE: NASA, S&A Component Team, and Joints and Seals Design.**

# S&A DISASSEMBLY REPORT

---

- **PFARs:** 360L006A-25, 360L007B-18
- **DESCRIPTION:**
  - A single radial scratch was found across the sealing washer of the SII. The maximum depth of the worst case scratch was less than 1.0 mil.
- **HISTORY:** Not previously reported.
- **DISCUSSION:**
  - Thiokol assembly planning has an inspection point to verify no damage to the SII's: no scratches, nicks, dings, etc.
  - The scratches occur prior to SII assembly; source is unknown.
- **RECOMMENDATIONS:**
  - **TEAM CLASSIFICATION:** Minor Anomaly

*Thiokol* CORPORATION  
SPACE OPERATIONS

# S&A DISASSEMBLY REPORT

---

- **JUSTIFICATION:**
  - First time occurrence, is reportable, and requires corrective action.
  - The SII's are low pressure leak tested; no leaks were detected.
  - No secondary O-ring damage has been found due to the scratch across the seal washer.
- **CORRECTIVE ACTION:**
  - Short Term: Update Thiokol assembly log to include detailed inspection of SII seal surfaces; replace those that are unacceptable. Effective: 19 January 1990.
  - Long Term: Recommend and submit engineering changes to NASA for unibody SII.
  - Incorporate test plan to evaluate the SII leak test.
- **REPORT BACK TO RPRB? No**
- **ACTIONEE: S&A Component Team, Joints and Seals Design, and NASA.**

*Thiokol* CORPORATION  
SPACE OPERATIONS

## S&A DISASSEMBLY REPORT

---

- **PFARs:** 360L006A-26, 360L007A-17
  
- **DESCRIPTION:**
  - A single radial scratch was found across the bottom of the SII secondary O-ring groove.
  
- **HISTORY:** Not previously reported.
  
- **DISCUSSION:**
  - The scratch occurred prior to SII installation. The scratch is visible in good lighting and should not have been missed during inspection.
  
  - Thiokol assembly planning does not call out an inspection point for the SII port seal surfaces.
  
  - The Barrier Booster refurbishment specification (STW7-3133) does not allow secondary seal surface defects in ports.

# S&A DISASSEMBLY REPORT

---

- **RECOMMENDATIONS:**
  - **TEAM CLASSIFICATION: Minor Anomaly**
  - **JUSTIFICATION:**
    - Violates engineering and requires corrective action.
    - The SII's are low pressure leak tested; no leaks were detected.
    - No primary O-ring damage has been found due to scratch in shoulder seal surface of port.
  - **CORRECTIVE ACTION:**
    - Short Term: Update Thiokol assembly planning and vendor refurb planning to perform detailed inspection of all port seal surfaces. Effective: 19 January 1990.

# S&A DISASSEMBLY REPORT

---

- **CORRECTIVE ACTION (cont.):**
  - **Long Term: Update refurbishment specification, STW7-3133, to incorporate better seal surface definitions and inspection points.**
  - **Incorporate test plan to evaluate the SII leak test.**
- **REPORT BACK TO RPRB? No**
- **ACTIONEE: S&A Component Team and Joints and Seals Design.**



---

**RPRB PRESENTATION**

**POST-FIRE ANOMALIES**  
**SEALS COMPONENT REPORT**  
**TEAM RECOMMENDATIONS**

**DAVID GURNEY**

**14 FEBRUARY 1990**

**Coordinated With:**

**PM - Gregg Kotter, Marcel Keanaaina**  
**SIE - Kelly Kobayashi, James Seiler**  
**DE - Reo Mackley, Kelly Baker**  
**QE - Loren Robison, Karl Shupe**  
**PFP - Dave Starrett, Lon Hyer**  
**REL - Marlin Loosle**

*Thiokol* CORPORATION  
SPACE OPERATIONS

INFORMATION ON THIS PAGE WAS PREPARED TO SUPPORT AN ORAL PRESENTATION  
AND CANNOT BE CONSIDERED COMPLETE WITHOUT THE ORAL DISCUSSION

# POST FIRE ANOMALIES

---

- PFARs: 360L003A-20, 360L003B-21, 360T004A-22, 360T004B-23, 360H005A-27, 360H005B-28, 360L006A-35, 360L006B-36
  
- DESCRIPTION:
  - No grease on port, plug, and O-ring
  
- HISTORY:
  - Similar problems previously reported to RPRB on 18 April 1989
  
  - Corrective actions implemented:
    - Planning has been updated to include greasing, but will not become totally effective until 10th flight.
  
    - Drawings have been changed to call out the proper installation specification.
  
  - Previously classified as Minor Anomaly

*Thiokol* CORPORATION  
SPACE OPERATIONS

# POST FIRE ANOMALIES

---

- **RECOMMENDATIONS:**
  - **TEAM CLASSIFICATION:** Minor Anomaly
  - **JUSTIFICATION:**
    - Violates engineering, does not require any new corrective action, and has no impact on motor performance because:
      - The O-ring will seal properly with no grease
      - The plugs are verified to be flush with the case
      - Does not reduce usability of plug for its intended function.
  - **CLOSE ALL PFARs**
  - **CORRECTIVE ACTION:** Already implemented, no additional action required.
  - **REPORT BACK TO RPRB?** No

*Thiokol* CORPORATION  
SPACE OPERATIONS

## POST FIRE ANOMALIES

---

- PFARs: 360L001B-50, 360L002A-34, 360L002A-35, 360L002B-33, 360L003A-18, 360L003B-19, 360T004A-26, 360T004B-20, 360L004B-21, 360L005A-23, 360L005B-24, 360L006B-24, 360L007A-28
  
- DESCRIPTION:
  - Rolled threads on last partial thread of 1U51475 & 1U100269 leak check plugs
  
- HISTORY:
  - Occurred on RSRM-1, and RSRM-2 for the 1U100269 plug and was reported to RPRB on 1 March 1989.

*Thiokol* CORPORATION  
SPACE OPERATIONS

# POST FIRE ANOMALIES

---

- Corrective actions (Completed) were to:
  - Inspect plugs in house for rolled threads
  - Discuss problems with the vendor to correct the problems on future hardware.
  - Release ECO to prohibit rolled threads
  - Complete the implementation of O-ring installation aid and plug thread inspection in Shop Planning
- DISCUSSION:
  - O-ring cannot be damaged during assembly because it is assembled over the O-ring installation aid.
  - Once installed, the O-ring will not contact the threads of the plugs.
  - During disassembly, the O-ring is typically cut on the inner diameter as the plug rotates out.

*Thiokol* CORPORATION  
SPACE OPERATIONS

# POST FIRE ANOMALIES

---

- **RECOMMENDATIONS:**
  - **TEAM CLASSIFICATION:** Remains Observation
  - **JUSTIFICATION:**
    - This problem does not require any new corrective action.
    - The O-ring will not be damaged on assembly.
    - This will not affect the installation of the plug
  - **CORRECTIVE ACTION:** Joints and Seals/Post Fire Evaluation to update the peel document to allow this situation on disassembly.
  - **CLOSE PFARs**
  - **REPORT BACK TO RPRB?** No

## POST FIRE ANOMALIES

---

- **PFARs:** 360H005B-25, 360L006B-22, 360L007A-27
  
- **DESCRIPTION:**
  - Radial scratches on the secondary seal surface of leak check plugs (1U51475 & 1U100269)
  
- **DISCUSSION**
  - Source of the scratch is believed to be handling damage after the inspection of the plugs.
  
  - The 1U51475-01 plugs are made from a 1U100269-01 plug.
  
  - A baseline now controls the handling and processing of the 1U100269 plugs.

*Thiokol* CORPORATION  
SPACE OPERATIONS

# POST FIRE ANOMALIES

---

- **RECOMMENDATIONS**

- **TEAM CLASSIFICATION:** Minor Anomaly

- **JUSTIFICATION:**

- Violates engineering and requires corrective action.

- Potential leak path

- Potential damage to O-ring, causing leak path

- **CORRECTIVE ACTION:** Program Management to write an AO to inspect plugs in house for this defect that were made after the last inspection, and before the baseline was established. Quality Engineering to write the planning for this inspection. Quality Engineering to take steps to prevent future occurrences of this problem.

- **REPORT BACK TO RPRB?** No

*Thiokol* CORPORATION  
SPACE OPERATIONS



## POST FIRE ANOMALIES

---

- PFARs: 360H005A-26
  - DESCRIPTION:
    - Circumferential scratch on dovetail of adjustable vent port plug (1U76425)
  - DISCUSSION:
    - The scratch is a machining mark.
  - HISTORY
    - First occurrence of this problem

*Thiokol* CORPORATION  
SPACE OPERATIONS

# POST FIRE ANOMALIES

---

- **RECOMMENDATIONS**
  - **TEAM CLASSIFICATION: Minor Anomaly**
  - **JUSTIFICATION:**
    - **Violates engineering and requires corrective action.**
    - **Scratch is circumferential, and does not go across the footprint of the O-ring.**
    - **The O-ring in this area is a packing seal, and will tolerate this type of defect.**
    - **The O-rings of this plug are leak tested.**
    - **Circumferential tooling marks are allowed on the mating surface.**
    - **No structural concerns**

*Thiokol* CORPORATION  
SPACE OPERATIONS

## POST FIRE ANOMALIES

---

- **CORRECTIVE ACTION:** Quality Engineering to train inspectors to find this problem.
- **REPORT BACK TO RPRB?** No

*Thiokol* CORPORATION  
SPACE OPERATIONS

## POST FIRE ANOMALIES

---

- **PFARs: 360H005B-32**
  - **DESCRIPTION:**
    - **Raised metal in the first internal thread of the Adjustable Vent Port Plug (1U76425-03).**
  - **DISCUSSION:**
    - **The raised metal is believed to have been caused by slightly cross threading either the leak test adapter or Closure Plug into these threads.**
  - **HISTORY**
    - **First occurrence of this problem**

*Thiokol* CORPORATION  
SPACE OPERATIONS

# POST FIRE ANOMALIES

---

- **RECOMMENDATIONS**
  - **TEAM CLASSIFICATION:** Minor Anomaly
  - **JUSTIFICATION:**
    - The Closure Plug is verified to be flush at installation.
    - Running and final torque values controlled
    - Threads are inspected prior to installation of the Closure Plug.
  - **CORRECTIVE ACTION:** Quality Engineering to train inspectors to find this problem.
  - **REPORT BACK TO RPRB?** No