

E5687

NASA Technical Memorandum 103256

# ATDRS Payload Technology R & D

G. Anzic, D.J. Connolly, G. Fujikawa,  
M. Andro, R.R. Kunath, and G.R. Sharp  
*Lewis Research Center  
Cleveland, Ohio*

Prepared for  
GLOBECOM '90, IEEE Global Telecommunications Conference  
sponsored by the IEEE Communications Society  
San Diego, California, December 2-5, 1990

**NASA**

## ATDRS PAYLOAD TECHNOLOGY R & D

G. Anzic, D.J. Connolly, G. Fujikawa, M. Andro, R.R. Kunath, and G.R. Sharp

National Aeronautics and Space Administration  
Lewis Research Center  
Cleveland, Ohio 44135

### Summary

Lewis Research Center is conducting four technology development tasks which were chosen to reduce (or at least better understand) the technology risks associated with proposed approaches to Advanced Tracking and Data Relay Satellite (ATDRS). We report, on this work, to the ATDRS Project Office at Goddard Space Flight Center. The four tasks relate to a Tri-Band Antenna feed system, a Digital Beamforming System for the S Band Multiple Access System (SMA), an SMA Phased Array Antenna, and a Configuration Thermal/Mechanical Analysis task. The objective, approach, and status of each task will be discussed.

### Introduction

Proposed approaches to ATDRS include several significant technology advances as compared to the current generation of Tracking and Data Relay Satellite (TDRS). These technologies will undoubtedly be discussed in detail by other authors at this conference. Lewis Research Center has agreed to conduct technology development tasks which are directed toward minimizing the technology risk which will ultimately be assumed by the ATDRS program. The four tasks we are conducting are described below:

Tri-Band Feed: To design, develop, and test a Tri-Band Feed (S, Ku, Ka) consisting of a phased array feed, frequency selective surfaces, and a reflector.

Digital Beamforming System: To design, develop, and test an SMA phased array antenna system which uses digital techniques at IF to form the beam.

SMA Phased Array Antenna: To design and develop a seven element microstrip array antenna and characterize the array and subarray elements.

Spacecraft Configuration Studies: To determine the configuration impact of introducing offset fed antennas to ATDRS and to assess the thermal implications of patch array antennas on ATDRS.

This report contains a section addressing each task.

### Tri-Band Antenna Feed Development

Future requirements for the ATDRS will include the addition of Ka-band service for the single access (SA) antennas. A key objective is the design and development of a feed system which will allow three frequency bands (S, Ku, and Ka) to be used with a single reflector antenna. This presents a challenging problem to the antenna system designer. Studies are now underway to develop a tri-band antenna feed system which is intended to verify some of the concepts required by the SA antennas. Two cooperative research agreements with the NASA Lewis are investigating these critical areas; one with the University of Illinois, Urbana-Champaign, IL and another with Ohio State University, Columbus, OH.\*

In order to solve the problem of a tri-band antenna feed system, one must first consider the feed configuration in question. As shown in figure 1, it is infeasible to develop a single horn to feed the three frequency bands to a single reflector. A more realistic, but challenging, method is to employ the use of subreflectors and frequency selective surfaces (FSS) to feed the antenna. One antenna design which is being studied for the SA antenna application is shown in figure 2. This configuration uses three separate horns for each of the three frequency bands and two FSS to illuminate a 3.8 m parabolic reflector. Existing TDRS spacecraft employ 4.9 m mesh reflectors in the SA antenna system. From our reflector size studies, it was concluded that the reflector size is primarily determined by the S-band receiving gain of about 36 dB. The losses associated with the offset antenna design of figure 2 lead to a calculated efficiency of 60 percent. This will allow for a size reduction of the reflector from the current 4.9 m mesh-type to 3.8 m. By implementing a smaller, solid reflector, lower cost and better rf efficiency can be achieved. Another key to the success of this approach is the design of the frequency selective surfaces. The important criteria for

\*NASA Cooperative Agreements NCC3-156 and NCC3-158, NASA Lewis Research Center, Cleveland, OH.

the FSS are the proper selection of the elements for use with circular polarization, low loss, wide bandwidth, and lightweight design. As an example, for the frequency selective surfaces employed in the design of figure 2, the larger surface requires the properties to reject Ku-band frequencies, while allowing transmission of both S- and Ka-band frequencies. The surface closest to the S-band horn similarly must reject Ka-band frequencies, while allowing passage of S-band frequencies. These state-of-the-art FSS designs need to be analyzed and optimized using rigorous computer codes. Several other FSS designs are being investigated for this and other antenna configurations. One design of a dichroic surface that is reflective in both Ku and Ka band, while transparent in S-band is being studied in detail. This surface uses two layers made of resonating dipoles spaced accordingly to obtain the aforementioned rf properties. Furthermore, to stabilize the nulls which occur with varying angle of incidence, dielectric matching plates are also employed. Calculations of dielectric and conductor losses are being done as well. Fabrication and testing of various FSS designs and a comparison of experimental and theoretical data is forthcoming. Other offset and symmetrical antenna configurations are also being studied.

Planned for future experiments is an experimental antenna package which will incorporate a tri-band antenna feed assembly, consisting of feed horns, frequency selective surfaces, and a 2.7 m precision reflector. This package will be assembled, integrated and tested as a complete tri-band antenna system.

#### Digital Beamforming Development

The Digital Beamforming development effort is a hardware simulation testbed for the investigation and evaluation of digital beamforming with direct application to the ATDRS S band multiple access (SMA) system. This testbed development, as shown in figure 3, consists of the following major subsystems: the BER Measurement System (BMS) which provides digital and modulated data sources that drive the system, the Phased Array Simulator (PAS) used to simulate a seven element patch array antenna, the Digital Beamforming Processor (DBFP) that digitally processes and combines the seven input channels, and the Test and Control Computer (TCC) which provides testbed control during testing. The entire system is designed to be programmable to facilitate performance measurements under varying distortions and interference scenarios.

Three simulated user signals are generated by the BMS for input into the PAS/DBFP subsystems, and after processing, a single desired channel is demodulated for BER measurements. The BMS provides one desired user signal and two interferer signals at uncoded data rates from 100 KHz to 2.048 MHz in QPSK or BPSK modulation formats. Additionally, a spread spectrum modem with a 2.048 chip rate can be manually configured into the system. Pseudorandom data is generated

for each of the three channels, but only one channel is received and checked for errors. The three user signals from the BMS are downconverted to 20 MHz IF and output to the PAS for further processing.

To simulate three user beams arriving at programmable receive angles, programmable phase shifters and associated RF hardware in the PAS combine two interferer signals and one desired data signal from the BER Measurement subsystem into seven phased array receive channels for digitization and processing by the Digital Beamforming Processor (DBFP). Each of the seven channels can be subjected to nonlinear distortions or additive white gaussian noise.

The seven received channels from the PAS are IF sampled at 16 MHz and digitally processed by the DBFP to extract the desired user signal. A single analog to digital converter is used to sample the input signal, after which it is digitally mixed and filtered to baseband generating in phase and quadrature samples. The seven in phase and seven quadrature samples are weighted and then summed to create the desired user signal which is upconverted to 70 MHz IF and routed to the BMS for demodulation and bit error rate measurement.

Automated test and configuration of the testbed is under control of the TCC, a personal computer. The TCC will process user defined files containing test definition and configuration commands that will analyze DBP performance subject to the effects of noise, multiple interferers, nonlinear distortions and digital implementation effects of digital beamforming.

Future tests will be conducted with the PAS subsystem removed and substituted with an actual seven element phased array antenna. A near field antenna test facility will be used to measure performance of the combined phased array antenna and DBFP.

#### SMA Phased Array Investigations

The investigations into the SMA phased array include experimentation and demonstration of microstrip patch antennas, coplanar waveguide power distribution structures, and analysis of optimum phased array designs. These investigations will culminate in the demonstration of a 7 element SMA proof-of-feasibility phased array antenna. This antenna will also be used in a demonstration of the digital beamforming network discussed previously.

#### Microstrip Patch Antenna Investigations

The potential for light weight, low cost, and mechanically simple antenna elements, makes microstrip patch antennas an attractive alternative to the helical antenna elements used on the earlier TDRS spacecraft. However, the requirement that the elements be circularly polarized

and relatively wide bandwidth provides a challenging application for microstrip patch antennas. Microstrip patch antennas are inherently narrow bandwidth and low gain. Parasitic antenna element techniques will be used to alter these characteristics. The investigation involves the development of single, circularly polarized (CP) microstrip patch antennas first, and then the development of 7-patch elements.

Several techniques for generating CP using microstrip patch antennas have been previously demonstrated. Single point rf feeding is being utilized in this investigation to minimize the complexity of the rf distribution and microstrip patch antenna design. It is possible to excite simultaneous transverse electric fields across the patch with a single, carefully placed feed point. Early, nonoptimized configurations have demonstrated CP patches with 2 dB axial ratio. Feeding techniques using aperture coupling with crossed slots are also being considered.

Parasitic effects are being investigated to augment the gain and bandwidth features of both the single patches and the 7-patch elements. The configurations being investigated are 3-layer single patch designs, and then combining these together into 7-patch elements. Three 7-patch element configurations are being investigated. In one configuration the center patch is excited and the outer patches are parasitic, in the second configuration the outer patches are excited and the center patch is parasitic, and in the third configuration all of the patches are excited. An example of the 7-patch element is shown in figure 4.

#### Coplanar Waveguide Distribution Investigations

Coplanar waveguide distribution structures are being investigated because they provide a low insertion loss, light weight solution to the distribution of rf to the patches in the phased array elements. Two coplanar waveguide distribution configurations are presently being investigated. Figure 5 is an example of a 7-way, coplanar waveguide power divider/combiner. As can be seen from the data, the measured insertion loss is only 0.15 dB more than the 8.45 dB theoretically expected for a 7-way split. The other configuration is a 6-way power divider/combiner. These two designs will be used to feed rf to the 7-patch antenna element designs previously discussed.

#### Analytical Phased Array Design Investigations

Analytical modelling of the SMA phased array antenna is being used to identify optimum phased array antenna designs. The element size is relatively large as a result of using a 7-patch cluster to increase the element gain. The impact of this is an increase in the interelement spacing which can result in the formation of grating lobes. Grating lobes can also be the result of scanning the beam to the  $\pm 10^\circ$  ATDRS specification. The modelling code being developed is being used to define phased array configurations that minimize grating lobes.

The impact of antenna excitation tapering is also being modelled. The effects of amplitude and phase tapering of the elements in the phased array are being investigated. These effects can be used to modify the impact of grating and side-lobes. Further, the code's capability to model element excitations will be used with experimental measurements of the microstrip patch antennas fabricated, to empirically derive the impact of mutual coupling in microstrip patch antenna designs.

#### Proof-Of-Feasibility SMA Phased Array Antenna

The end-product of all of the investigations discussed will be the design, fabrication and testing of a 7-element proof-of-feasibility (POF) SMA phased array antenna. Seven 7-patch elements will be fabricated based upon the optimum 7-patch element design investigated. The elements will be rf fed by an optimized coplanar waveguide combiner. The entire antenna will be rf tested and characterized. Finally, the POF SMA phased array antenna will be interfaced with a digital beamforming network to evaluate the performance of the latter.

#### Spacecraft Configuration Studies

The basic offset fed parabolic antenna design has been previously described. The geometry of the spacecraft configuration is set by the requirements of the solid surface offset fed parabolic antennas, the requirement for a large scanning phased array and the desirability of reducing the size of the configuration in order to reduce launch costs. For this reason, a decision was made to attempt to design the spacecraft to be launched on an Atlas-Centaur using the 4.3 m nose fairing.

The inside dynamic envelope for the 4.3 m fairing is actually 3.7 m. It therefore, becomes necessary to fold both the 3.8 m diameter reflectors and to fold the arms holding the reflectors in order to reduce the size of the spacecraft for launch. Figure 6 shows the spacecraft in the launch configuration.

Figure 7 shows the spacecraft in the fully deployed orbital configuration. It is necessary to gimbal both offset fed antennas near the antenna feeds in order to meet the antenna beam pointing requirements of the spacecraft. It is planned that the rf power electronics equipment for both the Ka and Ku bands be mounted in the arms of the antennas as near as possible to the antenna feeds in order to reduce rf power losses and to avoid the transfer of these rf signals across the spacecraft body/antenna arm gimbal interface which would require wave-guide rotary joints. The S-band rf power could be transferred across the gimbal interface using flexible co-axial rf cable or rotary joints if needed.

The key to achieving success with this configuration is in finding gimbal gear motors capable of sluing the mass of the deployed antennas at the required angular velocities. The mass

of the antenna reflector would therefore need to be kept at a minimum. The other spacecraft systems requirement would be for momentum wheels of sufficient size to react the torque of the antennas when sluing. Designs for success in both these areas should be readily achievable.

A preliminary thermal analysis of the SMA antenna has been completed. The assumptions were that the SMA antenna was a flat plate perfectly insulated on the spacecraft side and painted with S-13GLO white paint on the side that faces the earth and that the transmitting electronic devices would have a heat dissipation of less than  $0.02 \text{ W/cm}^2$ . The results of the analysis indicated that when the SMA antenna is directly facing the sun, this heat dissipation would result in a maximum SMA temperature of less than  $100^\circ \text{C}$  at spacecraft end of life. Any operating SMA electronic devices would be closely

coupled to this temperature. Thus, additional SMA thermal control measures do not appear to be necessary at this time.

#### Concluding Remarks

Lewis Research Center is conducting four technology development tasks which were chosen to reduce (or at least better understand) the technology risks associated with proposed approaches to ATDRS. We report, on this work, to the ATDRS Project Office at Goddard Space Flight Center. The four tasks relate to a Tri-Band Antenna feed system, a Digital Beamforming System for the S Band Multiple Access System (SMA), an SMA Phased Array Antenna, and a Configuration Thermal/Mechanical Analysis task. The objective, approach, and status of each task has been described.

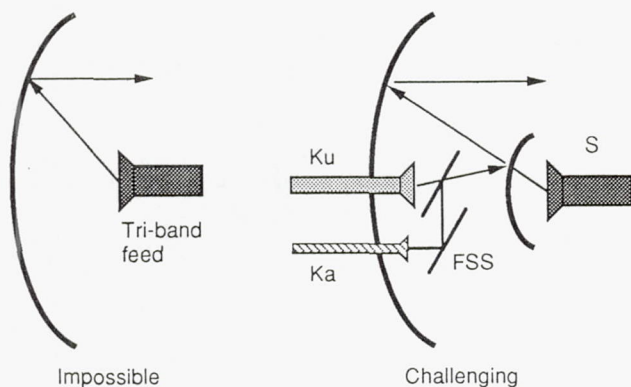

Figure 1.—Examples of tri-band antenna feed for ATDRS.

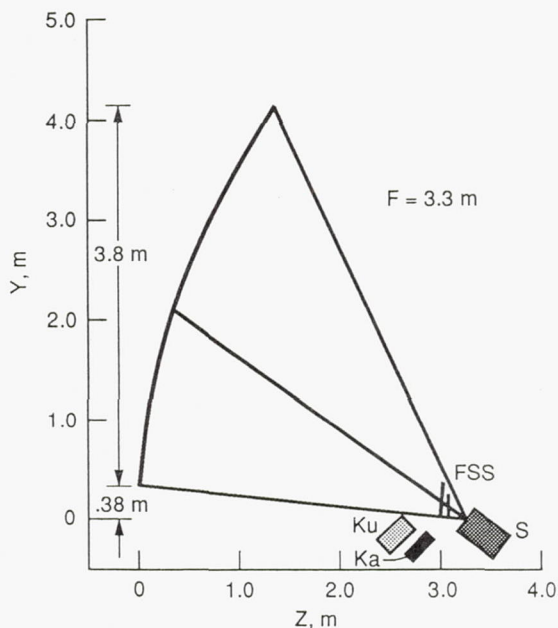

Figure 2.—Design of offset antenna configuration for single access antenna.

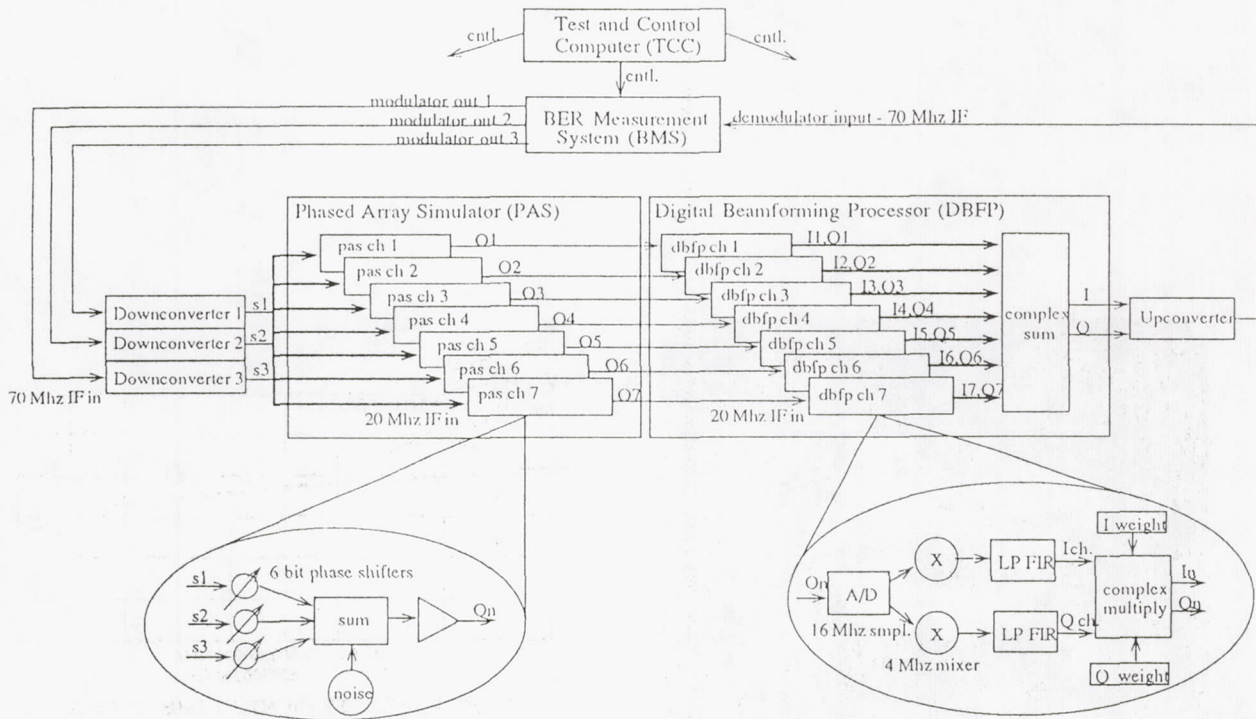

Figure 3.—Digital beamforming system.

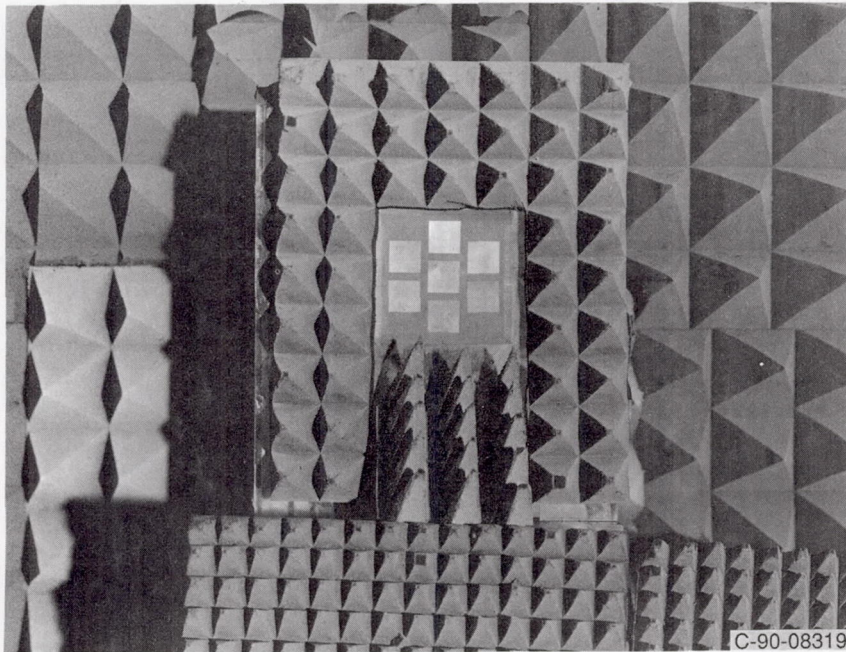

Figure 4.—7-Patch ATDRS microstrip element.

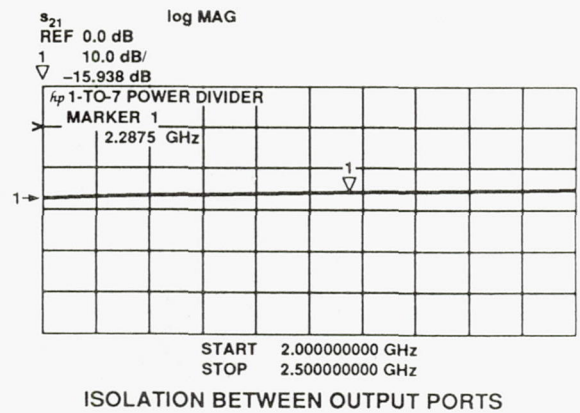
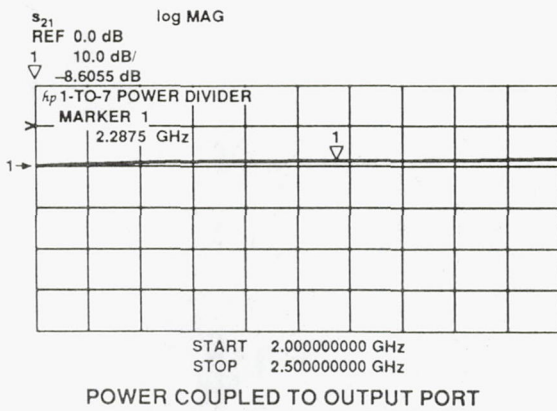
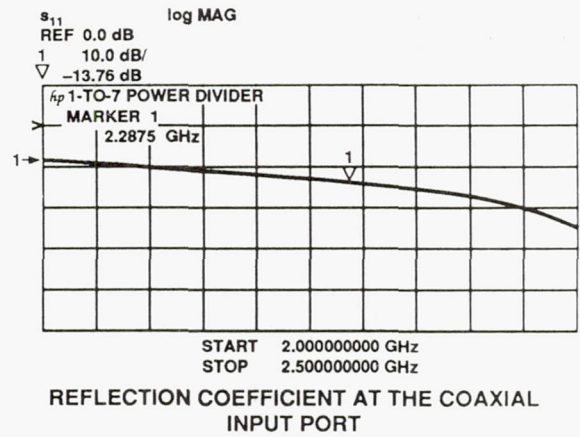
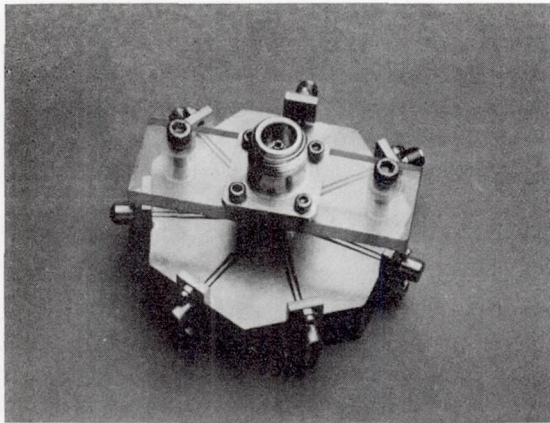

Figure 5.—Coplanar waveguide 1:7 power divider.

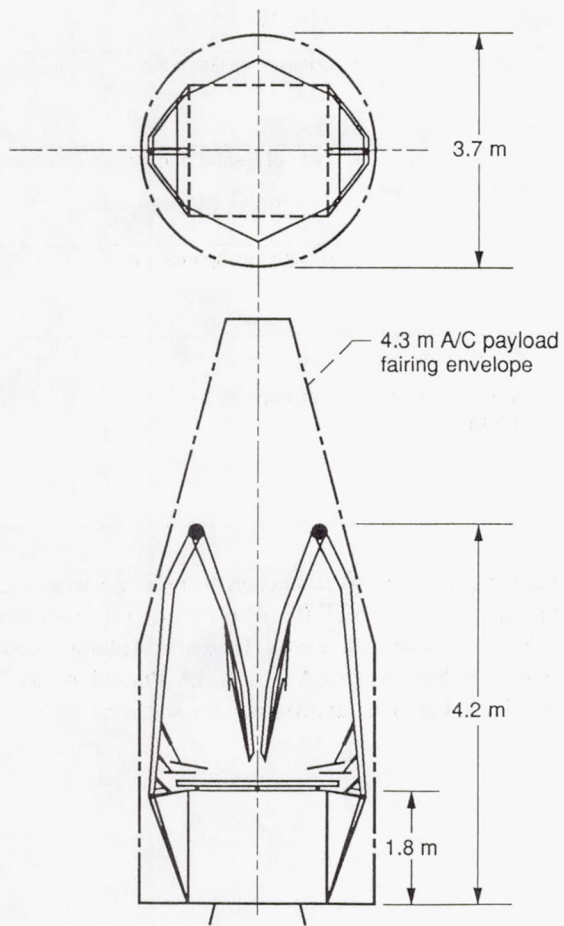

Figure 6.—Stowed ATDRS phased array and offset fed reflector configuration concept.

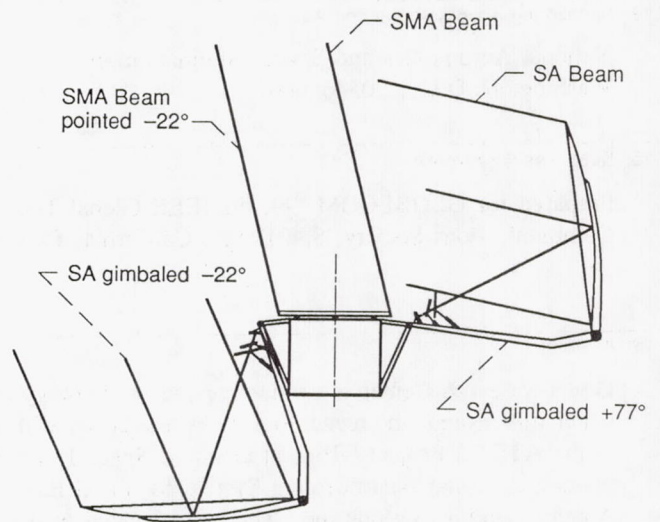

Figure 7.—ATDRS phased array and offset fed reflector configuration concept.



1. Report No. NASA TM-103256		2. Government Accession No.		3. Recipient's Catalog No.	
4. Title and Subtitle ATDRS Payload Technology R & D				5. Report Date	
				6. Performing Organization Code	
7. Author(s) G. Anzic, D.J. Connolly, G. Fujikawa, M. Andro, R.R. Kunath, and G.R. Sharp				8. Performing Organization Report No. E-5687	
				10. Work Unit No. 316-60-13	
9. Performing Organization Name and Address National Aeronautics and Space Administration Lewis Research Center Cleveland, Ohio 44135-3191				11. Contract or Grant No.	
				13. Type of Report and Period Covered Technical Memorandum	
12. Sponsoring Agency Name and Address National Aeronautics and Space Administration Washington, D.C. 20546-0001				14. Sponsoring Agency Code	
15. Supplementary Notes Prepared for GLOBECOM '90, the IEEE Global Telecommunications Conference sponsored by the IEEE Communications Society, San Diego, California, December 2-5, 1990.					
16. Abstract Lewis Research Center is conducting four technology development tasks which were chosen to reduce (or at least better understand) the technology risks associated with proposed approaches to ATDRS. We report, on this work, to the ATDRS Project Office at Goddard Space Flight Center. The four tasks relate to a Tri-Band Antenna feed system, a Digital Beamforming System for the S Band Multiple Access System (SMA), an SMA Phased Array Antenna, and a Configuration Thermal/Mechanical Analysis task. The objective, approach, and status of each task will be discussed.					
17. Key Words (Suggested by Author(s)) ATDRS Antenna technology Digital beam forming			18. Distribution Statement Unclassified - Unlimited Subject Category 18		
19. Security Classif. (of this report) Unclassified		20. Security Classif. (of this page) Unclassified		21. No. of pages 8	22. Price* A02