

GRANT

IN-20-CR

VIRGINIA POWER ELECTRONICS CENTER

**V
I
R
G
I
N
I
A

T
E
C
H**

THE BRADLEY DEPARTMENT OF ELECTRICAL ENGINEERING

278652

101 OVERRIDE

1268

**ANALYSIS AND DESIGN OF A
HIGH POWER, DIGITALLY-CONTROLLED
SPACECRAFT POWER SYSTEM**

SIX MONTH REPORT

**PREPARED FOR
NASA/GODDARD SPACE FLIGHT CENTER
GREENBELT, MD 20771
NAG5-1232**

**PREPARED BY
F.C. LEE AND B.H. CHO**

N91-11053

Unclas 0278652

CSCL 10B 63/20

(NASA-CR-186946) ANALYSIS AND DESIGN OF A
HIGH POWER, DIGITALLY-CONTROLLED SPACECRAFT
POWER SYSTEM Semiannual Report (Virginia
Polytechnic Inst. and State Univ.) 126 p

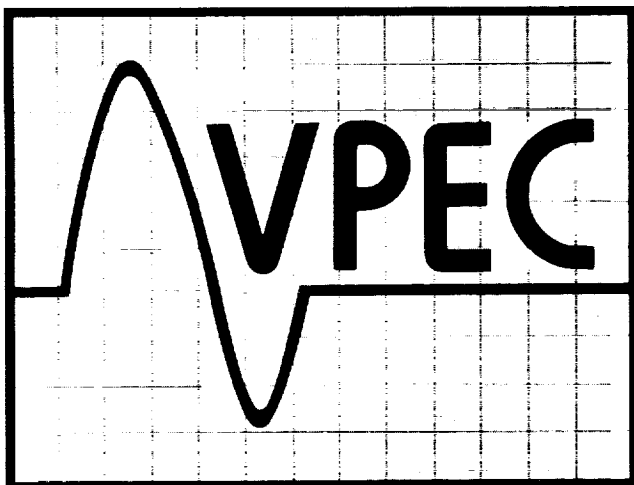

May 16, 1990

**VPEC IS A TECHNOLOGY
DEVELOPMENT CENTER
OF THE VIRGINIA
CENTER FOR
INNOVATIVE TECHNOLOGY**

VIRGINIA POLYTECHNIC INSTITUTE AND STATE UNIVERSITY

BLACKSBURG, VA. 24061-0111 (703) 231-4536

ACCESSIONING, REPRODUCTION AND DISTRIBUTION
BY OR FOR NASA PERMITTED



**ANALYSIS AND DESIGN OF A
HIGH POWER,
DIGITALLY-CONTROLLED
SPACECRAFT POWER SYSTEM**

SIX MONTH REPORT

**PREPARED FOR
NASA/GODDARD SPACE FLIGHT CENTER
GREENBELT, MD 20771
NAG5-1232**

**PREPARED BY
F.C. LEE and B.H. CHO**

May 16, 1990

**Copyright © 1990 Virginia Power Electronics Center.
All rights reserved.**

**ACCESSIONING, REPRODUCTION AND DISTRIBUTION
BY OR FOR NASA PERMITTED**

I. SUMMARY

This midterm report describes the progress to date on the Analysis and Design of a High Power, Digitally Controlled Spacecraft Power System. Two quarterly presentations have already been made to NASA Goddard. This report contains the presentation material as well as a summary of the accomplishments to date.

The Statement of Work is divided into two phases.

1. Phase I:

- Task 1. Battery Discharger Topology Trade-off

2. Phase II:

- Task 1. ORU Level Modeling and Control
- Task 2. DC Bus Regulation and Mode Control
- Task 3. Example Design of Digitally Controlled Spacecraft
- Task 4. Bus Performance Verification With Model

This report describes the progress on Phase 1, Task 1 and Phase 2 Tasks 1 and 2. The remaining two tasks have just been started.

II. Phase 1, Task 1: Battery Discharger Topology Trade-off

Several battery discharger topologies have been compared for use in the space platform application. The task originally called for a comparison of the following candidate topologies:

1. Boost Converter
2. Tapped-Boost Converter
3. Voltage-Fed Push-Pull with Auto-transformer
4. Current-Fed Push-Pull with Auto-transformer

Updated information has since been provided on the battery voltage specification. Initially it was thought to be in the 30 to 40 V range. It is now specified to be 53 V to 84 V. This eliminated the tapped-boost and the current-fed auto-transformer converters from consideration. After consultations with NASA, it was decided to trade-off the following topologies:

1. Boost Converter
2. Multi-Module, Multi-Phase Boost Converter
3. Voltage-Fed Push-Pull with Auto-transformer

A non-linear design optimization software tool developed by VPEC was employed to facilitate an objective comparison. Non-linear design optimization insures that the best design of each topology is compared.

The results indicate that a four-module, boost converter with each module operating 90 degrees out of phase is the optimum converter for the space platform.

Phase 2, Task 1 : ORU Level Modeling and Control

Large-signal and small-signal models have been generated for the shunt, charger, discharger, battery, and the mode controller. The models were first tested individually according to the space platform power system specifications supplied by NASA. The battery ORU model consists of the battery, charger, and discharger models integrated together. This model was used to investigate issues such as interfacing, control, and paralleling of ORU's.

The effect of battery voltage imbalance on parallel dischargers was investigated with respect to dc and small-signal responses. Similarly, the effects of paralleling dischargers and chargers were also investigated. A solar array and shunt model was included in these simulations. A model for the bus mode controller (power control unit) was also developed to interface the ORU model to the platform power system.

Phase 2, Task 2 : DC Bus Regulation and Mode Control

The small signal models were used to generate the bus impedance plots in the various operating modes. The large signal models were integrated into a system model, and time domain simulations were performed to verify bus regulation during mode transitions. Some changes have subsequently been incorporated into the models. The changes include the use of a four module boost discharger, and a new model for the mode controller, which includes the effects of saturation. The new simulations for the boost discharger show the improvement in bus ripple that can be achieved by phase-shifted operation of each of the boost modules.

**ANALYSIS AND DESIGN OF A HIGH POWER,
DIGITALLY CONTROLLED SPACECRAFT
POWER SYSTEM**

Quarterly Progress Review

for

**NASA Goddard Space Flight Center
Greenbelt, MD**

January 31, 1990

Prepared by

**D. Sable, A. Patil, T. Sizemore, B.H. Cho and F.C. Lee
Virginia Power Electronics Center
Virginia Polytechnic Institute
and State University
Blacksburg, Virginia 24061**

BATTERY DISCHARGER TOPOLOGY TRADEOFF STUDY

COMPARISON APPROACH

DESIGN SPECIFICATIONS

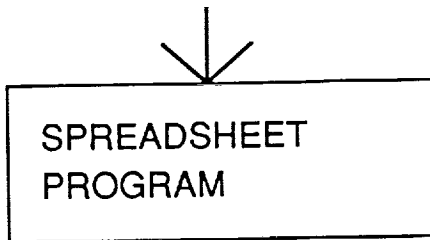

COMPONENT STRESSES

SELECTION OF POWER COMPONENTS

COMPONENT PARAMETERS

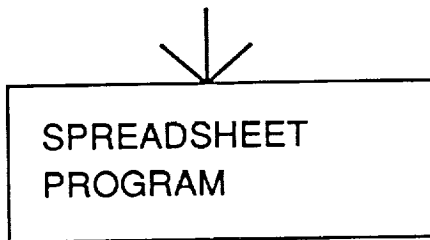

INITIAL DESIGN VALUES
INITIAL EFFICIENCY CALCULATION
INITIAL WEIGHT CALCULATION

MINIMUM
EFFICIENCY

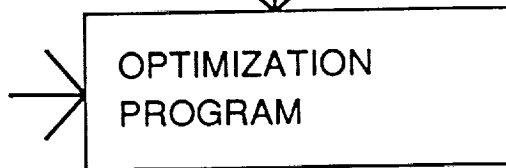

BEST DESIGN UNDER GIVEN CONSTRAINTS

BOOST CONVERTER CHARACTERISTICS

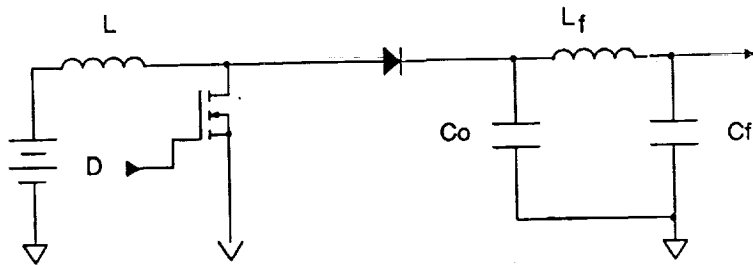

Boost Converter with Secondary Filter

SIMPLEST STEP-UP TOPOLOGY

1 SWITCH, 1 DIODE

NO TRANSFORMER

CONTINUOUS INPUT CURRENT

HIGH RMS CURRENT STRESS IN C_o

DIFFICULT CONTROL CHARACTERISTICS

MOVING POLES

RIGHT-HALF-PLANE ZERO

CIC NECESSARY TO OBTAIN GOOD PERFORMANCE

VFPPAT CONVERTER CHARACTERISTICS

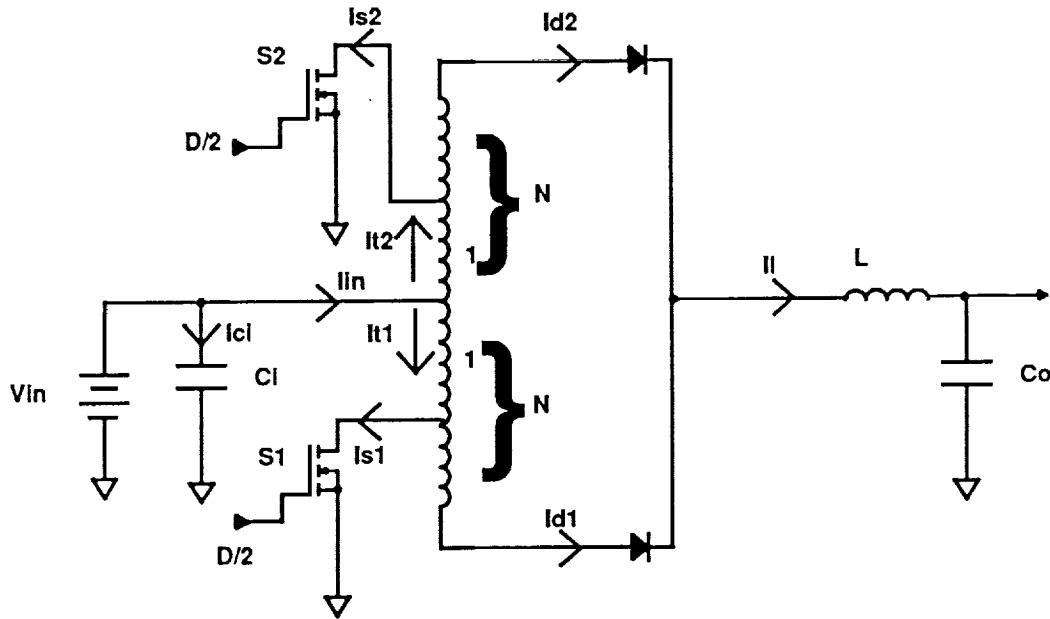

$$V_o/V_i = 1 + ND$$

BUCK-TYPE STEP-UP TOPOLOGY

2 SWITCHES, 2 DIODES

CONTINUOUS OUTPUT CURRENT

SEMI-CONTINUOUS INPUT CURRENT

HIGHER SWITCH AND DIODE VOLTAGE STRESS

SIMPLER CONTROL CHARACTERISTICS

CIC NECESSARY TO FLUX-BALANCE TRANSFORMER

LOW SWITCHING LOSS

POTENTIALLY HIGH LEAKAGE INDUCTANCE LOSS

VOLTAGE-FED, PUSH-PULL WITH TAPPED AUTOTRANSFORMER (VFPPAT) CONVERTER

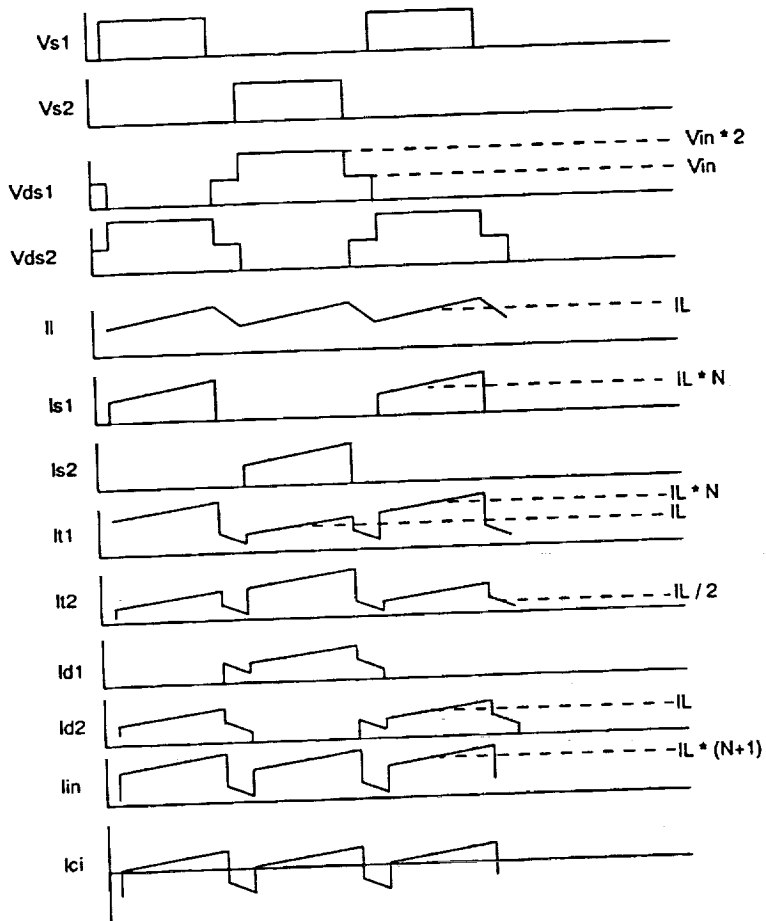
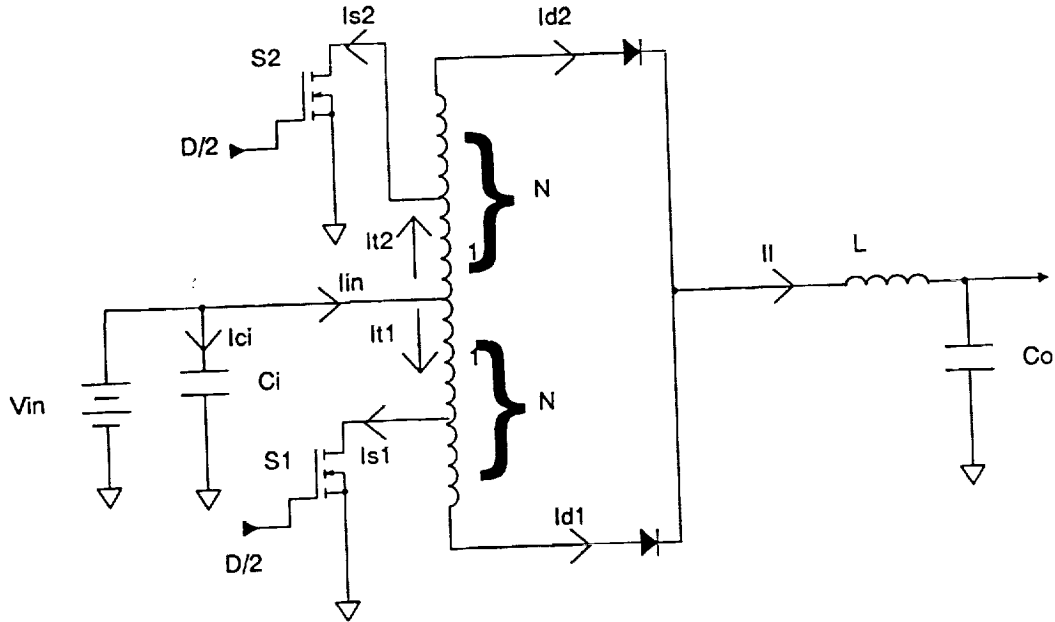

MULTI-MODULE/MULTI-PHASE CONCEPT

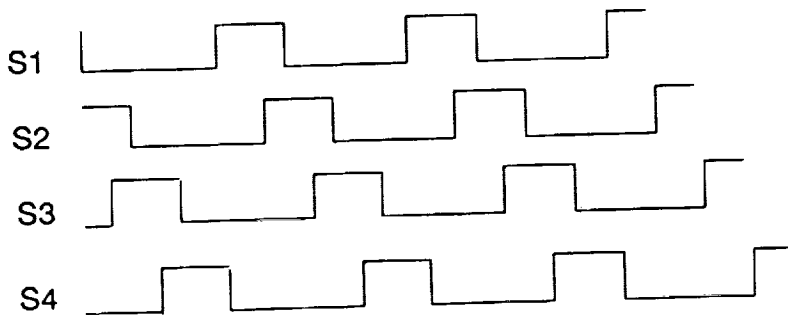
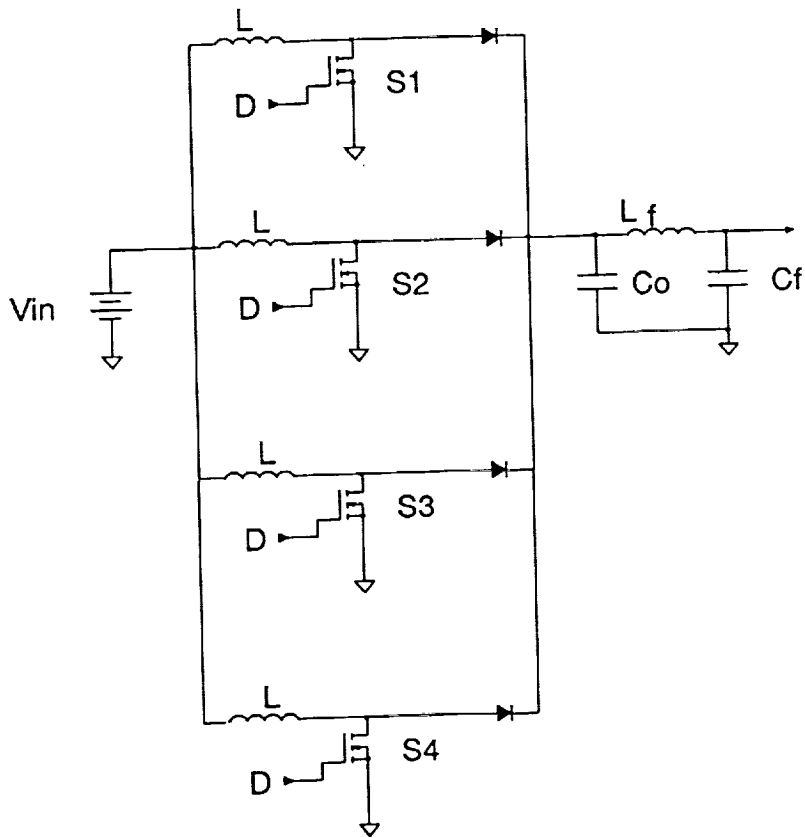

DRAMATIC REDUCTION OF OUTPUT CAP. STRESS
 BENEFICIAL FOR THE BOOST CONVERTER
 MUCH FASTER TRANSIENT RESPONSE POSSIBLE
 CAN BE MORE RELIABLE
 CLOSED-LOOP CURRENT SHARING
 N+1 REDUNDENCY

OUTPUT FILTER DESIGN

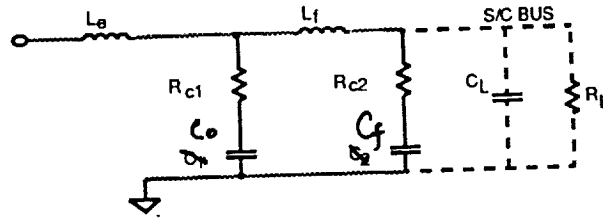

$$C_1 \gg C_2$$

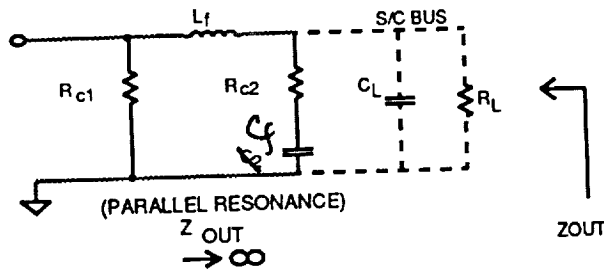

$$C_2 \gg C_1$$

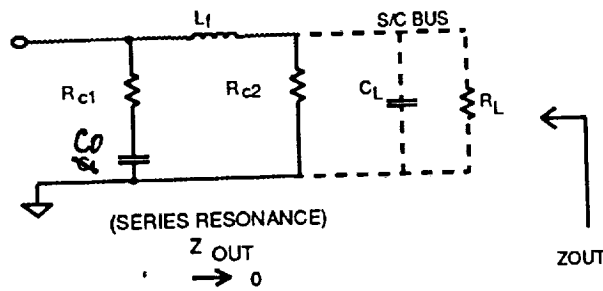

SECOND STAGE CAPACITOR IS BUS CAPACITANCE
 DESIGN FOR 1V P-P RIPPLE ON FIRST STAGE
 SECONDARY RESONANCE DESIGNED FOR $F_s/5$

95% EFFICIENT BOOST DESIGN

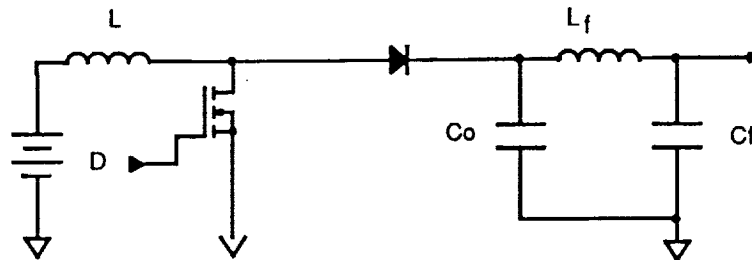

Fs: 110 KHZ

L: 30 μ H

C: 70 μ F

INDUCTOR TURNS: 11

INDUCTOR CORE WIDTH: 9.5E-3 M

INDUCTOR WINDOW WIDTH: 4.3E-3 M

INDUCTOR AIR GAP: 13 MILS

INDUCTOR WIRE SIZE: 1.03E-6 M²

LOSS BREAKDOWN

FET CONDUCTION LOSS: 9.5 W

FET SWITCHING LOSSES: 50.0W

DIODE CONDUCTION LOSS: 13.5 W

DIODE SWITCHING LOSSES: 9.4

INDUCTOR COPPER LOSS: 11.4 W

INDUCTOR CORE LOSS: .9 W

WEIGHT BREAKDOWN

INDUCTOR WEIGHT: .02 KG

CAPACITOR WEIGHT .32 KG

TOTAL: .34 KG

97% EFFICIENT BOOST DESIGN

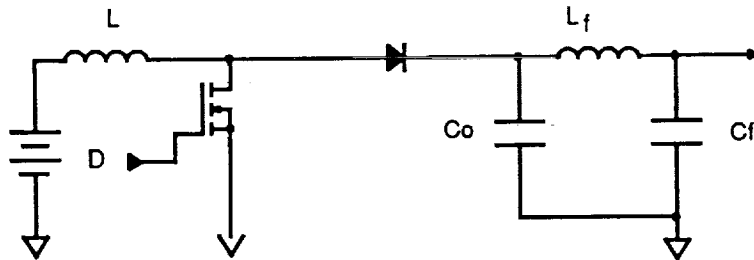

Fs: 45 KHZ

L: 72 μ H

C: 180 μ F

INDUCTOR TURNS: 22

INDUCTOR CORE WIDTH: 1.1E-2 M

INDUCTOR WINDOW WIDTH: 1.1E-2 M

INDUCTOR AIR GAP: 28 MILS

INDUCTOR WIRE SIZE: 3.2E-6 M²

LOSS BREAKDOWN

FET CONDUCTION LOSS: 9.1 W

FET SWITCHING LOSSES: 20.3 W

DIODE CONDUCTION LOSS: 13.5 W

DIODE SWITCHING LOSSES: 3.8 W

INDUCTOR COPPER LOSS: 8.1 W

INDUCTOR CORE LOSS: 0.4 W

WEIGHT BREAKDOWN

INDUCTOR WEIGHT: .08 KG

CAPACITOR WEIGHT .74 KG

TOTAL: .82 KG

95% EFFICIENT VFPPAT DESIGN

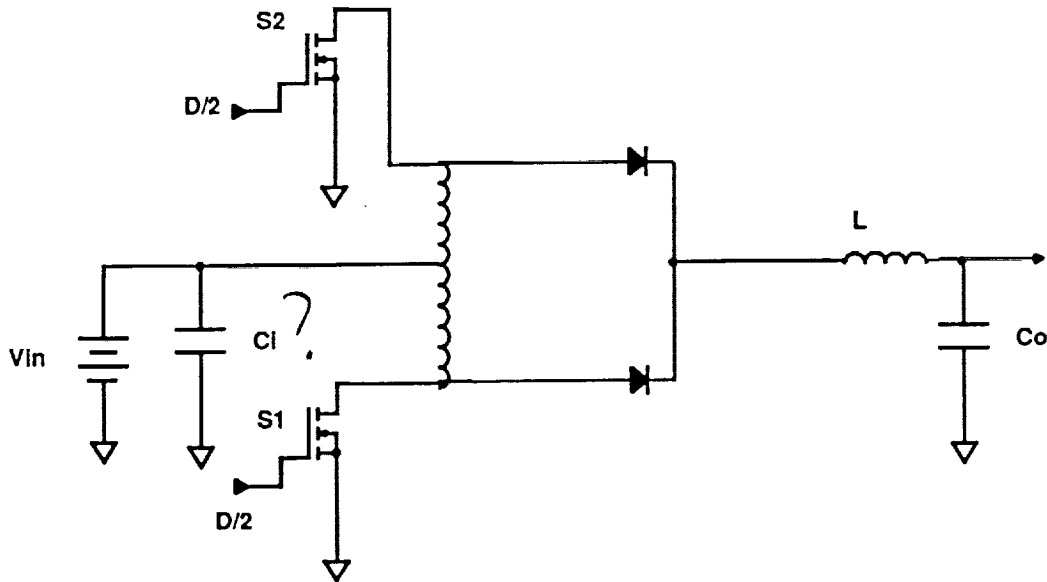

Fs: 75 KHZ
 L: 63 uH
 Co: 3 uF
 Ci: 25 uF

why do we need to filter the input source?
 < EMC concern >

IND. TURNS: 56
 IND. CORE WIDTH: 4.1E-3 M
 IND. WINDOW WIDTH: 9.3E-3 M
 IND. AIR GAP: 32 MILS
 IND. WIRE SIZE: 9.3E-7 M²

XFORMER TURNS: 9
 XFORMER CORE WIDTH: 1.3E-2 M
 XFORMER WINDOW WIDTH 4.0E-3 M
 XFORMER LEAKAGE L: 1.3 uH

LOSS BREAKDOWN

FET CONDUCTION LOSSES: 32.8 W
 FET SWITCHING LOSSES: 17.2 W
 DIODE CONDUCTION LOSS: 13.5 W
 DIODE SWITCHING LOSSES: 7.2
 INDUCTOR COPPER LOSS: 7.4 W
 INDUCTOR CORE LOSS: 0.0 W

XFORMER COPPER LOSS: 11.0 W
 XFORMER CORE LOSS: 1.6 W
 XFORMER LEAKAGE LOSS: 5.9 W

WEIGHT BREAKDOWN

INDUCTOR WEIGHT: .01 KG
 CAPACITOR WEIGHT .13 KG
 XFORMER WEIGHT: .13 KG
 TOTAL: 0.27 KG

95% EFFICIENT FOUR MODULE BOOST DESIGN

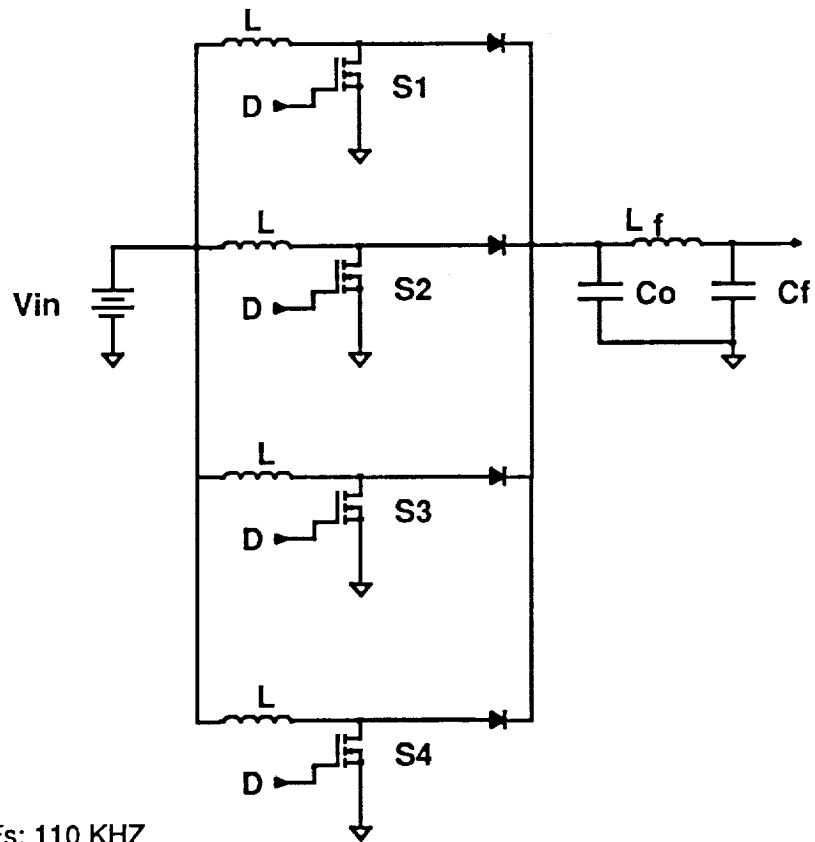

Fs: 110 KHZ

L: 116 μ H

C: 25 μ F

INDUCTOR TURNS: 13

INDUCTOR CORE WIDTH: 8.7E-3 M

INDUCTOR WINDOW WIDTH: 3.2E-3 M

INDUCTOR AIR GAP: 4 MILS

INDUCTOR WIRE SIZE: 3.6E-7 M²

LOSS BREAKDOWN

FET CONDUCTION LOSS: 9.6 W

FET SWITCHING LOSSES: 50.0W

DIODE CONDUCTION LOSS: 13.5 W

DIODE SWITCHING LOSSES: 9.4

INDUCTOR COPPER LOSS: 8.7 W

INDUCTOR CORE LOSS: 2.7 W

WEIGHT BREAKDOWN

INDUCTOR WEIGHT: .04 KG

CAPACITOR WEIGHT .11 KG

TOTAL: .15 KG

97% EFFICIENT FOUR MODULE BOOST DESIGN

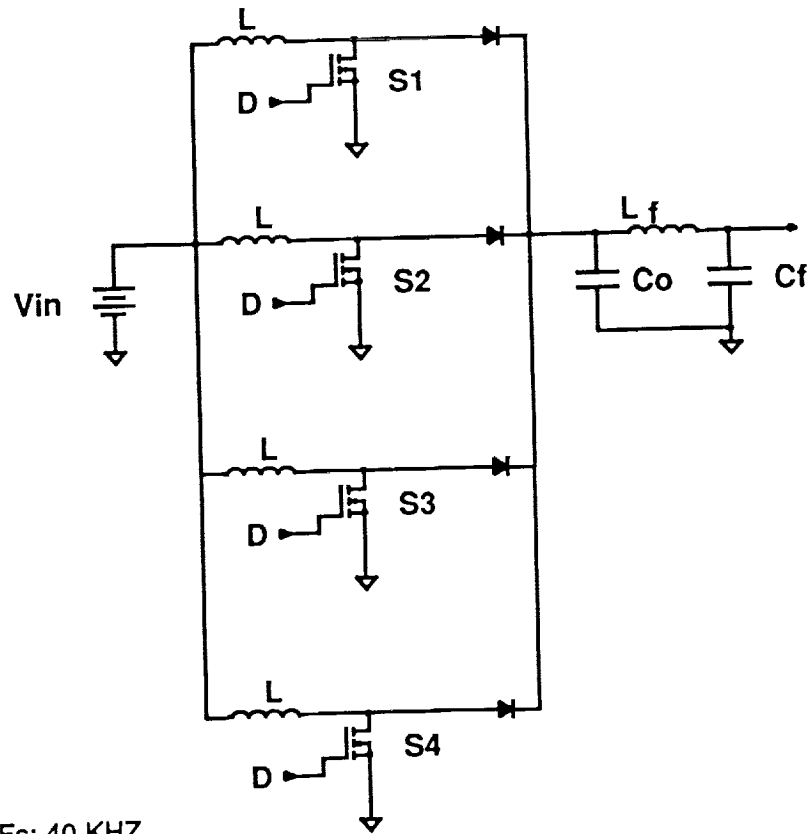

Fs: 40 KHZ

L: 319 uH

C: 50 uF

INDUCTOR TURNS: 5

INDUCTOR CORE WIDTH: 2.2E-2 M

INDUCTOR WINDOW WIDTH: 1.7E-3 M

INDUCTOR AIR GAP: 2 MILS

INDUCTOR WIRE SIZE: 3.3E-7 M²

LOSS BREAKDOWN

FET CONDUCTION LOSS: 9.1 W

FET SWITCHING LOSSES: 17.7 W

DIODE CONDUCTION LOSS: 13.5 W

DIODE SWITCHING LOSSES: 3.3 W

INDUCTOR COPPER LOSS: 9.8 W

INDUCTOR CORE LOSS: 5.3 W

WEIGHT BREAKDOWN

INDUCTOR WEIGHT: .23 KG

CAPACITOR WEIGHT .23 KG

TOTAL: .46 KG

CONCLUSIONS

A MULTI-MODULE BOOST CONVERTER OFFERS THE
LOWEST WEIGHT BATTERY DISCHARGER

97% EFFICIENCY IS OBTAINABLE AND PRACTICAL

FLIGHT QUALIFIED PARTS CAN BE USED

BOTH THE VFPPAT AND THE BOOST DESIGNS
REQUIRE CIC. VFPPAT FOR FLUX BALANCING,
AND THE BOOST FOR DYNAMIC PERFORMANCE AND
STABILITY

THE STABILITY MARGIN OF THE BOOST DESIGN
CAN BE MADE EQUAL TO THE VFPPAT DESIGN

OUTPUT IMPEDANCE AND LOAD TRANSIENT RESPONSE
OF THE BOOST DESIGN CAN BE MADE EQUAL TO
OR BETTER THAN THE VFPPAT DESIGN

**SPACE PLATFORM ORU-LEVEL MODELING AND
CONTROL**

SPACE PLATFORM
ORU LEVEL MODELLING AND CONTROL

PHASE II, TASK 1

- * **BATTERY ORU = BATTERY, CHARGER, & DISCHARGER**
 - **MODULARITY AND REPLACEMENT**
 - **REDUNDANCY**

- * **EASY5 MODEL GENERATION FOR BATTERY ORU**
 - **USE OF EXISTING COMPONENT MODELS**
 - **EASE OF PARALLELING**

- * **PARALLELING OF BATTERY ORUs**
 - **EASY5 SIMULATION**
 - **ANALYSIS**

- * **BATTERY DISCHARGER PARALLELING**

- * **BATTERY CHARGER PARALLELING**
 - **CHARGE CURRENT REGULATION**
 - **BUS VOLTAGE REGULATION**

PARALLEL BATTERY ORU MODULES

120V BUS
(+/- 4%)

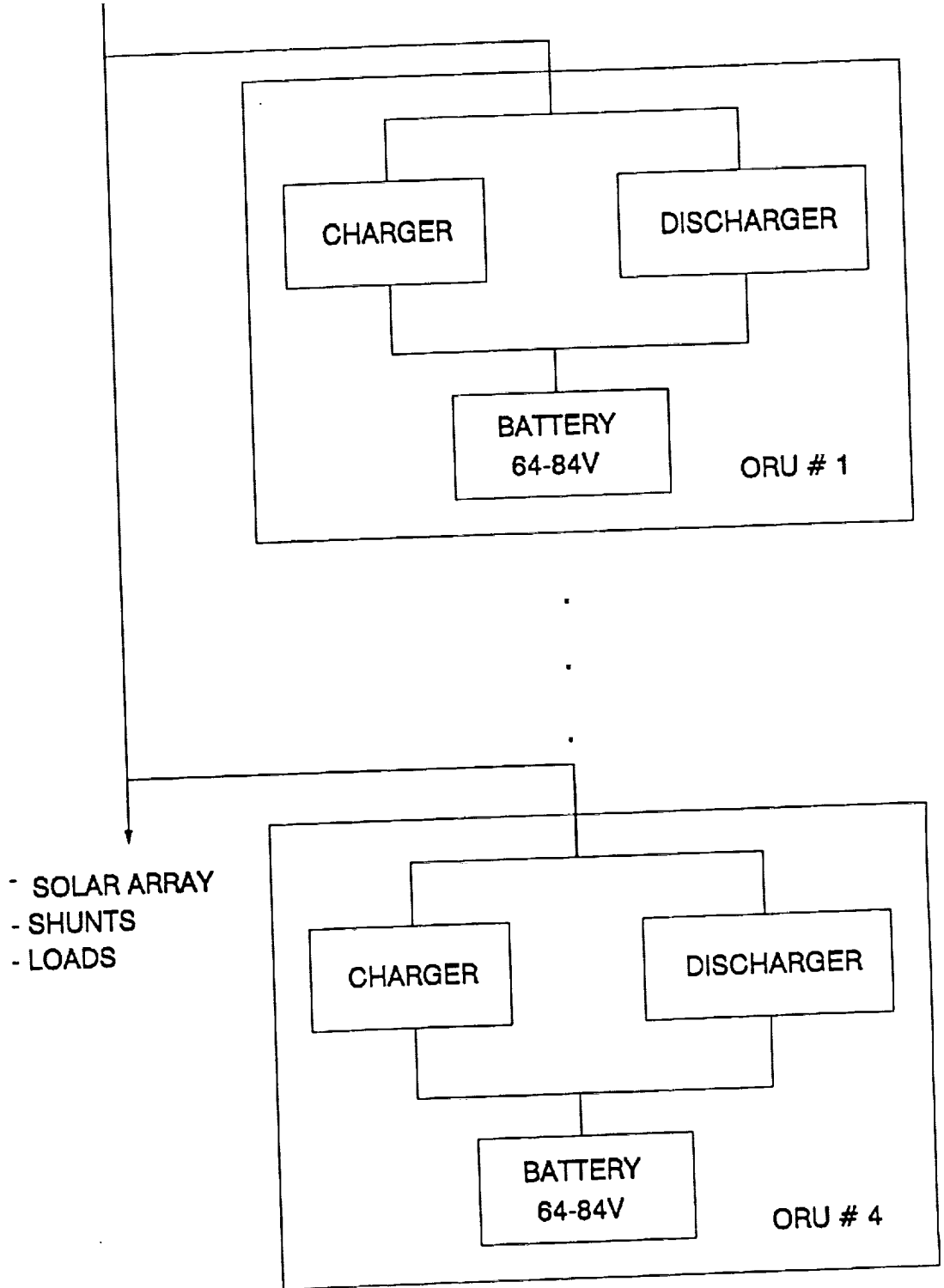

BATTERY DISCHARGE POWER CONVERTER

* BOOST CONVERTER DESIGN FROM SPREADSHEET

* CONVERTER CHARACTERISTICS

- $V_{in} = 64 - 84 \text{ V}$
- $V_{out} = 120 \text{ V}$
- DUTY RATIO = .30 TO .47
- EFFICIENCY = 96 %
- 75 KHz SWITCHING FREQUENCY
- VOLTAGE RIPPLE < 200mV Pk-Pk
- OUTPUT POWER = 1500W CONTINUOUS / 1800W PEAK

* TWO LOOP CONTROL METHOD

- SINGLE COMMON VOLTAGE LOOP
- ONE CURRENT LOOP PER DISCHARGER
- PRELIMINARY LOOP COMPENSATION

* TWO STAGE FILTERING

- LOW OUTPUT VOLTAGE RIPPLE
- LOW OUTPUT IMPEDANCE

EASY5 DISCHARGE CONVERTER MODEL

* LARGE SIGNAL CHARACTERISTICS

* DISCRETE CIRCUIT EQUATIONS

- CONTINUOUS CONDUCTION MODE
- DISCONTINUOUS CONDUCTION MODE

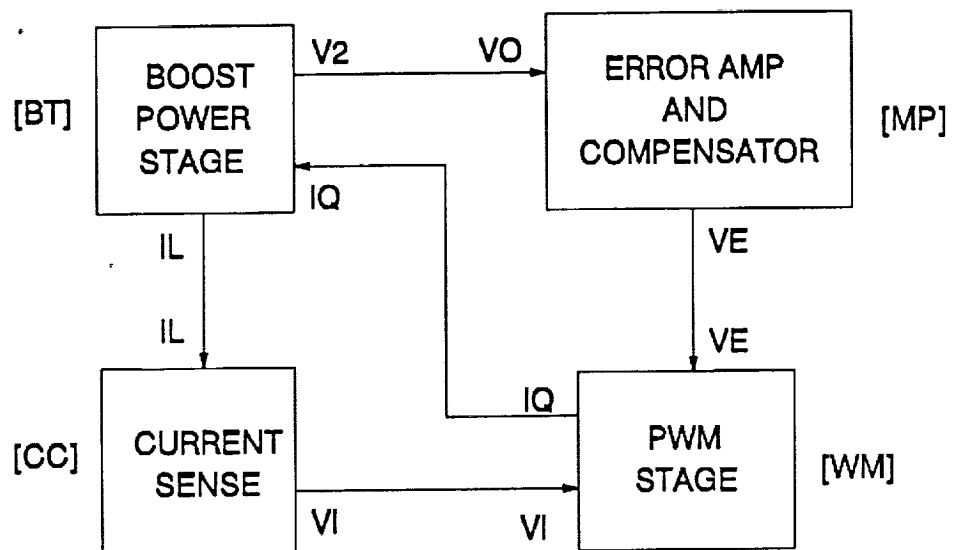

PARALLEL DISCHARGER CONTROL

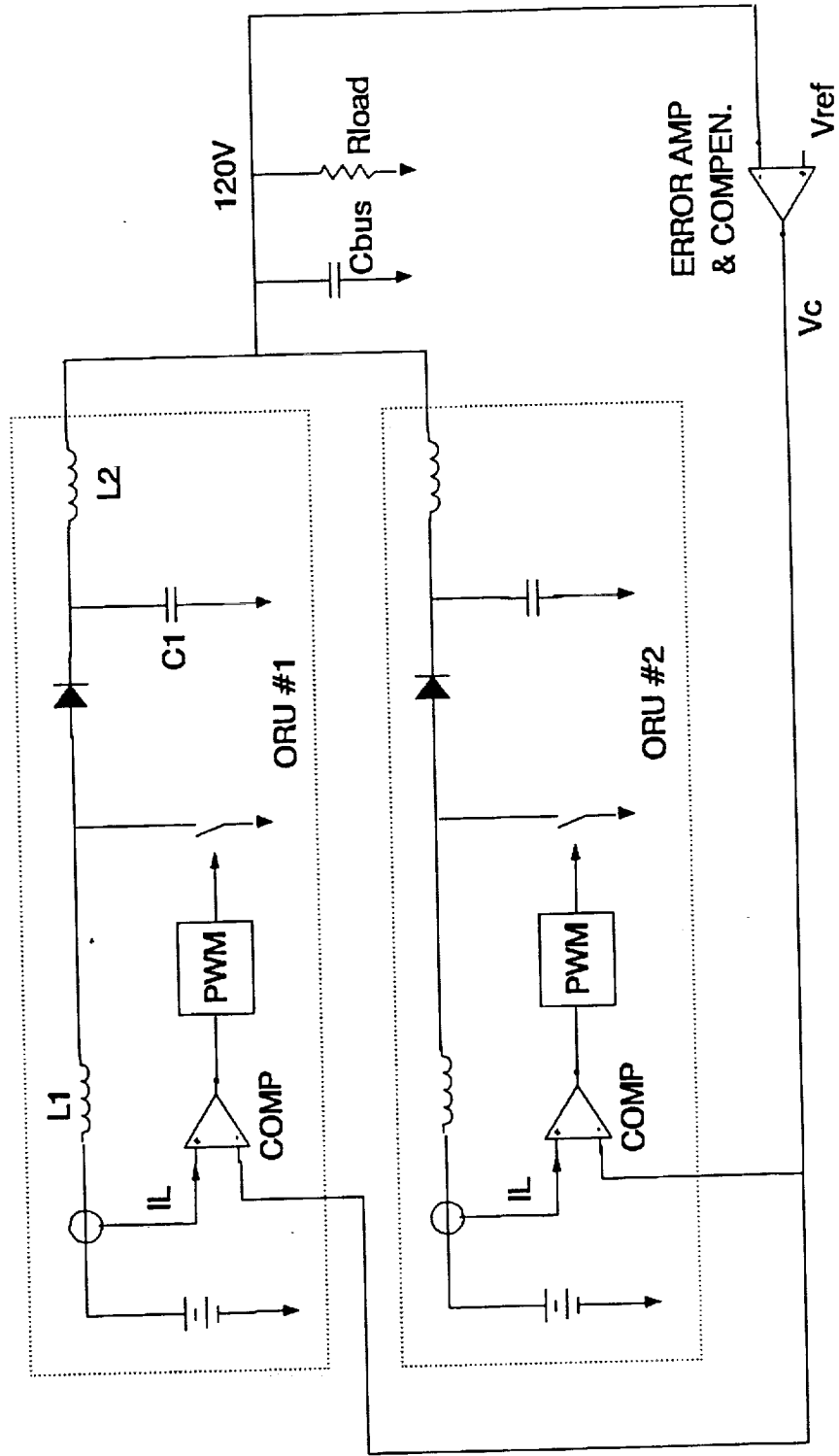

DC ANALYSIS FOR PARALLEL DISCHARGERS

* BATTERY VOLTAGE IMBALANCE

- CHARGE IMBALANCE
- SHORTED CELL

* CURRENT MODE CONTROL : CURRENT SHARING

- BATTERY CURRENT = INDUCTOR CURRENT
- PEAK CURRENT DETECTION

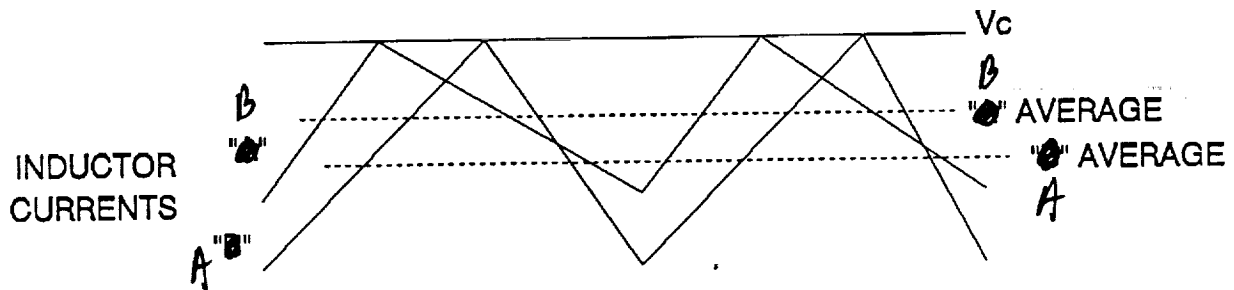

$$\frac{di}{dt} = \frac{dV}{L}$$

BATTERY "A" VOLTAGE > BATTERY "B" VOLTAGE

RESULT : BATTERY "A" AVERAGE CHARGE CURRENT IS HIGHER

* Free Running
* Freq. mismatch.

PARALLEL DISCHARGER CURRENTS
BATTERY "A" = 64V, BATTERY "B" = 84V

check peak value

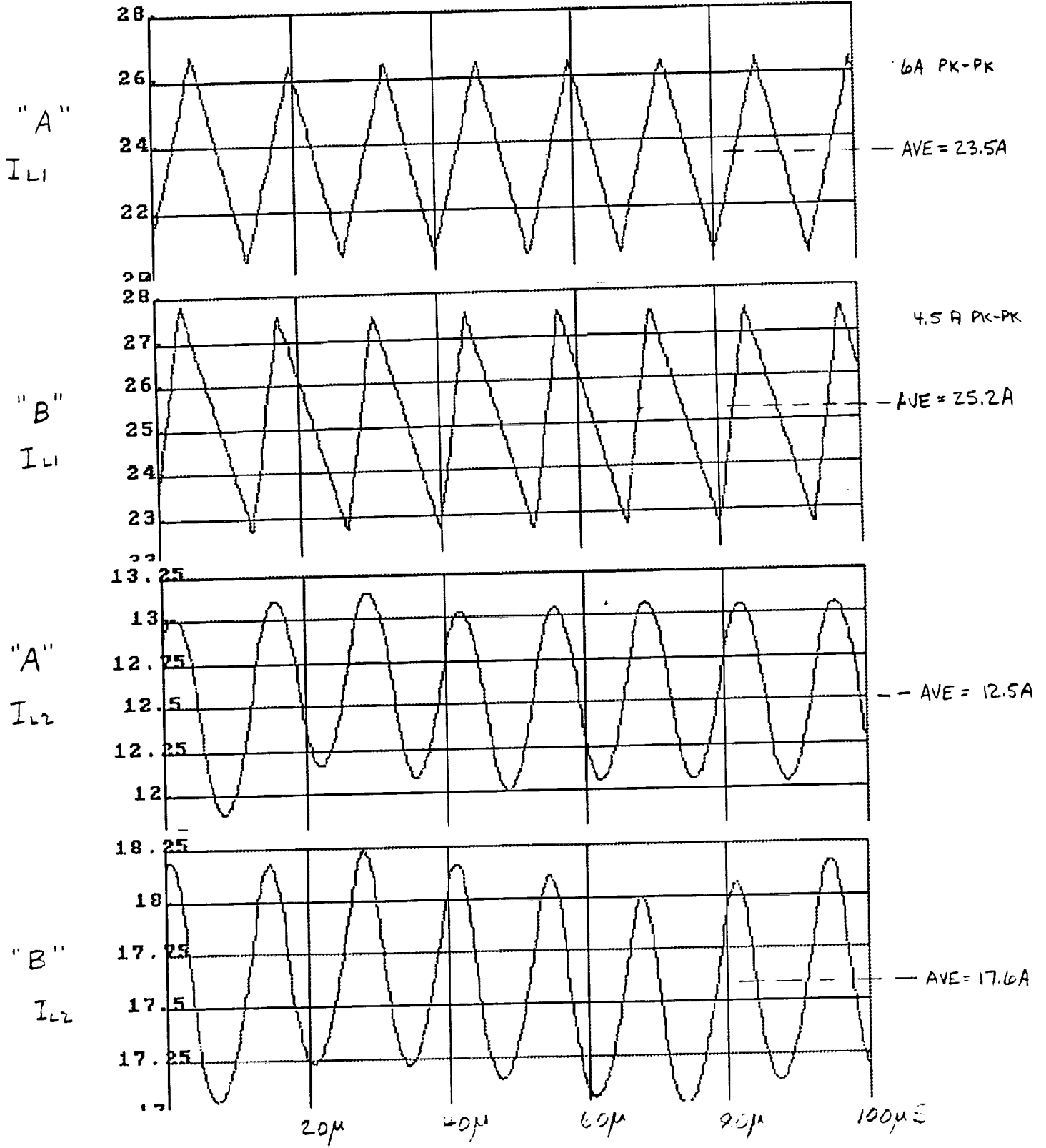

SINGLE DISCHARGER TRANSIENT RESPONSE

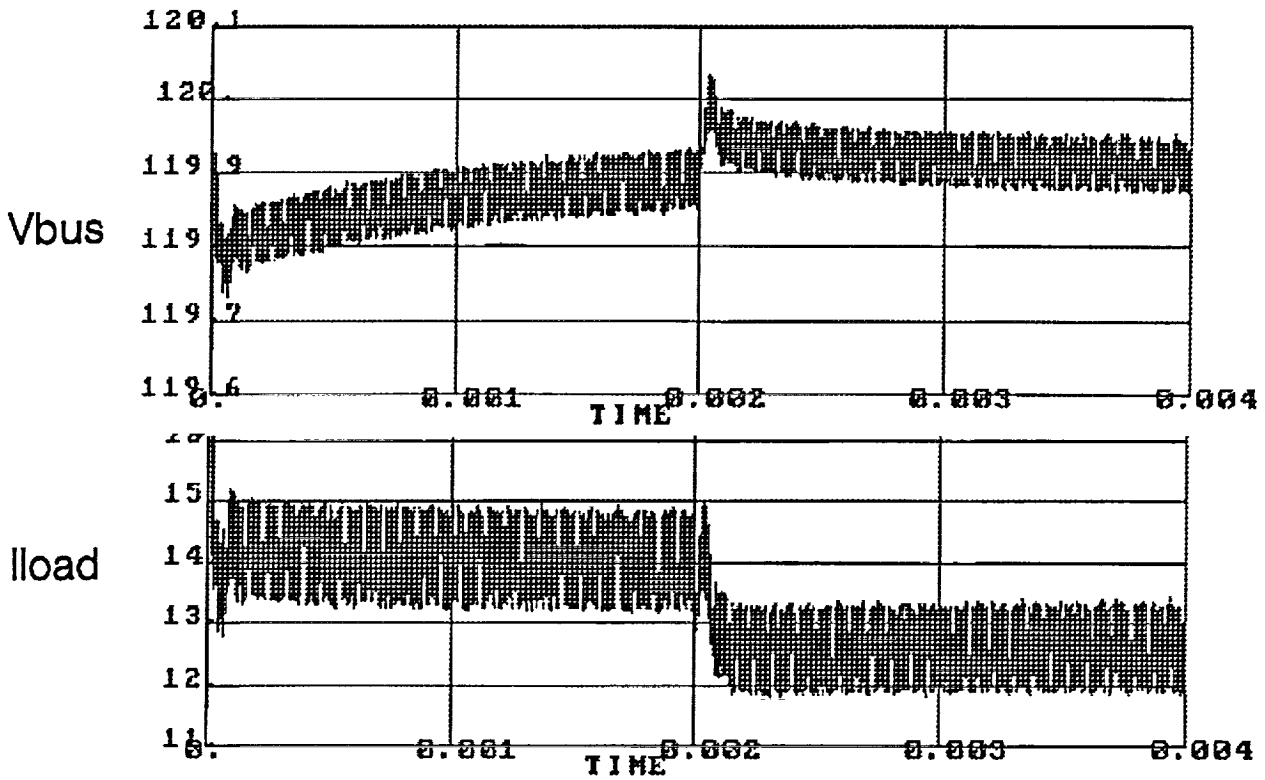

PARALLEL DISCHARGER TRANSIENT RESPONSE

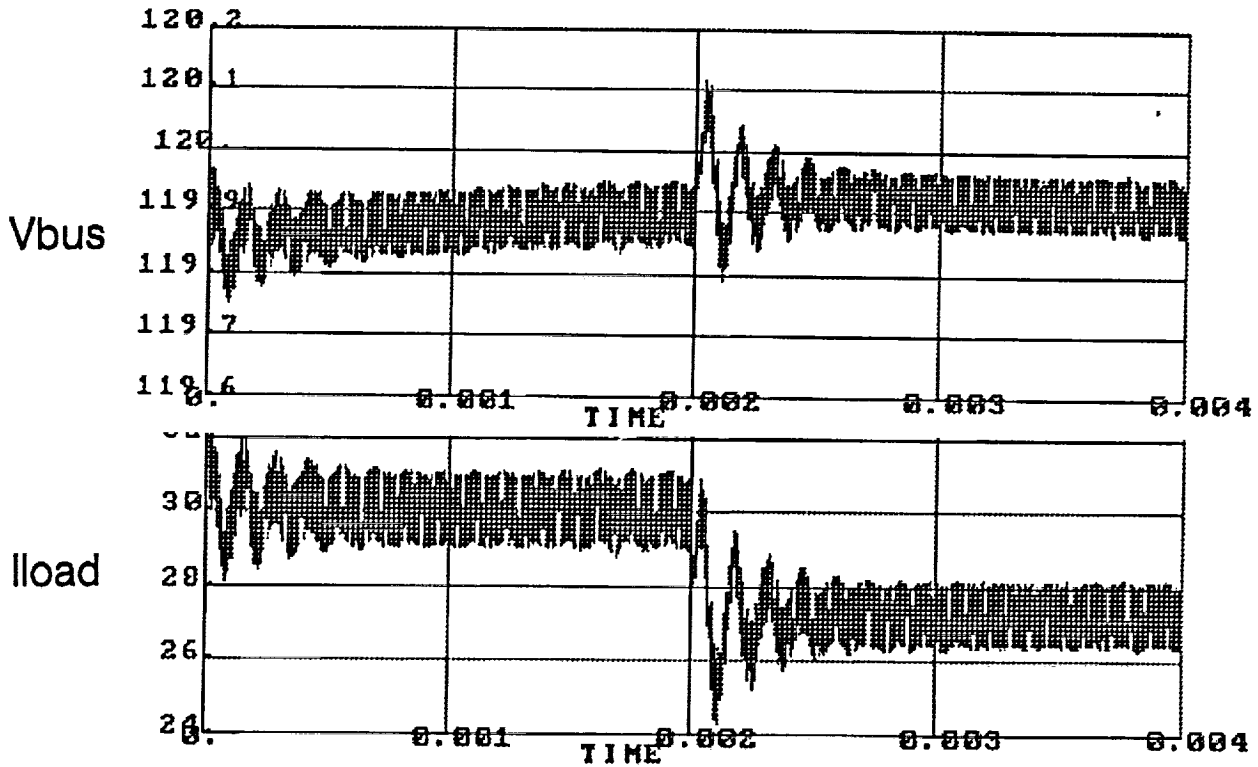

SAME COMPENSATION

SMALL SIGNAL ANALYSIS OF PARALLEL DISCHARGERS

- * STABILITY MODIFIED BY ADDING PARALLEL MODULES
- * MODIFICATION OF FILTER CORNER FREQUENCIES
 - FIRST CORNER FREQUENCY = VARIABLE
 - SECOND CORNER FREQUENCY = FIXED
- * WORST CASE IS FOUR PARALLEL DISCHARGERS
- * LOOP RECOMPENSATION NECESSARY
- * SPICE MODEL FOR FEEDBACK LOOP ANALYSIS

DUU31 CONVERTER, OUTER LOOP GAIN 10
Temperature: 27.0

Date/Time run: 01/31/90 01:30:24

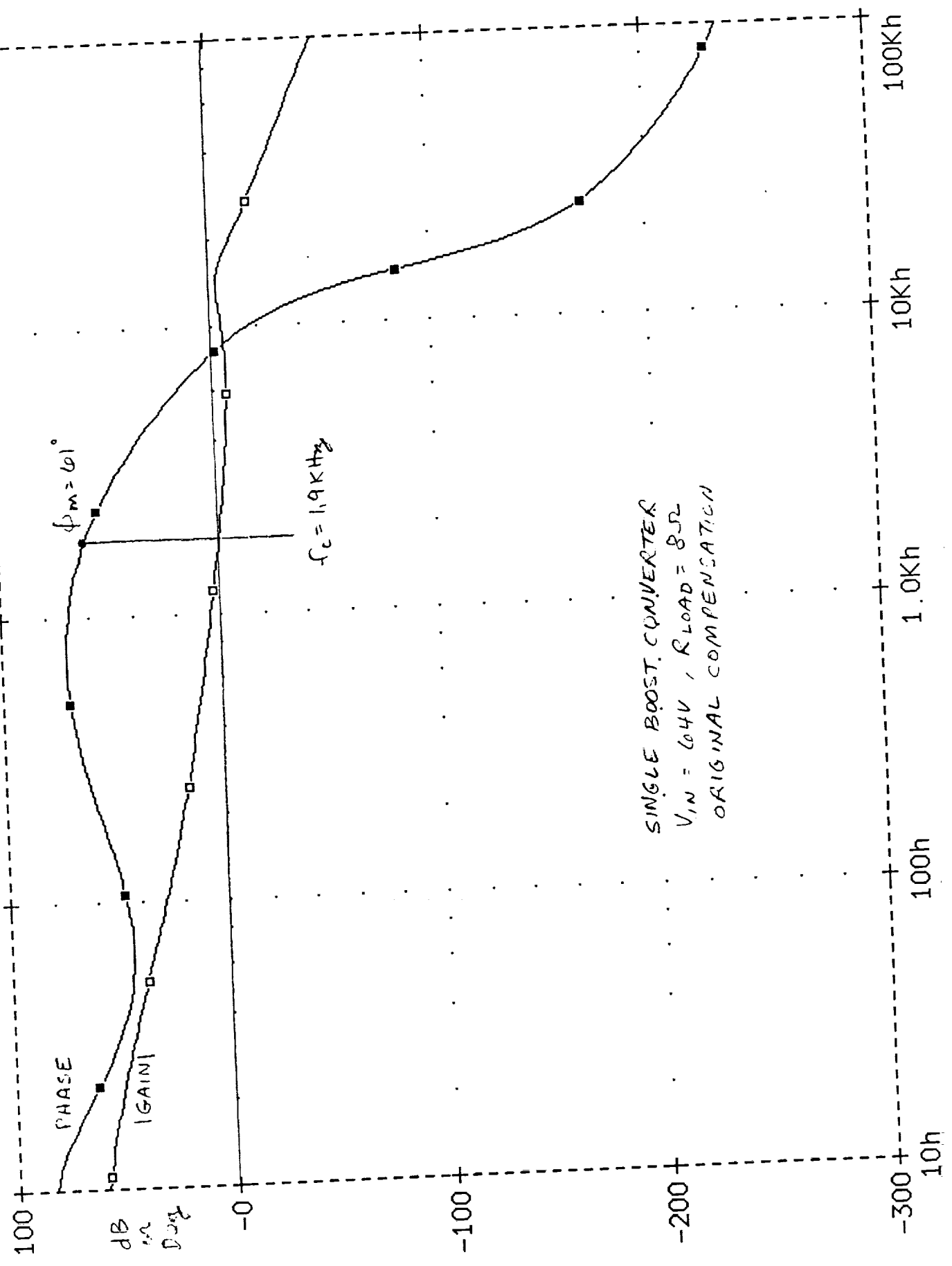

SINGLE BOOST CONVERTER
 $V_{IN} = 64V$, $R_{LOAD} = 8\Omega$
ORIGINAL COMPENSATION

ORIGINAL PAGE IS
OF POOR QUALITY

Temperature: 47.0

Date/Time run: 01/30/90 23:20:18

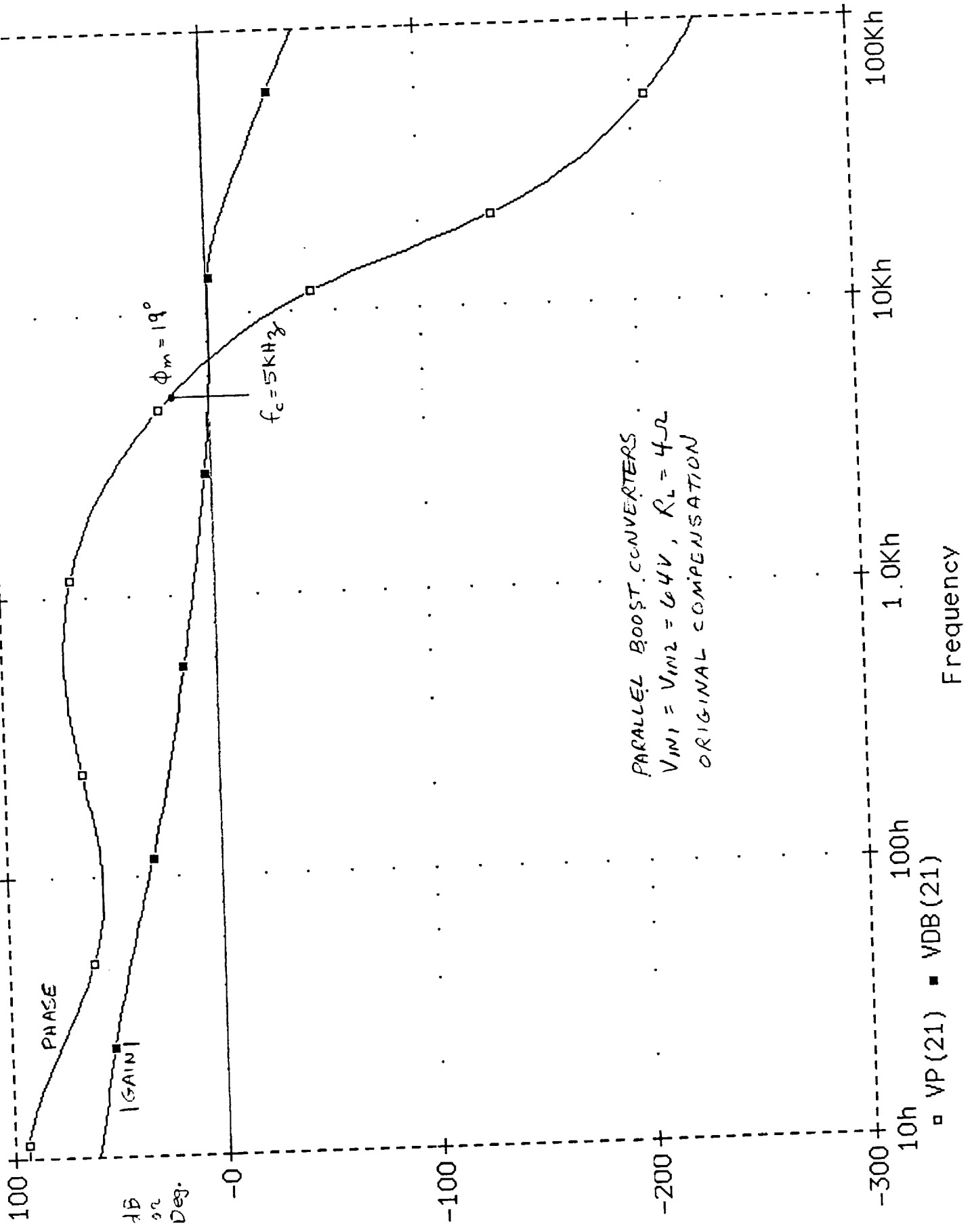

ORIGINAL PAGE IS OF POOR QUALITY

LOOP RECOMPENSATION FOR PARALLEL DISCHARGERS

* TWO POLE & ONE ZERO COMPENSATOR

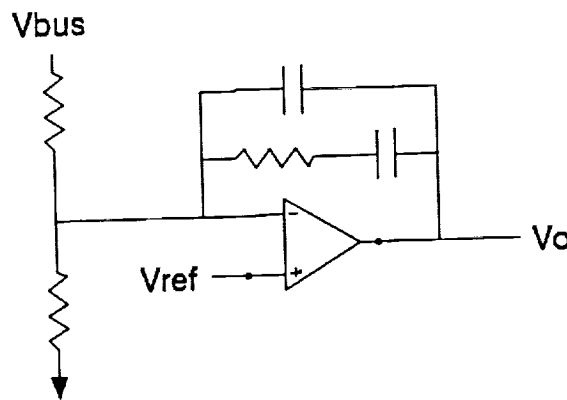

$$\frac{V_o}{V_{bus}} = \frac{W_m(1 + S/W_z)}{S(1 + S/W_p)}$$

* RECOMPENSATION STRATEGY

- SHIFT ZERO TO HIGHER FREQUENCY
- REDUCE DC GAIN

?

* TRADE-OFF MODULARITY FOR LOOP GAIN & BANDWIDTH

- * LOOP GAIN AND PHASE NOT AFFECTED BY BATTERY VOLTAGE IMBALANCE

Date/Time run: 01/30/90 22:27:25

Temperature: 41.0

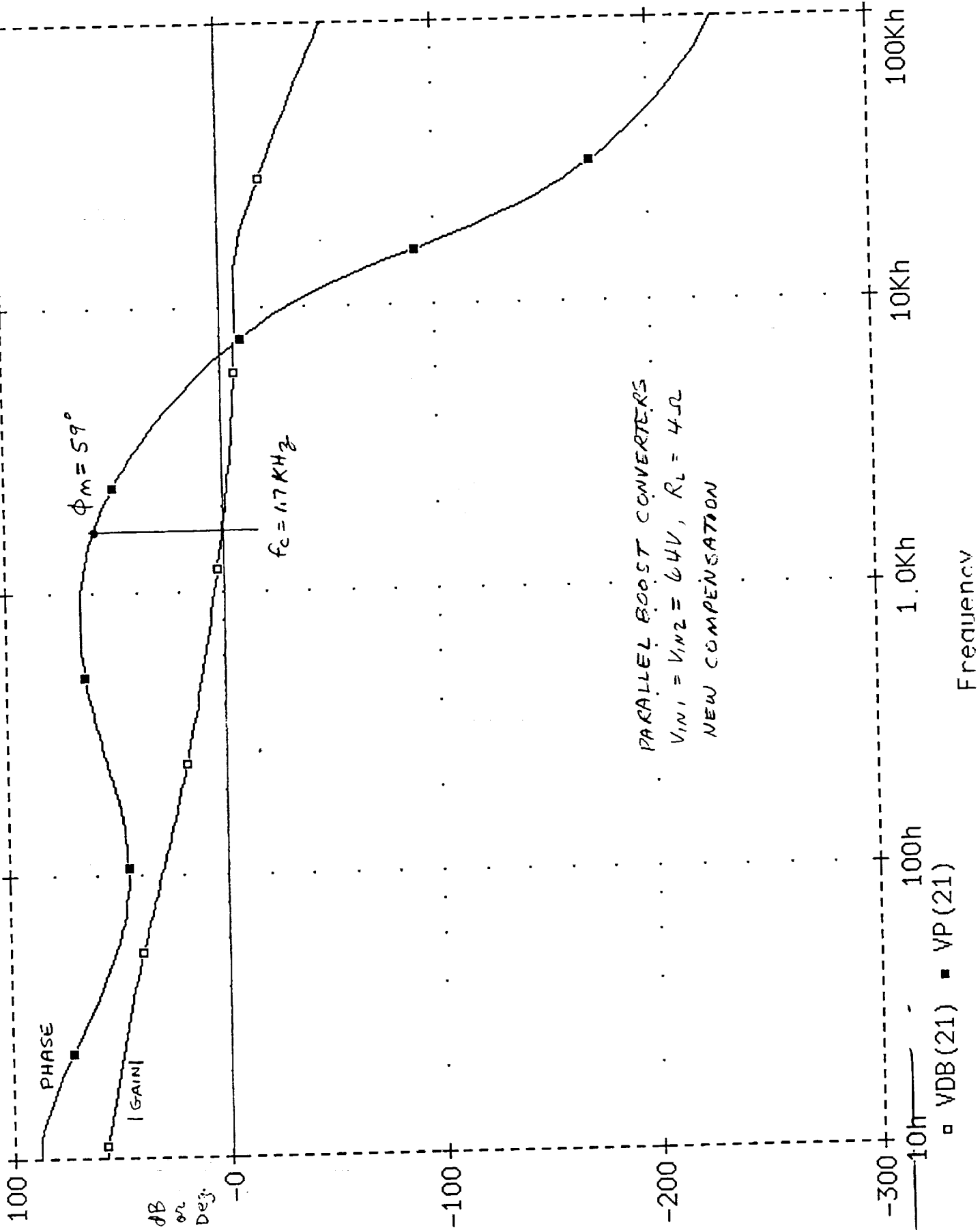

PARALLEL BOOST CONVERTERS
 $V_{IN1} = V_{IN2} = 64V$, $R_L = 4\Omega$
NEW COMPENSATION

ORIGINAL PAGE IS
OF POOR QUALITY

RECOMPENSATED PARALLEL DISCHARGER TRANSIENTS

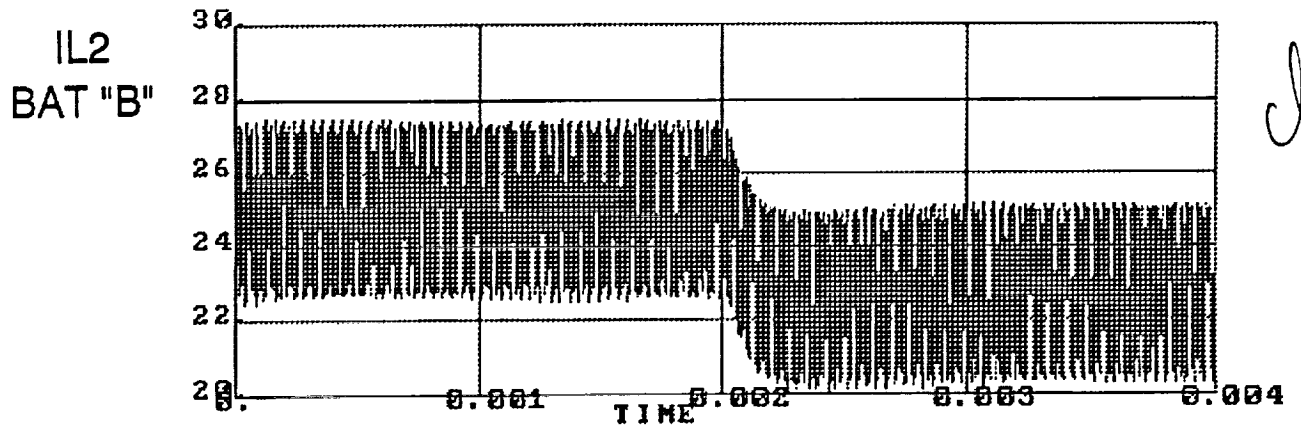
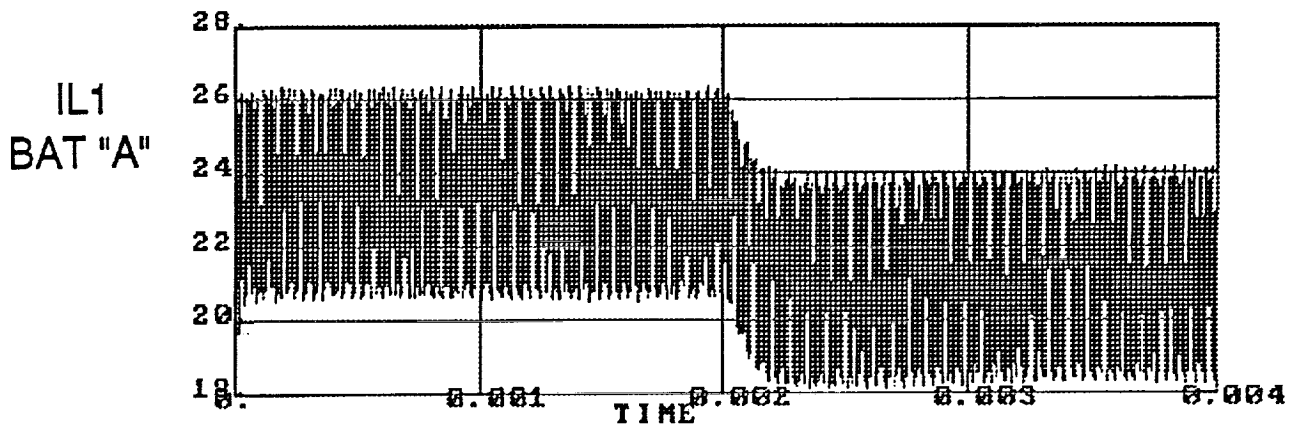
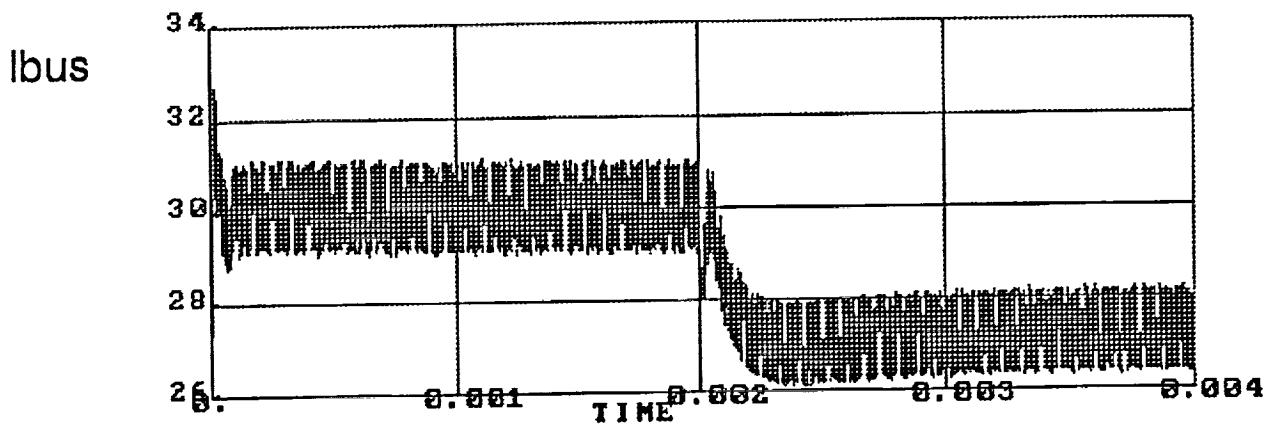
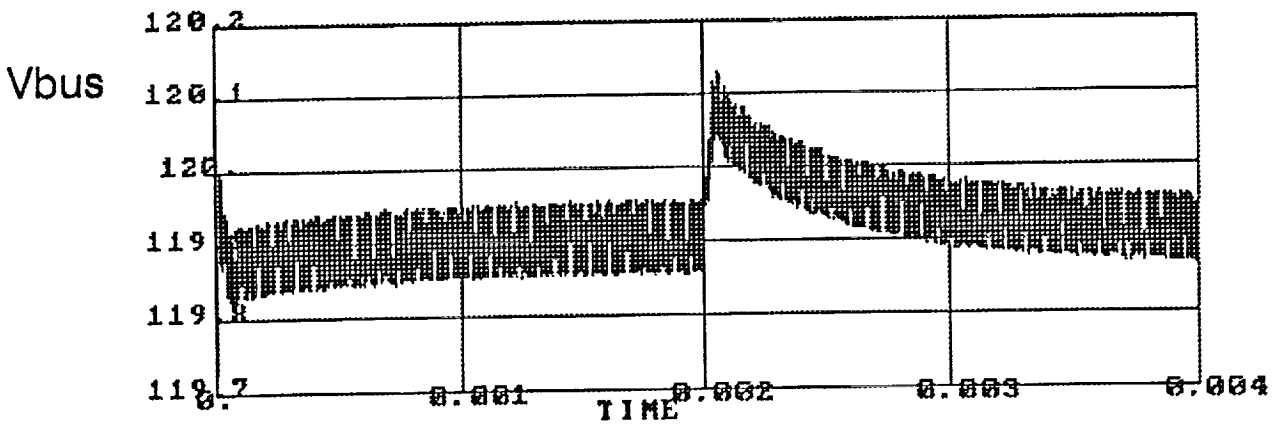

check peak!

Vbat "A" = 64V, Vbat "B" = 84V

EASY5 BATTERY CHARGER MODEL

* BUCK CONVERTER EXAMPLE DESIGN FROM FAIRCHILD REPORT

* CHARGE CURRENT REGULATION

- INDUCTOR CURRENT SENSING & REGULATION
- CHARGE RATE LIMITING

* BUS VOLTAGE REGULATION

- CHARGE CURRENT VARIED TO CONTROL BUS VOLTAGE
- BUCK CONVERTER WITH FEEDFORWARD OF V_{bus}
OR
BOOST CONVERTER WITH FEEDBACK OF V_{bus}

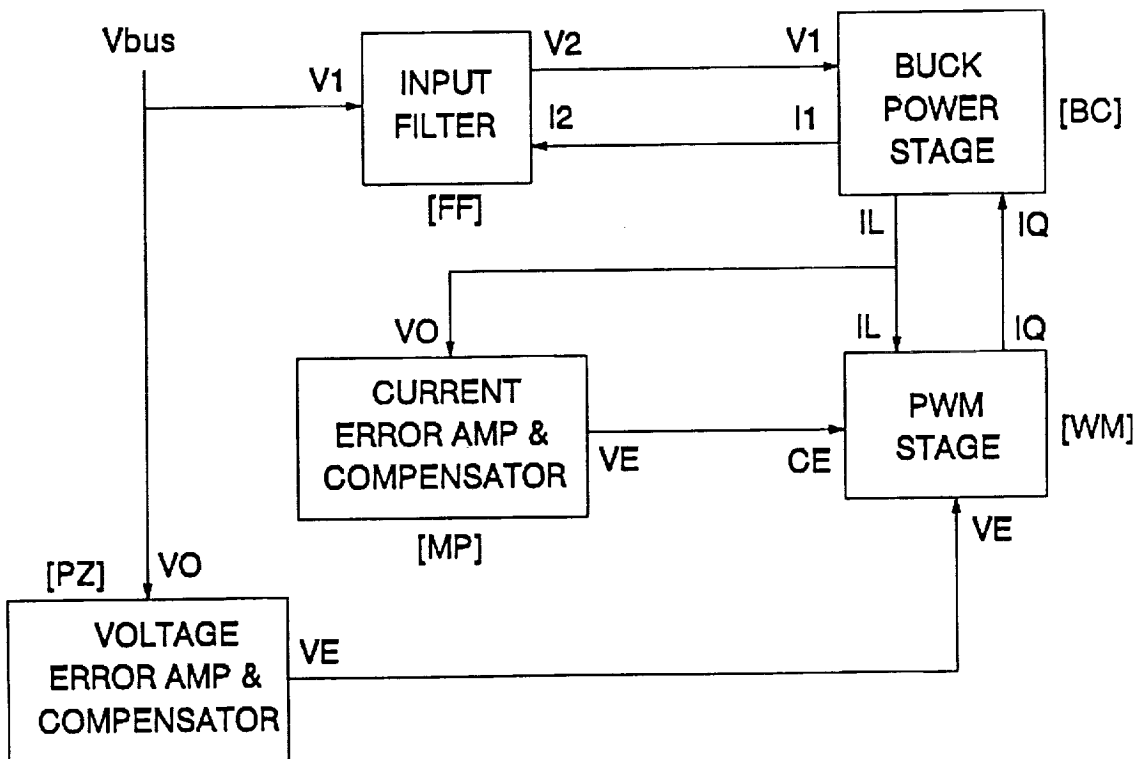

Battery Charger Circuit

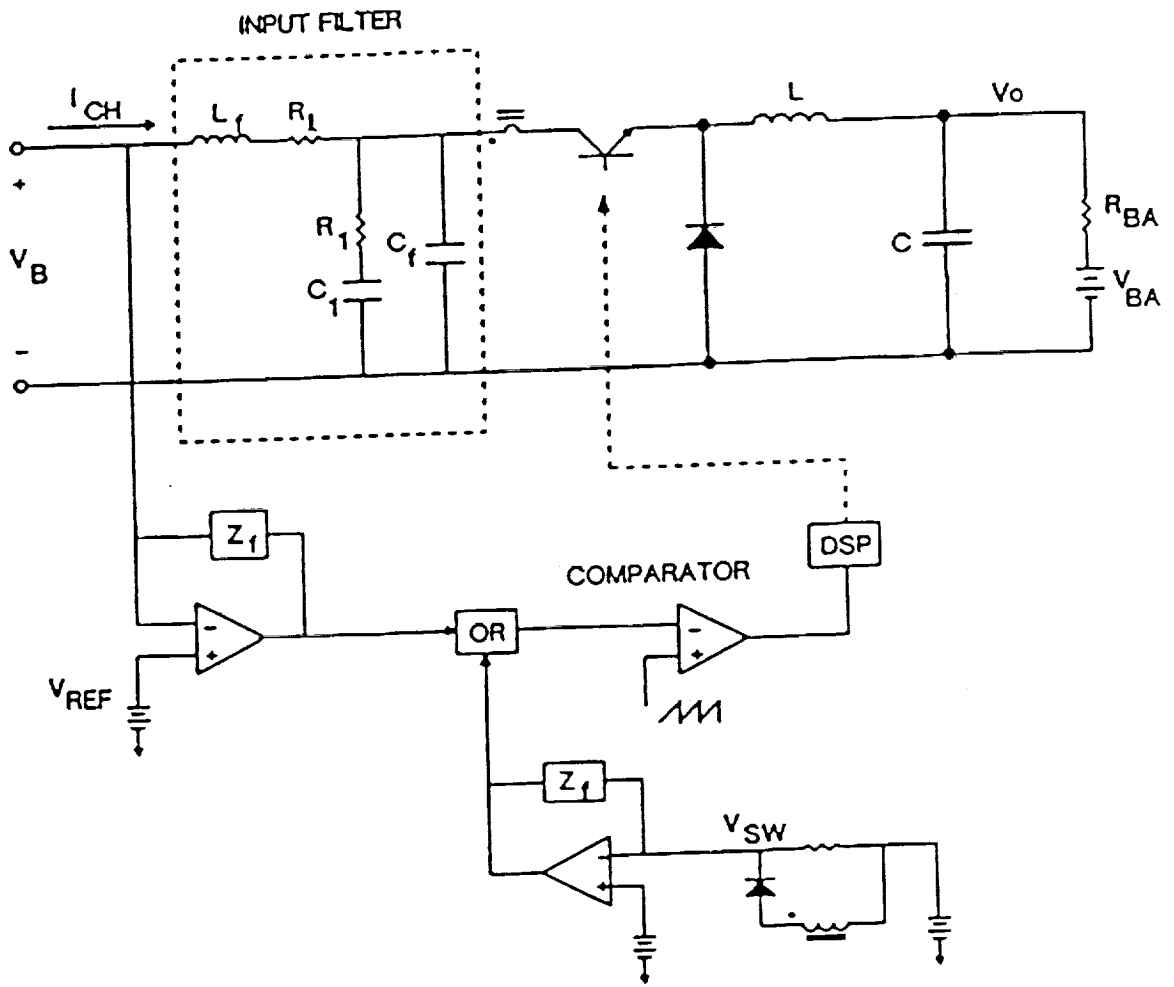

PARALLEL CHARGER MODEL

Redraw the block diagram

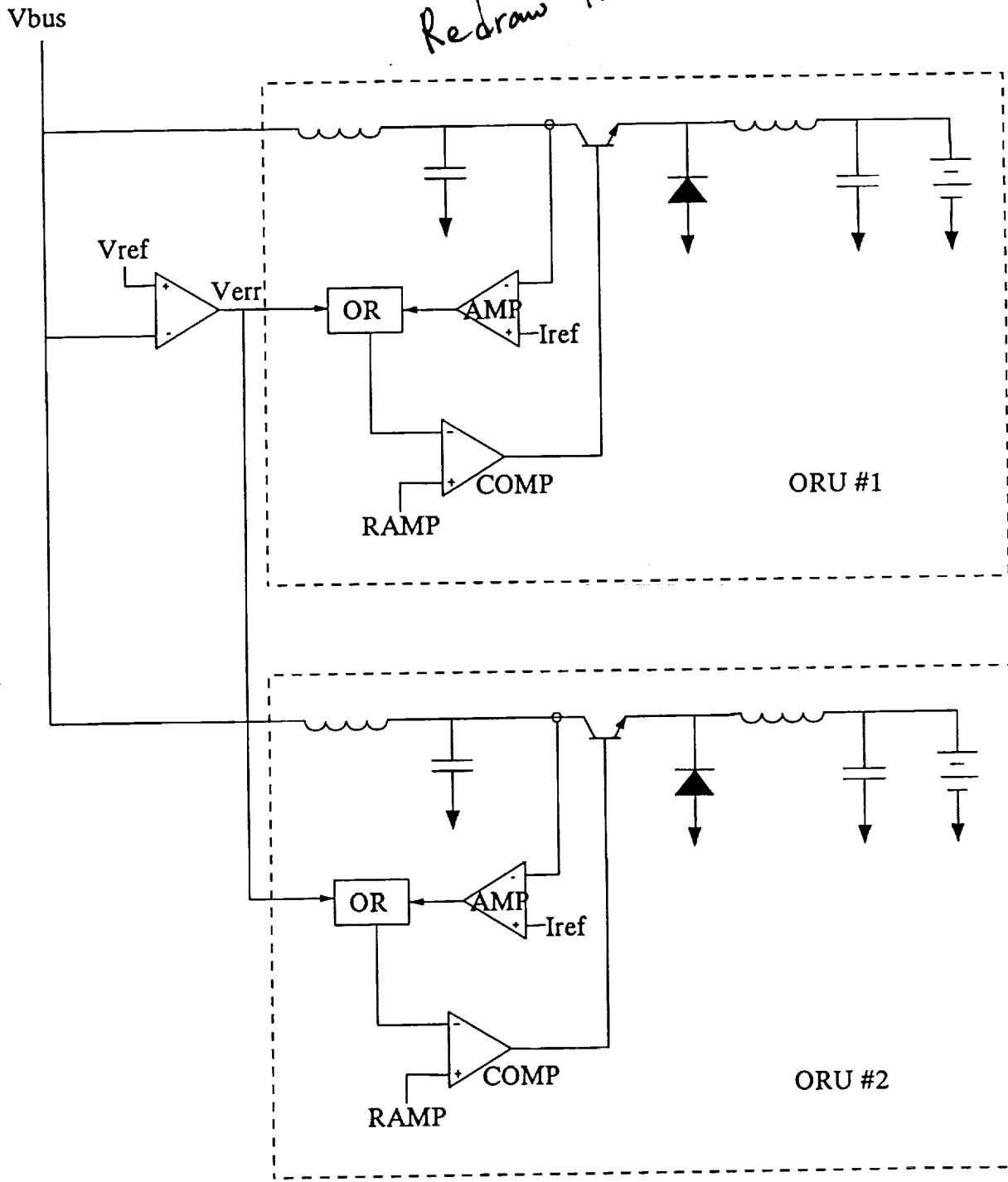

---- CHARGE CURRENT REGULATION MODE ----

SINGLE CHARGER TRANSIENT RESPONSE *

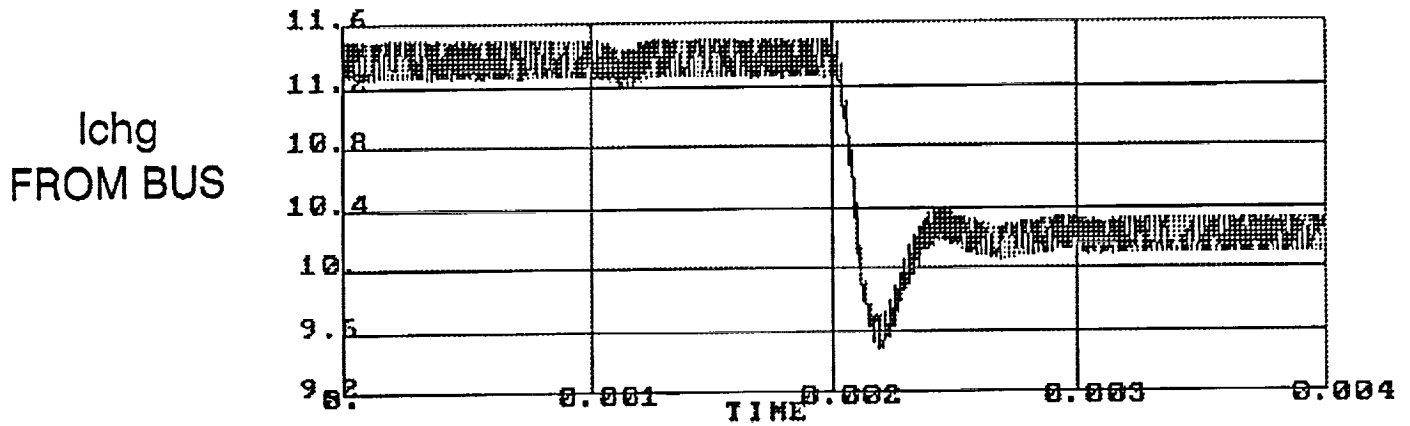
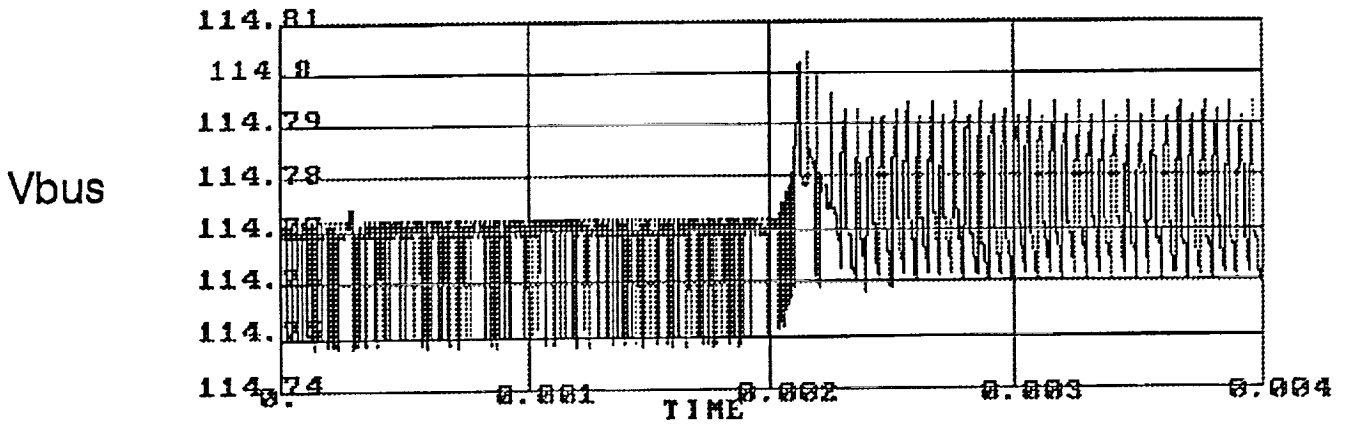

PARALLEL CHARGER TRANSIENT RESPONSE *

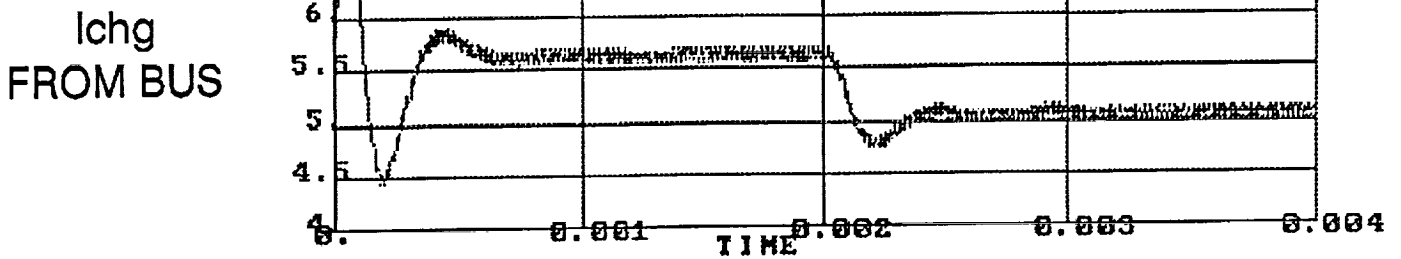
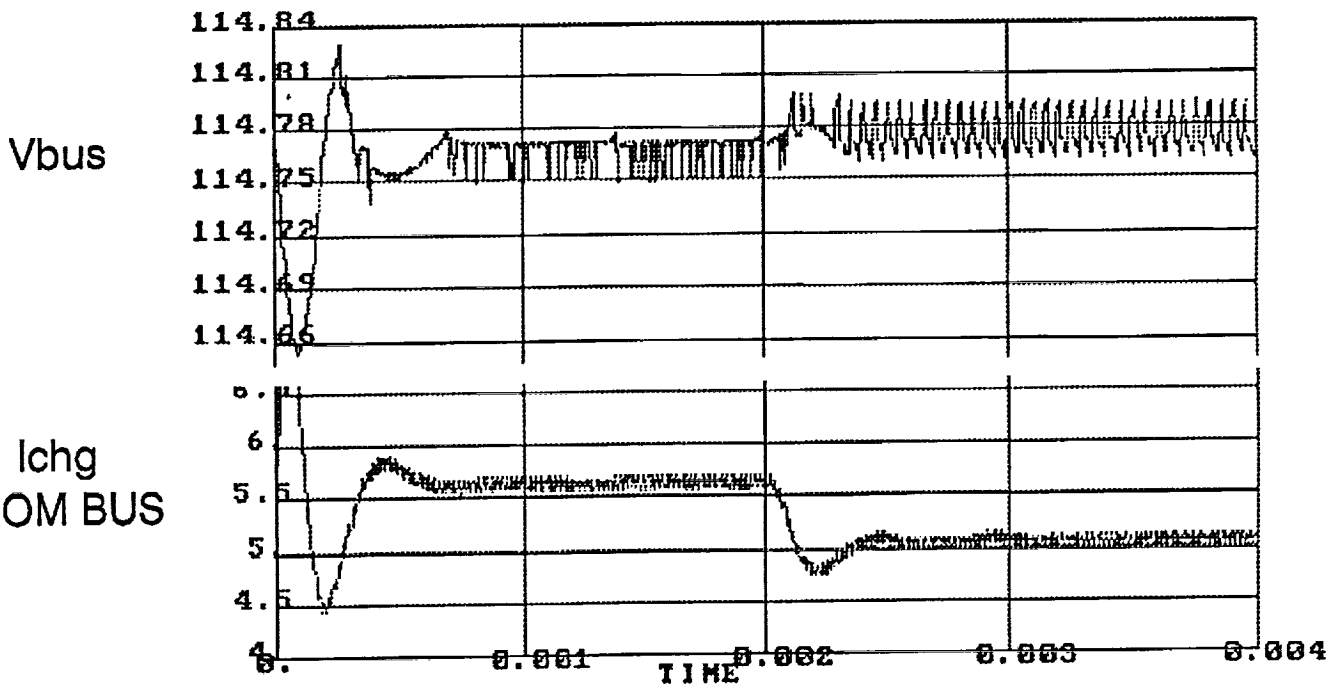

* SAME COMPENSATION FOR EACH CASE

-- BUS VOLTAGE REGULATION MODE --

SINGLE CHARGER TRANSIENT RESPONSE *

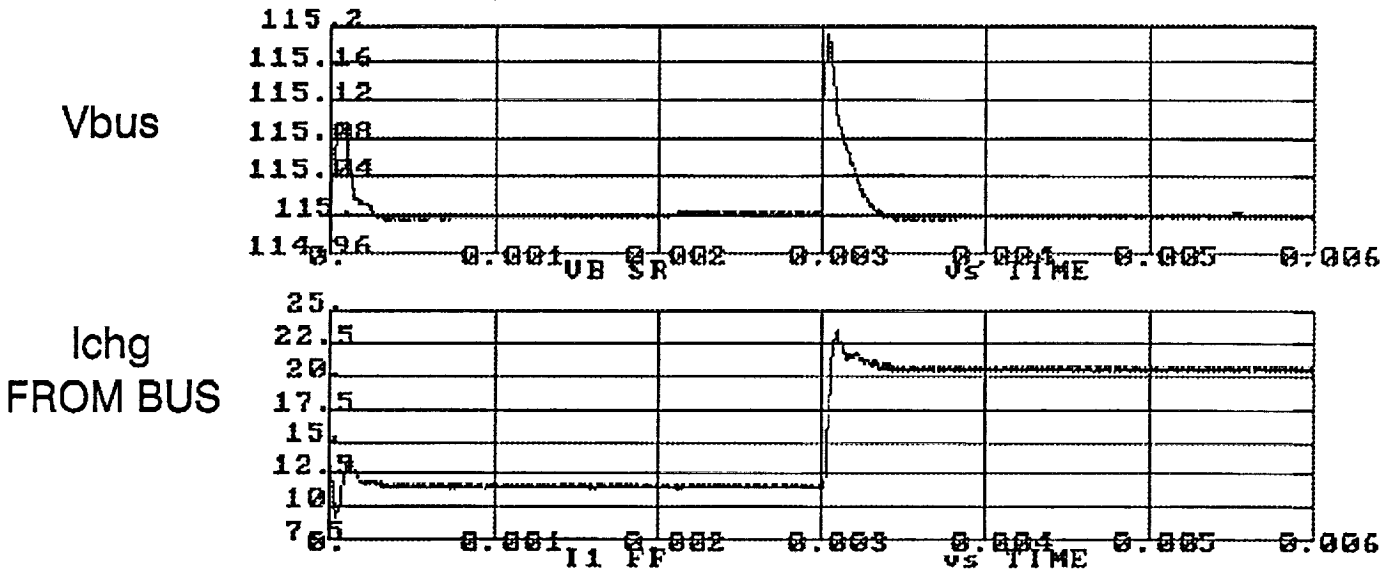

PARALLEL CHARGER TRANSIENT RESPONSE *

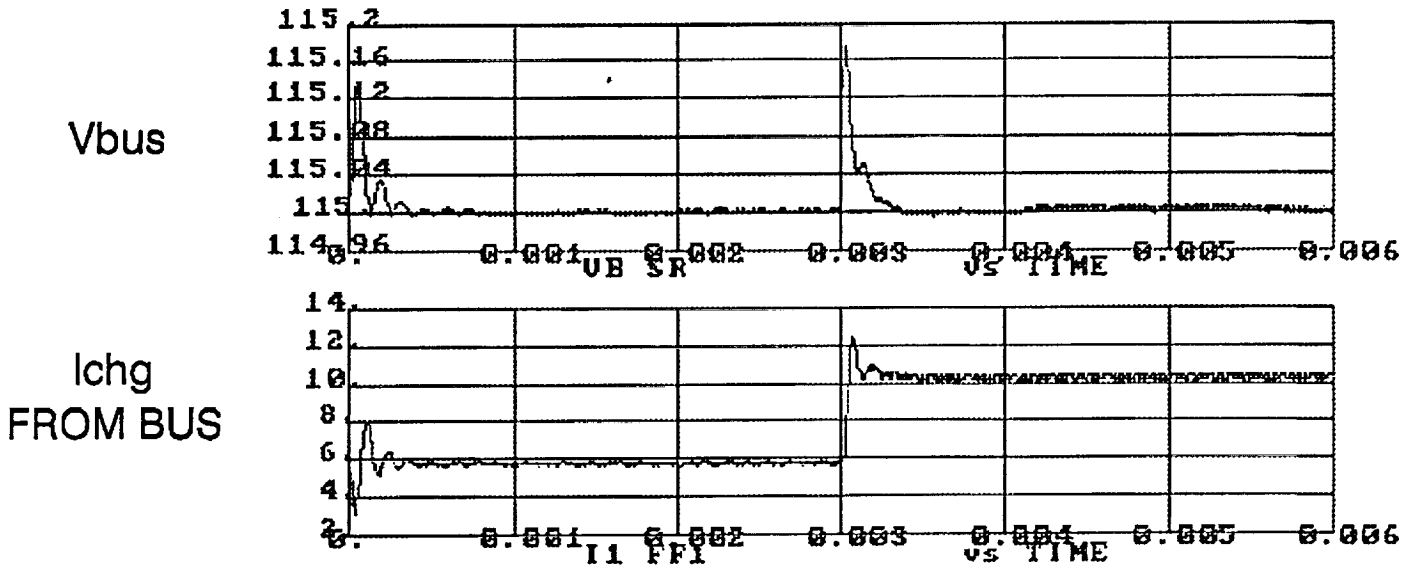

* BOTH BATTERIES = 64V

SUMMARY OF BATTERY ORU MODELLING

*** EASY5 MODELS DEVELOPED FOR BATTERY ORU**

*** PARALLEL DISCHARGER MODELLING**

- DC CURRENT SHARING
- RECOMPENSATION FOR PARALLEL MODULES
- BATTERY VOLTAGE IMBALANCE & LOOP GAIN

*** PARALLEL CHARGER MODELLING**

- CHARGE CURRENT REGULATION MODE
- BUS VOLTAGE REGULATION MODE

**REVIEW OF SPACE PLATFORM POWER SYSTEM
MODELING**

INTRODUCTION

Modeling and simulation :

Large and small signal component models have been developed for the following, using the EASY5 analysis program :

- Solar cells/solar array
- Solar array shunt switching units
- DC-DC converters (buck, boost, flyback, forward)
- Error amplifiers, PWM controllers
- Battery dischargers (boost, tapped-boost) and output filter
- Battery charger (buck) and input filter
- Battery
- Loads
- Mapham inverter
- Spacecraft power system models (for both AC and DC bus)

These models have been used to study

- Transient response to step change of load
- Mode transitions with changes of illumination level
- Paralleling of chargers and dischargers
- Stability study using frequency response plots (small signal models)

Design and analysis :

- Battery charger design
- Battery discharger topology trade-off study
- Battery discharger design
- Analysis of bus impedance, stability and ripple in the shunt regulation mode
- Analysis of bus impedance in charger and discharger regulated modes

Proposed future work :

- Modeling, analysis, design
- Hardware system testbed

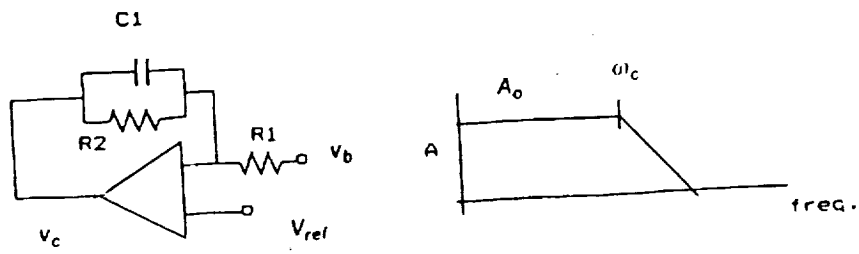

$$A = \frac{v_c}{v_b} = \frac{A_0}{1 + \frac{s}{\omega_c}}$$

$$\omega_c = \frac{1}{C_1 R_2}$$

$$A_0 = \frac{R_2}{R_1}$$

Proportional gain compensator (select PG = 1)

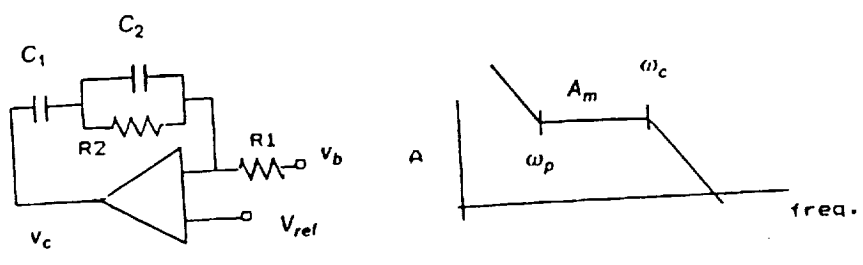

$$A = \frac{v_c}{v_b} = \omega_m \frac{(1 + \frac{s}{\omega_p})}{s(1 + \frac{s}{\omega_c})}$$

$$A_m = \frac{R_2}{R_1} (1 + \frac{C_2}{C_1})$$

$$\omega_p = \frac{1}{R_2(C_2 + C_1)} \quad \omega_c = \frac{1}{C_2 R_2} \quad \omega_m = \frac{1}{C_1 R_1}$$

Integrator type compensator (select PG = 0)

Fig. 2.1-5 Compensators for [SR] model

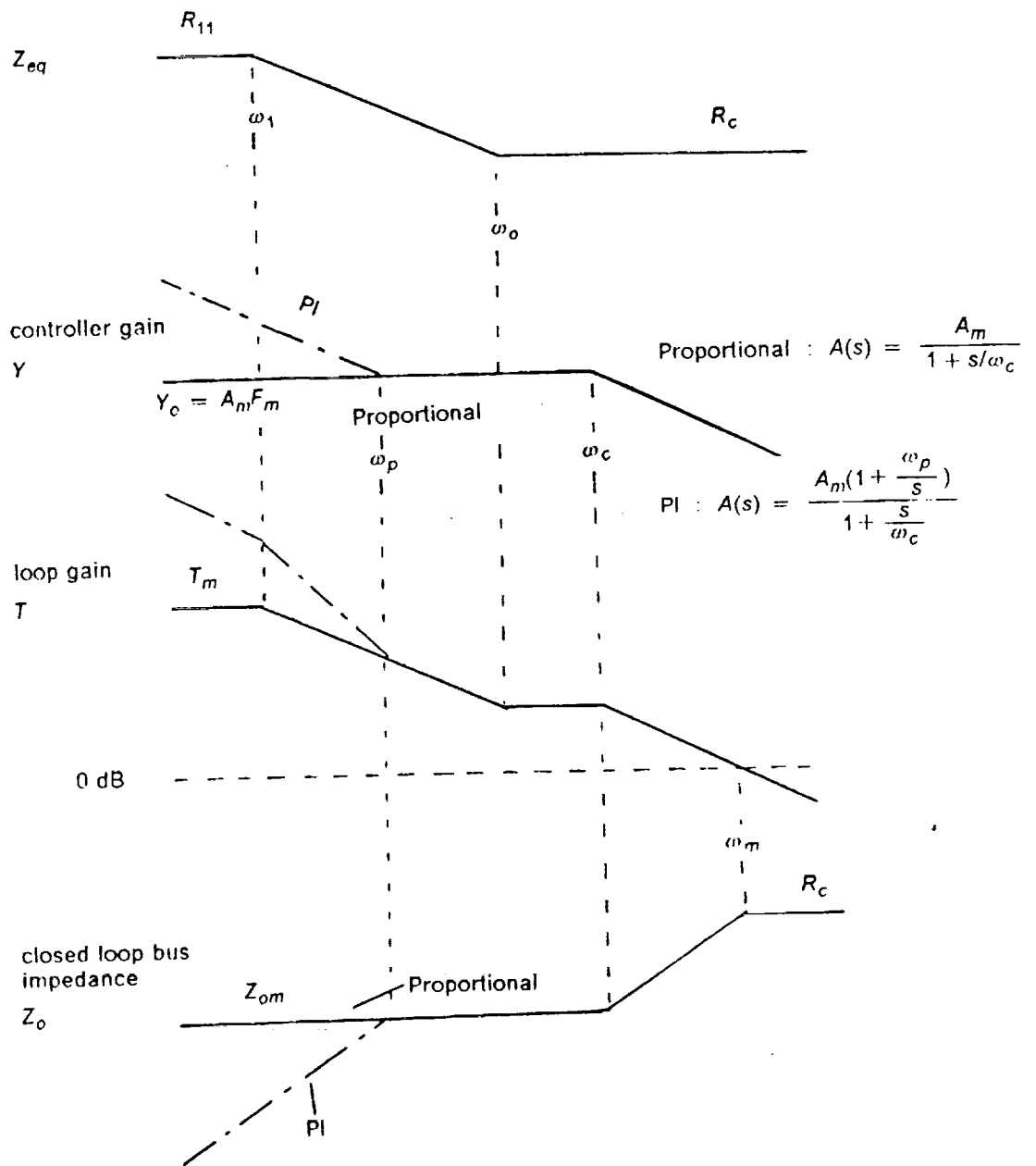

Fig. 4 Loop gain and bus impedance plots

Salient design features for shunt unit and bus capacitor

- For a properly designed system, the peak bus impedance is the ESR of the bus filter capacitor (this determines the overshoot for a step load change)
- A proportional controller has fast transient response but has a load dependant bus voltage error (a voltage "band" requirement)
- An integrator type compensator can decrease the voltage band requirement, but the zero required to reduce phase lag results in a low frequency pole in the bus impedance. This may make the transient response slower.
- The bus ripple depends on the following factors :

Switching frequency
Bus capacitor ESR
Bus capacitance
Current per parallel switch

$$V_{pp} = I_p R_c + D(1 - D) \frac{T_s I_p}{C}$$

where

D = duty ratio modulation
 R_c = bus capacitor ESR
 I_p = current from one set of NPS strings
 T_s = switching period
 C = bus capacitor

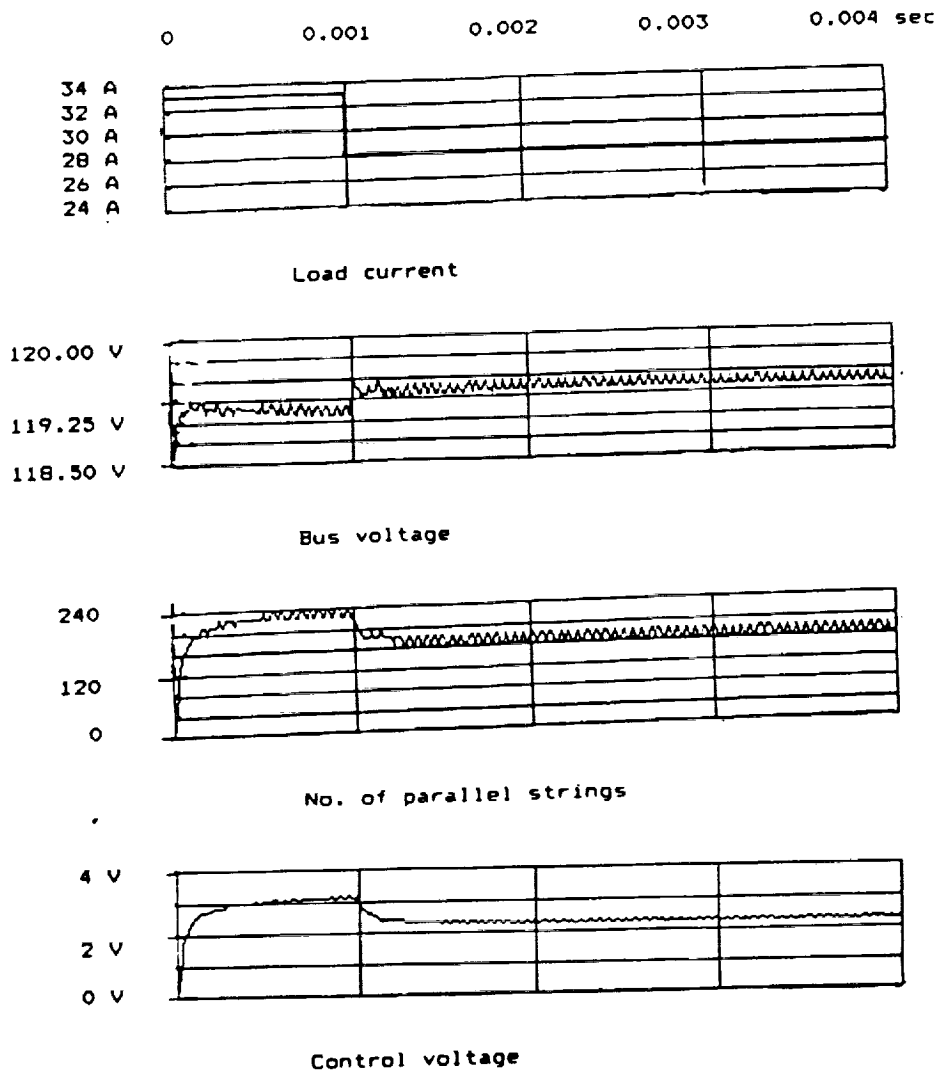

Fig. 5a Simulation for proportional compensator

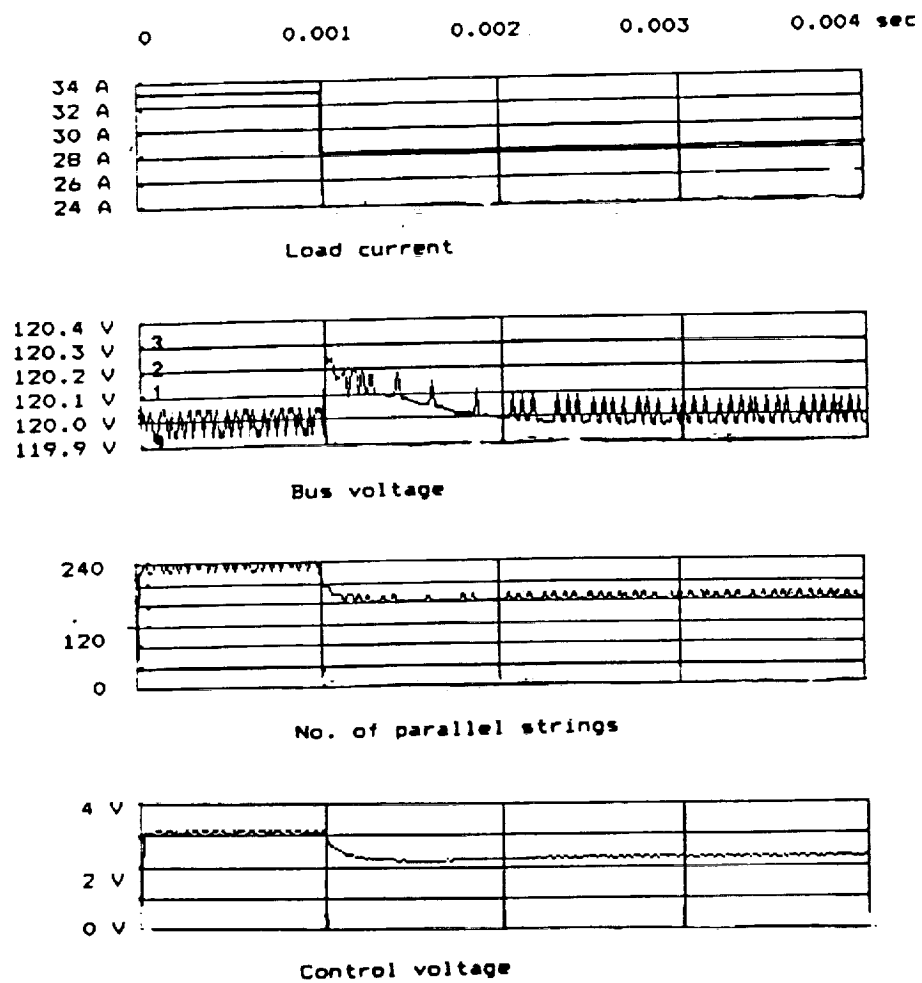
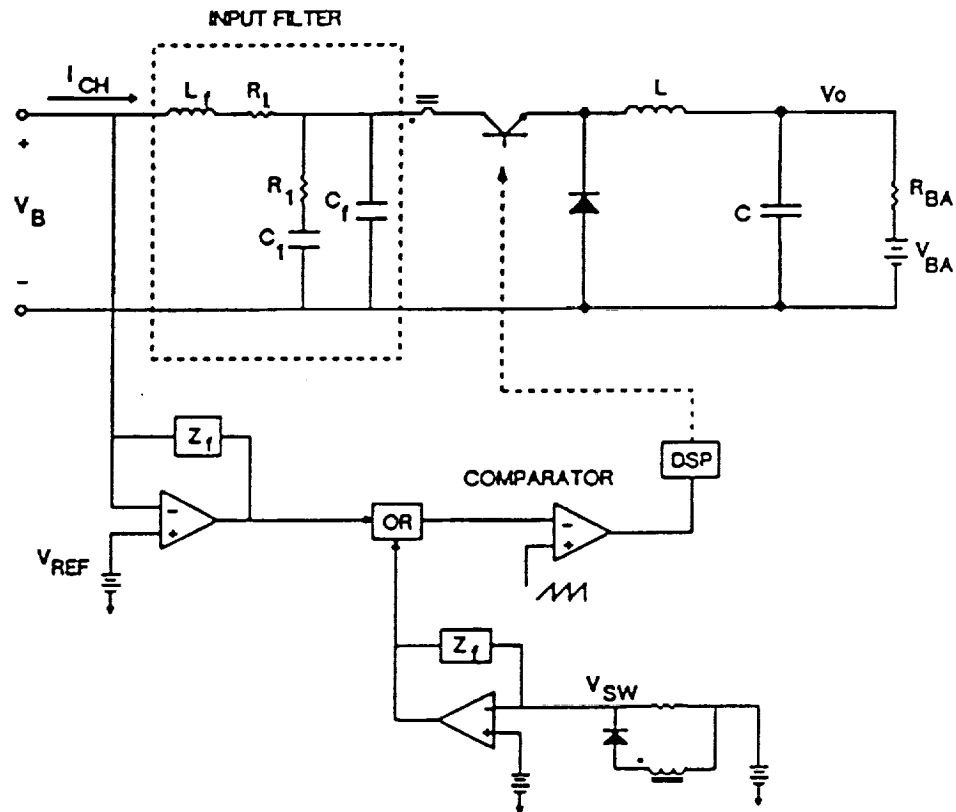

Fig. 5b Simulation for PI compensator

Battery charger circuit (Buck) with input filter



- An input filter is added to smooth the pulsating current drawn by the buck converter
- The circuit can be made to function in two modes.
- In the bus voltage regulation mode, the current is less than the maximum battery charge current and the charger regulates the bus
- When the array has sufficient illumination to provide the maximum charge current, the charger current is limited to this maximum value. The bus voltage rises and the array shunt switching unit regulates the bus

Salient design features for the charger

- **Input filter corner frequency is one decade below the switching frequency to lower the ripple to 1% of output side ripple**
- **An integrator type compensator (2 poles, 2 zeroes) is used.**

$$H_v = \frac{w_m}{s} \frac{(1 + s/w_{z1})(1 + s/w_{z2})}{(1 + s/w_p)}$$

- **The low frequency compensator zero is the dominant pole for bus impedance and determines transient response. It is kept as large as possible. However, placing it beyond the low frequency pole of the power stage can cause conditional instability**
- **The peak overshoot is determined by the ESR of the bus filter capacitor**
- **The second zero approximately determines the settling speed of the system**
- **These transient response features have been verified from the step load simulation**

Simulation for transient response of charger

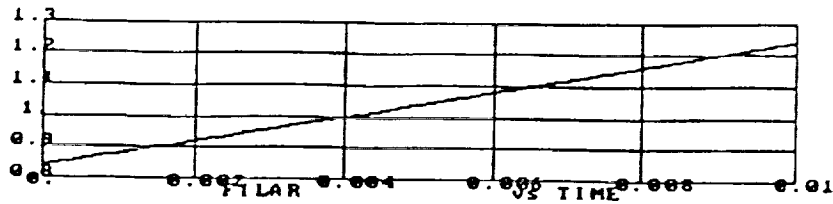

illumination level

[A]

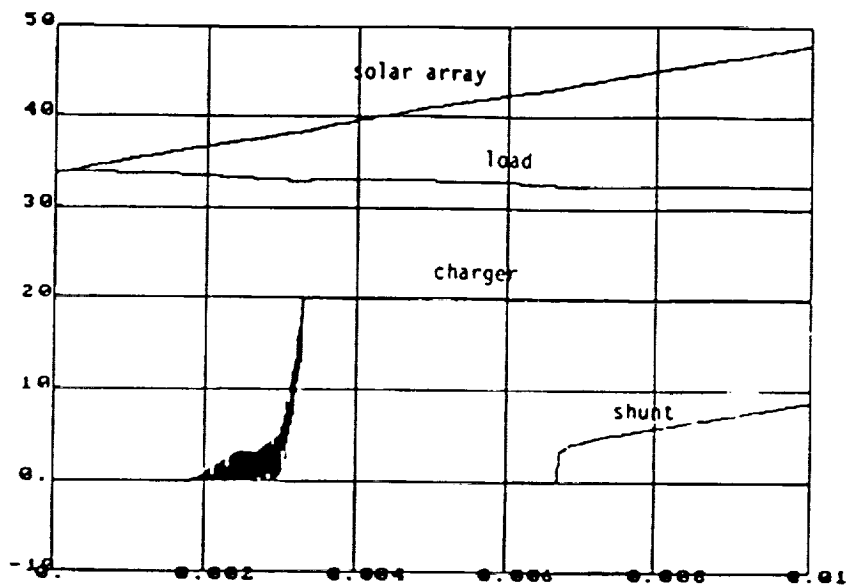

currents

[A]

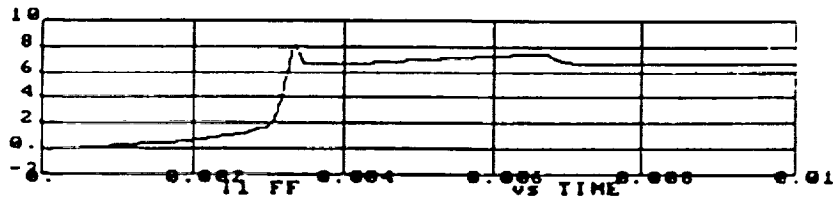

input filter current

[V]

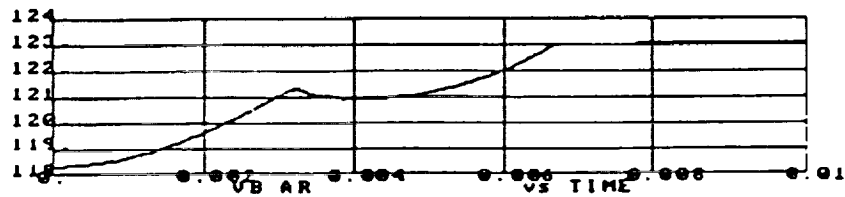

bus voltage

Discharger topology comparison

Topologies considered for discharger

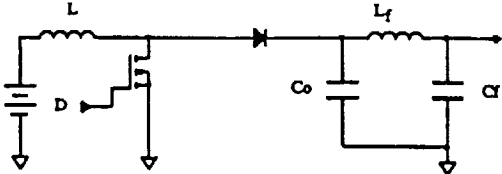

Boost

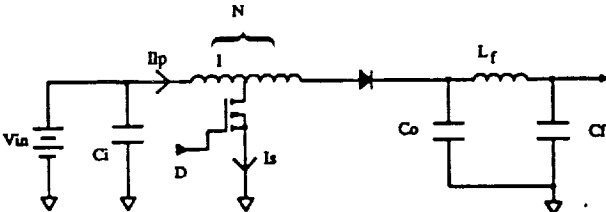

Tapped boost

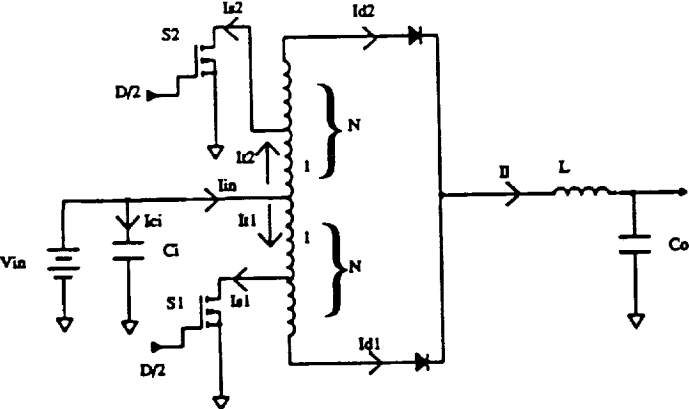

Voltage fed push pull with tapped auto transformer (VFPPTAT)

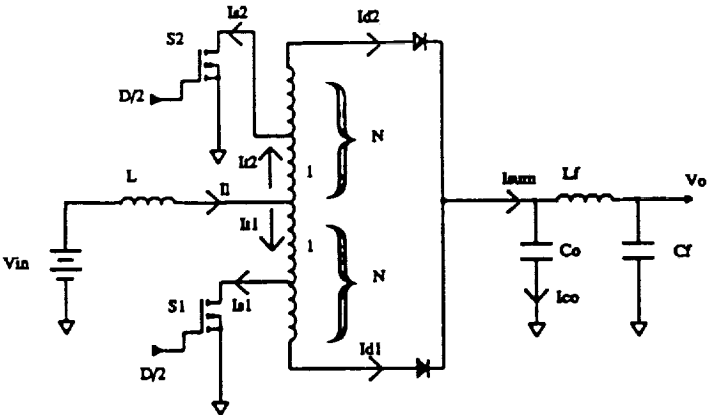

Current fed push pull with tapped auto transformer (CFPPTAT)

	Boost	T-Boost	VFPPTAT	CFPPTAT
Inductor Tap Ratio	1	2	1	1
X-former Tap Ratio	n/a	n/a	3	3
Conversion Frequency	25kHz	25kHz	50kHz	50kHz
Inductance (15% Ripple)	59 μ H	140 μ H ⁺	65 μ H	5.5 μ H
Peak Inductor Current	66 A	42.5 A	19.2 A	66 A
Inductor Energy ($\frac{1}{2} LI_p^2$)	.13 W-S	.13 W-S	.010 W-S	.012 W-S
Max. Duty Cycle	73%	56%	41% *	47% *
Peak Q current	66 A	85 A	57.6 A	49.5 A
RMS Q current	49 A	55 A	37 A	30 A
Peak Q Voltage	120 V	82.5 V	90 V	120 V
Peak Diode Current	66 A	42.5 A	19.2 A	33 A
Peak Diode Voltage	120 V	165 V	210 V	180 V
Input Cap RMS Current	0	18.4 A	19.7 A	0
Output Cap RMS Current	26 A	19 A	0	10.3 A
Pri. Leakage L delta I	0	42.5 A	38.4 A	16.5 A

+ This is the whole inductance. The primary inductance is 35 μ H.

* This is the duty cycle per switch. The duty cycle seen by the inductor is twice.

Results of comparison : choice of discharger topology

- the boost converter is simple, has only one switch, one diode and no transformer, and continuous input current
- it however has disadvantages (specially if the step up ratio is high). These are the RHP zero in the control/output voltage transfer function, high output current stress in the output capacitor, and difficulty in control loop design at high transformation ratios (i.e., high duty ratio)
- the tapped boost allows a lower duty ratio for a given voltage step up, the RHP zero is at a higher frequency and more manageable
- the VFPPTAT is buck derived so it provides continuous output current, well behaved control characteristics, and a lower current stress than the boost or tapped boost
- the VFPPTAT however needs two diodes and two switches, and the circuit is sensitive to transformer saturation
- CFPPTAT has many desirable features such as lowest switch current stress.
- the CFPPTAT however needs two switches, and it is expected that that it may not compare favorably with 2 tapped boost converters operating in parallel and out of phase by 180 degrees
- the tapped boost topology was therefore selected for modeling as discharger

Simulation waveforms for tapped boost discharger model

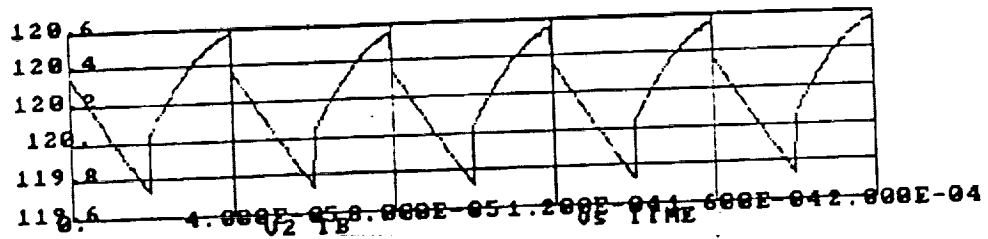

a) First Stage Capacitor Bank Voltage

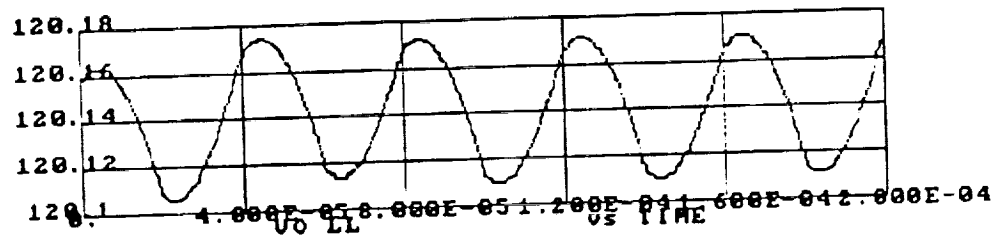

b) Bus Voltage

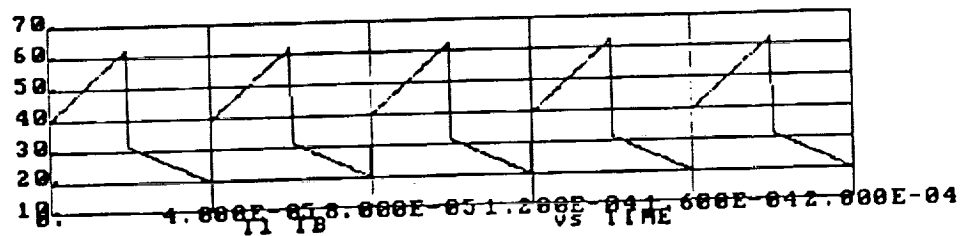

c) Input Current

Transient response of discharger to a 1 A step load current change

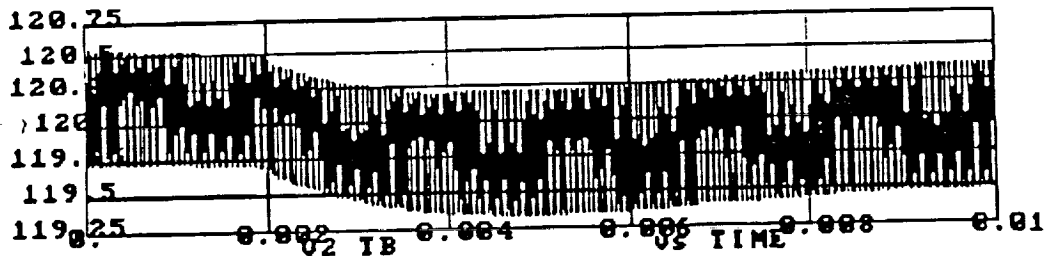

a) First Stage Capacitor Bank Voltage

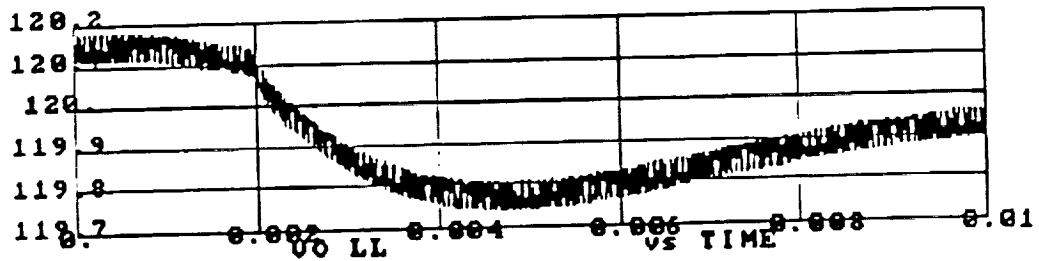

b) Bus Voltage

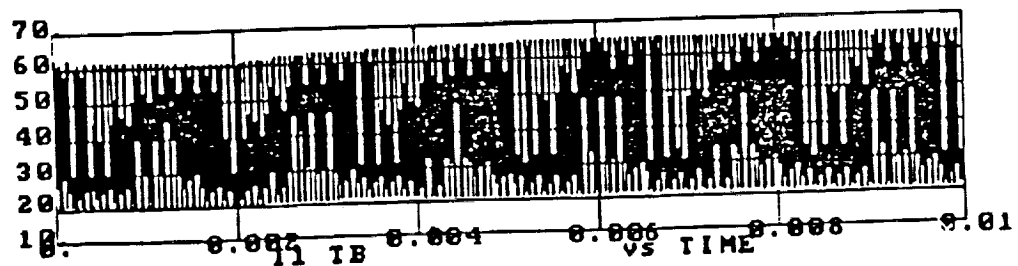

c) Input Current

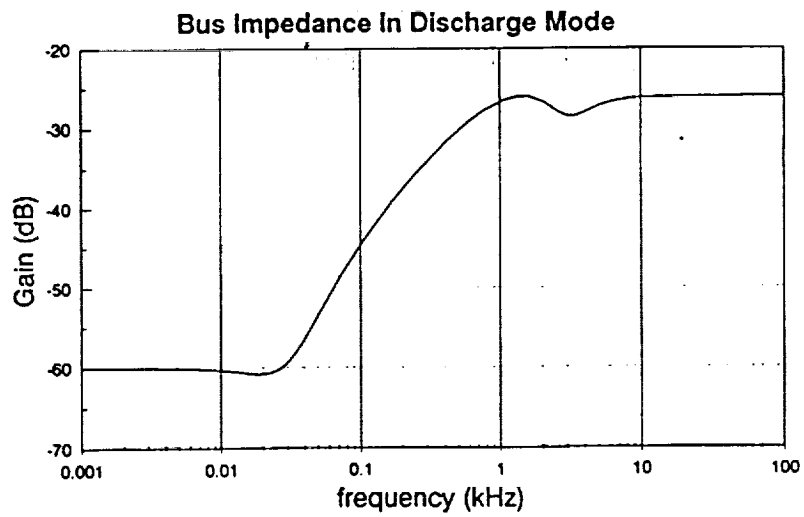
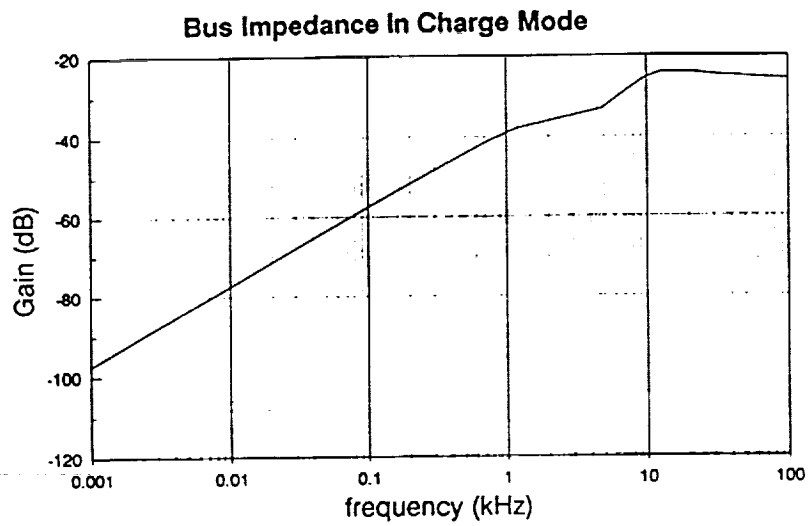
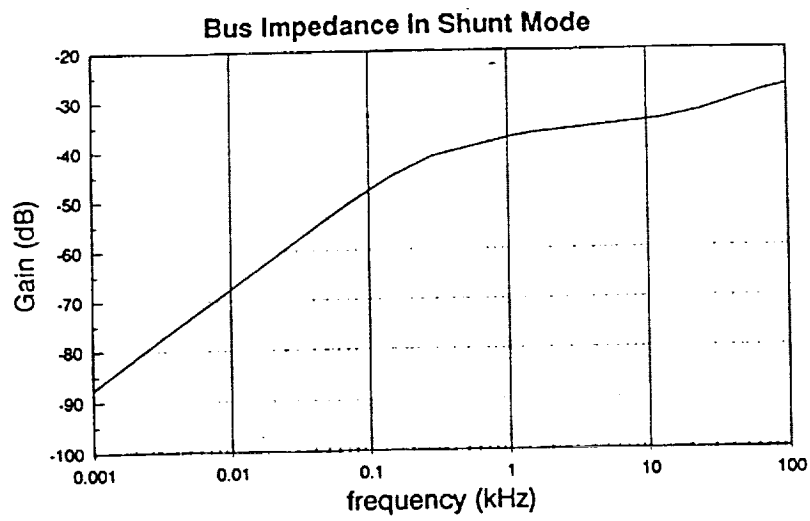

Comparison of bus impedances in different modes

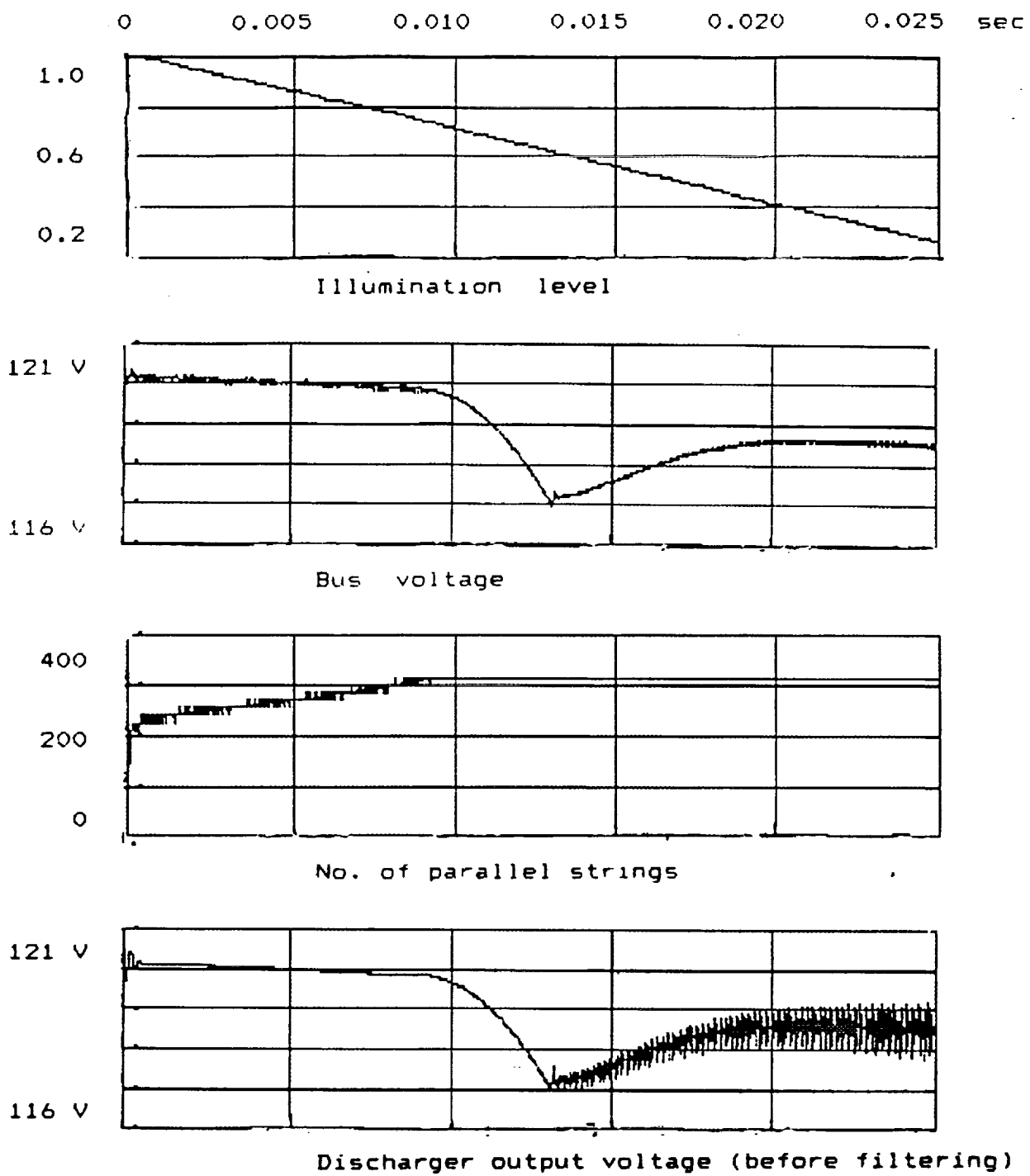

Fig. 4.1-5 Sunlight to eclipse transition

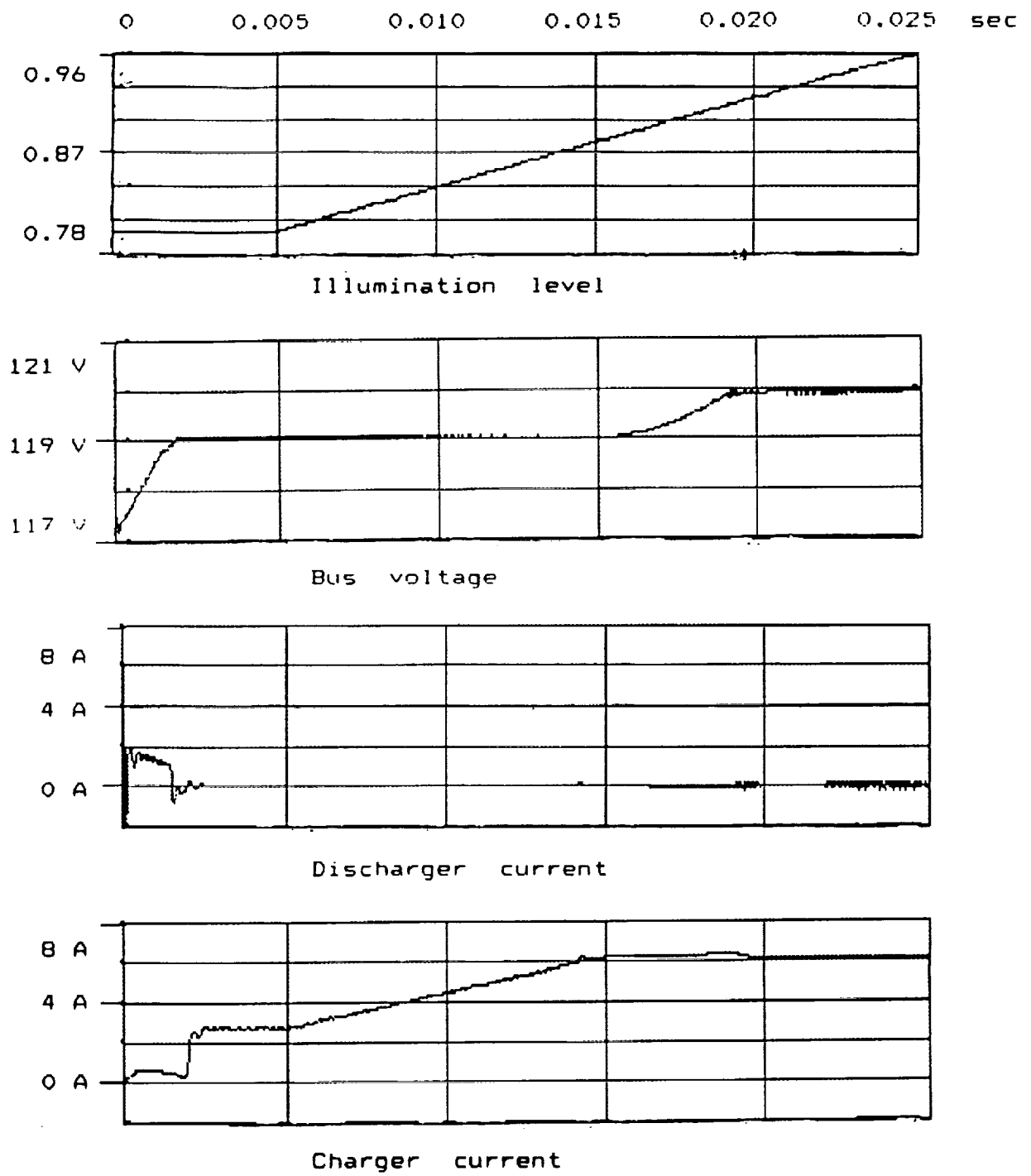

Fig. 4.1-6 Eclipse to sunlight transition

Proposed future work : Hardware system testbed

Objectives :

- **To enable verification and improvement of existing EASY5 computer models**
- **To provide experimental confirmation of analytical design procedures**

Proposed hardware work :

The following are to be designed, built and tested. The designs will be optimized by VPEC's power converter optimization (CADO) software.

- **battery charger**
- **battery discharger (boost, and an alternate topology)**
- **mode controller**

These are to be tested with :

- **a simple solar array simulator**
- **battery simulator**
- **load bank**

These will allow verification of simulations for many of the system modes. Future work could incorporate a solar array shunt switching unit for verification of the shunt mode.

References :

- [1] J.Lee, S.Kim, B.H. Cho, and F.C. Lee,, "Computer-aided modeling and analysis of power processing systems (CAMAPPS) - Phase II", Final report prepared for NASA/Goddard, VPI&SU, 1987
- [2] B.H Cho, J.R. Lee, "Design, analysis and simulation of the main bus dynamics of spacecraft power systems," IECEC Conference proceedings, 1988
- [3] J. Lee, "Analysis and simulation of dynamics of spacecraft power systems," (Dissertation), VPI&SU, 1989
- [4] A. Patil, S. Kim, D. Sable, B. Cho, F.C. Lee, "Modeling of space platform power distribution," Final report prepared for Fairchild Space Company, VPI&SU, 1989
- [5] F.S. Tsai and F.C. Lee, "Computer modeling and simulation of a 20 kHz AC distribution system for the space station," Report prepared for NASA Lewis Research Centre, VPI&SU, 1987

ANALYSIS AND DESIGN OF A HIGH POWER, DIGITALLY CONTROLLED SPACECRAFT POWER SYSTEM

QUARTERLY PROGRESS REVIEW

for

**NASA GODDARD SPACE FLIGHT CENTER
GREENBELT, MD**

MAY 1, 1990

PREPARED BY

**D. SABLE, A. PATIL, T. SIZEMORE, S. DEUTY, B.H.
CHO AND F.C. LEE**

**VIRGINIA POWER ELECTRONICS CENTER
VIRGINIA POLYTECHNIC INSTITUTE
AND STATE UNIVERSITY
BLACKSBURG, VA 24061**

PRESENTATION OUTLINES

- 1. Space Platform Power System Modeling**
 - 1.1 Battery discharger analysis & design** DS
 - 1.2 EASY5 modeling for battery ORU** TS/AP
 - Battery charger/discharger mode control**

- 2. Space Platform Power System Testbed**
 - 2.1 Battery discharger design**
 - 2.1.1 Four-module boost** DS
 - 2.1.2 Voltage-fed push-pull autotransformer** SD
 - 2.2 Battery charger design** TS

- 3. Discussion**

1. SPACE PLATFORM

POWER SYSTEM MODELING

NASA/GSFC Space Platform Modeling
 Project Schedule
 Phase II (Ending 8/31/90)

4/26

△	PLAN
△	CHANGE
▲	COMPLETE

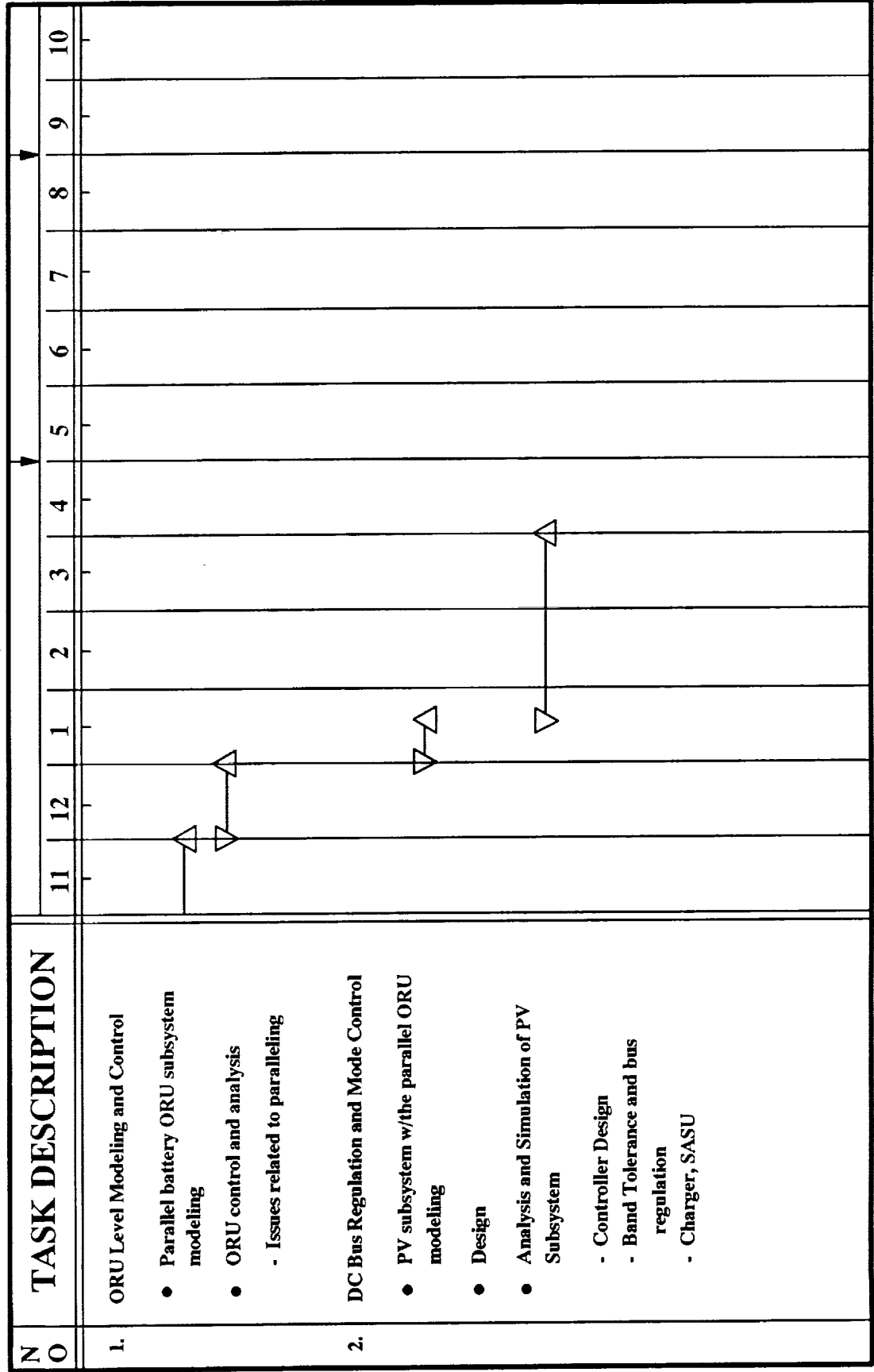

BATTERY DISCHARGER ANALYSIS

PROGRESS SINCE LAST MEETING

- 1) TRADEOFF STUDY HAS BEEN FURTHER REFINED
 - USE OF POLYPROPYLENE INSTEAD OF POLYCARBONATE CAPS
 - INDUCTOR CORE LOSS DATA HAS BEEN UPDATED
 - TWO DIODES IN SERIES EMPLOYED FOR REDUNDENCY

- 2) MULTI-MODULE BOOST CONVERTER CONTROL LOOP HAS BEEN REFINED
 - DAMPING PROVIDED FOR SECONDARY OUTPUT FILTER
 - HIGHER GAIN MARGIN PROVIDED

- 3) DESIGNS HAVE BEEN SELECTED FOR HARDWARE BUILD
 - 45 KHZ, 97% EFFICIENT MULTI-MODULE BOOST CONVERTER
 - 40 KHZ, 96% EFFICIENT VOLTAGE-FED AUTOTRANSFORMER CONVERTER

BATTERY DISCHARGER TRADEOFF STUDY

BOOST CONVERTER

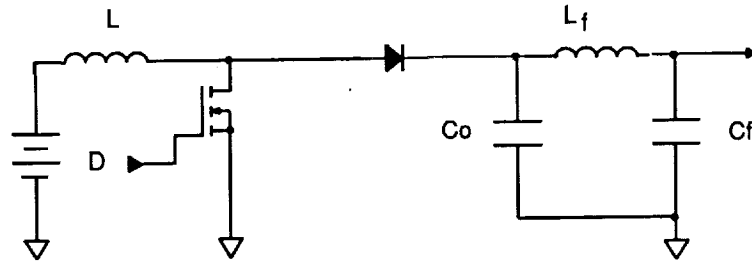

VOLTAGE-FED, PUSH-PULL WITH TAPPED AUTOTRANSFORMER (VFPPAT) CONVERTER

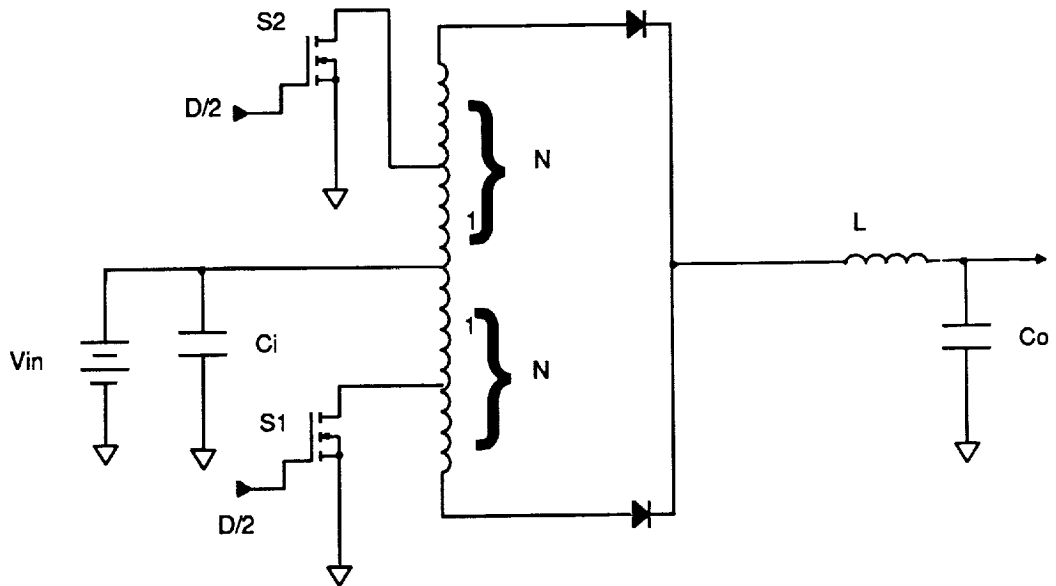

MULTI-MODULE/MULTI-PHASE CONCEPT

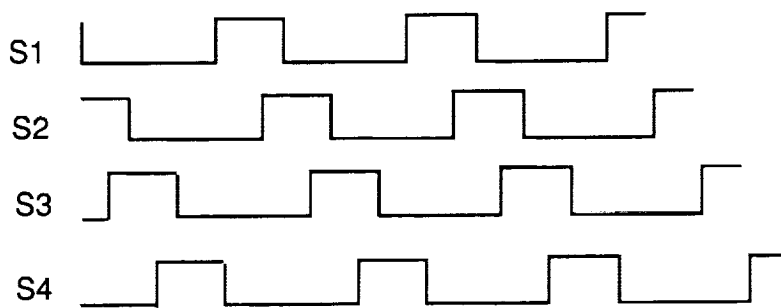
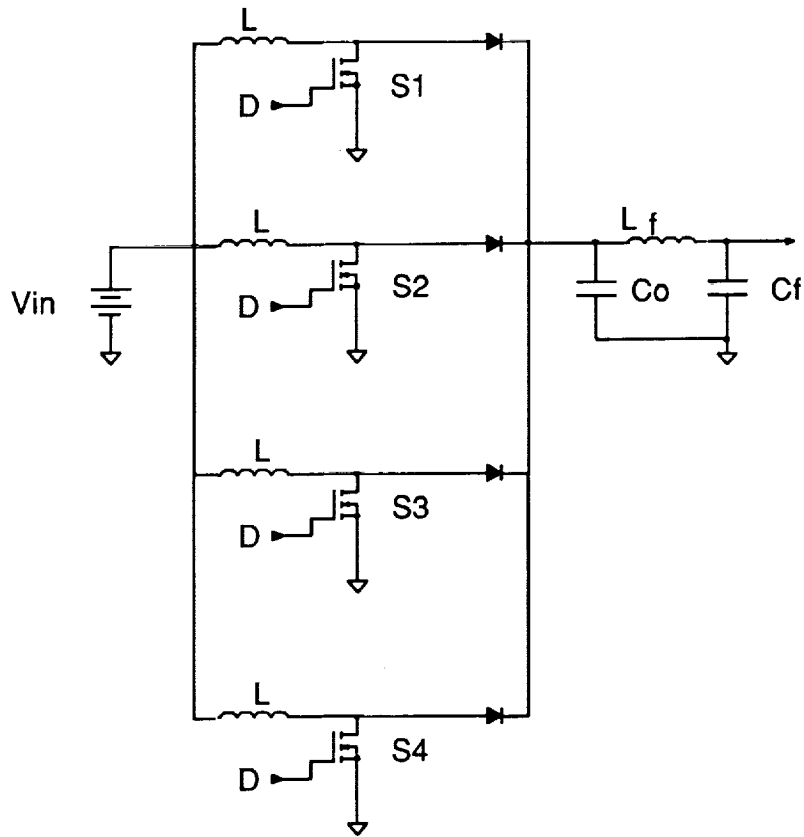

DRAMATIC REDUCTION OF OUTPUT CAP. STRESS
 BENEFICIAL FOR THE BOOST CONVERTER
 MUCH FASTER TRANSIENT RESPONSE POSSIBLE
 CAN BE MORE RELIABLE
 CLOSED-LOOP CURRENT SHARING
 $N+1$ REDUNDANCY

OUTPUT CAPACITOR RIPPLE CURRENT

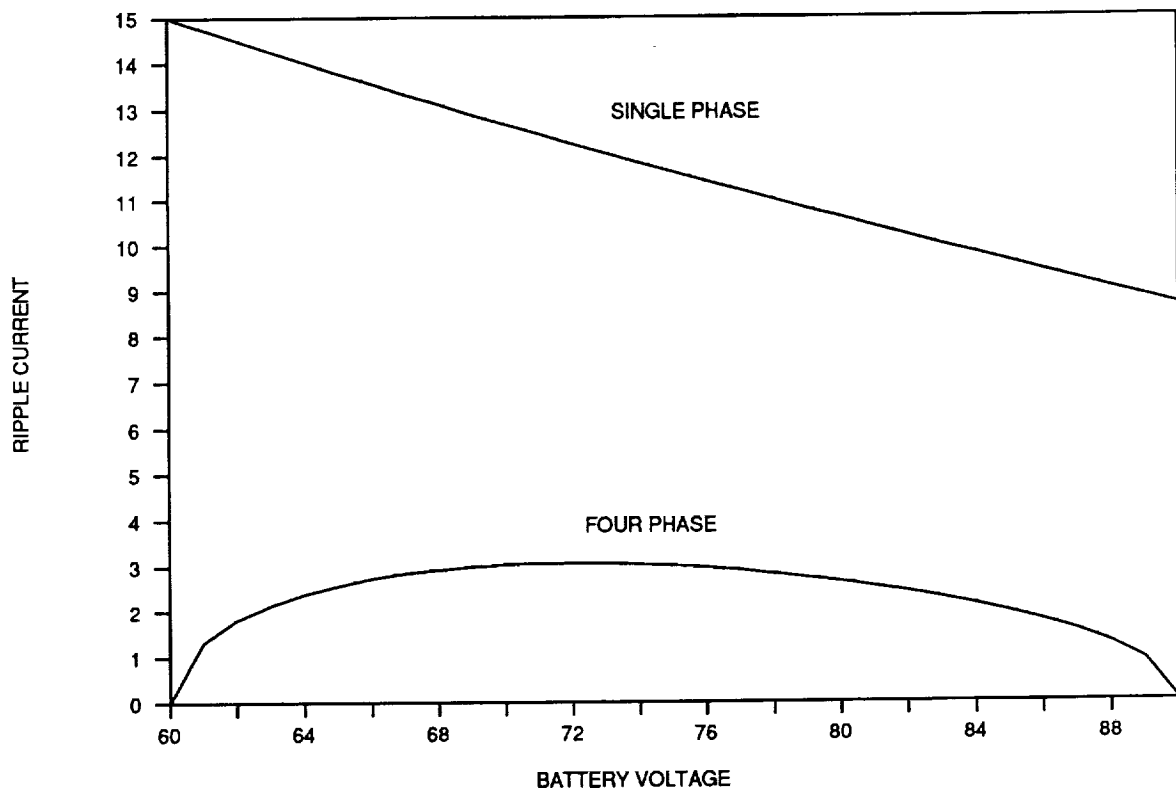

SINGLE-MODULE BOOST DESIGNS

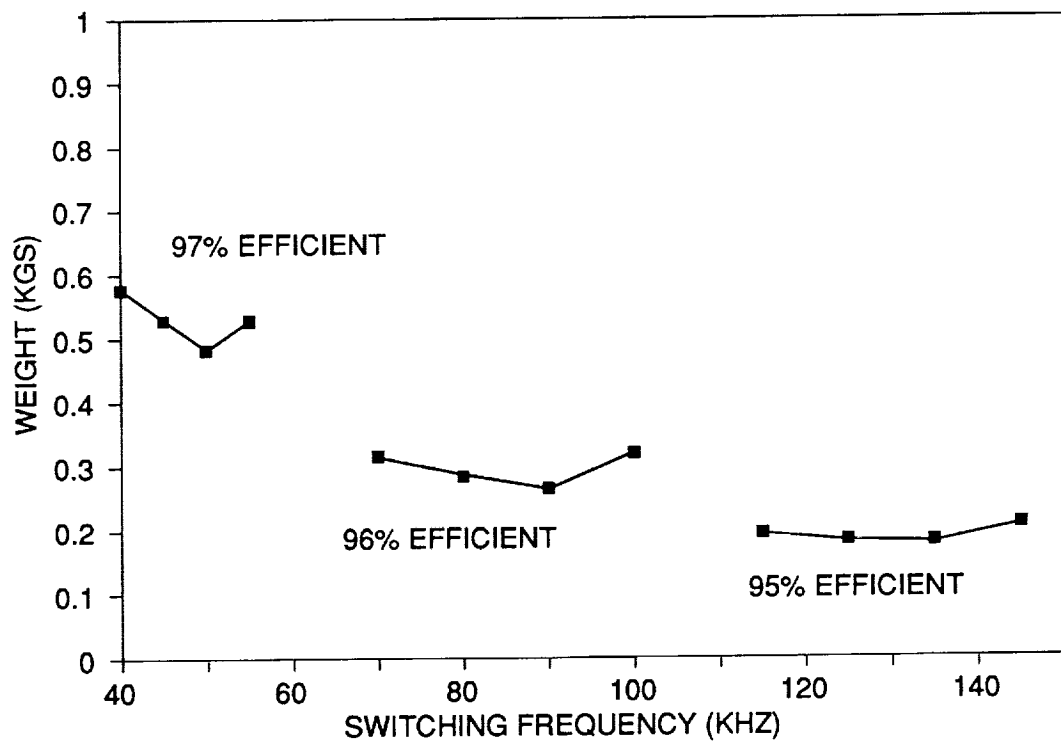

VOLTAGE-FED AUTOTRANSFORMER DESIGNS

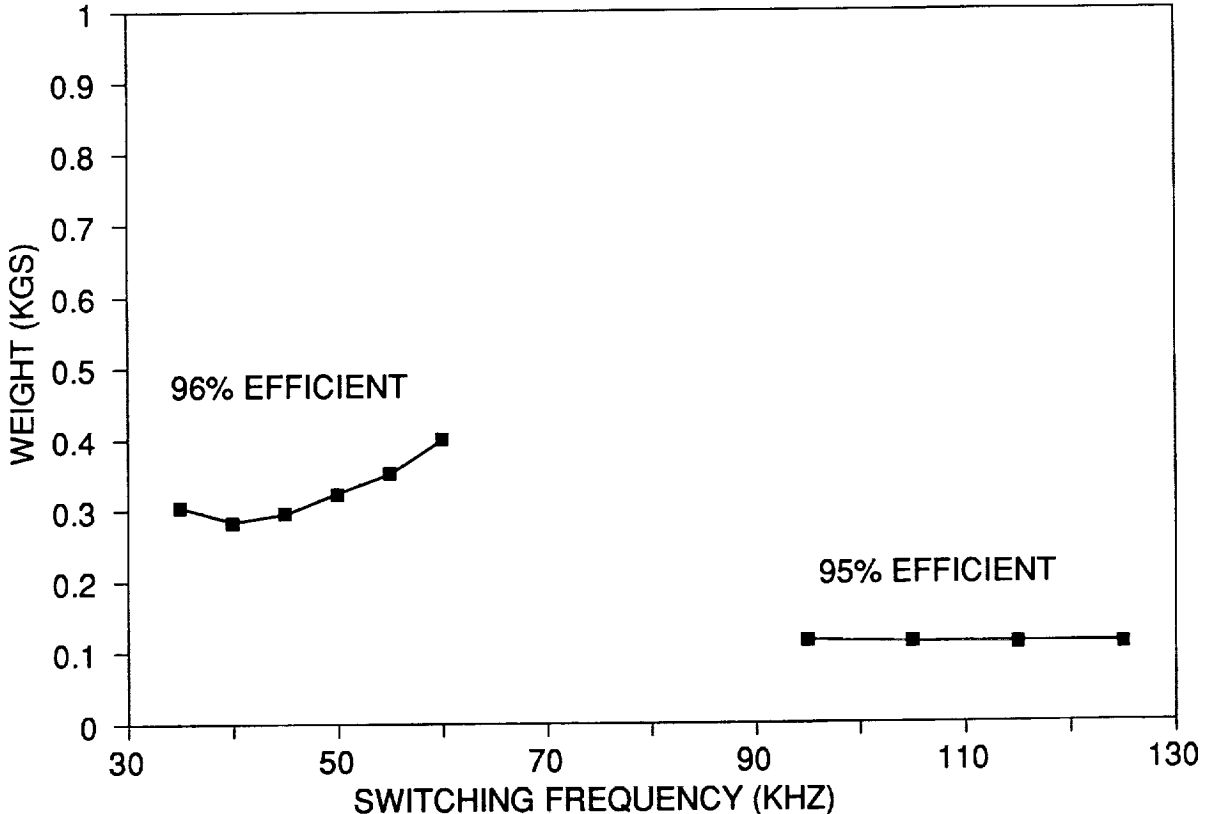

FOUR MODULE BOOST DESIGNS

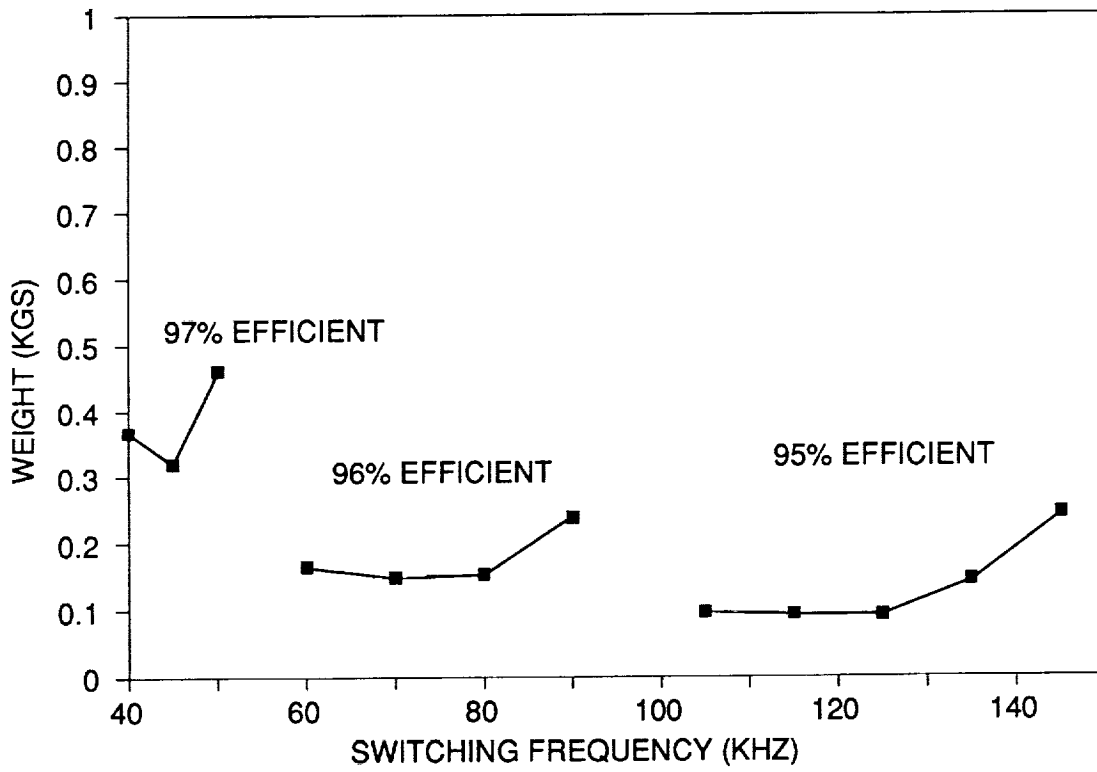

FOUR MODULE BOOST CONTROL CIRCUIT

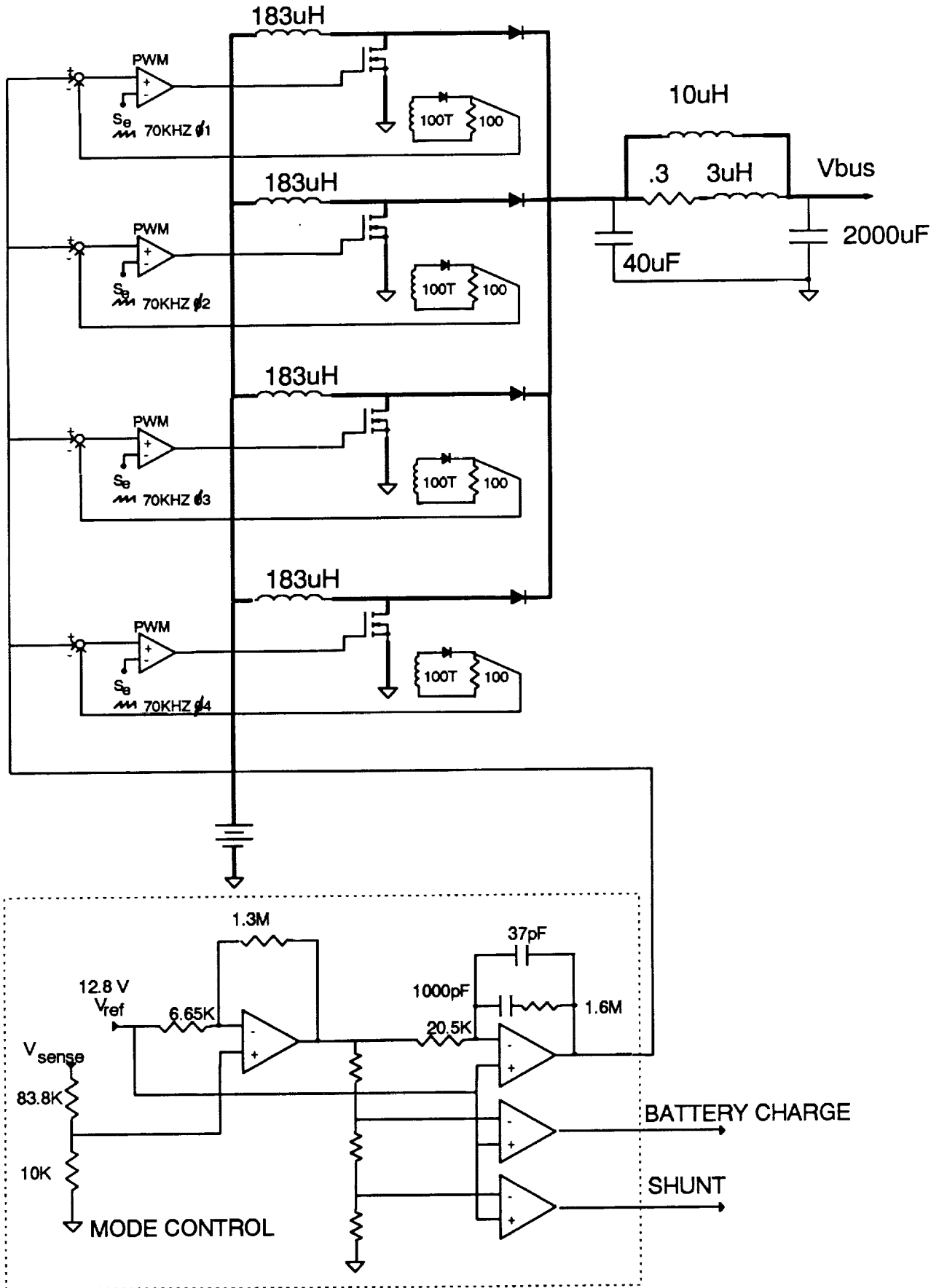

BOOST CONVERTER

Date/Time run: 04/28/90 11:35:23

Temperature: 27.0

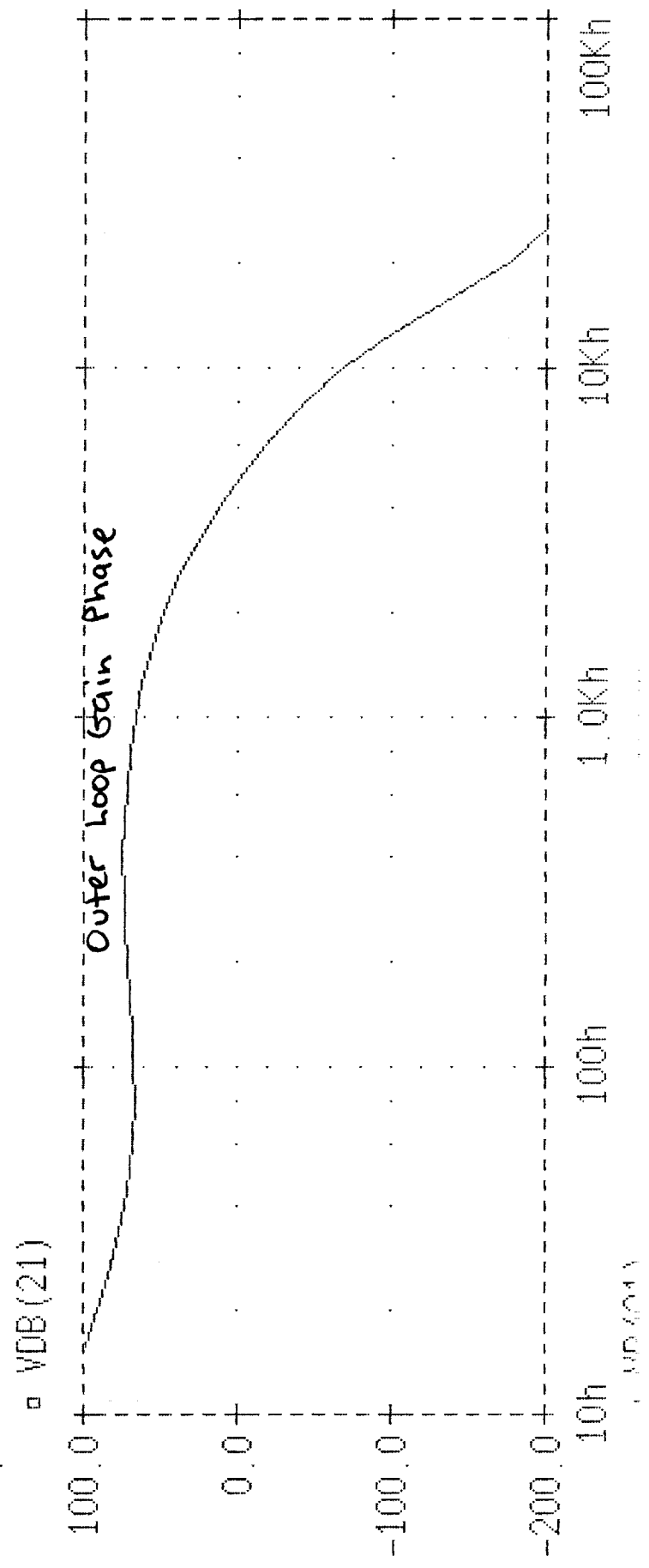
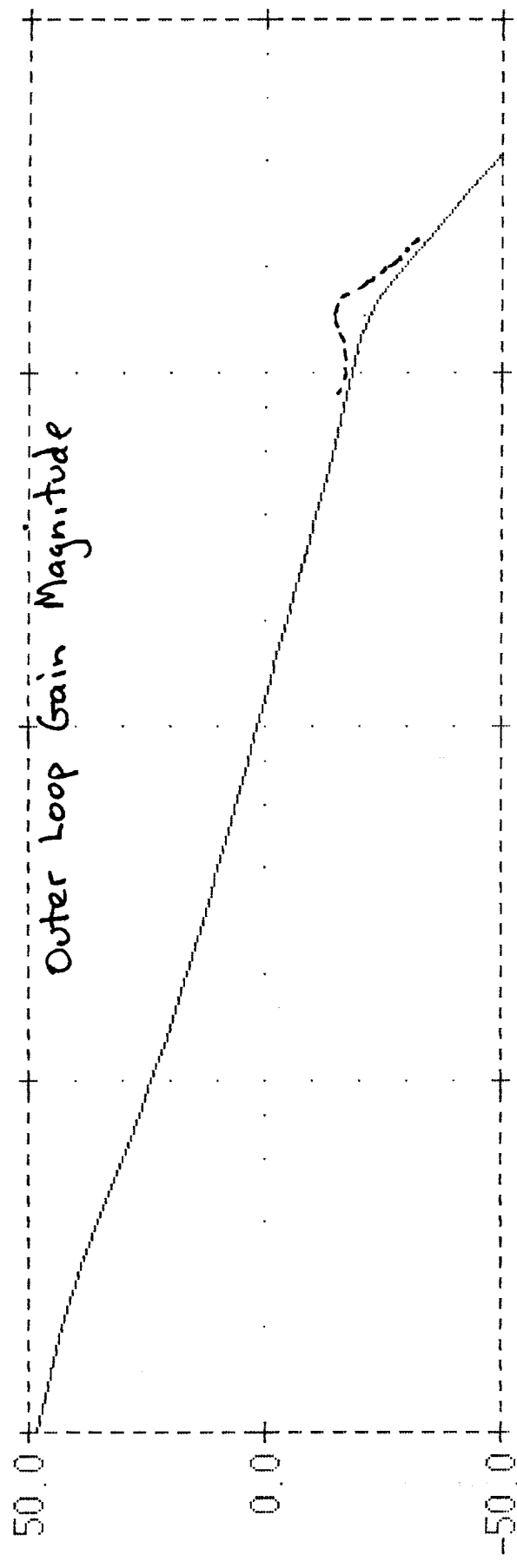

BOOST CONVERTER

Date/Time run: 04/28/90 11:47:46

Temperature: 27.0

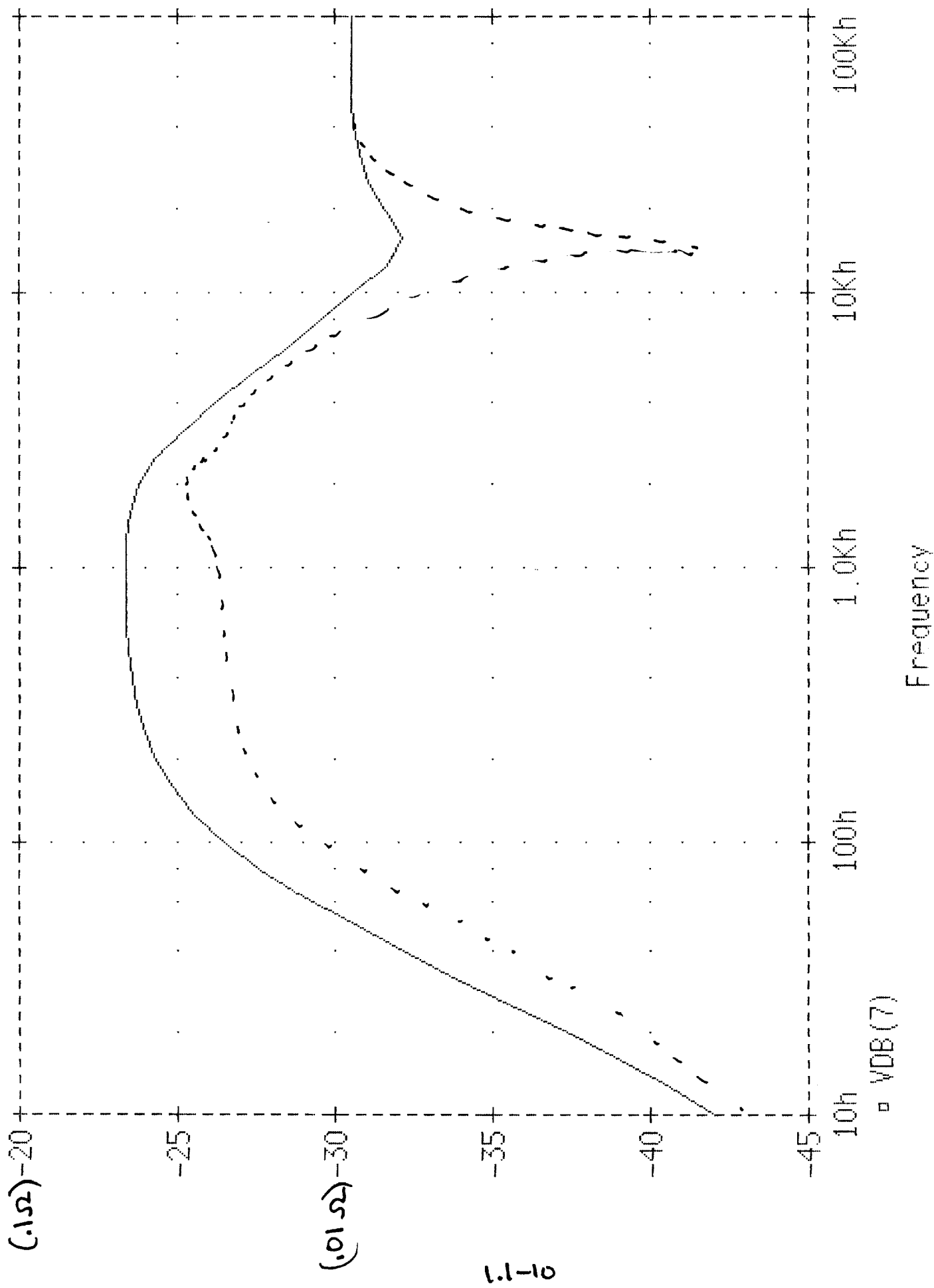

BOOST CONVERTER

Date/Time run: 04/28/90 11:53:36

Temperature: 27.0

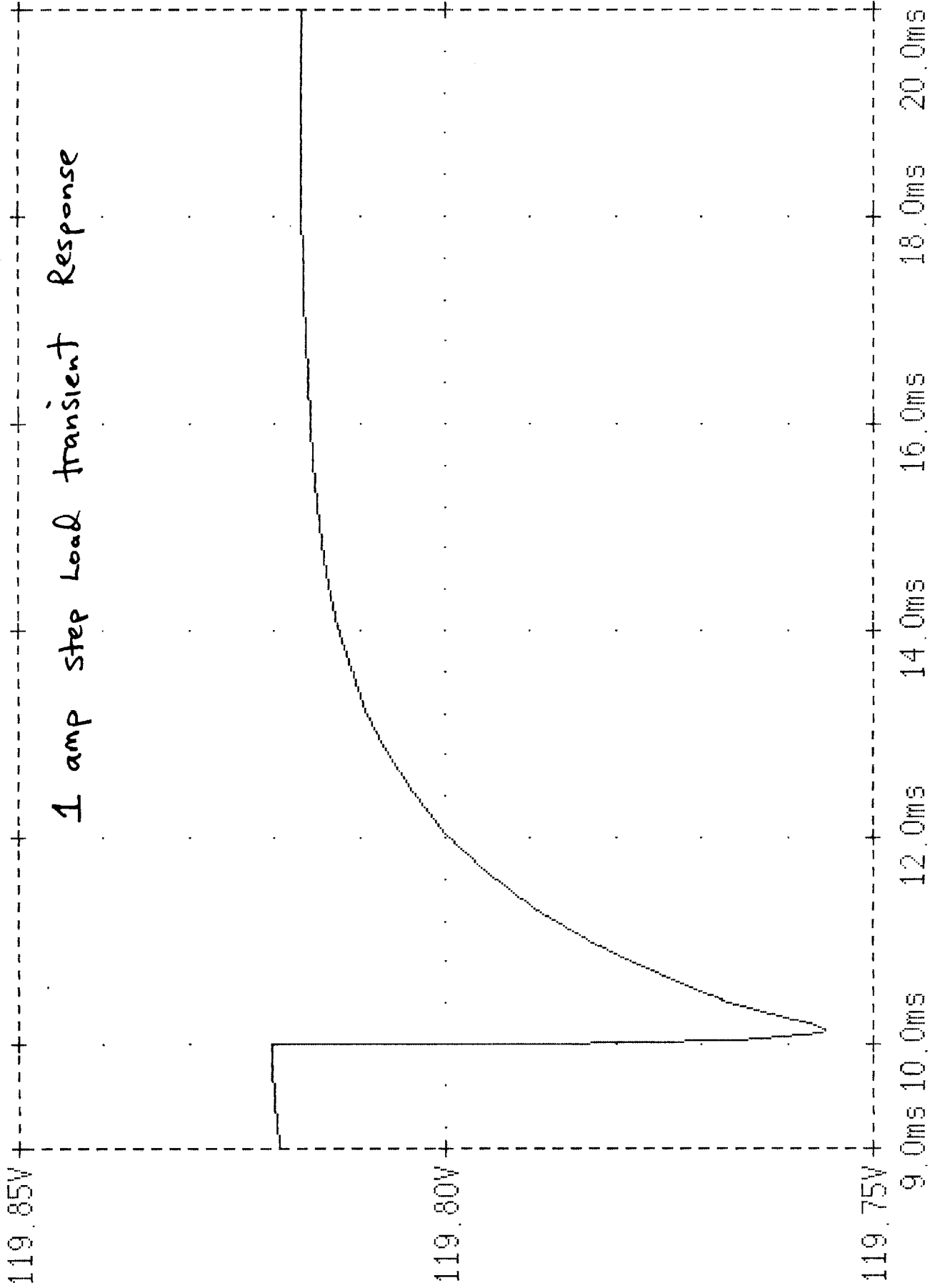

ORU MODELLING WITH EASY5

SUMMARY AND REVIEW

- PARALLEL DISCHARGER CONTROL
 - * BATTERY VOLTAGE IMBALANCE & CURRENT SHARING
 - * 2'nd STAGE LC FILTER
 - * EFFECT OF PARALLELING ON STABILITY
- PARALLEL CHARGER CONTROL

NEW EASY5 MODELS

- MODE CONTROLLER (PCU)
- FOUR PHASE MODULATOR

ORU POWER SYSTEM CONTROL

SPACE PLATFORM POWER SYSTEM

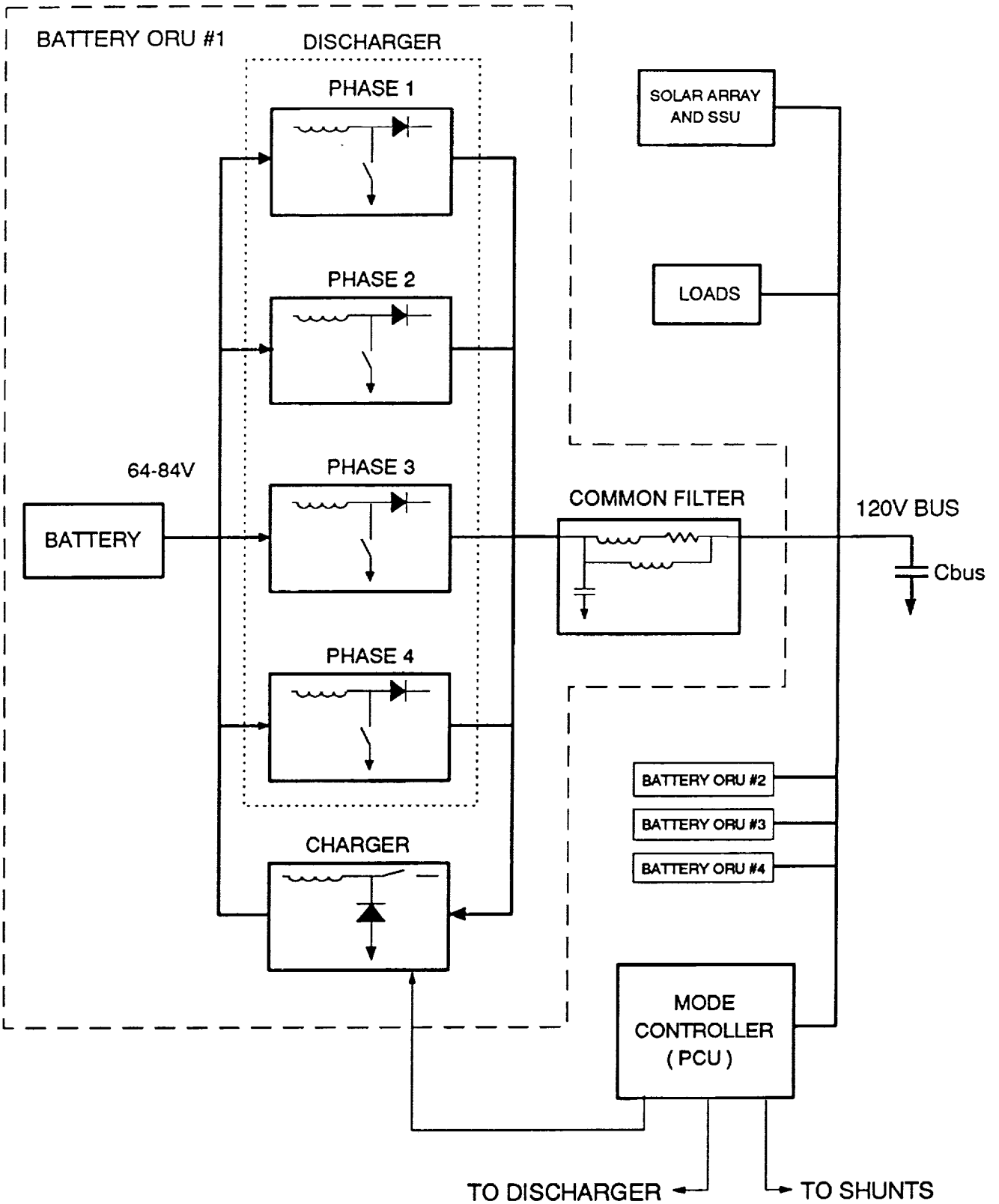

PARALLEL DISCHARGER CONTROL

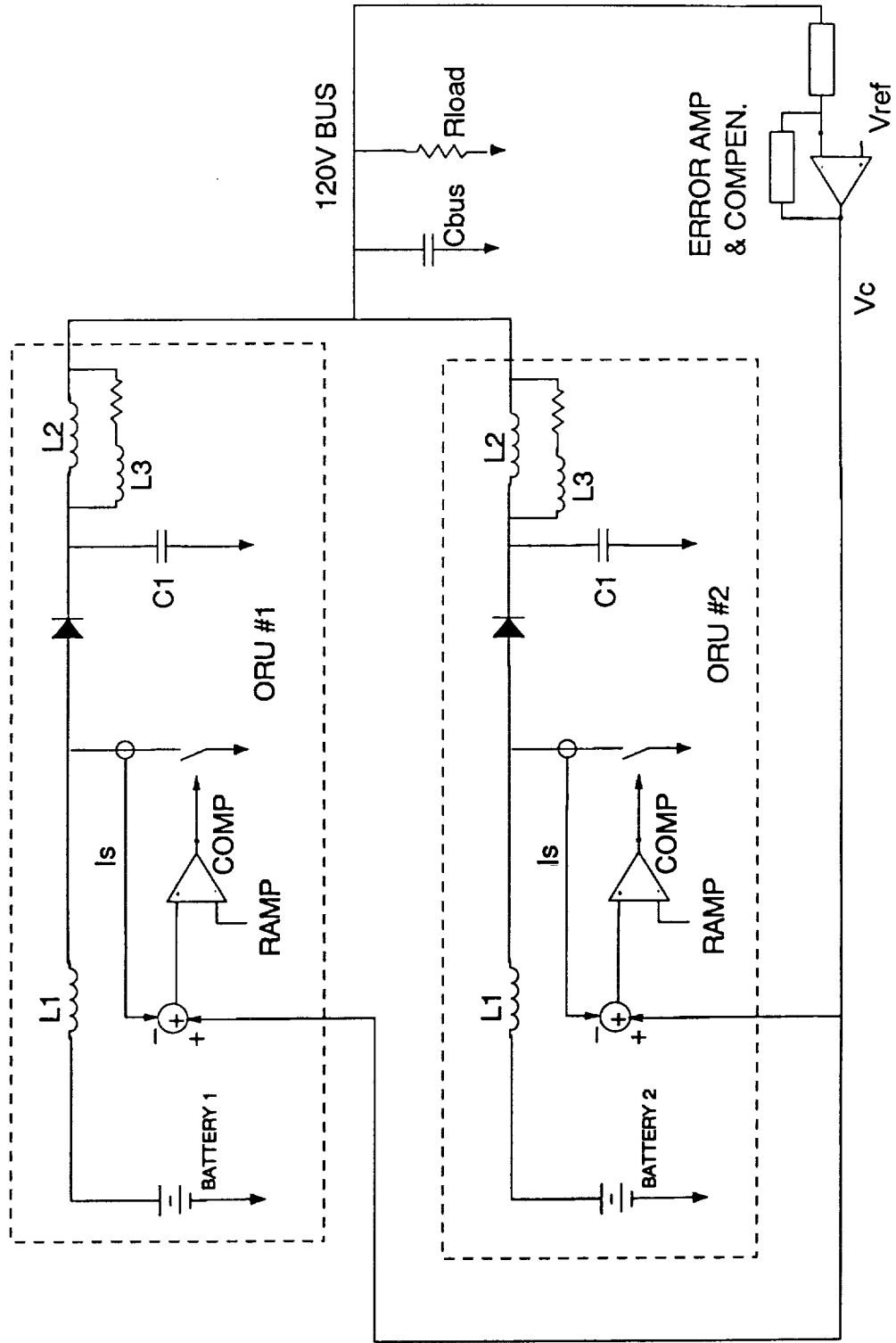

DC ANALYSIS FOR PARALLEL DISCHARGERS

- * BATTERY VOLTAGE IMBALANCE

- CHARGE IMBALANCE
- SHORTED CELL

- * CURRENT MODE CONTROL : CURRENT SHARING

- BATTERY CURRENT = INDUCTOR CURRENT
- PEAK CURRENT DETECTION

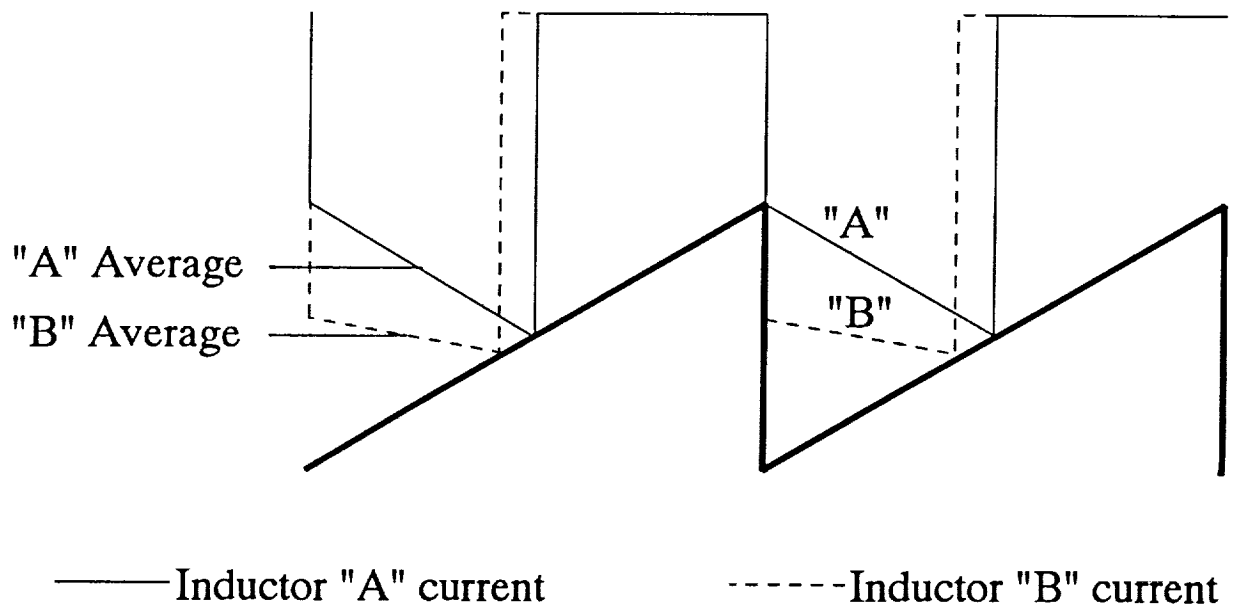

Battery "B" voltage > Battery "A" voltage

Result: Battery "B" average discharge current is higher,
voltage imbalance corrected .

TWO STAGE LC FILTER

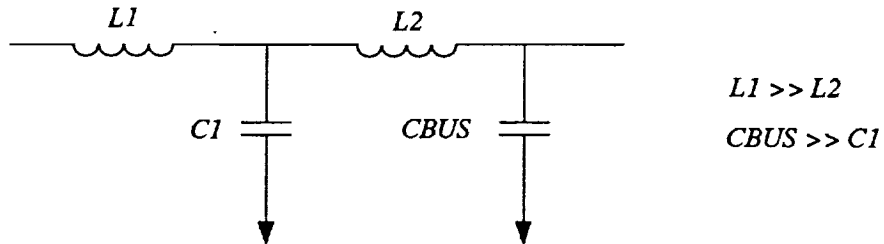

CHARACTERISTIC EQUATION

(Note: $C2 = CBUS$)

$$s^4 + s^2 \left[\frac{1}{L2 C1} + \frac{1}{L2 C2} \right] + \frac{1}{L1 L2 C1 C2} = 0$$

$$\left[s^2 + \frac{1}{L1 (C1 + C2)} \right] \left[s^2 + \frac{1}{L2 C1} + \frac{1}{L2 C2} \right] \approx 0$$

RESONANT FREQUENCIES

$$\omega_{o1} = \frac{1}{\sqrt{L1 (C1 + C2)}} \approx \frac{1}{\sqrt{L1 C2}}$$

$$\omega_{o2} = \frac{1}{\sqrt{L2 \left[\frac{C1 C2}{C1 + C2} \right]}} \approx \frac{1}{\sqrt{L2 C1}}$$

PARALLEL CONVERTERS WITH TWO STAGE FILTERS

(BUCK OR BOOST EQUIVALENT)

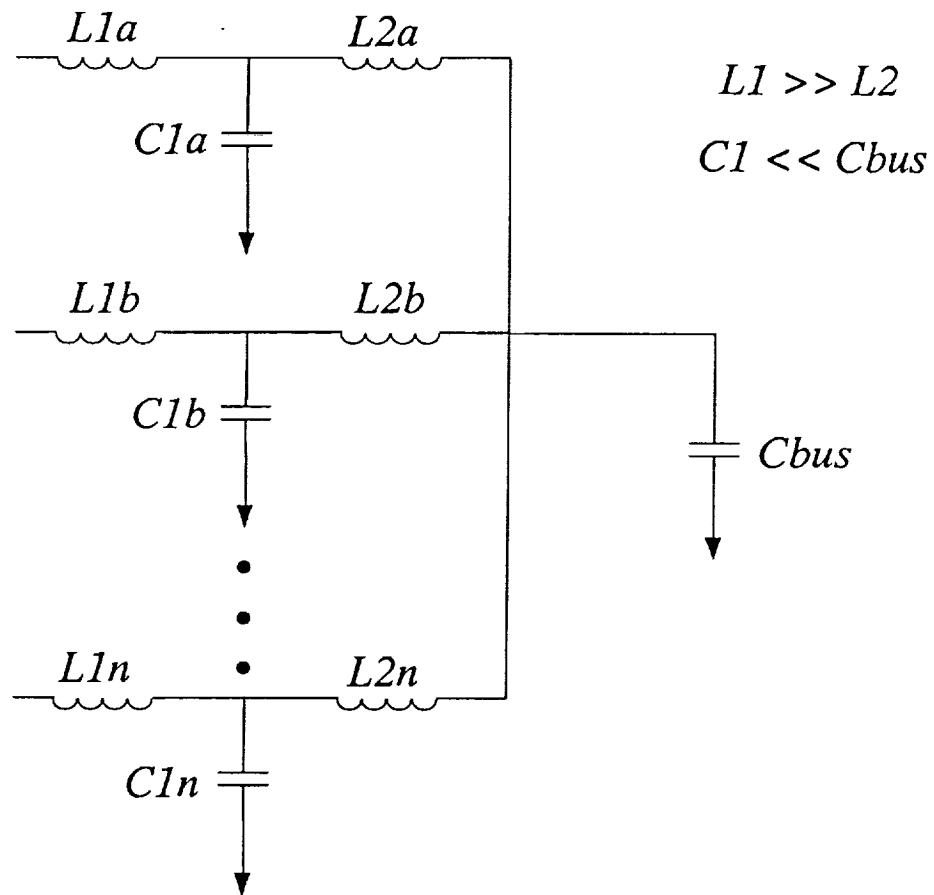

$$W_{o1} = \frac{1}{\sqrt{\frac{L1}{n} (n C1 + Cbus)}} \approx \frac{\sqrt{n}}{\sqrt{L1 Cbus}}$$

$$W_{o2} = \frac{1}{\sqrt{\frac{L2}{n} \left[\frac{n C1 Cbus}{n C1 + Cbus} \right]}} \approx \frac{1}{\sqrt{L2 C1}}$$

PARALLEL CHARGER MODEL

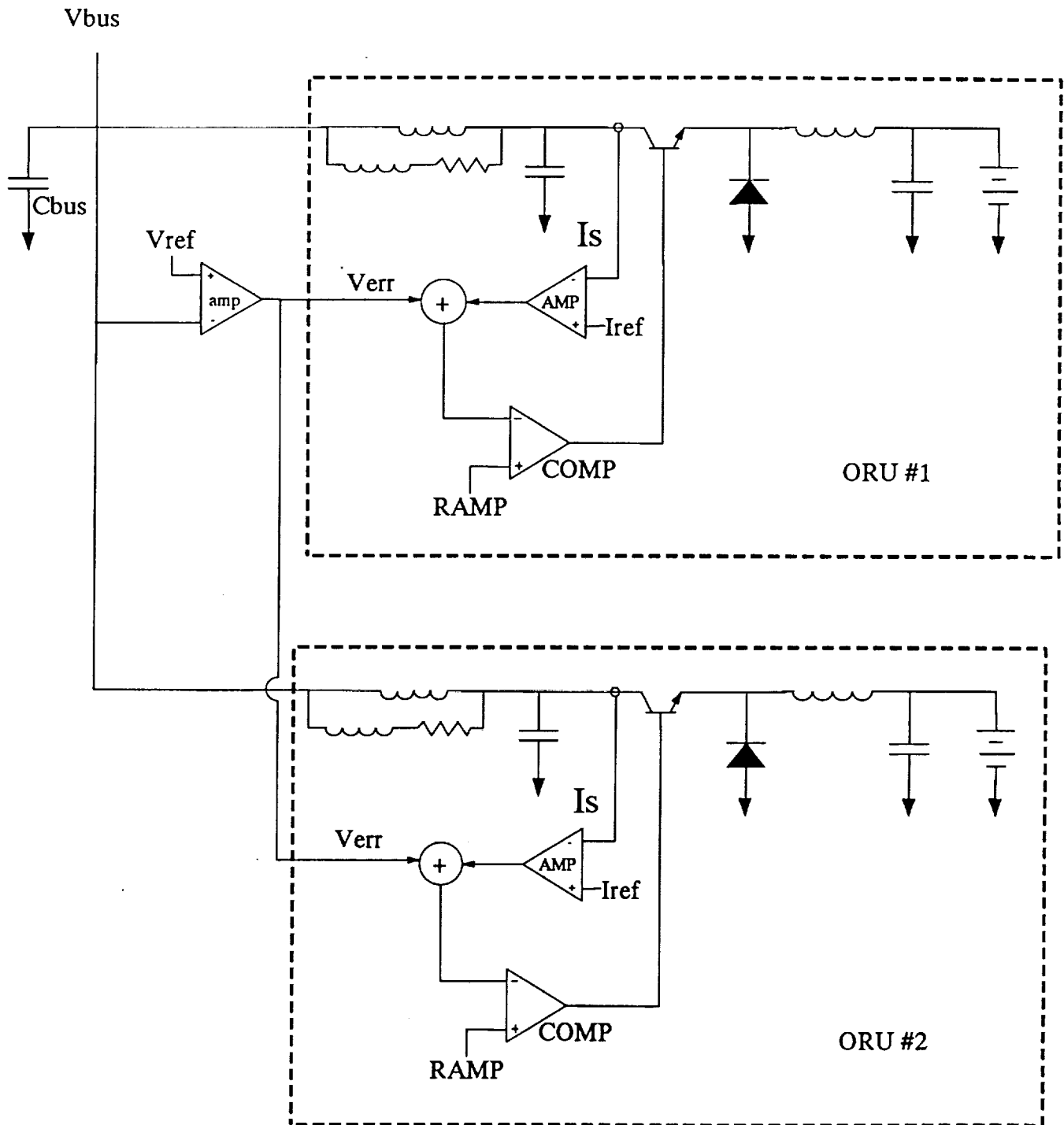

EASY5 FOUR PHASE MODULATOR MODEL

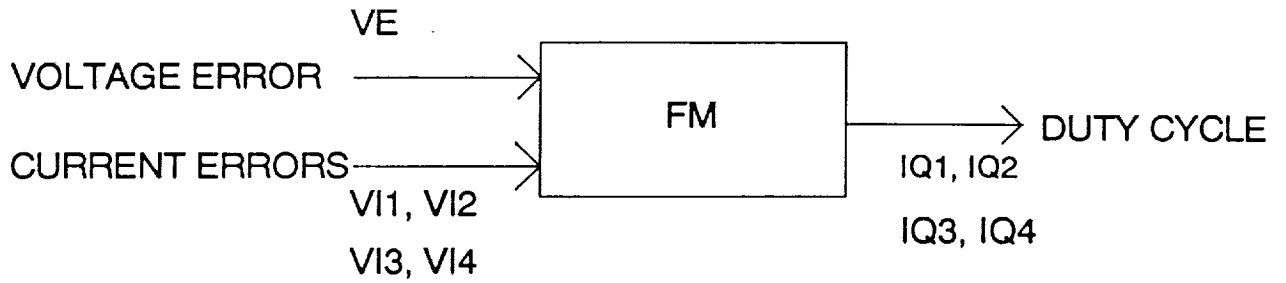

THE FOUR MODULATOR RAMPS ARE ALL SHIFTED BY 90 DEG :

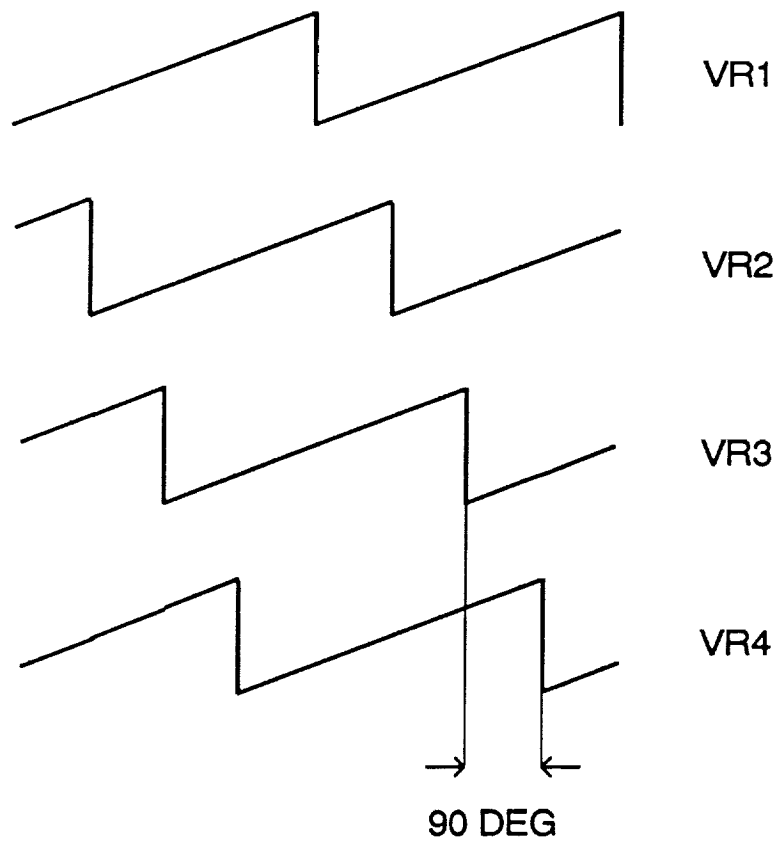

EASY5 MODE CONTROLLER MODEL

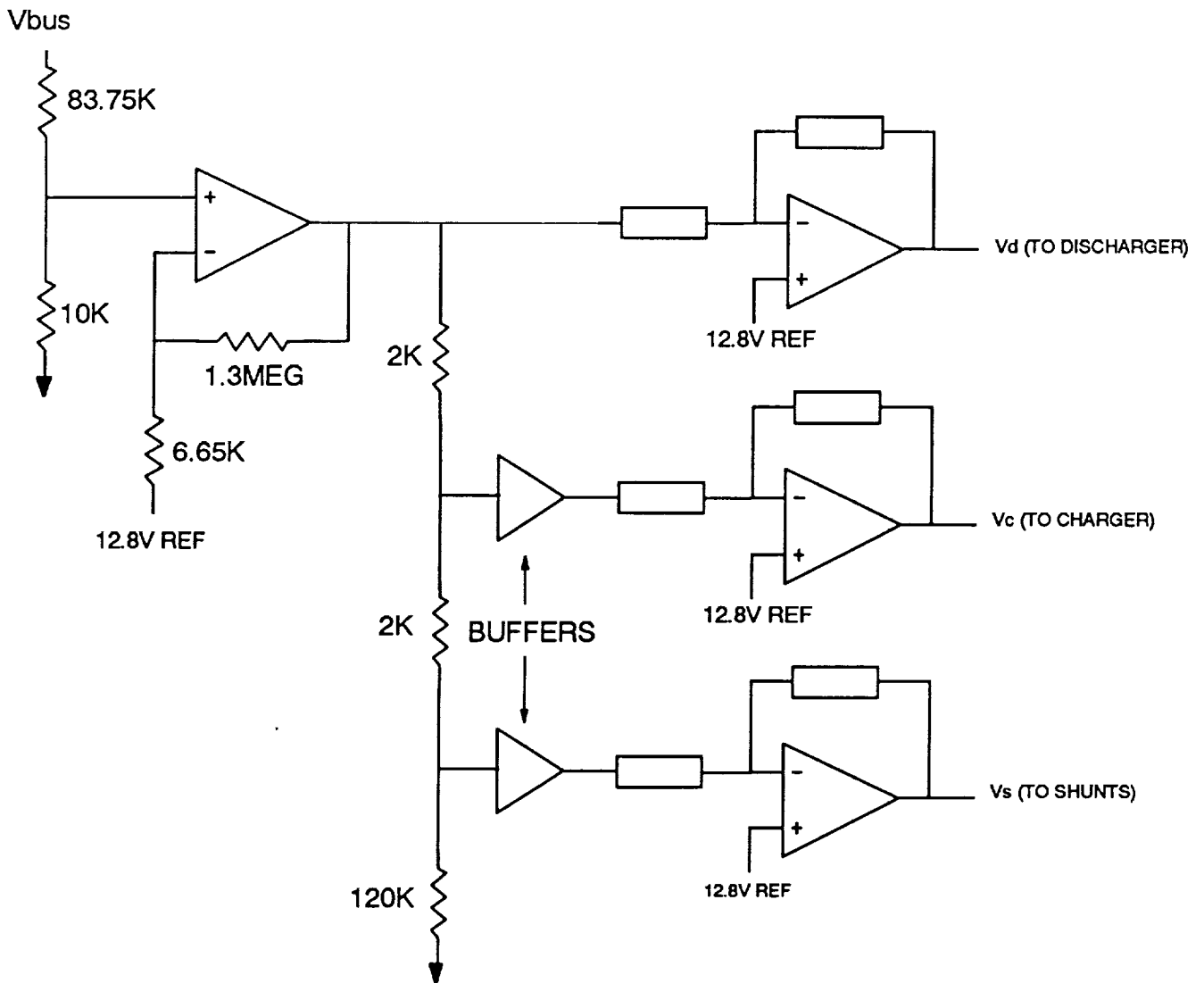
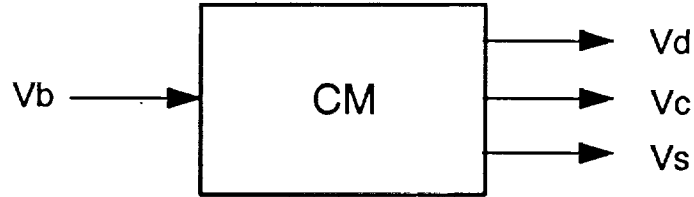

NOTE: ALL OP-AMPS HAVE ONE COMMON 12.8V REFERENCE

MODELING AND SIMULATION OF POWER SYSTEM

- System block diagram
- Operation of solar array
- Operation of 4-module discharger
- Operation of charger
- Mode transition from array to discharger

SYSTEM BLOCK DIAGRAM

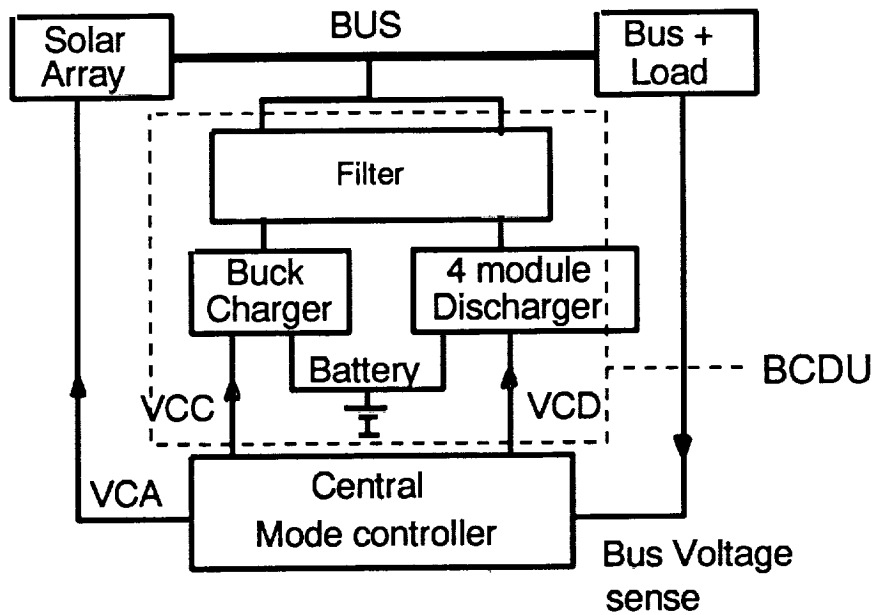

- New models are controlled by a central mode controller
- New discharger is a 4-module boost converter
- Models are set up as per the proposed hardware design
- Details are shown in the subsequent simulations
- Each mode is tested with a step load change
- Mode transition is induced by changing the illumination level

SOLAR ARRAY SWITCHING UNIT OPERATION

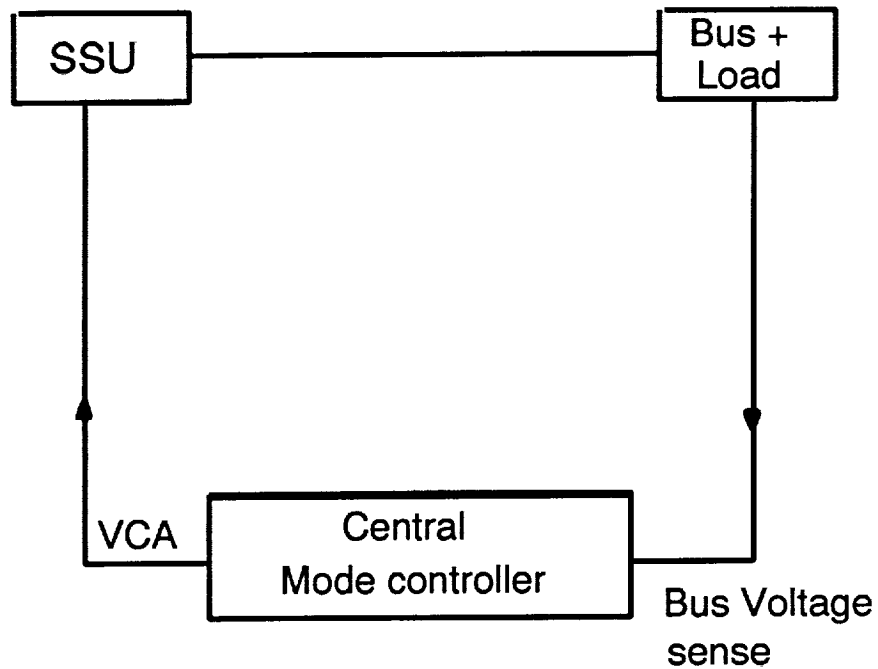

- The solar array is controlled by a central mode controller
- The bus is regulated by the array
- The simulation shows a change in parallel strings with load

SOLAR ARRAY OPERATION FOR LOAD STEP CHANGE

0 0.4 0.8 1.2 1.6 2.0 2.4 m sec

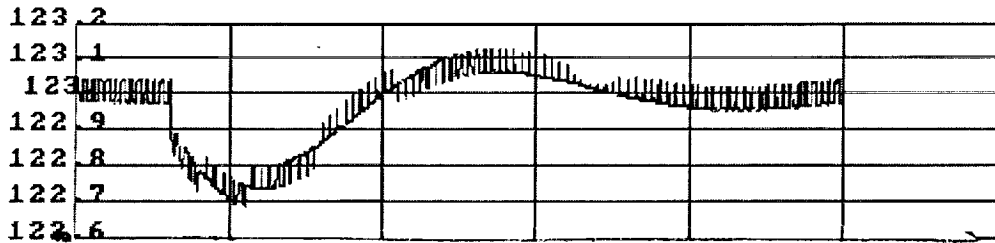

Bus
Voltage

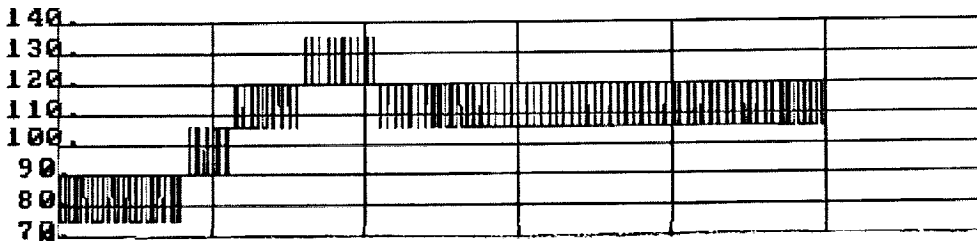

Number of
parallel
strings

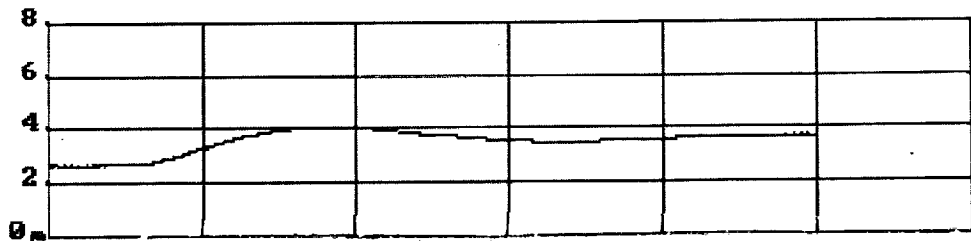

Control
voltage

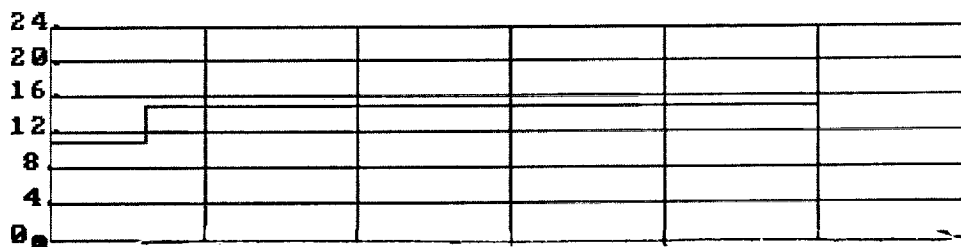

Load
current

DISCHARGER MODEL TEST SIMULATION

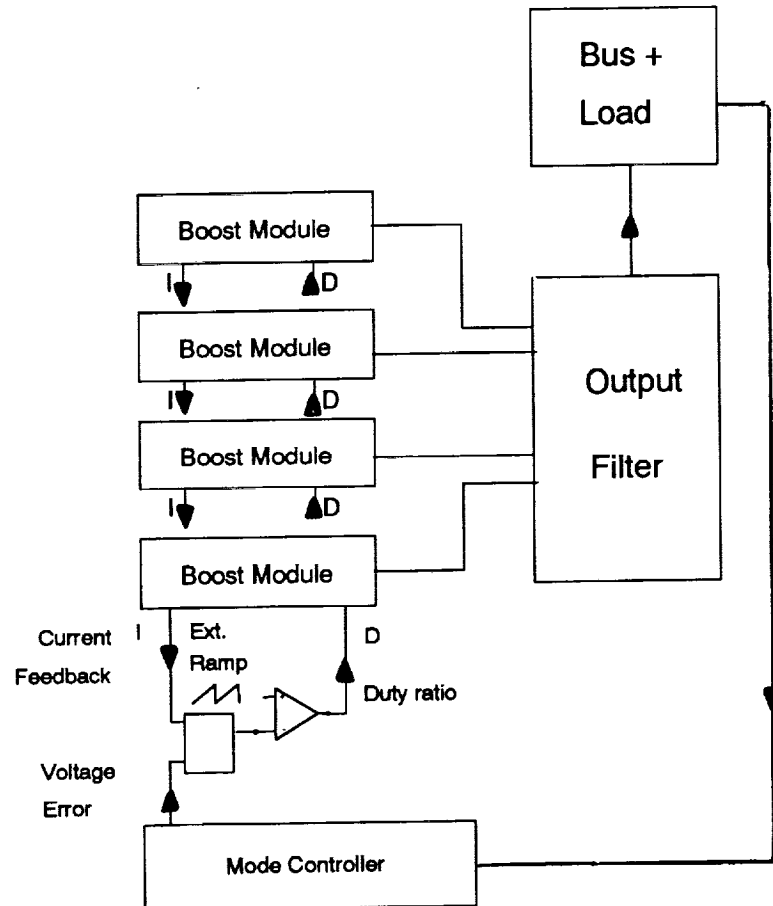

- The voltage error is common to all modules
- Each module has its own phase shifted PW modulator
- Current feedback is applied separately to each module

PHASE-SHIFTED RAMPS FOR MULTIMODULE BOOST DISCHARGER

0 20 40 60 80 μ sec

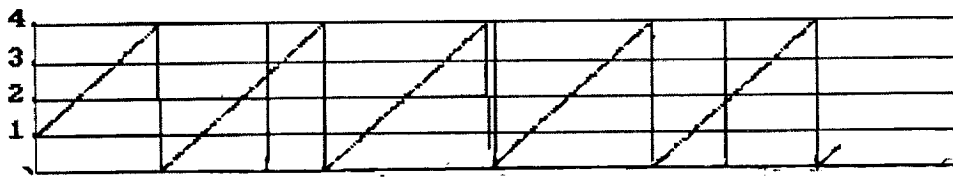
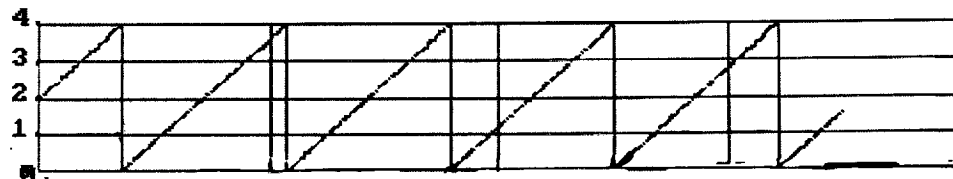
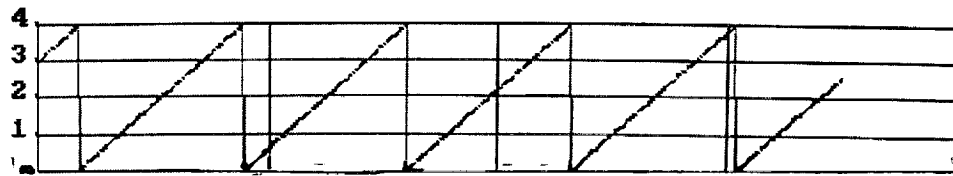
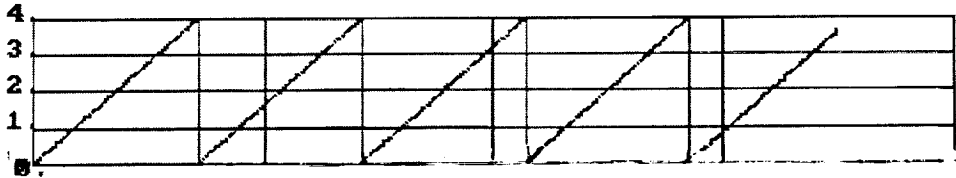

DISCHARGER OPERATION FOR A LOAD STEP CHANGE

0.4 0.6 0.8 1.0 1.2 1.4 1.6 m sec

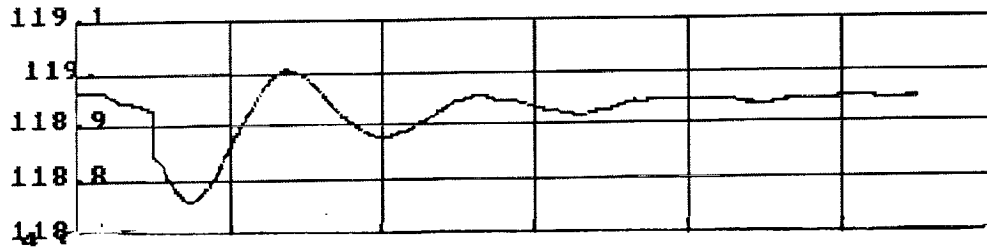

Bus Voltage

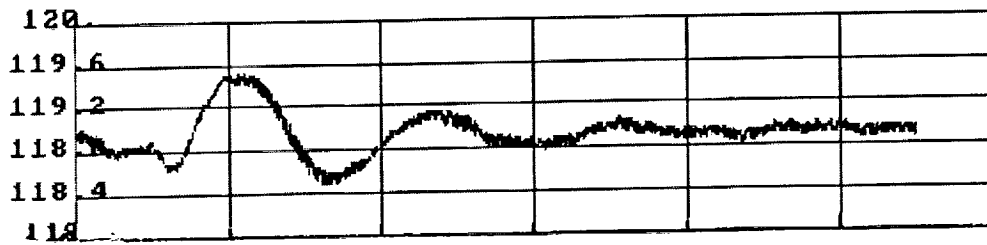

Filter primary cap. volt.

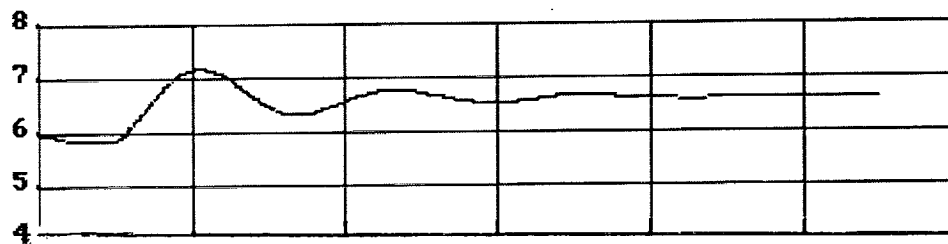

Control voltage

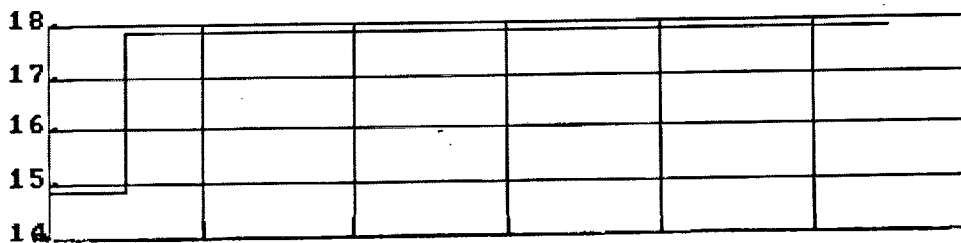

Load current

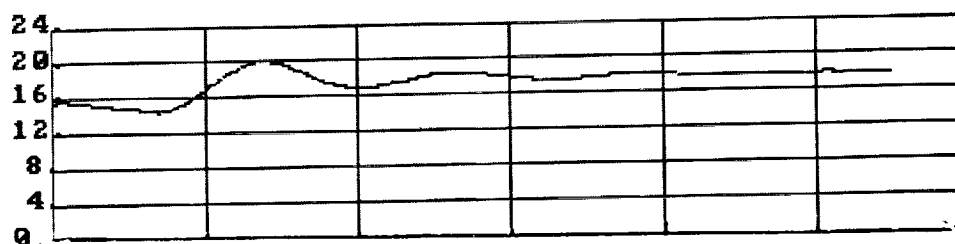

Filter Inductor Current

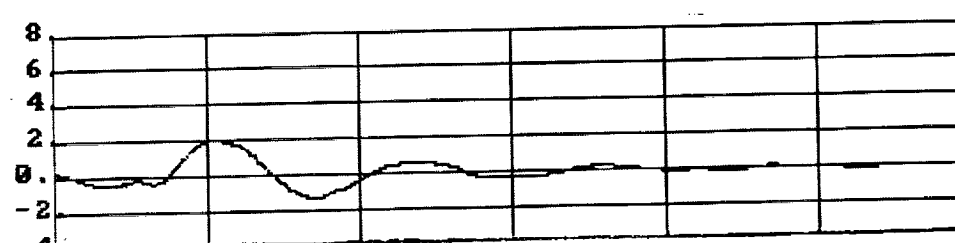

Damping Inductor Current

EQUAL SHARING OF CURRENT BY THE FOUR MODULES

0.4 0.6 0.8 1.0 1.2 1.4 1.6 m sec

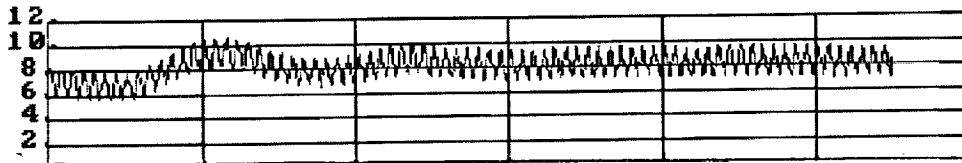
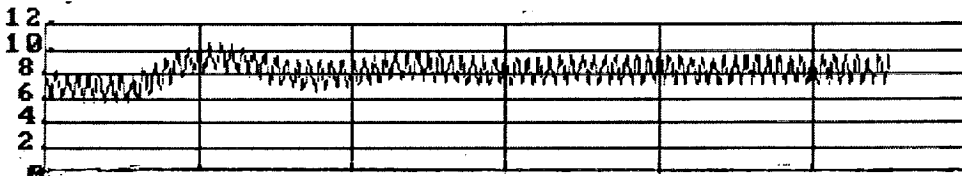
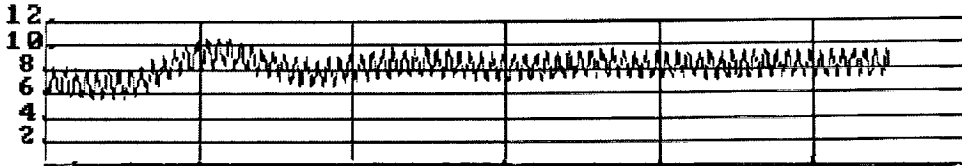
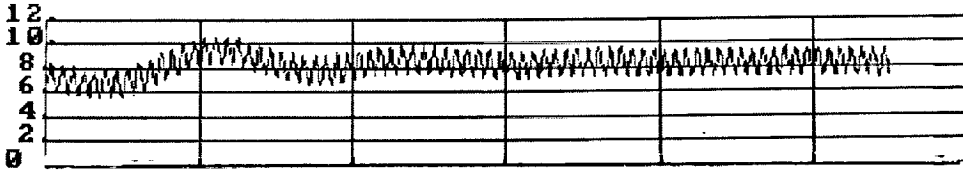

DISCHARGER OPERATION WITHOUT PHASE SHIFTED RAMPS

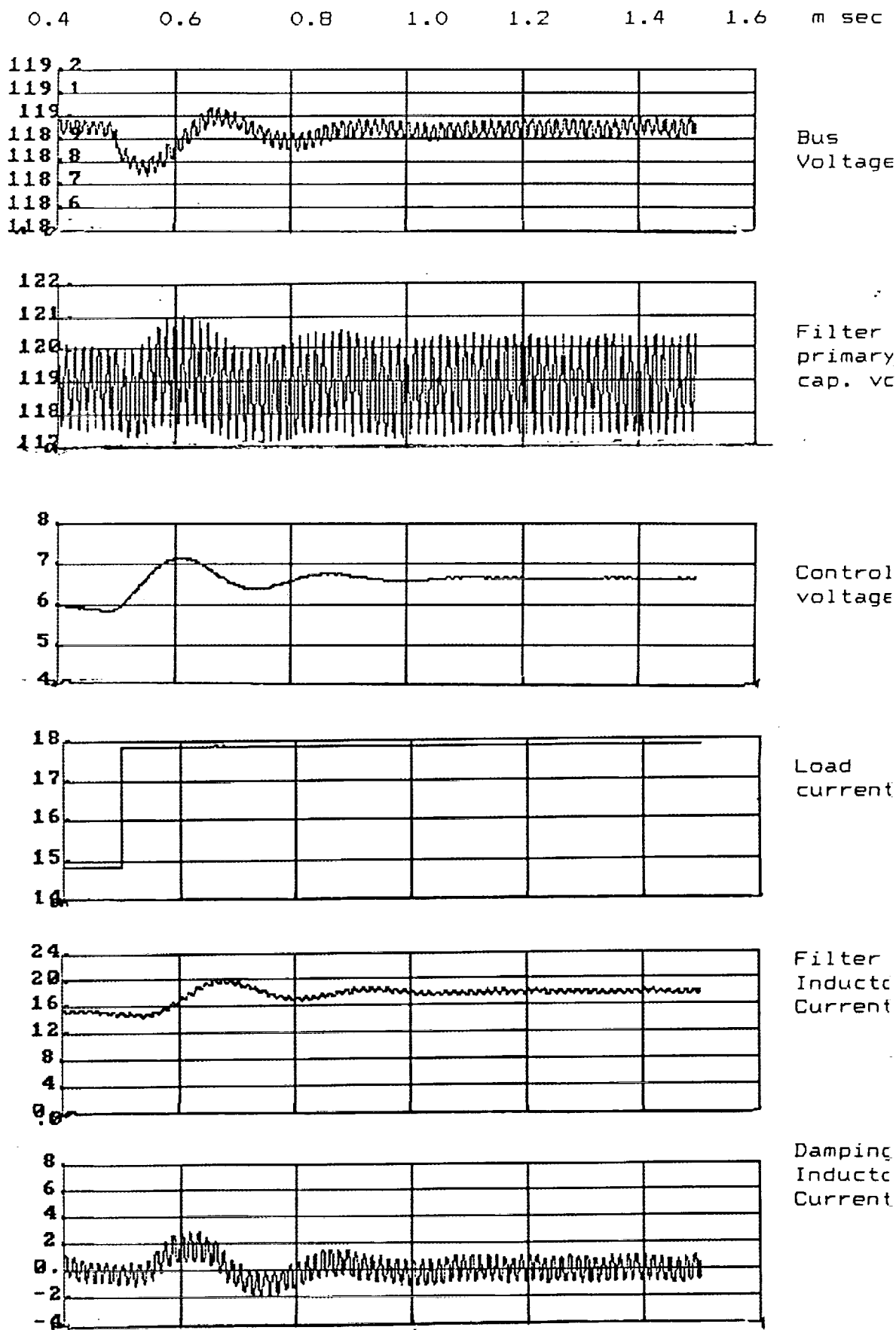

ORIGINAL PAGE IS
OF POOR QUALITY

CHARGER MODEL TEST SIMULATION 1

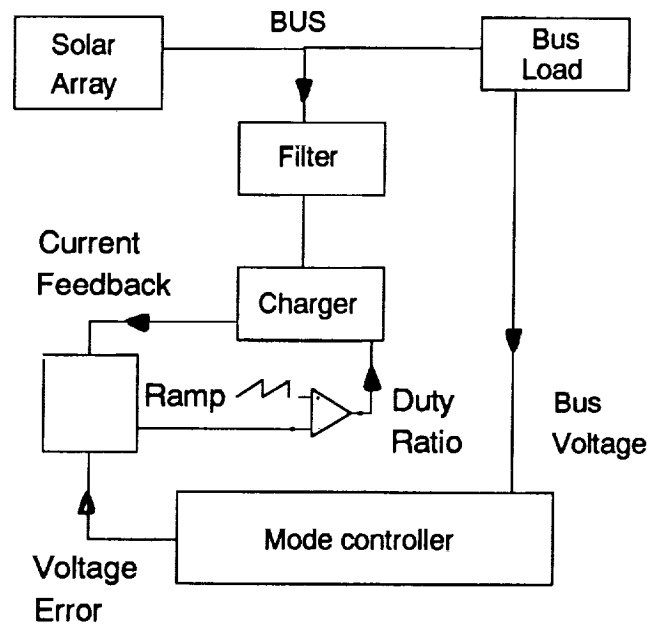

- In the voltage regulation mode, the charger regulates the bus
- The bus is regulated by changing the charging current

CHARGER MODEL TEST SIMULATION 2

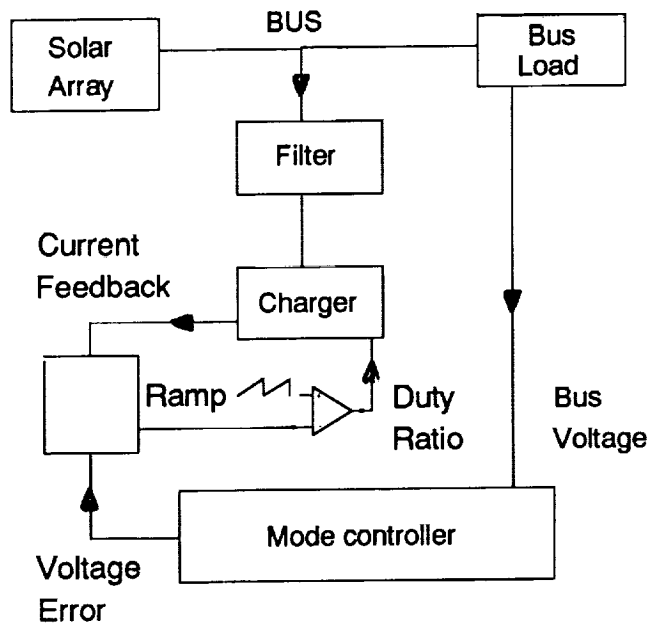

- In the current regulation mode, the array regulates the bus
- The charger regulates the charging current at the limiting value

CHARGER IN CURRENT REGULATION MODE

0 0.1 0.2 0.3 0.4 0.5 0.6 m sec

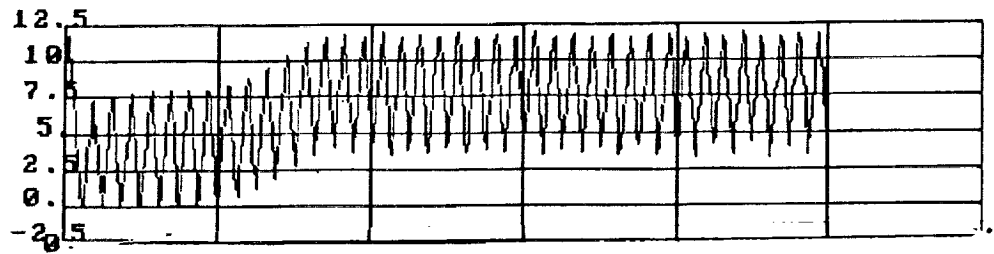

Battery charging current

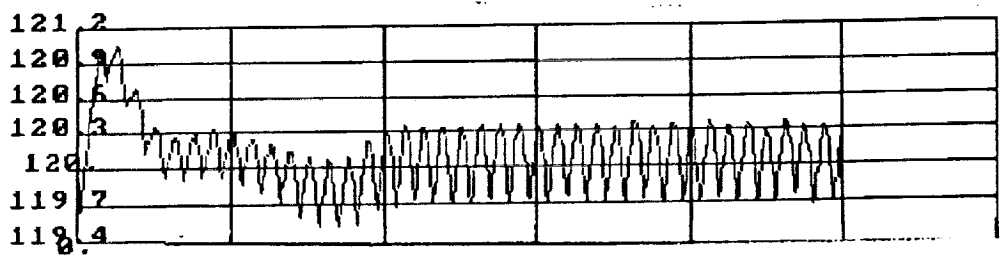

Filter Cap. voltage

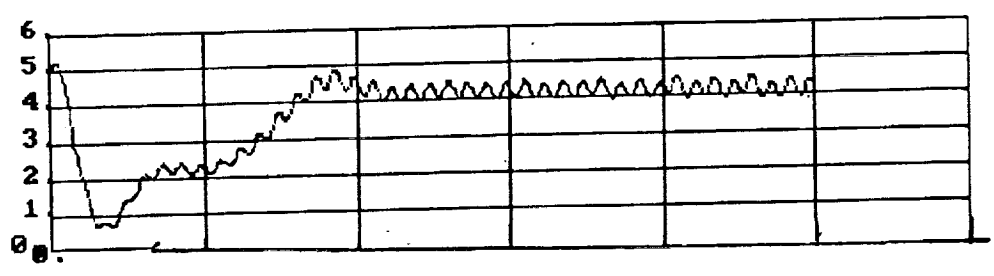

Charger Input current

1.2 - 20 A
C-2

CHARGER IN VOLTAGE REGULATION MODE

0 0.1 0.2 0.3 0.4 0.5 0.6 m sec

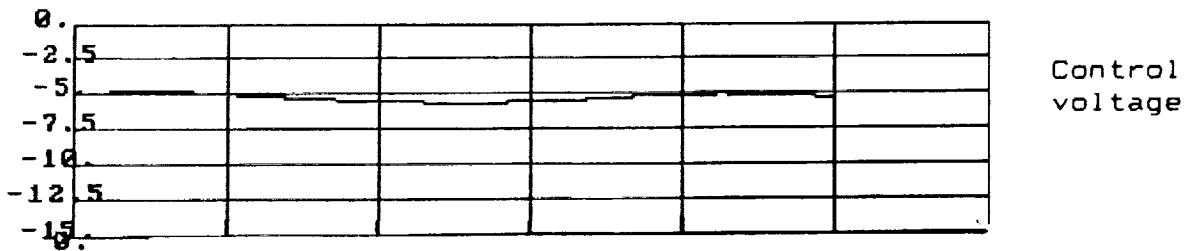
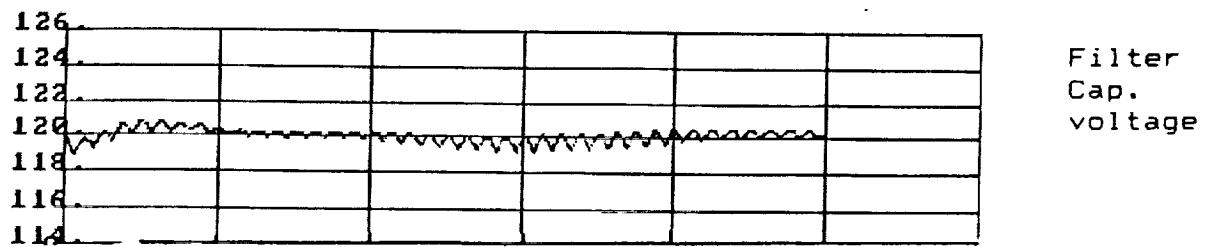
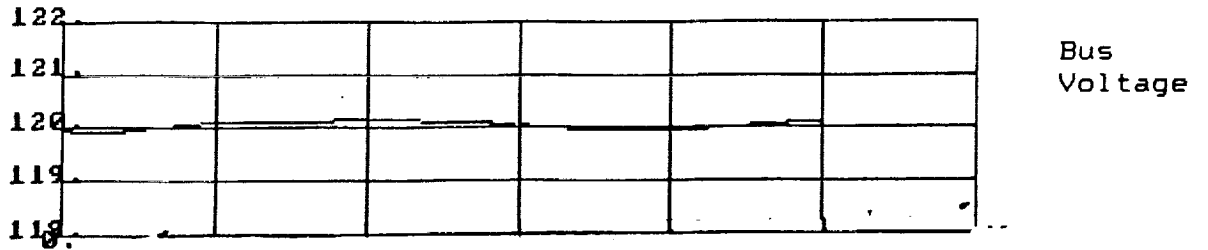

MODE TRANSITION SIMULATION

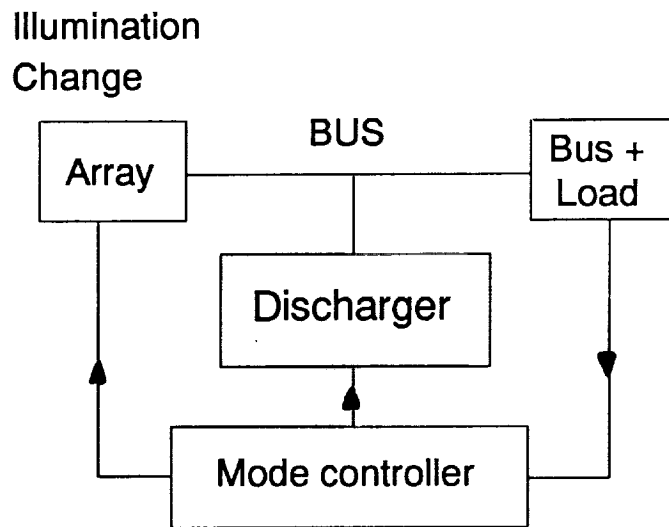

- Mode transitions are induced by changing the illumination level
- With sufficient illumination, the array regulates the bus
- At low illumination level, the discharger regulates the bus

SIMULATION FOR TRANSITION FROM SUNLIGHT TO ECLIPSE

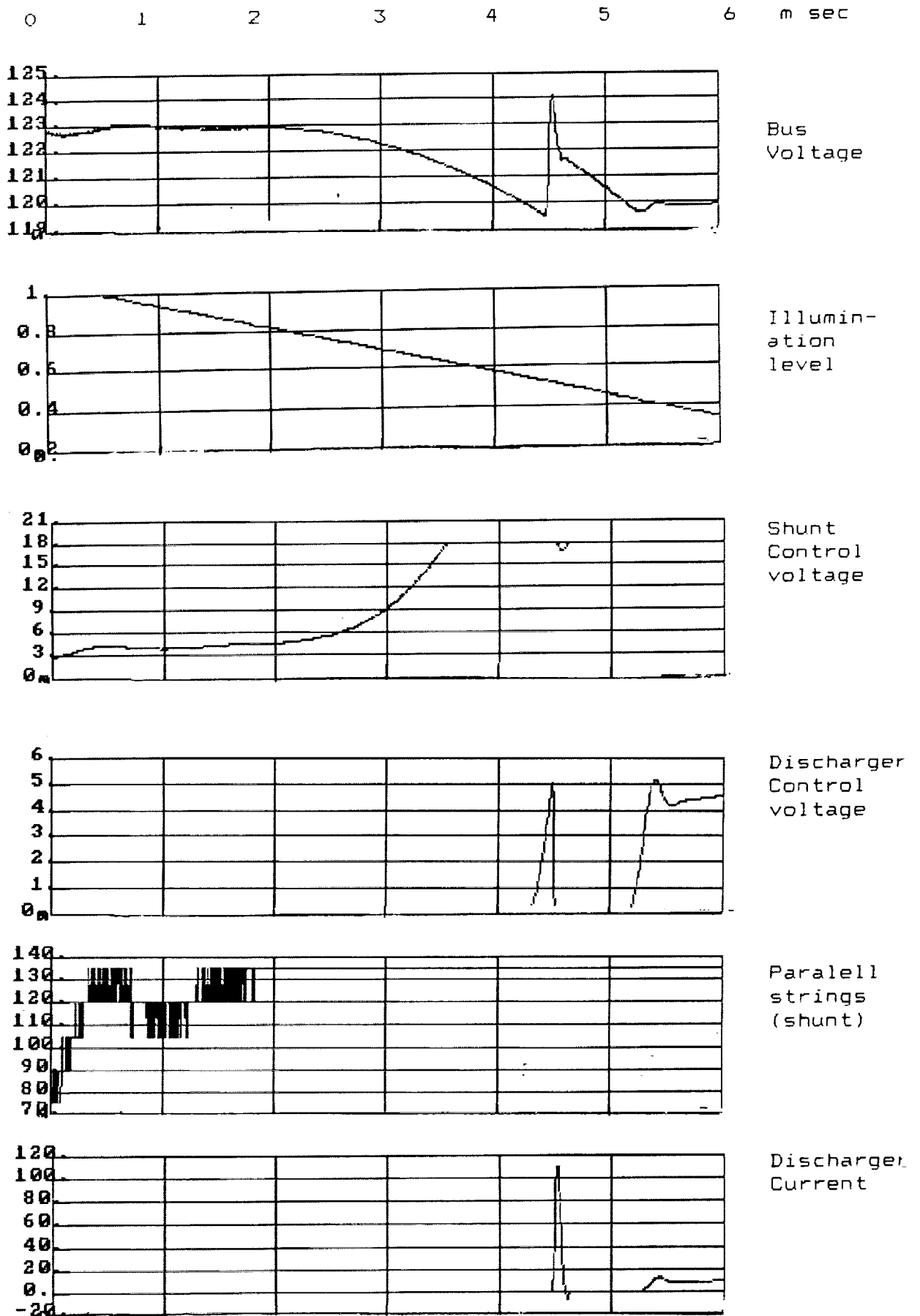

2. SPACE PLATFORM

POWER SYSTEM TEST BED

NASA/GSFC Space Platform Testbed

Year 1 Tasks

- | | |
|--|-------|
| 1. Design Multi-Module Boost Converter | DS |
| 2. Design VFPPAT Converter | DS |
| 3. Build Multi-Module Boost Converter | DS |
| 4. Build VFPPAT Converter | SD |
| 5. Design Battery Charger | TS |
| 6. Build Battery Charger | TS |
| 7. Test Multi-Module Boost Converter (Open-Loop) | DS/JI |
| 8. Test VFPPAT Converter | SD |
| 9. Select Optimum Discharger & Design Control Loop | DS/SI |
| 10. Build Discharger Controller, Integrate & Test | DS/SI |
| 11. Test Battery Charger | TS |
| 12. Design Charger Controller | TS |
| 13. Build Charger Controller & Integrate | TS |
| 14. Integrate Charger & Discharger (W/Mode Controller) | DS |
| 15. Test ORU System | DS |
| 16. Investigate Bi-directional Converter | |

Space Platform Testbed Schedule

△	PLAN
▤	CHANGE
▲	COMPLETE

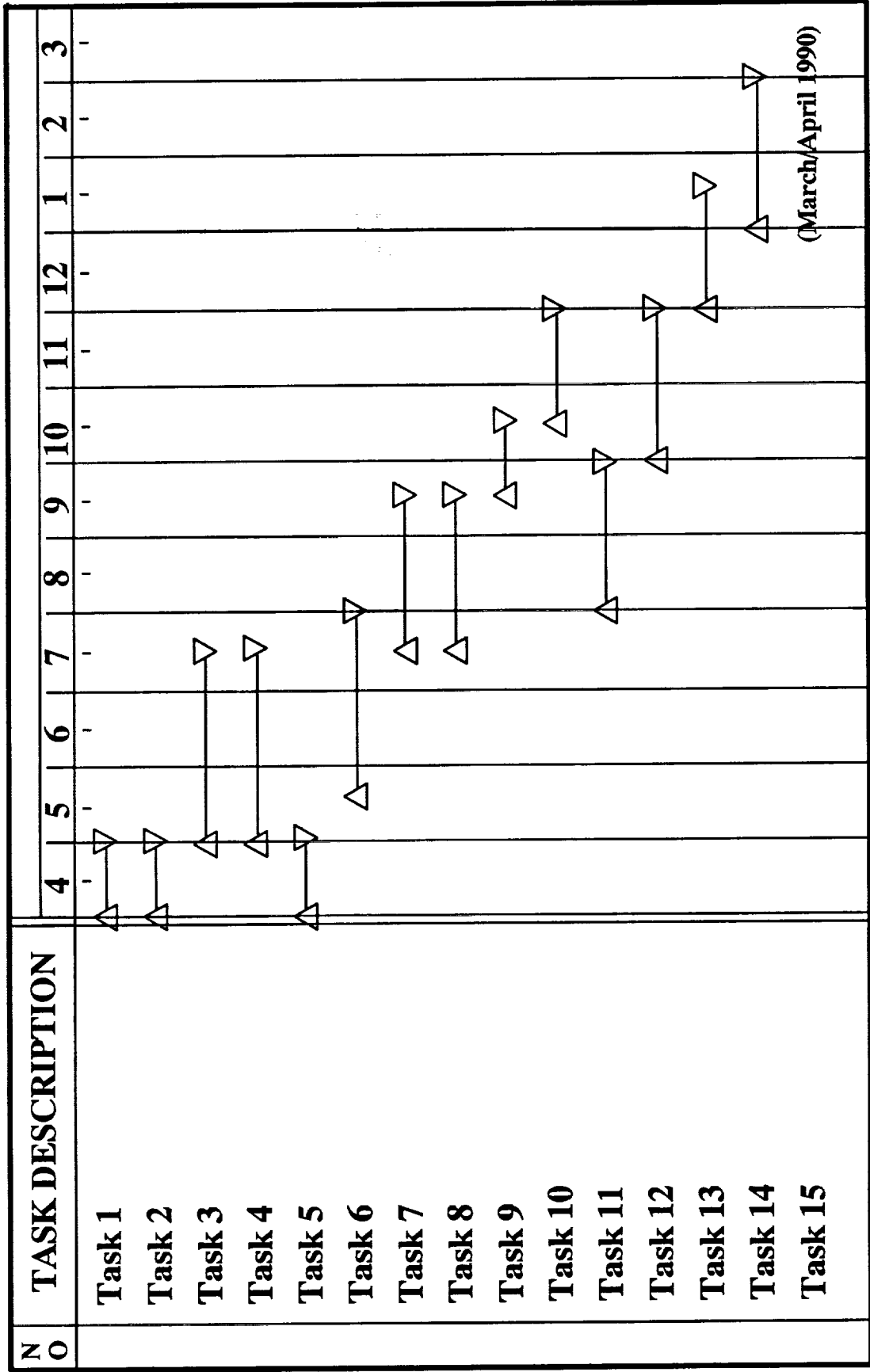

97% EFFICIENT FOUR MODULE BOOST DESIGN

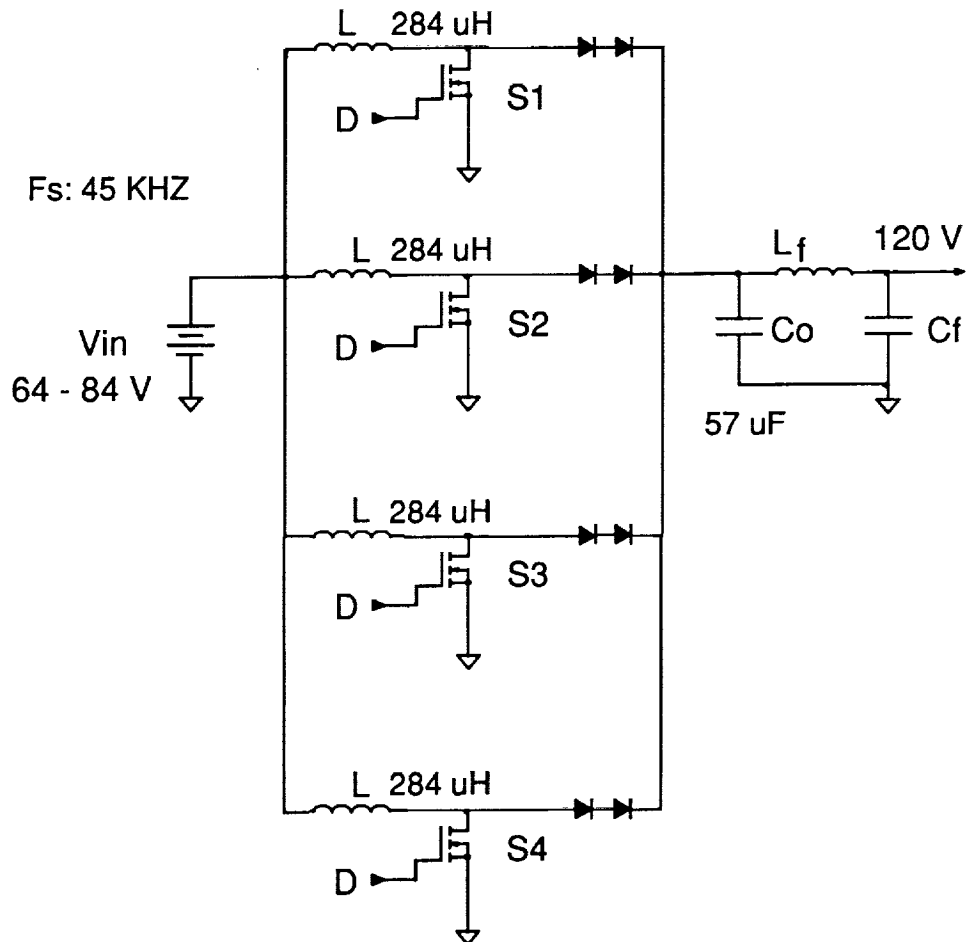

INDUCTOR DESIGN

INDUCTOR TURNS: 31
 INDUCTOR CORE WIDTH: 8.6E-3 M
 INDUCTOR WINDOW WIDTH: 8.9E-3 M
 INDUCTOR AIR GAP: 9 MILS
 INDUCTOR WIRE SIZE: 1.54E-6 M²

LOSS BREAKDOWN

FET CONDUCTION LOSS: 9.1 W
 FET SWITCHING LOSSES: 11.8 W
 DIODE CONDUCTION LOSS: 22.5 W
 DIODE SWITCHING LOSSES: 3.7 W
 INDUCTOR COPPER LOSS: 5.9 W
 INDUCTOR CORE LOSS: 4.8 W

WEIGHT BREAKDOWN

INDUCTOR WEIGHT: 0.16 KG
 CAPACITOR WEIGHT: 0.16 KG
 TOTAL: 0.32 KG

MULTI-MODULE BOOST HARDWARE DEVELOPMENT

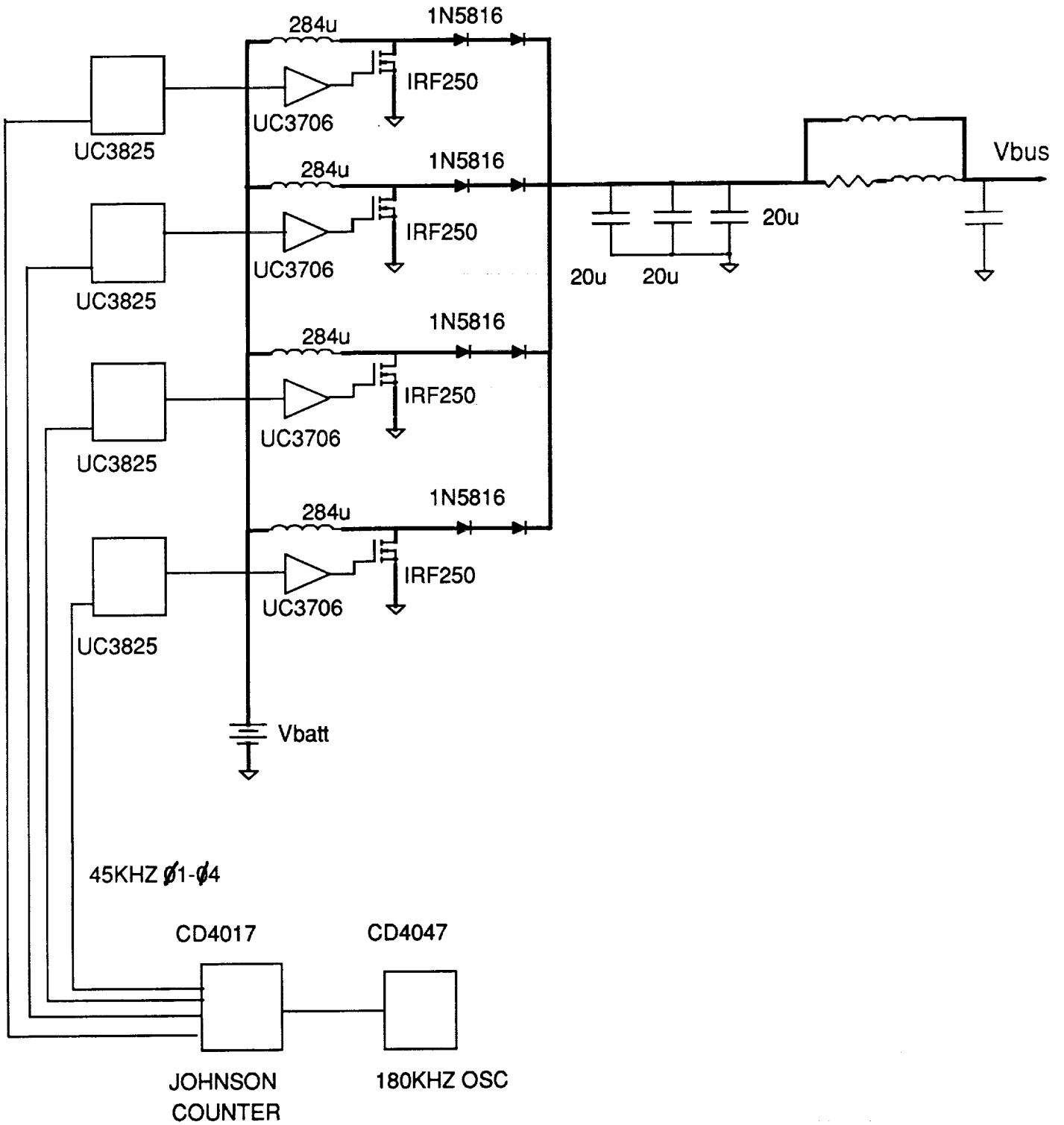

FOUR MODULE BOOST INDUCTOR

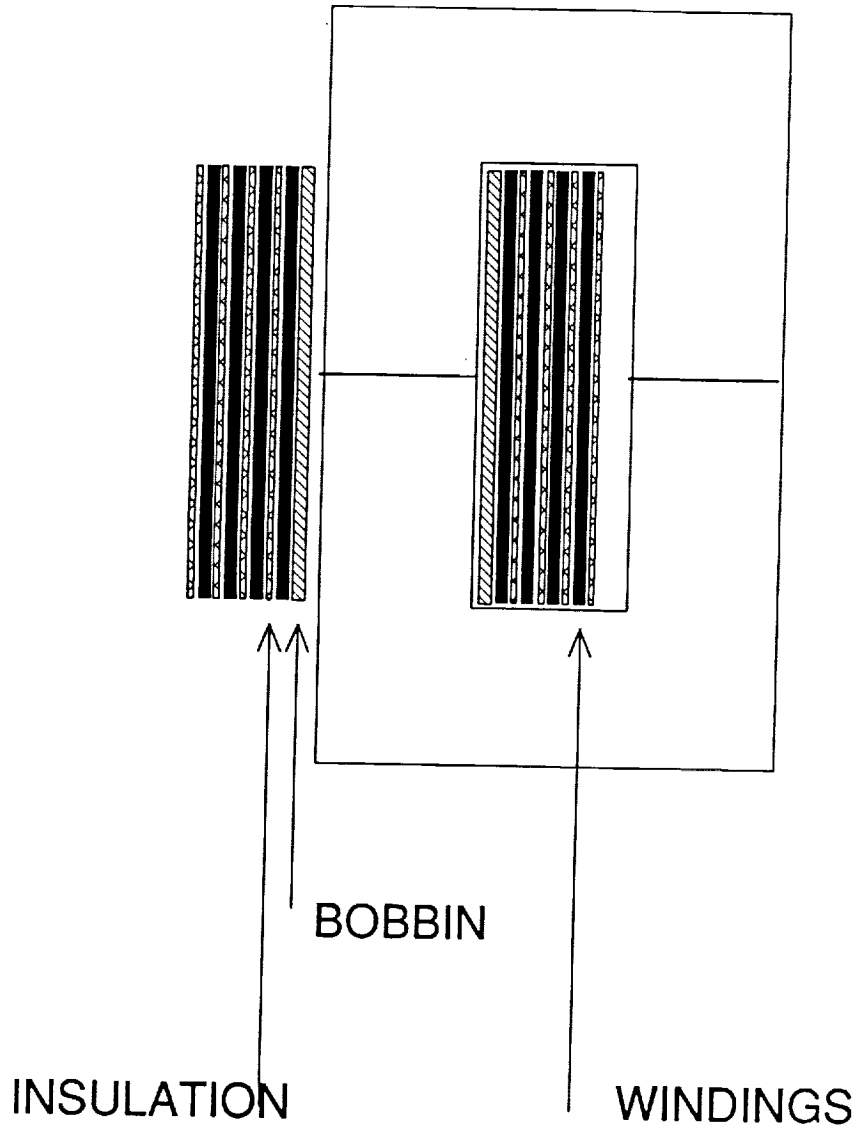

CORE: MC1200-1B (METGLAS)
40 TURNS 4 MIL X 1 INCH COPPER FOIL
13 MIL AIRGAP

FOUR MODULE BOOST CONVERTER BATTERY DISCHARGER STRESS ANALYSIS

<u>COMPONENT PARAMETER</u>	<u>APPLIED VALUE</u>	<u>RATED VALUE</u>	<u>STRESS RATIO</u>
MOSFET CONTINUOUS DRAIN CURRENT	9 AmpS	33 Amps	27%
PEAK TRANSISTOR DRAIN-TO-SOURCE VOLTAGE	120 Volts	200 Volts	62%
PEAK TRANSISTOR GATE VOLTAGE	10 Volts	±20 Volts	50%
PEAK DIODE CURRENT	9 AmpS	20 Amps	45%
PEAK DIODE REVERSE VOLTAGE	60 Volts	150 Volts	40%
OUTPUT CAPACITOR VOLTAGE	120 Volts	200 Volts	60%
OUTPUT CAPACITOR RMS CURRENT	1.1 Amps	22 Amps	5%

VOLTAGE-FED, PUSH-PULL, AUTOTRANSFORMER, (VFPPAT) BATTERY DISCHARGER

HARDWARE DESIGN TOPIC LIST

	<u>PAGE</u>
DESIGN SPECIFICATIONS	2.1.2.2
BASIC SCHEMATIC AND RESULTING WAVEFORMS	2.1.2.3
SCHEMATIC WITH ACTUAL COMPONENTS	2.1.2.4
PRELIMINARY PARTS LIST	2.1.2.5
COMPONENT STRESS EVALUATION	2.1.2.6
AUTOTRANSFORMER DESIGN	2.1.2.7
INDUCTOR DESIGN	2.1.2.8

VFPPAT

BATTERY DISCHARGER DESIGN SPECIFICATIONS

<u>PARAMETER</u>	<u>SPECIFICATION</u>
INPUT VOLTAGE RANGE	64 VDC to 84 VDC
OUTPUT VOLTAGE RANGE	120 VDC \pm 4%
OUTPUT VOLTAGE RIPPLE	200 mV peak to peak
OUTPUT POWER RANGE	0 Watts to 1800 Watts
SWITCHING FREQUENCY	40 kHz
EFFICIENCY GOAL	96%
TRANSIENT PERFORMANCE	
OUTPUT VOLTAGE PEAKING RANGE	115.2 VDC - 124.8 VDC
OUTPUT SETTling TIME	10 msec

VOLTAGE-FED, PUSH-PULL WITH TAPPED AUTOTRANSFORMER (VFPPAT) CONVERTER

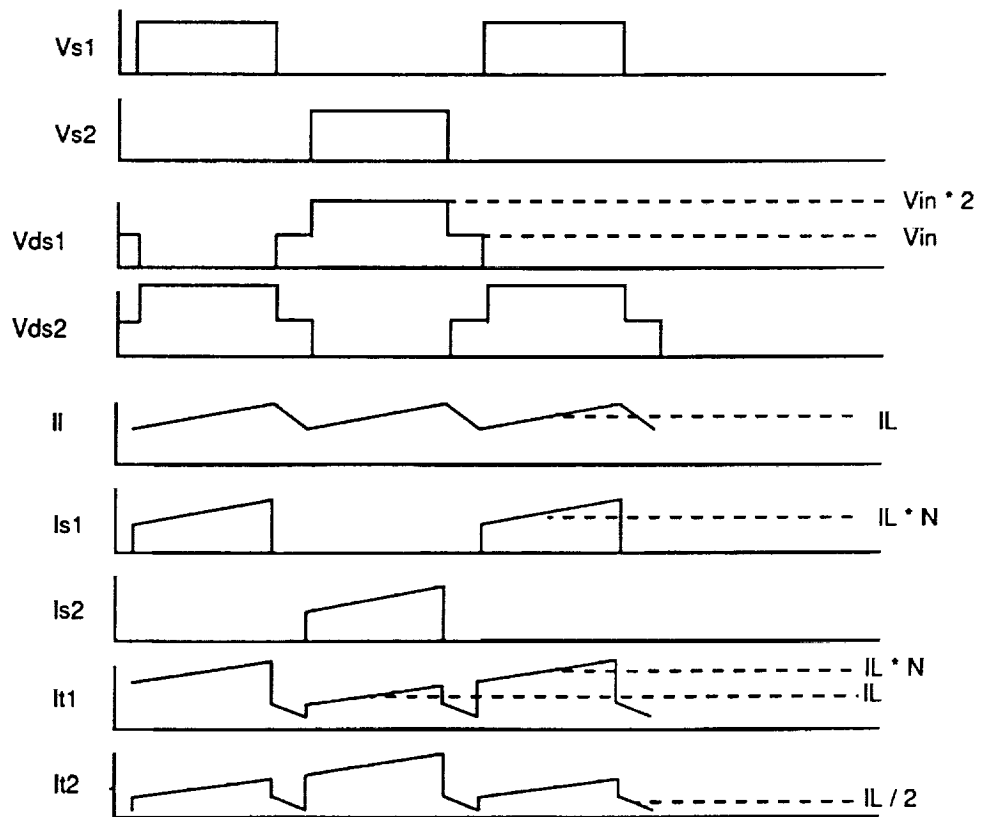
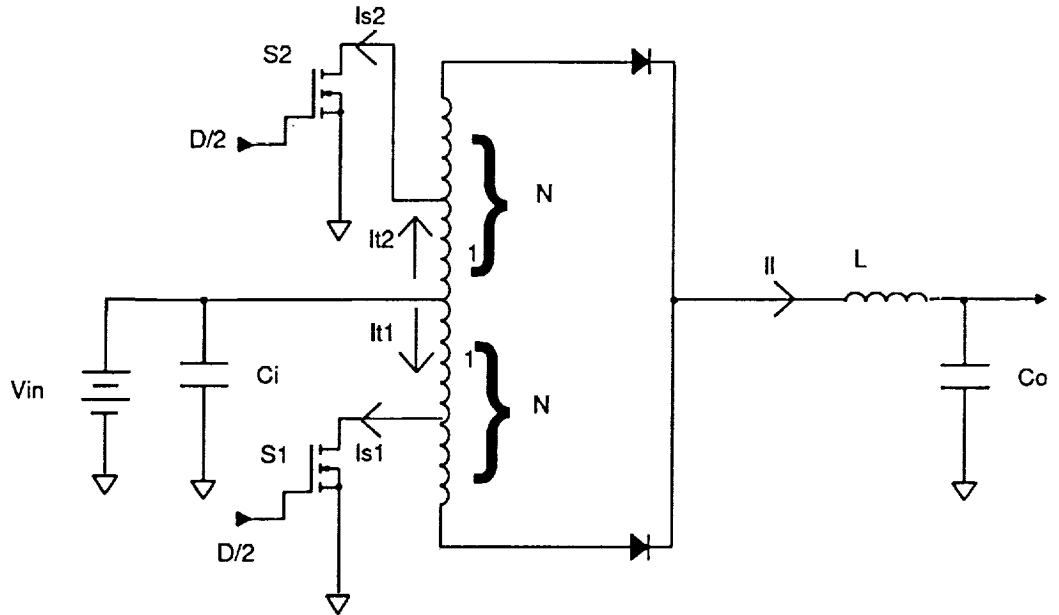

VFPPAT SCHEMATIC WITH ACTUAL COMPONENTS

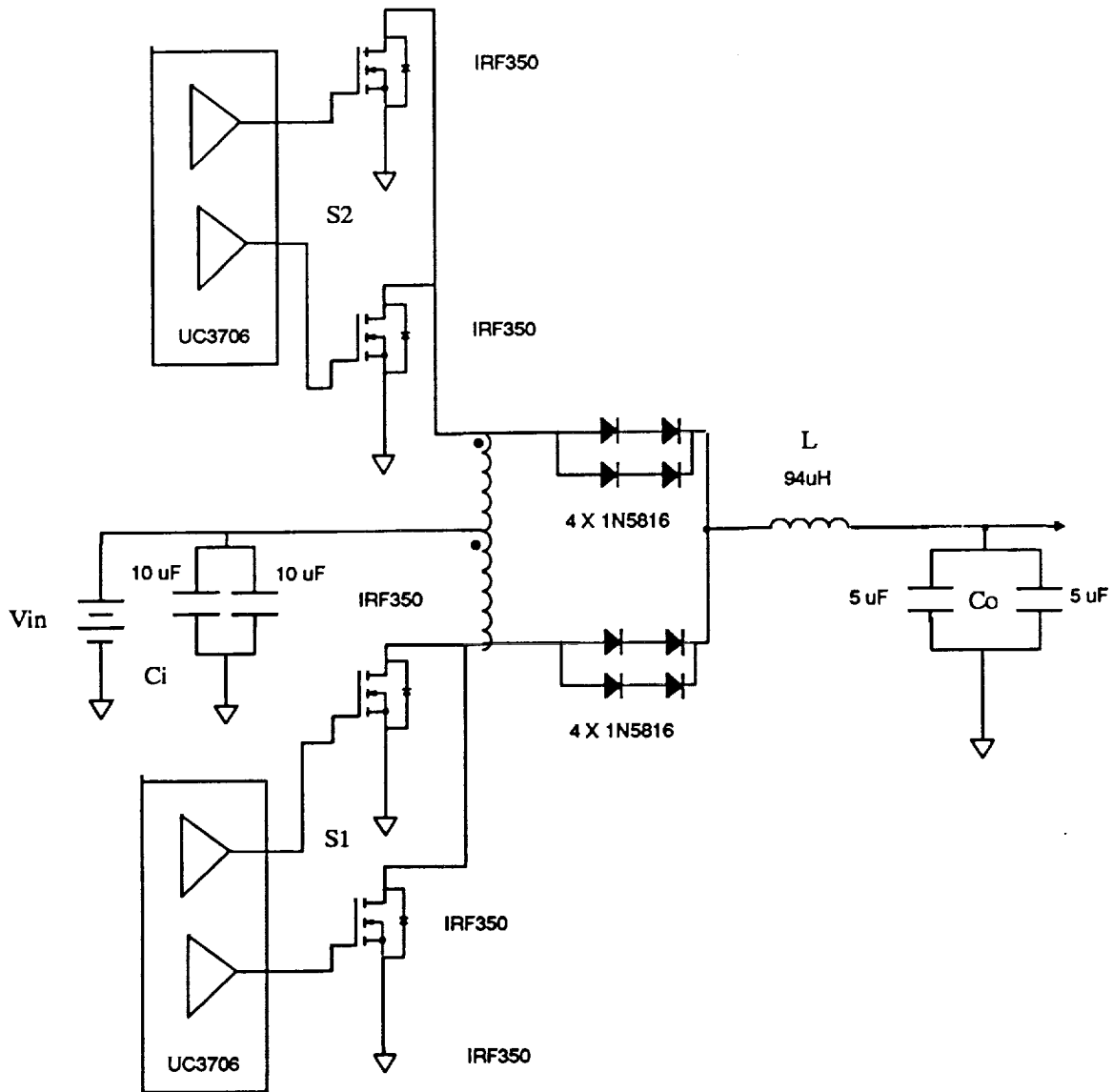

DISCHARGER POWER STAGE COMPONENTS

POWER SWITCH

- IRF350, INTERNATIONAL RECTIFIER
- TWO IN PARALLEL FOR HIGH EFFICIENCY
- $R_{dson} = 250 \text{ m}\Omega$

POWER DIODE

- 1N5816, UNITRODE
- $T_{rr} = 35 \text{ nS}$

INDUCTOR

- MC0007 METGLAS CUT C-CORE, MAGNETICS, INC.
- $L = 94 \text{ }\mu\text{H}$

INPUT AND OUTPUT CAPACITORS

- POLYPROPYLENE, ELECTRONIC CONCEPTS, INC.
- LOW ESR
- LIGHTWEIGHT

DRIVER IC

- UC3706, DUAL OUTPUT DRIVER, UNITRODE
- PEAK OUTPUT CURRENT = 1.5 A

VFPPAT MAXIMUM COMPONENT STRESS EVALUATION

<u>STRESS PARAMETER</u>	<u>** APPLIED VALUE</u>	<u>RATED VALUE</u>	<u>PERCENT USAGE</u>
PEAK TRANSISTOR DRAIN CURRENT*	8.3 Amps	60 Amps	14%
PEAK TRANSISTOR DRAIN-TO-SOURCE VOLTAGE	168 Volts	400 Volts	42%
PEAK TRANSISTOR GATE VOLTAGE	10 Volts	±20 Volts	50%
PEAK DIODE CURRENT*	8.15 Amps	20 Amps	41%
PEAK DIODE REVERSE VOLTAGE*	82 Volts	150 Volts	55%
OUTPUT CAPACITOR VOLTAGE	120 Volts	200 Volts	60%
OUTPUT RMS CURRENT*	0.4 Amps	22.5 Amps	2%
INPUT CAPACITOR VOLTAGE	84 Volts	200 Volts	42%
INPUT CAPACITOR RMS CURRENT*	3.25 Amps	15 Amps	25%

* 50% DIVISION OF PARAMETER ASSUMED

** APPLIED VALUES PREDICTED USING A SPREAD SHEET PROGRAM

AUTOTRANSFORMER DESIGN

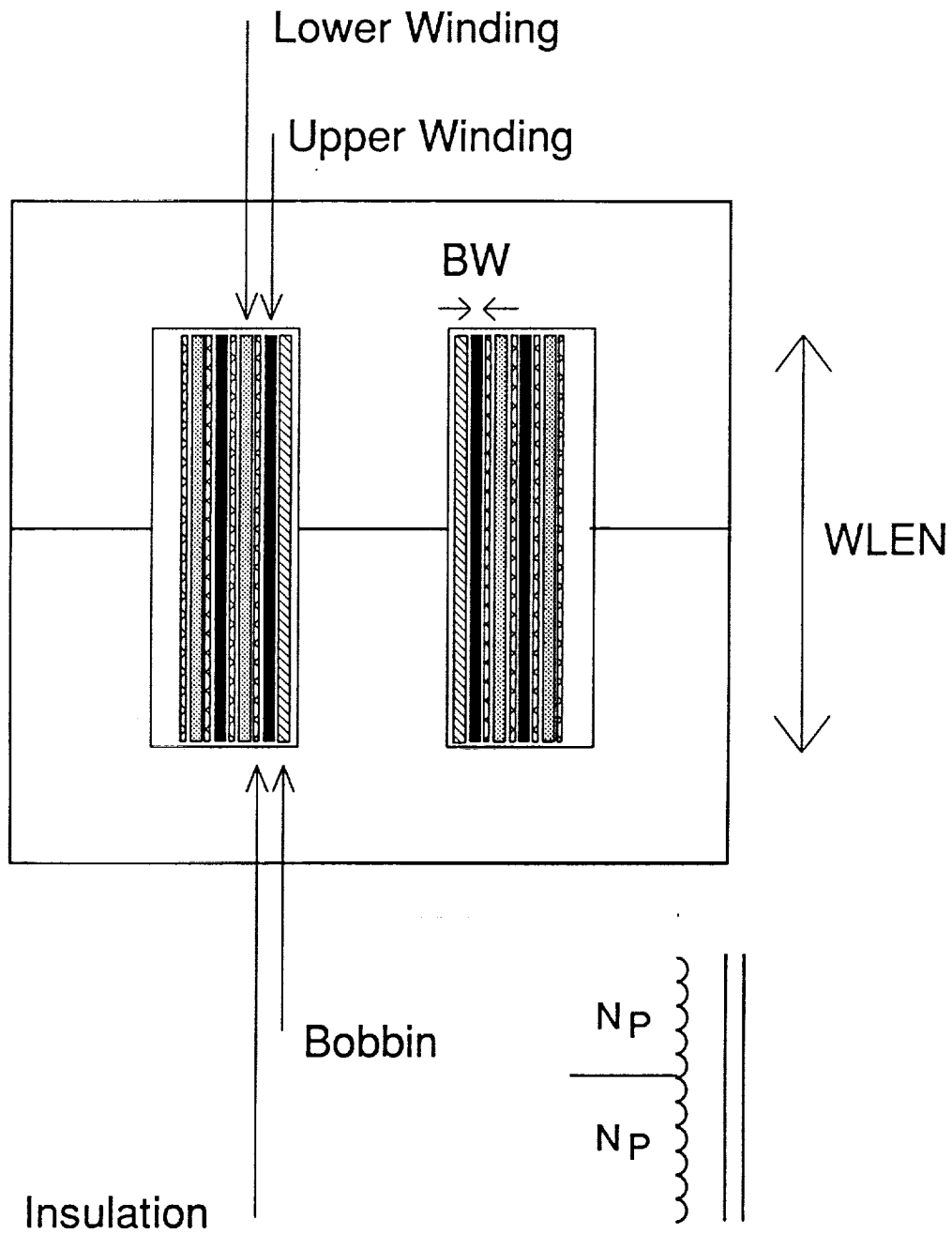

CORE: EE4242/15 TDK H7C1
20 TURNS 3 MIL X 1.1 INCH COPPER FOIL

VFPPAT INDUCTOR DESIGN

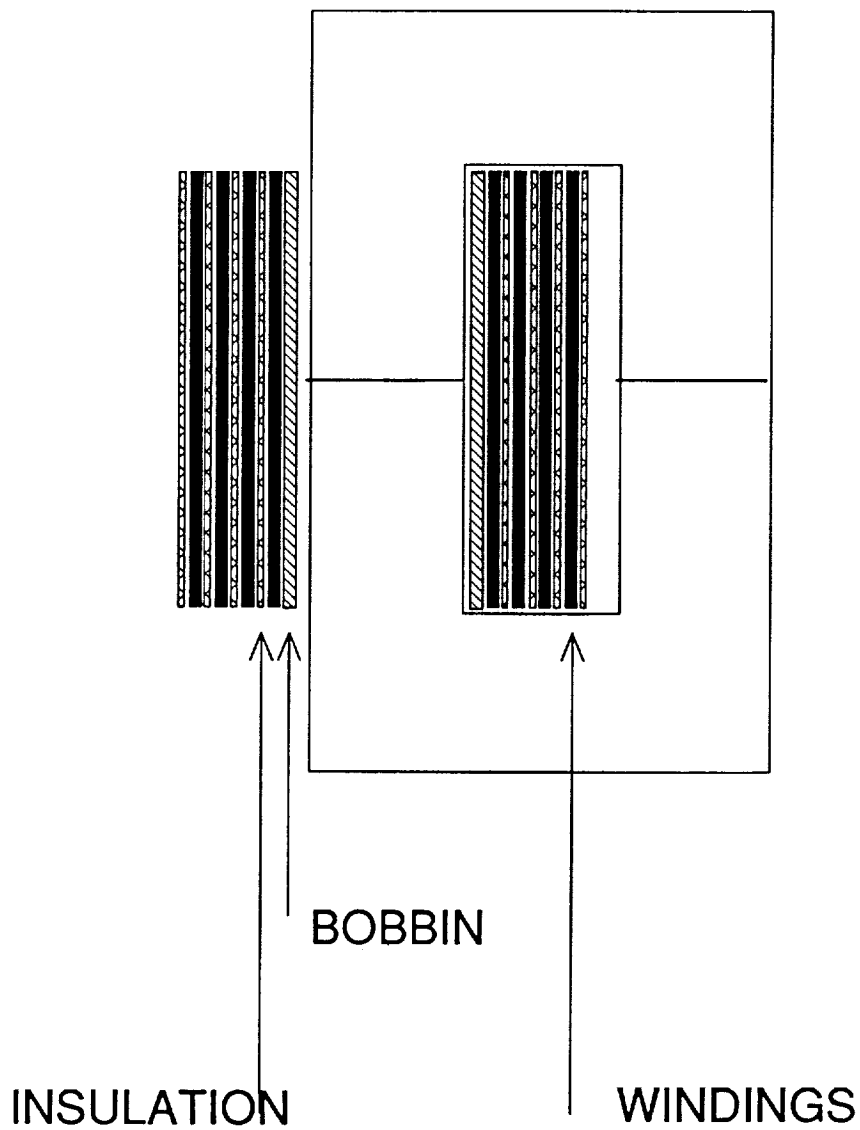

CORE: MC0007-1B (METGLAS)
32 TURNS 4 MIL X 1 INCH COPPER FOIL
24 MIL AIRGAP

2.1.2.8

BATTERY CHARGER DESIGN SPECIFICATIONS

<u>PARAMETER</u>	<u>SPECIFICATION</u>
INPUT VOLTAGE RANGE	120 VOLTS +/- 4%
OUTPUT VOLTAGE RANGE	53 - 84 VOLTS
DUTY RATIO	44% TO 70%
TOPOLOGY	SINGLE PHASE BUCK
CHARGE CURRENT RANGE	1 TO 20 AMPS
SWITCHING FREQUENCY	80 KHz
ESTIMATED EFFICIENCY	95 %
CONTROL	BUS VOLTAGE / CHARGE CURRENT

BATTERY CHARGER SCHEMATIC

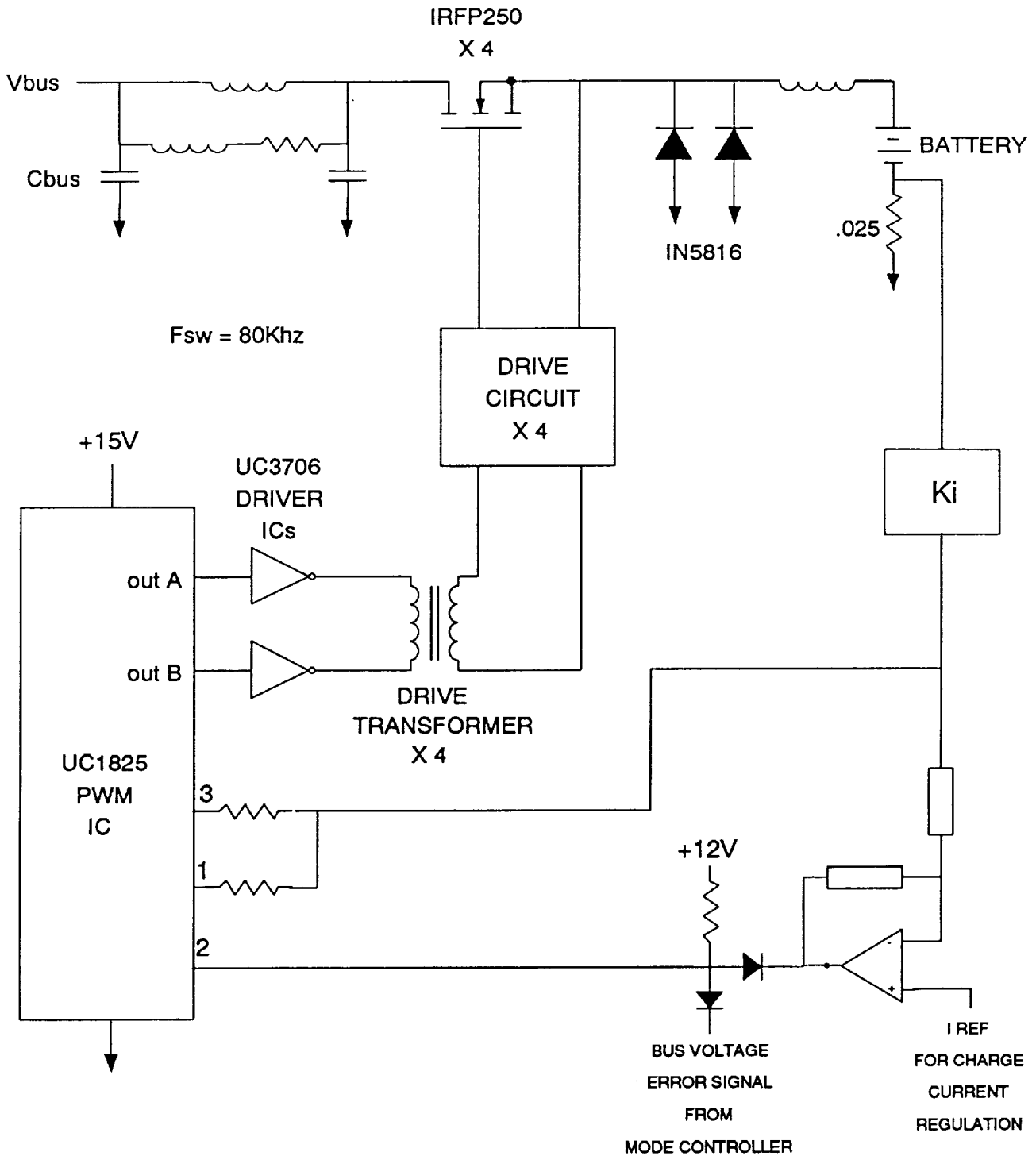

CHARGER POWER STAGE COMPONENTS

POWER SWITCH

- IRFP250 MOSFET, INTERNATIONAL RECTIFIER
- FOUR IN PARALLEL FOR HIGH EFFICIENCY
- $R_{dson} = 85 \text{ m}\Omega$

POWER DIODE

- 1N5816, UNITRODE
- TWO IN PARALLEL
- $T_{rr} = 35 \text{ nS}$

INDUCTOR

- METGLAS CUT C-CORE, MAGNETICS, INC.
- $L = 46\mu\text{H}$

INPUT CAPACITOR

- POLYPROPYLENE, ELECTRONIC CONCEPTS, INC.
- LOW ESR
- LIGHTWEIGHT

INPUT FILTER

- COMMON TO DISCHARGER

BATTERY CHARGER STRESS ANALYSIS

<u>COMPONENT PARAMETER</u>	<u>APPLIED VALUE</u>	<u>RATED VALUE</u>	<u>STRESS RATIO</u>
MOSFET CONTINUOUS DRAIN CURRENT	5 Amps	33 Amps	15%
PEAK TRANSISTOR DRAIN-TO-SOURCE VOLTAGE	120 Volts	200 Volts	60%
PEAK TRANSISTOR GATE VOLTAGE	+10 Volts	±20 Volts	50%
RMS DIODE CURRENT	7.5 Amps	20 Amps	38%
PEAK DIODE REVERSE VOLTAGE	120 Volts	150 Volts	80%
INPUT CAPACITOR VOLTAGE	120 Volts	200 Volts	60%
INPUT CAPACITOR RMS CURRENT	4.2 Amps	15 Amps	28%

CHARGER POWER INDUCTOR DESIGN

MATERIAL : METGLAS

- HIGH B_{sat} ALLOWS SMALL INDUCTOR SIZE
- LOW LOSS
- 1 MIL LAMINATION : HIGH RESISTIVITY & LOW EDDY CURRENT LOSS
- HIGH PERMEABILITY
- LOW B_{sat} DRIFT OVER TEMPERATURE

CONDUCTOR AND INSULATION

- COPPER FOIL : 5 MIL THICKNESS
 - * HIGH WINDOW UTILIZATION
 - * LOW SKIN EFFECT LOSS
 - * LOW PROXIMITY LOSS
- INSULATION : 2 MIL KAPTON TAPE

CORE

- MAGNETICS, INC. MC1603 CUT C-CORE
- 14 MIL GAP FOR $L = 46 \mu\text{H}$
- DISADVANTAGE : GAP LOSS AND PROXIMITY LOSSES

DESIGN

- SPREAD SHEET PROGRAM
- AREA PRODUCT APPROACH
- TRADE-OFFS : LOSSES AND WEIGHT
- CONSIDERATIONS : STANDARD FOIL AND TAPE DIMENSIONS

CHARGER POWER INDUCTOR DESIGN

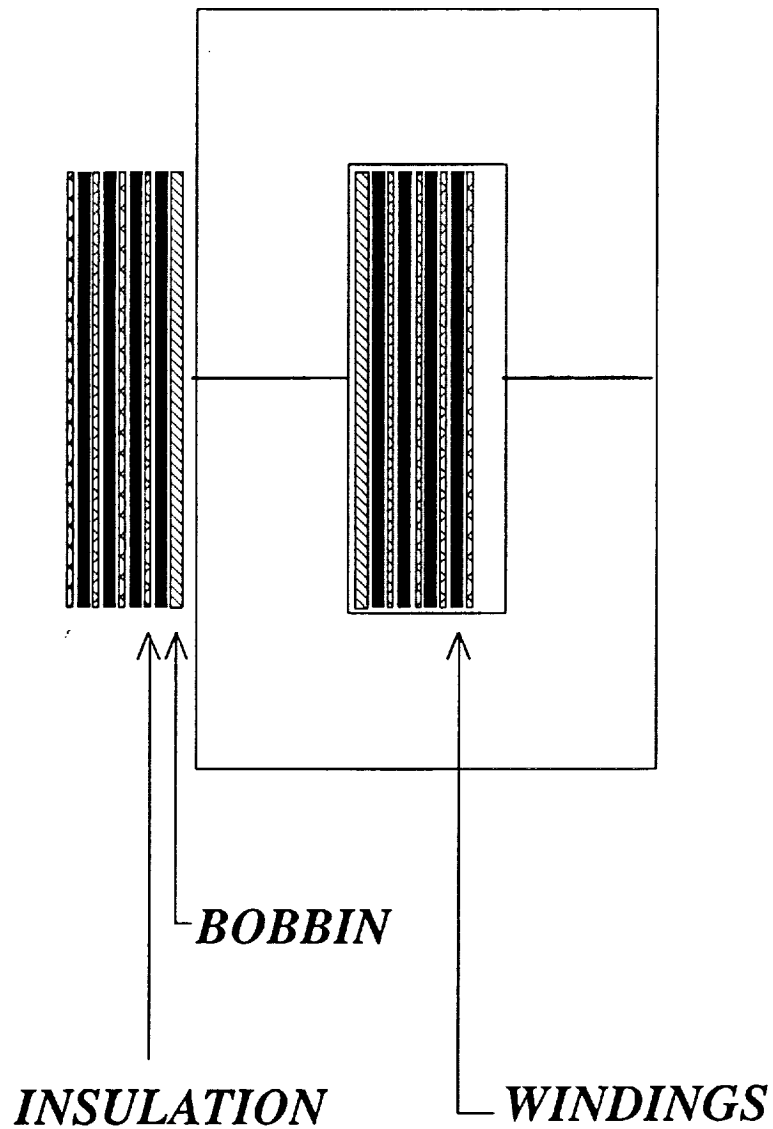

CORE : MC1603-1B (METGLAS)

21 TURNS COPPER FOIL (5 MIL X 1 INCH)

14 MIL AIR GAP (PER LEG)

CHARGER PWM AND DRIVE CIRCUITS

ISOLATED GATE DRIVE

DRIVE TRANSFORMER

- CORE RESET
- FERRITE TOROID
- 1:1 TURNS RATIO FOR HIGH COUPLING

FOUR SEPARATE DRIVE CIRCUITS

- MOSFET TURN-ON CURRENT SHARING
- ELIMINATING PARASITIC OSCILLATIONS

UNITRODE UC3706 DRIVER CHIPS

- $I_{peak} = 1.5$ AMPS
- SWITCHING SPEED

UNITRODE UC1825 PWM IC

CHARGER REGULATION CIRCUITS

CHARGE CURRENT REGULATION

- RESISTIVE CURRENT SENSING
 - * 25 mOHM IN SERIES WITH THE BATTERY
 - * ADVANTAGE : SIMPLICITY
 - * DISADVANTAGE : LOSSES
 - 10 A CHARGE = 2.5W LOSS
 - 20 A CHARGE = 10W LOSS
- ADJUSTABLE CHARGE CURRENT REFERENCE

BUS VOLTAGE REGULATION

- IMMEDIATELY AFTER ECLIPSE
- DURATION
- ERROR SIGNAL FROM MODE CONTROLLER (PCU)

CURRENT/VOLTAGE MODE SELECTION

- DIODE OR-ING CIRCUIT
- CHARGE CURRENT REFERENCE LEVEL
- MODE CONTROLLER THRESHOLDS

3. DISCUSSION

DISCUSSION

- 1) BATTERY CHARGING CURRENT
- 2) SOLAR ARRAY CHARACTERISTICS
- 3) BATTERY RIPPLE CURRENT SPEC
- 4) MINIMUM BATTERY VOLTAGE
- 5) BIDIRECTIONAL CONVERTER ??
- 6) APPROVED PARTS
- 7) SOLAR ARRAY SIMULATOR
- 8) MULTI-MODULE CHARGER ??
- 9) SERIES DIODES
- 10) V/T LIMIT

