

# N91-11967

## CODELESS GPS APPLICATIONS TO MULTI-PATH: CGAMP

P.F. MacDoran, CCAR, University of Colorado  
R.B. Miller and D. Jenkins, Z Systems, Arcadia, CA,  
J. Lemmon, Institute for Telecommunication Sciences, NTIA  
CU Graduate Students: K. Gold, W. Schreiner and G. Snyder

### Summary

CGAMP is meeting the challenge of exploiting the L-band signals from the Global Positioning System (GPS) satellites for the measurement of the impulse response of radio transmission channels over space-Earth paths. This approach was originally suggested by E.K. Smith and has been pursued by J. Lemmon, without an affordable implementation being identifiable (ref. 1). In addition to the high cost of a suitable P code correlating GPS receiver, there is also the major impediment of the often announced Department of Defense SA/AS policy of selective availability /anti-spoof that clouds reliable access to the wideband (20 MHz) P channel of the GPS signals without cryptographic access. A technique proposed by MacDoran utilizes codeless methods for exploiting the P channel signals implemented by the use of a pair of antennas and cross correlation signal detection.

### CGAMP System

Figure 1 illustrates the overall configuration of the CGAMP system. The antenna at the upper left in the diagram serves as the system reference with relatively high gain (22 dB) pointed at a selected space vehicle (SV). Because of the reference antenna gain, there is small multipath contamination relative to a broad beamed antenna desired in mobile communications. The second channel of the CGAMP system contains the antenna under test (AUT) with its upper hemispherical response resulting from low gain (e.g., 3 dB gain) and is shown in the upper right of the diagram.

The reference channel utilizes a hybrid digital/analog approach for recovering the P channel digital sequence and controlling its delay without a priori knowledge of the P code sequence. These codeless techniques are contained in references 2 and 3. The P channel is selected from the QPSK modulation using a Doppler shift compensated coherent conversion to baseband to achieve a stationary phase replica of the P code sequence arriving at the reference and AUT antennas at any instant in time.

Although the P code is a priori unknown in the CGAMP system, the system design extracts the direct sequence code chipping at 10.23 MHz, with its associated Doppler shift. It is that digital sequence which is used to suppress and spread the 1575.42 MHz L1 carrier in the GPS satellites. The recovered P code sequence is digitally delayed under computer control in increments of 456 nsec,

the approximate width of the 48 complex channel cross correlation processor, see Figure 2. The delayed digital sequence is then modulated onto the recovered carrier at an intermediate frequency stage of 35.42 MHz. This delayed replica of the P code channel serves as the reference channel for the cross correlation processor. Thus, no matter what pseudo random noise digital sequence is transmitted in the P channel, the signal derived from the reference antenna becomes essentially an exact replica of the signal from the selected SV but can be delayed by desired amounts up to 22.5 usec. That nearly exact replica then serves as the local code reference for correlating with the output of the AUT which contains all GPS satellites in view and is contaminated by multipath.

Because the GPS codes are of the code division multiple access type, the inter-code cross correlation products are very low. Thus, the cross correlation processor is able to select out only the AUT multipath signals caused by the SV in the beam of the reference antenna.

The cross correlation processor (Figure 2) operates with an active mixer, analog multiplier at the 35.42 MHz I.F. with a 500 Hz low pass filter playing the role of the integrator in the cross correlation function. Because the P code is actually available to that portion of the processor, the benefits from spread spectrum process gain are obtained. Specifically, the double sideband P channel chipping rate of 10.23 MHz creates a 20.46 MHz wide signal received at 1575.42 MHz which is coherently converted to an I.F. of 35.42 MHz. The process gain is the ratio of the 20.46 MHz modulation width to the 500 Hz width of the low pass filter following the multiplication operation. Further digital processing will decrease the effective detection bandwidth to even smaller values which will increase the processing gain. Thus, the process gain will be at least 46 dB.

As seen in Figure 3, the CGAMP design incorporates a calibration subsystem which is capable of synthesizing the combination of direct signal arrivals at the two antennas as well as creating a multipath-like signal delayed up to 22 microseconds from the direct signal and of weaker level by 20 dB. The calibrator creates a spread spectrum signal by using a 9 stage shift register clocked at 10.23 MHz which is coherently related to the first local oscillator which is shared between the Reference and AUT channels. The spread spectrum generator sequence can be phased to simulate a multipath arrival out to a delay of 51 microseconds. The system design sensitivity has been set to measure multipath of 17 dB below the direct signal path with total delay spreads up to 20 usec, a delay resolution of 10 nsec and temporal sampling rates up to 100 Hz. Two transportable multi-path measurement systems are in the process of being developed, one for NASA and the other for the ESA.

The following section will deal with the analytical equivalence of the CGAMP approach with those of the more conventional channel probe methods.

## Relationship between CGAMP and Conventional Channel Probe

The objective of the codeless GPS approach to multipath measurements is to measure the equivalent baseband impulse response of transmission channels over space-Earth paths using signals from the GPS satellites. It is therefore important to have a clear understanding of the correlator outputs in the proposed multipath measurement system and of their relation to the baseband impulse response.

In past channel probes designed and built at the Institute for Telecommunication Sciences the transmitted probe signal consists of a carrier which phase-modulated by a pseudonoise (PN) code; in the probe receiver the received signal is multiplied by locally generated probe signals which are in phase quadrature and in which the PN code is generated by a "slow" clock. Thus, the locally generated code is allowed to slip slowly in time relative to the received code. The resulting products of the received and locally generated signals are then bandpass filtered, so that for a given value  $\tau$  of the time lag between the received and locally generated codes, the outputs of the in-phase and quadrature channels of the probe receiver can be written as

$$\begin{aligned} I &= \int_0^T P(t-\tau) \cos \omega t [R_I(t) \cos \omega t + R_Q(t) \sin \omega t] dt \\ &= \frac{1}{2} \int_0^T P(t-\tau) R_I(t) dt \propto h_I(\tau) \end{aligned} \tag{1}$$

and

$$\begin{aligned} Q &= \int_0^T P(t-\tau) \sin \omega t [R_I(t) \cos \omega t + R_Q(t) \sin \omega t] dt \\ &= \frac{1}{2} \int_0^T P(t-\tau) R_Q(t) dt \propto h_Q(\tau) \end{aligned} \tag{2}$$

where  $P(t)$  is the binary-valued ( $\pm 1$ ) PN code,  $R_I$  and  $R_Q$  are the baseband in-phase and quadrature components of the received signal, respectively, and  $T$  is the integration time associated with the bandpass filters. Since the received signal is the convolution of the impulse response of the transmission channel with the transmitted signal, expressions (1) and (2) correspond to the convolution of the impulse response with the autocorrelation function of the PN code. Thus, for a sufficiently impulsive autocorrelation function (sufficiently high chip rate of the PN code), (1) and (2) correspond to  $h_I$  and  $h_Q$ , the in-phase and

quadrature components, respectively, of the complex baseband impulse response of the radio channel.

In the codeless GPS approach to channel probe measurements the signal from the high gain reference antenna is used in lieu of a locally generated signal. The reference signal is delayed relative to the signal from the antenna under test in two stages: a "coarse" time delay  $\tau_c$  which takes place at baseband and a "fine" time delay  $\tau_f$  which takes place at IF. The quad divider acts on the signal from the antenna under test. Thus, the I and Q channel outputs, analogous to (1) and (2) above, are

$$\begin{aligned}
 I &= \int_0^T P(t-\tau_c-\tau_f) \cos\omega(t-\tau_f) [R_I(t) \cos\omega t + R_Q(t) \sin\omega t] dt \\
 &= \frac{1}{2} \int_0^T P(t-\tau_c-\tau_f) [R_I(t) \cos\omega\tau_f + R_Q(t) \sin\omega\tau_f] dt \\
 &\propto h_I(\tau_c+\tau_f) \cos\omega\tau_f + h_Q(\tau_c+\tau_f) \sin\omega\tau_f
 \end{aligned} \tag{3}$$

and

$$\begin{aligned}
 Q &= \int_0^T P(t-\tau_c-\tau_f) \cos\omega(t-\tau_f) [-R_I(t) \sin\omega t + R_Q(t) \cos\omega t] dt \\
 &= \frac{1}{2} \int_0^T P(t-\tau_c-\tau_f) [-R_I(t) \sin\omega\tau_f + R_Q(t) \cos\omega\tau_f] dt \\
 &\propto -h_I(\tau_c+\tau_f) \sin\omega\tau_f + h_Q(\tau_c+\tau_f) \cos\omega\tau_f
 \end{aligned} \tag{4}$$

where  $P(t)$  is the GPS P-code, and  $R_I$  and  $R_Q$  are the baseband in-phase and quadrature components of the signal from the antenna under test. Although the I and Q channel outputs in (3) and (4) do not correspond to  $h_I$  and  $h_Q$ , it is easy to see that

$$I^2 + Q^2 \propto h_I^2(\tau_c + \tau_f) + h_Q^2(\tau_c + \tau_f) \tag{5}$$

and that

$$h_I(\tau_c + \tau_f) \propto I \cos \omega\tau_f - Q \sin \omega\tau_f \tag{6}$$

and

$$h_0(\tau_c + \tau_f) \approx I \sin \omega \tau_f + Q \cos \omega \tau_f. \quad (7)$$

The phase  $\phi$  of the impulse response can therefore be obtained from I and Q by computing

$$\begin{aligned} \phi &= \tan^{-1} \frac{h_Q}{h_I} = \tan^{-1} \frac{I \sin \omega \tau_f + Q \cos \omega \tau_f}{I \cos \omega \tau_f - Q \sin \omega \tau_f} \\ &= \tan^{-1} \frac{Q}{I} + \omega \tau_f. \end{aligned} \quad (8)$$

Thus, the correlator outputs in CGAMP yield the same information (amplitude and phase of the impulse response) as conventional channel probes.

#### REFERENCES

1. Lemmon, John J., "MULTIPATH MEASUREMENTS FOR LAND MOBILE SATELLITE SERVICE USING GLOBAL POSITIONING SYSTEM SIGNALS," Proceedings of the NAPEX, May 1988.
2. Spilker, J.J., Digital Communications by Satellite, Prentice-Hall, Inc., Englewood Cliffs, New Jersey, 1977
3. MacDoran, P.F., R.B. Miller, L.A. Buennagel, H.F. Fliegel, and L.Tanida, "Codeless GPS Systems for Positioning of Offshore Platforms and 3D Seismic Surveys", NAVIGATION: Journal of the Institute of Navigation, ION Vol. III on the Global Positioning System, Pgs 147 to 159, 1986.

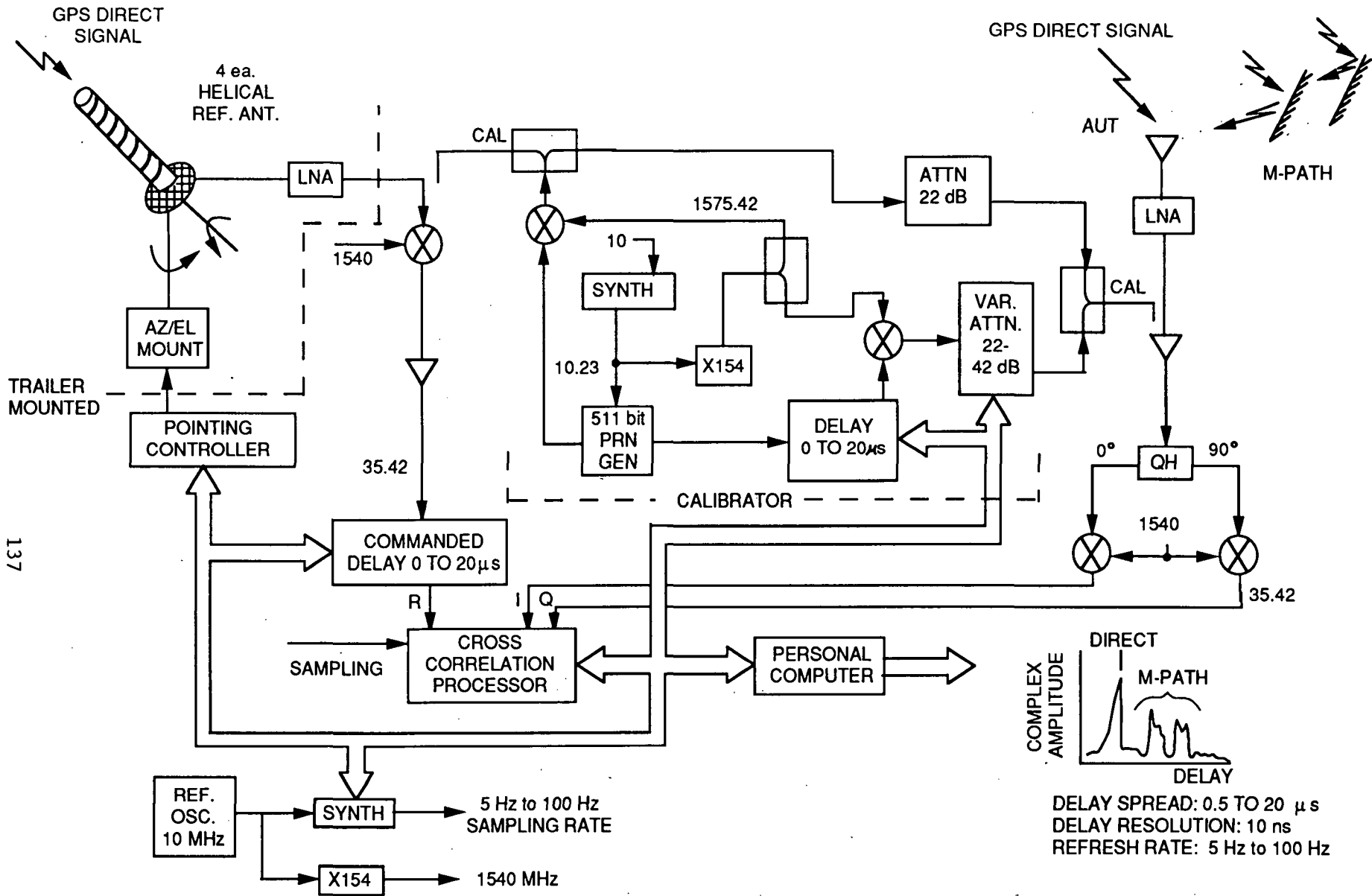

# CODELESS GPS APPLICATIONS TO MULTI-PATH (CGAMP)

FIGURE 1

PFM  
14MAY90

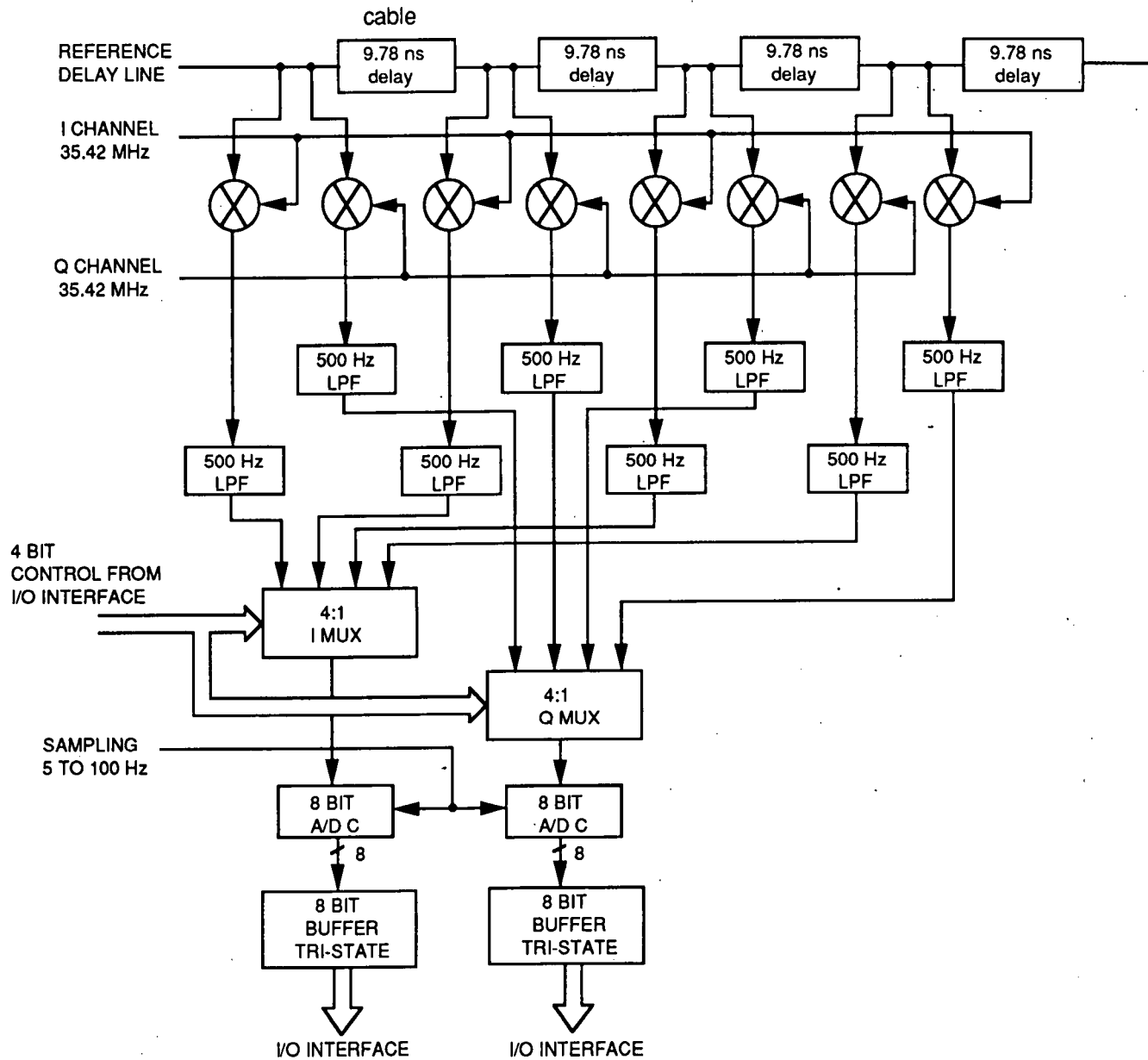

## FOUR CHANNEL COMPLEX CORRELATOR BOARD (12 REQUIRED)

14MAY90

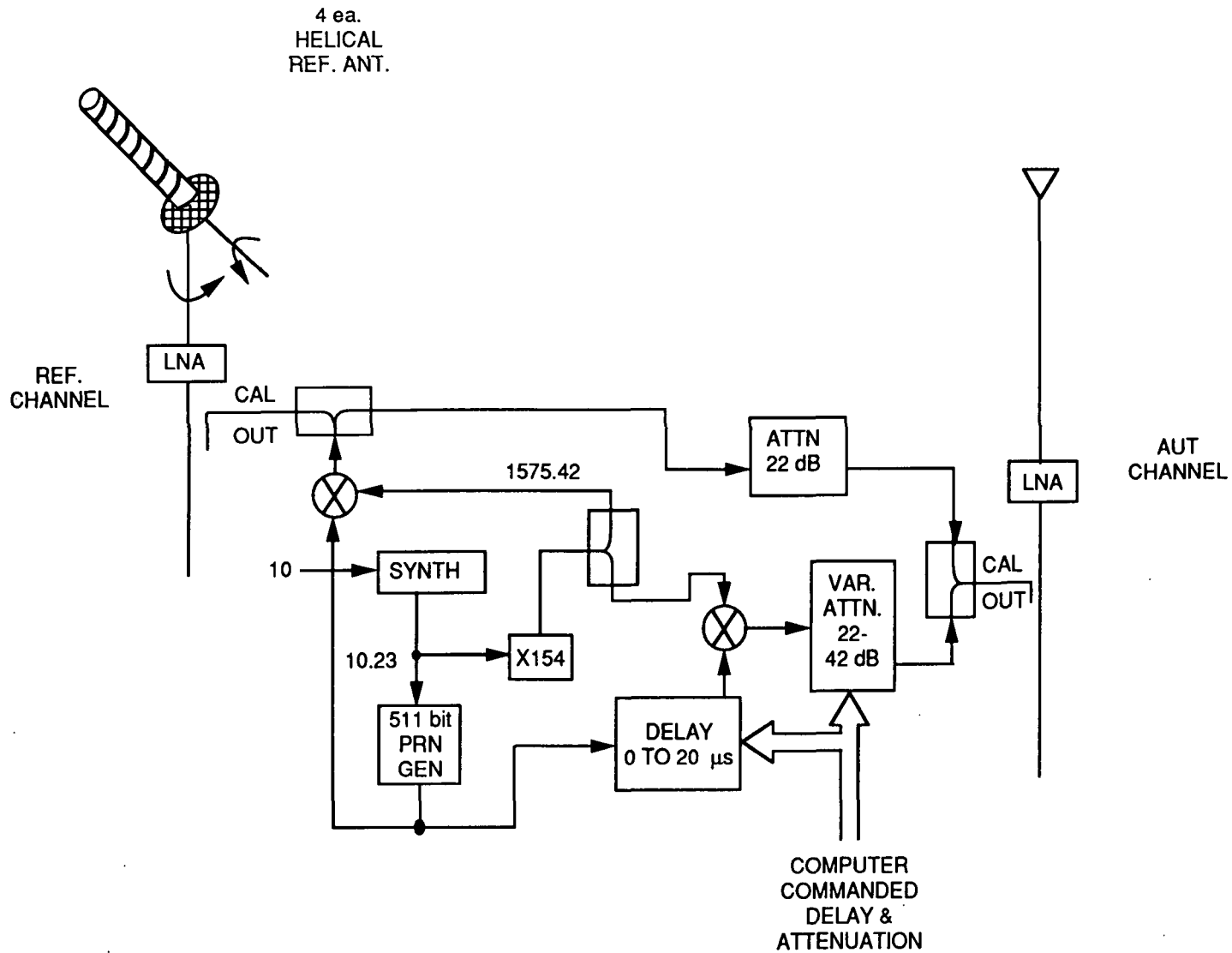

**CALIBRATION SUB-SYSTEM BLOCK DIAGRAM**

FIGURE 3