

IN-35-CR

311537

P-24

Semiannual Status Report for NASA
Grant Number NAG-1-1133:
*A Quiet Flow Ludwig Tube for Study of
Transition in Compressible Boundary
Layers: Design and Feasibility*

Principal Investigator:
Professor Steven P. Schneider
School of Aeronautics and Astronautics
Purdue University
West Lafayette, IN 47907

Period Covered By Report: 1 May 1990 to 1 November 1990

(NASA-CR-187374) A QUIET FLOW LUDWIG TUBE
FOR STUDY OF TRANSITION IN COMPRESSIBLE
BOUNDARY LAYERS: DESIGN AND FEASIBILITY
Semiannual Status Report, 1 May - 1 Nov.
1990 (Purdue Univ.) 24 p

N91-13676

Unclass

CSCL 14B G3/35 0311537

Contents

1	Introduction	1
2	Design Overview	2
2.1	General Description	2
2.2	Sizing of Tube	6
2.3	Contraction and Test Section	7
2.4	Valve Location and Type	7
2.5	Second Throat, Diffuser, and Vacuum System	8
2.6	Compressor and Filter System	9
2.7	Safety Issues	10
2.8	Other Issues	11
2.9	Ludwig Tube Equipment Cost Estimate	13
3	Quiet-Flow Supersonic Nozzle Design Methods	14
3.1	Inviscid Compressible Design	15
3.2	Laminar Viscous Boundary Layer Computation	17
3.3	Computation of Laminar Boundary Layer Instability	18
4	Quiet-Flow Supersonic Nozzle Fabrication Methods	18
5	The 2 Inch Purdue Supersonic Wind Tunnel: Modifications for Low Reynolds Number Quiet Flow	21
6	Summary	21
7	References	22

1 Introduction

This grant supports an investigation into the feasibility of creating a Quiet-Flow Ludwig Tube for the study of compressible boundary layer transition. Since Ludwig tubes have been around for many years, and NASA Langley has already established the feasibility of creating quiet-flow wind tunnels, the major question to be addressed was the cost of the proposed facility. Cost estimates were obtained for major system components, and new designs which

allowed fabrication at lower cost were developed. A large fraction of the facility cost comes from the fabrication of the highly polished quiet-flow supersonic nozzle. Methods for the design of this nozzle were studied at length in an attempt to find an effective but less expensive design. This design is not yet complete. Less expensive methods for nozzle fabrication have also been investigated, and a test specimen for the fabrication techniques has been fabricated. Progress has been sufficient to show that a quality facility can be fabricated at a reasonable cost. Instrumentation and fabrication techniques are being further investigated through modification of the small Purdue supersonic wind tunnel in order to achieve quiet flow at low Reynolds numbers.

The general design and most cost estimates are discussed in the first section. Computation methods used there but not specifically discussed were taken from Pope and Goin [13]. The test section configuration and shape involves many special considerations and a large fraction of the facility cost. Design methods for the test section are discussed in the second section. Fabrication methods have a major impact on the test section cost and are discussed in the third section. Finally, some upgrades to a small blow-down tunnel for the purpose of low Reynolds number work and instrumentation tests are discussed.

2 Design Overview

2.1 General Description

The Ludwieg tube wind tunnel is a long pressurized tube with a supersonic nozzle on the end (see Figures 1 and 2). When the quick-opening valve opens, fluid flows from the tube through the contraction, throat, and supersonic expansion, through the test section, past the second throat, and into a vacuum tank. After some startup time which depends on model size, valve opening time, and test section configuration, the test section flow is essentially steady. The rapid expansion of gas from the tube sends an expansion wave upstream into the tube. This wave reflects off the far end of the tube; on its return to the test section, the useful test time has ended. At this point, the tube and test section are still pressurized. Fluid continues to flow into the vacuum tank until atmospheric pressure is reached downstream, and

Ludwig Tube Sketch

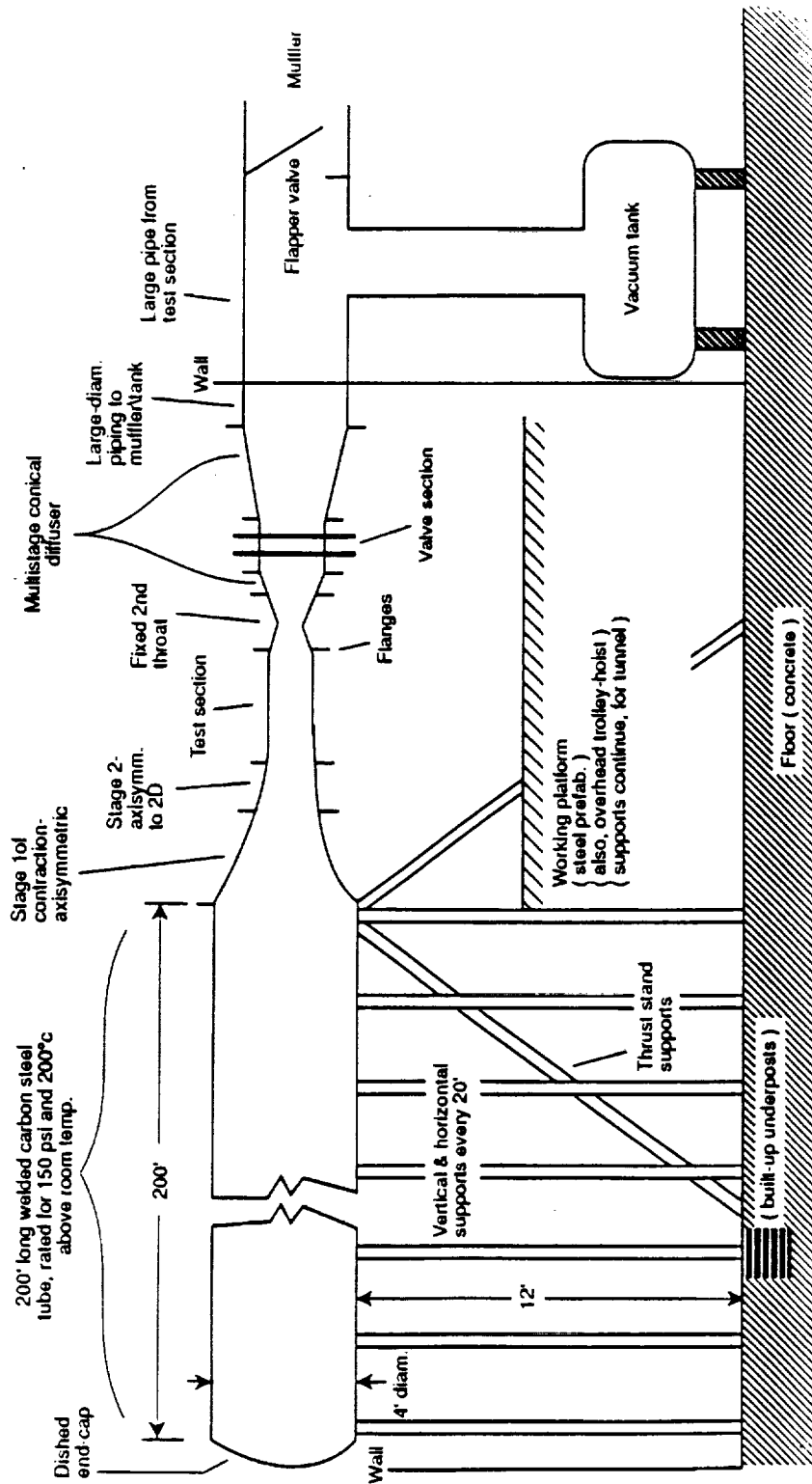

Figure 1: Ludwig Tube Sketch

Ludwig Tube - Plumbing Schematic

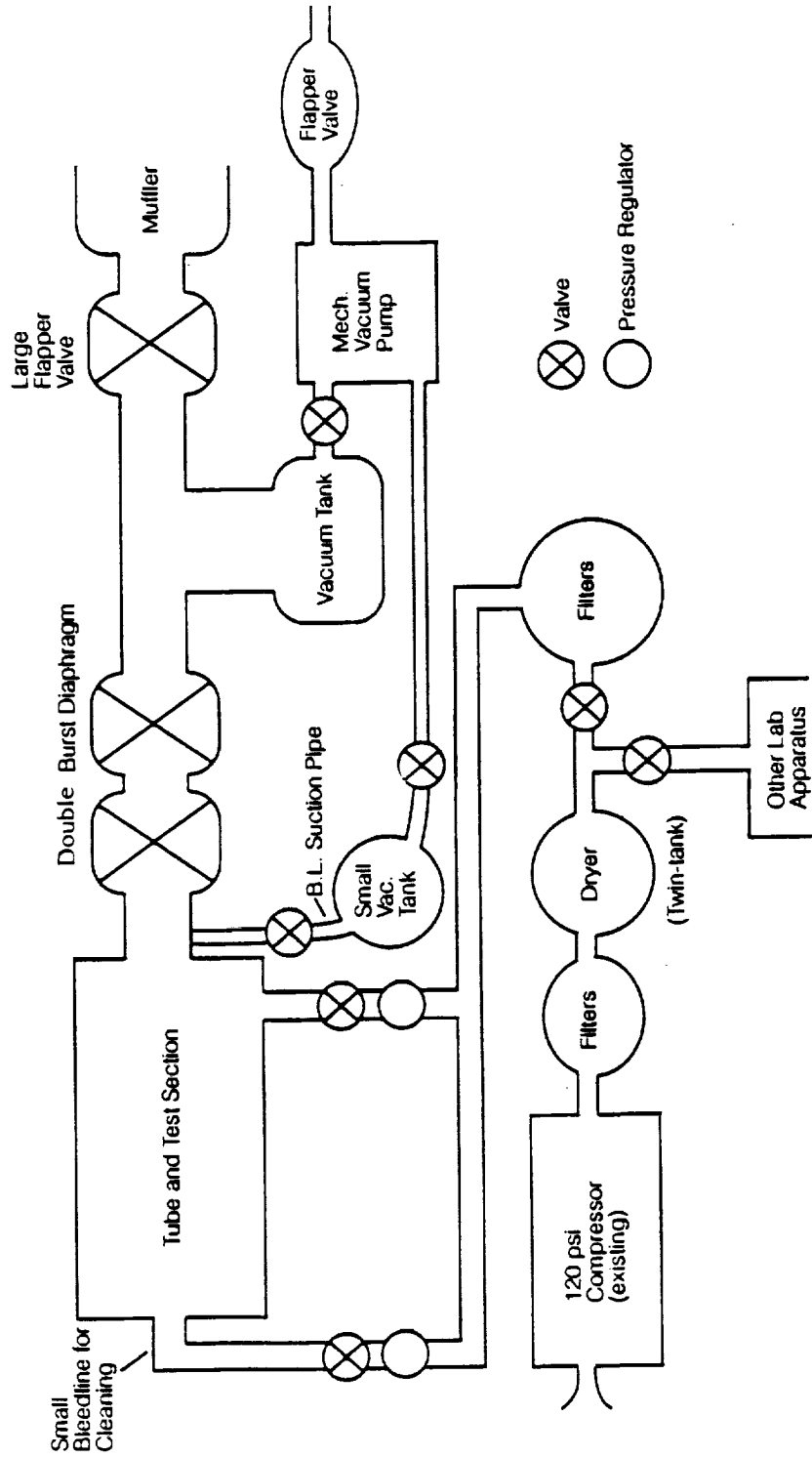

Figure 2: Ludwig Tube Plumbing Schematic

then blows out the flapper valve into the atmosphere until the tube has depressurized. The vacuum tank allows runs to be made at low total pressures, and assists in starting higher pressure runs. Various forms of the Ludwieg tube are described in references [11], [18], [16], [14], and [10].

The tube will be used for quiet-flow study of boundary layer transition. Here, it is desirable to reach transition Reynolds numbers on a flat plate, at all Mach numbers for which heating is unnecessary. The thickness of the laminar boundary layer on the model flat plate was estimated using compressible boundary layer similarity theory. The equations were rederived following White ([17]). A computer program was written to solve the boundary layer and isentropic expansion equations and to generate a table of test section Mach number, stagnation pressure and temperature, model length required to reach transition Reynolds number, and so on. This table was used to create various contour plots to optimize the design choices. It became obvious that the best way to design the tunnel was to make the largest possible test section, so that the model and tunnel wall boundary layers are as thick as possible.

Maximum allowable tunnel pressure should be sufficient to reach flight transition Reynolds numbers at the highest Mach number of interest, with a plate that will fit in quiet-flow part of the test section. Since quiet-flow nozzle design is non-trivial, only estimates can be made at this stage. If a quiet-flow length of about half a meter can be obtained, then a stagnation pressure of 150 psi is sufficient to reach the transition Reynolds number¹ of 2.1×10^7 at Mach 4. Higher Mach number work would require a larger quiet-flow test section or a higher pressure. The initial test section is to be 15 inches wide, so that it can be machined in the Purdue Central Machine Shop numerically controlled mill. A reasonable test section height of about 6 inches makes for a mass flow rate of about 10 kg/sec.

The useful tube run time also depends on the length of time needed to establish the flow. Work by Johnson et al. [9] showed that as expected this starting time is several times the time needed for a particle to cross the test section (i.e., roughly 10-20 milliseconds). Although workers in the AEDC tube struggled with a much longer startup time, this was due to the other issues involved with their transonic test section and its slotted wall (see [16]).

¹Extrapolated from flight data presented in [5, Figure 8].

2.2 Sizing of Tube

The length of the driver tube governs the useful flow duration; the longer the tube, the longer the useful flow. The Aerospace Sciences Laboratory at Purdue University is a 250 foot long aircraft hangar which has been converted to a lab. If 50 feet is allowed for the test section, valve, diffuser, and so on, then there is room for a 200 foot long tube. In order to make such a long tube useful, it must have sufficient diameter. A boundary layer grows behind the expansion wave propagating into the tube. The displacement thickness effect of this layer causes a pressure variation in the test section which must be small for good flow. An experimental correlation for this variation is given by Russell et al. [14, Equation 1]. This variation depends on the mass flow rate out of the tube, which in turn depends on the contraction ratio and the test section size and Mach number. It would be desirable to make the tube large enough to allow for the future use of larger test sections, so that thicker boundary layers can eventually be studied.

Tube diameters of from 2 to 4 feet are a reasonable match for the tube length; tube cost seems to vary linearly with diameter and pressure, and tube cost is only about one sixth of the cost of the entire facility. The current plan is to use a tube of 4 feet in diameter; the displacement thickness at the end of the run, with the design test section size given above, is only 0.042 inches. The fluid only moves 2 feet along the tube during the useful run. The useful flow duration will then be governed by the 200 foot tube length and corresponds to about 350 milliseconds at room temperature. This large tube would allow for the use of a test section throat 2 feet in diameter, with a pressure change due to boundary layer growth of 0.03% during the course of a run. Such a large throat might be needed for near-sonic runs with a lower Mach number test section. A smaller and higher pressure tube may be used in the final design depending on the other choices made and available funds.

A quotation of \$51,664 has been obtained for site fabrication of a 200 foot long tube 4 feet in diameter, with ASME code stamp, designed for 150 psi and 200°C above room temperature. The heating capacity does not involve any extra cost - this is merely the capability of the material which would otherwise be needed. This quotation includes mounting 12 feet above ground on supports provided by us, and includes all testing required by Indiana State regulations, including the head required for testing the flanged

end. This quotation was for delivery in early 1990.

2.3 Contraction and Test Section

Plans are to make the contraction in two parts with a flanged joint. This will allow for varying test section size without replacement of the entire contraction, and the joint should not give trouble when placed reasonably far upstream. The contraction is to be cast from carbon steel about 1 inch thick using a special one-time casting technique (stryfoam mold), and then machined axisymmetric to a specified contour using a tracer lathe. A price estimate of \$16,000 was obtained from Frankton Machine and Tool, Inc., of Indiana; a slightly higher quotation was obtained from another firm. This cost is insensitive to contraction thickness and also insensitive to diameter (reduction of diameter by factor 2 reduces cost by about 30%). An extra \$9,000 has been budgeted for the extra costs involved in building the contraction to ASME code; extra costs will also be involved if the second part of the contraction involves a transition from axisymmetric to 2D. These costs will depend on the diameter at which the transition is made.

The detailed design of the test section is discussed in a later section. A general issue involves the choice of a 2D or axisymmetric test section. Current plans are for a 2D test section, which is easier to machine and polish, and which allows easy optical access. Nozzle housings can be designed which allow for interchangeable nozzle blocks for different Mach numbers. However, axisymmetric test sections do not have problems with side-wall boundary layer contamination or corner vortices. It might also be possible to make a mandrel for an axisymmetric test section on a diamond turning lathe and obtain a high-quality surface without polishing. Such an axisymmetric nozzle would have to be machined with tighter tolerances on the surface contour, to avoid difficulties with focusing of weak shocks on the centerline.

2.4 Valve Location and Type

For quiet test section flow, the valve must be located downstream of the test section. Otherwise, disturbances generated by the open valve will disturb the flow. This means that a large diameter valve must be used, for the tunnel flow area is smallest at the first throat, and much larger at the second throat and downstream. For a test section of sufficient size the downstream flow

area corresponds to a diameter larger than 12 inches. The valve must open in a time the order of 10 milliseconds so that it does not significantly reduce the runtime. Mechanical valves of this type seem to be very expensive. Thus it seems preferable to use a burst diaphragm for this tunnel, just as is done in shock tubes. Current plans are to use a pair of burst diaphragms. The tunnel is pumped up to half pressure, and air is bled into the area between the diaphragms. Then the tunnel is fully pumped up. After air is bled into the region between the diaphragms, the second and then first will burst at a time controlled by the bleed time. This allows for more precise control of the tunnel total pressure and thus the test section Reynolds number. The burst diaphragm design could be adapted from those used on the Caltech shock tubes (drawings would be made available) or from those used on double diaphragm systems at CALSPAN.

If a mechanical valve capable of rapid closure were obtained, then successive runs could be made without complete depressurization of the tube, saving on pumping costs and time. However, a valve with appropriate specifications (about 1 square foot of open area, opening time about 10-20 msec) seems unavailable without custom engineering at a prohibitive cost (upwards of \$50,000). This option seems best reserved as a future possible upgrade to the system, should it seem desirable; it would be easy to bolt in a new valve if one was fabricated or obtained.

2.5 Second Throat, Diffuser, and Vacuum System

A variable second throat allows for better pressure recovery in a supersonic wind tunnel, but for a Ludwieg tube the flow time is fixed by the tube length and not the pressure recovery. The cost of a larger vacuum tank is much smaller than the cost of a variable second throat. Thus, we anticipate using a fixed second throat, with its geometry linked to the test section geometry.

A conical diffuser is a relatively inexpensive way of getting pressure recovery downstream. Since test sections of varying size are envisioned, it seems best to make the diffuser in two parts, so that the first only can be varied for smaller test sections. This also allows for the use of one valve of fixed size for a range of test sections.

The size of the downstream exit plumbing is a limitation on the size of the test section. This downstream plumbing can be made in Purdue University shops at relatively low cost, since it does not have to be ASME code stamped

(not pressurized in normal operation). Large pipe flanges, in particular, have to be custom made; the largest pipe flange which the Central Shop is capable of making is for pipe of about 30 inch diameter. Thus, plans call for 30 inch diameter piping.

The vacuum tank size is controlled by the run time and by the mass flow rate. Since the run time is short a small vacuum tank can be used; this is a very large cost savings. A vacuum tank of 500 cubic feet is being procured for use in the upgraded Purdue Supersonic Wind Tunnel and this tank will be fitted with a 30 inch diameter welded cap so that it can be readily hooked up to the Ludwig tube outlet piping. This size is sufficient to run the tube at about Mach 4 for the full 350 msec as long as the flow total pressure is at least about 5 psia (assuming the vacuum pump can bring the tank down to 0.01 psia). At lower Mach numbers the run-time would be reduced if the total pressures were this low. This tank is being procured using funding from NASA Grant NAG-1-1133 and the School of Aeronautics and Astronautics at a total cost of about \$14,000, including footings. The purchase order has already been written; approval for reallocation of funds has just been received from NASA.

A Stokes Model 212-H 150 CFM vacuum pump has been retrieved from storage and is being restored to running condition. This pump can pump the 500 cubic foot tank down to 0.01 psia in about 35 minutes, and is capable of reaching an ultimate vacuum of 10 microns of mercury, which is much less than will be required.

The flapper valve is necessary to exhaust the flow when the tube is depressurizing after the test is over and the vacuum tank is full, or, for higher pressures, for direct flow from the tube. Such a valve can be fabricated easily as a hinged cover to the end of a pipe tee.

2.6 Compressor and Filter System

Since the system will be constructed from scratch to be a quiet flow tunnel, the whole system can be maintained like a clean room. This allows the air to be filtered during the slow pump-up phase rather than during the rapid air flow testing phase, making the filters much cheaper. Appropriate filters can then be obtained for a few thousand dollars.

A Van Air Model 350-HL twin-tower heatless dryer is present in the existing system. A precision dewpoint sensor capable of measuring dewpoint to

$-120^{\circ}C$ has also been obtained and is being installed. This sensor includes electronics which should make it easy to control the switching of the dryer towers in response to the gas humidity.

The Aeronautics supersonic facilities include an Ingersoll-Rand PA50 215SCFM 120 psig compressor which would also be used for the Ludwieg tube. This compressor is capable of pumping the the 4 foot diameter 200 foot long driver tube (2000 cubic feet) up to 135 psia in about 200 minutes, allowing for several runs in a normal working day. A second stage compressor would have to be added for higher pressure work, at higher Reynolds numbers. A matched oil-free second stage compressor capable of reaching 335 psig at the same flow rate was priced from Corken International at about \$14,000; a lower pressure unit would be less expensive. This item has not been included in the budget, for it currently does not seem essential to the initial plans.

2.7 Safety Issues

Purdue University safety office personnel (Mr. Mike Kopas and others) have been included in planning from the early stages. All Purdue pressure vessels must be in accordance with the rules established by the Indiana State Boiler and Pressure Vessel Rules Board. Contact has also been established with this Board, through the secretary Mr. Bud Meiring. One of the Board members is a Purdue faculty member, Prof. Jim Hamilton, which facilitates communication. An ad hoc committee of the School of Aeronautics and Astronautics has been formed to consider facility safety issues and has been kept aware of the facility safety issues.

Since the tube is to be an approved pressure vessel, the Safety Office does not see a problem with the tube being in the same room as the machinists, students, and other building occupants. The price estimate for the tube includes fabrication and installation by an Indiana State approved pressure vessel manufacturer in accordance with the ASME Pressure Vessel Code (section VIII, division I). It appears that the contraction will also have to be fabricated and code stamped by an approved manufacturer; this extra cost has been estimated in the budget also. The test section, initial diffuser, and valve sections are the only other sections which are pressurized for long periods of time to high pressures. Since it would be awkward to have these pass through the hands of a third party manufacturer, the plan is to de-

sign these in accordance with the Code and have the designs checked by a professional engineer familiar with the relevant codes and standards. These sections would then be fabricated by the Purdue Central Machine Shop and hydraulically tested. It should be noted that ASME Code approved welders are available on campus. The sections would then be approved and operated as Indiana State Special pressure vessels, a not unusual procedure for this kind of special university facility, according to Professor Hamilton. Plans call for designing the test section so that the pressure containment vessel is independent of the supersonic nozzles, as in the Soviet supersonic wind tunnels at Novosibirsk.

The tube components downstream of the valve are not normally pressurized (although they will sustain some pressure during operation) and thus need to conform to the ASME Piping Code rather than the Pressure Vessel Code. No special fabrication stamps are then required. These sections are to be fabricated from standard steel piping by the Purdue Central Machine shop and other Purdue machinists and welders. Copies of the relevant portions of the ASME Pressure Vessel and Piping Codes have been obtained for assistance in the design.

The driver tube supports and the test section working platform will be designed and installed by Purdue internal departments to usual standards acceptable to the Safety Office. Estimates for these components were obtained and are presented in the budget.

Thus, the only safety issue which appears to impact the cost of the facility is the requirement for the tube to accord with the pressure vessel codes. The long driver tube will be contracted out to a pressure vessel manufacturer, following the usual procedure. The smaller test section area components will be designed and fabricated in house, and then pressure tested. Considerable consultation has revealed no other major safety related expenses.

2.8 Other Issues

The Ludwig tube will make a considerable amount of noise while the flow is dumping to atmospheric. Fortunately, the Aerospace Sciences Lab is located in an area where the creation of loud noises is acceptable. The lab is at the Purdue University Airport, within 100 yards of the end of the principal runway. Regularly scheduled propeller planes and occasional jets land very close, so the added noise will not be all that noticeable. There is no private

land nearby, and the nearest student housing is about a quarter mile away. The noise from the tube blowdown can be roughly estimated using results obtained by Starr ([16]). For a somewhat different configuration, he gives data showing that the noise would be about 100dB at 200 feet, without any muffling, which is the limit given for residential areas. Since the nearest residential areas are much further away, a minimum amount of muffling should make the flow acceptable. It may be desirable to add more muffling later if discomfort to operators and building occupants is large; this seems best determined after installation.

Although the Aerospace Sciences Lab has the 250 foot length needed to contain the tube, there is not enough floor space for it. Fortunately, it is 18 feet from the floor to the building rafters, so there is plenty of room for supporting the tube above the floor. Plans call for 12 foot columns spaced every 20 feet to support the tube. The building columns are also spaced 20 feet apart and will be tied into the support columns to stabilize the tube laterally. A 20 by 50 foot mezzanine will be built using standard steel mesh platforms to provide a floor at a convenient height for the area around the tube test section. This mezzanine will also include posts necessary to support the test section. Furthermore, a one ton trolley and hoist will be installed to allow easy installation and modification of the test section area tunnel elements and models. These building modifications will be carried out by Purdue internal departments and the costs presented in the budget represent formal estimates prepared by them.

Finally, the reaction loads from the tunnel flow need to be accounted for. The maximum force can be conservatively estimated from the sonic velocity at the nozzle throat times the maximum mass flow rate there. For the initial test section, this comes out to be about 1000 pounds of force. Thus, reaction load bracing can be limited to guy wires fastened to the floor. If larger test sections are eventually constructed more elaborate reaction load bracing may have to be constructed.

2.9 Ludwig Tube Equipment Cost Estimate

	Year 1	Year 2	Year 3
I. Site Renovation and Building Preparation			
Posts and ties to mount driver tube in lab	5,000		
Floor rework to enable posts to bear weight of water pressure test	7,000		
Build working platform and hoist at test section end	23,000		
Small outbuilding for compressors		22,000	
subtotal: Site Preparation	35,000	22,000	
II. Driver Tube			
48 in. diameter pressure vessel, 200 feet long, with flange for contraction end, including welding, pressure test, and all Indiana state requirements, for 150 psi working pressure, and for operation at up to 225°C, to be erected on site	60,000		
subtotal: Driver Tube	60,000		
III. Contraction and Test Section			
Two stage contraction	25,000		
Pressure containment box		18,000	
Boundary layer suction system		7,000	
Supersonic quiet-flow nozzle blocks	60,000	55,000	
subtotal: Contraction and Test Section	85,000	80,000	
IV. Compressor Air Delivery System			
Air drying system modifications		3,000	
Oil and particle filters		3,000	
Pressure relief valves		2,000	
Pressure gauges, control panel instrumentation, etc			6,000
subtotal: Compressed Air System		8,000	6,000
V. Diffuser and Outflow System			
Diffuser sections		7,000	
Double diaphragm section	9,000		
Fixed second throat		4,000	
Flapper valve		5,000	
Pipe from valves to muffler			5,000
Muffler			5,000
subtotal: Diffuser and Outflow System	9,000	16,000	10,000
VI. Model and Instrumentation			
			30,000
Total Direct Costs:	\$189,000	\$126,000	\$46,000
TOTAL PROJECT DIRECT COSTS (Equipment only):		361,000	
Less Department cost-sharing		-50,000	
DIRECT COST TO SPONSORS (Equipment only):		\$311,000	

3 Quiet-Flow Supersonic Nozzle Design Methods

The author had the privilege of spending eight weeks of the summer of 1990 studying quiet tunnel design at NASA Langley, which has the only high Reynolds number quiet facility in the world. The main purpose of this trip was to learn the design methods developed by the lead engineer, Ivan Beckwith, and his coworkers, which include nozzle designer Frank Chen. Although the author suggested and implemented several modifications to the existing methods the framework of this discussion is that of the Langley quiet tunnel design methods. The author has been involved in this field for less than a year and has not had the opportunity to evaluate very many of the alternatives.

Inherent to the idea of a supersonic nozzle is the design of the walls, following inviscid supersonic flow theory, in order to produce a shock free isentropic expansion to a uniform parallel flow, which is the usual test section requirement. This nozzle design is complicated by the requirement for a suction slot upstream of the nozzle throat to suck off the contraction wall boundary layer. This inviscid part will be discussed in the first subsection. Since the test section necessarily has viscous boundary layers, these are often computed to allow for a correction to the nozzle wall shape. This correction is discussed in the second subsection. Finally, for a quiet flow test section, it is important that the nozzle wall boundary layers be kept laminar as long as possible. The stability and transition of the boundary layers can be estimated using roughness estimates and e^N theory discussed in the third subsection.

The design method current when the author arrived at Langley in June 1990 involved the use of three separate computer codes, run on the old Langley NOS Cyber 205 machines. These machines have primitive operating systems, and the use of the codes involved a considerable amount of data file editing using primitive editors. The complete analysis of a single nozzle shape involved a great deal of operator intervention, and a considerable amount of waiting - a matter of weeks was involved. Since the author was interested in finding an optimum shape the streamlining of this process was a high priority. This streamlining was achieved by adapting the design codes into modern FORTRAN-77 (from FORTRAN IV) and porting them to modern machines. The codes were run separately, as before, but special output files were written from each code in a form suitable for direct use as the input

file to the next program in the chain. This scheme will allow the complete series of codes to be run automatically on a specified nozzle shape through use of a command or batch file. Thus, several nozzle shapes can be investigated in the course of a single night's computer run, instead of several weeks of computation and editing. The scheme is not complete, due to problems encountered in upgrading from the old stability program GORTLER to the new version E**MALIK. However, it has been successful so far, and promises to make the design process faster and simpler.

3.1 Inviscid Compressible Design

Inviscid supersonic nozzle design is not yet a standardized procedure. A good recent tutorial is contained in the textbook by Zucrow and Hoffman [19, Sections 15-5 and 16-4]. The author has had the benefit of several long discussions with Professor Hoffman, also at Purdue, who specializes in nozzle design, although of the rocket variety. The supersonic flow is hyperbolic, so that downstream conditions are set by conditions upstream, and the flow is computed using the method of characteristics. However, the boundary conditions to be used are a matter of design judgement. Computations normally begin in the nozzle throat, with the best computations using a transonic perturbation scheme to compute the flow near the throat, assuming the flow is nearly parallel there. Thus, the upstream subsonic flow must deliver a nearly parallel flow in the throat. These transonic perturbation schemes are only valid for Mach numbers very near 1, and require as input some information regarding the shape of the nozzle near the throat, usually in the form of the throat radius of curvature (the higher order terms usually being neglected).

For earlier NASA Langley designs these transonic perturbation approximations for the throat have been extended upstream to find the inner contour of the boundary layer bleed lip. However, the only requirement for this inner bleed lip is that it deliver parallel flow to the nozzle throat. The designer thus has a range of choices for this upstream contour which can be used to simplify the mechanical and structural design. The outer side of the bleed lip has in the past been designed to simple curves, requiring only that the flow not be turned too dramatically, and that the bleed slot contain a sonic region to reduce the amount of noise which can propagate into the test section. This seems reasonable, give the limited number of requirements on the slot geometry.

Besides the inputs required for this transonic calculation, the nozzle design also requires some further inputs. This further input can take at least two forms: First, the designer can specify the distribution of Mach number along the nozzle centerline for some distance (until the downstream parallel flow requirement takes over), or second, the designer can specify the initial shape of the nozzle wall (again, until the downstream parallel flow requirement takes over). Thus, an inviscid nozzle computation requires the designer to specify conditions in the transonic portion of the nozzle and in the initial supersonic region. These requirements are in addition to the specification of parallel exit flow and exit flow Mach number.

The design method used for existing Langley quiet nozzles² involved an inviscid flow code adapted by Frank Chen from the Nelms minimum length nozzle code [12]. The Nelms code was originally written to design supersonic rocket nozzles for minimum length. This kind of design involves the use of a sharp corner expansion in order to produce the minimum length. Chen's code used Hopkins and Hill's perturbation technique [8] for computing the transonic flow in the throat, at least for the axisymmetric nozzles. The sharp nozzle corner, inappropriate for a wind tunnel nozzle, was avoided by using for the nozzle contour one of the inner inviscid streamlines; this technique is discussed in Nelms' paper. The particular streamline chosen was unclear. The technique was modified in the late 1980's to add a region of radial flow between the initial expansion region and the region where the wall is shaped to turn the initial characteristics so as to produce a uniform exit flow. This radial flow region allows the boundary layer to grow without any concave curvature and was thought to reduce the Gortler instability problem.

Since Chen's source code was unavailable, not documented, and ran only on the old NOS machines, an alternative was sought. A search of available codes unearthed the Sivells design code [15]. This code was specifically designed for production of wind tunnel nozzles, and incorporated various special considerations to improve the uniformity of the flow. The program was well-documented, reasonably well written, and source code was available. The program computes both 2D and axisymmetric nozzles, and its author was recommended by Ivan Beckwith as a person who did careful work and produced good quality nozzle designs. Furthermore, this program allowed

²See, e.g., [4]. Frank Chen has not written any detailed description of the nozzle design procedure. Descriptions of existing procedure are based on discussions with Frank Chen.

for the use of a variable region of radial flow, just as had been incorporated into the Chen code.

The Sivells code was acquired with the aid of Charles Johnson of NASA Langley, and adapted to run in FORTRAN-77 on an IBM AT clone. The code allows the use of a simple turbulent boundary layer computation scheme, which is not used. It incorporates the Hopkins and Hill transonic flow scheme, which has also been adapted for use in 2D nozzles in a carefully documented way. Upstream nozzle conditions are specified through specification of the Mach number distribution on the nozzle centerline. This distribution is kept continuous to keep continuous second derivatives in the nozzle wall shape, a condition which may be required in order to achieve smooth flow. The free parameters which control the nozzle shape are easily set, and the program runs on an 8MHz IBM AT clone in a few minutes, allowing a large number of nozzle shapes to be easily investigated. A subroutine was added to the code to print a special output file of the exact form needed for the boundary layer computation code, so that rapid computation of all the nozzle parameters can be achieved in a batch file without operator intervention.

3.2 Laminar Viscous Boundary Layer Computation

The existing Langley design method used a FORTRAN-IV version of the code written by Harris and Blanchard [7] to compute the viscous boundary layer. This code had been heavily modified to change the output form and to produce wall radii of curvature information for the stability computations. Since this made debugging and testing the code difficult, it was decided to get a current FORTRAN-77 version of the code direct from Harris and Blanchard (through Venkit Iyer at Langley), and write a separate program to take the standard output form and specialize it. This was done. The code runs on the IBM AT clone in about 30 minutes, with a reasonable grid, and would run much faster on a bigger machine. It has been tested on one of Harris' standard test cases. A new subroutine was also written for this code to produce output in the right format for direct input to the compressible stability code E**MALIK.

3.3 Computation of Laminar Boundary Layer Instability

The test section design requires an estimate of the position of boundary layer transition on the tunnel walls. Sound is radiated downstream along Mach lines from the initial location of transition and from the turbulent boundary layer downstream. This sound contaminates the flow at all positions downstream of the Mach line from the location of transition. The length of the quiet-flow test core in the test section is determined by the streamwise distance between the beginning of uniform flow and the end of quiet flow. Design of a test section for maximum length of quiet flow thus depends on moving the transition as far downstream as possible.

The existing version of the Langley nozzle design methods involved the use of the GORTLER instability code written by Malik, which computed Gortler instability on the nozzle walls. This was used since it was discovered that Gortler instability was primary for the designs usually used. The code computes the maximum growth of Gortler disturbances, using an e^N technique. However, this code involved a great deal of operator interaction, since only one Gortler wavelength could be tested at one time. It was decided to use instead the new version of Malik's instability codes, E**MALIK, which computes Tollmien-Schlichting type instability as well as Gortler instability, runs more automatically, and is written in FORTRAN-77 instead of FORTRAN-IV. Dr. Malik graciously supplied the source code for this program; however, the version supplied was old and contained bugs. The author spent the last few weeks of his stay at Langley learning to use the code, and struggling with various problems. During the last week he was helped by another user, who also informed him that there was an updated version, which was free of these bugs. This updated version has been obtained but the author has not yet applied it to the nozzle problem.

4 Quiet-Flow Supersonic Nozzle Fabrication Methods

The crucial issue in quiet-flow supersonic nozzle design is the delay of transition relative to the initial location of the uniform flow region, in order to maximize the quiet-flow test core. Besides contouring the nozzle to tailor the

pressure gradient and curvature in order to reduce the growth of instability waves, it is also necessary to smooth the tunnel walls so that transition is not tripped by small roughness elements, which can be large compared to the thin accelerating supersonic boundary layer. Besides the absolute tolerances and the roughness tolerances, intermediate scale waviness tolerances are also specified so that weak shock waves are not produced by locally large errors. Existing Langley nozzles are built to very tight absolute tolerances (to assure uniform flow) and to very tight roughness tolerances (to delay transition). The cost of the 10 inch wide existing Mach 3.5 Pilot nozzle has been estimated to be in the area of \$300,000 to \$400,000. This nozzle was machined from stainless steel and then ground to the shape tolerance. Long hours of hand polishing then produced the final nozzle. Cost reductions had to be found to make the quiet-flow nozzles affordable for university research. The drawings for the existing Mach 3.5 pilot tunnel nozzle were very kindly supplied by Dr. Stephen Wilkinson of NASA Langley, so that design and cost comparisons could be made.

These drawings (see LD-527646) tolerance the area near the nozzle throat to what appears to be an absolute accuracy of 0.0003 inches. It seems that this tolerance is the reason why the nozzle was ground to shape, at great expense. This very close absolute accuracy should result in a nozzle flow much more uniform than is usually the case for supersonic wind tunnels. It should be remembered that costs increase at least linearly with reductions in allowable error; a reduction in this absolute tolerance from 0.001 inches to 0.0003 inches probably increases costs by more than a factor of 4. It is felt that this tolerance is not required for boundary layer instability work, since the crucial issue is quiet-flow, not unusually good uniformity. Discussions with Ivan Beckwith led to the judgement that this high tolerance might for university purposes be applied only to the waviness specification, which *does* relate to flow quietness. Even for the waviness specification it can probably be relaxed somewhat. These specifications have been based on Mr. Beckwith's many years of experience. The waviness tolerance is derived from some simple computations following from the waviness data found in [2, Figure 4] and [6, Figure 4].

It thus seems reasonable to relax the absolute accuracy requirements to the 0.001 level of accuracy possible with a quality numerically controlled milling machine, thereby reducing the cost of the nozzles by a factor of perhaps 4. Waviness tolerances should still be below 0.001 inch per inch, and attention

will have to be paid to this when the machining strategy is decided on. However, the largest error in machining will probably be due to a slow gradual variation from end to end caused by misalignment of the milling machine ways. This error should have only a limited effect on the flow. This change in fabrication technique should by itself bring the cost for the nozzle blocks down within budget.

The material of fabrication is also a crucial issue for machining cost. Machining cost for stainless steel is about a factor of 2 more than that for aluminum. However, aluminum does not polish well. Current plans are to fabricate the nozzle from easily machined aluminum and then to nickel plate the nozzle and polish the nickel. This technique has been used to make x-ray optics [3], so there is an extensive literature regarding material selection and machining techniques. These optical researchers often use diamond turning to produce optics with an axis of symmetry; this be a cost-effective way of making an axisymmetric nozzle, since the final surface finish would be directly produced without extra finishing.

As this suggests, the remaining major cost in the fabrication process is the cost of polishing the nozzles to reduce roughness. Usual polishing specifications are given in terms of the root mean square roughness height achieved, which is estimated using various schemes for measuring roughness over sample sections of the workpiece. However, for the quiet tunnels the crucial issue is the maximum roughness height, which is expected to trip the boundary layer locally if it is too large. In a 1986 paper [1] the critical roughness Reynolds number (local Reynolds number evaluated at the roughness height, $R_k = \rho u y / \mu$, where all quantities are evaluated at the roughness height $y = k$) was estimated to be between 12 and 42, and the value of 12 was chosen for design purposes. The acceptable physical heights depend on flow parameters, but result in expensive finishes near the limit of those normally produced. Normal procedures for machined surfaces involve finishing using emery cloth, diamond paste, or other abrasives, which produce a good average finish as the abrasive size is decreased. However, the quiet flow requirement is on the maximum flaw, not on the average finish. Difficulties in controlling the maximum flaw have led to specifications on average finish nearly ten times tighter than the maximum allowable flaw. Automatic methods of measuring the maximum flaw are being sought. Another possibility is to find a surface coating which goes on thin and is dominated by surface tension while wet. This surface tension would act to smooth out the finish.

However, it is difficult to find such a coating, since it cannot run during application and must sustain reasonable amounts of heat and handling.

A sample block has been constructed from aluminum using the Purdue Central Shop numerical mill. The absolute shape of this block was measured at NASA Langley to determine the machining error. The block has since been nickel plated and polished and is to be tested for surface finish quality. It will then be available for trial of various surface finishing methods.

5 The 2 Inch Purdue Supersonic Wind Tunnel: Modifications for Low Reynolds Number Quiet Flow

During the course of the project development, it became clear that there were several issues which could be addressed at very low cost by upgrading the current Purdue 2 inch supersonic wind tunnel. This upgrade would allow development of instrumentation, calibration of instrumentation, and tests of fabrication schemes, at a very low cost. The principal requirement was for a vacuum tank to allow operation of the tunnel at the very low pressures required to achieve quiet flow in an ordinary supersonic wind tunnel test section. However, this vacuum tank could then be used for the Ludwig tube later, as could the associated vacuum pump.

A 500 cubic foot vacuum tank is being procured for this use; processing of this purchase order is nearly complete. A concrete pad to support the tank has been installed, and piping to connect the tank to the wind tunnel test section has been procured. The vacuum pump is also nearing readiness. Twin proposals have been sent to NASA Langley to support development of instrumentation and experiments on receptivity and roughness.

6 Summary

The design has progressed to the point where it seems clear that the budget is feasible. A crucial element is the supersonic nozzle design and this is not yet complete. Sufficient progress has been made on the fabrication technique, however, that it appears that a sufficiently good nozzle can be fabricated for

the funds available.

Progress will be reported on at the November 1990 meeting of the Division of Fluid Dynamics of the American Physical Society in Ithaca, New York.

7 References

- [1] I.E. Beckwith, F.J. Chen, and T.R. Creel. *Design Requirements for the NASA Langley Supersonic Low-Disturbance Wind Tunnel*. Paper 86-0763, AIAA, 1986.
- [2] I.E. Beckwith and W.O. Moore III. *Mean Flow and Noise Measurements in a Mach 3.5 Pilot Quiet Tunnel*. Paper 82-0569, AIAA, 1982.
- [3] S. Bowyer and J. Green. Fabrication, evaluation, and performance of machined metal grazing incidence telescopes. In *Grazing Incidence Optics for Astronomical and Laboratory Applications*, August 1987. SPIE Volume 830. Paper apparently also in *Applied Optics*, volume 27, p. 1414, 1988.
- [4] F.J. Chen and M.R. Malik. *Advanced Mach 3.5 Axisymmetric Quiet Nozzle*. Paper, AIAA, 1990. Presented at the June 1990 Seattle AIAA meeting.
- [5] N.S. Dougherty and D.F. Fisher. *Boundary Layer Transition on a 10-Degree Cone: Wind Tunnel/ Flight Data Correlation*. Paper 80-0154, AIAA, 1980.
- [6] C.R. Fitch. *Flow Quality Improvement at Mach 8 in the VKF 50-Inch Hypersonic Wind Tunnel B*. Technical Report AEDC-TR-66-82, Arnold Engineering Development Center, 1966.
- [7] J.E. Harris and D.K. Blanchard. *Computer Program for Solving Laminar, Transitional, or Turbulent Compressible Boundary-Layer Equations for Two-Dimensional and Axisymmetric Flow*. Technical Report NASA-TM-83207, NASA Technical Memorandum, 1982.
- [8] D.F. Hopkins and D.E. Hill. Effect of small radius of curvature on transonic flow in axisymmetric nozzles. *AIAA Journal*, 4(8):1337-1343, 1966.

- [9] J.A. Johnson and D. Cagliostro. Starting phenomena in a supersonic tube wind tunnel. *AIAA Journal*, 9(1):101–105, 1971.
- [10] P. Krogmann. *An Experimental Study of Boundary Layer Transition on a Slender Cone at Mach 5*. Technical Report CP-224, AGARD, 1977. In ‘Laminar-Turbulent Transition’, a conference held in Copenhagen, Denmark.
- [11] H. Ludwieg. *Tube Wind Tunnel: A Special Type of Blowdown Tunnel*. Report 143, AGARD, 1957.
- [12] L.T. Nelms. *Design of Minimum Length Supersonic Nozzle Contour and Associated Subcontours*. Technical Report AEDC-TR-68-212, Arnold Engineering Development Center, 1968.
- [13] A. Pope and K. Goin. *High-Speed Wind Tunnel Testing*. Wiley, New York, 1965.
- [14] D.A. Russell, G.S. Knoke, and J.C. Wai. Uniformity of Ludwieg tube flows. In *Modern Developments in Shock Tube Research, Proceedings of the 10th International Shock Tube Symposium, Kyoto, 1975*.
- [15] J.C. Sivells. *A Computer Program for the Aerodynamic Design of Axisymmetric and Planar Nozzles for Supersonic and Hypersonic Wind Tunnels*. Technical Report AEDC-TR-78-63, Arnold Engineering Development Center, 1978.
- [16] R.F. Starr and C.J. Schueler. *Experimental Studies of a Ludwieg Tube High Reynolds Number Transonic Tunnel*. Technical Report AEDC-TR-73-168, Arnold Engineering Development Center, 1973.
- [17] F. M. White. *Viscous Fluid Flow*. McGraw-Hill Book Company, New York, 1974.
- [18] J.D. Whitfield, C.J. Schueler, and R.F. Starr. *High Reynolds Number Transonic Wind Tunnels - Blowdown or Ludwieg Tube?* CP 83, AGARD, 1971.
- [19] M.J. Zucrow and J.D. Hoffman. *Gas Dynamics, Volume II: Multidimensional Flow*. Robert Krieger, Malabar, Florida, 1985.