

**COMPLETE THE DEVELOPMENT AND CONSTRUCTION
OF A SPACEBORNE HYDROGEN MASER CLOCK**

NASA-MSFC CONTRACT NAS 8-37752

FINAL REPORT

For the period 11 August 1988 through 31 July 1990

PRINCIPAL INVESTIGATOR

Dr. Robert F.C. Vessot

September 1990

**Prepared for
George C. Marshall Space Flight Center
National Aeronautics and Space Administration
Marshall Space Flight Center, AL 35812**

**by
Smithsonian Institution
Astrophysical Observatory
Cambridge, Massachusetts 02138**

**The Smithsonian Astrophysical Observatory
is a member of the
Harvard-Smithsonian Center for Astrophysics**

The MSFC Technical Officer for this contract is Dr. R Decher

(NASA-CR-184043) COMPLETE THE DEVELOPMENT
AND CONSTRUCTION OF A SPACEBORNE HYDROGEN
MASER CLOCK Final Report, 11 Aug. 1988 - 31
Jul. 1990 (Smithsonian Astrophysical
Observatory) 14 p

N91-13688

Unclas
CSCL 14B G3/35 0319932

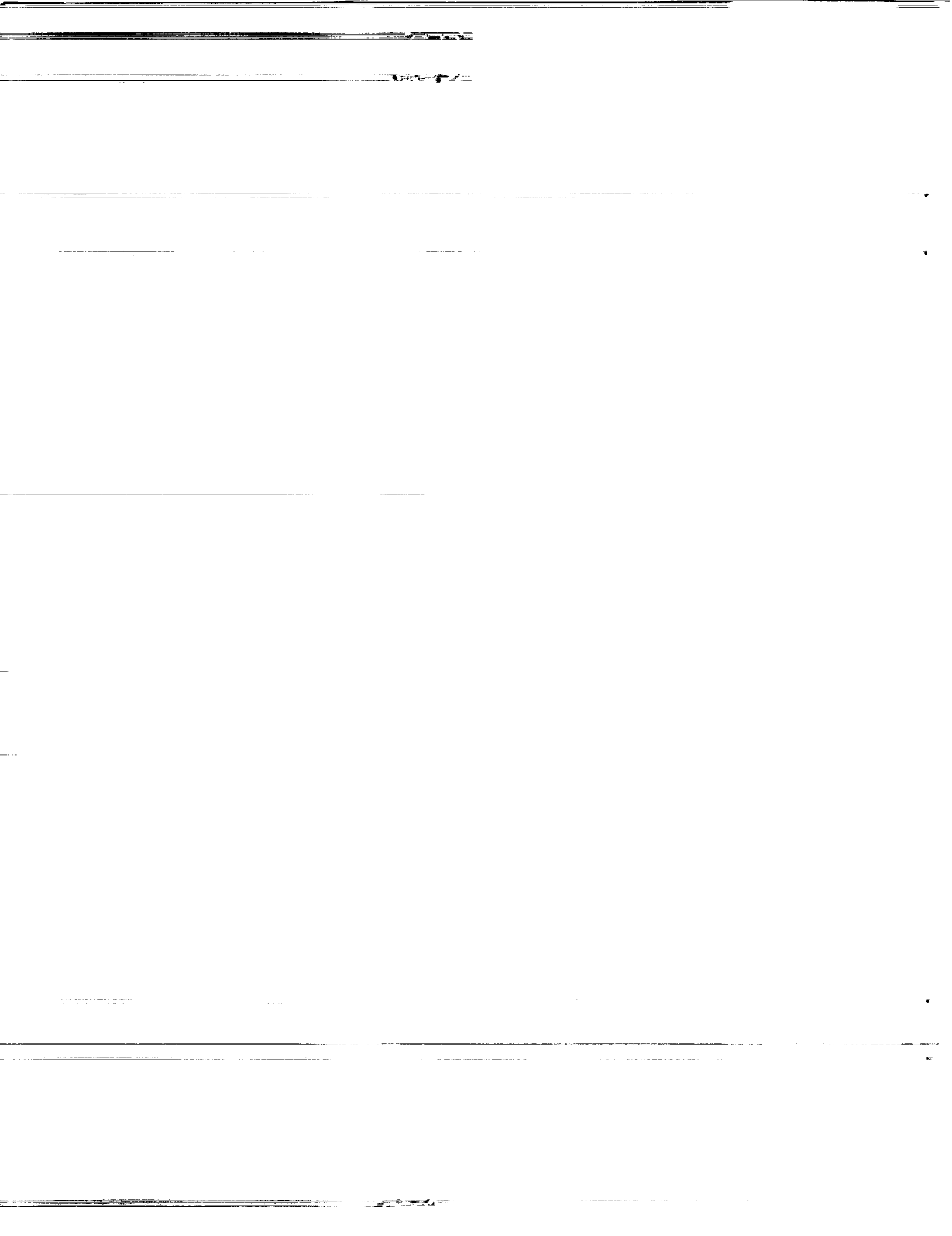

**FINAL TECHNICAL REPORT
NASA CONTRACT NAS 8-37752**

The objective of the work was to complete the development of an engineering model of a spaceborne maser capable of continuous operation for 4 years or longer and to devise an experimental test of the maser in the space environment.

1.0 BACKGROUND OF THE PROGRAM

1.1 The 1976 GP-A Test

The evolution of the space maser began in the late 1960 era and was motivated by the desire to perform a spaceborne test of Einstein's equivalence principle by measuring the predicted gravitational Redshift of a clock moving up and down in the earth's gravity field. With NASA support, an intense period of development began in 1972 and culminated in the 1976 flight of a space maser in a near vertical trajectory to an altitude of 10,000 km. using the Scout solid fueled 4-stage rocket system.

Because of the severe weight constraints and time limitations of the 2-hour trajectory, special technology was developed to maintain the frequency stability in the hydrogen maser clock throughout prelaunch, launch, and until its impact in the ocean. Lifetime of continuous operation was not the main issue, although more than one year of continuous operation was demonstrated during a period of testing. The principal challenges were to maintain structural, and more seriously, thermal stability of the maser throughout the trauma of launch with the 4-Stage Scout Solid Fueled Rocket System. Very little thermal stabilization time was allowed during the flight and the highly desirable capability of using the vacuum of space in conjunction with multilayer insulation was not available. Barometric stress changes from launch to space also produced complications in the design, as did the requirement for cooling the r.f. plasma discharge that was used to dissociate the molecular hydrogen to produce a beam of atomic hydrogen in the maser.

Since 1976, much of the GP-A maser technology found its way into 20 SAO ground-based VLG-11 series masers produced for JPL (for their Deep Space Network), various radioastronomy observatories around the world for the U.S. Naval Research Laboratory (NRL), and for the U.S. Naval Observatory (USNO). During this time, continuation of space maser development was supported by both NASA and NRL. This work was focussed chiefly on the atomic hydrogen dissociator and the thermal control of the maser after thermal stabilization in the vacuum of space. However, until the beginning of the subject contract, no opportunity arose to combine these developments into an engineering model of a space maser.

The planning of conducting a spaceborne test, which is a requirement for continuing the present program of development of space maser flight hardware, will depend on the type of vehicle that could become available. The philosophy of the present contract was, and continues to be, to design a hydrogen maser clock system suitable for a wide spectrum of space applications, such as a lunar base, the space station, earth orbiters, and deep space probes.

1.2 Status at the Outset of the Program

Maser components from GP-A and other development work supported both by NRL and NASA were on hand at SAO, and it was possible to complete the engineering model with the \$120K funding available under the subject contract. These components were 1) the cavity-bulb assembly and supporting hardware, 2) the Hexapole magnet, and 3) some glassware suitable for the r.f. dissociator to produce atomic hydrogen. These components were made available to the program by NRL and SAO.

2.0 PROGRESS OF THE PROGRAM - 1988-1990

2.1 Magnetic and Thermal Control

Work began late in 1988 and a layout of the new maser was completed by February, 1989. Detail drawings that enabled procurement of hardware were completed in March of 1989. At the outset we recognized that, in contrast to the 1970's era, vendors that we approached were not eager to consider doing such small scale work in that they were well occupied with other work during these

economically booming times. A particularly difficult situation arose in the magnetic shielding procurement and that of the two-layer printed circuit solenoid because of its large dimensions. This was resolved by specially procuring the circuit material and finding a local company that was willing to take the job on an experimental basis using silk screening techniques for replicating the circuit structure.

The thermal design of the maser was predicated on being able to operate it with a reasonable degree of thermal stability in air to permit testing prior to its subsequent operation in space. The thermistor sensors, marked T, and heater locations are shown in Figure 1, which is a layout of the space maser. A first cut at the thermal design was made by numerical computation and the requirements for heater resistances in the 7 temperature-controlled zones were established. A computer model of the space maser indicated that thermal properties in air and under vacuum would be as shown in Table I.

The most important requirement in the thermal control of the maser is to avoid changes in temperature with time. Small time-invariant temperature gradients, however, can be tolerated. We have used 7 zones of control. Three of these are on the inner vacuum tank, one at each end and on the cylindrical body of the tank. As shown in Figure 1, the tank is mechanically supported by two tubular necks, one attached to the baseplate, the other to an outer cylindrical structure that is attached to the outer edge of the baseplate. Between the outer structure and the tank are 4 layers of magnetic shielding supported by rings that take up the spaces between the corners of shields and the corners of the tank and the outer structure. The spaces between the shields are insulated with multi-layer reflective insulation (MLRI).

Under vacuum conditions the MLRI is extremely effective and the principal heat conducting paths to the tank are the two necks and the magnetic shield supporting rings. In air the MLRI is much less effective, and there is considerable heat flow through the areas that it encloses.

A temperature-controlled surface located at the ends of the cylinder is connected thermally to the necks at places where a heat station would be required under vacuum conditions. The entire area of the ends of the assembly can thus be

TABLE I

	CONTROL ZONE	MEASURED POWER AT 25C IN AIR (WATTS)	CALCULATED POWER AT 20C	
			IN AIR (WATTS)	IN VACUUM (WATTS)
1.	TANK DOME	1.60	1.60	1.05
2.	TANK BASE	1.57	1.60	1.05
3.	TANK CYLINDER	5.83	5.15	1.32
4.	OVEN DOME	0.62	1.83	1.42
5.	OVEN CYLINDER FWD	3.76	7.1	0.61
6.	OVEN CYLINDER AFT	4.17	7.1	0.61
7.	OVEN BASE	0.45	1.83	1.42

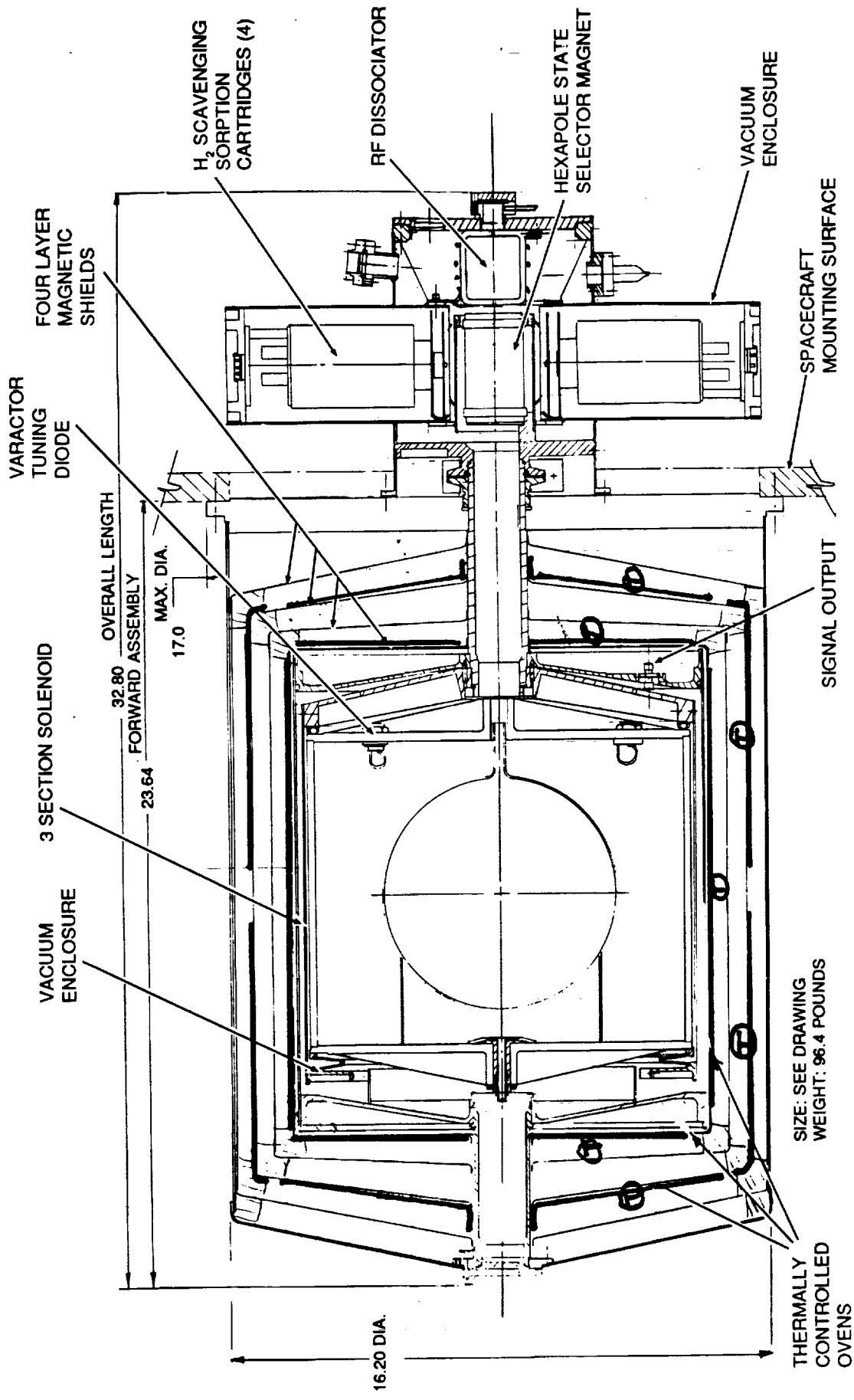

SPACE MASER DESIGN CONCEPT

Figure 1 Thermal Design

temperature controlled along with the neck under atmospheric conditions when the heat load through the area is greater than through the neck. Under vacuum conditions the heat load through the end surface area is insignificant compared to that of the neck so that the neck is controlled by its thermal connection to the temperature controlled surface plate. Similarly, the area of the cylindrical section is controlled by two separate zones that include the conduction paths through the magnetic shield support rings.

2.2 Mechanical

Figure 2 shows the vacuum manifold with the four sorption pump enclosures located below the main mounting plate. The cavity resonator is shown above the plate inside the structure that holds the cavity cylinder and its ends in compression as shown by the heavy lines in Figure 3. The cavity, shown dotted, is held in compression by a double Belleville spring at its left hand end and rests on 12 rollers, shown at its right hand end. It is enclosed by the vacuum tank shown cross hatched which is supported in cantilever to the mounting plate at the right. This cavity mounting structure prevents changes in barometric deformation of the vacuum tank from stressing the cavity structure. Changes of axial stress in the cavity, owing to the differences in the thermal coefficient of expansion of Cer-vit and the surrounding aluminum structure, are attenuated by the zero-rate spring and by the radial compliance of the rollers. This mounting system for stress relief of the cavity was used for the GP-A experiment.

To avoid having spurious magnetic fields at the storage bulb, the vacuum enclosure inside the magnetic shields is made of titanium alloy (6AL-4V). The structure outside the shields is made of stainless steel. All vacuum joints are metallic, no elastomer seals are used.

Four sorption cartridges to scavenge hydrogen are located in a cruciform array symmetrically about the axis of the maser. A small appendage ion pump is used to cope with non-hydrogen gases, such as CO, CO₂, that can evolve from the system. The r.f. dissociator, located entirely within the vacuum envelope, consists of a glass vessel that is thermally connected to the outer surface. About 5 watts of 65 mHz r.f. excitation power is required and is readily dissipated to the outside of the vacuum structure by conduction.

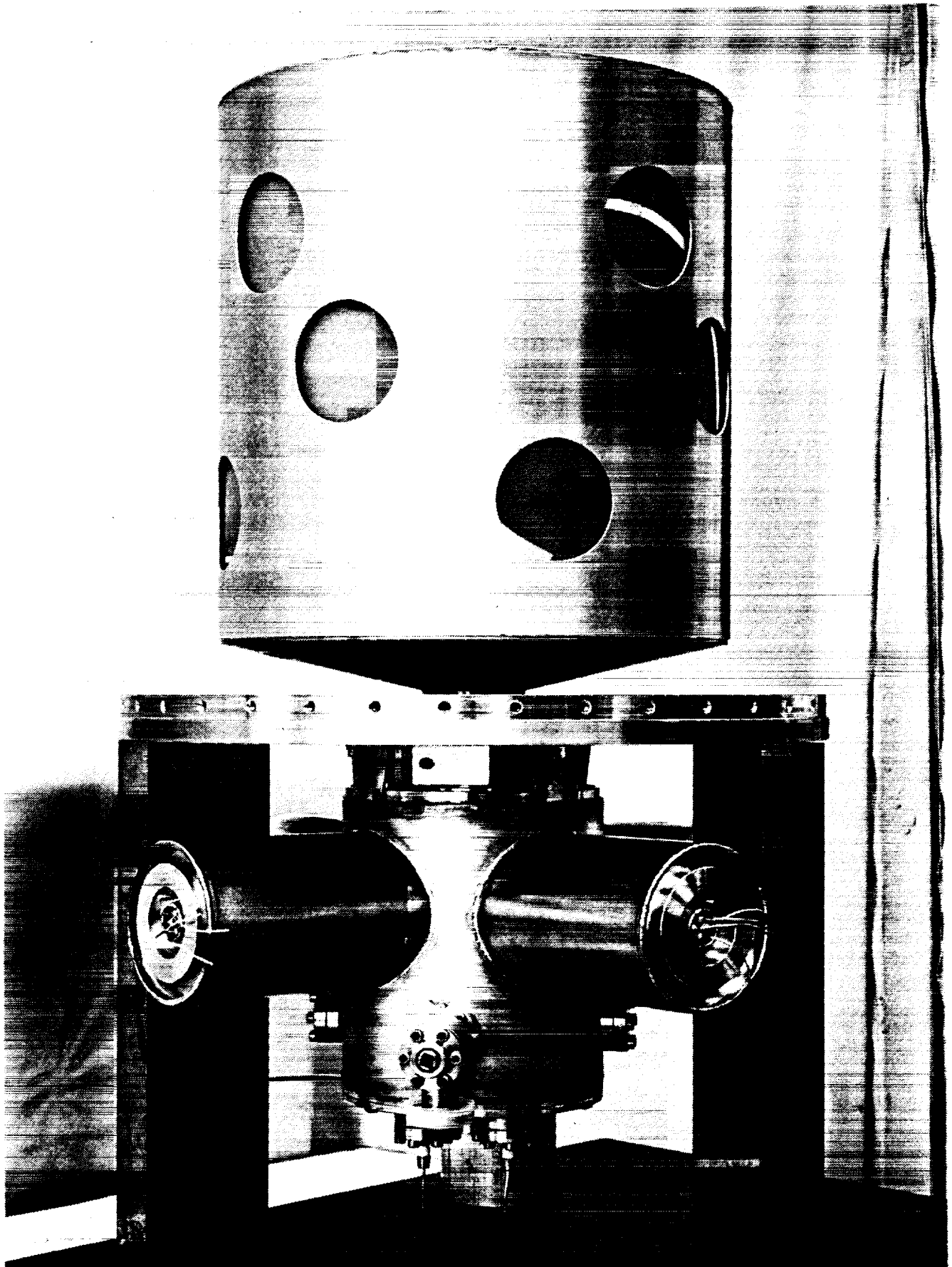
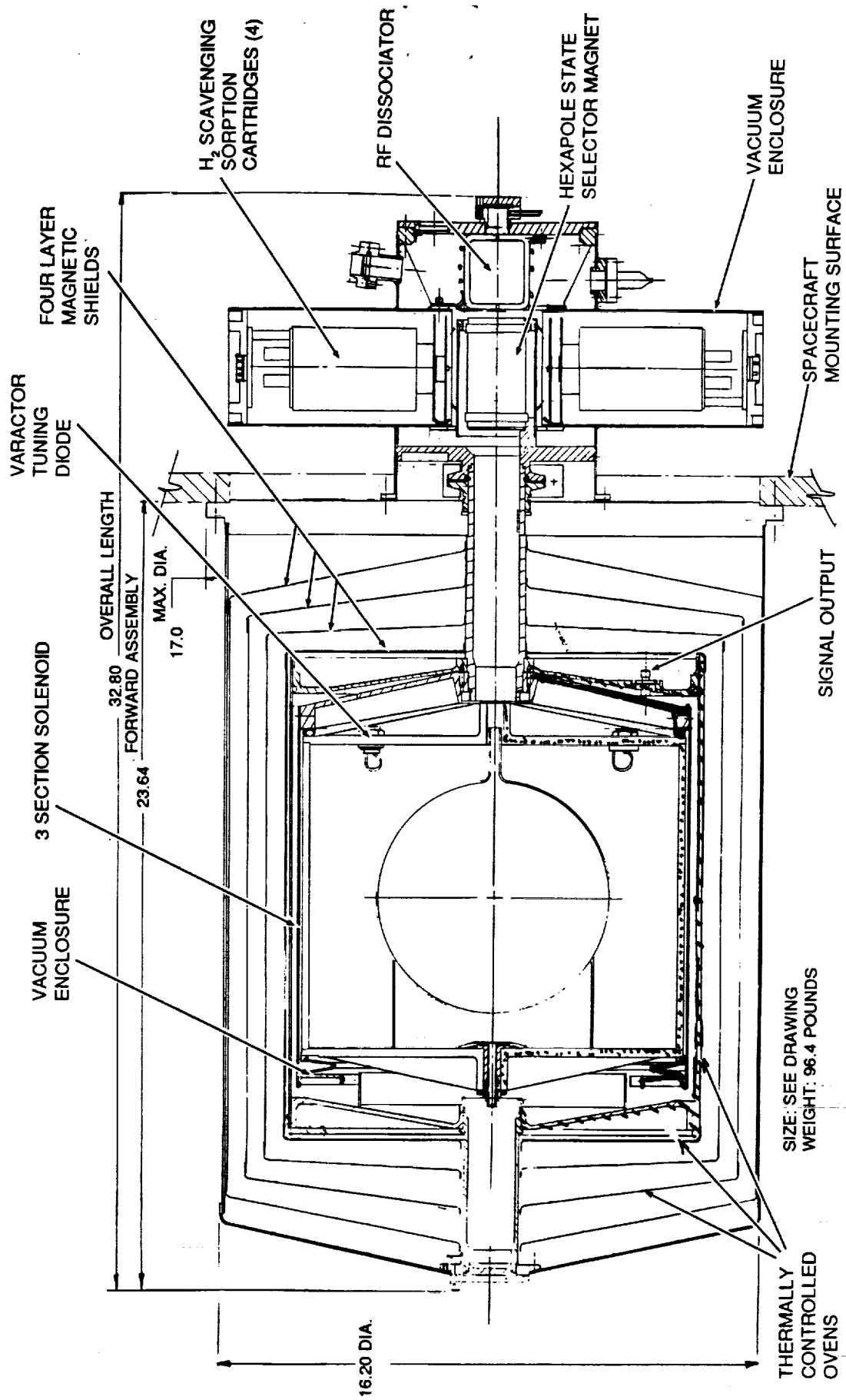

Figure 2 Vacuum Manifold with Sorption Pump Enclosures
(Lower half of photo)



SPACE MASER DESIGN CONCEPT

Figure 3 Cavity Assembly

The basic structure is about 16" dia. (406 mm), 32.8" (83 mm) long and will weigh about 96 lbs. (44 kg) once the heavy members are properly light-weighted by removing excess metal. The completed engineer model is shown in Figure 4.

2.3 Tests and Modifications

On 30 March, the vacuum system of the maser was closed and evacuated. Only two of the four cartridges were installed so that we could accelerate the life test by a factor of two and by doubling the beam flux, accelerate the test by another factor of two. By running the maser for one year under the above condition, we should be able to gain some confidence that it will operate for four years at normal flux with its full complement of sorption cartridges.

After the usual helium leak checking procedures and some revision of the temporary indium seals used temporarily in the place of the permanent gold seals, we were able to oscillate the maser for the first time. We found that the magnetic shields were extremely ineffective; we measured a shielding factor, S , defined as $\Delta B_{\text{outside}} / \Delta B_{\text{inside}}$ which was disastrously poor, having a value of 550 instead of a value of 20,000 that we anticipated from the four layers of 0.014" well annealed moly-permalloy magnetic shielding.

We took the maser apart, removed the 4 layers of magnetic shields and sent them to a nearby magnetic shielding manufacturer for hydrogen annealing according to a time vs. temperature schedule that we specified. When they were removed from the hydrogen furnace we handled them very carefully to avoid deforming the thin and now very soft moly-permalloy. The shields were tested in the lab before being reassembled in the maser. The shielding factor for the nested 4 layer array was measured to be 32,500, -- considerably better than expected.

After assembly we remeasured the shielding factor and found it had dropped to about 7,000. It is clear that our method of assembly has stressed the very thin shields. In the future we may have to use a thicker material and be more careful in fitting the metal shields to the mounting hardware.

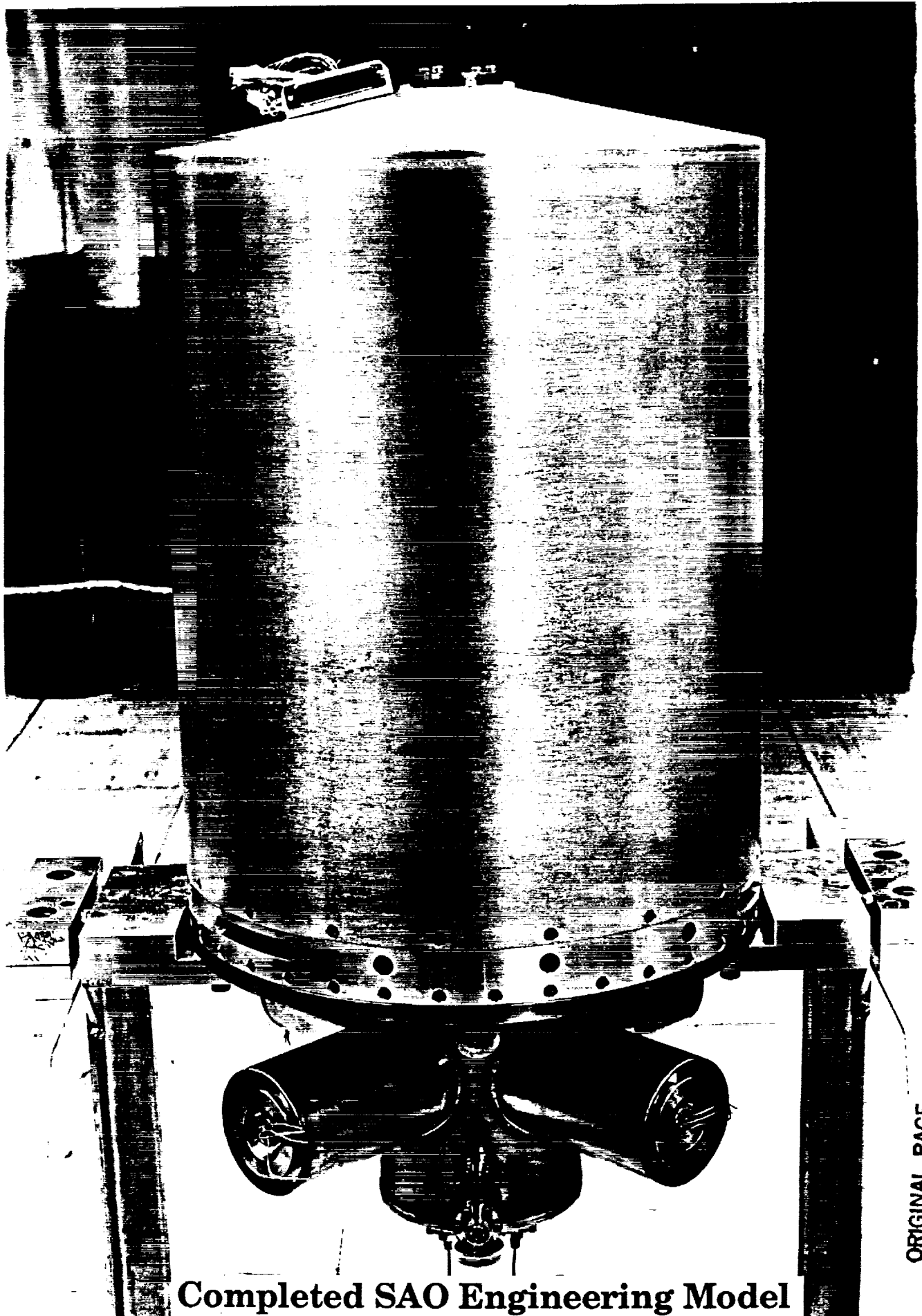

Figure 4

**Completed SAO Engineering Model
Space Maser Ready for Test**

ORIGINAL PAGE
BLACK AND WHITE PHOTOGRAPH

3.0 RESULTS OF TESTS

We made measurements of the maser's parameters in the first week of June 1990 using a well-calibrated hydrogen maser receiver to measure output power with 0.2 dB resolution. We calibrated the cavity resonator tuning system. This calibration enabled us to determine the oscillating line Q of the maser by measuring the shift in maser output frequency resulting from known resonator frequency variations.

From the line Q data measured at different levels of maser oscillation we can determine the two maser oscillation parameters q and γ . The q parameter is related to the efficiency of state selection and the general design of the storage bulb-resonator combination. The γ parameter is a measure of the relaxation processes the atoms undergo while stored in the storage bulb, including their rate of escape from the bulb.

We measured q and γ at two levels of internal magnetic field. The results are as follows:

Field	γ (sec ⁻¹)	q
High	1.93	0.15
Low	2.2	0.13

We conclude that the state selection in the maser is operating normally and that the small increase in relaxation rate, γ , from high to low magnetic fields is due to small residual magnetic inhomogeneities.

The results are very good and the maser has been operating reliably throughout the tests. The maser's external electronic control systems have been consolidated into one cabinet and the maser has been set up to operate continuously. The maser output signal level and ion pump current are being continuously monitored with a strip-chart recorder. As of September 9, 1990, when this report was completed, all systems are "go", and life-testing of the maser is now in progress.

4.0 CONCLUSION

On 19 June 1980, we were happy to learn that the space maser program will be continued by NASA under the management of the Marshall Space Flight Center. The project is off to a good start and we look forward to continuing the development and the construction of a maser to be tested in space.

ABSTRACT

Our objective, "to complete the development of an engineering model of a spaceborne hydrogen maser," was successfully achieved. A layout of the maser and detail drawings of the physics package were completed during the first 7 months of the contract. A computer model was made for the maser's thermal design. Using numerical computations, heater resistances were established for 7 temperature controlled zones. The physics package includes: a vacuum manifold that houses four sorption pumps capable of scavenging hydrogen for 4 years; a titanium vacuum tank housing the cavity, metallic seals for all vacuum joints, an r.f. dissociator within the vacuum envelope, a two-layer printed circuit solenoid and four layers of moly-permalloy magnetic shields. Problems were encountered and overcome in the procurements of the PC solenoid and the magnetic shields. After completion of the fabrication of the maser's components, the maser was assembled using these parts and other components made available by SAO, NRL and NASA from earlier development work. In March, 1990, the vacuum system was assembled, and by May the maser assembly was completed. The magnetic shielding was poor and the shields were removed, reannealed by a local vendor, and the maser was reassembled. The maser began tests in early June and has been oscillating since that time. The test results of the maser are very good and we are now conducting a life test of the maser as of this report (early September 1990). We anticipate continuing the development and construction of a maser to be tested in space under a new contract from NASA's Marshall Space Flight Center. ~~will continue.~~



Report Documentation Page

1. Report No.		2. Government Accession No.		3. Recipient's Catalog No.	
4. Title and Subtitle "Complete the Development and Construction of a Spaceborne Hydrogen Maser Clock"				5. Report Date 14 September 1990	
7. Author(s) Dr. Robert F.C. Vessot				6. Performing Organization Code	
				8. Performing Organization Report No.	
9. Performing Organization Name and Address Smithsonian Institution Astrophysical Observatory 60 Garden Street Cambridge, MA 02138				10. Work Unit No.	
12. Sponsoring Agency Name and Address George C. Marshall Space Flight Center National Aeronautics and Space Administration Marshall Space Flight Center, AL 35812				11. Contract or Grant No. 506-48-41	
				13. Type of Report and Period Covered Final Report 11 Aug. 1988 - 31 July 1990	
				14. Sponsoring Agency Code AP-29-D	
15. Supplementary Notes COTR, Dr. Rudolph Decher					
16. Abstract See attached abstract.					
17. Key Words (Suggested by Author(s)) Prototype Space Hydrogen Maser Clock			18. Distribution Statement Unclassified Unlimited		
19. Security Classif. (of this report) Unclassified		20. Security Classif. (of this page) Unclassified		21. No. of pages 14	22. Price