

NASA Conference Publication 10055

Exobiology on Mars

(NASA-CP-10055) EXOBIOLOGY ON MARS (NASA)
35 p C5CL 06C

N91-15691

Unclas
G3/55 0325585

*Report of the workshop "Exobiology Instrument
Concepts for a Soviet Mars 94/96 Mission"
held at NASA Ames Research Center
Moffett Field, California
February 27-28, 1989*



Exobiology on Mars

Edited by
D. L. DeVincenzi, J. R. Marshall, and D. Andersen
NASA Ames Research Center
Moffett Field, California

*Report of the workshop "Exobiology Instrument
Concepts for a Soviet Mars 94/96 Mission"
held at NASA Ames Research Center*
Moffett Field, California
February 27-28, 1989

NASA

National Aeronautics and
Space Administration

Ames Research Center
Moffett Field, California 94035-1000
1990



PREFACE

Mars has long fascinated exobiologists. Of all the planets in the solar system aside from Earth, Mars holds the most promise for unlocking the secrets of the origin and evolution of life. Indeed, Mars may contain ancient clues to the origin of life that are unavailable on the more dynamic Earth. In legend, Mars has long been associated with life; someday, the planet may reveal whether that association has a foundation in reality.

Programs of Mars exploration were begun by the United States and the Soviet Union during the 1960s, and continued in the 1970s. The missions conducted by the United States anchored the foundations of Mars planetology and culminated for exobiologists in the Viking search for life on the surface of Mars. Although this extraordinary pursuit added much to our knowledge of the planet, the Viking lander experiments seemed to rule out organic life on the surface. However, the orbiter images from both Viking and Mariner offered a glimpse of an earlier Mars that may have been more hospitable to life as we know it.

We may again be embarking on a course that will lead to more extensive exobiological investigations of Mars. The Soviet Union's Phobos missions initiated an extensive program of Mars exploration that includes an additional mission or set of missions in 1994 and 1996 and culminates in a Mars Rover and Sample Return mission as early as 1998. The United States has also scheduled a Mars launch with the Mars Observer in 1992, and a Mars Rover and Sample Return mission is under extensive study for a potential launch by the turn of the century. Human missions to Mars are also under study in the United States, with the exobiological study of Mars a prime science goal.

Perhaps the most encouraging note in this renewed emphasis on Mars is the unfolding international cooperation. U.S., Soviet, and European scientists are cooperating on mission studies, landing-site selection, and, of course, planning for exobiology studies of Mars. This workshop report presents investigations that may be proposed for missions within both the U.S. and Soviet programs. As such, it will help mission planners in all participating nations understand the nature of the instrumentation associated with exobiological investigations to be conducted on Mars.

John D. Rummel, Ph.D.
Program Manager,
Exobiology
NASA Headquarters
Washington, DC
August 1989

TABLE OF CONTENTS

	Page
PREFACE	iii
ABSTRACT	vii
INTRODUCTION	1
INSTRUMENT CONCEPTS.....	3
THE USE OF NEUTRON SCATTERING FOR THE DETECTION OF WATER AND ORGANICS ON THE SURFACE OF MARS.....	3
<i>B. Clark, W. Gardner, and A. Seiff</i>	
SPECIFIC-ELECTRODE MEASUREMENT OF CHEMICAL PROPERTIES OF THE MARTIAN SOIL	5
<i>B. Clark, S. Chang, and J. Oro</i>	
SURVEY OF OXIDANTS IN THE MARS NEAR-SURFACE LAYER	9
<i>C. Stoker, A. Seiff, H. P. Klein, C. McKay, and R. Day</i>	
THE ANALYSIS OF MARTIAN SOIL VOLATILES USING A THERMAL PROCESSOR/EVOLVED GAS ANALYZER	15
<i>G. Carle, R. Mancinelli, and R. Wharton</i>	
THE DETECTION OF ORGANICS AND VOLATILES WITH MASS SPECTROMETRY	17
<i>A. Nier, J. Oro, D. Des Marais, and D. Rushneck</i>	
BIOLOGICAL PATTERN RECOGNITION IN MARS IMAGING.....	23
<i>E. I. Friedmann and D. Schwartz-Kolyer</i>	
INFRARED LASER SPECTROMETER FOR <i>IN SITU</i> SENSING OF THE MARTIAN ATMOSPHERE.....	25
<i>C. Webster, T. Owen, and D. Hunten</i>	
THE DETECTION OF ANAEROBIC CHEMOAUTOTROPHS ON MARS	27
<i>C. McKay</i>	
SUMMARY AND RECOMMENDATIONS.....	29
WORKSHOP PARTICIPANTS	31
ADDITIONAL CONTRIBUTORS	32

LIST OF FIGURES

	Page
Figure 1 Neutron spectrometer	5
Figure 2 Chemical properties of Martian soil.....	9
Figure 3 Soil-oxidant survey instrument	13
Figure 4 <i>In situ</i> alternative to oxidant survey instrument.....	14
Figure 5 Schematic of differential thermal analyzer/gas chromatograph (DTA/GC)	17
Figure 6 Mass spectrometer using Mattauch Herzog geometry	21
Figure 7 Schematic of complete mass spectrometer analytical system.....	21

ABSTRACT

This report contains descriptions of several instrument concepts that were generated during a workshop titled "Exobiology Instrument Concepts for a Soviet Mars 94/96 Mission" held at NASA Ames Research Center on February 27-28, 1989. The objective of the workshop was to define and describe instrument concepts for exobiology and related science that would be compatible with the mission types under discussion for the 1994 and 1996 Soviet Mars missions. Experiments that use existing technology were emphasized. The concepts discussed could also be used on U.S. missions that follow Mars Observer.



INTRODUCTION

The workshop "Exobiology Instrument Concepts for a Soviet Mars 94/96 Mission" was held at the National Aeronautics and Space Administration (NASA) Ames Research Center, Moffett Field, California, on February 27-28, 1989. It was conducted at the request of Dr. Geoffrey A. Briggs, Director, Solar System Exploration Division, and Dr. John D. Rummel, Program Manager, Exobiology, Life Sciences Division.

The objective of the workshop was to define and describe instrument concepts for exobiology and related science that would be compatible with the mission types under discussion for the 1994 and 1996 Soviet Mars missions. Experiments were emphasized that use existing technology, primarily Viking or Viking derived. The concepts discussed could also be used on U.S. missions that follow Mars Observer.

While final decisions have not been made about the spacecraft to be used for the Soviet 94/96 opportunity, some potential specifications have been given. Included are the following: orbiters with approximate science payloads of 200 kg and data links of 64 kbytes/sec; balloons with 10- to 15-day lifetimes and approximate science payloads of 5 to 6 kg divided between the gondolas and the draglines (or "snake tails"), which would come into contact with the Martian surface during the cooler hours of darkness; penetrators that could last 2 to 3 days (or up to 6 months if radionuclide power sources are used) and that would have science payloads of approximately 2 to 3 kg; small instrument packages or "eggs" that would be deposited onto the Martian surface and that are largely undefined but are expected to have maximum payloads of 3 kg; and landers and rovers that could provide larger instrument platforms.

Participants in this workshop evaluated the scientific opportunities offered by the potential mission vehicles in light of post-Viking knowledge about Mars. They then developed specific instrument concepts tailored to specific vehicles. These concepts were discussed at the workshop, and participants provided suggestions for implementation. The product of the workshop, a set of potential exobiology experiments for the Soviet Mars 94/96 opportunity, is described herein.

Following the workshop, two additional experimental concepts were identified; they are also included in this report. The first of these describes the use of an infrared laser spectrometer for *in situ* measurements of the Martian atmosphere, and the second describes a method for life detection. Both concepts address questions important to exobiological science objectives on Mars, and both are compatible with the mission probes highlighted in the workshop.

As indicated in "Summary and Recommendations," exobiology science objectives for Mars exploration were not extensively discussed at the workshop and, therefore, are not described in detail in this report. Participants were assumed to be familiar with the importance of developing experiment concepts that would shed light on questions of chemical evolution and extant or extinct life on Mars. If more detailed information on the rationale and strategy for exobiological investigation of Mars is desired, the reader is referred to other documents (e.g., C.P. McKay and C.R. Stoker, *The Early Environment and its Evolution on Mars: Implications for Life*, *Reviews of Geophysics*, 27 (2), 189-214, 1989).

A comprehensive description of all important exobiological experiments for all classes of Mars spacecraft was well beyond the scope of this workshop. This workshop was restricted to the consideration of experimental concepts that would be compatible with the spacecraft of limited weight, power, and volume that are being considered by the U.S.S.R. for the 94/96 opportunity (and by the U.S. for, for example, the Mars Environmental Survey mission). Participants also limited their considerations to concepts that did not require extensive research and development, and whose technology had been previously described and/or was readily available. Finally, the timing of the workshop was such that extensive development of ideas either before or after the workshop was not possible. This report, therefore, is the product of a rather limited activity. The spontaneity of the discussions and the preliminary nature of some of the concepts are reflected in the somewhat uneven and brief descriptions included here. More complete and rigorous treatment of the concepts would require a significantly expanded design effort.

INSTRUMENT CONCEPTS

THE USE OF NEUTRON SCATTERING FOR THE DETECTION OF WATER AND ORGANICS ON THE SURFACE OF MARS

B. Clark, W. Gardner, and A. Seiff

Objectives

The objective of this experiment is to detect water and organic molecules on or just beneath the surface of Mars. Knowledge of the amount and distribution of water on Mars is of critical importance to an assessment of many physical and chemical processes that may have been operative at some time in the history of the planet. Additionally, the presence of organic molecules might provide evidence for past or present Martian biota. A neutron-scattering experiment would survey the hydrogen content of the Mars soil, with the range of detection being dependent on the depth of deployment of the detector. A significant signal would indicate the presence and amount of hydrogen, which is most likely associated with water (probably as subsurface ice), but is possibly associated with organic molecules because typical organic compounds are 20 to 50% hydrogen atoms. It is expected that the inventory of water will greatly exceed that of any organic molecules. This measurement, combined with an independent water-detection experiment, could place an upper limit on the quantity of organics in the soil. It is expected that the device would also detect chemically bound hydrogen in clays and other minerals, but independent analyses of the soil composition would allow that signal to be subtracted.

Proposed Instruments

The instrument proposed for this experiment is a neutron spectrometer. The basic unit would consist of a source of fast neutrons (a radioactive pellet) placed in fixed geometry with respect to a slow-neutron detector. Because hydrogen has a large scattering cross section for neutrons, the flux of thermalized (slow) neutrons returned to the detector would reflect the abundance of hydrogen atoms in the soil.

Experimental Protocol

Upon activation, the detector would measure hydrogen concentrations within a range of 1 m from the instrument's deployment position. The required counting time would be short, on the order of minutes. Once deployed, a fixed probe could possibly monitor changes, if any, in hydrogen concentration in the regolith over time. If a long-lived power supply were provided, measurements could be obtained during all Martian seasons, and observed changes in the amounts of water present would clarify the possibility of a Martian hydrological cycle.

Mission Compatibility

The neutron spectrometer could be mounted in a penetrator or a balloon snake tail, as shown in figure 1, in an egg, or on a rover. If mounted on a snake tail or a rover, the instrument could measure the geographic variability of hydrogen and identify the regions of greatest biological interest, i.e., regions high in water and/or organic molecules.

The length of the counting times requires that the instrument be at rest during a measurement cycle. This poses no difficulty for penetrator or egg applications. If the instrument were mounted on a rover, the measurement cycle could perhaps be coordinated with the expected pauses in the rover's movement. For the snake tail, measurements either would require a period of low nocturnal wind, or the results would be average measurements over terrain covered during the cycle.

Evaluation of Current Technology

Instrument weight, power, and data requirements can only be estimated prior to design studies, but the neutron spectrometer probably could be built to weigh less than a few kilograms, with correspondingly modest power and data-rate requirements. The neutron source, detector, and associated electronics could be miniaturized for use on low-payload carriers to be deployed on the Martian surface.

Telemetry of data appears straightforward and no major problems are foreseen with this well-established technology. Development time should be compatible with a 1994 or 1996 mission.

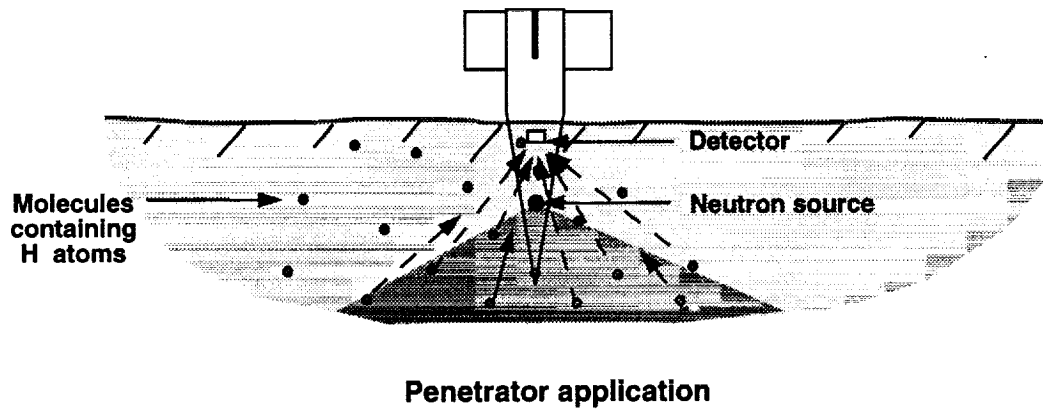
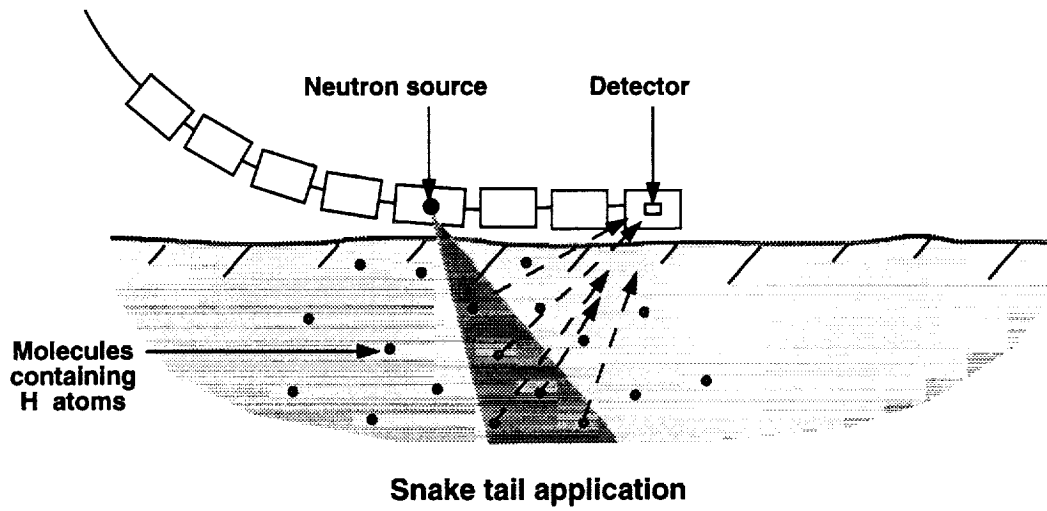

Figure 1. Neutron spectrometer.



SPECIFIC-ELECTRODE MEASUREMENT OF CHEMICAL PROPERTIES OF THE MARTIAN SOIL

B. Clark, S. Chang, and J. Oro

Objectives

The objective of this experiment is to measure a number of important chemical properties of the Martian soil, such as Eh, pH, cations, anions, and oxidant content. These properties would be measured under aqueous conditions in order to determine the abundances and states of the biogenic elements (C, H, N, O, P, S) in the soil, the influence of past aqueous regimes on the weathering of rocks, and the transport of H₂O and other volatiles from depth at any given site. The experiment would also provide insight into chemical hazards to the spacecraft posed by fine-grained, wind-blown dust; potential toxicity, to the crew, of the Martian soil; and *in situ* resource utilization by humans. Preparations for future human missions to Mars must consider these and other environmental constraints.

Proposed Instruments

The basic instrument package (fig. 2) would consist of a wet-soil processor capable of chemical electrode measurements of Eh; pH; anions such as Cl⁻, CO₃²⁻, HCO₃⁻, NO₂⁻, NO₃⁻, SO₄²⁻, PO₄³⁻; and cations such as Ca⁺⁺, Mg⁺⁺, Na⁺, K⁺, Al⁺⁺, Fe⁺⁺, Fe⁺⁺⁺. A particle light-scattering and settling cell for size-distribution measurements would also be included. The actual number of specific electrodes employed on a mission would depend on mission constraints and choices (as yet unmade) regarding the most important of these measurements.

If the instrument were interfaced with a calorimeter/spectrometer, measurements of anions and cations not detectable with electrodes would be possible. To determine cation and anion abundances and identities, the Eh and pH electrodes could be combined with an ion-chromatograph.

If the basic package were joined with an evolved gas analyzer (EGA) (mass spectrometer or gas chromatograph), species such as CO₂, N_xO_y, SO₂, oxidant-O₂, and other volatiles liberated by H₂O and acids could be measured.

Soil-mass measurements could be made by radiation attenuation, volume, or microbalance. Added thermocouples could be used for measurements of the heat of hydration. Elemental analysis of leachates or evaporated residues could be made by the addition of an x-ray fluorescence (XRF) spectrometer.

The basic unit would weigh approximately 2 kg. With the augmentations discussed above, the weight would be approximately 6 kg and the volume would be 500 to 1500 cc, including electronics. Power consumption would be approximately 2 to 4 W (basic unit + EGA or XRF spectrometer), and data output would be 100 bits/sec.

Experimental Protocol

The number of experiments to be conducted would depend on available payload mass and volume and on the variability of the soil at various ranges of sample sizes. This number could be anything from 3 to 21; the latter may be close to the operational limits of the spacecraft (e.g., time or data-transmission constraints). The time required for each experiment would be approximately 3 to 12 hr. Each experiment would require 0.1 to 0.5 cc of sieved soil. After the sample mass is determined, H₂O (or some other suitable liquid) would be added to the soil, and any gases released at that time would be analyzed by the EGA. The electrode properties of the H₂O/soil mixture would then be measured as a function of some predetermined period of time. The leachate would be drained into another vessel, and a similar measure of electrode properties as a function of time would be made of the leachate, in order to determine the composition of soluble ions. The soil sample could then be analyzed by XRF spectroscopy. After the final analysis, the soil sample and leachate would be discharged so that the experiment may be repeated as necessary. Measurements of chemical abundances and properties of the samples would be based on signal intensities. Definitive interpretations would be based on calibration curves for the electrodes.

Mission Compatibility

The experiment and the instruments used could be scaled to suit a range of mission types, from eggs and penetrators to rovers. If flown as part of a penetrator mission, this experiment could be used to characterize possible landing sites for robotic sample-return missions or human exploration.

Evaluation of Current Technology

The wet chemical analysis, XRF spectrometer, and soil-handling capabilities have a strong inheritance from Viking; the EGA, from Viking and Pioneer Venus; and the valves, from the development of Comet Rendezvous/Asteroid Flyby (CRAF) hardware. This instrument package would require gas and liquid valves, mass-measuring devices, liquid reservoirs, a sample-acquisition device, liquid dump lines, solid-waste storage or disposal systems, soil sieves (< 1 mm), liquid feed and purge lines, and possibly a drill sampler if on a penetrator. Minimal technology development would be required, although flight qualification of the existing technology is necessary. Development of electrodes that have the ability to survive high-G loads or to maintain stability over long mission lifetimes would be required.

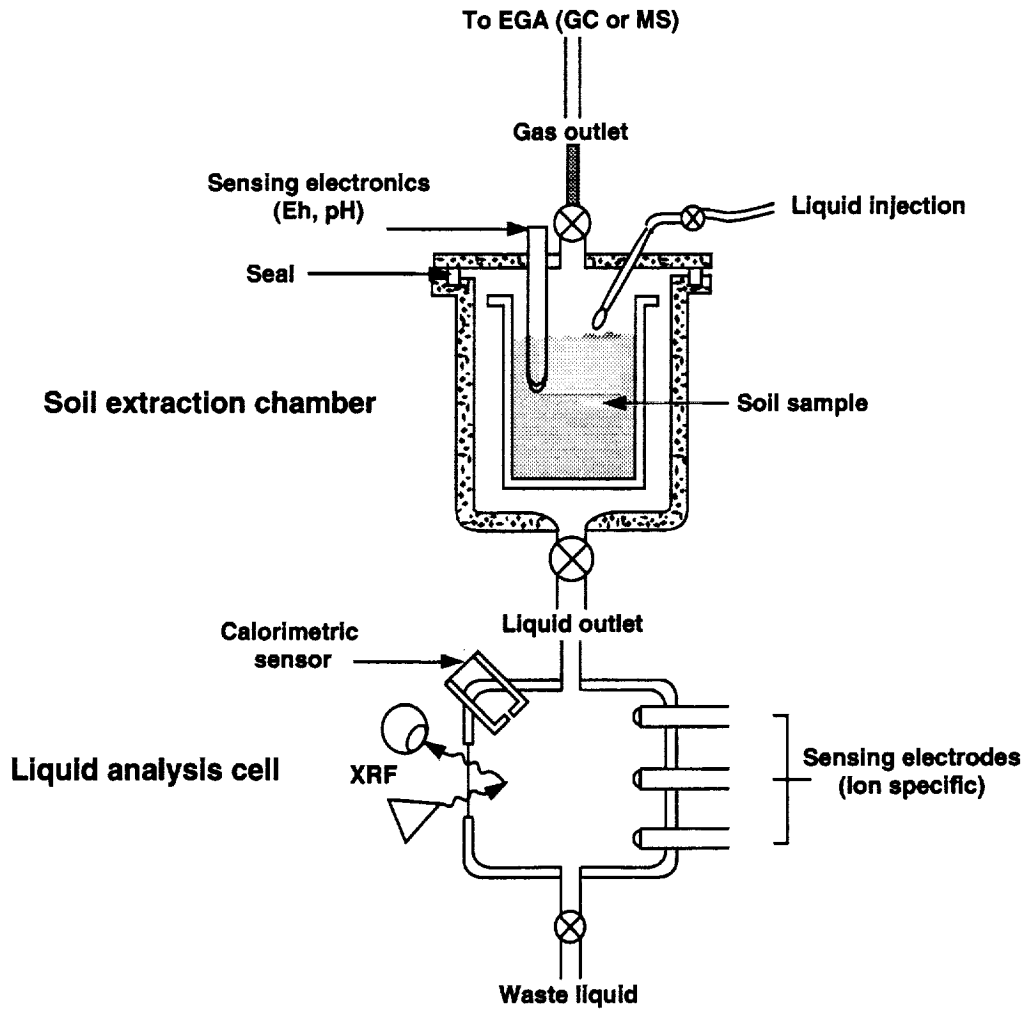

Figure 2. Chemical properties of Martian soil.

SURVEY OF OXIDANTS IN THE MARS NEAR-SURFACE LAYER

C. Stoker, A. Seiff, H. P. Klein, C. McKay, and R. Day

Objectives

One of the most important aspects of this experiment is its relevance to the question of extant life on Mars. The proposed explanation of the Viking Biology Instrument results, particularly the Labeled Release (LR) and Gas Exchange (GEx) experiments, was that they reflected a suite of oxidants in the Martian soil that may have degraded the organics that were added in the experiments. However, the results of the LR experiment were also consistent with biological activity. In the proposed experimental concept, the LR experiment would be reconfigured to distinguish between organic degradation produced by oxidants and that produced by biological activity. The experiment could yield valuable information, whether or not oxidants are found. If the oxidants hypothesized to explain the LR activity were not found, then the case for biological activity would be strengthened. If the distribution of oxidants could be described, it would be possible to determine locations and depths that would avoid oxidants and then to search for evidence of extinct life and/or chemical evolution. Also, future experiments could be designed to detect certain "intractable" organics (e.g., kero-gen) that may be more resistant to degradation.

This experiment could shed light on two major questions raised by the Viking results: 1) Are indigenous organic molecules absent because of their destruction by oxidants? 2) What is the specific nature of the oxidants, and how are they distributed over the planet? It is important to understand if they are everywhere, or if there are specific locations (e.g., polar regions or subsurface) that are free of oxidants. In the absence of direct mineralogical information about oxidants, this experiment emphasizes the effect rather than the composition of the oxidants.

Proposed Instruments

Detectors specific for ^{14}C and O_2 would be used to avoid the complexity and size requirements of a gas chromatograph or mass spectrometer. The instrument would incorporate mechanisms for humidifying or wetting the soil with an aqueous solution, and if sufficient power were available, the instrument would provide heaters to permit comparative measurements of heated and unheated soil samples. This would assist in elucidating the nature of the oxidants. If the instrument had controlled thermal ramping, it would be possible to obtain information on potential peroxides and superoxides by measuring the O_2 evolved versus temperature. Where feasible, the instrument could be combined with a differential thermal analyzer/evolved gas analyzer (DTA/EGA). The estimated volume of the instrument is approximately 0.5 liter. A reasonable estimate for the weight of the identified components is ~1 kg. Diagrams of the soil-oxidant survey instrument can be seen in figures 3 and 4.

Experimental Protocol

The soil could be humidified and then wetted once per sample. The primary measurement would last several hours, but extended release of O₂ could be monitored for several days, if desired. The soil sample size would be approximately 0.5 cc.

A soil sample would be taken into a chamber for analysis at each location in the survey. The analysis may include the following steps: A sample would be heated gradually, while evolved oxygen is detected. The rate of oxygen released as a function of sample temperature would be characteristic of the oxidants present and could be compared with laboratory results to identify the oxidants. A second sample would be humidified while oxygen release is monitored. Oxygen release in the presence of water is a characteristic of candidate oxidants (e.g., superoxide) identified by the Viking experiments. This procedure, used in the Viking GEx Experiment (in which the humidifying agent included nutrients), would verify Viking observations. It would be conducted at multiple locations to determine the variability of oxidant concentrations in the soil. To determine the amount of molecular oxygen that may be adsorbed and stored in interstitial spaces in the Martian soil, an inert fluid would be added to a sample while oxygen release is monitored. Other reagents would be added to the sample. Candidate reagents include well-characterized organics labeled with ¹⁴C, which would be released in gaseous form (as is known from the results of the Viking LR Experiment). Gas (presumably CO₂) containing ¹⁴C would be measured by a ¹⁴C detector. This would reveal the effectiveness of the oxidants in the soil in destroying organic molecules; the time course of the gas released could be used to assay the nature of the process and the quantity of oxidants.

The experiment must be able to examine multiple soil samples at each location. A possible method for doing this, by inserting an open-ended sampling tube into the soil, is shown in figure 4. The sampling tube would include an electrical heater in the tube wall. This may present some problems regarding uniform heating of the soil, but this would be one of the first questions to be addressed during design studies in pre-phase A activities.

Mission Compatibility

The objectives of this experiment could probably be achieved in a sequence of missions, starting with the simplest experiments on the early, low-weight-capacity missions and continuing with more complex experiments carried on subsequent missions with larger payloads. In its simplest form, an instrument of this type would be compatible with balloon snake tails, eggs, and penetrators. More sophisticated instruments using the same basic concepts, perhaps with more reagents and more elaborate thermal analysis, could also be deployed on rovers, which would also offer the opportunity to study the geographical distribution of oxidants.

Evaluation of Current Technology

Existing Viking technology could be used for the pressurization gas supply, isolation valve, solution reservoir, solenoid valve, flow restrictor, and ¹⁴C detector (see fig. 3). The pressurization

gas supply is a small, unregulated volume (not a carrier gas supply). The O₂-specific detector would be a new technology, but several approaches are available. The major technology issue would be the collection (and dumping) of soil samples in a balloon snake or an egg. In the case of the snake, the soil could be collected either by scraping or by the tube-injection system described above.

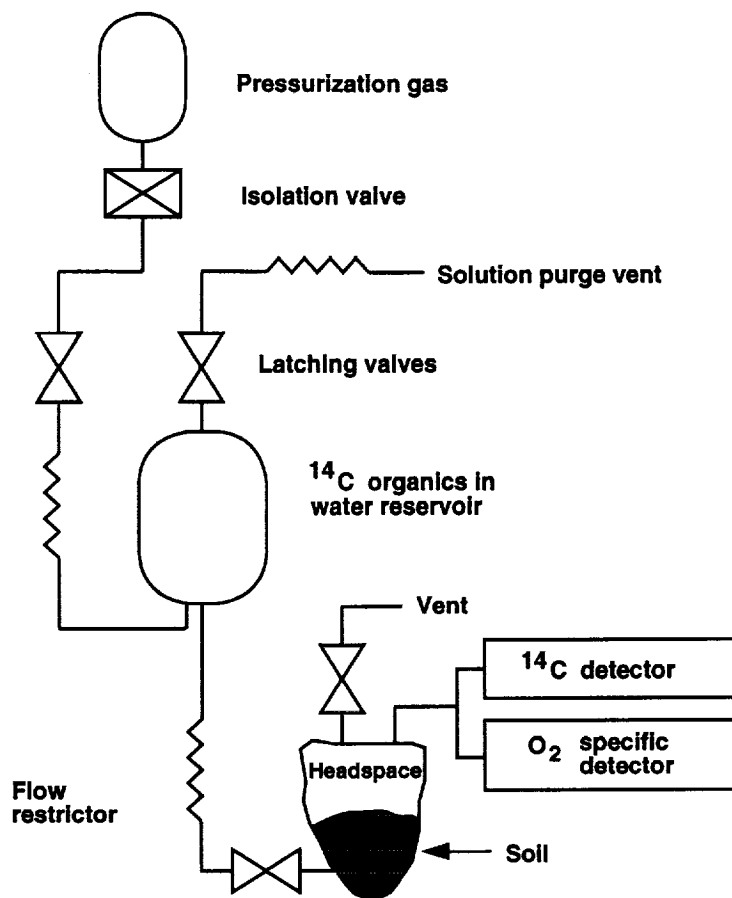

Figure 3. Soil-oxidant survey instrument.

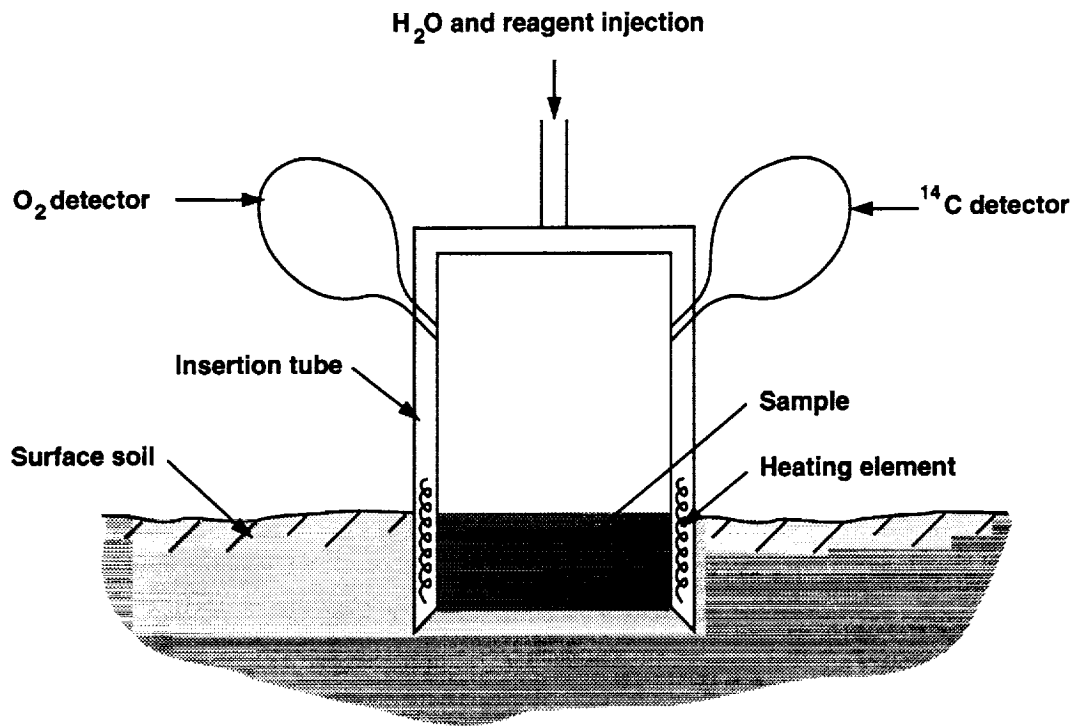

Figure 4. *In situ* alternative to oxidant survey instrument.

THE ANALYSIS OF MARTIAN SOIL VOLATILES USING A THERMAL PROCESSOR/EVOLVED GAS ANALYZER

G. Carle, R. Mancinelli, and R. Wharton

Objectives

The objective of this experiment is to obtain an inventory of the volatiles in the Martian soil. Materials to be searched for include permanent gases, organics, and some evaporites (carbonates, sulfates, nitrates, nitrites, etc.). It is proposed that loose surface materials (soils, aeolian dust, small rocks, and ices) or consolidated materials in sediments and rock outcrops be subjected to thermal analysis.

Coupling a differential thermal analyzer (DTA) with a gas chromatograph (GC) would enable the detection of the physical changes associated with the volatilization of substances; this could provide important mineralogical information. In addition, the instrument would allow the determination of the temperature and possible enthalpy of mineral decomposition reactions in Martian soil, along with the measurement of the amounts of associated evolved gases, as aids in identifying the minerals present. The combination of thermal and effluent gas analysis would help distinguish between phase changes involving water from those involving CO₂ and other volatiles. From the amounts of water vapor evolved from minerals (determined by a GC) and the temperature and heat capacity at which gas evolution occurred (determined by a DTA), soils could be qualitatively characterized as to their clay content and the presence or absence of hydrated minerals that decompose at different temperatures.

Data obtained by the proposed instrument would provide answers to many questions currently surrounding the inventories and chemistry of H₂O, CO₂, CO₃²⁻, N₂, NO_x, H₂S, SO₄²⁻, organic material, and other volatile compounds that may be present on the surface of Mars. The elemental composition of the Martian surface regolith was determined by the Viking landers using x-ray fluorescence and may be a mixture of iron-rich smectite clays (e.g., montmorillonite, scapolite, nontronite), but this is unclear. By analyzing the surface material with an autonomously operating DTA/GC, this identification could be clarified.

Proposed Instruments

Heating of materials, either stepwise or continuously, would occur in a hermetically sealed, heated chamber containing a known volume or weight of Martian surface material. This would be coupled with the monitoring of evolved gases and thermal events (both endothermic and exothermic). A schematic of such a DTA/GC system can be seen in figure 5.

For the proposed thermal analyzers, a range of complexity is available, from simple pyrolysis to differential scanning calorimetry. For near-term Soviet missions, simple pyrolysis may be the most practical. Simple pyrolysis involves the stepwise heating of a sample followed by analysis with an

evolved gas analyzer (EGA). Simple pyrolysis would not provide detailed information about thermal events such as phase changes in the sample being investigated; however, it would offer a less expensive, smaller (volume and mass can be 5 to 10% less than a DTA or DSC), more robust instrument design. For future, less constrained missions, a differential thermal analyzer (DTA) or a differential scanning calorimeter (DSC) would be preferred.

The configuration of the proposed EGA could range from single-compound molecular detectors (e.g., CO₂ electrodes) to complex gas chromatographs and/or mass spectrometers.

Specifications of a simple DTA/EGA (for penetrator application) are: volume, ~2 liters; mass, ~2.5 kg; and power, ~20 W-hr per analysis.

In addition to the above, this instrument would require spacecraft support (for data handling and transmission) as well as a system to obtain samples and transfer them to the instrument.

Experimental Protocol

Heating samples in a stepwise fashion would volatilize adsorbed water and gases (e.g., CO₂ and lower molecular weight organic compounds) first. At progressively higher temperatures, water from mineral dehydration, CO₂ from decomposition of bicarbonates, and volatiles from pyrolysis of higher molecular weight organics would be released. At the highest temperatures, NO_x would be released, as well as additional water and CO₂ from more stable species.

For near-term Soviet missions, the best instrument would be a simple, stepwise thermal-processing chamber that heats material to approximately 700 °C and identifies the gases evolved with a two-column Viking-type gas chromatograph. A sensitive helium-ionization detector, capable of detecting compounds to the picogram level, could be employed to provide a thousandfold increase in sensitivity (this type of detector has been successfully flown on Soviet Venera missions).

Operation of the proposed DTA/EGA would begin with the collection of the sample to be processed by the thermal analyzer. The DTA would begin a standard analysis by heating the reference standard and the sample. When an event such as a phase change occurs, the differential signal would be used to trigger operation of the EGA, which would collect and analyze a sample of gas from the chamber. Use of a highly sensitive pressure transducer able to detect the presence of evolved gas may also be a method of triggering operation of the EGA. Also, gas sampling could be conducted at preset time intervals.

Mission Compatibility

The instrument could be flown on any lander spacecraft (eggs, penetrators, rovers, surface landers) that can accommodate surface-material sampling with a minimum of approximately 20 W-hr of power per analysis. Simple pyrolysis in conjunction with an EGA may be practical for use in eggs or penetrators if sample acquisition and delivery systems are developed. Although there have been design studies for the placement of a DSC/EGA into the body of a comet penetrator, this may prove

too difficult to adapt for near-term missions to Mars. A DTA/EGA or a DSC/EGA could be placed on a larger platform such as a Martian rover.

Evaluation of Current Technology

The instrument concept for the DTA/EGA is based on extensive experience with GC/mass spectrometer (MS) flight experiments and development activities, acquired over the past two decades with projects such as Viking, Pioneer Venus, and Comet Rendezvous/Asteroid Flyby (CRAF). Heritage for the proposed DTA is based on Viking instruments such as the Viking Biology Processor and the GC/MS. The automation of the DTA/EGA system prior to its use on the Martian surface would require additional technology development.

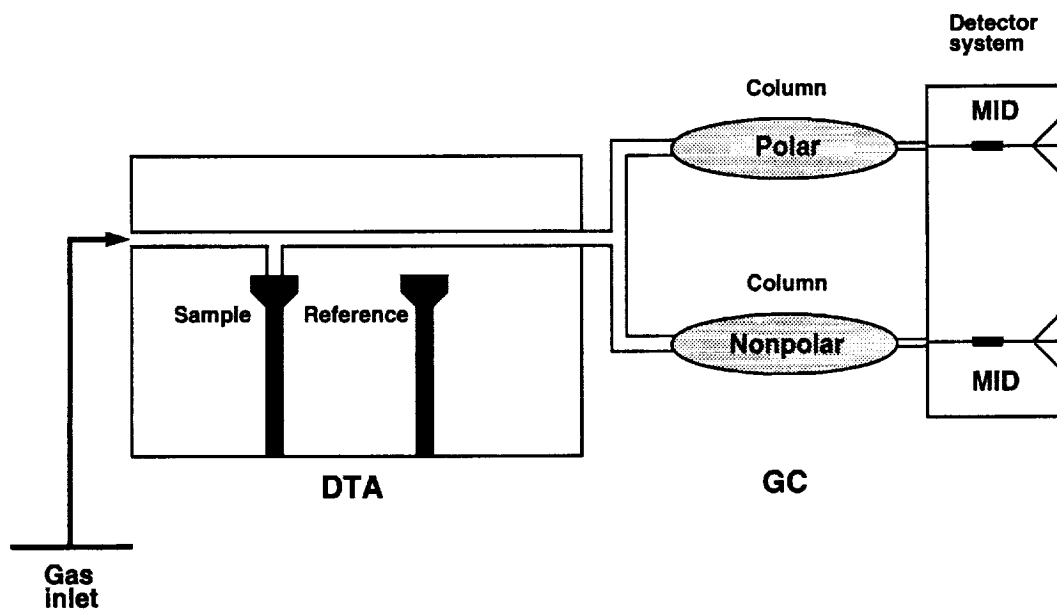

Figure 5. Schematic of differential thermal analyzer/gas chromatograph (DTA/GC).

THE DETECTION OF ORGANICS AND VOLATILES WITH MASS SPECTROMETRY

A. Nier, J. Oro, D. Des Marais, and D. Rushneck

Objectives

Low-mass-range (2 to 150 amu) mass spectrometry would be an excellent method for the analysis and identification of volatile organic and inorganic compounds on the surface or subsurface of Mars. With present technology, a miniature mass spectrometer, about one-half the size of the Viking gas chromatograph/mass spectrometer (GC/MS), would be capable of analyzing organic molecules and other volatile compounds of the biogenic elements (C, H, N, O, P, S).

Information about chemical composition could help determine whether prebiotic chemistry and biological evolution occurred on Mars. If a near-subsurface sample rich in organic matter can be obtained from ancient Martian sediments, and if the molecules in the sample are sufficiently diverse, it may be possible to determine whether the organic molecules were synthesized by abiotic chemical processes or were the result of later biological activity.

If the mass spectrometer were coupled to an appropriate inlet system, this method would also allow the measurement of water vapor, CO₂, SO₂, NO₂, and other volatile forms of the biogenic elements, as well as the determination of their isotopic composition. This in turn would provide information about the mineralogical composition of the Martian surface and of subsurface materials that may be retrieved by drilling or other methods.

The knowledge that may be obtained by this instrument would not only be interesting in terms of understanding past Martian chemical or biological evolutionary processes, but would also enhance understanding of past atmospheric conditions and the occurrence of sedimentation (involving liquid water) and evaporation.

The record of gas compositions and sample-heating behavior would be related to the decomposition of minerals, adsorbed gases, and entrapped organic materials in the samples. Interpretation of this record would likely provide definitive testimony regarding the presence and nature of carbonate and nitrate minerals as well as reduced sulfur, nitrogen, and carbon (organic) compounds. In addition, the stable isotopic compositions of hydrogen, oxygen, carbon, nitrogen, sulfur, etc. could be measured in the evolved gases, perhaps to a precision of a few tenths of a percent. These isotopic measurements could be related to the mineralogical phase changes that released gases during the analysis, providing insights into the origin and history of the phase changes.

Proposed Instruments

Magnetic-deflection and quadrupole mass spectrometers have been used in space-related studies. Weight, volume, and power consumption are roughly the same for the two types of instruments. In general, the magnetic types are more stable and provide higher precision; they are recommended for

the proposed missions. Double-focusing (angle and velocity) magnetic instruments provide higher performance and wider mass range than the single-focusing (angle only) type for the same weight and volume, and have been employed on numerous terrestrial rocket flights; the Atmosphere Explorer C, D, and E satellites; the Viking spacecraft; and the "bus" of the Pioneer Venus mission. A schematic of the instrument (using the Mattauch Herzog geometry) is shown in figures 6 and 7.

A flight mass spectrometer capable of covering the mass range of 2 to 150 amu, including pumps and electronics but not data-storage, would have a volume of approximately 0.02 m³, a weight of the order of 6 kg, and a power consumption of 8 W. Standby power would be only a fraction of a watt.

Experimental Protocol

This instrument would be carried on a rover to multiple sampling sites and, based on estimated spacecraft resources, would perform between 6 and 12 analyses total. Each experiment might require 2 to 4 hr; most of this time would be used for careful, controlled heating of the sample to 700 °C. Sample sizes might range from 500 µg to 5 mg.

In a typical experiment, a sample prepared by crushing and sieving would be introduced into the heating chamber and deposited on the heating stage. The heating chamber would be sealed and evacuated using the attached vacuum pump. During evacuation, the chamber atmosphere, which would include Mars atmosphere plus any gases evolved from the sample, would be analyzed by the mass spectrometer. The pressure of the gas stream to be analyzed would be reduced by a pumping system similar to one already developed for analyses of Earth's upper atmosphere. The sample would then be heated by a differential thermal analyzer (DTA) at a rate sufficiently slow to detect events caused by phase changes and chemical reactions. Any gaseous products of these events would be monitored continuously by the mass spectrometer. The heating and analysis would continue until a temperature of perhaps 600 to 700 °C is attained. At 700 °C, any carbonates present would have decomposed under vacuum. The data would include a record of sample temperature and heating energy as a function of time, synchronized with a continuous time record of mass spectrometric analyses (2 to 150 amu) of the evolved gases.

Mission Compatibility

The weight and power requirements of mass spectrometers are likely to exceed the capabilities of eggs, penetrators, or balloons. Therefore, landers or rovers would provide the best surface platforms from which to operate these instruments.

Evaluation of Current Technology

Together with the abundant information that could be obtained by heating samples, the chief value of this instrument would be its great sensitivity and broad applicability to the identification and isotopic measurements of gases evolved from a heated sample. The instrument has a heritage from previously constructed mass spectrometers, ovens, sample-handling systems, etc., on Viking and

Pioneer Venus. No major new technology would be required for the construction of a flight-qualified mass spectrometer, and no other instrument would match the mass spectrometer's ability to identify gases unequivocally and measure their isotopic composition.

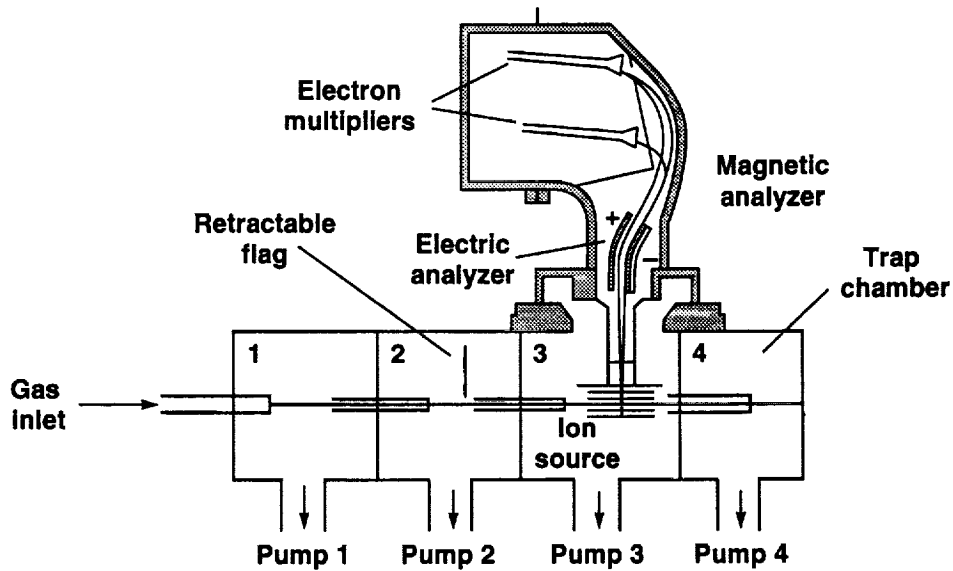

Figure 6. Mass spectrometer using Mattauch Herzog geometry.

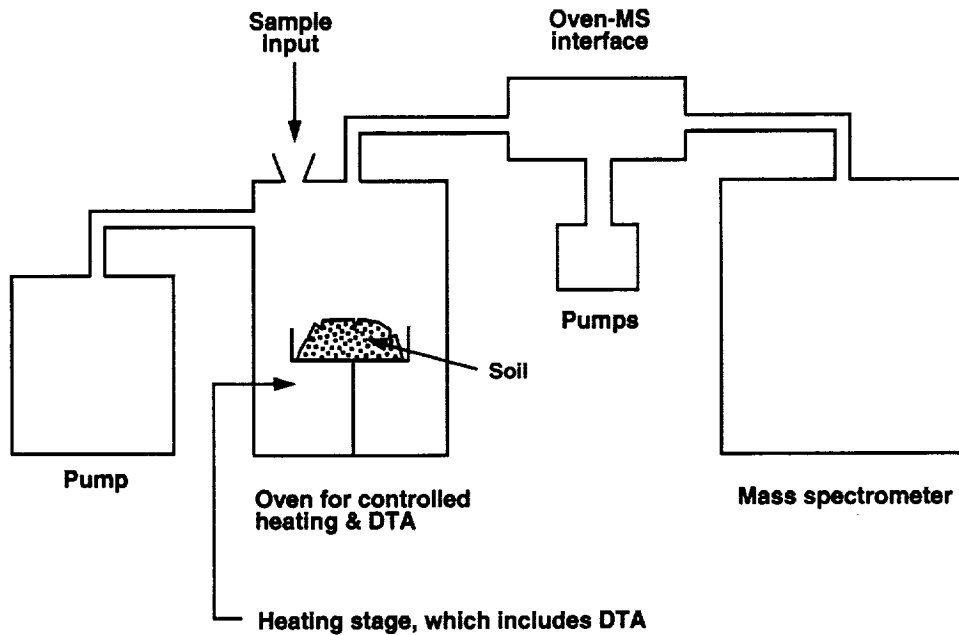

Figure 7. Schematic of complete mass spectrometer analytical system.

BIOLOGICAL PATTERN RECOGNITION IN MARS IMAGING

E. I. Friedmann and D. Schwartz-Kolyer

Objectives

The objective of this experiment is to detect evidence of a Martian biota, extinct or extant. The experiment concept is based on the observation that endolithic microorganisms on Earth (in desert ecosystems in Antarctica and other areas) produce variegated (mosaic) patterns on rock surfaces that are distinguishable from nonbiogenic patterns. An extended area of the Martian surface could be surveyed using the imaging systems on surface-deployed vehicles to identify possible sites of fossil (or extant) life. Select, high-resolution images returned to Earth could then be analyzed, using a neural-network or artificial-intelligence computer program to recognize patterns in rock surface structures produced by endolithic biological activity. The program would be modified in the course of its development to enable it to discriminate between biogenic and abiotic patterns.

Proposed Instruments

This experiment would use imaging systems, placed on the surface of Mars, that are capable of resolving objects approximately 1 cm in size. The maximum number of such high-resolution images should be taken and relayed to Earth, where analysis would be performed.

This method is generally applicable for screening high-resolution images of any geological or geomorphological feature. It could greatly increase the success rate of costly sampling procedures by preselecting suitable areas with a minimum of expense and without additional and costly onboard equipment. It is expected that it could be developed within 3 or 4 years.

Because the experiment would use available video images, no technical problems are expected. The computer programs to be developed would be novel, but unlikely to present prohibitive problems.

Experimental Protocol

During a mission to the surface of Mars, select, high-resolution (~1 cm) images taken on the Martian surface would be transmitted to Earth for computer analysis. No real-time procedures would be required. After an initial computer screening, visual interpretations would be correlated with other data from the site. Pre-selected images would be visually analyzed at higher magnification, and sequential images would also be used for analysis with stereoscopic techniques. Variegated patterns that could have a biogenic origin would be noted. The interpretations made of the images would not lead to definitive conclusions about biogenicity. However, analysis could aid in the selection of samples to be returned to Earth.

Mission Compatibility

This experiment is designed to take advantage of any high-resolution images provided by devices on a lander, penetrator, egg, balloon snake tail, or rover.

Evaluation of Current Technology

The imaging systems on the Viking landers have already produced material of remarkably high quality. Imaging systems available today are well suited for the purposes of the proposed experiment, and further technological development should not be necessary. The software programs to aid in the interpretation of the returned images, however, would require development.

INFRARED LASER SPECTROMETER FOR *IN SITU* SENSING OF THE MARTIAN ATMOSPHERE

C. Webster, T. Owen, and D. Hunten

Objectives

The objective of this experiment is to determine the abundances and possible variability (in space and time) of minor gases and vapors (e.g., O₂, O₃, H₂O) in the Martian atmosphere; to establish isotope ratios of major elements (O, N, C, S) with high precision; and to look for nonequilibrium gases (e.g., CH₄, SO₂, and H₂S), which may be indicators of biological or geological activity.

This experiment would complement any analyses of volatiles and organics in soils made by other instruments. The isotopic information gathered would provide the basis for assessing long-term atmospheric evolution and the history of water and other volatiles on Mars. The discovery of any nonequilibrium gases or active geothermal areas would be of great importance to the science of exobiology.

Proposed Instruments

A high-spectral-resolution laser-diode spectrometer with folded-path optics is the recommended instrument to fulfill the objective of this experiment. The instrument would have a simple, fixed optical configuration and would be rugged and compact, with a mass of approximately 5 to 10 kg. Power and data requirements would also be low.

Experimental Protocol

If this instrument were operated during descent, it could acquire spectral measurements over the depth of the atmosphere. It would, however, be especially interesting to conduct this experiment from a rover. This would allow a search for local volatile sources and transient volatile releases, should they occur with concentrations large enough to be detected by the laser-diode spectrometer; the spectrometer would search for signs of volatiles or biogenic trace gases. Stable deployment of this instrument on the surface could also be useful, providing measurements over time of diurnal variations in the local atmosphere.

Mission Compatibility

This experiment could be conducted from a descending probe, a balloon, a rover, or any other suitable surface platform.

Evaluation of Current Technology

This instrument has already undergone a great deal of development and is being used in a number of applications, including tropospheric and stratospheric studies from balloons and aircraft, and ground-based industrial diagnostics and environmental monitoring. Currently there is ongoing definition and development of this laser spectrometer for use on the Titan probe of the Cassini mission.

THE DETECTION OF ANAEROBIC CHEMOAUTOTROPHS ON MARS

C. McKay

Objectives

The objective of this experiment is to search for anaerobic chemoautotrophs on Mars. Life may have survived on Mars in restricted or specialized niches; one possible niche is a hydrothermal vent. There has been no definite determination of recent volcanic activity on Mars, but the possibility cannot be excluded. Thus, it is possible that an underground geothermal vent in contact with permafrost provides the conditions necessary to sustain life. Liquid water would be provided by the melting of permafrost. Reducing gas (such as H_2S , H_2 , etc.) from the geothermal vent in the presence of Martian atmospheric CO_2 could provide an energy source for Martian chemoautotrophs.

Presumably, missions earlier than the Soviet Mars 94/96 mission, such as Mars Observer, would be involved in the search for sites of recent hydrothermal activity. Such sites could be recognized not only from thermal signatures but also from the presence of minerals associated with hydrothermal alteration. Thus, potential sites for an active biology experiment could be searched for by such orbital instruments as thermal spectrometers, atmospheric water vapor detectors, Visual and Infrared Mapping Spectrometers (VIMS), or other spectral instruments aimed at identifying trace amounts of biogenic gases, such as CH_4 or N_2O , in the atmosphere.

The search for extant life on Mars remains a compelling science driver for exploration of the planet. If prior orbital survey missions determine that there are present (or recent) sites of volcanic or hydrothermal activity on Mars, this will motivate the serious search for organisms capable of utilizing such sites—anaerobic chemoautotrophs. Instrumentation to conduct the search for these organisms could be based on the Viking Gas Exchange (GEx) instrument, minimizing technology development. Furthermore, such an instrument could share features with one designed to investigate the mineralogy and possible organic material at sites chosen for the search for evidence of extinct life. Although hydrothermal sites are emphasized in this proposal, the instrument concept is applicable to other sites whose characteristics are consistent with extant life.

Proposed Instrument

The proposed instrument for the detection of a possible Martian biota would consist of a reaction chamber into which Martian soil samples could be introduced along with a number of gases or liquids. The headspace gas in the chamber could be monitored or sampled to determine the consumption of reagent gases or the release of product gases. The chamber would have the ability to be heated to pyrolytic temperatures, decomposing any organic material within. The evolved gases would be analyzed by gas chromatography.

Experimental Protocol

The instrument concept described here is similar to the Viking GEx. Martian soil would be injected into an incubation chamber, where the temperature could be regulated. Various gases (H₂O, H₂, H₂S, etc.) could then be introduced into the chamber either alone or in combinations. If the sample is from a geothermal environment, the temperature of the chamber would be set to match the temperature of the environment from which the sample was obtained. As the sample incubates, the headspace gas would be analyzed to determine any changes caused by reactions within the chamber. This would be accomplished by withdrawing a sample of gas and analyzing it with a gas chromatograph (GC). The indication of microbial activity is the consumption of a feedstock gas (such as H₂) and the release of a product gas (such as CH₄, released from $4\text{H}_2 + \text{CO}_2 \rightarrow \text{CH}_4 + 2\text{H}_2\text{O}$). The chamber would then be heated to pyrolytic temperatures to decompose any organic material produced. Control studies would be needed to lessen the chance of confusion with mineral-mediated reactions.

Mission Compatibility

This instrument could be deployed on a penetrator or a rover. A major technical consideration would be sample handling and acquisition; sampling technologies for eggs and penetrators are as yet undefined.

Evaluation of Current Technology

The proposed instrument is based on the Viking GEx instrument. The major technology components, such as liquid water reservoirs, valves, actuators, etc., are already available. GC technology is also well developed. The Cometary Ice and Dust Experiment (CIDEX) instrument (gas and particle GC analysis system), which is under construction for the Comet Rendezvous/Asteroid Flyby (CRAF) mission, contains many of the subunits necessary for the instrument proposed here.

SUMMARY AND RECOMMENDATIONS

This report describes a wide range of instrument concepts for Mars missions; they address many of the major exobiological issues identified to date. Specifically, the instrument concepts relate to the search for (1) evidence for extinct life, (2) evidence for extant life, (3) geological evidence for paleoenvironmental conditions conducive to the early development of biota or prebiotic chemistry, and (4) evidence for contemporaneous surface processes. The experiments proposed also offer a variety of environments in which these lines of evidence might be sought. Some experiments are appropriate for regolithic sites occupied or formerly occupied by biota, some are appropriate for any regolithic site on Mars, and one is appropriate for atmospheric investigation.

There is equal variety in the technological methods proposed for conducting experiments; the techniques include gas chromatography, mass spectrometry, laser spectrometry, thermal analysis, neutron scattering, electrode sensing, specific-element detection, and pattern recognition. This variety potentially allows flexibility in accommodating exobiological experiments on highly constrained missions, such as those with penetrators or eggs.

Specific consideration was given to the matching of instrument concepts with candidate mission types. Some instruments (e.g., neutron spectrometer) were considered sufficiently light and compact that they could be accommodated within the snake tail of a balloon. Others (e.g., mass spectrometer) were considered most appropriate for landers or rovers, where mass and volume constraints are an order of magnitude less restrictive. For certain instrument concepts (e.g., differential scanning calorimeter/evolved gas analyzer), it was possible to define an evolving series of instrument configurations that can grow in sophistication in accordance with a growth in payload. For example, thermal analysis/processing of soil could be conducted by simple pyrolysis for very restricted payloads, but differential-scanning calorimetry could be used when payloads are least restricted. Similarly, some instruments (e.g., specific electrodes) were viewed as modular concepts, so that a central or core analyzer could be interfaced with a series of augmenting units as payload constraints permitted.

Specific consideration was also given to technology heritage. At the outset of the workshop, a brief "catalog" of technologies was made available that summarized the types of instruments and instrument subsystems that could be adapted from Viking, Pioneer, and other engineering designs. Workshop participants were requested to consider instrument concepts that made maximum use of this available technology. It transpired that in some cases the apparatus could directly utilize hardware that has Viking or Pioneer heritage; in other cases, the apparatus would only require reconfiguration of flight-proven hardware. (Some experiments do not even require flight hardware, but simply utilize the output from such generic equipment as cameras.) Those experiments proposing the use of "new" flight instruments would not require major technology development because the equipment has already been tested in other, Earth-bound applications.

The workshop provided a forum for the discussion of both scientific and technological aspects of Mars exobiology. A consensus emerged regarding basic exobiological objectives in the exploration of Mars (e.g., searching for both extant and extinct life, and understanding the basic chemistry of the Martian environment), although there was less of a consensus regarding the relative merits of different types of scientific information and the way in which the information should be sought (e.g., the

most definitive phenomena for indicating past life on Mars). Because the focus of the workshop was instrumentation, there was insufficient time to fully debate the exobiology science. A future workshop specifically addressing the science goals may be fruitful. The agenda of such a workshop might include consideration of the phasing of data acquisition, given the potential for a progressive increase in the sophistication of missions.

In light of the workshop, it is possible to recommend some activities that would help promote and consolidate near-term Soviet/U.S. cooperation in the area of exobiological exploration. The following are recommended:

1. A workshop focusing on the science strategy, as suggested above.
2. The selection, by existing joint Soviet/U.S. working groups, of potential exobiology exploration sites on Mars, and an agreement on the next stage of instrument development.
3. An immediate start of funding for the development of instrument concepts. This development would not include flight hardware, but would include concept feasibility studies, the testing and refining of analytical techniques, the calibration of instruments through the acquisition and testing of field analog samples, and the fabrication of breadboard prototype instruments.
4. A joint Soviet/U.S. workshop on exobiology and the Soviet Mars 94/96 mission. The agenda might include a briefing by the Soviets on the payload constraints likely to be imposed on near-term missions, current Soviet thinking on mission goals, and identification of candidate experiments for detailed development.

WORKSHOP PARTICIPANTS

Dale Andersen
Lockheed
600 Maryland SW, Suite 600
Washington, DC 20024
(202) 863-5258

Dr. Don Canfield
MS 239-4
Ames Research Center
Moffett Field, CA 94035-1000
(415) 604-5784

Glenn C. Carle
MS 239-12
Ames Research Center
Moffett Field, CA 94035-1000
(415) 604-5765

Dr. Michael Carr
U.S. Geological Survey
MS 946
345 Middlefield Rd.
Menlo Park, CA 94025
(415) 329-5174

Dr. Sherwood Chang
MS 239-4
Ames Research Center
Moffett Field, CA 94035-1000
(415) 604-5733

Dr. Ben Clark
Martin Marietta Corp.
Department 0560
P.O. Box 179
Denver, CO 80201
(303) 971-9007

Dr. Dale Cruikshank
MS 245-6
Ames Research Center
Moffett Field, CA 94035-1000
(415) 604-4244

Dr. Robert Day
TRW R1-1104
1 Space Park
Redondo Beach, CA 90278
(213) 812-0369

Dr. David Des Marais
MS 239-4
Ames Research Center
Moffett Field, CA 94035-1000
(415) 604-6110

Dr. Donald DeVincenzi, Chairman
MS 245-1
Ames Research Center
Moffett Field, CA 94035-1000
(415) 604-5251

Dr. Imre Friedmann
Dept. of Biological Sciences
Florida State University
Tallahassee, FL 32306
(904) 644-5438

Dr. W. R. Gardner
College of Natural Resources
University of California
101 Giannini Hall
Berkeley, CA 94720
(415) 642-7174

Dr. Harold P. Klein
Biology Department
Santa Clara University
Santa Clara, CA 95053
(408) 554-4496

Dr. D. Lowe
Department of Geology
Stanford University
Stanford, CA 94305
(415) 725-3040

Dr. Rocco Mancinelli
MS 239-12
Ames Research Center
Moffett Field, CA 94035-1000
(415) 604-6165

Dr. John Marshall, Co-chairman
MS 239-12
Ames Research Center
Moffett Field, CA 94035-1000
(415) 604-3668

Dr. Chris McKay
MS 245-3
Ames Research Center
Moffett Field, CA 94035-1000
(415) 604-6864

Dr. David Morrison
MS 245-1
Ames Research Center
Moffett Field, CA 94035-1000
(415) 604-5028

Professor Alfred Nier
School of Physics and Astronomy
University of Minnesota
116 Church Street
Minneapolis, MN 55455
(612) 624-6804

Dr. John Oro
Dept. of Biochemical and Biophysical
Sciences
University of Houston
4800 Calhoun Rd.
Houston, TX 77004
(713) 749-2828

Dr. James Pollack
MS 245-3
Ames Research Center
Moffett Field, CA 94035-1000
(415) 604-5530

Dr. Lynn Rothschild
MS 239-12
Ames Research Center
Moffett Field, CA 94035-1000
(415) 604-3213

Dr. Dale Rushneck
Chemex International, Inc.
225 Commerce Drive
Fort Collins, CO 80524
(303) 490-1511

Dr. Al Seiff
MS 245-1
Ames Research Center
Moffett Field, CA 94035-1000
(415) 604-5685

Deborah Schwartz-Kolyer
MS 239-12
Ames Research Center
Moffett Field, CA 94035-1000
(415) 604-4204

Dr. Carol Stoker
MS 245-3
Ames Research Center
Moffett Field, CA 94035-1000
(415) 604-6490

Dr. Robert Wharton
Desert Research Institute
P.O. Box 60220
Reno, NV 89506
(702) 852-5012

ADDITIONAL CONTRIBUTORS

Dr. Don Hunten
Dept. of Planetary Science
University of Arizona
Space Science Building
Tucson, AZ 85721
(602) 621-4002

Dr. Toby Owen
Institute for Astronomy
University of Hawaii
2680 Woodlawn
Honolulu, HI 96822
(808) 948-8312

Dr. C. Webster
Earth and Space Science Division
MS 183-301
Jet Propulsion Laboratory
4800 Oak Grove Drive
Pasadena, CA 91109
(818) 354-7478



Report Documentation Page

1. Report No. NASA CP-10055		2. Government Accession No.		3. Recipient's Catalog No.	
4. Title and Subtitle Exobiology on Mars				5. Report Date December 1990	
				6. Performing Organization Code	
7. Author(s) D. L. DeVincenzi, J. R. Marshall, and D. Andersen, Editors				8. Performing Organization Report No. A-90320	
				10. Work Unit No. 199-59-12-05	
9. Performing Organization Name and Address Ames Research Center Moffett Field, CA 94035-1000				11. Contract or Grant No.	
				13. Type of Report and Period Covered Conference Publication	
12. Sponsoring Agency Name and Address National Aeronautics and Space Administration Washington, DC 20546-0001				14. Sponsoring Agency Code	
15. Supplementary Notes Point of Contact: D. L. DeVincenzi, Ames Research Center, MS 245-1, Moffett Field, CA 94035-1000 (415) 604-5251 or FTS 464-5251 Proceedings of a meeting held at Ames Research Center on February 27-28, 1989.					
16. Abstract This report contains descriptions of several instrument concepts that were generated during a workshop titled "Exobiology Instrument Concepts for a Soviet Mars 94/96 Mission" held at NASA Ames Research Center on February 27-28, 1989. The objective of the workshop was to define and describe instrument concepts for exobiology and related science that would be compatible with the mission types under discussion for the 1994 and 1996 Soviet Mars missions. Experiments that use existing technology were emphasized. The concepts discussed could also be used on U.S. missions that follow Mars Observer.					
17. Key Words (Suggested by Author(s)) Exobiology Mars exploration Soviet spacecraft Mars soil			18. Distribution Statement Unclassified-Unlimited Subject Category - 55		
19. Security Classif. (of this report) Unclassified		20. Security Classif. (of this page) Unclassified		21. No. of Pages 42	22. Price A03

