

N91-16053

P-90

The Phoenix Pluto Probe Group 7

AAE 241
University of Illinois
April 24th 1990

Group Leader / Structures
Mission Management
Attitude and Articulation Control
Command, Control, and Communications
Propulsion & Power
Science & Instrumentation

George R. Gunning
Jeff Spapperi
Jeffrey P. Wilkinson
Jim Eldred
Dennis Labij
Meredith Strinni

George R. Humming



John P. Waltham



Jeffrey E. Spappori



Meredith S. Strimmi



~~John P. Waltham~~



James Elchott



~~John P. Waltham~~

Table of Contents

I	Mission Management.....	1-1
	Appendix of Equations.....	1-12
	References.....	1-13
II	Structures.....	2-1
	Introduction.....	2-1
	Subsystem Interactions.....	2-1
	System Layout & Description.....	2-2
	Mass & Inertia Configuration.....	2-5
	Mission Constraints and Requirements.....	2-7
	Environmental Hazards.....	2-9
	NEP Interactions.....	2-10
	Safety Issues.....	2-11
	Thermal Control.....	2-12
	Conclusion.....	2-12
	Appendix.....	2-14
III	Science Instrumentation.....	3-1
	RFP Requirements and Compliance.....	3-2
	Imaging Science Subsystems.....	3-3
	Near-Infrared Mapping Spectrometer.....	3-5
	Photopolorimeter - Radiometer.....	3-6
	Ultraviolet Spectrometer.....	3-7
	Magnetometer Subsystem.....	3-8
	Energetic Particles Detector.....	3-9
	Plasma Subsystem.....	3-10
	Plasma Wave Sensor.....	3-11
	Dust Detector Subsystem.....	3-11
	Micrometeoroid Detector.....	3-11
	Radio Science Subsystem.....	3-12
	Science Timeline.....	3-14
	References.....	3-15
IV	Attitude and Articulation Control.....	4-1
	AACS Requirements.....	4-1
	Design Approach.....	4-3
	Design Trades.....	4-3
	Initial Configurations.....	4-4
	Final Design Configuration.....	4-5
	Control Modes.....	4-7
	AACS Hardware.....	4-7
	System Integration.....	4-11

Design Problems.....	4-11
Discussion.....	4-12
References.....	4-13
V Power & Propulsion.....	5-1
Requirements.....	5-2
Method of Attack.....	5-2
System (Primary Thrusters).....	5-3
Possible Thrusters.....	5-4
Thrusters Selected.....	5-5
Propellant.....	5-6
Ion Dynamics.....	5-8
Specifications.....	5-9
Attitude and Articulation Thrusters.....	5-10
Power Source.....	5-11
Interactions with other Subsystems.....	5-12
Problems.....	5-13
Equations.....	5-14
References.....	5-15
VI Command, Control, & Communications.....	6-1
Summary of Abbreviations.....	6-1
References.....	6-14
Equations.....	6-15

Mission Management

The Phoenix probe which is our design for an unmanned probe to Pluto has an addition which was a driving force to Mission Management. This driving force was the potential use of a Nuclear Electric Propulsion (NEP) system. Though this will increase cost a great deal, its use has many far reaching effects on the space program. The NEP will not only be at least equal in performance to this mission, but will be shown that in the future it will be cost and performance effective for many missions to come.

Although nuclear power is under the propulsion subsystem, it has such an effect on trajectory and other options that I must study the two, trajectory and propulsion together, to reveal its true merits for interplanetary travel. The Nuclear Electric Propulsion system has many strong points that lend themselves to the use in such a mission. The strong points for NEP include a continuous supply of power especially away from the sun, low acceleration, and possible trip time savings. These trip time savings are good for long distance mission such as missions past Mars, but are not usable for manned missions. NEP also has a low fuel consumption and high specific impulse, thus making it attractive for missions with a high delta-V, which is definitely a problem when going to Pluto. Another reason NEP is attractive for the Phoenix Probe is the long life time of these reactors, allowing long duration missions with heavy payloads. In fact there was a study done which showed that for more missions expected of a vehicle the cost for NEP decreased. A final point for the use of NEP is that they are safe, increase reliability, and are operationally flexible.

With all these benefits, many of which apply to our probe, we decided to fly an Orbiter mission. The following chart lists the reasons that an orbiter was the best vehicle to fly.

	Flyby	Orbiter	Lander
Scientific:	Minimum Time	Sufficient Time	Maximum Time
Cost:	Inexpensive	Expensive	Very Expensive
Payload:	Light Load	Heavy Load	Heavy Load
Misc:	No Benefits	Future Uses	Unknown surface

As shown on this chart for a Flyby a chemical Propulsion system would be best suited since a Flyby would not utilize a NEP systems strong points. If we consider the distance were going for only one planet with no additional benefits it does not seem to be a wise choice for a mission. For a Lander mission the NEP system works well since it would be a high delta-V mission with a heavy payload, but we don't know anything about the surface so a lander would be a difficult task. We also considered a landers information not equally beneficial for the increased cost, since Pluto is so far away. We decided to Fly an Orbiter mission that would allow our scientific equipment to take more accurate measurements. Measurements with the on board photopolarimeter, solid state Imaging, near Infrared spectrometer, and visible and ultraviolet spectrometer will give us a complete layout of Pluto's thermal properties, landscape, mineralogy, and atmosphere. An Orbiter mission also takes advantage of using the NEP system because it will be a heavy load and an original design, and this new design will be a helpful development for future spacecraft.

The development of a NEP system for our mission is a great advantage for an Orbiter, but there are many missions in the future that would benefit from this technology in cost, time, and performance. In fact many AIAA papers (1,2,3,5,8) think that it is the propulsion system of the future. One mission of the future that would benefit is TAU-a mission to a thousand AU's. This mission is dependent on

NEP if it were to go 1000 AU's in 50 years, to make measurements of the distances to the stars in our own galaxy. A Mars cargo transport mission is also a mission that NEP severely out performs chemical propulsion in the time to get to Mars and payload carried. Therefore when the Mars initiative begins they would use NEP to send the cargo ahead and have the astronauts rendezvous with it in orbit. A trip back to Neptune using a nuclear propelled Orbiter would take only 10 to 12 years. Using NEP system out performs chemical system when constructing on Orbital Transfer Vehicle(OTV). When this comparison of a NEP OTV vs. a chemical OTV was done it was shown that after initial development, NEP was about \$250 million cheaper. This reduced cost over chemical is resulting primarily from reduced propellant consumption and from the larger number of missions which can be accomplished by the single nuclear stage. As shown all these missions plus others are severely benefited by the use of NEP, therefore the sooner it is developed, the sooner it can be implemented to these missions.

The Selection of a launch vehicle for this mission was narrowed down by the fact that our spacecraft weights 24,914 kg. Therefore we could initially eliminate the possibility of using most of today's U.S. launch vehicles, with the exception of using possibly two Titan rockets. We could use two commercial Titans, or Titan 4NUS (Type 1 or Type II). The problem with this would be that we would have to assemble our spacecraft in orbit, which could be done at the space station, but the cost to do all this would be higher than launching it in one launch vehicle not to mention an on-orbit assembly cost.

Another possible launch vehicle would be the Soviet Union's Energia. This launch vehicle is capable of delivering payloads weighing more than 100 tons(90,800 kg.) into a low earth orbit.(6) This payload weight should be sufficient to lift our spacecraft to LEO, plus an upper stage, to lift it into a nuclear safe orbit of approximately 700 km. The obvious difficulty with this

is securing the use of Energia from the Soviets. The politics of such an act in itself would be a large accomplishment and if political breakdown occurred then we would be stuck with an expensive spacecraft stranded on the ground.

Other than these two options all the other worlds current launch vehicles can be excluded from evaluation because they would need multiple launches to get our spacecraft in orbit. The cost would be astronomical and on-orbit assembly would be almost impossible, thus satisfying the RFP requirement of minimizing on-orbit assembly. To make our mission at all realistic in a cost and possibility standpoint a requirement is for the U.S. to develop a Heavy Launch Vehicle(HLV). This development is already being considered and planned to satisfy the future needs of NASA.(7) Studies established that a cargo vehicle with increased lift capability (>100,000 lbs.(~45,400 kg.)) would be required by the mid-1990's, to satisfy anticipated civil, commercial, and defense needs.(7) The main goal in these developments is to bring the cost of lifting vehicles to \$300/lb of payload delivered to LEO.(7)

The Shuttle-C vehicle can satisfy a variety of missions and meet emerging payload requirements.(7) As currently envisioned the Shuttle-C will be a launch vehicle capable of delivering a minimum of 100,000 lbs. (45,400 kg.) of usable cargo to an altitude of 220 NM (407 Km). The vehicle will be operational in the late 1994 time frame and will incur minimal facility impacts and developmental costs.(7) The Shuttle-C plus an appropriate upper- stage should be able to get our Phoenix probe into a Nuclear Safe orbit(NSO). Therefore the Shuttle-C is the most likely choice for the Phoenix probe and this covers the requirement of identifying the use of a space shuttle.

The final considerable launch vehicle would be the Advanced Launch System(ALS). The objective of the ALS program, being jointly developed by

DoD and NASA, is to define a launch system with a vehicle capable of placing payloads up to 200,000 lbs. (90,800 kg in low earth orbit at a fraction of the cost of today's launch systems.(7) This system design is being cost driven to reduce the total delivery cost to orbit to one-tenth of the anticipated cost for the Titan 4. In addition the launch vehicle must be highly reliable, easily supported and maintained, and responsive to changes in mission requirements.(7) This system has some conflicting information in that some articles say it will be available in the late 1990's while others imply a much longer development time, which I have a feeling is more likely. If this system is in operation at our prescribed launch date it will definitely be the launch system of choice by a cost standpoint.

Out of all of these vehicles the Shuttle-C will probably be our launch vehicle. Shuttle-C is most likely to be ready on time for our mission, cheaper than two vehicles, and easier and more dependable than using Energia, since it will be U.S. made.

To begin in the design of a trajectory I had to first determine what planets would be possible to flyby and thus making the design able to perform several possible missions, an RFP requirement. To determine this I plotted the planets in their approximate positions, at the time that our spacecraft could reach them, with a Earth launch window between 2000-2010.(figure 1) For example Uranus is located where the dark arc is on the circular orbit. The dates on that arc are from 2010 to 2020 assuming an approximate trip time to that distance of ten years. This launch window from 2000-2010 satisfies the RFP requirement. As can be see from this figure, none of the outer planets (Saturn, Uranus, or Neptune) will be aligned with Pluto, therefore these planets are excluded from consideration. Mars and Jupiter are a different story, they will be lined up with Pluto during our launch window. Mars' position is not shown on (figure 1) because it will travel around the sun approximately five and a half times during the launch

APPROXIMATE POSITIONS OF
 OUTER PLANETS AT TIME OF
 POSSIBLE FLYBY'S WITH
 LAUNCH DATE BETWEEN 2000-2010

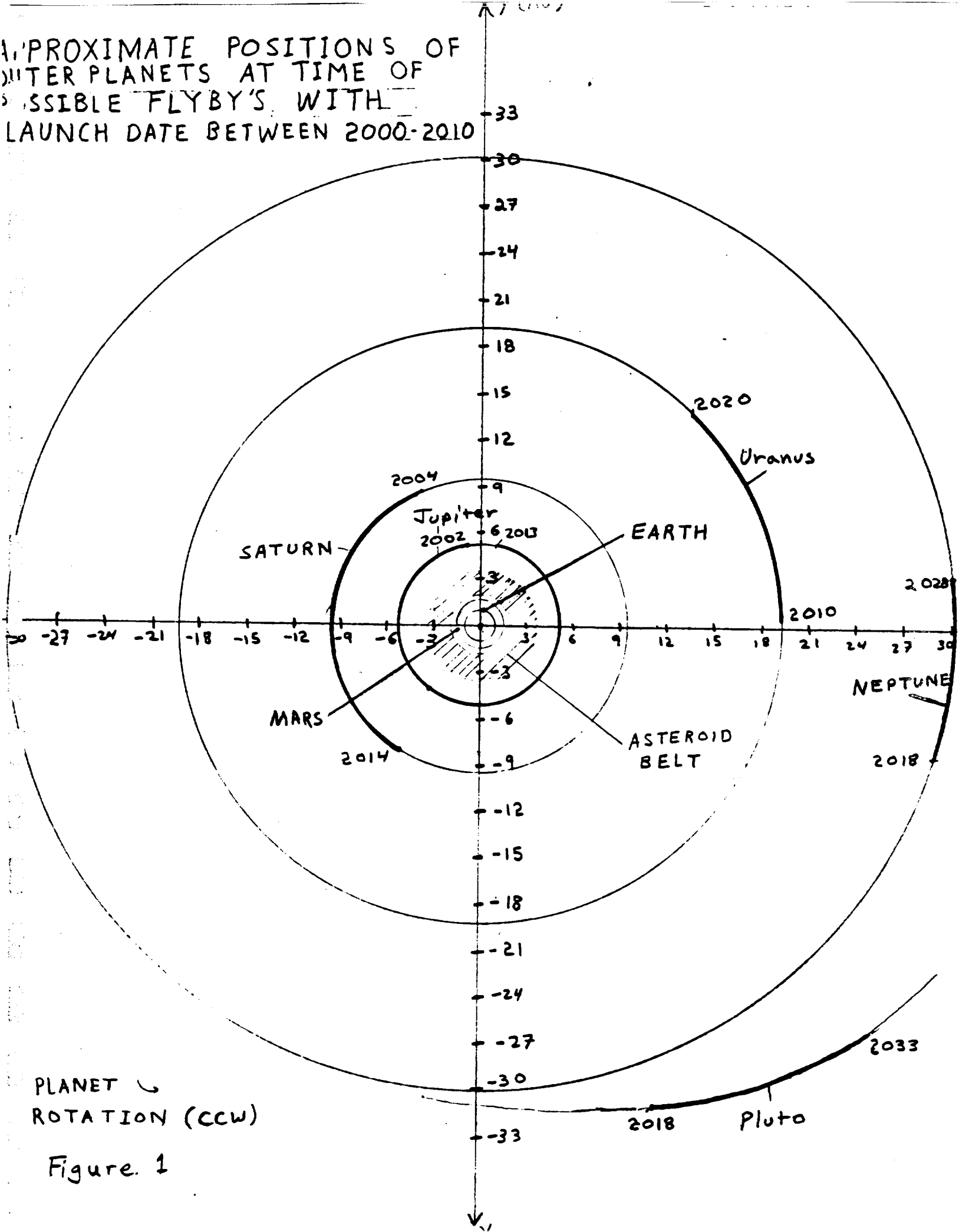

PLANET ↻
 ROTATION (CCW)

Figure. 1

window. A flyby with a gravity assist at Jupiter should give us a tremendous acceleration out to Pluto, so I will try to include this in our trajectory. The other possible flyby's would be Mars and an asteroid. The Mars flyby would be beneficial to help the Mars initiative by searching for a landing site. With reference to the asteroid it is NASA policy that all missions that transverse the asteroid belt should include an asteroid flyby if at all possible, which should not be too hard with 12,000 asteroids out there.

Once I considered what possible missions could be done in addition to our Pluto Orbiter I began our trip to Pluto. First we launch the spacecraft up into Leo and then we use an upper stage, most likely a Centaur, to put the Spacecraft up in a NSO orbit of 700km. At this point we deploy many of the spacecraft booms and scientific equipment. Finally we turn on our Nuclear Electric Propulsion system and our trip begins.

The First part of this trip is to get out of Earth's sphere of influence(SOI). The choice's are to either spiral out of the SOI or to insert into heliocentric space with some booster. The spiral trajectory was chosen because it has a lower mission cost and this spiral out trajectory has direct relevance to future electric propulsion orbit transfer vehicles. The actual spiral trajectory of our Phoenix probe looks very similar to figure 2. The approximation I received using Cheby2 indicates it will take close to 232.3 days to spiral out to escape velocity. During the spiral away from the Earth our spacecraft will revolve around the earth nearly 900 times, thus allowing time for a system checkout. The velocity at NSO will be 7,452 m/s but as the spiral continues it will slow to a final speed of 958 m/s at SOI escape. The last 50 days of this spiral can be seen to be flattening out, this is because the Sun's gravitational influence is becoming stronger than the Earth's. At 925,000 km. from the Earth our Phoenix probe will reach the edge of the Earth's SOI and the origin of the system switches from the Earth to the Sun and our interplanetary trajectory begins.

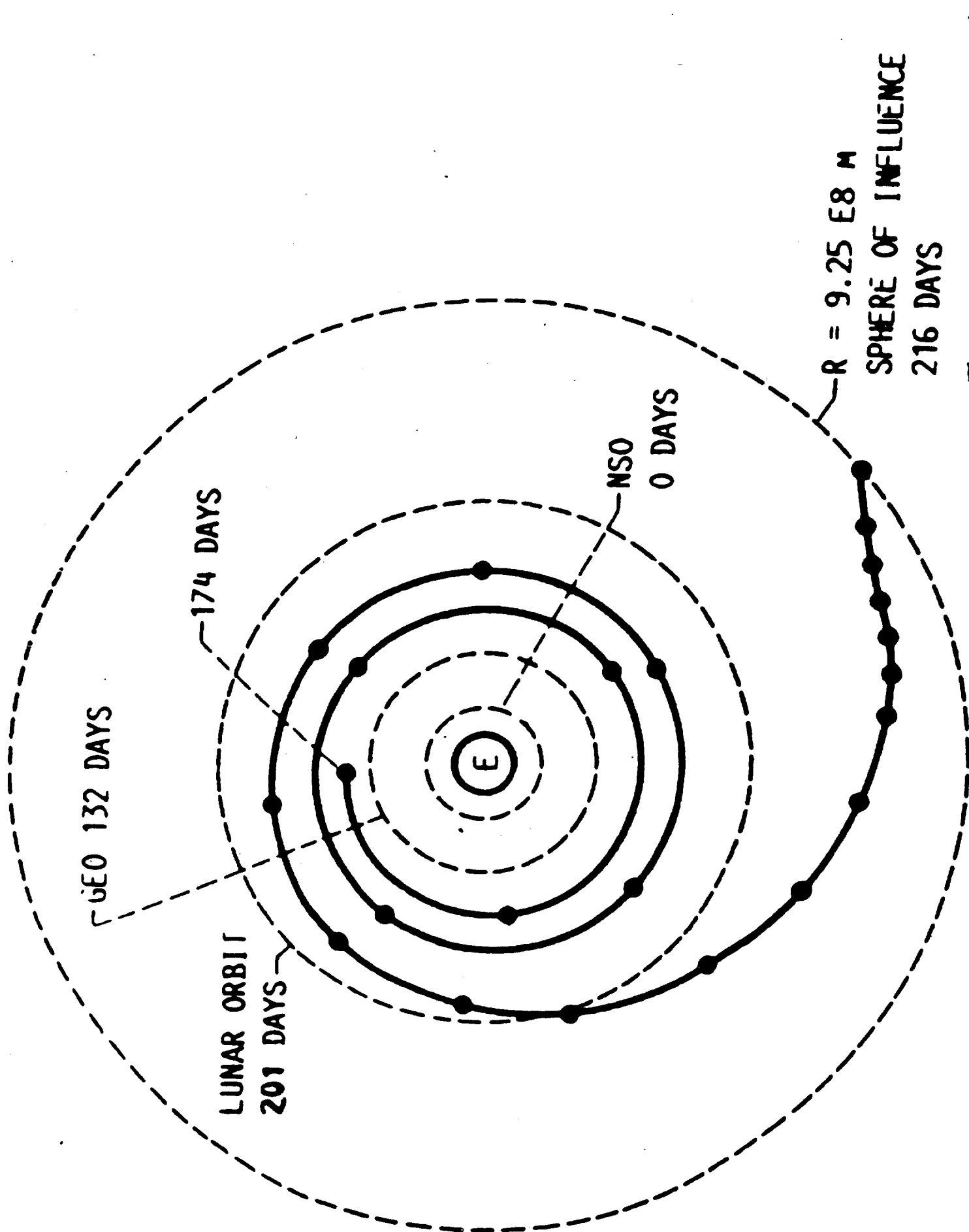

Figure 2 (Reference 1)

All low thrust trajectory analysis was accomplished using the computer code CHEBYTOP2(Chebychev Trajectory Optimization Program). Cheby2 is a multi-purpose trajectory program to optimize either mass or power for low thrust trajectories of either NEP or Solar Electric Propulsion(SEP). I used it to allow simple estimates for variable power from different planets with spiral escapes and spiral capture. The basic information that I used includes; Mass=20,750 kg, Isp=5500, Power=100 kW, Propulsion system specific mass= 57.3, and a power level of 87%. A technical problem that I had was that most of the numbers stated within this paper are at most rough estimates, since this program does not allow for many options and the use of it was limited by the lack of knowledge of its internal working and proper inputs.

The interplanetary travel begins just after leaving Earth's SOI with a solar system speed of close to 30,500 m/s. I ran two scenarios on Cheby2. The first one was a trip from Earth directly to Pluto. The second case prepared consisted of a mission from Earth to Pluto with a swingby at Jupiter. The first case from Earth directly to Pluto included a spiral out of Earth's SOI and a spiral into a elliptical orbit around Pluto. The launch date is to be 2451546 Julian date(JD), Jan. 3,2000, and took approximately 18.5 years. The trajectory when mapped onto galactic map does not look very efficient, this might be caused by the fact that Cheby2 optimizes for power or mass and not for time. This case takes a very long time and is an unlikely choice although our probe could survive that long. This scenario requires the propulsion system to be on for roughly 17.1 years , which our system could handle since it has a lifetime of approximately twenty years. This trip time is again just approximate and with some optimization for time it could be reduced.

The second case of a trip to Pluto with an Jupiter gravity assist came out to be more realistic. The trip time was close to 15 years, with a launch

date of 2453095 JD, April 2, 2004, and an arrival date at Pluto of 2458599 JD, April 30, 2019. This trip time of 15 years (5504 days) is more realistic and a better choice over case 1. While analyzing the data for this case I noticed that the trip from Earth to Jupiter, the first 1100 days, seemed very inefficient and has room for improvement. The propulsion system was required to be on for roughly 14 years, thus allowing a great deal of propulsion on time around Pluto. These numbers are just approximations with little or no time optimization.

The reason I stress that these numbers from Cheby2 are approximations is because out of a couple of sources(3,9) information was given for trajectories to Neptune. These missions to Neptune are almost exactly like ours to Pluto, because they use an Orbiter mission, Isp values of 5300 to 5978, and power of 100 kW. The only difference is the fact that they are going to Neptune instead, but in the year that we are planning our mission, Pluto is only 3 to 6 AU's farther away. These papers list trip times of 10-12 years to Neptune, therefore to go an extra couple of AU's shouldn't add more than possibly two years. This indicates a trip time to Pluto of 12-14 years.

A comparison of flight times to get an Orbiter to Pluto using chemical propulsion is just about the same. In fact the best trip time I got with the lowest delta-V was over 15 years also. So there are really no savings in the way of using chemical propulsion, in fact NEP might even get us there faster considering the mass of the Orbiter.

These missions that I planned show no Encounters with Mars nor asteroids. These are not included because Cheby2 does not allow such additions to your flight path. These missions would be very likely to be included although I was unable to determine when they could occur if they could occur. Another obstacle to find an asteroid flyby is to do this there would be a lengthy process of going through 12,000 asteroids and finding

those that are near our optimal trajectory.

The orbiting of Pluto is interesting in that on the way there we will have to reverse our thrust vector to begin slow the spacecraft down so that it can enter orbit around Pluto. This reverse thrust should begin to occur 4.6 years before Pluto is reached. Also we will have to do trajectory checks with our sensors to define our position here and along the whole mission to stay aligned with our trajectory. This is very important with a NEP system for we need a longer time to correct trajectory discrepancies. The final insertion into orbit around Pluto will be a spiraling right into an elliptical orbit. With the NEP propulsion system lasting long enough to do all of the scientific studies of Pluto we should be able to raise our orbit and do scientific studies of Charon. The end of our mission will occur when the NEP system finally gives out and we receive no more communications from our Phoenix probe. The two reactors on board should last us up to twenty years and this lifetime is long enough for an adequate safety margin to meet the RFP requirement of being able to carry out our mission plus others. With all this information I have assembled a time line (figure 3) that use case 2.

Costing for our mission is done on figure 4, which itemizes the direct labor, recurring labor hours, and total cost for each subsystem. Our mission cost comes to \$4.215 billion to complete whole mission minus the cost of the launch vehicle, which was unattainable since the Shuttle-C is not built yet. This cost estimate includes four spacecraft to be built, thus satisfying the RFP requirements. Although this is an exuberant amount of money you have to weigh this with the new cost efficient subsystem that are being designed, especially the propulsion system. The development of the NEP system is approximately one-third the total cost, so otherwise if this was taken out of our costing the spacecraft would be more cost effective. This price is in disagreement with the RFP, but again one must weigh that against the originality of such a project and it's future benefits.

Costing - figure 4

	A	B	C	D	E
1	Itemized costing				
2					
3		Mass (kg)	Direct L Hours	Recurring L.H.	Total Cost
4	DEVELOPMENT PROJECT		1000 hours	1000 hours	millions \$
5	Structure & Devices	2758	4796	854	158.7
6	Thermal Control	35	158	49.4	5.4
7	Propulsion	12000	12604	8851	598.4
8	Attitude & Articulation	46.1	739.7	178.1	10.3
9	Telecommunications	62	1831.9	414	23.4
10	Antennas	304	10820	2030	297.6
11	Command & Data Handling	18	215.9	47	6.4
12	RTG Power	5516	7908.1	6123	238.9
13	Landing Radar / Altimeter	50	1303.5	363.7	34
14	Line-Scan Imaging	30	2366.9	636.6	37.4
15	Particle & Field Instruments	49.3	1195.7	483.4	22.6
16	Remote Sensing Instruments	42.1	401.9	32.6	3.7
17	Sampling Instruments	3.5	89.5	15.9	1
18	SUPPORT FUNCTIONS				
19	System Support		7307		237.1
20	Launch + 30 days Operations		2388		82.2
21	Imaging Data development		66.5		2.4
22	Science Data Development		150.3		7.6
23	Program Management		2454.4		76.2
24	FLIGHT PROJECT				
25	Flight Operations		10570		358.2
26	Data Analysis		4492.3		160.6
27					
28			Total cost in	1977 dollars=	\$2244.2 Million
29					
30			Total cost in	1990 dollars=	\$4,214.6 Million

ORIGINAL PAGE IS
OF POOR QUALITY

11A.

Appendix of Equations

Cheby2 Equations

$X + kx/r^3 = a$ where X =Position vector

a =Acceleration vector

k =Gravitational constant of sun

$r=|X|$

Constant Isp

$|\dot{a}| = (a_0 / u)(p/p_0) \sigma(t)$ & $du/dt = -(a_0 / c)(p/p_0) \sigma(t)$

where: a_0 = Initial acceleration at 1AU

c =Exhaust velocity

u =relative mass of vehicle

$\sigma(t) = 1 \rightarrow$ powered or $2 \rightarrow$ coast

Costing Equations

$TC = (100\% - Z)NRC + RC$

$NRC = DLC - RC$

$DLH = DLH(2, M) + (N - 2) * (RLH(2, M)) / 2$

where: TC = Total cost

NRC = Non-recurring cost

RC = Recurring cost

DLH = Direct labor hours

RLH = Recurring labor hours

References

1. Galecki, D. L. and Patterson, M. J. , " Nuclear Powered Mars Cargo Transport Mission Utilizing Advanced Propulsion," AIAA Paper No. 87-1903, June-July 1987.
2. Mahoney, S. P. , "Nuclear Powered Ion Engine Orbit Transfer Vehicle Design and Operational Effectiveness," AIAA Paper No. 86-1391, June 1986.
3. Aston, G. , "Ion Propulsion Technology Requirements for Planetary Mission Applications," AIAA Paper No. 85-2000, Sep.-Oct. 1985
4. Parvez, S. and Holman, J.M.L., "Low Thrust Insertion Into Orbit Around Mars," AIAA Paper No. 87-0093, Jan. 1987
5. Ramsthaler, J.H. , "Comparison of Advanced Nuclear and Chemical Propulsion," AIAA Paper No. 88-2927, July 1988
6. Gubanov, B.I., "Energia - New Soviet Launch Vehicle," IAF Paper No. 88-172, Oct. 1988
7. Branscome, D.R. , " NASA Launch Vehicles- The Next Twenty Years," IAF Paper No. 88-189, Oct. 1988
8. Nock, K. T. , "TAU - A Mission to a Thousand Astronomical Units," AIAA Paper No. 87-1049, May 1987
9. Garrison, P.W. , "Nuclear Electric Propulsion Spacecraft Configurations study," AIAA, April 1983
10. Friedlander, A. , "CHEBYTOP2 (Chebychev Trajectory Optimization Program)," Science Applications International Corporation, Sponsored by Boeing.
11. Costing Estimate done with Notes given in AAE241 , Spring semester, 1990, University of Illinois, TA: Koepke, A.

ACRONYMS

RFP	Request For Proposal
NEP	Nuclear Electric Propulsion
C3	Command, Control, & Communication
STC	Structural and Thermal Control
A&AC	Attitude and Articulation Control
HGA	High Gain Antenna
LGA	Low Gain Antenna
I & C	Instrumentation and control
MAG	Magnetometer
HTR	High Temperature Radiator
JPL	Jet Propulsion Lab

Introduction Structures and Thermal Analysis

The structural analyst in the Phoenix space probe serves three roles; structural design, thermal control and material selection. It is the responsibility of the analyst to make sure that the space probe maintains its integrity for the entire mission. Therefore it will be shown that the Phoenix probe meets its requirements in the *Request For Proposal*. (RFP). Each requirement will be presented along with a description of how this requirement is satisfied. A design configuration will be illustrated along with a description of each component and its interaction with the other components. A mass / inertia configurations will be shown as well as descriptions of launch vehicle compatibility, on - orbit assembly, materials selected, thermal control considerations, and safety issues of Nuclear Electronic Propulsion (NEP). Also, a description of how the structural analyst interacts with the science, propulsion, attitude and articulation control, command, control, and communication (C³), and mission management will be presented.

SUBSYSTEM INTERACTIONS

Structures and Thermal Control (STC) is a highly interactive subsystem. STC must work with Mission planning in order to maintain low

costing, select a compatible launch vehicle, and most importantly develop a spacecraft configuration that is ideal for a Pluto orbit insertion mission. For the science subsystem STC must provide a clear field of view for the scientific equipment, and maintain equipment at normal operating temperatures. STC provides Attitude Articulation and Control (A&AC) with approximate masses and inertias so that we will maintain stable flight. As with science, STC must maintain C³ equipment at ideal operation temperatures and provide a clear field of view for the High Gain Antenna (HGA) and Low Gain Antenna (LGA). And finally, Power and Propulsion plays a very important part with STC. The reactors provide 100% of the thermal control for the Phoenix. Also the highly radioactive plume and reactor play a major role in the placement of components.

SYSTEM LAYOUT & DESCRIPTION

Numerous NEP spacecraft configurations have been proposed. Figure 1 illustrates the Phoenix Pluto probe. In this configuration the thrust vector is orthogonal to the vehicle longitudinal axis and the reactor and payload are at opposite ends. The side thrust and end reactor configuration was selected because this design avoids many of the conflicting subsystem requirements that will be discussed later. A clear field of view are provided for the high temperature power system. Thermal control problems are minimized by integrating the spacecraft subsystems along the thermal gradient. ²

The power module consist of two reactors, a Reactor Instrumentation and Control (I & C) subsystem, shield, heat transport subsystem, power conversion subsystem and the heat rejection panels. The total length of the deployed power module is 11.3 m with the heat rejection panels extending to a diameter of 6.9 m. There are two attitude and articulation thruster units attached the power conversion system directly along the z - plane.

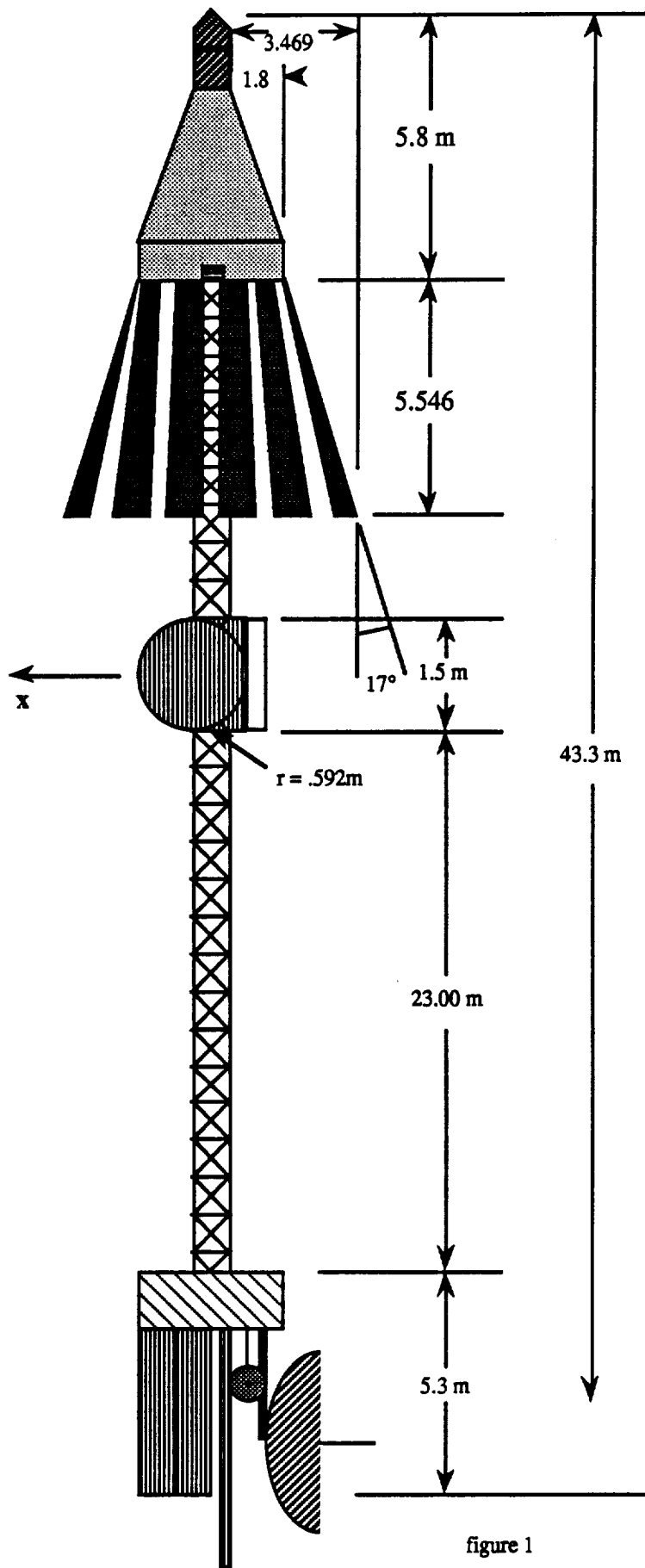

POWER MODULE

- 2 Reactors
- Reactor I & C
- Shield
- Heat Transport System
- Power Conversion
- High Temperature Radiator (HTR) panels
- a.k.a. heat rejection panels

PROPULSION

- Propellant Tank
- 6 Main Thrusters

PAYLOAD

- Main Platform (AAC housing)
- Science & C3 Housing
- HGA (4.8m diameter)
- LGA
- MAG boom (13m)

figure 1

Phoenix Launch Ready

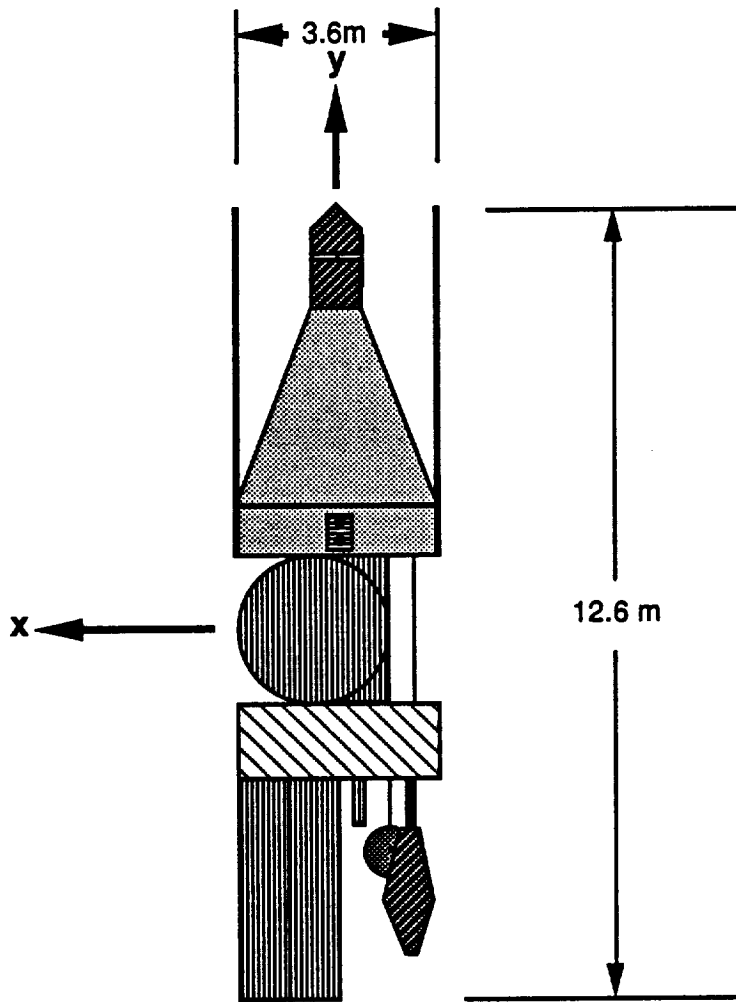

figure 2

The propulsion module is placed on the center of gravity to minimize any unwanted torque due to the thrust. Mercury propellant will be stored in a cylindrical vessel attached directly behind the main thruster unit. The main thruster unit will include the six thrusters needed for our mission. Placed 23 meters down the truss is the payload module. The payload module consist of a main structural platform with a 4.8 m diameter HGA, LGA, Magnetometer (MAG) boom, and a science and communication housing attached. The main platform is designed to house the four reaction wheel assemblies used by A&AC. The science and communication housing

features four panels that are kept closed during the majority of the mission in order to protect the equipment from contamination. Once we reach Plutonian orbit and the thrusters are turned off, the science panels are opened allowing a full field of view of Pluto's surface.

Figure 2 shows the Phoenix in takeoff configuration. Notice that the High Temperature Radiator (HTR) panels fold upward. The A&AC thrusters retract in Power Conversion module. The Power and Propulsion boom also retracts into the Power Conversion module and the Payload boom retracts into the payload main platform. On the payload platform the MAG boom retracts and the HGA antenna folds up into its stowed configuration.

Completely stowed, the Phoenix has a length of 12.6 m a diameter of 3.6 m and mass of 20,914 kg (see table 2). The shuttle C is being designed for a 4.57 m diameter, payload length of 25 m, and payload mass of 45,359 kg. Plenty of room and mass is available for packing to insure a safe takeoff.

MASS AND INERTIA CONFIGURATION

A summary of the mass breakdown is shown in table 2. A contingency of 20% of the total (dry) system mass is included. The net payload module is 1852.6 kg. An interesting note is that an additional 570 of payload could be added without any additional cost in terms of system interactions. This was calculated with torque and thermal gradient considerations. As shown the net power and propulsion system dry is 5576 kg. But propellant adds an additional 12,000 kg. The subtotal (wet) came out to be 20,914 kg. This mass is only 5.1% different from our initial estimate made during the response to the proposal. Figure 3 shows the simplified diagram of the Phoenix that was used to calculate the mass moment of inertias. The values of these inertias may be found in the appendix.

Table 1 Phoenix Subsystem Mass

ITEM DESCRIPTION	MASS(kg)
SCIENCE	156.5
IMAGE SCIENCE SUBSYSTEM	30.0
NEAR INFRARED MAPPING SPECTROMETER	19.5
INFRARED SPECTROMETER	8.2
PHOTOPOLARIMETER RADIOMETER	5.1
EXTREME ULTRAVIOLET	12.3
ULTRAVIOLET	5.2
MAGNETOMETER	5.3
PLASMA WAVE SENSOR	7.2
PLASMA SENSOR	13.2
COSMIC RAY	10.0
DUST DETECTOR	8.5
HEAVY ION COUNTER	4.4
CELESTIAL MECHANICS	10.0
RADIO PROPAGATION	7.6
RADIO MAPPING	10.0
COMMAND CONTROL & COMMUNICATION	350
S/X BAND ASSEMBLY	4.7
ANTENNA CABLING	3.5
DATA STORAGE SYSTEM	8.6
COMMAND DETECTOR UNIT	10.0
RFS	50.0
HGA (PARABOLOID)	200.0
LGA (HALF-WAVE DIPOLE)	50.0
UNCERTAINTY	23.2
ATTITUDE ARTICULATION & CONTROL	46.1
TWO AXIS SUN SENSOR (2)	3.2
INERTIAL MEASUREMENT UNIT	15.0
STAR SENSOR ASSEMBLY	4.3
FOUR REACTION WHEEL ASSEMBLIES	25.6
PAYLOAD MODULE STRUCTURE (INCLUDING BOOM)	1300
POWER & PROPULSION (DRY)	5576
PRIMARY THRUSTERS (6)	636.0
A A & C THRUSTERS (12)	340.0
REACTOR (2)	1280.0
SHIELD	860.0
HEAT TRANSPORT	445.0
REACTOR I & C	210.0
POWER CONVERSION	315.0
HEAT REJECTION	835.0
POWER CC & D	370.0
STRUCTURE	285.0
SUBTOTAL, LESS CONTINGENCY	7428.6
CONTINGENCY (20%)	1485.72
SUBTOTAL PHOENIX (DRY)	8914.32
PROPELLANT	12000.0
SUBTOTAL PHOENIX (WET)	20914.32 kg

PHOENIX MASS/INERTIA CONFIGURATION

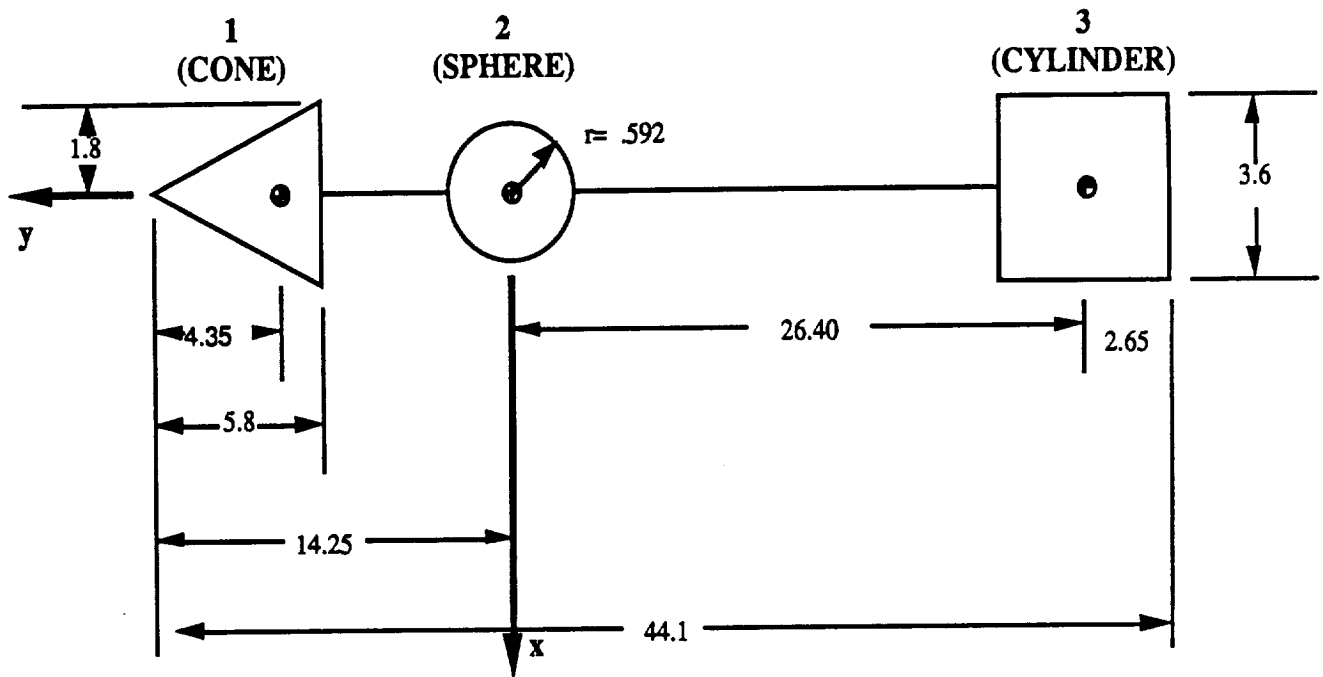

(all lengths are in meters) $M_1 = 5,928 \text{ kg}$ $M_2 = 12,7632 \text{ kg}$ $M_3 = 2223.12 \text{ kg}$

figure 3

Mission Constraints and Requirements

Here is a description of a few of the constraints and requirements given by our project manager and implied by the structural analyst. For a concise listing table 2 illustrates the requirements related to the structural design and summarizes where they are met.

According to the RFP all materials must be available up until 1999. All structural materials for the Phoenix already exist. The support booms are currently flight proven. And the science and communications module will be similar to that of the Galileo and Voyager. But the thermal control of the SP-100 propulsion system has not been thoroughly tested. According to J.F. Mondt of the Jet Propulsion Laboratory (JPL) the generic flight system of the SP-100 will be proven reliable by April 1995.³

The use of off-the-shelf hardware is very important in the design of Phoenix. First of all it reduces design and development cost that should be

Table 2 Structural And Thermal Design Requirements

REQUIREMENT	COMPLIANCE
1. Demonstrate understanding of RFP.	Throughout paper.
2. Describe technical approaches used to comply with RFP.	Done in each section.
3. Identify critical problem areas.	Done for each section.
4. Include sensitivity analyses and tradeoff studies.	Done were applicable.
5. Describe method of attack.	MISSION CONSTRAINTS&RQMNTS.
6. Spacecraft must adapt to space environment.	ENVIRONMENTAL HAZARDS & NEP INTERACTIONS
7. Materials used available before 1999.	MISSION CONSTRAINTS&RQMNTS.
8. Identify & minimize on-orbit assembly.	SYSTEM LAYOUT & DESCRIPTION
9. S/C should have sufficient lifetime plus reasonable safety margin.	MISSION CONSTRAINTS&RQMNTS.
10. Stress reliability, low cost, simplicity.	MISSION CONSTRAINTS&RQMNTS.
11. Weight & cost should be optimized.	MISSION CONSTRAINTS&RQMNTS.
12. S/C should be able to perform several missions.	MISSION CONSTRAINTS&RQMNTS.
13. Off-the-shelf hardware should be used.	MISSION CONSTRAINTS&RQMNTS.
14. S/C should not be a threat to environment or public safety.	SAFETY ISSUES
15. Show & identify layout of components & size.	SYSTEM LAYOUT & DESCRIPTION
16. Verify launch vehicle compatibility.	SYSTEM LAYOUT & DESCRIPTION
17. Give approximate mass & inertias.	MASS/INERTIA CONFIGURATION
18. Describe S/C thermal analysis.	THERMAL ANALYSES
19. Identify materials used.	Done in each section.
20. Show interaction with other subsystems.	SUBSYSTEM INTERACTIONS

directed towards the developing SP-100 propulsion system. The storable HGA, MAG boom assemblies have been featured on the Galileo.

Unfortunately, since the Phoenix is such a unique spacecraft, most of the structural components will have to be built for its special configuration. For

example, its 30.7 m boom assembly and payload design will be unique. But on the other hand, the materials and methods used to construct these components have been available and flight proven. For example, Carbon fiber/epoxy a light weight, high strength and stiffness material with a tailorable coefficient of thermal expansion and 15 years of proven experience will be used in the boom assembly and support trusses. ⁵

ENVIRONMENTAL HAZARDS

The Phoenix Pluto probe has a complicated array of environmental hazards that it will encounter. First is the wide range of temperatures that exists from Earth's atmospheric temperature at take-off to Pluto's orbit that will extend to approximately 34 au for our mission. At these distances the temperature can reach a chilly 42 K. To protect the Phoenix from the effects of such cold temperatures, measures must be taken to keep the all systems within its operating temperatures. These measures will be outlined later in the Thermal Control description.

A second environmental hazard is the meteoroid environment. Large meteoroids are rare in space. Therefore it can be assumed for the purpose of this mission that we do not have to design for this condition. But on the other hand the more numerous smaller meteoroids can present a problem. The effects of these micrometeoroids can be compared to a sandblasting operation ¹. Three systems will be in need of protection; the thin HTR panels, support booms, and the science and communications module. To protect the HTR panels Beryllium Armor will be exposed to the outside surface. To keep the boom assembly from unnecessary exposure it will be enclosed in a single layer Kapton sock. And finally the science module shielding will be roughly equivalent to that of the Galileo spacecraft (0.5 cm aluminum). ²

A third environmental hazard is radiation. Radiation destroys the

orderly structural arrangement of the metals used in spacecraft. Radiation will come from two sources. The first is natural space radiation and the second is the nuclear reactor and exhaust plume. Usually a NEP type spacecraft takes longer to escape earth's radiation belts so radiation shielding is important. But in comparison, the Galileo spacecraft was designed for an intense Jovian environment, and the radiation exposure of these two spacecraft are similar.² A detailed description of radiation protection can be found below in the NEP Interaction description.

The final environmental hazard is spacecraft charging. As a spacecraft becomes charged, the electrical conductivity can negatively effect the performance of all electronic equipment.

NEP INTERACTIONS

Basically there are two different sources of interaction with the spacecraft by the SP-100 system. Radiation from the nuclear reactor and effects of the propulsion system.

The SP-100 reactor produces both gamma and neutron radiation fluxes. Therefore in order to protect immediate equipment in the HTR, a shield must be present between the two systems. The shield is placed directly behind the reactor and consist of both gamma and a neutron shield. The shield is designed with tungsten as the gamma shield and beryllium as the neutron shield. Lithium-hydride separates the two shield since the materials are not compatible.^{2,4}

There are various interactions from the propulsion system that interfere with the spacecraft; 1) surface erosion, 2) film deposition, 3) plasma interactions, and 4) electromagnetic interference. Surfaces exposed to the thruster beam can be eroded. Erosion can cause failure in structural members and thermal control surfaces. The corrosive zone of the exhaust plume is typically 15° but could extend to a 40° maximum.² So in order to

prevent surface erosion the thrusters point away from all components and the HTR panels will not extend into the 40° cone of the thrusters. The deposition of propellant and non-propellant films on surfaces can cause a serious problem. Propellant and non-propellant sputtered from the thrusters may travel upstream due to diffusion and electromagnetic field effects. These films can alter electrical conductivity and impact antenna performance and thermal properties.² The propulsion system is not in danger of these effects because the temperature of these systems is too high to allow these particles to condense on their surfaces. To combat these effects, scientific equipment will be stored in the science and communications module and instruments such as the antenna will be blanketed for protection. The third propulsion interaction is plasma. Plasma generation can cause spacecraft charging and arcing. Circuit logic and breakdown of electrical insulation are results of plasma generation. These problems can be controlled by neutralizing the beam.² The final propulsion interaction, electromagnetic interference is produced by permanent magnets and dynamic electromagnetic fields. To prevent such interference, the thruster subsystem should be electrically isolated from other portions of the spacecraft.

SAFETY ISSUES

One of the key requirements of the Phoenix program is safety to Earth's population and environment. The SP-100 has been designed to remain intact and subcritical for a wide range of accident situations, including water immersion, flooding, burial, launch explosions, and reentry.

The unirradiated Uranium 235 fuel does not present a biological hazard. It can be handled and worked around without any special precautions. The reactor will remain unirradiated during ground and launch operations. The shielding around the core prevents the reactor from going critical in the

case of water flooding. And the core is honeycombed constructed with absorber rods that protect it from blast or impact. The SP-100 has also been designed with redundant shutdown mechanisms with two independent control systems. To prevent damage during any possible reentry, the nose cone of the reactor is designed with carbon/carbon composites which have demonstrated the ability to increase its strength as the temperature increases. One additional safety feature is that operation of the reactor will not occur until the spacecraft has reached nuclear safe orbit of 925 km. This orbit is high enough that radioactive elements will decay before its eminent reentry.

THERMAL CONTROL

One of the largest problems with the SP-100 is that it dissipates so much heat. For most spacecraft one would be concerned about keeping the various system equipment at a temperature that is warm enough for normal system operation. The SP-100 radiates 2.6 MWt at a radiator temperature of 800 K. heat flux at the radiator is $23,600 \text{ W/m}^2$ which is approximately 17 times the solar heating intensity. To avoid over heating of the science and communication module, at least 21 meters must separate the radiator and the module. (See figure 4).⁶ This separation reduces the incident heating on the spacecraft to 1400 W/m^2 . To help dissipate the heat into space a system of heatpipes and HTR panels are used. Titanium potassium heat pipes filled with lithium fluid located in the beryllium radiator panels accept heat directly from a source heat pipe assembly. For a detailed description of the heat transport subsystem see fig 5.³

CONCLUSION

To sum up, the Phoenix Pluto probe will should prove to satisfy the structural and thermal requirements described in the RFP. The over all

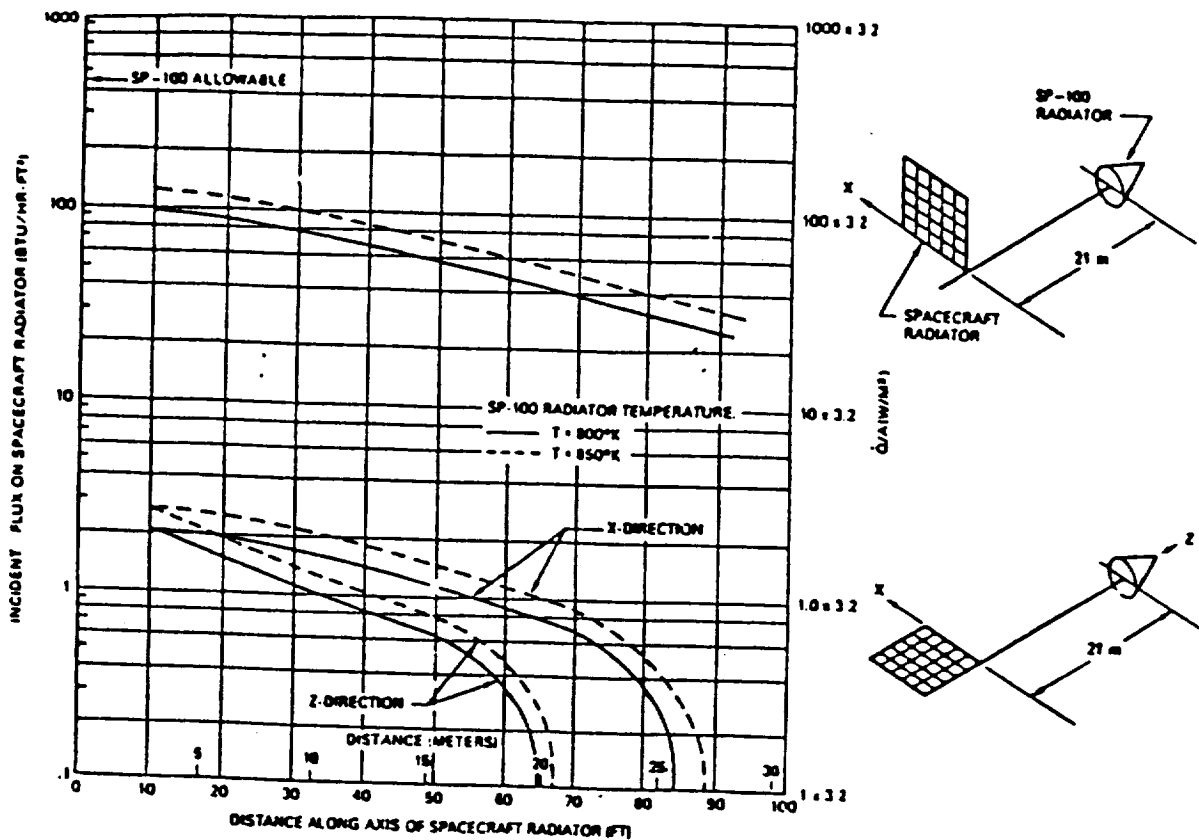

Fig. 4 Spacecraft heating environments from SP-100 radiators.

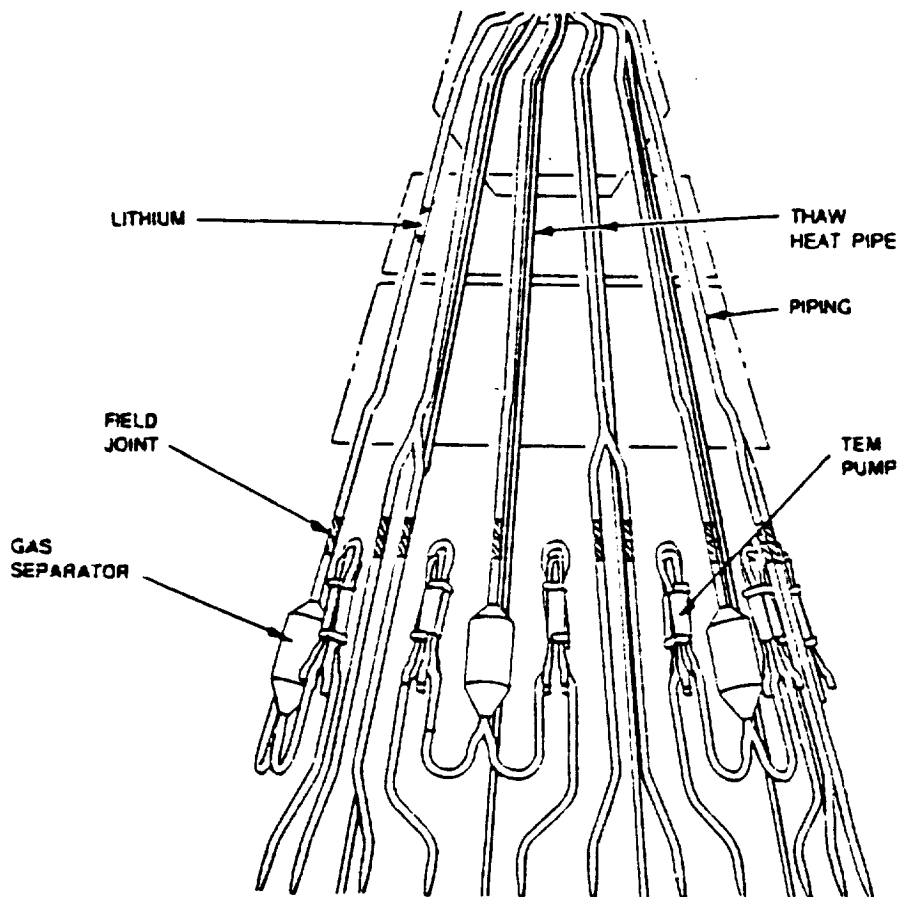

Fig. 5 Heat Transport Subsystem Components

ORIGINAL PAGE IS OF POOR QUALITY

configuration provides the ideal probe that is required to study Pluto. This is exemplified by the excellent field of view that the science and instrumentation will have. Further more, the SP -100 is the ideal method of thermal control. Not only does it provide ample heat, but also much valuable room on the payload module is saved since all thermal control control comes from the power module.

(16) *distances
radiation
environment*

APPENDIX

Equations

Mass Moments of inertia:

CONE

$$I_y = 3/10 (M1) (r1)^2 = 3(5928)(1.8)^2 = \underline{1778.4 \text{ kg m}^2}$$

$$I_x = I_z = 3/5 M1 (1/4 r1^2 + h^2) + M1 y^2 = 3/5(5928)[1/4(1.8)^2 + 5.8^2] + (1425)^2 = \underline{1.326E6 \text{ kg m}^2}$$

SPHERE

$$I_x = I_y = I_z = 2/5 M2 r2^2 = 2/5(16763.2)(.592)^2 = \underline{2349.95 \text{ kg m}^2}$$

CYLINDER

$$I_y = 1/2 M3 r3^2 = 1/2 (2223.12)(1.8)^2 = \underline{3601.45 \text{ kg m}^2}$$

$$I_x = I_z = 1/12 M3 (3r3^2 + L^2) + M3 y^2 = 1/12 (2223.12)[3(1.8)^2 + 5.3^2] + 2223.12(26.4) = \underline{65695.05 \text{ kgm}^2}$$

MASS INERTIA TOTALS

$$I_y = \underline{7729.8 \text{ kg m}^2}$$

$$I_x = I_z = \underline{1.394E6 \text{ kg m}^2}$$

References

1. Abraham, L. H., "Structural Design of Missiles and Spacecraft", McGraw-Hill Book Company, New York, 1962.
2. Buden, David and Garrison, P. W., "Space Nuclear Power System and the Design of the Nuclear Electric Propulsion OTV", AIAA Paper 84-1447, June 11 - 13, 1984.
3. Mondt, J.F., "Development Status of the SP -100 Power System", AIAA Paper 89-2591, July 10-12, 1989.
4. Harty, R.B., "A Comparison of the SNAP Aerospace Safety Program with Current Requirements", IECEC Paper 889244, 23rd IECEC Conference, 1988.
5. McConnell, V.P., "Advanced Composites Make a Case in Space", Advanced Composites, Sept./Oct. 1989.
6. Zafran, S., "Conceptual Arcjet System Design Considerations for the SP-100 Mission", AIAA Paper 89 - 2596, July 10-12, 1989.

Science Instrumentation

1.0 INTRODUCTION

It has been sixty years since a so called planet named Pluto has been discovered, and scientists still do not know exactly what it is. Existing theories state Pluto may well be a planet, but other theories argue that this mysterious entity may be an escaped moon of Neptune or a planetesimal. Basic quantities such as Pluto's albedo, diameter, and density are presently unknown. Scientists believe Pluto to be composed of rock, water-ice, methane-ice, and possibly argon. Charon, Pluto's only known satellite, is even more mysterious than Pluto. Without the knowledge of the above listed measurements, Pluto's and Charon's exact compositions can not be determined.¹ A spacecraft must be sent to the Plutoian system to determine this information. The PHOENIX orbiter, equip with many scientific instruments, is proposed to do so. Although the study of the Plutoian system is the main objective, another goal is to obtain valuable information about Jupiter, Mars, the asteroid belt, and any comet, asteroid, or body the mission may encounter during its planned journey.

Twelve scientific instruments will be used during the course of the Phoenix mission. Four are remote sensing instruments, six are fields and particles instruments, and one is a radio science instrument. The remote sensing instruments are of most importance to the Phoenix mission because they will be able to unlock many of the mysteries the Plutoian system holds. The fields and particles and radio science experiments will correlate information of this type received by previous missions. A detailed description of these instruments are found in part 3.

2.0 REQUEST FOR PROPOSAL(RFP) REQUIREMENTS AND COMPLIANCES

1.) RFP required an unmanned probe to Pluto:

PHOENIX mission complied by developing unmanned spacecraft.

2.) RFP required mission that maximizes information while minimizes cost:

PHOENIX complied by selecting an orbiter with a hope that a needle probe may be developed in time.

3.) RFP requires no materials or techniques after 1999:

PHOENIX Instrumentation Subsystem(PIB) complied by using all instruments with the exception of one which have previously been tested, approved, and used. The one instrument being built of existing technology, of new design, but of no breakthroughs in technology.

4.) RFP required sufficient shelf-life to satisfy mission plus a safety margin:

PHOENIX PIB complies with this demand.

5.) RFP requires mission to be able to perform several missions:

PHOENIX PIB complies with plans to study, Pluto, Charon, and any other planet, asteroid, comet, satellite the path of the mission allows.

3.0 SELECTION, JUSTIFICATION, AND POINTING REQUIREMENTS OF COMPONENTS

3.1 IMAGING SCIENCE SUBSYSTEM (ISS)

OBJECTIVES. The imaging science subsystem is clearly the most valuable scientific experiment carried by the PHOENIX orbiter. Scientists believe Pluto will have a thin or nonexistent atmosphere during the scheduled PHOENIX mission.¹ This will permit an excellent opportunity for an accurate determination of the morphology and geology of Pluto and Charon's surface. The ISS will also map spatial changes in color and albedo, and monitor the variations with time. Other objectives of the ISS will be to locate of the spin axes and rates of rotation of Pluto and Charon. The visual images obtained by the ISS will aid in relating data acquired by other remote sensors to certain features of the planet's surface.³

One of the advantages the PHOENIX orbiter offers over a fly-by mission is that the orbiter revolves around the Plutoian system allowing the entire system to be imaged. Also, the orbiter is able to get closer to the system's surface enabling it to take pictures of higher resolution.

When the opportunity arises, the PHOENIX orbiter will study the atmospheres and top cloud formations of other planets such as Jupiter or Mars. Other objects such as asteroids, satellites and comets will also be observed when encountered.²

INSTRUMENT. The imaging system used will be the system which is currently being developed for the Cassini mission. The imaging science subsystem consists of a narrow angle camera and a wide angle camera,

which share a common set of electronics. The system is based on a 1024 by 1024 pixel charge-coupled device. The ISS is comprised of the following subassemblies:

FILTER WHEEL - This is a two wheel selectable optical filter assembly containing twenty-two filters for the narrow angle camera and fourteen filters for the wide angle camera.

SHUTTER - A dual blade, focal plane, shutter design is used. No preparation is required before exposing an image. The shortest exposure time is five milliseconds. There is no upper limitation.

RADIATOR - Dark current will be subdued by the passive cooling of this radiator.

CCD - The format is 1024 by 1024 pixels, with each pixel size being 12 micrometers square. There are approximately 50,000 electrons in the partially inverted mode. The UV convertor lumogen phosphor.

OPTICS OF THE NARROW ANGLE CAMERA - The parameters of the narrow angle optics are: Ritchey Chretien with three field correctors; focal length of 2000 millimeters; focal ratio of $f/10.5$; spectral range of 200-11000 nanometers; resolution per pixel of 6×6 microradians; and field of view of 0.35 degrees square. The close-up lens in the filter wheel begin to fade out of focus at 3.8 km.

OPTICS OF THE WIDE ANGLE CAMERA - The parameters of the wide angle optics are: refractor in type; focal length of 250 millimeters; focal ratio of $f/4.0$; spectral range of 350-1100 nanometers; resolution per pixel 48×48 micro radians; and field of view of 2.8 degrees square.

Other subassemblies which will not be described here are: the detector head, square root processor, image data compressor, director and signal chain logic, and power supplies. For more information on these subassemblies see reference 4.

The ISS described described above is of new design, but, will be of

existing technology. If this design is not perfected by the time of the mission, the imaging system used on the Voyager mission shall be used instead.

The narrow angle camera, wide angle camera, and common electronics module will be mounted on the scan platform and inter-connected by shielded cables.⁴

3.2 NEAR - INFRARED MAPPING SPECTROMETER(NIMS)

OBJECTIVE. The main objective of this experiment is to investigate the near-infrared spectrum to determine the geology of Pluto and Charon. The experiment will also map and determine the mineral content of the surfaces of these bodies.

Pluto is believed to be composed of methane-ice, water-ice, and possibly argon, neon, and nitrogen. These molecules along with others will be specifically monitored by the NIMS. Other objectives of this experiment will be to probe the atmospheres and cloud layerings of Jupiter, Saturn, Mars, and any other objects with atmospheres when the opportunities arise.

INSTRUMENT. The NIMS was selected because it combines imaging and spectroscopic abilities in the same instrument. The telescope subassembly consists of an all- refractive telescope with a 22.9 cm aperture Ritchey Chretien. The focal length is 800 mm with an aperture of f/3.5.

The spectrometer subassembly consists of: a Dall-Kirkham type of collimator, a wide angle, flat field camera, and plane grating. The collimator has a focal length of 400 mm and a ratio of f/3.5. The camera's focal length is 200 mm, with a f/1.75 focal ratio. The grating is dual blazed, with 400 lines per mm.

The detectors (fifteen) are of the most sensitive type available, indium antimonide. They require cooling by a passive radiator to 80 K. Each of the 15 detectors is placed in different areas to sample specific regions of the spectrum. The NIMS is designed to measure wavelengths in the range of 0.7 to 5 micrometers.

The NIMS consumes an average of 8 w, and weighs 18 kg. The Galileo carried a NIMS of the above type. The NIMS will be positioned on the scan platform near the ISS. For more information on this instrument see reference 2.

3.3 PHOTOPOLARIMETER - RADIOMETER (PPR)

OBJECTIVE. The primary objective of the PPR experiment is to measure the polarization and intensity in the region of visible light (400-700 angstroms). This data will yield information about the properties of light-scattering surfaces.³

A second objective will be to measure the thermal radiation of Pluto and Charon. Another objective is to find the radiation budget of the Plutoian system by measuring the total thermal emission and reflective solar radiation.² The above stated objectives will also be applied to the atmospheres of Jupiter and any other planet with an atmosphere when encountered.

INSTRUMENT. The PPR used on the Galileo mission was the instrument selected to be carried by the PHOENIX mission. It was selected because of its dual abilities to measure photometry and infrared radiometry. The instrument is equipped with a Dall-Kirkham telescope with 10 cm aperture and a 50 cm focal point. This is the primary optical path of the subsystem. This optical path collects light and passes it through selected filters. This collected light is then measured by detectors.

There are two minor optical paths in the PPR. The first of these paths gathers radiation from the surveyed object. The other minor path collects radiation from space. These minor optical paths are used only in the radiometry mode of the instrument. Infrared channels in the radiometry mode are set below 4 micrometers, at 17, 21, 27.5 and 37 micrometer, and above 42 micrometers.

In the photopolarimetry mode, only radiation entering the primary optical path is emitted to the detectors. A beam is passed through a filter and enters in to a Wollaston prism. By rotating the filter wheel, the polarization of the transmitted beam rotated 90 degrees. This determine the orientation of the polarization of the incident beam. Polarimetry channels are centered at 4100, 6780, and 9450 angstroms. Photometry channels are centered at six positions between 6180-8920 angstroms.

The PPR subsystem has three important safety features: deployable covers which shield all optical when thrusters are fired, sunshades which prevent sunlight from directly entering, and replacement heaters which maintain the temperature when the power is turned off. The PPR subsystem weighs 4.8 kg, uses a peak power of 10 watts, and is mounted on the scan platform with the other remote sensing instruments.²

3.4 ULTRAVIOLET SPECTROMETER(UVS)

OBJECTIVE. The main objective of this experiment is to determine the structure and composition of the atmospheres of Pluto (if there is one), Charon, and any other satellite of Pluto which may exist. Atmospheric gases discharge radiation at ultraviolet wavelengths for two reasons. They are sometimes excited by bombardment with energetic particles, and sometimes the resonance dispersion of solar ultraviolet radiation cause this.³

Airglow will be analyzed by the UVS. The UVS will also determine

ultraviolet reflective properties of the surfaces of these bodies. This will yield information to help characterize surface materials and their physical state.²

INSTRUMENT. The PHOENIX mission selected an ultraviolet spectrometer similar to the instrument carried by Galileo. This instrument consists of a Cassegrain telescope (250 mm aperture), a monochromator, three detectors (photomultipliers), and control logic. The telescope is unique in that it can sample ultraviolet radiation coming from a small portion of the atmosphere or surface. The field of view produced by the spectrometer is 0.1 by 1.4 degrees for 1100-1900 and 2800-4300 angstrom detectors and 0.1 by 0.4 degrees for the 1600-3000 angstrom detector. The monochromator has a focal length of 125 mm.

A programmable grating drive which is regulated by the control logic controls the wavelength of the radiation being measured. The grating supplies a resolution of 13 angstroms in the first order spectrum and 7 angstroms in the second order spectrum. The photomultipliers are capable of investigating wavelengths from 1150-4300 angstroms. Photon pulses are counted every 0.0007 seconds. This UVS was selected because of its wide range of spectra (1150-4300 A^o) and its flexibility in variety of data taking programs.²

The UVS subsystem weighs 5.21 kg, and consumes 5.33 W at 2.4 kHz and 50 Vac. It is secured on the scan platform with the previous three instruments.²

* NOTE: No direct sunlight can enter any of the remote sensing instruments. All instruments shall be equip with shields to block the sun.

3.5 MAGNETOMETER SUBSYSTEM(MAS)

OBJECTIVE. Interplanetary space is traveled by the solar wind, streams

of charged particles, and shifting magnetic fields that the solar winds bring with them. Some planets have their own magnetic fields. The main objective of this experiment is to determine if Pluto and Charon possess magnetic fields. The second objective is to investigate interactions between Pluto's and Charon's magnetospheres, if any exist.

The magnetometer experiment will also acquire data on all other magnetic fields encountered during the Phoenix mission. This data will be used in comparative studies with data received from other fields and particles instruments.

INSTRUMENT. The magnetometer subsystem consists of four subassemblies; two high field magnetometers (HFM), which measure $\pm 0.5G$ to $\pm 20G$, and two low field magnetometers (LFM), which measure ± 8.8 gamma to $\pm 50,000$ gamma. The Phoenix orbiter does not spin, therefore the type of magnetometer that was carried on the Voyager mission will be used.

Each of the four subassemblies consist of triaxle fluxgate magnetometers that measure field and intensity along three orthogonal axes simultaneously; thus, producing direct vector measurements. One LFM is placed at the middle of the boom (0.80 kg), and the other is placed at the end(0.75 kg). This arrangement will allow the spacecraft's magnetic field to be separated from the ambient magnetic field. In doing this, accurate information can be obtained. Both HFMs are placed near eachother, at the proximal end of the boom (0.26 kg each). The total mass of the MAS is 5.72 kg.³

3.6 ENERGETIC PARTICLES DETECTOR(EPD)

OBJECTIVE. The main objective of this experiment is to investigate the temporal fluctuations and spatial disbursement of ions and electrons in the

medium to high energy range (0.015 to 0.2 MeV and 0.1 to 1.0 MeV respectively). This experiment will be performed in the Plutoian system, interplanetary space, and other systems when encountered.

INSTRUMENT. The EPD has two bidirectional detector telescopes which are mounted on a platform in the spun instrument section. The telescopes used are a low-energy magnetosphere measuring system (LEMMS) and a composition measuring system (CMS). The LEMMS includes an ion telescope, two detectors, and a magnetic electron spectrometer. The energies measured by this subassembly are .015 to 0.2 MeV and 0.1 to 1.0 MeV. The CMS is comprised of a three-parameter detector system consisting of nine detectors. These detectors measure the energy spectra, composition, and pitch angle distributions of energetic ions in the Plutoian system. The EPD subsystem has a total mass of 10.77 kg and is located on the spun instrument section.²

3.7 PLASMA SUBSYSTEM(PLS)

OBJECTIVE. Plasma is gas found in space that is electrically neutral, but, composed of charged particles. The main objective of the PLS experiment is to measure plasmas velocity, density, and pressure. PLS instrument also determines the plasma flow direction by measuring the variation velocity with direction.

INSTRUMENT. The PLS subsystem used on Galileo was selected over the PLS subsystem used on the Voyager for the following reasons. First, it has an extended energy range of 1.2-50,400v; where as the Voyager PLS had a range of 10-5920v. Second, it has three miniature mass spectrometers which analyze ion compositions, while Voyager had none. Finally, while Voyager's PLS had a temporal resolution of 100 seconds, Galileo's PLS has a temporal resolution of 5 seconds.^{2,3}

3.8 PLASMA WAVE SENSOR(PWS)

OBJECTIVE. The objective of this instrument is to identify and analyze the radio and plasma waves in Pluto's magnetosphere. The PWS is equipped with the capability of remote sensing of source location. Magnetospheres of other planets and satellites will be studied when opportunities arise.

INSTRUMENT. The PWS consists of an electric dipole antenna for the detection of electric fields and two coil magnetic antennas for the detection of magnetic fields. These subassemblies measure spectral characteristics of electric and magnetic fields in the range of 5 Hz to 5.65 MHz. The total mass of the PWS is 7.22 kg. The antennas are located at the end of the magnetometer boom on the vertical axis. ³

3.9 DUST DETECTOR SUBSYSTEM(DDS)

OBJECTIVE. The dust detector experiment will aid in the understanding of physical and dynamic properties of small dust particles in the Plutoian system. This information will help answer questions about the existence of Charon, which is thought by some to be a fragmented piece of Pluto.

INSTRUMENT. The DDS is comprised of a set of grids that sense the impacts of dust particles. The instrument's field of view is 140 degrees. It can measure masses in the range of 10^{-19} to 10^{-9} kg and velocities in the range of 2 to 50 km. The DDS measures 0.1 by 0.1 m, weighs 4.37 kg and is placed on the spun instrument section to determine the flight direction of the particles.²

3.10 MICROMETEOROID DETECTOR(MMD)

OBJECTIVE. Micrometeoroids are particles smaller than one mm in

diameter that are present in the space occupied by our solar system.

Although the Voyager mission took no particular notice to the asteroid belt due to the results of the Pioneer 10 and 11 (no concentration within the belt), the Phoenix mission will carry a micrometeoroid detector (MMD) to study the belt and verify Pioneer's findings.

A second reason for employing this instrument is to study the Plutoian region for these particles. A knowledge of the micrometeoroids present in this area may unlock some of the mystery of the being of Charon. It may give some clues as to if Charon is a fragmented piece of Pluto.

INSTRUMENT. The MMD used on the Phoenix mission is similar to the instrument used on the Mariner-Mars spacecraft. A crystal acoustical transducer is fastened to aluminum plates (22 cm by 22 cm). The crystal will discharge an electrical pulse whenever a micrometeoroid strikes the plate. The plate is completely covered with an insulating and conducting film. This forms a capacitor sort of detector. A potential is placed across this capacitor and an electrical discharge occurs when a micrometeoroid perforates the insulation of capacitor. This type of capacitor detector is self repairing and is excellent for repeated use. When the capacitor detector output coincides with the output of the acoustic detector, the direction of the micrometeoroid can be determined. The present design of the MMD allows for the determination of the number and penetration power of the micrometeoroids.

New MMDs which will calculate velocity as well as momentum may be available before the Phoenix is built. This advanced instrument will be used in place of the above described MMD if so.⁵

3.11 RADIO SCIENCE SUBSYSTEM(RSS)

OBJECTIVE. Two experiments, celestial mechanics and radio propagation, will be investigated by the radio subsystem. The celestial mechanics experiment will be used to determine the structures and shapes of the gravitational fields of Pluto and Charon. This subsystem uses the radio system to perceive gravitational perturbations on its trajectory.

A primary goal of the radio propagation experiment is to study ionospheres, atmospheres, and magnetospheres. This will provide measurements of density, pressure, and temperature as a function of height; which is dependent on the doppler shift. While not as important for the probing of Pluto, the experiment will be more essential for the studies of planets with atmospheres.

INSTRUMENT. The radio frequency subsystem is used in combination with receivers and transmitters based on earth. The RFS measures doppler shifts, echo time delays, amplitude, spectrum and polarization of radio signals. The mass, size, and location of this assembly can be located in the Command, Control, and Communications subsystem. ²

References

- 1.) **Croswell, Ken; "Pluto: Enigma on the Edge of the Solar System",
Astronomy; July, 1986; pg. 8-22.**

- 2.) **National Aeronautics And Space Administration, Washington D. C.;
Galileo: Exploration of Jupiter's System; NASA SP 479, pg. 119-141;
1985.**

- 3.) **NASA Jet Propulsion Laboratory, California Institute of Technology;
"Voyager Neptune / Interstellar Mission: Flight Science Office
Science and Mission Systems Handbook"; JPL D-498, PD 618-128, pg.
1-52; October 1, 1987.**

- 4.) **NASA Jet Propulsion Laboratory, California Institute of Technology;
"Cassini Mission: Saturn Orbiter Proposal Information Package,
Volume VI: Imaging Science Subsystem Description"; JPL D-6464, PD
699-11, Vol. VI; October 10, 1989.**

- 5.) **NASA, Auburn Alabama; "JOVE: Jupiter Orbiting Vehicle for
Exploration. Volume 1", pg. 3.1-3.47; NSR 01-003-025,
CR-61880; August, 1967.**

ATTITUDE AND ARTICULATION CONTROL SYSTEM

The goals of the attitude and articulation control system (AACS) are to achieve and maintain a particular orientation in space. The first phase of this process is attitude acquisition which employs a variety of sensors to locate the spacecraft in space relative to some inertial reference frame. Stabilization of the craft in this orientation is maintained through the use of control actuators which must also be capable of maneuvering the spacecraft from one attitude to another.⁴ The selection of the AACS methods and hardware depend on the mission requirements, with special care taken to insure compatibility and integration with the other subsystems.

AACS REQUIREMENTS

Table 1 outlines the specified and derived requirements pertaining to the AACS , and provides a reference location of compliance for each requirement. The primary requirements of the AACS are to survive the long life of the mission and be capable of several different missions. The first of these leads to the derived requirement of total redundancy of all systems, while the mission flexibility requirement calls for a reliable system of control actuation. Also the fifteen-plus year life of the mission dictates the need for autonomous control. An increasing communication delay time as the spacecraft moves further away from earth and periods of no communications require an on-board system capable of analyzing attitude acquisition information and implementing control actuation to maintain spacecraft stabilization without the benefit of command. This is accomplished with advanced software on-board with preprogrammed actuation sequences to accommodate all

AACS REQUIREMENTS

Table 1

SPECIFIED REQUIREMENTS (R.F.P)

1. Optimize performance, weight, and costs in design trades.
2. Design must be reliable, low cost, simple, and easy to operate.
3. Use "off the shelf" hardware developed before 1999, when available.
5. System should have a sufficient lifetime plus a safety margin.
6. Must be an original and imaginative design.
7. Identify the design approach and technical problems.
8. Probe must be capable of several missions.

DERIVED REQUIREMENTS

1. Maintain antenna and science instrument pointing
2. Select a stabilization method.
3. Select types and placement of sensors and actuators.
4. Integrate the AACS with other subsystems.
5. Determine torque and momentum requirements.
6. Must have partial autonomous control capability.
7. Determine environmental effects.
8. Must have a fifteen year minimum lifetime.
9. Total redundancy of all systems

conceivable maneuvering scenarios.

Further requirements of the AACS are dictated by the basic structural configuration of the flight vehicle. For instance the dumbbell type configuration selected for the final design must be Three-axis stabilized. Spinning the vehicle about the pitch axis (x-axis) or the thrust vector (z-axis) would result in poor communication capability since the antenna must be placed at the far end of the spacecraft to avoid adverse interaction with the nuclear propulsion system. Spinning about the roll axis (y-axis) would result in an unstable spin which would eventually lead to an undesirable end over end rotation about the pitch axis (x-axis). All other requirements are dependent upon AACS component selection and placement and are discussed throughout the report.

DESIGN APPROACH

The method of attack for selecting the AACS is basically a design by design approach. Following a considerable amount of initial research, several spacecraft and AACS configurations are selected with input from the other subsystem analysts. These preliminary design choices are then analyzed to determine if they satisfy the real and implied requirements of the mission. All problems with the selected systems are then outlined and further research is done to determine possible solutions to these problems. Finally the options are compared and a final configuration is selected. The remaining analysis consists of refining the best choice and presenting the final design.

DESIGN TRADES

The first design trades considered are low cost versus reliability, long life, and accuracy. This cost pertains to both weight and monetary cost and is a factor in the selection of the AACS hardware. Another important

trade related to hardware selection is an original design versus "off the shelf" hardware. Newer components may be technically superior but previously space tested hardware has the overwhelming advantage of known performance parameters, which reflects the use of tested components in the final design configuration. Other trades relative to the final design include maneuverability versus disturbance sensitivity and reaction wheel versus thruster control in terms of stabilization capability and fuel consumption.

INITIAL CONFIGURATIONS

Three different spacecraft and AACS configurations were selected for the preliminary design analysis.

They include:

1. Spin stabilized spacecraft - Chemical propulsion, RTG power.
2. Spin stabilized spacecraft - Nuclear electric powered upper stage.
3. Three-axis stabilized spacecraft - Nuclear electric propulsion, two on-board reactors.

The first choice is a Pioneer type scientific probe with hardware modifications made to fulfill the mission requirements, such as long life. This configuration was rejected without further research due to its incompatibility with the nuclear electric propulsion (NEP) system selected by the the design team.

The second spacecraft configuration utilizes Three-axis stabilization throughout the initial thrust phase of the mission, which is limited by the assumed ten year life of the NEP system. At this time the entire NEP system is jettisoned and a spin stabilized scientific probe continues on to Pluto powered by RTG's. The advantage of this particular configuration is

that the NEP upper stage can deliver a larger payload Through the initial delta-v required than a weight comparable chemical upper stage.¹ Also, following the NEP system detachment, the scientific probe would only require a five year power active lifetime, assuming a fifteen year mission. Disadvantages of this selection include a large launch mass and a loss in simplicity of design. This configuration would would require two independent control systems, one for the three-axis control of the primary vehicle and another for the spin stabilized craft. Also a large change in the mass of the vehicle following the NEP system detachment would require a complex control scheme to maintain stability. These drawbacks and the resulting high monetary cost of such a mission do not satisfy the specified mission requirements.

FINAL DESIGN CONFIGURATION

The third preliminary configuration was selected as the final design on the basis of mission requirement compatibility and a favorable analysis of the design trades. A layout of the spacecraft including locations of the AACS components is shown in figure 1. The vehicle consists of two nuclear reactors, a power conditioning unit, and heat shielding at one end, and the scientific payload and C³ hardware at the opposite end. The spherical fuel tank is located directly below the main thruster block, both of which are positioned at the vehicle center of mass. As discussed earlier, three-axis stabilization is the only viable control method for this dumbbell type configuration due to the requirements of maintaining adequate communication capability while avoiding adverse interaction with the NEP system. Furthermore, a flexible system utilizing active control is desirable to counteract the effects of structural vibrations within the 28.5 meter extendible boom.⁵

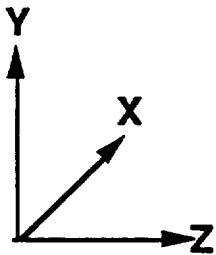
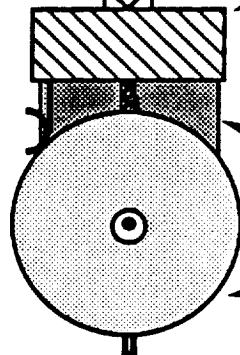
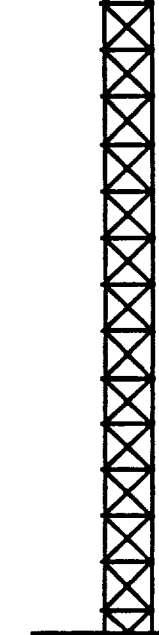
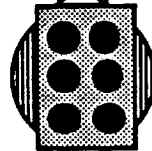
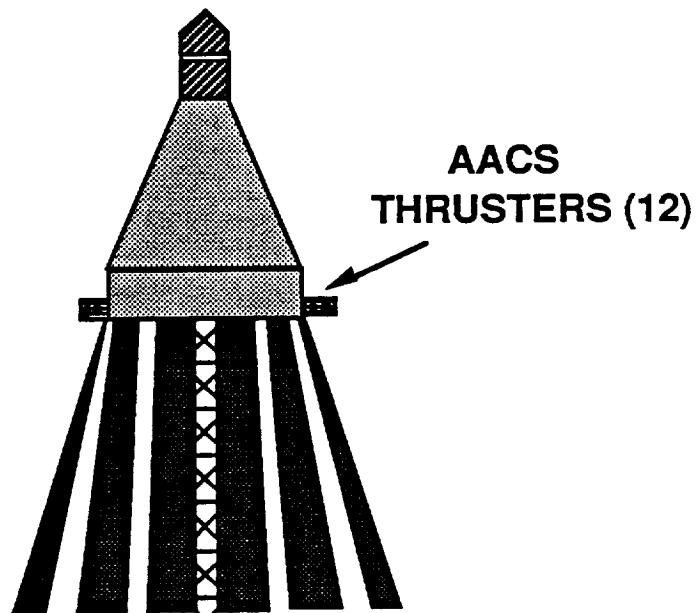

AACS
THRUSTERS (12)

AACS control
cylinder
(Gyros, wheels)

2-axis
sun sensor (2)

Star sensor
assembly

The three-axis active control system offers the advantage of inertial stabilization with the potential for high pointing accuracy. It is the best method for maneuvering which allows for high precision and adaptability to perform several different missions. A disadvantage of the system is that six possible control directions (pitch, roll, and yaw) must be maintained. Also a two-axis sun sensor is required due to the absence of rotation.

CONTROL MODES

The control modes for the various phases of the mission are:

1. Attitude acquisition mode
2. Cruise mode
3. Trim maneuver mode
4. Orbit insertion mode
5. Large maneuver mode

The first three modes rely primarily on sensor information and low maneuvering thrust, while the last two Require both sensor information and considerable auxiliary propulsion. Further analysis of the control modes is discussed in terms of AACS hardware selection and performance in the following section.

AACS HARDWARE

To fulfill the requirements of long mission life, pointing accuracy, and total redundancy a dual control actuation system was selected. The system includes twelve .005 newton thrust mercury ion thrusters (4 on each axis with 6 in operation and 6 redundant), and a reaction wheel assembly. Figure 2 shows an operating schematic of the system. During the initial attitude acquisition phase of the mission both systems will be

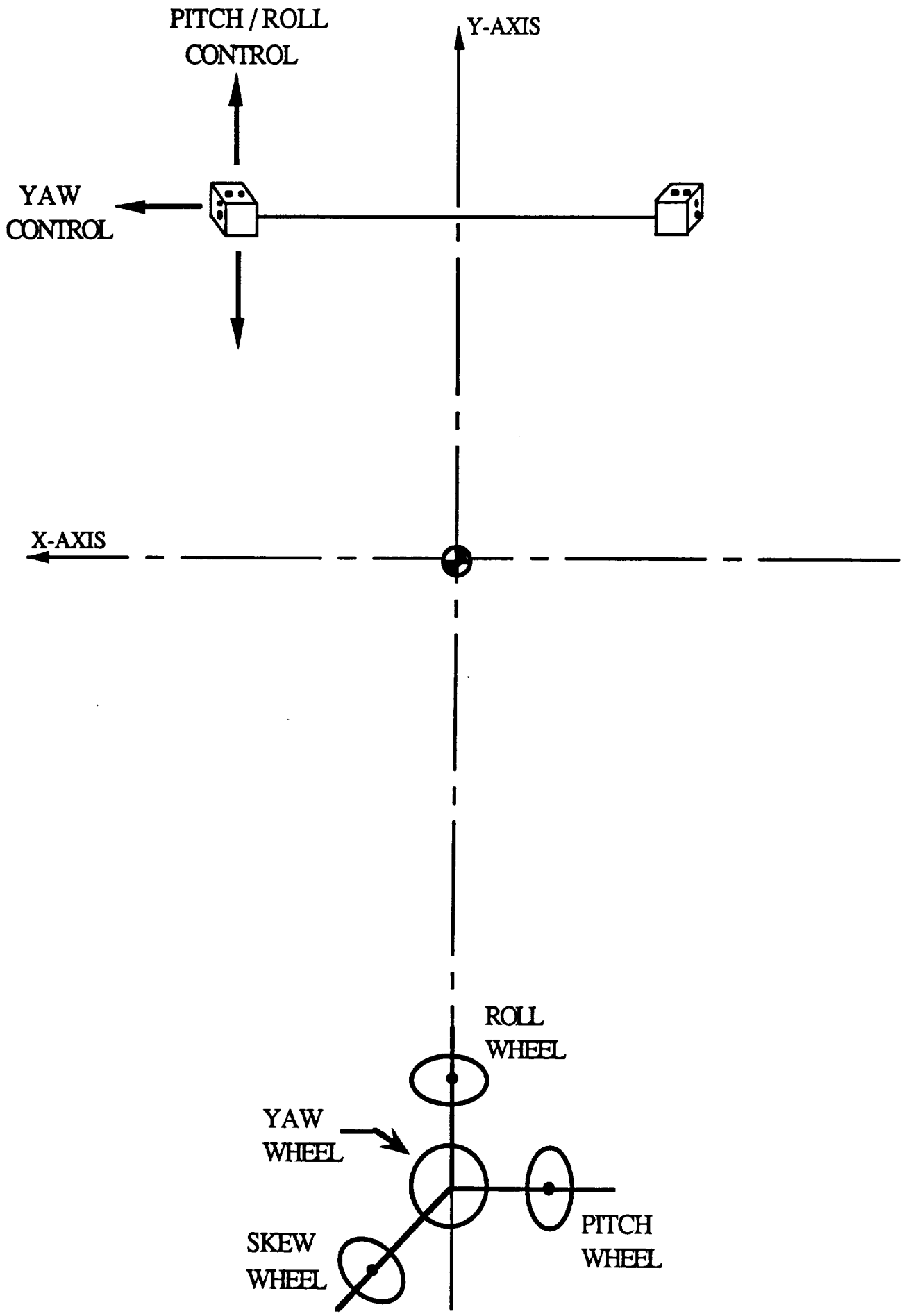

used to increase the spacecraft maneuverability. Throughout the 12-14 year cruise phase The reaction wheel assembly will provide primary control actuation, with the thrusters used for momentum desaturation and trim maneuvers. The final stage of the mission requires fine pointing of the science instrumentation and the antenna, which is control by the more stable reaction wheel assembly. Again the thrusters could extend maneuverability or take over primary actuation if necessary. This configuration satisfies the reliability requirement through total redundancy, and minimizes the auxiliary propulsion fuel usage during the cruise phase while maximizing maneuvering capability throughout the mission.

The attitude acquisition system includes a pair of two-axis sun sensors mounted on either side of the payload platform, which provides a 4π steradian view. A celestial sensor assembly utilizing six detector slits in a spoke configuration is mounted at the far end of the payload platform to allow an unobstructed field of view for continuous star reference. Also, an inertial measurement unit containing three rate integrating gyros (2 for three redundancy) is located in the AACS cylinder centered along the y-axis of the spacecraft, which provides displacement information through rate integration to the control computer.² Figure 4 shows the location of the attitude acquisition system on the payload platform and table 2 describes the AACS components and gives the total AACS mass.

All selected hardware has been space tested, particularly in the Defense Meteorological Satellite Program Which satisfies the "off the shelf" requirement.² Also the system is capable of switching attitude acquisition responsibilities to different sensor configurations in the event of a component malfunction, which provides for total system redundancy.

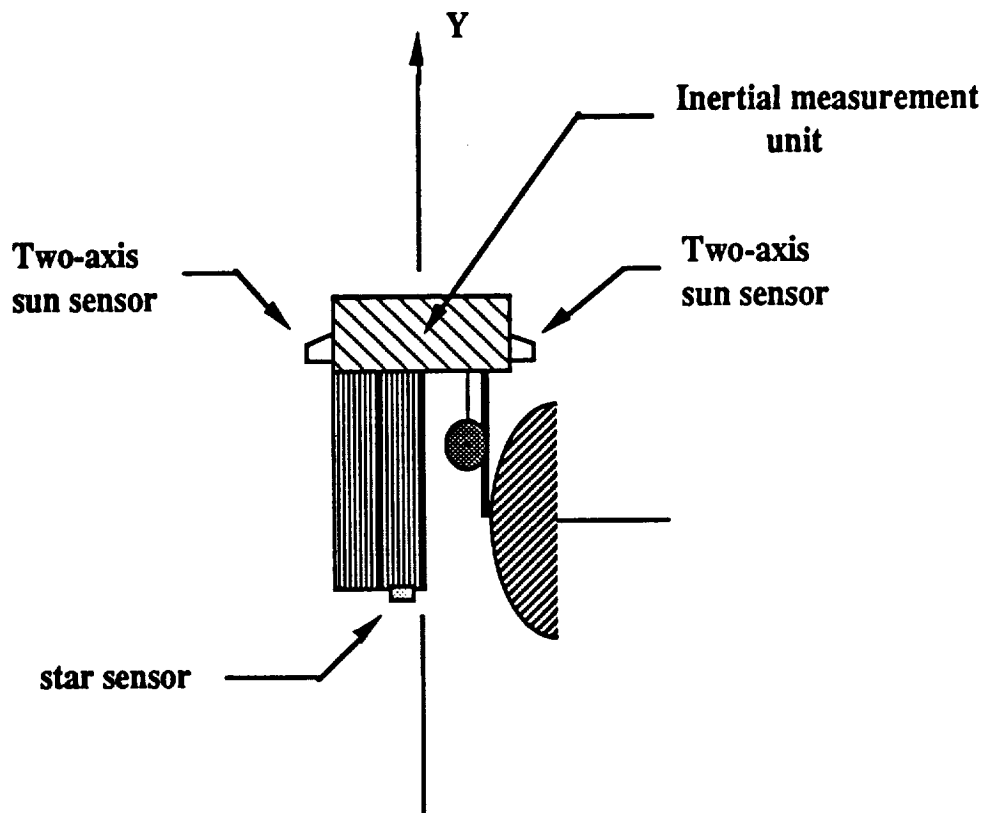

Figure 4
Sensor placement

AACS HARDWARE DESCRIPTION

Table 2

1. Inertial measurement unit: (Honeywell)	56.0 W	15.0 Kg
2. Sun Sensor (2) (SAGE,HCMM)	3.0 W	1.6 Kg
3. Star Sensor Assembly (Honeywell)	1.5 W	4.3 Kg
4. Reaction Wheel Assembly (4) (RCA AED)	16.0 W	25.6 Kg
5. Mercury Ion Thrusters (12) ----Included in propulsion subsystem-----		
TOTALS	76.5 W	46.5 Kg

SYSTEM INTEGRATION

A primary requirement of the AACS is integration with the other subsystems. The science and communication subsystems both rely heavily on the the AACS for antenna and instrument pointing. Antenna pointing accuracy must be in the range of .5 to 10.0 degrees, while instrument pointing requires an accuracy range of .35 to 2.0 degrees. The three-axis stabilized design meets the requirements with a pointing capability of .001 to 1.0 degrees depending on selection of and condition of the sensors. Sun shielding is another important concern of the science subsystem during the early phase of the mission. The initial solution to this problem was to orient the spacecraft such that the antenna would shield the instruments, but this approach was rejected in favor of enclosing the sun sensitive instruments in a hinged shield box when not in use. Finally the configuration must be such that the center of mass does not change as fuel is expended. To avoid this problem the spherical fuel tank is located directly on the y-component of the vehicle center of mass.

DESIGN PROBLEMS

External and internal torques on the spacecraft can cause undesirable structural stresses and changes in attitude if not counteracted. The three-axis active control system is particularly sensitive to environmental disturbances such as meteoroid bombardment and solar radiation. Also impingement forces from the ion plume effects and internal torques due to actuator operation tend to take the spacecraft out of a stable configuration. The spacecraft will oppose these disturbance forces with occasional trim maneuvers to return the vehicle to the desired orientation.

Another problem imposed by the long mission life is gyro drift. To correct this deviation the star sensor is used to obtain an exact position

from the last best position estimate from the gyro. This correction is returned to the gyro and actuation is implemented if necessary.⁴ Other problems encountered include the required life of the AACS components, which is satisfied by total system redundancy, and mercury contamination of the sensor surfaces from the main thrusters, which is minimized as the distance between these areas increases. The more sensitive instruments require shielding which is accomplished with the enclosed science box and small shields above (towards the propulsion section) the star and sun sensors.

DISCUSSION

The final design selection meets all of the specified and implied AACS requirements, and should provide an excellent attitude acquisition and maneuvering system for a mission of this type. The mission is limited only by the lifetime of the system hardware, which should increase in the future. The AACS is particularly effective for spacecraft maneuverability which is necessary to fulfill several different missions. Future research should focus on improved autonomous control capability, the radiation effects on C³ and science systems, and long life reactors capable of powering a spacecraft for ten or twenty plus years.

REFERENCES

1. Deninger, W.D., "Electric Propulsion for Constellation Deployment and Spacecraft Maneuvering", AIAA Paper 88-2833, July 11-13, 1988.
2. Cheng, G.J., "The Mars Observer: Attitude and Articulation control system", AAS Paper 88-001, Sept., 1988.
3. Ninomiya, Keiken and Inoue, Hajime, "In-Orbit Control of Astro-C Satellite (1987-012A) Attitude Control System", AAS Paper 88-051, Sept., 1988.
4. Wertz, James R., "Spacecraft Attitude and Articulation Control", Reidel Publishing Company, 1988.
5. Zafran, S., "Conceptual Arcjet System Design Considerations for the SP-100 Mission", AIAA Paper 89-2596, July 10-12, 1989.

PROPULSION AND POWER

A.) REQUIREMENTS

B.) METHOD OF ATTACK

C.) SYSTEM

1.) PRIMARY THRUSTERS

a.) POSSIBLE THRUSTERS

b.) THRUSTER SELECTED

c.) PROPELLANT

d.) ION DYNAMICS

e.) SPECIFICATIONS

2.) ATTITUDE AND ARTICULATION THRUSTERS

3.) POWER SOURCE

4.) INTERACTIONS WITH OTHER SUBSYSTEMS

D.) PROBLEMS

E.) EQUATIONS

F.) REFERENCES

A.) REQUIREMENTS

- 1.) Should use off the shelf hardware, nothing which has not been developed by 1999.
- 2.) Must be ready before 2010.
- 3.) Should optimize performance, weight, and cost.
 - 4.) Should be reliable and easy to operate.
- 5.) Must be able to withstand any environment it may encounter.
- 6.) Must have a design lifetime to carry out its mission plus a reasonable safety factor.
- 7.) Nothing in the design should preclude it from performing several possible missions.
- 8.) Design will stress simplicity, reliability, and low cost.
- 9.) Exceptions to proposed technical requirements should be identified and justified.
- 10.) Primary thrusters must be able to deliver to Plutoian Orbit.
- 12.) Propulsion and Power subsystems must not interfere with other subsystems.
- 13.) Power subsystem must be able to deliver the power required by all other subsystems at any given moment.

B.) METHOD OF ATTACK

The general process that I followed when I was designing the various components of the propulsion and power subsystem is what I call my method of attack. The first thing was to develop a fundamental

understanding of various types of possibilities for a given component. Next, I evaluated the pros and cons of each candidate for that component, and how they related to the needs and objectives of the mission. By process of elimination, I then determined which candidates may be realizable. Next, I investigated the realizable candidates in depth, and determined which one is most suitable for the given mission. Finally, I continued to develop, and address problems related to the candidate decided upon until the final design is complete.

C.) SYSTEM

1.) PRIMARY THRUSTERS

In determining the type of primary thrusters, several factors were considered. First, the system should make efficient use of its propellant. The common measure of propellant efficiency is specific impulse(Isp) which is defined as the ratio of thrust to mass flow rate of propellant. Thrusters with high values of Isp have high exhaust velocities which translates to a high amount of energy in their exhaust streams. This allows such thrusters to move a more massive payload with less propellant. The second factor is thrust. Systems with higher values of thrust will be able to make journeys in less time for a given type of trajectory, either low thrust or impulsive. In addition, systems with high enough thrust to use impulsive velocity change trajectories have the benefit that their trajectories are computationally much simpler than low thrust trajectories. The third factor is the ease and cost of producing the system. In expensive systems which have been or can easily be developed

and tested are preferred. The fourth factor is additional mass associated with the system. Though a system may use its propellant efficiently, the associated mass may make the system as a whole inefficient compared with other options.

a.) POSSIBLE THRUSTERS

The first type of thruster considered is the chemical rocket. Solid chemical rockets have high thrust, but low Isp. In addition they cannot be throttled. Certain liquid propellants have an adequately high Isp to be used as a primary thruster on a journey of this length. However, the mass of the payload would be limited. Both solid and liquid chemical rockets have the benefit that they have already been developed, and flight proven many times.

The second type of thruster is the electrically propelled rocket. This includes electrothermal, electrostatic, and electromagnetic thrusters. These types of thrusters are capable of attaining very high values of Isp, but generally have low values of thrust. One drawback to this type of propulsion is that it has not really been researched on an interplanetary scale. Another drawback is that electric methods of propulsion require large amounts of power. This power requirement has an associated mass which is large with respect to the rest of the system.

The third type of thruster is the nuclear rocket. Performance of nuclear rockets is limited by the fact that there is a limit on the maximum solid surface temperature that the reactor must operate within to ensure structural integrity. Thus, unlike the condition found in a

chemical rocket where the energy release is within the propellant, the propellant temperature in nuclear rockets is restricted to being less than the wall temperatures, and hence less than that found within chemical rockets. Another drawback is that since the propellant passes directly through the core of the reactor, the exhaust stream is contaminated. Nuclear rockets also have additional associated mass penalties which come from the reactor.

The fourth type of thruster type is cold gas. This is simply the thermodynamic expansion of a cold gas. Cold gas thrusters have low values of I_{sp} , but are reliable and have been flight proven many times.

Other types of thrusters are solar, and laser. Solar propulsion is ineffective at the great distances from the sun that will be characteristic of this mission. Laser thrusters, as of yet are not developed.(ref. 1,2,3,5)

b.) THRUSTER SELECTED

Upon evaluating the options, I decided to use an electrostatic thruster on the Phoenix probe. During 1980, Studies at the Jet Propulsion Lab focused on the application of nuclear electric propulsion (NEP) to outer planet missions. The study concluded that NEP was much better than other competitive technologies, and that a 100 kw (electric) system significantly out performed chemical propulsion systems for outer planet exploration.(ref. 2)

Since NEP has not been developed, In reality, It would be the case that many additional dollars would have to be spent on research, development and testing for this mission. This would make it very

unappealing as the best method for the mission. However, as stated in class by teaching assistant Andy Koepke, for this project, it may be assumed that the technology has already been developed, and that costs affiliated with research and development may be neglected.

The additional mass associated with the power system needed makes the benefits of this type of propulsion system unclear when the payload mass is small compared to the power system mass. In fact it is possible that the propellant mass for the Phoenix probe may even be higher than that for analogous chemically propelled missions. However the the real benefits of NEP comes from the fact that once the mass of the power subsystem is fixed, the marginal or additional amount of propellant required for a given marginal payload mass will be much less than that for a chemically propelled system. Since the RFP states that the system should be capable of performing several types of missions, it is very important that the system should have a capacity for a marginal payload. Also with the capability of taking greater payload masses to a destination also comes the capacity for designing better science experiments which would not be realizable with chemical propulsion. Though at its present status the phoenix mission may not appear to be the best choice in terms of money, it has the capacity of having added to it some very advanced science experiments, including possibly a lander, before its launch date. In addition, information gained on NEP from this mission will be very beneficial to future high energy deep space missions where propellant efficiency is crucial.

c.) PROPELLANT

Determination of propellant is based on several factors. First, the

propellant should have a high nuclear mass, and a low ionization potential. This is because the beam thrust is proportional to the square of the mass to charge ratio. Second, the propellant should be easily stored. This is especially important on missions of comparable duration to that of the Phoenix mission. Third, the propellant should be environmentally safe, non corrosive, and have minimal effects on other subsystems. Fourth, the propellant should yield a high thruster efficiency. (ref. 1,2,5)

One possible propellant is cesium. Cesium has a high mass to charge ratio, but is highly corrosive. Thus, it would be hazardous to both the environment as well as the other subsystems. Another possible propellant is xenon. Xenon is environmentally safe, and easily stored. However, it is expensive and rare. In fact there may not be enough currently available to make this one trip. Though xenon is a prime candidate for earth orbital transfers, there is simply not enough to make it practical for missions comparable in length to the Phoenix Mission. Another inert gas which could be used is argon. Argon is also environmentally safe, but is difficult to store. In addition, argon is more abundant than xenon. The final propellant considered was mercury. Mercury yields the highest thruster efficiency of those propellants considered. In addition, it is easily stored. The main problem with mercury is that it is poisonous. Since only a small fraction of the mission will be spent near the earth's atmosphere, environmental contamination is not a big problem.(ref. 2) This coupled with the fact that it best satisfies the guidelines used to evaluate the various propellants, makes mercury the propellant selected.

The sizing of the propellant tank was done by starting with the assumed value for the total mass of the mercury required which is about 12,000 kg. Next, the density of mercury was obtained, and turned out to be 13,800 kg/m³. The volume required to contain the mercury was then

computed by dividing mass by density. This gave a propellant volume of 0.87 cubic meters. Since a sphere is structurally more sound than a cube, the propellant will be contained in spherical tank of radius 0.592 meters.

c.) ION DYNAMICS

The method which will be used to generate ions will be electron bombardment. The neutral mercury or plasma, will be passed through a cylindrical anode. Surrounding the cylindrical anode will be a solenoidal coil which will be used to generate an induced magnetic field in the direction of the plasma flow. At the center of the cylindrical anode will be a heated filament cathode which will be the source of electrons. The filament will be heated by passing an electrical current through it. As a result, the heated filament will bleed of electrons. The free electrons will be accelerated radially outward by the cylindrical anode. The presence of the magnetic field will give a tangential force acting on the electrons making them spiral outward toward the anode, increasing the likelihood of them hitting a mercury atom before they reach the anode. The collision between the electron and the neutral mercury atom will produce the ion.

Once the ions are produced, they will then be subjected to an electrostatic potential difference. They will be accelerated toward an electrode which is at a lower potential. When the ions reach the accelerating electrode, they will be at their minimum potential, and have their maximum kinetic energy. As their momentum carries them past the electrode, they will be accelerated back towards that electrode, and will begin to lose their kinetic energy. Therefore it is necessary to recombine the ion stream with an electron stream in order for the ions to retain

their momentum. Ideally one would want to recombine the ion stream with electrons at the point of lowest potential. However, trying to do so will result in the electrons diffusing into the acceleration field. Thus, there is an optimal distance from the electrode that the electron stream should be recombined with the ion stream. I, however am unable to compute this optimal distance. The electron stream used to neutralize the ion stream will be produced by the same method as the one in the ion source, using a heated cathode filament.(ref. 1)

e.) SPECIFICATIONS

Since a thruster comparable to those which will be used on the Phoenix probe has never been built, it is difficult to say how one would perform. most of these results were obtained from tables, or from crude approximations from similar data calculated by the Jet Propulsion Laboratory. The information has been combined from several sources, and in some instances represents the state of the art system which may not be attainable.

(ref. 2)

AVERAGE THRUST.....	0.5 NEWTONS
SYSTEM THRUST.....	2.0 NEWTONS
SPECIFIC IMPULSE.....	5000 SECONDS

BEAM DIAMETER.....	30 CM
THRUSTER LIFETIME.....	125,000 HOURS
POWER REQUIRED/THRUSTER.....	20 KW(E)
NUMBER OF THRUSTERS.....	6
NUMBER OF OPERATIONAL THRUSTERS.....	4
MASS/THRUSTER.....	106 KG
DRY SYSTEM MASS.....	636 KG
PROPELLANT MASS.....	12000 KG
WET SYSTEM MASS.....	12636 KG

3.) ATTITUDE AND ARTICULATION THRUSTERS

The thrusters which will be used for controlling the attitude and articulation of the spacecraft, like the primary thrusters, will be ion rockets. They will be very similar to the primary thrusters conceptually, but will be on a smaller scale. In order to control the attitude of the spacecraft, six thrust vectors will be needed. For each direction two thrusters will be present. This makes a total of 12 AA thrusters, 6 operational, and 6 for redundancy.

(ref. 3)

AVERAGE THRUST.....	0.005 NEWTONS
SPECIFIC IMPULSE.....	2650 SECONDS

BEAM DIAMETER.....	8 CM
THRUSTER LIFETIME.....	>15000 HOURS
POWER REQUIRED/THRUSTER.....	0.2 KW(E)
NUMBER OF THRUSTERS.....	12
MASS/THRUSTER.....	28 KG
SYSTEM MASS.....	340 KG

4.) POWER SOURCE

It is clear from the specifications for the ion rocket that a great deal of electrical power will be required. Specifically, to run the four thrusters will require 80 kwe. In addition, power must be reserved for other subsystems onboard Phoenix. Development of such a power source has been pursued intensely in recent years. The main product of this research and development is the sp-100 nuclear reactor. The sp-100 has an electrical power output of 100 kw. This will fulfill the 80 kw required by the four operational thrusters, and leave 20 kw for other subsystems. The other subsystems should not require nearly that much power. The reactor lifetime is about 7 years at maximum power output, and longer for output less than maximum. Since the sp-100 onboard the phoenix spacecraft will be operating at about 82%, it will be assumed that the reactor lifetime is 10 years. Since the mission is expected to take about 15 years, it will be necessary to bring two reactors. Another benefit of using NEP is that it allows the other subsystems as much as 100 kw for several years after arrival at the destination. Thus science projects requiring large amounts of power can be conducted over long periods of time.

(ref. 4)

THERMAL POWER OUTPUT.....	1.4 MW(T)
ELECTRICAL POWER OUTPUT.....	100 KW(E)
REACTOR LIFE AT MAXIMUM OUTPUT.....	7 YEARS
REACTOR LIFE AT 82 %.....	10 YEARS
REACTOR MASS.....	640 KG
SHIELD MASS.....	860 KG
HEAT TRANSPORT MASS.....	445 KG
REACTOR I & C MASS.....	210 KG
POWER CONVERSION MASS.....	315 KG
HEAT REJECTION MASS.....	835 KG
POWER CC&D MASS.....	370 KG
STRUCTURE MASS.....	265 KG
SYSTEM MASS.....	4600 KG

5.) INTERACTIONS WITH OTHER SUBSYSTEMS

In addition to the thermal and plume interactions which are associated with chemical propulsion spacecraft, there are also reactor neutron and gamma fluxes as well as electromagnetic fields associated with an electric propulsion spacecraft. Thermal interactions are minimized by the fact that the spacecraft subsystems are integrated along a thermal gradient. The high temperature reactor at one end, intermediate temperature equipment in the middle, and low temperature science instrumentation at the other end. Other interactions, as well as thermal, are reduced by putting distance between the interactive

elements.(ref. 2) Since I do not really have an understanding of most of these interactions, details on the configurations required by two interactive elements was obtained from examples done by the Jet Propulsion Laboratory.

D.) PROBLEMS

Many problems have come up during the design of Phoenix and its propulsion system. One problem is the political pressure of having a nuclear reactor onboard a space vehicle. It will be difficult to convince the public that the reactor will remain safe in the event of an accident at launch even though it has been verified to remain safe in almost any type of disaster. Another problem has been demonstrating the true effectiveness of NEP. Almost everything in the design of a space mission is geared to the optimal level of Chemically propelled rockets. When NEP performs at this level, it appears to be an inferior method of propulsion. Thus, in order to sell the Phoenix program it may be necessary to turn it up a notch in mission objectives as to utilize the full potential of NEP. I have encountered many problems in the design of the Phoenix propulsion system. Some of these problems are that details related to this type of propulsion are difficult to find if they even exist, and often data conflicts depending on the source. Another design problem is that optimizing computation dealing with many aspects of the design are difficult, or at least exceed my level of education. Thus, I am often required to go on blind faith as to the validity of some of the results.

REFERENCES

- 1.) Jahn, Robert G., "Physics of Electric Propulsion", Mc Graw-Hill, 1968
- 2.) Garrison, Philip W., "Nuclear Electric Propulsion Spacecraft Configuration Study", AIAA, April 1983
- 3.) Poeschel, Robert L., "A Comparison of Electric Propulsion Technologies for Orbit Transfer", AAIA, April 1983
- 4.) Mondt, J. F., "Development Status of the SP-100 Power System", IAA paper 89-2591, July 1989
- 5.) Oats, Gordon C., "Aerothermodynamics of Gas Turbine and Rocket Propulsion", AIAA, 1984]

SUMMARY OF ABBREVIATIONS

C ³	COMMAND, CONTROL, AND COMMUNICATION
AI	ARTIFICIAL INTELLIGENCE
CDS	COMMAND DATA SYSTEM
R.F.P.	REQUEST FOR PROPOSAL
D.O.D.	DEPARTMENT OF DEFENSE
RH32	RADIATION HARDENED 32-BIT PROCESSOR
GVSC	GENERAL PURPOSE VERY HIGH SPEED INTEGRATED CIRCUIT SPACEBORNE COMPUTER
HGA	HIGH-GAIN ANTENNA
LGA	LOW-GAIN ANTENNA
HPBW	HALF-POWER BEAMWIDTH
RTI	REAL-TIME INTERRUPT
DSN	DEEP SPACE NETWORK
N.E.P.	NUCLEAR-ELECTRIC PROPULSION

Command, Control, and Communications

Group 7

The document "Request for Proposal for an Unmanned probe to Pluto" lists requirements which must be understood and complied with if this preliminary design work is to be useful in the ongoing design process which will result in the eventual construction of an unmanned probe to be sent to the celestial body known as Pluto. While all requirements listed in the R.F.P. (Request for Proposal) pertain to the development of the C³ (Command, Control, and Communication) subsystem, only those requirements which most directly apply to the C³ subsystem are explicitly discussed in this portion of this document. A table listing requirements that are of particular importance is shown below (table C³1).

TABLE C³1 : REAL AND IMPLIED REQUIREMENTS

- Select microprocessors and peripherals for Phoenix
- Select software to optimize spacecraft autonomy
- Select and size communications hardware for mission that allows transmission at adequate speed with high quality
- Develop overall communications plan, including ground communications
- Recognize and defend against pointing problems and communications loss
- Optimize mass, size, strength, reliability, cost, and performance
- Components must be space qualified
- Provide sufficient computer speed and storage to implement Artificial Intelligence
- Provide sufficient data storage for scientific objectives
- Utilize components available no later than 1999
- Design hardware to be redundant when possible
- Design software to be as robust and autonomous as possible
- Transmit and receive command, telemetry, tracking and science data

To comply with the requirements in the R.F.P. a modified design-by-design approach was followed. Reference materials pertaining to the C³ subsystem were found without excluding references that did not specifically pertain to the exact R.F.P. requirements. These references were used to gain a general knowledge of the C³ subsystem on past and proposed space missions. The general knowledge from these sources was then used to interpret the design requirements that were imposed by the R.F.P. and by the evolving designs of the other Phoenix subsystems. This synthesis of general knowledge, R.F.P. requirements, evolving Phoenix probe design, and information attained from AAE 241 class notes shaped further research and design work as it applied to the C³ subsystem. After an initial design was reached, the subsystems were consciously integrated and an iterative process was begun to optimize the overall performance of the Phoenix .

A major responsibility of the C³ subsystem design team is to select computer equipment to be used on the Phoenix. Driving factors in the selection of the computer equipment for the Phoenix probe were dominated by the desire for greater autonomy than previously attempted in spacecraft design. This desire for autonomy, specifically through the implementation of AI (Artificial Intelligence), requires that the computer system for the Phoenix must be faster and have more memory than past NASA interplanetary probes. Therefore, it is important that the fastest microprocessors available be selected and combined with a large amount of internal memory and external storage. Three microprocessors were seriously considered for use in the development of the Phoenix computer system. They include the D.O.D. (Department of Defense) developed RH32 (Radiation Hardened 32-bit Processor), the Department of Energy's Sandia

Application 3300, and the D.O.D. developed GVSC (General Purpose Very High Speed Integrated Circuit Spaceborne Computer). The RH32 was selected due to the high speed of its 32 bit architecture and the added reliability its radiation hardening will afford in the environment of our Nuclear-Electric Propulsion system and the environment of Venus or Jupiter in the event of a gravity assist fly-by. The entire computer system will be loosely based on the multiply redundant CDS (Command and Data subsystem) used on the recent Galileo space probe. Six RH32 microprocessors in combination with eight memory units have been selected to be linked by a bus running at approximately 400 KHz with a RTI (Real Time Interrupt) running at approximately 15 Hz (a configuration similar to what was used as a part of Galileo). The internal memory can be backed up to and loaded from an external storage system utilizing the space proven magnetic tape that NASA has used on numerous past interplanetary missions.

This computer hardware will be used to implement an artificially intelligent autonomous system that has been referred to as an "intelligent associate".¹ The capabilities of an AI system, which are expected to be available by the time of the Phoenix mission, will make the mission more productive and versatile than it could be without the use of AI technology. With an approximate round trip light time to Plutonian space in the neighborhood of eleven hours, the Phoenix must be able to carry out its mission without constant supervision from earth. The time that it takes for a signal to be sent to the Phoenix, demonstrates the correctness of the R.F.P. requirement that the spacecraft design should maximize autonomy and use AI wherever possible. Advantages gained by the implementation of autonomous systems in spacecraft design include a reduction of mission operation costs, an increase in overall mission productivity, and an increase in mission success

probability. Continuing work in the field of AI will provide many possible capabilities with which the Phoenix could be equipped. Capabilities which will be useful and practical for implementation in the Phoenix Probes CDS include distributed control of multiple subsystems, fault prediction and analysis, automated real time planning and replanning, and a reasoning/learning supervision of on-board systems. Using sets of "heuristic algorithms" and priorities the Phoenix Probes on-board computer systems will independently react to the changing environments that the craft will encounter. Through an integration of science data, engineering data, tracking, telemetry, and its programming, the Phoenix probe will respond to threatening situations and unique opportunities for scientific observation. The reprogrammable nature of current spacecraft computer components will also allow mission designers at earth a great deal of flexibility after the Phoenix has been launched. The R.F.P. states that the design of the spacecraft should not preclude its use for other missions, and the ability to reprogram the Phoenix computers is an important way in which this requirement is met. Much as the Voyager mission planners were able to send "patches" to deal with Voyager performance anomalies, so will the Phoenix and Phoenix mission planners be able to respond to changing mission circumstances and requirements. The inclusion of eight memory units (more than twice the memory of Galileo) allows much more flexible control of on-board systems during different phases of the mission. When the program for a certain mission operation is no longer needed it can be backed up to magnetic tape or discarded altogether leaving room for new programs to be implemented in system memory. In the event that multiple hardware failures should occur, defeating redundant design considerations, the situation could be handled through the use of programming "patches" which could account for the new spacecraft

performance characteristics. The extreme length of the light time from the Phoenix to earth during most of this mission also suggests the use of a "store and forward" command system.² In a "store and forward" system large blocks of commands are sent as a single communication to be received and verified before the execution of commands is begun, as seen in fig. C³1.

FIG C³1 : STORE AND FORWARD COMMUNICATION SYSTEM

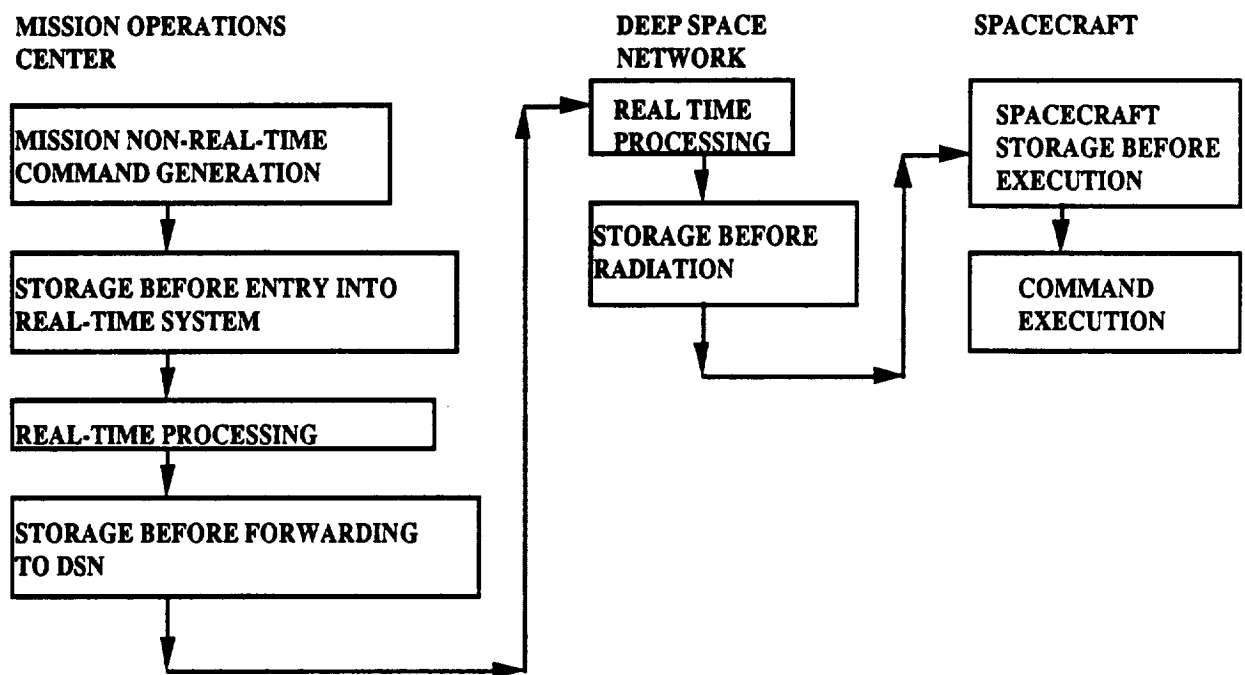

It should be noted that the use of an autonomous system and the "store and forward" technique need not preclude the use of near-real-time commanding of the Phoenix probe. A large amount of memory also allows redundancy in the gathering of scientific data for transmission to the earth. Copies of images or science data can be saved in memory or backed up to magnetic tape until confirmation of the reception of the data can be beamed back from earth, preventing the loss of important data taken during "one chance" scientific observations. It may also be

noted that the choice of N.E.P. and an orbiter mission will greatly reduce the number of these "one chance" observations. It is necessary that the C³ subsystem interact closely with all other on-board systems. The programs implemented as part of the CDS must be able to coordinate the activities of the power and propulsion subsystem; the attitude, articulation, and control subsystem; the thermal control system, and the science instrumentation subsystem. It is the responsibility of the on-board computer to transmit its commands and commands from earth to each of the other spacecraft subsystems.

It is also the responsibility of the C³ design team to select and or design the components that will be used to communicate between the spacecraft and the earth. To accomplish this different communication systems were considered, including laser and traditional multi-frequency radio communication. Though technology for laser communications is developing quickly, the desire to use off-the-shelf components when possible suggested that the use of S and X-band communications with the earth would be most cost effective. Often in Spacecraft communication system design antenna gain and power required for communications must be painstakingly evaluated to find the ideal balance between communications performance and spacecraft mass. On the Phoenix probe the abundant power provided by the XP-100 reactor and the overall large mass of the spacecraft imposed new parameters to be evaluated in the choice of spacecraft antenna. The most important factor driving the size of the Phoenix probe antenna is the transmission data rate that will be required to beam the science data gathered by Phoenix back to earth. Antenna's from past NASA missions were examined to see if they might meet the communication needs of the Phoenix spacecraft as they interacted with its larger power system. Pointing difficulties for different portions of the mission suggested that multiple antennas might be

included for use during different phases of the trip to Plutonian space. Interaction with the structures subsystem dictated that launch volume of the main HGA (high-gain antenna) could be minimized by using a folding system similar to that used on the Galileo mission. A comparison of different antenna types with respect to gain and pointing factors (HPBW, Half-power beamwidth) was made.

This information can be seen in table C³2. 3.

TABLE C³2 : Antenna Type Comparison

<u>Configuration</u>	<u>Gain above isotropic radiator</u>	<u>HPBW, deg</u>
Isotropic radiator	1.0	360.0
Infinitesimal dipole or loop	1.5	89.9
Half-wave dipole	1.64	78.0
Paraboloid	6.3 to 8.8 (Area/wavelength*2)	60 to 70(wavelength// diameter)

The Galileo main parabolic HGA was chosen to be used as a part of the Phoenix with some minor redesign. It was estimated to be large enough to meet the data rate transmission requirements of the Phoenix probes science subsystem while still remaining small and light enough to be launched with the rest of the craft. The redesign would involve the use of lighter structural materials and antenna shielding, as the Phoenix HGA will not be used as a solar shield as it was on the Galileo mission. The Phoenix variant of the Galileo main antenna will fold to be stowed at launch as did its predecessor. The Phoenix HGA will communicate with the earth and DSN (Deep Space Network) using both X and S-band frequencies. The maximum power transmitted will be approximately 1 KW. This unprecedented amount of power is a result of the unusual

nature of our nuclear power source. The deployed diameter of the antenna will be approximately 4.8 meters, so that a minimum amount of redesign will be required on the Galileo antenna while still fulfilling all the antenna requirements for the Phoenix probe. In addition to the parabolic HGA a smaller LGA (low-gain antenna) will be used as part of the Phoenix design. The 1 meter LGA will be a half-wave dipole antenna. The modest increase in antenna gain over an isotropic radiator is made up by the 78 degree pattern through which communication with earth can be maintained using the LGA. The ease with which the Phoenix probe could reattain contact with the earth in the event of some problem makes this secondary antenna an important tool for increasing the mission success probability. The LGA will also play an important role in the early phases of the mission when propulsion concerns may be more crucial than the pointing of instruments and the HGA. The large HPBW of the Phoenix LGA will allow the spacecraft to almost constantly transmit and receive engineering, tracking, telemetry, and command transmissions should they be necessary. Fig.C³² shows a representation of the Phoenix Communication subsystem. 4.

FIG C³² : PHOENIX COMMUNICATION SYSTEM

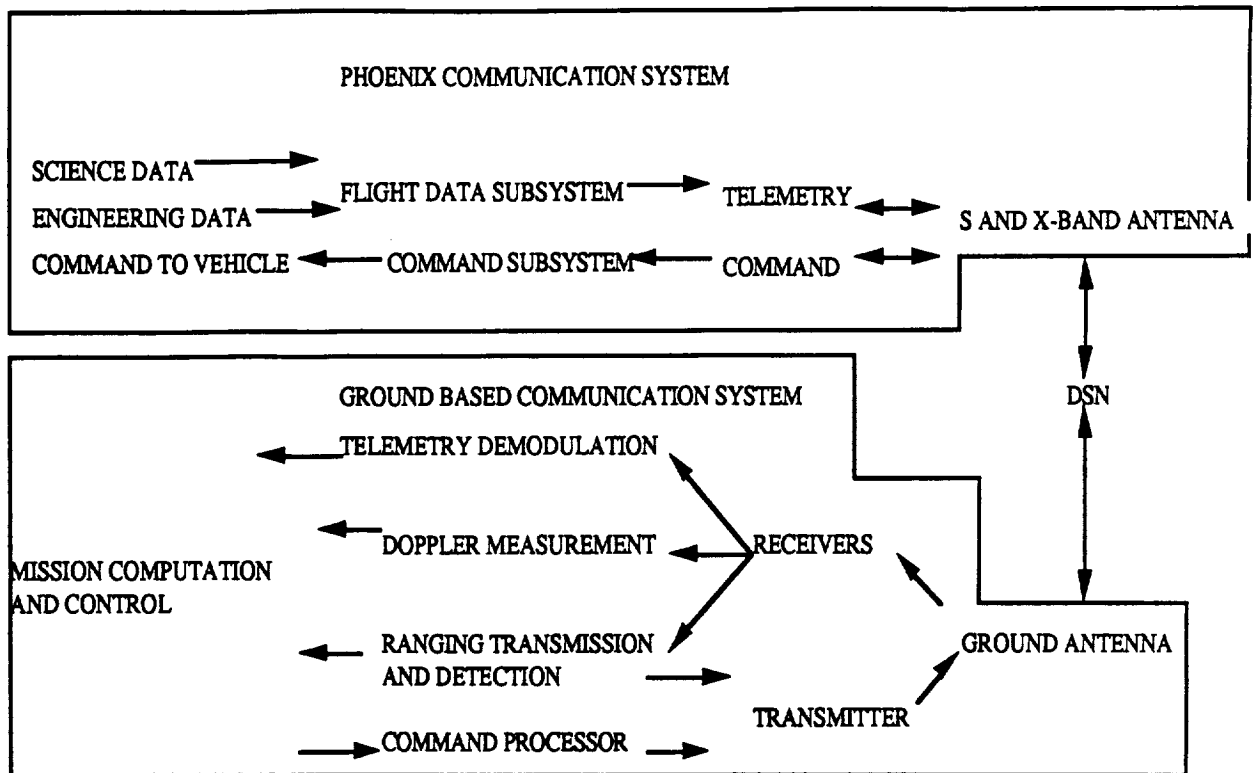

A unique and important consideration in the design of the Phoenix probe's communication system was the presence of the SP-100 nuclear reactor and mercury ion thrusters as part of the main propulsion unit. Though research into the effects of ion thrusters on a communication system of this type show that impact is slight (approximately a .2 K increase in antenna noise temperature)⁵, the general configuration of the Phoenix probe allows the communication system to be isolated from both the thrusters and the reactor by the main structural boom.

The design of the C³ subsystem involved making many compromises between the performance of a given piece of equipment and other factors imposed by the R.F.P. and the interactions between the C³ subsystem and others. The speed and storage capability of the computer system was maximized to allow for as complete as possible implementation of AI. The decisions regarding command procedures were driven by a need to make the Phoenix probe as autonomous as possible. Communication

system choices were mainly dictated by the vast distances and amount of science data that Phoenix will beam to earth from its position orbiting Pluto. Major design problems that have been identified include the uncertainty about the conditions of Plutonian space, the interaction between the N.E.P. system and communications, the relatively long life required for this mission, and the great distance between the earth and Pluto.

The following page shows a graphic depicting the Phoenix HGA.

The next page shows a breakdown of the major component masses of the C³ subsystem.

PHOENIX HGA

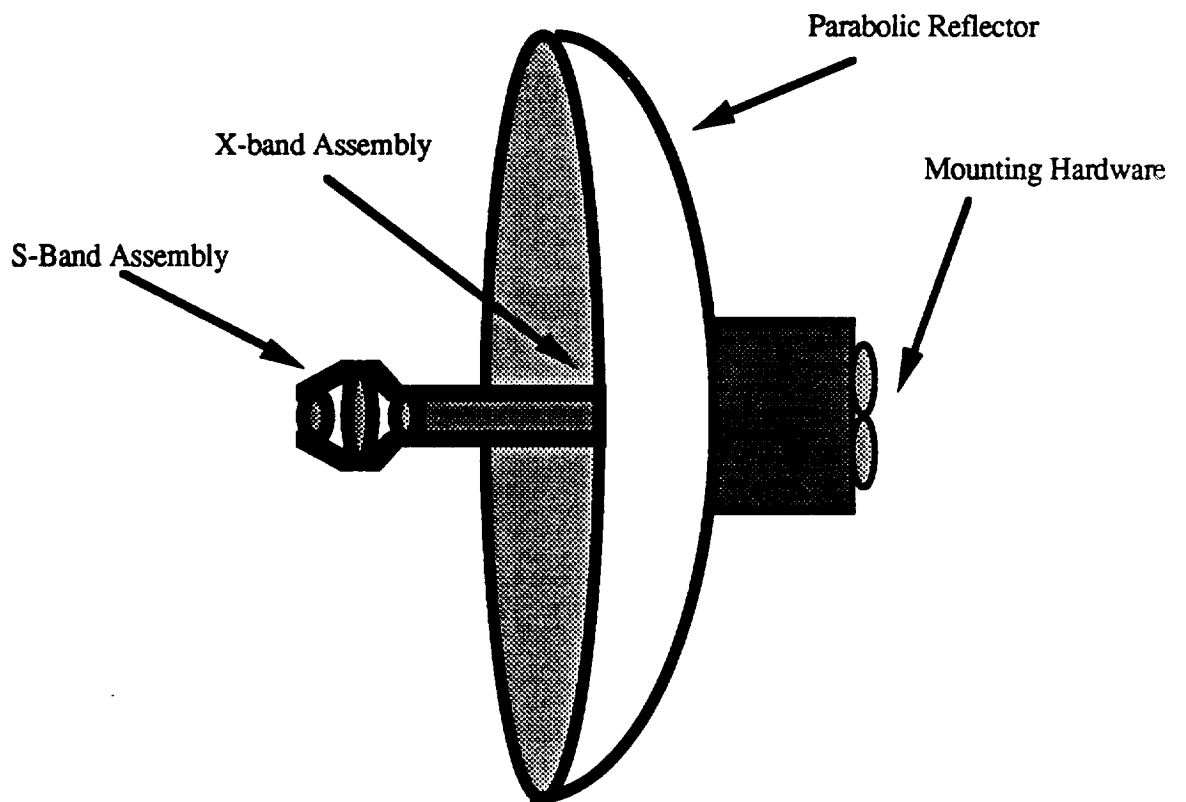
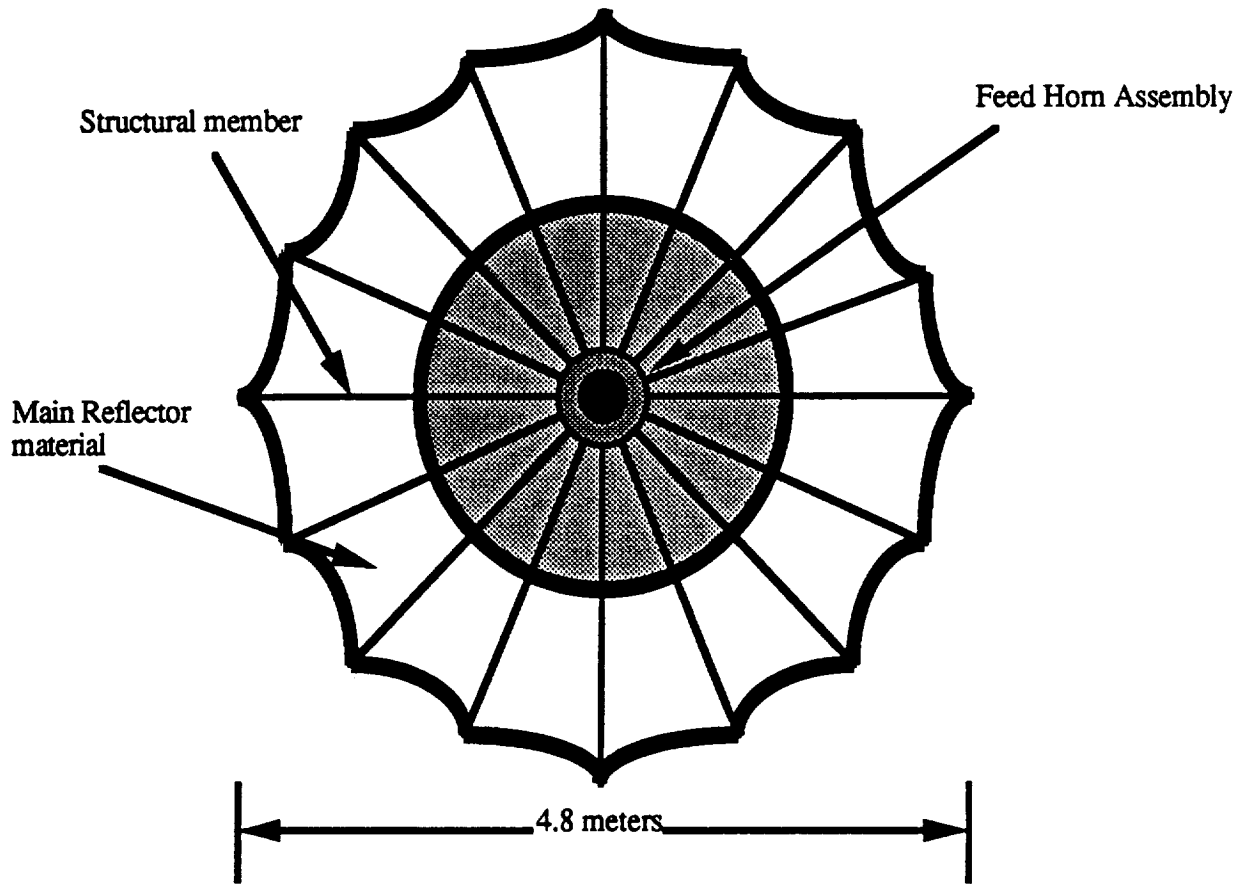

**COMMAND, CONTROL, AND COMMUNICATION
MASS ESTIMATES**

S/X BAND ANTENNA ASSEMBLY	5 KG
ANTENNA CABLING	4 KG
DATA STORAGE	19 KG
COMMAND DATA SUBSYSTEM	35 KG
MODULATION/DEMODULATION	10 KG
RADIO FREQUENCY SUBSYSTEM	50 KG
MAIN HGA	250 KG
HALF-WAVE DIPOLE LGA	50 KG

TOTAL MASS

APPROX. 423 KG

COMMAND, CONTROL, AND COMMUNICATION

References Cited

1. Technology for Future NASA Missions: Civil Space Technology
AIAA/NASA Conference
2. Deep Space Telecommunications Systems Engineering 1983
Joseph H. Yuen
3. Deep Space Telecommunications Systems Engineering 1983
Joseph H. Yuen
4. Deep Space Telecommunications Systems Engineering 1983
Joseph H. Yuen
5. Spacecraft Ion Beam Noise Effects
G.L. Anenberg

APPENDIX A: EQUATIONS

POWER RECEIVED

$$P_R = P_T + L_T + G_T + L_S + G_R + L_R \quad \text{IN DECIBELS}$$

PARABOLIC ANTENNA GAIN

$$G = 10 \text{ LOG}_{10} (.55 (3.14 \text{ DIAMETER/WAVELENGTH})^2)$$

SHANNON'S LAW

$$B = W \text{ LOG}_2 (P_R/P_N + 1) = \text{INFORMATION CAPACITY}$$

