

730

PRESENTATION 3.2.5

N91 - 17043

**ADVANCE ELECTRICAL POWER, DISTRIBUTION
AND CONTROL**

PRECEDING PAGE BLANK NOT FILMED

**ADVANCED ELECTRICAL POWER,
DISTRIBUTION AND CONTROL
FOR THE
SPACE TRANSPORTATION SYSTEM**

WHITE PAPER

**IRVING G. HANSEN
HENRY W. BRANDHORST, JR.
5400/POWER TECHNOLOGY DIVISION
NASA LEWIS RESEARCH CENTER
CLEVELAND, OHIO 44135**

NOVEMBER, 1989

BACKGROUND

MAJOR OBJECTIVES

SIGNIFICANT RESEARCH ACTIVITIES

KEY RESEARCHERS AND FACILITIES

The key people involved in various activities supporting the electrical actuation and power system work and the major facilities are listed in the quad charts.

TECHNOLOGY ISSUES AND MAJOR ACCOMPLISHMENTS

The quad charts list the key issues and major accomplishments to date that will impact the Space Transportation System.

CONCLUSIONS

SPACE TRANSPORTATION AVIONICS TECHNOLOGY SYMPOSIUM FLIGHT ELEMENTS ADVANCED ELECTRICAL POWER, DISTRIBUTION AND CONTROL

NOVEMBER 1989

TECHNOLOGY ISSUES:

- END-TO-END EPS MANAGEMENT WITH FAULT LIMITING, RECOVERY AND FAIL SAFE/FAIL OPERATIONAL RECONFIGURATION
- DISTRIBUTED vs. DEDICATED PMAD FOR REDUNDANCY, RELIABILITY, OPERABILITY
- BITE INTEGRATED INTO DESIGN AT MANUFACTURE
- ASA: DOT&E FOR ELECTRICAL ACTUATORS RETROFIT BY ORBITER STRUCTURAL INSPECTION DATE

MAJOR ACCOMPLISHMENTS:

- DEMONSTRATED MULT-REDUNDANT, FAULT TOLERANT, MICROPROCESSOR CONTROLLED SSF 20 kHz ELECTRICAL POWER DISTRIBUTION SYSTEM
- DEMONSTRATED VARIABLE SPEED DRIVES TO 200 HP, ELECTRICAL ACTUATORS TO 25 HP/DESIGNS TO 75 HP

CANDIDATE PROGRAMS:

- ADVANCED LAUNCH SYSTEM
- ASSURED SHUTTLE AVAILABILITY
- CIVIL AERO - POWER-BY-WIRE/FLY-BY-LIGHT
- LUNAR/MARS INITIATIVE
- AF/WRDC - MORE ELECTRIC AIRPLANE - RETROFIT F-16
- DAVID TAYLOR SHIP R&DC - ELECTRONIC NAVY

SIGNIFICANT MILESTONES:

- 1990 R&T BASE - COMPS, POWER SEMI'S
- 1991 1992 ADV. DEV. - SSF, ALS
- 1995 DOT&E
- ▽ LEV. 5 MATURITY △
- △ LUNAR/MARS NEED DATE
- △ NSTS NEED DATE
- VALIDATION NEAR COMPLETE:
- ADVANCED HIGH POWER PMAD CONCEPTS APPLICABLE TO CANDIDATE PROGRAMS
- ADVANCED MOTOR CONTROL ENABLING INDUCTION MOTOR EXPLOITATION FOR LUNAR/MARS VEHICLES

SPACE TRANSPORTATION AVIONICS TECHNOLOGY SYMPOSIUM FLIGHT ELEMENTS ADVANCED ELECTRICAL POWER, DISTRIBUTION AND CONTROL

NOVEMBER 1989

ADVANCED ELECTRICAL POWER, DISTRIBUTION AND CONTROL

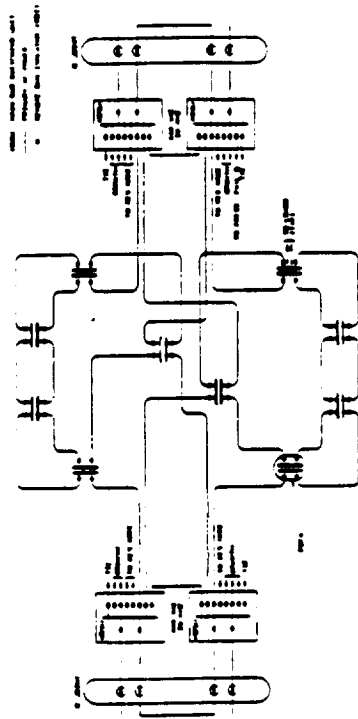

SPACE STATION RING DISTRIBUTION SYSTEM (EXTERNAL LOAD AREAS ONLY)

KEY CONTACTS:

- H. BRANDHORST/LeRC
- I. HANSEN/LeRC
- J. MILDICE/GDSS
- J. BIESS/TRW
- R. BECHTEL/MSFC

FACILITIES:

LeRC POWER TECHNOLOGY TESTBED

MAJOR OBJECTIVES:

- REDUCE COSTS TO LEO, LUNAR/MARS SURFACE
- REDUCE WEIGHT
- INCREASE AVAILABLE POWER/ENERGY
- IMPROVED REDUNDANCY MANAGEMENT
- IMPROVED POWER QUALITY, USER AVAILABILITY
- FAULT TOLERANT, INTEGRATED BITE

MAJOR MILESTONES (1990-1995):

SPACE STATION FREEDOM

1990 ADV. DEV. TEST BED DEMOS

ADVANCED LAUNCH SYSTEM

1990 ADV. DEV. DEMO OF IEPS

CIVIL AERO-FBL/PBW

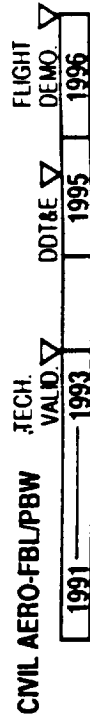

LUNAR/MARS INITIATIVE

1992 ADV. DEV. DEMO OF IEPS

STUDIES ADV. DEV. PROG.

TECHNICAL ISSUES

Electrical system reliability is in reality the probability of suitable electrical power being available to user loads. Long term reliability is achieved by parallel redundant elements in a single distribution block consisting of a source, storage (if required), and a distribution system all under active control and management. Uninterruptible, or secure power, for critical loads may be implemented by an additional block, or blocks, depending upon the requirements. Within a single block, fault limiting, fault isolation, and fault recovery through reconfiguration are implemented to maintain as much post fault capability as possible. This capability (fault tolerance) involves status sensing, intelligence, current limiting, and active switching. When all available technologies are fully reviewed, it becomes obvious that these requirements may be much more easily met by utilizing a distributed, alternating current (AC) system. The system physics, the system fault recoverability, and the overwhelming terrestrial experience support this conclusion. Given an AC system several engineering decisions remain as regards the distribution voltage, waveform, and frequencies. While each specific application must be evaluated, point designs and operating experience to date support the selection of ultrasonic, sinusoidal power systems operated at the highest voltage appropriate to the situation.

SIGNIFICANT RESEARCH ACTIVITIES

As the accompanying quad-charts show there are six candidate Government supported programs working on relevant technologies

with significant applications for electric actuators and integrated power distribution and control systems. The programs are listed below with a brief explanation and noteworthy technology.

ADVANCED LAUNCH SYSTEM

Four Advanced Development Tasks are directed to the development and demonstration of electrical actuators and electrical power systems for the proposed new family of heavy lift launch vehicles. Actuators for thrust vector control (TVC), fuel valves and others with ratings in the ranges of 5, 70, and 75 Hp are being developed with subsystem demonstrations scheduled before March 1992. Figure 2 shows the ALS EMA system demonstration activities and milestones. An additional task is being conducted by LeRC to provide advanced motor drive technology, motor designs, BITE concepts, and transfer the technologies directly to all the prime contractors. The 5 Hp drive has already been demonstrated, the 25 Hp drive and actuator will be tested in March 1990, and the 30 and 40 Hp actuators will be ready by early 1991.

The power semiconductors necessary to meet the peak horsepower ratings are now available and improved MOSFET Controlled Thyristors (MCT) will be available in six months. Circuit topologies and system architectures are available which meet required redundancy, fault tolerance and fault containment. An appropriate power control and distribution system integrated with an avionic and propulsion system will be demonstrated in 1992.

ASSURED SHUTTLE AVAILABILITY

A preliminary ASA study by Rockwell Downey concluded that electric actuation was feasible, the technology was ready, and a five to six year schedule was reasonable to accomplish the DDT&E required to retrofit electric actuators into the existing Shuttle Orbiters. JSC is also supporting an analysis of ten Shuttle subsystem processing costs and turn-around flows. The EMA system is planned as the vanguard item to trade against the existing hydraulic systems.

CIVIL TRANSPORT: POWER-BY-WIRE/FLY-BY-LIGHT

This program is a planned new initiative for FY91. The power-by-wire (PBW) portion of the program includes an all electric secondary electrical power system that includes electrical actuators, embedded engine generators, fixed bleed turbine engines, advanced power distribution architectures, BITE and electric driven environmental control systems. Studies at LeRC on a 767 class aircraft have shown a potential weight and fuel savings of nearly 10% by using the PBW approach. Plans in this initiative include development, fabrication, testing and flight evaluation of engineering prototypes by 1996.

LUNAR/MARS INITIATIVE

Preliminary assessments have been made by the agency for a report to the Space Council. Several scenarios, require relatively high power, long duration, automated, distribution systems. Surface rovers and mining vehicles will require reliable, power efficient actuation and variable speed motor drive systems.

AF/WRDC - MORE ELECTRIC AIRPLANE - RETROFIT OF F-16

Wright Research and Development Center under their More Electric

Airplane Program has contracted General Dynamics of Fort Worth, TX to do a trade study of the F-16 resulting in development costs, risks, and payoffs expected by replacing hydraulics with electrical actuation systems. Performance, operability, maintainability and recurring cost reductions are the main drivers. This work is jointly sponsored by NASA LeRC.

DAVID TAYLOR SHIP R&D CENTER - ELECTRONIC NAVY

The US Navy has begun a massive joint program with DARPA to develop technologies that will enable all electric variable speed drives of both the main propulsion engines and new weapon systems. This will require megawatts of power generation and distribution capability with new types of electronic control and motor drives. They plan to demonstrate a 200 Hp drive by the end of 1991 and work toward a capability to drive 3600 Hp induction motors. Motor drives and the required very high power MCTs and associated electronic components are already under intensive development and planned qualification. New programs include development of electric actuators to replace many hydraulic actuation systems.

BUILT-IN TEST EQUIPMENT (BITE)

The maximum advantage of BITE will be realized when the capability is introduced into the equipment at manufacture. The BITE may then be calibrated and compared during all following acceptance testing.

As presently conceived, BITE will support system checkout and verification for ALS, and eventually provide the system status information allowing automatic control of long duration power

requirements. When considering large multinode power distribution systems, the advantage of pushing intelligence deeply into the system cannot be minimized. With centralized intelligence software complexity, and its attendant verification problems, grows much more rapidly than the system does. However, as intelligence is pushed down, the problem approaches that of the verification of replicated simple instructions. Finally, it is intended to use BITE to provide the physical foundation, and experience base for the eventual incorporation of trend analysis, failure prediction, and expert systems in general.

BACKGROUND

For over a decade NASA LeRC has been evaluating, and defining power components and system characteristics as part of our OAST charter. This work provided a foundation for the Advanced Aircraft Secondary Power System Study in 1985 which concluded that a 20 kHz AC system had great advantages particularly when multikilowatt, multiply redundant, distribution was involved. This study also recognized the advantage of high frequency power for motor operation was proposed. In the intervening years, the technology has been reduced to practice and evaluate with several full power testbeds. The baseline 20 kHz power distribution for Space Station is shown in the diagram. The system comprised two independantly powered feeders (left and right) similar to conventional aircraft practice. All loads had current limiting remote power controllers (RPC's) and could draw power from either feeder subject to power management. Differential protection was provided between nodes to monitor

soft and hard faults. In this system the RPC's were programmable for: off, on, trip level, monitors indicated switch status, the current flowing, and produced a flag when over current trips occurred. Similar instrumentation, but no current limiting or tripping, was provided by the node switches or remote bus isolators (RBI's). This system was assembled at Lewis and operated with total success for over a year.

It is the confidence gained from the Space Station Testbeds, advanced components, and operating experinece that forms the foundation for advanced electrical power, distribution, and control. These advances in power control and newly demonstrated capabilities for control of a larger class of inherently rugged, induction motors using pulse-population-modulation with field-oriented control from a high frequency source makes this approach even more attractive. For example, selective steering of high frequency, small energy pulses and switching at zero crossing significantly reduces the size and weight of the electronics while practically eliminating EMI/EMC effects.

CONCLUSIONS

High frequency power distribution and management is a technology-ready state of development. As such, a system employs the fewest power conversion steps, and employs zero current switching for those steps. It results in the most efficiency, and lowest total parts system count when equivalent systems are compared. The operating voltage and frequency are application specific trade off parameters. However, a 20 kHz Hertz system is suitable for wide range systems.

