

54

p.9 / 309

A HYPERSONIC RESEARCH VEHICLE TO DEVELOP SCRAMJET ENGINES

THE OHIO STATE UNIVERSITY

N91-18167

Four student design teams produced conceptual designs for a research vehicle to develop the supersonic combustion ramjet (scramjet) engines necessary for efficient hypersonic flight. This research aircraft would provide flight test data for prototype scramjets that is not available in groundbased test facilities. The design specifications call for a research aircraft to be launched from a carrier aircraft at 40,000 ft and a Mach number of 0.8. The aircraft must accelerate to Mach 6 while climbing to a 100,000-ft altitude and then ignite the experimental scramjet engines for acceleration to Mach 10. The research vehicle must then be recovered for another flight. The students responded with four different designs, two piloted, waverider configurations, and two unmanned vehicles, one with a blended wing-body configuration, the other a delta wing shape. All aircraft made use of an engine database provided by the General Electric Aircraft Engine Group; both turbofanramjet and scramjet engine performance using liquid hydrogen fuel was presented. This paper describes the students' conceptual designs, and the aerodynamic and propulsion concepts that made their designs practical, as well as touching upon interesting problems that surfaced during the design process.

INTRODUCTION

The Ohio State University (OSU) Advanced Aeronautical Design Program (ADP) has focussed upon hypersonic vehicle design concepts for the last three years. With the assistance of staff from the NASA Lewis Research Center, OSU has developed conceptual hypersonic designs of both commercial, 250-passenger aircraft and 10-passenger executive jets. These craft, weighing near one million pounds and 200,000 pounds, respectively, could cross the Pacific in less than three hours. This year, the design project continues the hypersonic tradition with the task of designing a Hypersonic Research Vehicle (HRV) that would be used to develop and flight test the specialized air-breathing, supersonic combustion ramjet engine called a scramjet.

The earlier OSU design concepts operated at Mach numbers below Mach 6, a flight regime that allows variable-cycle air-breathing engines that can use subsonic combustion processes. However, as flight Mach numbers increase above Mach 6, scramjet engines become the only viable air-breathing concept as shown in Fig. 1, a graph of specific impulse versus flight

Mach number for several candidate engines. Conceptual designs at these high Mach numbers must, therefore, employ scramjets. The National Aerospace Plane (NASP), for example, now scheduled for first flight in the later part of this decade uses scramjets to accelerate to near orbital speeds.

Although the concept of scramjet engines has been studied for many years, the practical application of the supersonic combustion process has not been tested extensively. One reason is the lack of adequate ground simulation facilities that can duplicate the high temperatures and pressures the engine will encounter during hypersonic flight. Figure 2 illustrates the ascent and descent trajectories of a single stage to orbit (SSTO) air breather and superimposes the groundbased facilities presently available to these scramjet propulsion concepts. The newest facility, the Rocketdyne Hypersonic Flow Laboratory (RHYFL) appears to cover a reasonable range of flight conditions, but its duration of operation is in the millisecond range, making engine testing difficult. Before risking new aircraft designs on a relatively undeveloped engine concept, it

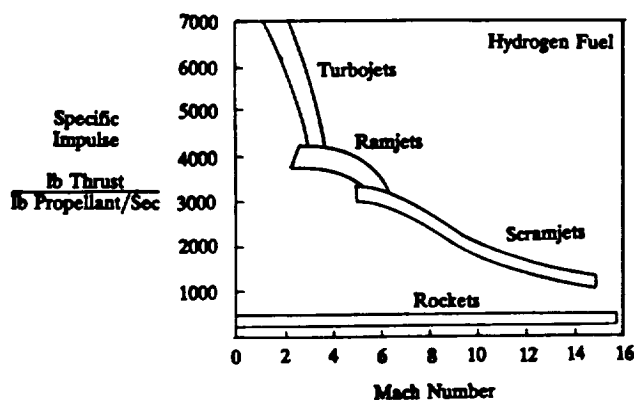

Fig. 1. Propulsion System Operating Regimes

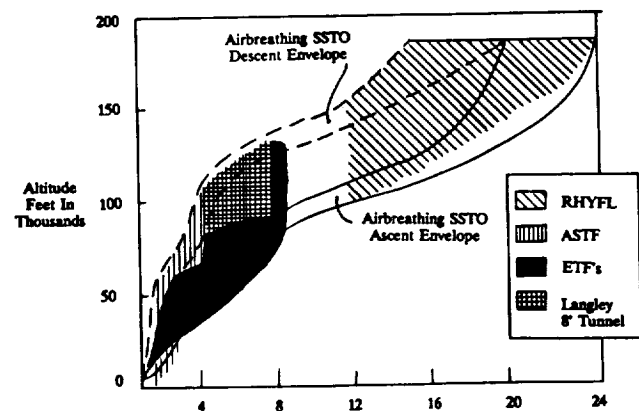

Fig. 2. Ground Test Facility Capability

ORIGINAL PAGE IS
OF POOR QUALITY

appears prudent to develop a test vehicle that can expose the scramjet to the actual flight environment.

The OSU design specification (Table 1) evolved from this desire to provide just such a flying platform to test the scramjet engines. In an effort to reduce costs and fuel weight, the HRV is to be carried to altitude by another aircraft, dropped at Mach 0.8, and then accelerate and climb to Mach 10 at 100,000 ft. The HRV must maintain steady, level flight for two minutes to allow engine performance data to be recorded and then return to base. The vehicle may be either piloted or unmanned, but the intent was for an aircraft that would be well instrumented and used for many engine development flights. The means to accelerate from Mach 0.8 to Mach 6 was not specified.

Table 1. HRV Specifications

<ul style="list-style-type: none"> • Air lifted and dropped from carrier aircraft at Mach 0.8 and 40,000 ft • Accelerate and climb to Mach 6 and 100,000 ft • Ignite scramjet engine(s) and accelerate to Mach 10 • Maintain Mach 10 at 100,000 ft for two minutes • Return and land at base

Four design teams were formed to develop the HRV to these specifications. Two teams chose to design manned vehicles, two selected unmanned concepts. All design groups had engine data packages from the General Electric Aircraft Engine Group. The packages provided engine net thrust, air flow, and fuel flow rates for two types of engines, a turbofanramjet and a scramjet. Full-scale turbofanramjets, shown in Fig. 3, can produce 20,000 lb of thrust at Mach 0.8 and 40,000 ft, and can operate to Mach 6 at 100,000 ft. The scramjet module, also shown in Fig. 3, produces 5,000 lb of thrust at Mach 10 and 100,000 ft. GE also provided the scaling laws to allow the design groups to tailor the engines for their particular configuration.

The four design concepts are presented in the following section. The teams were designated Red, White, Blue, and Gold with the Red and White groups working on the manned aircraft and the Blue and Gold teams developing unmanned vehicles.

The aircraft that would drop the HRV was not considered by the OSU student teams. In a unique international cooperative effort, students from Ecole Polytechnique Feminine designed the carrier aircraft.

AIRCRAFT DESIGNS

The Red group aircraft, Figure 4a, is a waverider configuration to take advantage of the high lift-to-drag ratios that can be obtained using this shape. It is a manned aircraft; therefore, it must carry life support systems. The Red team's configuration is the largest aircraft having a planform area of 2,300 sq ft and a drop weight of 59,000 lb. It uses two turbofanramjets, scaled at 65%, outboard of four scramjet modules. Since the turbofanramjets are outboard, they are not completely contained in the waverider shape. This separation of engines allows the inlets for each propulsion system to be optimized for its own operating range.

The White group's aircraft is also a waverider and is shown in Fig. 4b. It has a drop weight of 53,000 lb and a planform area of 2,100 sq ft. Five scramjet modules are located on the bottom surface of the body under the two, 80%-scaled turbofanramjets, providing an over-under engine configuration. A single inlet for both engine systems is possible with this arrangement and the turbofanramjets can be completely contained in the waverider body. This aircraft is the second manned configuration.

The major design thrust of the Blue group was to design a small aircraft to make the carrier's job easier. This was accomplished using the blended wing-body configuration shown in Fig. 4c and a rocket assist. Drop weight is 44,000 lb and planform area is 1,711 sq ft. A feature of this aircraft is its separate inlets for the three scramjet modules and the 92% turbofanramjet. The turbofanramjet engine is located on the bottom surface of the body; conversely, scramjets are on the top surface of the body. For each system the inlet and the respective forebody are integrated to give the best system performance. This configuration is the first of the unmanned aircraft.

The Gold team designed a delta configuration (Fig. 4d). It uses one, 100% turbofanramjet and four scramjet modules to power the vehicle. As with the Blue team they use a rocket assist for the initial acceleration from the drop. This was done to minimize fuel usage and to increase acceleration in going to the test conditions. Higher accelerations can be used because it is the second unmanned configuration. The drop weight of 62,000 lb includes the weight of the solid rocket boosters; the planform area is 720 sq ft.

General Electric Turbofanramjet

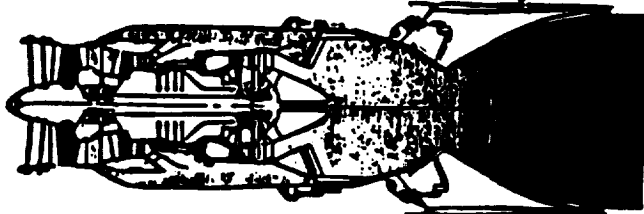

General Electric Scramjet Module

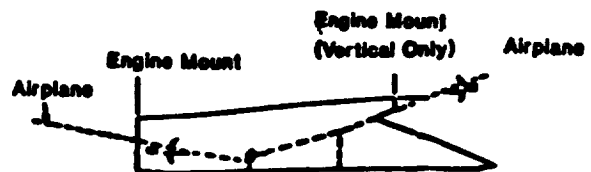
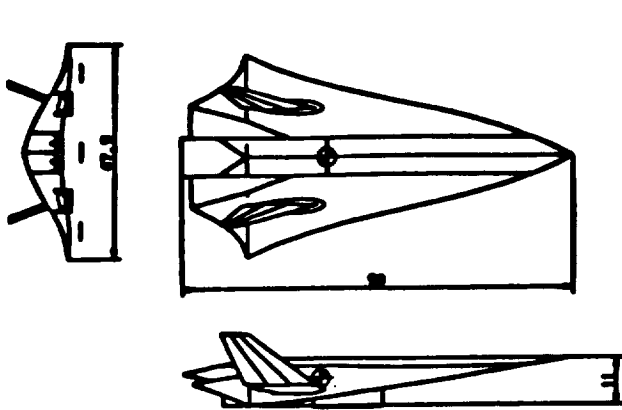

Fig. 3. Propulsion Systems



Red Team

**Specifications
Manned**

**Planform Area: 2300 sq. ft.
Wing Loading: 20.85 pcf. (Landing)
Drop Weight: 89,000 lbs.
Dry Weight: 47,500 lbs.**

Propulsion

**Turbofanramjets: 2 @ 85%
Scramjets: 4**

Figure 4a

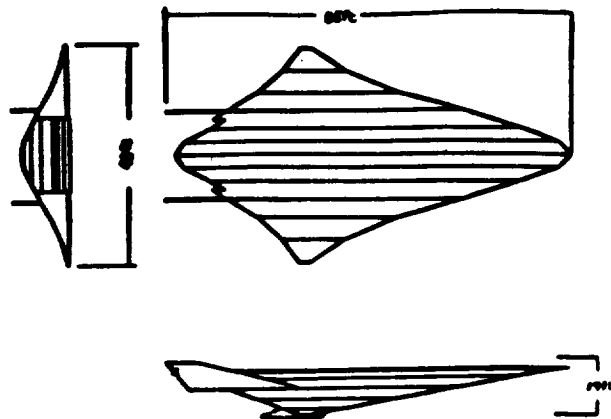

White Team

**Specifications
Manned**

**Planform Area: 2100 sq. ft.
Wing Loading: 19.6 pcf. (Landing)
Drop Weight: 83,000 lbs.
Dry Weight: 39,172 lbs.**

Propulsion

**Turbofanramjets: 2 @ 80%
Scramjets: 6**

Figure 4b

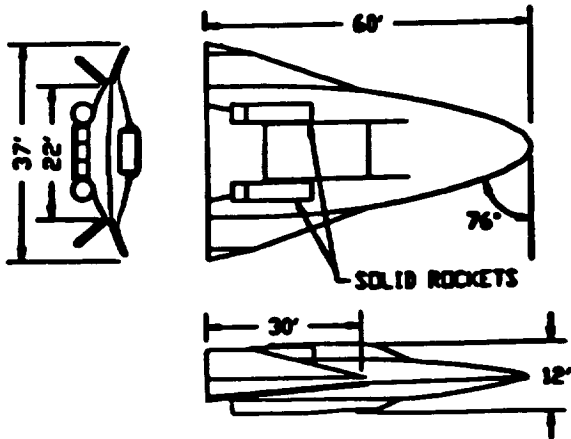

Blue Team

**Specifications
Unmanned**

**Planform Area: 1711 sq. ft.
Wing Loading: 37.44 pcf. (Landing)
Drop Weight: 44,000 lbs.
Dry Weight: 30,400 lbs.**

Propulsion

**Turbofanramjets: 1 @ 92%
Scramjets: 8**

Figure 4c

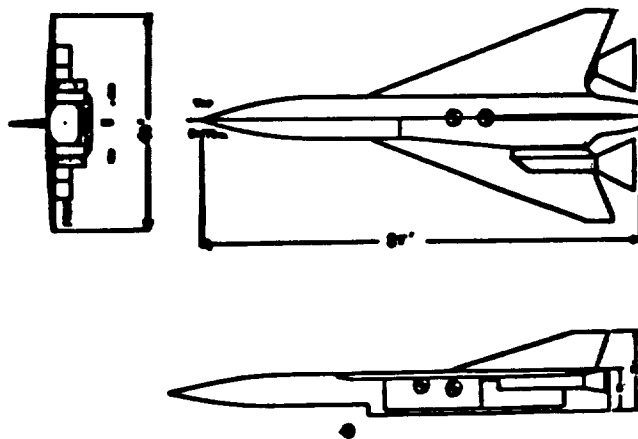

Gold Team

**Specifications
Unmanned**

**Planform Area: 720 sq. ft.
Wing Loading: 81.08 pcf. (Landing)
Drop Weight: 62,000 lbs.
Dry Weight: 36,774 lbs.**

Propulsion

**Turbofanramjets: 1 @ 100%
Scramjets: 4**

Figure 4d

Fig. 4. Aircraft Configurations

DESIGN RESULTS

Each design group did a comprehensive study of their configuration weight, aerodynamics, propulsion system (including inlet configuration), and heating. There is not space to review all the details of each design here; instead representative results from the teams' designs will be discussed to provide a flavor of the HRV design process.

Weight Estimate

Several weight estimating methods were used by the design groups. Methods in Nicolai⁽¹⁾ and Roskam⁽²⁾ texts and a NASA Lewis Research Center WAATS program⁽³⁾ provided empty and gross weight estimates. The HRV's drop weights ranged from 44,000 lb to 62,000 lb. The unmanned vehicles had the lowest empty weights, 30,400 lb and 36,800 lb for the Blue and Gold teams respectively, while the manned vehicle empty weights were 47,500 lb and 39,200 lb for the Red and White designs.

Figure 5a illustrates the component weight distribution for the White and Blue team designs. The heavier White manned aircraft had a structure and engine weight of 28% and 32% of the total drop weight of 53,000 lb. The unmanned Blue HRV had a structural and engine weight of 13% and 22% for its drop weight of 44,000 lb. The distribution of the fuel used for the three phases of powered flight: acceleration under turbofanramjet to Mach 6, acceleration of Mach 10 during scramjet operation, and the fuel used during the two-minute, steady flight, is also shown in Fig. 5b. While the waverider uses

47% of its fuel during turbofanramjet acceleration, the unmanned Blue HRV uses but 31% since the Blue vehicle uses a short rocket boost. On the other hand, the Blue HRV burns 720 lb in two minutes at Mach 10, whereas the White, low-drag waverider, uses but 600 lb.

Engines

One of the first considerations when deciding on the propulsion system was the type of fuel to be used. Figure 6a shows a comparison of mass energy density and volumetric energy density for three fuels liquid hydrogen (LH₂), liquid methane (LCH₄), and Jet A. Although LH₂ has a high mass density, a penalty is paid because of its low volumetric density. The Candidate Engine Performance presented earlier indicates good performance for all the engine systems using hydrogen fuel; therefore, all groups decided to use the LH₂ and take the volumetric penalty. The Candidate Engine Performance Chart also shows the performance of solid rockets in the range of the proposed mission. Early in their design studies, the teams found that if their aircraft were to use solid rockets exclusively for the acceleration, the fuel weight would be prohibitively high because of the low specific impulse of rockets. None of the four configurations used solid rockets as the only acceleration system.

Because of the volume penalty when using liquid hydrogen, the design groups used several methods for reducing the fuel weight. A large portion of the fuel is used during the scramjet burn during the acceleration from M=6 to M=10. The White team did a trade study to determine the optimum number of scramjet engines to minimize the fuel while limiting the weight penalty of additional scramjet modules. Figure 6b shows the number of engines versus the fuel weight to accelerate the HRV. As modules are added the required fuel weight is reduced. The students determined that the optimum number of scramjets is five because the weight penalty paid for having the sixth scramjet module is greater than the fuel savings.

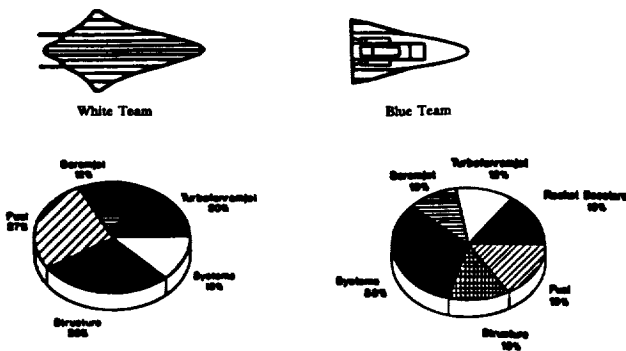

Fig. 5a. Weight Percentage Distribution

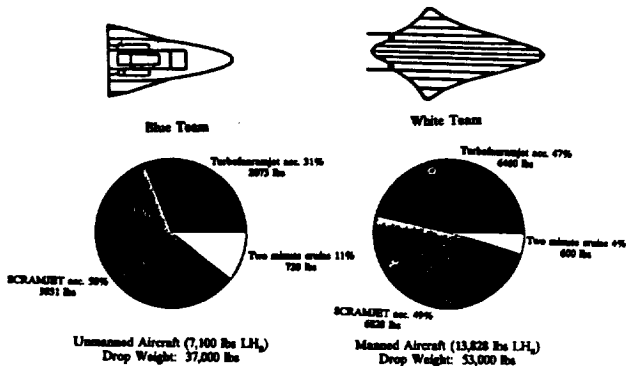

Fig. 5b. Fuel Weight Percentage Distribution

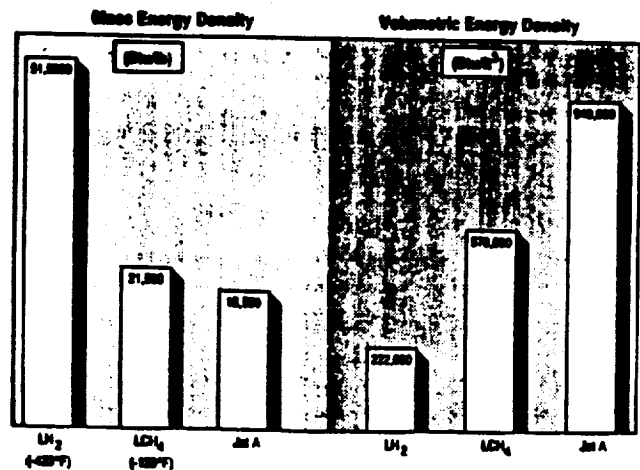

Fig. 6a. Fuel Comparison

ORIGINAL PAGE IS OF POOR QUALITY

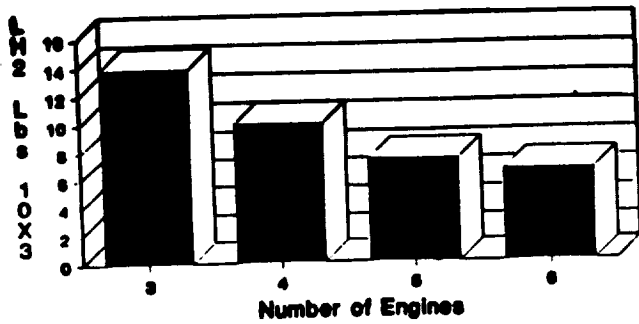

Fig. 6b. Number of Engines vs. Fuel Weight for Scramjet Operation

Typical performance data obtained from the engine data for the two types of engines are presented in Fig. 7. The thrust as a function of Mach number for the turbofanramjets is shown as a function of altitude. The engine thrust increases with Mach number, but decreases significantly with altitude. The scramjet engine Mach number performance is shown as a function of Q, the dynamic pressure, a convenience, since many climb trajectories are performed at constant Q. Again, the decrease in net thrust with altitude (lower Q at fixed Mach number) is observed.

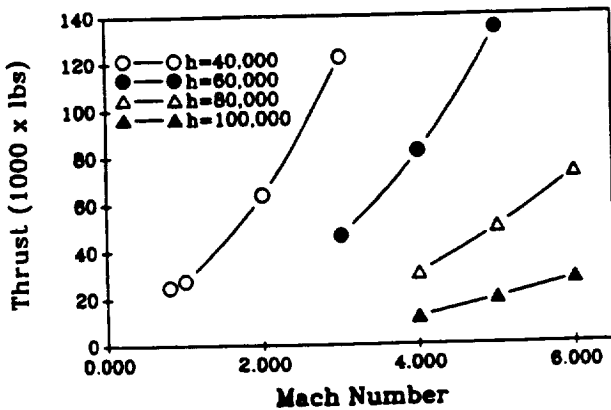

Fig. 7a. Turbofanramjet Performance

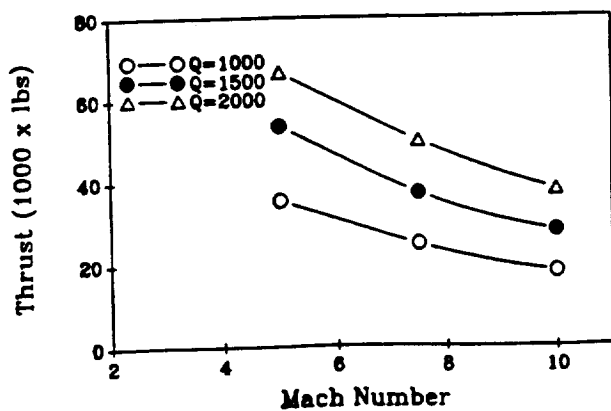

Fig. 7b. Scramjet Performance

An integral part of the propulsion installation is the inlet design. Each group had different inlet designs; inlet configurations varied from completely separate engine systems, as in the Blue design, to common inlets for both engine types, as in the White design. The inlet designs shown in Fig. 8 are representative of the inlet configurations examined by the student teams. All are variable geometry inlets, necessary to accommodate the changing capture areas required for the large range of Mach numbers and altitudes. An example of the pressure recovery for two inlets is shown, one for the turbofanramjet and another for the scramjet inlet. The figure is for the Red aircraft which had separate inlets for both engines; the turbofanramjet inlet is axisymmetric, while the scramjet inlets are two-dimensional.

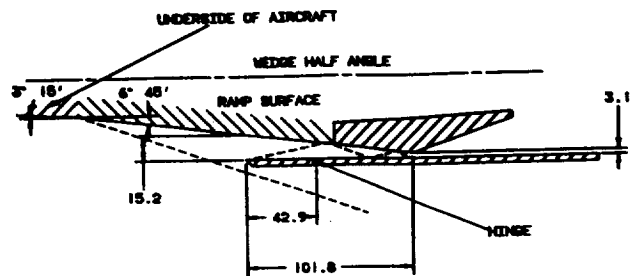

Fig. 8a. Scramjet Inlet M = 6.0

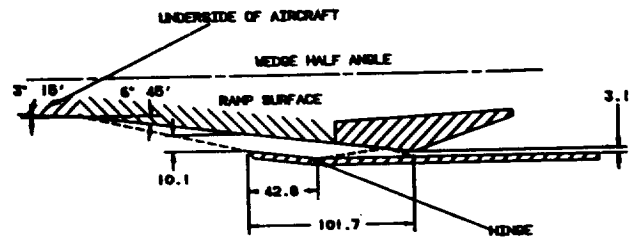

Fig. 8b. Scramjet Inlet M = 10.0

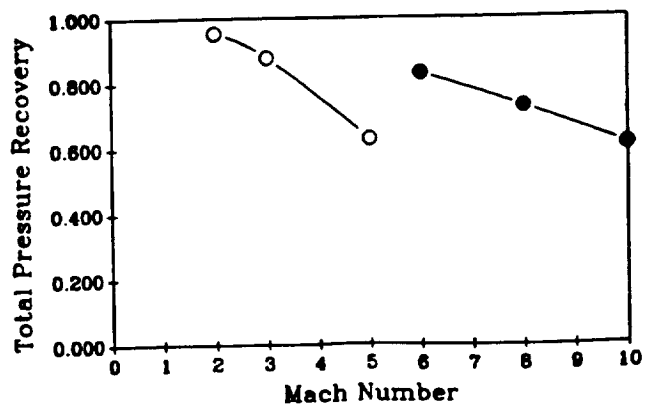

Fig. 8c. Inlet Pressure Recovery

Aerodynamics

A vital part of the design is the vehicle aerodynamics. Because each aircraft flies through subsonic, supersonic, and hypersonic regimes, several methods were used to determine the aerodynamic characteristics. Primarily, the methods outlined in Nicolai's book, *Fundamentals of Aircraft Design*⁽¹⁾ were used to determine the subsonic and supersonic characteristics. Other methods incorporated included shock expansion theory and Newtonian methods for hypersonic flows.

The two manned aircraft that used a waverider configuration developed the shape using a program called MAXWARP developed by Dr. S. Corda and Dr. J. Anderson at the University of Maryland⁽⁴⁾. Since a waverider is optimized for a certain Mach number and altitude, initially there was a question of the validity of using a waverider shape for these aircraft since they will not be at any particular Mach number for an extended period of time. Figure 9 shows a comparison of waverider shapes at Mach numbers of 6, 8, and 10. After comparing these shapes and consulting with the University of Maryland, it was determined that the off-design characteristics of the waveriders will be good enough to justify their use in the designs. Using the methods discussed above, plots of the Red group's waverider drag polar and lift-to-drag ratios versus Mach number were generated and are shown in Fig. 10. Note the

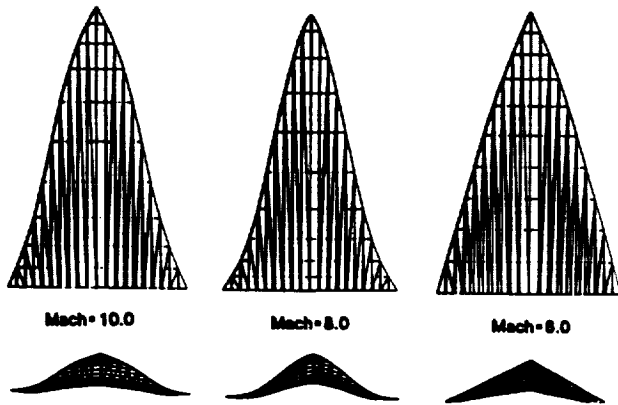

Fig. 9. Waverider Comparison

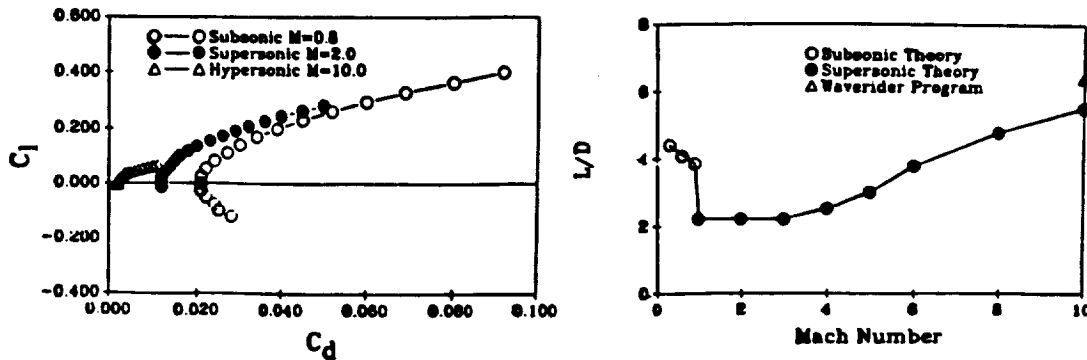

Fig. 10. Theoretical Aerodynamics

thrust "pinch" as the vehicle accelerates through Mach 1 and the increasing lift-to-drag ratio as the waverider reaches its design flight condition.

A model test of the Red group's waverider was conducted in the OSU 3' x 5' subsonic wind tunnel using a 1/72 scale model. Lift and drag coefficients were found as a function of angle of attack using a three-component balance. These data, shown in Fig. 11, agree well with the subsonic aerodynamic estimates.

Heating and Cooling

In any hypersonic design, aerodynamic heating is an important concern. Since the HRV is to fly at hypersonic speeds for less than 15 minutes, questions were raised about the time required to reach equilibrium skin temperature. After discussing this problem with engineers at NASA Lewis Research Center, the OSU mentor center, it was determined that the vehicles could heat to steady state in less than a second and there would be no need to account for unsteady heat transfer. The worst case of steady-state heating was considered by each group; that is, the highest skin temperature was reached when the convective heat input was balanced by radiative output. This equilibrium temperature distribution for the Red team's aircraft is shown in Fig. 12.

Because of these high temperatures, over 3500°F at the nose and inlets, special materials and several methods for cooling are required. Wherever possible radiative cooling of the structure is used because it requires no coolant to be carried. Hastelloy-x is used in these areas. Other systems incorporated are liquid convective cooling and a carbon/carbon integrated heat pipe structure for the leading edges, shown in Fig. 12. At the nose, a JTA graphite composite must be used. While this material can sustain high temperatures, it must be replaced after a few flights.

Flight Profile

One of the interesting operational aspects of this project was examining the flight profile of a typical research flight. By optimizing the climb trajectory, a substantial saving in fuel can be obtained. Figure 13 shows one of these optimized

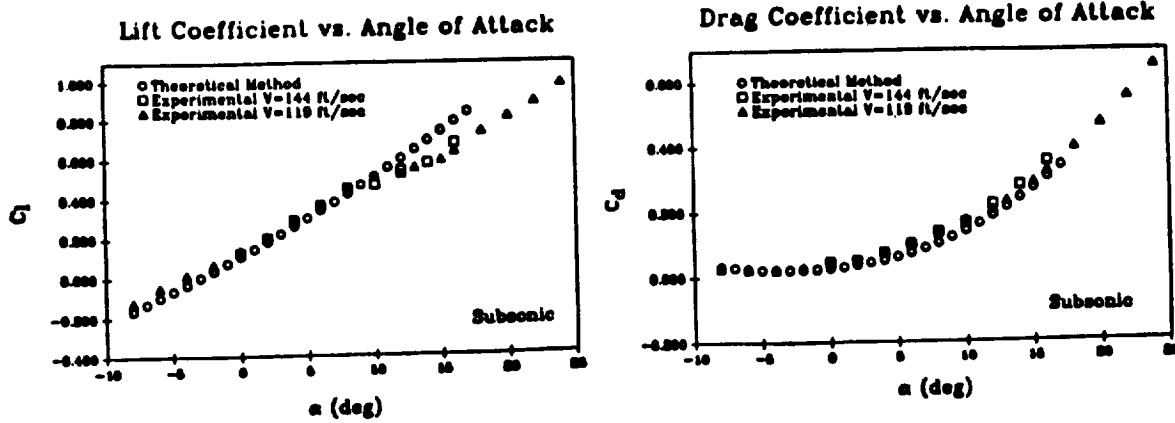

Fig. 11. Wind Tunnel Data

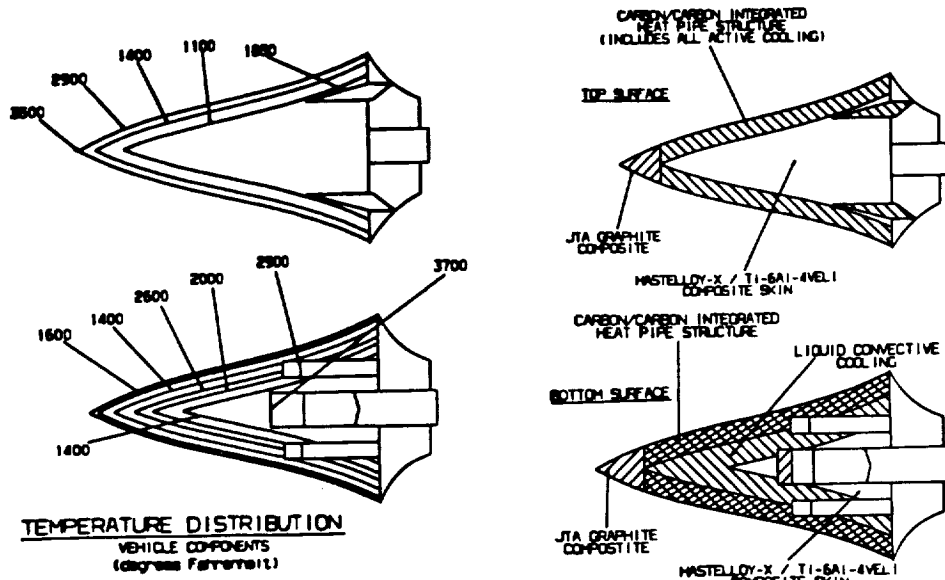

Fig. 12. Equilibrium Temperature Distribution and Materials

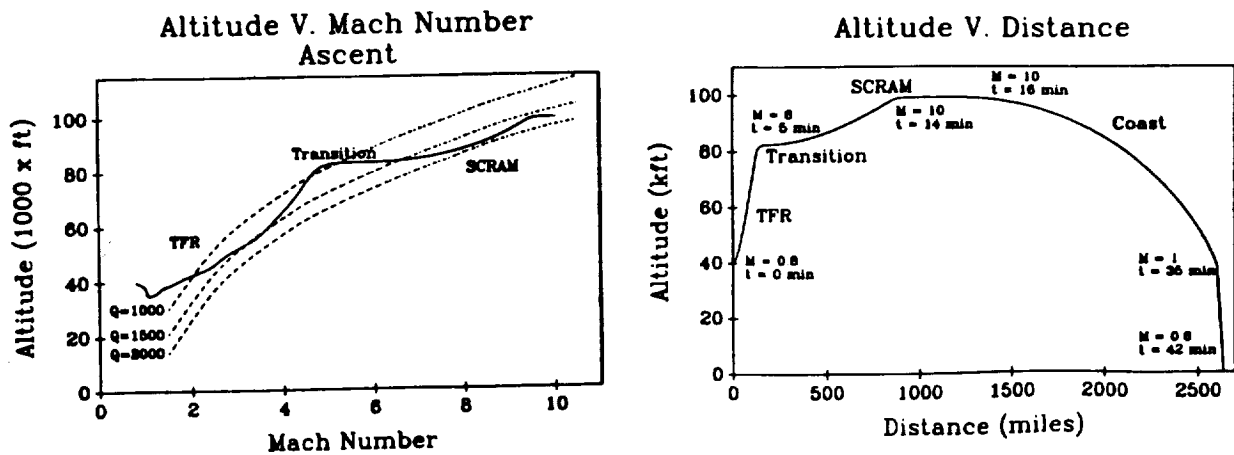

Fig. 13. Flight Profile

trajectories. Also shown is the transition from turbofanramjet to scramjet operation. A somewhat unexpected result is the distance required for a research flight. Accelerating to Mach 10 and maintaining Mach 10 for two minutes requires a straight line distance in excess of 1500 miles.

The large distance to accelerate and slow down creates a problem of where to fly the research vehicle. Two prospective flight paths are depicted in Fig. 14. One path is a drop just off the coast of Alaska with a landing at NASA Dryden Flight Testing Center; the other is a drop in Maine and a landing at NASA Kennedy Space Center in Florida. At this time the west coast site would probably be used, because all four of the research vehicle designs have skids for landing gear and the Dryden site is the dry lake bed rather than concrete. The drop location also impacts the carrier aircraft design, requiring the carrier aircraft to fly out a considerable distance with the HRV.

A final observation is that the flight paths are all over water. This is done so that any sonic booms created by the aircraft do not disturb populated areas. An estimate of the largest overpressure caused by a sonic boom is shown in Fig. 14. Of interest is the overpressure of one lb/ft² which may be a tolerable sonic boom pressure over land.

SUMMARY

Four conceptual designs for a hypersonic research vehicle have been developed by four design teams. Two concepts are manned vehicles, two are pilotless. The motivation behind these designs was to allow supersonic combustion ramjets to be tested and refined in the actual flight environment, since ground based facilities cannot duplicate the extreme pressures and temperatures of hypersonic flight. Characteristics of the four configurations are presented in Fig. 15.

The summary table (Fig. 15) presents a comparison of pertinent performance data for the four HRVs. For example, the low wing loading of the waveriders in contrast to the unmanned vehicles can be noted on the order of 20 lb/ft



Type	Manned	Manned	Unmanned	Unmanned
Gross Weight	59,000 lbs	53,000 lbs	44,000 lbs*	62,000 lbs*
Empty Weight	47,500 lbs	39,172 lbs	37,000 lbs**	47,000 lbs**
Length	90 ft	85 ft	30,400 lbs	36,774 lbs**
Span	48 ft	48 ft	60 ft	85 ft
W/S (Landing)	20.8 pcf	18.8 pcf	37 ft	40 ft
T/W (Drop)	0.42	0.57	37.4 pcf	51.0 pcf
L/D (M=10)	6.5	6.2	1.59 *	1.2 *
Cost (Billions)	\$4.79	\$4.46	0.36 **	0.44 **

*with booster rockets
**without booster rockets

Fig. 15. Aircraft Summary

compared with double that value for the unmanned aircraft. The low wing loading, of course, will allow low landing speeds for the waveriders. Similarly, the thrust-to-weight ratios for the waveriders are significantly lower than the rocket-boasted, unmanned HRVs, requiring longer acceleration times and increased hydrogen fuel usage. On the other hand, the efficient lift-to-drag ratios near L/D = 6 of the waveriders can be compared with the lower L/D values of the more conventionally configured aircraft.

Cost of producing a single research aircraft is also shown in Fig. 15, with the manned aircraft approximately a billion dollars more expensive than the unmanned HRVs. Whether this cost can be borne by the United States over the next five or six years to develop an operational scramjet engine with the potential for efficient air breathing flight to near orbital speed was not a consideration for the students. The students did consider the merits of a manned machine versus an unpiloted vehicle with each group supporting its design view. Manned

**ΔP vs Altitude
Boom Pressure**

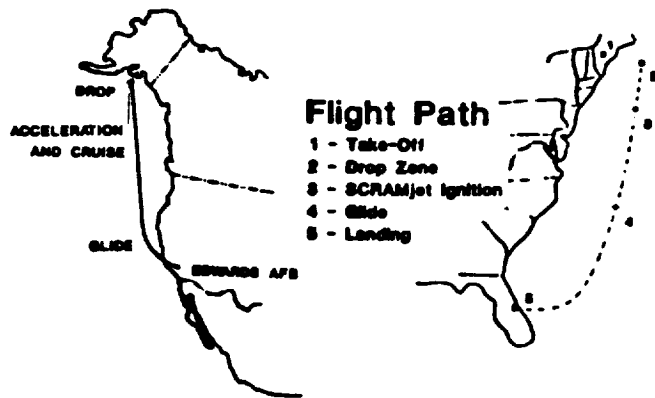
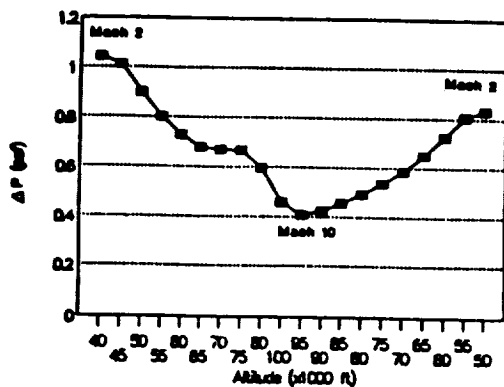

Fig. 14. Sonic Boom Overpressure and Flight Path

vehicles would be flexible with pilots handling unexpected engine problems and research opportunities at the expense of weight and life support systems, while unmanned vehicles would not endanger a pilot's life, be cheaper and lighter in weight. Yet, a successful manned HRV would provide much operational hypersonic flight experience, once the engines were proven. While these questions remain, the design task was certainly well worth the student effort, with the results a contribution to this controversial problem.

REFERENCES

1. Nicolai, L.M., *Fundamentals of Aircraft Design*. San Jose, CA: METS, Inc., 1974.
2. Roskam, J., *Airplane Design*. University of Kansas, 1986.
3. Glatt, C.F., *Weights Analysis of Advanced Transportation Systems*. NASA CR-2420.
4. Corda, S., "Viscous Optimized Hypersonic Waveriders Designed from Flows over Cones and Minimum Drag Bodies". University of Maryland, 1988.

