

3-10
N-10
N91-18314

JTB 1-1-80

Steady-State Phase Error for a Phase-Locked Loop Subjected to Periodic Doppler Inputs

C.-C. Chen and M. Z. Win
Communications Systems Research Section

The performance of a carrier phase-locked loop (PLL) driven by a periodic Doppler input is investigated. By expanding the Doppler input into a Fourier series and applying the linearized PLL approximations, it is easy to show that, for periodic frequency disturbances, the resulting steady-state phase error is also periodic. Compared to the method of expanding frequency excursion into a power series, the Fourier expansion method can be used to predict the maximum phase-error excursion for a periodic Doppler input. For systems with a large Doppler-rate fluctuation, such as an optical transponder aboard an Earth-orbiting spacecraft, the method can be applied to test whether a lower order tracking loop can provide satisfactory tracking and thereby save the effort of a higher order loop design.

I. Introduction

Coherent carrier phase recovery using a phase-locked loop (PLL) has become an integral part of digital communication systems [1-3]. By performing coherent demodulation using the recovered signal carrier, the receiver can achieve 3 dB of performance gain over systems using non-coherent demodulation techniques. The ability to recover and track the incoming carrier phase can also lead to a significant performance gain in related applications such as coherent ranging and spacecraft navigation [4].

The performance of a phase-locked receiver depends critically on the ability to accurately recover the carrier

phase. Synchronization errors between the incoming signal and the local reference can quickly lead to a degraded signal-to-noise ratio (SNR) and a large power penalty. The design of the loop, therefore, must ensure proper phase tracking under the operating conditions. In general, the performance of the PLL is influenced by the additive circuit noise, the oscillator frequency noise, and the frequency characteristics of the signal it is designed to track. The effect of channel noises on the performance of the PLL has been studied extensively [1-4]. It is shown that, in general, the residual phase tracking error due to the additive noise increases with PLL bandwidth, whereas the tracking error due to the oscillator frequency noise decreases with increasing loop bandwidth. With a given SNR, therefore,

there is an optimal choice of receiver bandwidth and PLL design that minimizes the root-mean-square (rms) phase tracking error.

In addition to the channel and oscillator noises, the performance of the PLL is also affected by the frequency characteristics of the source. A simple first-order loop can provide adequate tracking only when the free-running frequency of the voltage-controlled oscillator (VCO) is equal to the frequency of the incoming signal. A second-order loop is needed to track a constant frequency offset, whereas a third-order loop is needed to track a signal with linearly varying frequency. In general, higher order loops are needed to compensate for higher order frequency disturbances. However, higher order loops present extra design complications since control loops higher than second order are not unconditionally stable. Furthermore, for systems with large dynamic frequency fluctuations, the frequency perturbations with orders higher than the control loop cannot be completely compensated by the loop. As a result, some residual phase tracking error always remains.

Since the performance of the PLL-based receiver depends on the ability to accurately track the carrier phase, it is important to estimate the amount of residual tracking error due to the higher order frequency perturbations. The analysis of PLL performance given a time-dependent Doppler input is generally accomplished by expanding the Doppler signal into a power series and then analyzing the effects of different power terms separately. The power-series expansion provides a simple and intuitive method of expanding the Doppler frequency term. However, it is difficult to justify dropping the higher order terms since the steady-state phase error due to higher order terms does not converge.

For a very special class of system, the Doppler signal is periodic. In this case, the phase-locked loop equation can be examined by performing a Fourier decomposition rather than a power-series expansion. In this article, the procedure of analyzing the residual phase tracking error using a Fourier expansion of the frequency perturbation is outlined.

II. Carrier Phase Tracking Loop

The essentials of a carrier PLL include a phase detector, a loop filter, and a VCO. Shown in Fig. 1 is a typical implementation of a radio-frequency (RF) PLL. The phase detector detects the phase difference between the incoming signal and the output of the VCO. For carrier phase tracking applications, an RF mixer is generally used as

the phase detector. The mixer output is filtered by the loop filter with transfer function $F(s)$. The sum frequency term at the mixer output is filtered by the loop filter such that the loop effectively responds only to the difference frequency term. When the frequency of the signal is equal to that of the VCO, the difference frequency term is simply proportional to $\sin \phi(t)$, where $\phi(t)$ is the phase difference between the signal and VCO output.

The filtered phase-difference signal is subsequently injected into the receiver VCO. The output frequency of the VCO is linearly dependent on the input voltage signal. When the loop eventually reaches a locked condition, the phase-error signal, $\phi(t)$, will be such that it is governed by the following loop equation:

$$\frac{d\phi(t)}{dt} + AKf(t) \otimes [n(t) + \sin \phi(t)] = \beta(t) + f_N(t) \quad (1)$$

where $n(t)$ is the additive noise, $f_N(t)$ is the oscillator frequency noise, and $\beta(t)$ is the frequency error between the signal and the local oscillator. The loop mechanization is represented by the signal amplitude, A ; the VCO gain constant, K ; and the impulse response of the loop filter, $f(t)$. For systems operating with an ample signal-to-noise ratio, the effect of additive noise is usually very small. At the same time, a relatively high SNR allows oscillator frequency noise to be tracked out. For this analysis, therefore, the focus is on the frequency detuning term.

If the phase error is small (the loop is in lock), the sine function can be approximated by its argument, and the phase error of the PLL can be adequately described using the following linearized form:

$$\frac{d\phi(t)}{dt} + AKf(t) \otimes \phi(t) = \beta(t) \quad (2)$$

The integral-differential equation in Eq. (2) can be simplified into a linear differential equation of the form

$$\frac{d^n \phi(t)}{dt^n} + \dots + a_1 \frac{d\phi(t)}{dt} + a_0 \phi(t) = b_{n-1} \frac{d^{n-1} \beta(t)}{dt^{n-1}} + \dots + b_1 \frac{d\beta(t)}{dt} + b_0 \beta(t) \quad (3)$$

where the coefficients $\{a_j\}$ and $\{b_j\}$ are related to the loop transfer function $H(s)$ by

$$\frac{b_{n-1}s^{n-1} + \dots + b_1s + b_0}{s^n + \dots + a_1s + a_0} = \frac{1}{s + AKF(s)}$$

$$= \frac{1}{s}[1 - H(s)] \quad (4)$$

Equivalently, it can also be simplified into a set of first-order differential equations [5]. Given the frequency detuning process, $\beta(t)$, Eq. (3) can be solved for the steady-state phase error. For a time-varying frequency detuning process, one method of simplifying the analysis is to expand $\beta(t)$ into a Taylor series and then retain only terms sufficient for the analysis. Since the system is linear, the solution obeys the superposition principle and is equal to the sum of solutions of individual expansion terms.

In general, the solution to Eq. (3) includes the transient response and the steady-state response terms. The transient response, which depends on the initial conditions, dies out after a time period that is on the order of the inverse loop bandwidth. If the phase error converges to a constant, the steady-state solution can be easily solved by Laplace transforming Eq. (3) and using the final value theorem, i.e.,

$$\lim_{t \rightarrow \infty} \phi(t) = \lim_{s \rightarrow 0} s \cdot \Phi(s) = \lim_{s \rightarrow 0} \frac{sB(s)}{s + AKF(s)} \quad (5)$$

where $F(s)$ and $B(s)$ are the Laplace transforms of $f(t)$ and $\beta(t)$, respectively. Equation (5) is applicable only when the steady-state solution exists as a constant value. For higher order perturbations, the final value in Eq. (4) does not converge, and the Laplace transform cannot be used to solve for the steady-state response. Fortunately, it is known from the linear differential equation theory that the general solution to Eq. (3) for a driving force of the form $\beta(t) = a_n t^n$ is a polynomial of order n . The steady-state phase error can therefore be solved by substituting the polynomial of order n into the right-hand side of Eq. (3) and then matching the coefficients.

Although the steady-state phase error can be solved by assuming a polynomial general solution, the resulting polynomial is diverging at $t \rightarrow \infty$. Since most physical systems do not have unbounded frequency variation, the higher order perturbation eventually dies down. The analysis of the PLL performance using higher order perturbation is therefore limited to the time period within which the perturbation is present. The loop design is said to be adequate if the effects of the higher order perturbation are small. Because of the complexity of designing higher order

tracking loops, the analysis of the time-varying Doppler term is generally limited to third order or less. Justifications for dropping the higher order terms, however, can be very difficult since the solution is not bounded.

III. Fourier Expansion of the Time-Dependent Doppler Signal

Since the frequency fluctuation at the input is generally bounded, polynomial approximation to the Doppler signal will eventually become greater than the input. If the time period of interest is longer than the time for the polynomial approximation to deviate from the signal, a better (higher order) approximation is needed to analyze the PLL behavior. For some class of missions such as Earth-orbiting satellites, however, the periodic orbit will result in a periodic Doppler input that should intuitively result in a periodic phase variation. For such a system, the steady-state solution can be more easily derived by expanding the Doppler signal into a Fourier series. The resulting linearized PLL equation can be written as

$$\frac{d\phi(t)}{dt} + AKf(t) \otimes \phi(t) = \beta(t) = \sum_{k=-\infty}^{\infty} c_k e^{ik\omega_0 t} \quad (6)$$

where ω_0 is the fundamental frequency (reciprocal of the period) of the perturbation. From linear differential equation theory, it is known that a linear differential equation responding to a sinusoidal driving term with frequency ω_0 will exhibit a general solution with an identical frequency. Again, the particular solution (transient response) is expected to die down with a time constant that corresponds to the eigenvalues of the characteristic equation. Furthermore, by using the superposition principle, solutions to different harmonics can be solved individually. Consequently, if the Doppler stimulus can be expanded into a Fourier series, the solution can be found using the superposition principle.

Two examples can now illustrate the power of this technique.

Example 1: First-Order Loop. It is well known from linearized PLL theory that the first-order loop can be used to track a constant frequency detuning (Doppler) with a constant phase offset. Higher order perturbation can result in a loss of lock. If such a loop is used to track a periodic frequency variation of frequency ω_0 , conventional analysis cannot adequately predict the resulting loop performance. However, by performing the spectral expansion of the Doppler signal

$$\beta(t) = c_0 \sin \omega_0 t \quad (7)$$

the general solution to the first-order loop can be written as

$$\phi(t) = \frac{a_0 c_0}{a_0^2 - \omega_0^2} \sin \omega_0 t + \frac{\omega_0 c_0}{a_0^2 - \omega_0^2} \cos \omega_0 t \quad (8)$$

where $a_0 = AK = 4B_L$ is related to the bandwidth of the loop. It is seen from Eq. (7) that a first-order loop can be used to track a periodic Doppler input, provided that the loop bandwidth, frequency variation, and Doppler period satisfy the condition for linearizing the loop equation, i.e., $\phi(t) \ll 1$ for all t . Furthermore, the resulting steady-state phase error is periodic with the same period as the driving term, but falls slightly out of phase from the driving input.

Example 2: Perfect Second-Order Loop. It is known from the linearized loop theory that a perfect second-order loop can be used to track out a constant Doppler rate with a steady-state phase error. The transfer function for the loop filter is

$$F(s) = \frac{1 + \tau_2 s}{\tau_1 s} \quad (9)$$

By substituting Eq. (9) into the PLL equation and converting the resulting equation back to the time domain,

$$\frac{d^2 \phi(t)}{dt^2} + a_1 \frac{d\phi(t)}{dt} + a_0 \phi(t) = \frac{d\beta(t)}{dt} \quad (10)$$

where $a_1 = AK\tau_2/\tau_1$, and $a_0 = AK/\tau_1$. The general solution to this equation can be reached by substituting the solution of the form

$$\phi(t) = P \sin \omega_0 t + Q \cos \omega_0 t \quad (11)$$

into Eq. (10) and equating the coefficients. It is found that the general (steady-state) solution due to the periodic Doppler input is given by

$$\begin{aligned} \phi(t) = & \frac{c_0 \omega_0^2 a_1}{(a_0 - \omega_0^2)^2 + a_1^2 \omega_0^2} \sin \omega_0 t \\ & + \frac{c_0 \omega_0 (a_0 - \omega_0^2)}{(a_0 - \omega_0^2)^2 + a_1^2 \omega_0^2} \cos \omega_0 t \end{aligned} \quad (12)$$

Again, the constants must satisfy the constraints that $\phi(t) \ll 1$. Note that the loop bandwidth can be related to the constants a_0 and a_1 by

$$B_L = \frac{a_0}{4a_1} + \frac{a_1}{4} \quad (13)$$

The difference between the Fourier solution and the power-series solution can be seen in Fig. 2 where the steady-state phase response of the linear loop to a sinusoidal frequency excursion has been plotted. The power-series solution was calculated by expanding the sinusoid into a power series and retaining the first two terms (Doppler rate and second derivative of Doppler). It is seen from the figure that the power-series solution is a close approximation to the actual solution during the initial 1/4 period. However, as soon as the approximation to the sinusoid breaks down, the power-series estimate diverges, whereas the actual solution remains bounded.

IV. Discussion

Expanding the Doppler signal into a Fourier series offers a different perspective in predicting the PLL performance. Unlike the power-series expansion method that, although intuitive, cannot adequately predict the performance under higher order perturbations, the periodic expansion of the Doppler results naturally in a periodic phase solution. As a result, the theory can predict a bounded solution even when the driving force (Doppler) has a higher order component. For applications where a good phase synchronization is essential, such as coherent data communications, the Fourier solution can provide an adequate estimate of the maximum phase-error excursion.

An example for the problem occurs in the design of the optical phase tracking loop between a low Earth-orbiting satellite and a ground station. At the operating wavelength of 1 μm , the relative Doppler rate of the two terminals can change from +300 MHz/sec to -300 MHz/sec within 30 seconds. Given a PLL of 20 kHz bandwidth, it is difficult to predict whether the loop can remain adequately in lock during the period. By approximating the Doppler signal near the portion of the orbit with maximum frequency change as a sinusoid, however, a simple estimate of the PLL performance can be obtained. For a frequency excursion with 3-GHz amplitude and 60-second period, it can be shown that the loop can adequately track the Doppler with less than 0.2 radian of residual error.

Although the Fourier expansion provides a bounded solution for a periodic varying Doppler signal, there are some

practical limitations in applying the Fourier analysis technique. First, the solution presented above ignores the transient solution. This is true only when the period of the dynamic signal is long compared to the loop-response time. Furthermore, the results are derived only for a linearized equation. For a nonlinear PLL equation, a periodic driv-

ing force can excite higher harmonic terms. Finally, for a predictable periodic driving force, it is a usual practice to apply a periodic estimator correction term at the VCO input to compensate for the periodic driving force. In this case, the detuning is small and the loop will essentially respond only to the noise inputs.

References

- [1] W. C. Lindsey and M. K. Simon, *Telecommunications Systems Engineering*, Englewood Cliffs, New Jersey: Prentice-Hall, 1973.
- [2] A. J. Viterbi, *Principles of Coherent Communications*, New York: McGraw-Hill, 1966.
- [3] J. J. Spilker, *Digital Communication by Satellite*, Englewood Cliffs, New Jersey: Prentice-Hall, 1977.
- [4] W. C. Lindsey, *Synchronization Systems in Communication and Control*, Englewood Cliffs, New Jersey: Prentice-Hall, 1972.
- [5] C. T. Chen, *Introduction to Linear System Theory*, New York: Holt, Rinehart and Winston, 1970.

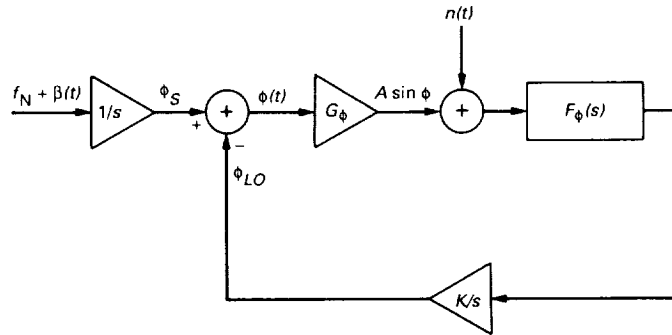

Fig. 1. Equivalent-noise block diagram of a carrier phase-locked loop.

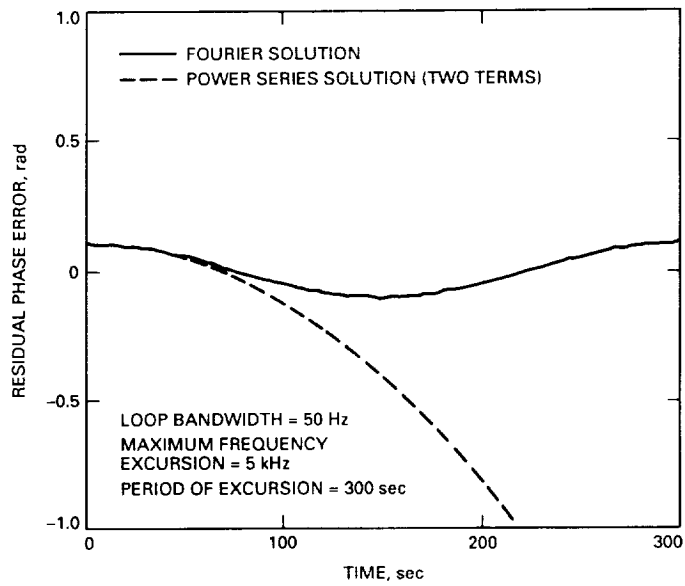

Fig. 2. Residual phase tracking error for a second-order phase-locked loop subjected to a periodic Doppler input. The PLL was analyzed by using the Fourier decomposition method and a power-series solution.