

TDA Progress Report 42-104

February 15, 1991

N91-18327

JJG 10/1/91

New Space Research Frequency Band Proposals in the 20- to 40.5-GHz Range

D. F. Bishop

Telecommunications Systems Section

Future space research communications systems may require spectra above 20 GHz. This article identifies frequency bands above 20 GHz that are suitable for space research. The selection of the proper bands depends on consideration of interference with other radio services, adequate bandwidths, link performance, and technical requirements for practical implementation.

I. Introduction

One of the areas of study in preparation for the World Administrative Radio Conference (WARC) of 1992 is the identification of bands above 20 GHz that could be used for space research. Figure 1 shows the existing allocations for space research (active) between 20 and 40.5 GHz. From Fig. 1, it can be seen that there are limited bands for space research. Therefore, a study was undertaken to identify additional bands between 20.0 and 40.5 GHz that are appropriate for space research. The criteria for selection of the new space research bands are provided. Several proposed frequency bands are chosen for consideration. Detailed band sharing studies between space research and existing services in these proposed bands are available.¹ Hardware considerations are discussed. Foot-

note 1 contains diagrams of hardware circuitry that can be used to provide coherence between the proposed space research bands and the existing space research allocations at 2 GHz (S-band) and 7 to 8 GHz (X-band).

II. Criteria for New Space Research Bands

Several criteria went into the selection of potential space research bands. Minimum bandwidths of 500 MHz were sought for all proposed bands. Only bands between 20 GHz and 40.5 GHz were considered. Passive sensor bands in the space research services and radio-astronomy services were avoided to protect their sensitive receivers. To use the same antenna for transmit and receive operation, a minimum frequency spacing of 7 percent was desired. Coherence between the new band proposals and existing space research allocations at 2 GHz (S-band) and 7 to 8 GHz (X-band) was desired. Minimal interference with existing services in the proposed bands was sought. Since even small rainfall rates cause significant link degra-

¹D. F. Bishop, "Background Material for Selection of New Space Research Frequency Bands Above 20 GHz," JPL Interoffice Memorandum 3396-90-90 (internal document), Jet Propulsion Laboratory, Pasadena, California, November 26, 1990.

dation at frequencies above 20 GHz, it was not considered practical to select bands above 20 GHz based on weather conditions. Therefore, the effects of rain and clouds were not considered. The band selection in this article is based on clear-weather performance.

III. Proposed Space Research Allocations

Based on the criteria of Section II, preliminary bands were selected as candidates for space research. Figures 2 and 3 show these bands. The band edges were selected to conform to the band edges that appear in the International Telecommunication Union (ITU) Table of Frequency Allocations ([1], page RR8-9). This was done to provide simple inclusion of a space research allocation should the proposal be accepted. Parts of these bands may not be suitable for space research due to hardware limitations or harmonic interference as demonstrated in the next section.

IV. Radio Frequency Interference Analysis

One of the criteria for the selection of new space research bands was to have minimal interference with existing services. The potential interference was shown by performing sharing analyses between existing services and space research in the bands shown in Figs. 2 and 3. Two different scenarios were used for the space research services. In the first scenario, the space research spacecraft was located at the L_1 Lagrangian (libration) point in the Earth-moon system [2]. Figure 4 contains an illustration of this scenario. In the second scenario, the space research spacecraft was located in a circular orbit around the Earth with an altitude of 500 km (Fig. 5). This is a typical orbit for a low Earth-orbiting spacecraft in the space research service.

Table 1 contains an example of a detailed sharing analysis. In this scenario, the 21.4- to 22.0-GHz band is proposed for space research in the space-to-Earth direction. In this frequency band there is a primary allocation for fixed and mobile services. Therefore, there is a potential for interference with a ground station in the space research service. Radio Regulation 2505 ([1], page RR27-2) permits a maximum Effective Isotropic Radiated Power (EIRP) of 55 dBW for a fixed or mobile service. This is the first entry on Table 1. The receiver bandwidth for a fixed radio relay system near 22 GHz is 40 MHz [3]. For simplicity, it is assumed that the total transmitter power is spread uniformly over this 40-MHz bandwidth; therefore, the spectral density level is -76.0 dB/Hz ($10 \cdot \log\{[40 \cdot 10^6]^{-1}\}$). This is the second entry on Table 1.

The third entry on Table 1 is the great-circle path loss. The great-circle path loss is selected to yield an interference margin of 0 dB in Table 1. The great-circle path loss determines a coordination distance [4]. A horizon angle of zero degrees is used. Larger horizon angles would yield lower interference levels at the Earth station receiver. Radio zone A2 is used. This zone contains Goldstone, California. The rate of attenuation due to all effects except atmospheric gases is determined for 0.001 percent of the time. This is the percentage of time that is recommended to protect deep-space research missions [5]. The result is that a coordination distance of 202 km between the fixed service transmitter and the space research Earth station is required.

The interference signal from the fixed service transmitter approaches the space research Earth station from the horizon. If it is assumed that the space research Earth station has an elevation angle of 10 degrees, then the gain of its antenna toward the horizon is 7 dBi ($32 - 25 \cdot \log[10]$) from the ITU reference pattern [6]. This is the fourth entry on Table 1. The first four entries on Table 1 are added to yield the interference level at the space research Earth station receiver. The space research Earth station interference criterion is set equal to the deep-space Earth station interference criterion [7] at 32 GHz since deep-space Earth station receivers are often used for near-Earth space research, and it is closest in frequency to this proposed band from 21.4 to 22.0 GHz. The difference between the interference criterion and the interference level is the interference margin. In this case, the interference margin is 0.0 dB. Recall that the great-circle path loss was selected to yield an interference margin of 0 dB. This is the desired value. Coordination distances of greater than 202 km would yield positive values of interference margin. Therefore, the fixed services can share the 21.4- to 22.0-GHz band with space research (space-to-Earth) if the coordination distance between the stations is greater than 202 km measured over a great-circle path.

Footnote 1 contains the detailed sharing analyses that were performed in all of the proposed bands for space research. A summary of these sharing analyses is contained in Tables 4 through 12. These tables indicate the proposed frequency band, existing services in that band, the source of interference, the interference victim, the coordination distance for terrestrial interference scenarios, and the interference margin.

During the course of the study, another constraint on proposed bands was added. It was suggested that avoidance of harmonic interference from current space research allocations at 2 GHz (S-band) and 7 to 8 GHz (X-band)

is necessary. Therefore, the harmonics of the 2-GHz (S-band) and 7- to 8-GHz (X-band) allocations for space research that exist above 20 GHz were investigated. The allocations for near-Earth and deep-space research were considered because deep-space research equipment is often used for near-Earth space research. Table 2 contains some of the harmonic frequencies for space research (Earth-to-space) bands. The tenth harmonic of the space research allocation at 2 GHz (S-band) that is shown in Table 2 is probably too small to interfere with services in the harmonic band. Higher order harmonics should be even lower. The harmonics of the space research allocation at 7 to 8 GHz (X-band) that are shown in Table 2 may be large enough to cause interference. Therefore, these harmonic bands should be avoided by space research services. Space research ground stations that receive at these frequencies would be especially vulnerable to uplink harmonic emissions.

Table 3 contains some of the harmonic frequencies for space research (space-to-Earth) bands. The ninth harmonic of the space research allocation at 2 GHz (S-band) that is shown in Table 3 is probably too small to interfere with services in the harmonic band. Higher order harmonics should be even lower. The harmonics of the space research allocation at 7 to 8 GHz (X-band) that are shown in Table 3 may be large enough to cause interference. Therefore, these harmonic bands should be avoided by space research services. Space research spacecraft that receive at these frequencies would be especially vulnerable to these downlink harmonic emissions.

V. Hardware Considerations

Hardware characteristics influence the selection of new bands for space research. Hardware design personnel indicated that a minimum spacing of 7 to 8 percent between the uplink and downlink frequencies is required to build practical diplexers. The use of a diplexer allows the same antenna to be used for uplink and downlink. The diplexer restricts the maximum spacing between uplink and downlink frequencies to 50 percent. Typically, space research services use circularly polarized signals. These circular polarizers limit the maximum spacing between uplink and downlink frequencies to 20 percent. Therefore, if a diplexer and a circular polarizer are used, the frequency spacing between uplink and downlink should be between 8 and 20 percent.

An additional hardware requirement is that the new space research allocations must be coherent with the existing allocations at 2 GHz (S-band) and 7 to 8 GHz

(X-band). The requirement is that the 2-GHz (S-band) downlink, the 7- to 8-GHz (X-band) downlink, and the new downlink (above 20 GHz) must be derived by the spacecraft transponder from the new uplink (above 20 GHz). Figure 6 contains an example of a circuit² that can provide coherence between the downlink frequencies and the uplink frequency. The uplink frequency of 24.46 GHz is within the proposed band of 24.25 to 25.25 GHz for space research (Earth-to-space). The circuitry derives an output frequency, F_a ($4 \cdot 20.18$ MHz). This frequency is used as an input for three multiplier chains that derive the three downlink frequencies. The first downlink frequency of 27.77 GHz is within the proposed band of 27.5 to 29.5 GHz for space research (space-to-Earth). The second downlink frequency of 8.48 GHz is within the 8.45- to 8.50-GHz band for space research (space-to-Earth). The third downlink frequency of 2.26 GHz is within the 2.20- to 2.29-GHz band for space research (space-to-Earth). Therefore, coherence between the downlinks and the uplink has been provided. Additional circuits that provide coherence for spacecraft transponders are contained in Footnote 1.

VI. Preferred Bands for Space Research

A comparison of link performance for the proposed space research bands in Figs. 2 and 3 was conducted in [8]. The conclusion was that the bands above 30 GHz provided improved link performance compared to the bands between 20 and 30 GHz. The downlink had up to 1-dB improvement and the uplink had up to 4.7-dB improvement. Above 30 GHz, the 30.0- to 31.3-GHz band (downlink) would be paired with the 34.2- to 35.2-GHz band (uplink) and the 37.0- to 37.5-GHz band (downlink) would be paired with the 39.5- to 40.5-GHz band (uplink).

Interference with other radio services in the 30.0- to 31.3-GHz band is minimal. The worst case interference occurs to a standard frequency and time signal satellite (SFTSS) Earth station from a low Earth-orbit space research satellite. In this case, there could be up to 26.5 seconds of interference during the worst orbit. All interference scenarios have low probabilities of occurrence.

In the 34.2- to 35.2-GHz band, there are some cases where interference can occur. Coordination of airborne-mobile or airborne-radiolocation stations in sight of space research stations is not practicable. Space research spacecraft within sight of terrestrial radiolocation stations

² Transponder circuits provided by C. E. Johns of the Radio Frequency and Microwave Subsystems Section, Jet Propulsion Laboratory, Pasadena, California.

would receive severe interference. Coordination of frequency assignments would be a method to reduce interference. In the 37.0- to 37.5- and 39.5- to 40.5-GHz bands, coordination distances are small enough that sharing between space research and other services is possible. Coordination with airborne stations is not practicable. Otherwise, the interference potential is minimal.

VII. Summary and Conclusions

A search of the 20.0- to 40.5-GHz band has been made to identify frequency bands that may be used for space research. The criteria used for selection of the proposed bands are indicated. Several potential frequency bands are presented. Detailed band-sharing studies between space research and existing services in these proposed bands are provided in Footnote 1. Hardware constraints are discussed. Footnote 1 contains diagrams of hardware circuitry that can be used to provide coherence between the proposed space research bands and the existing space research allocations at 2 GHz (S-band) and 7 to 8 GHz (X-band). Lastly, preferred frequency bands for space research in the 20.0- to 40.5-GHz range are indicated.

Considering link performance and hardware implementation, the following band pairs are recommended for the space research service in the 20.0- to 40.5-GHz range:

30.0 to 31.3 GHz space research, space-to-Earth, primary in all three ITU regions, and

34.7 to 35.2 GHz space research, Earth-to-space, primary in all three ITU regions

or:

37.0 to 37.5 GHz space research, space-to-Earth, primary in all three ITU regions, and

39.5 to 40.5 GHz space research, Earth-to-space, primary in all three ITU regions.

From a hardware standpoint, the first band pair has the advantage of proximity to existing deep-space research allocations at 31.8 to 32.3 GHz and 34.2 to 34.7 GHz. However, the second band pair has a lower potential for interference with other radio services.

References

- [1] *International Telecommunication Union Radio Regulations*, ISBN 92-61-01221-3, vol. 1, 1982.
- [2] J. Hall and J. Sos, "Preliminary Assessment and Implementation Plan for NASA Office of Exploration, Human Exploration Case Studies," MERTS Submission, *Space Frequency Coordination Group, Eighth Annual Meeting*, Buenos Aires, Argentina, 1988, Document SF/8-28, Section 3, p. 7, July 1988.
- [3] M. J. Pagonis, W. D. Rummler, and W. J. Vidinski, "Protection of Terrestrial Line-of-Sight Radio-Relay Systems Against Interference from Space Stations in the Fixed-Satellite Service in Shared Frequency Bands Between 1 and 23 GHz," proposed revisions to *International Radio Consultative Committee (CCIR) Report 387-5*, CCIR Study Group 4/9, Document 01234567, CCIR, Geneva, Switzerland, p. 4, March 12, 1987.
- [4] CCIR, "Propagation Data Required for the Evaluation of Coordination Distance in the Frequency Range 1-40 GHz," *Recommendations and Reports of the CCIR, vol. V, Propagation in Non-Ionized Media*, CCIR Report 724-2, CCIR, Geneva, Switzerland, p. 485, 1986.
- [5] CCIR, "Protection Criteria and Sharing Considerations Relating to Deep-Space Research," CCIR Recommendation 578, *Recommendations and Reports of the CCIR, vol. II, Space Research and Radioastronomy*, CCIR, Geneva, Switzerland, p. 270, 1986.

- [6] *International Telecommunication Union Radio Regulations*, ISBN 92-61-01221-3, vol. 2, p. AP29-14, 1982.
- [7] CCIR, "Protection Criteria and Sharing Considerations Relating to Deep-Space Research," CCIR Report 685-2, *Recommendations and Reports of the CCIR, vol. II, Space Research and Radioastronomy*, CCIR, Geneva, Switzerland, Table IV, p. 282, 1986.
- [8] N. F. de Groot, *New Space Research Allocations in the 20-40 GHz Range*, United States Study Group for CCIR, Interim Working Party 2/2, draft report, CCIR, Geneva, Switzerland, p. 4, July 6, 1990.

Table 1. Sharing analysis between fixed and mobile services and space research in the 21.4- to 22.0-GHz band

Interference to a space research Earth station	
Fixed or mobile station EIRP (maximum allowed – ITU RR2505)	55.0 dBW
Spectral density level (uniform spectrum – 40-MHz bandwidth [3])	–76.0 dB/Hz
Great-circle path loss (202 km, $A_h = 0$, zone A2, 0.001% of time)	–203.3 dB
Space research Earth station antenna gain toward the horizon (10-deg elevation angle, CCIR pattern)	7.0 dB
Interference level at space research Earth station receiver	–217.3 dBW/Hz
Space research interference criterion	–217.3 dBW/Hz
Interference margin	0.0 dB

Table 2. Harmonic bands for space research (Earth-to-space)

Space research allocation band, GHz	Harmonic number	Harmonic band, GHz
2.025 – 2.120	10	20.25 – 21.20
7.145 – 7.235	3	21.435 – 21.705
7.145 – 7.235	4	28.58 – 28.94
7.145 – 7.235	5	35.72 – 36.18
7.145 – 7.235	6	42.87 – 43.41

Table 3. Harmonic bands for space research (space-to-Earth)

Space research allocation band, GHz	Harmonic number	Harmonic band, GHz
2.20 – 2.30	9	19.80 – 20.70
8.40 – 8.50	3	25.20 – 25.50
8.40 – 8.50	4	33.60 – 34.00
8.40 – 8.50	5	42.00 – 42.50

Table 4. Summary of sharing analysis for 21.4 to 22.0 GHz for space research (space-to-Earth)

Existing services	Interference source	Interference victim	Coordination distance, km	Interference margin, dB
Fixed and mobile	Fixed or mobile	Space research Earth station	202	0.0
	Space research spacecraft, Case 1	Fixed or mobile	—	24.8
	Space research spacecraft, Case 2	Fixed or mobile	—	–12.4

Table 5. Summary of sharing analysis for 23.0 to 23.6 GHz for space research (Earth-to-space)

Existing services	Interference source	Interference victim	Coordination distance, km	Interference margin, dB
Fixed and mobile	Fixed or mobile	Space research spacecraft, Case 1	—	8.7
	Fixed or mobile	Space research spacecraft, Case 2	—	–28.5
	Space research Earth station	Fixed or mobile	250.4	0.0
Intersatellite	Relay satellite	Space research spacecraft, Case 1	—	–2.3
	Relay satellite	Space research spacecraft, Case 2	—	–22.2
	Space research Earth station	Intersatellite satellite	—	–113.4

Table 6. Summary of sharing analysis for 24.25 to 25.25 GHz for space research (Earth-to-space)

Existing services	Interference source	Interference victim	Coordination distance, km	Interference margin, dB
Radio navigation	Radio navigation	Space research spacecraft, Case 1	—	-6.3
	Radio navigation	Space research spacecraft, Case 2	—	-31.9
	Space research Earth station	Radio navigation	331	0.0

Table 7. Summary of sharing analysis for 25.25 to 27.0 GHz for space research (space-to-Earth)

Existing services	Interference source	Interference victim	Coordination distance, km	Interference margin, dB
Data relay satellite (candidate band)	Space research spacecraft	Data relay satellite	—	-11.5
	User (low Earth orbit) of data relay satellite	Space research Earth station	—	-63.6

Table 8. Summary of sharing analysis for 27.5 to 29.5 GHz for space research (space-to-Earth)

Existing services	Interference source	Interference victim	Coordination distance, km	Interference margin, dB
Fixed satellite (E-S)	Fixed satellite Earth station	Space research Earth station	142.6	0.0
	Space research spacecraft, Case 1	Fixed satellite (geostationary)	—	17.0
	Space research spacecraft, Case 2	Fixed satellite (geostationary)	—	-1.4
Fixed and mobile	Fixed or mobile	Space research Earth station	196	0.0
	Space research spacecraft, Case 1	Fixed or mobile	—	24.8
	Space research spacecraft, Case 2	Fixed or mobile	—	-12.4

Table 9. Summary of sharing analysis for 30.0 to 31.3 GHz for space research (space-to-Earth)

Existing services	Interference source	Interference victim	Coordination distance, km	Interference margin, dB
Fixed satellite (E-S), mobile satellite (E-S)	Fixed satellite Earth station	Space research Earth station	138.6	0.0
	Space research spacecraft, Case 1	Fixed satellite (geostationary)	—	17.0
SFTSS ^a (S-E)	Space research spacecraft, Case 2	Fixed satellite (geostationary)	—	56.6
	SFTSS satellite	Space research Earth station	—	-24.6
	Space research spacecraft, Case 1	SFTSS Earth station	—	8.9
	Space research spacecraft, Case 2	SFTSS Earth station	—	-47.4
Fixed and mobile	Fixed or mobile	Space research Earth station	192	0.0
	Space research spacecraft, Case 1	Fixed or mobile	—	24.8
	Space research spacecraft, Case 2	Fixed or mobile	—	-12.4

^a Standard frequency and time signal satellite.

Table 10. Summary of sharing analysis for 34.7 to 35.2 GHz for space research (Earth-to-space)

Existing services	Interference source	Interference victim	Coordination distance, km	Interference margin, dB
Fixed and mobile	Fixed or mobile	Space research spacecraft, Case 1	—	16.1
	Fixed or mobile	Space research spacecraft, Case 2	—	-21.1
	Space research Earth station	Fixed or mobile	273.1	0.0
Radiolocation	Radiolocation	Space research spacecraft, Case 1	—	-7.6
	Radiolocation	Space research spacecraft, Case 2	—	-63.9
	Space research Earth station	Radiolocation	342.5	0.0

Table 11. Summary of sharing analysis for 37.0 to 37.5 GHz for space research (space-to-Earth)

Existing services	Interference source	Interference victim	Coordination distance, km	Interference margin, dB
Fixed satellite (E-S)	Fixed satellite Earth station	Space research Earth station	120	0.0
	Space research spacecraft, Case 1	Fixed satellite (geostationary)	—	17.0
	Space research spacecraft, Case 2	Fixed satellite (geostationary)	—	58.3
Fixed and mobile	Fixed or mobile	Space research Earth station	168.5	0.0
	Space research spacecraft, Case 1	Fixed or mobile	—	24.8
	Space research spacecraft, Case 2	Fixed or mobile	—	3.5

Table 12. Summary of sharing analysis for 39.5 to 40.5 GHz for space research (Earth-to-space)

Existing services	Interference source	Interference victim	Coordination distance, km	Interference margin, dB
Fixed satellite (S-E), mobile satellite (S-E)	Fixed satellite (geostationary)	Space research spacecraft, Case 1	—	11.2
	Fixed satellite (geostationary)	Space research spacecraft, Case 2	—	41.6
	Space research Earth station	Fixed satellite Earth station	198.8	0.0
Fixed and mobile	Fixed or mobile	Space research spacecraft, Case 1	—	16.1
	Fixed or mobile	Space research spacecraft, Case 2	—	7.2
	Space research Earth station	Fixed or mobile	238.2	0.0

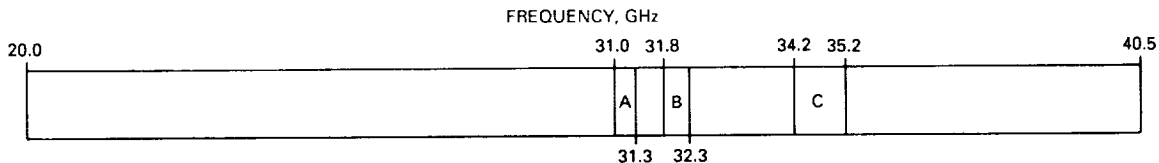

- BAND A: 31.0 TO 31.3 GHz**
1. SECONDARY, WORLDWIDE ALLOCATION FOR SPACE RESEARCH
 2. PRIMARY ALLOCATION FOR SPACE RESEARCH IN BULGARIA, CUBA, HUNGARY, MONGOLIA, POLAND, THE GERMAN DEMOCRATIC REPUBLIC, CZECHOSLOVAKIA, AND THE U.S.S.R.
- BAND B: 31.8 TO 32.3 GHz**
1. SECONDARY, WORLDWIDE ALLOCATION FOR SPACE RESEARCH
 2. PRIMARY ALLOCATION FOR DEEP SPACE RESEARCH (SPACE-TO-EARTH) IN AUSTRALIA, SPAIN, AND THE UNITED STATES
 3. PRIMARY ALLOCATION FOR SPACE RESEARCH IN BULGARIA, CUBA, HUNGARY, MONGOLIA, POLAND, THE GERMAN DEMOCRATIC REPUBLIC, CZECHOSLOVAKIA, AND THE U.S.S.R.
- BAND C: 34.2 TO 35.2 GHz**
1. SECONDARY, WORLDWIDE ALLOCATION FOR SPACE RESEARCH
 2. PRIMARY ALLOCATION FOR DEEP SPACE RESEARCH (EARTH-TO-SPACE) IN AUSTRALIA, SPAIN, AND THE UNITED STATES IN THE 34.2- TO 34.7-GHz BAND
 3. PRIMARY ALLOCATION FOR SPACE RESEARCH IN BULGARIA, CUBA, HUNGARY, MONGOLIA, POLAND, THE GERMAN DEMOCRATIC REPUBLIC, CZECHOSLOVAKIA, AND THE U.S.S.R.

Fig. 1. Existing space research (active) allocations (20 GHz to 40.5 GHz).

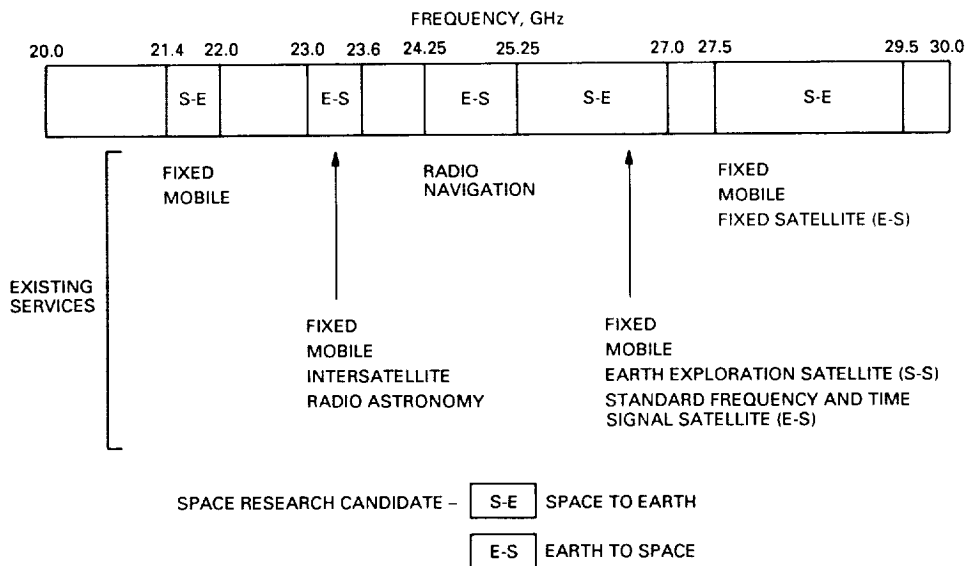

Fig. 2. Candidate bands for space research sharing analysis, 20- to 30-GHz range.

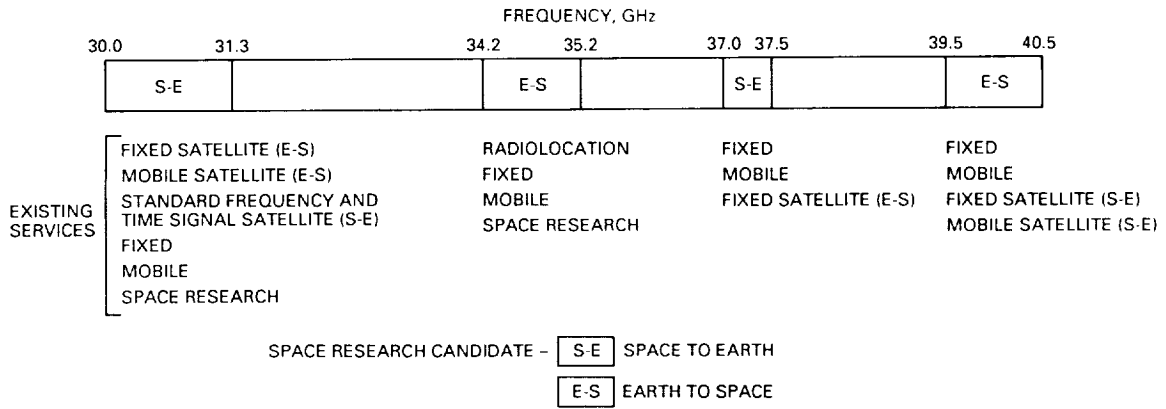

Fig. 3. Candidate bands for space research sharing analysis, 30- to 40.5-GHz range.

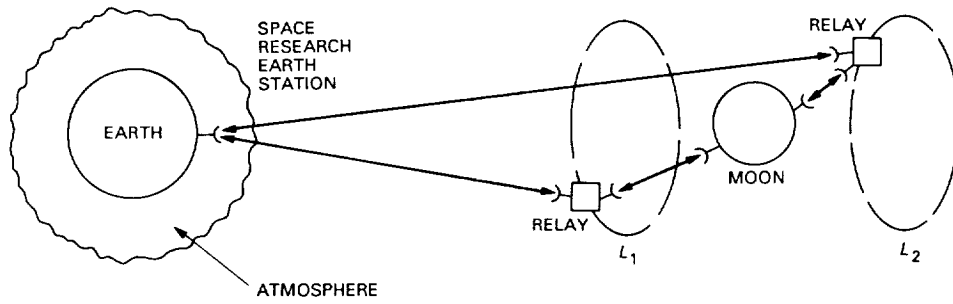

Fig. 4. Space research spacecraft located near the Moon.

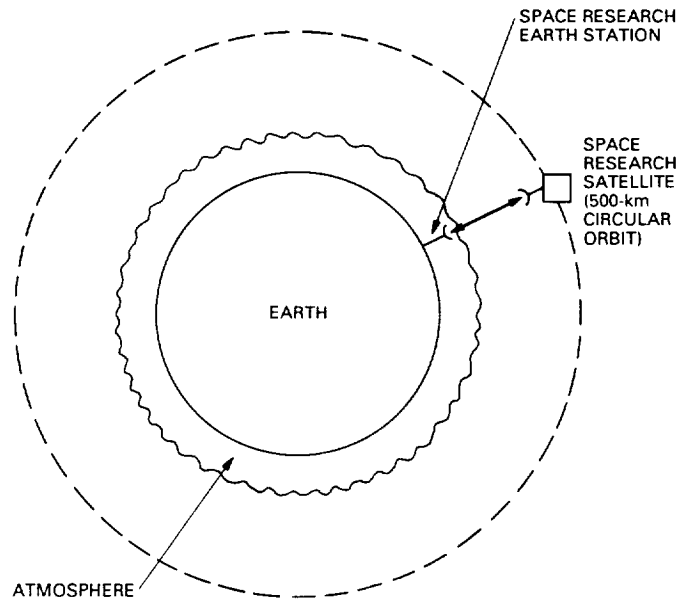
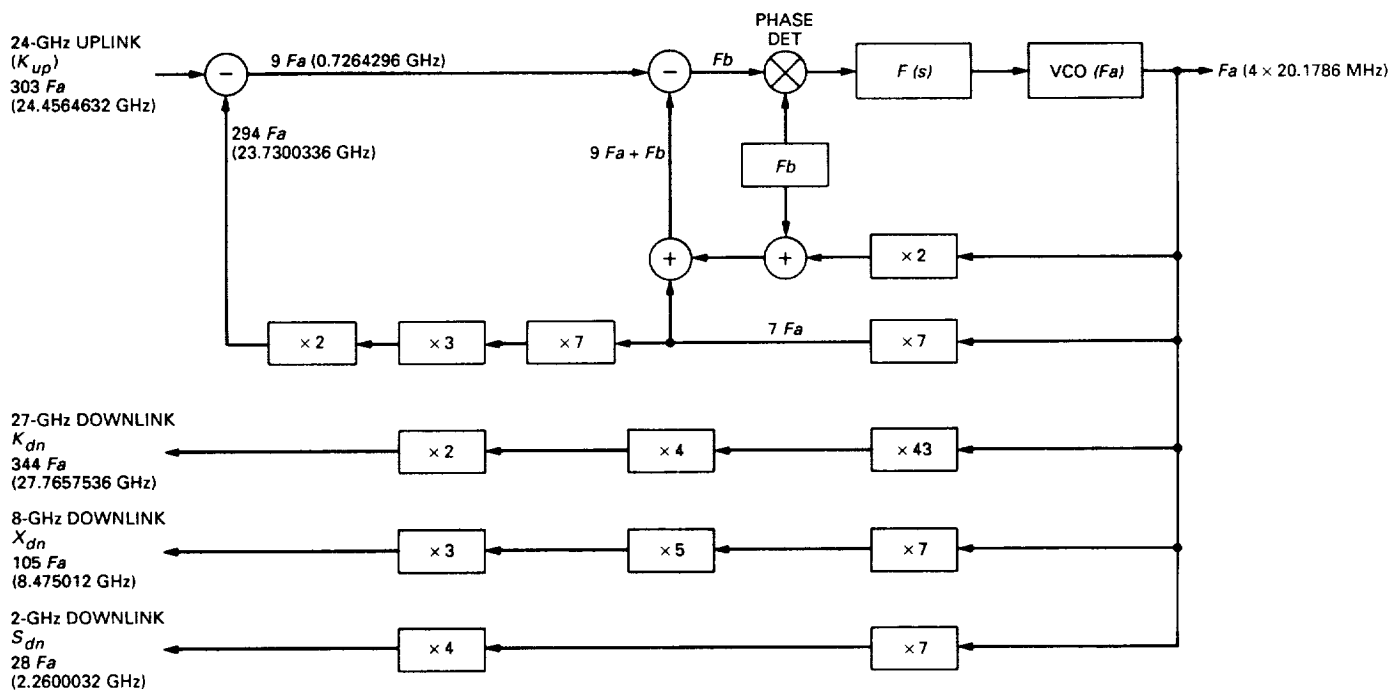

Fig. 5. Space research spacecraft located in low Earth orbit.



24- TO 27-GHz (K-BAND) TRANSPONDER NO. 1

FREQUENCY RATIOS:
 24-GHz UPLINK/27-GHz DOWNLINK = 303/344 24-GHz UPLINK/2-GHz DOWNLINK = 303/28
 24-GHz UPLINK/8-GHz DOWNLINK = 303/105 8-GHz DOWNLINK/2-GHz DOWNLINK = 900/240 (15/4)

Fig. 6. Example of a circuit used to provide coherence between the space research uplink and the downlinks.