

my

N91-19145-359  
330  
-19

# INNOVATIONS IN DYNAMIC TEST RESTRAINT SYSTEMS

Christopher J. Fuld  
McDonnell Douglas Space Systems Company

MP 628383

## ABSTRACT

Recent launch system development programs have led to a new generation of large scale dynamic tests. The variety of test scenarios share one common requirement: restrain and capture massive high velocity flight hardware with no structural damage. The Space Systems Laboratory of McDonnell Douglas Space Systems Company in Huntington Beach Ca. has developed a remarkably simple and cost effective approach to such testing using ripstitch energy absorbers adapted from from the sport of technical rockclimbing. The proven system reliability of the capture system concept has led to a wide variety of applications in test system design and in aerospace hardware design.

## INTRODUCTION

Falling is a common occurrence in sport rock climbing. As a result, technical rock climbing safety systems have reached extremely high levels of reliability and simplicity. A climber's restraint system consists essentially of a rope and its anchors. The rope serves as a high strength energy dissipation system which effectively limits restraint forces. Specialized devices, ripstitch energy absorbers, further augment the force limiting capabilities of the system. The climber skillfully integrates the parameters of his situation with safety system elements to form a system which assures a "safe motion envelope" should a fall occur.

DAC 104387

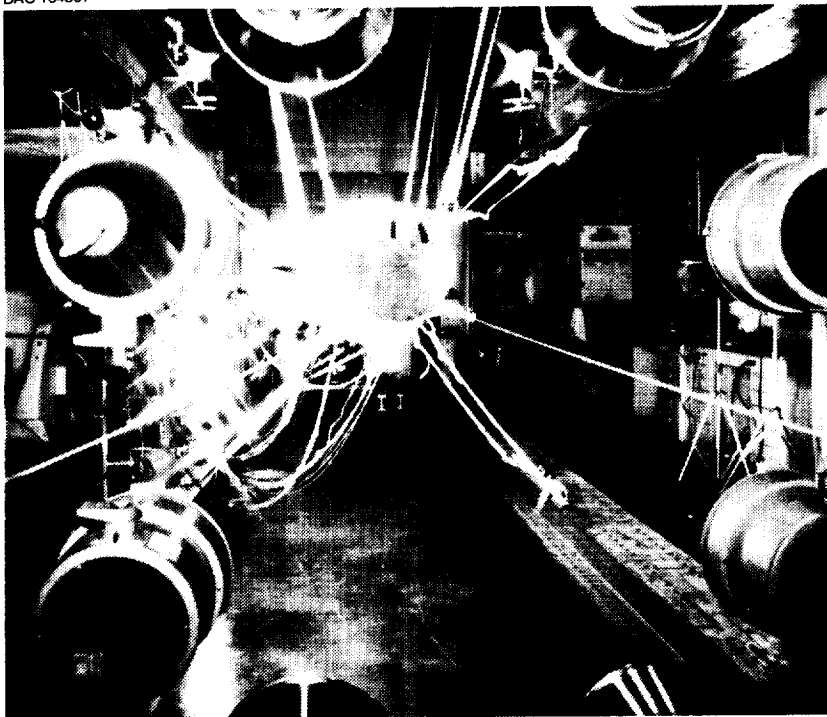

SSC 113446

103216



Restraint System Design is Applicable to a Wide Variety of Test Applications

ORIGINAL PAGE  
BLACK AND WHITE PHOTOGRAPH

ORIGINAL PAGE IS  
OF POOR QUALITY

An analogous challenge exists in aerospace dynamic testing. Test articles must be exercised and captured within a safe motion envelope large enough to record pertinent dynamic response data. Structures must be restrained in a controlled force manner. The test engineer integrates high reliability restraint elements with a wide variety of system parameters to assure success. These parameters include the test article, the safe motion envelope, test data parameters and the restraint system itself.

## THE TEST ARTICLE

### Kinematic and Mass Properties

Restraint systems apply external forces to control and ultimately bring to rest the test article. The motions of the test article before during and after the application of the restraint forces are all equally important. The initial free motion of the test article involves some combination of translation, roll, pitch and yaw velocities and accelerations. The restraint system applies a set of forces which modify the motions of the test article. The magnitude and location of the restraining forces determine the resulting kinematic properties of the test article (Figure 1).

103185

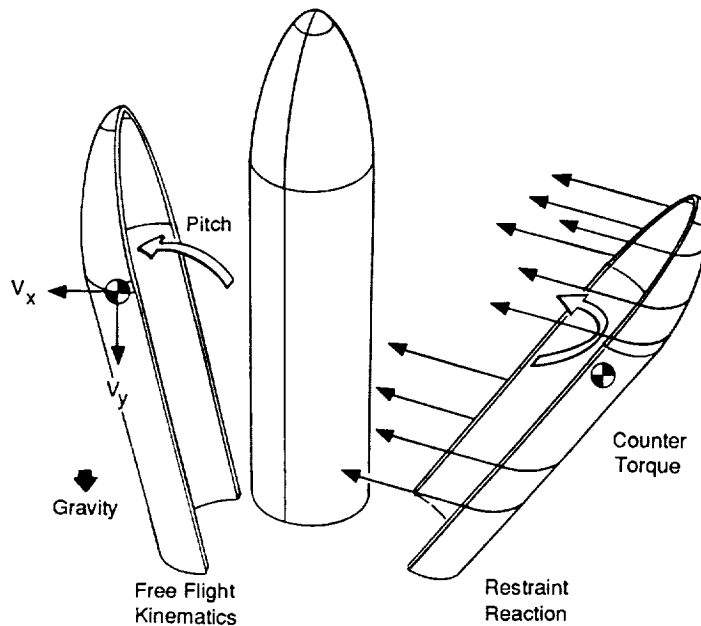

Figure 1. Dynamic Test Kinematics

The mass and kinematic properties of large test articles result in great restraint system design challenges. Large fairing structures have enormous moments of inertia and significant angular velocities. Angular velocities are reduced by applying restraint forces which generate a counter torque (and hence an angular acceleration) which suitably positions the body at rest. Computer modeling has proven quite helpful in simulating the dynamic response of the system.

### Structural Strength

The test article structural strength must be considered from the standpoint of restraint system loading. Aerospace structures are designed for optimum strength to weight ratios, hence reverse

loading situations encountered in restraint situations tend to load structures in their weakest mode. While single point loading (as incurred with rebound restraint systems) can present real problems, the distributed nature and loading magnitudes of primary restraint systems have proven in our applications to be orders of magnitude less than the loadings incurred during the ordnance separation event.

### **SAFE MOTION ENVELOPE/ TEST DATA PARAMETERS**

Dynamic motion tests are performed to gather pyroshock and flexible body motion data. While shock event is completed relatively soon after the separation event, motion data is usually significant for a period of time thereafter (depending on the natural frequency of the test article). As this freeflight time is typically on the order of .25-.5 seconds, the test article must translate for an appreciable distance, .45-1.5 meters (1.5-5 feet), to allow for high speed camera and strain gage data acquisition prior to restraint system engagement. The safe free motion and catch envelope is thus tailored to this data constraint and the external geometries of associated facilities and support structure. Restraint loading and free motion parameters are hence variables to be optimized.

### **RESTRAINT SYSTEM ELEMENTS**

Restraint system design involves predicting system behavior and then designing for beyond envelope margin. The Space Systems Laboratory has extensively tested system elements to fully characterize element performance.

### **Rip-Stitch Energy Absorbers (Figure 2)**

While rip-stitch energy absorbers (or rippers) are nothing new to climbers, the application of the device to test is somewhat novel. A length of webbing folded over and stitched appropriately, the shock loaded ripper tears the stitches at a constant mean force level, and in the process absorbs energy. Altering the thread material, thickness or stitch pattern alters the tear force. Modern industrial sewing machines are capable of mass-producing low cost assemblies with impressive tear out force repeatability ( $\pm 5\%$ ) at a low unit cost (\$10 and up).

SSC 113445

103218

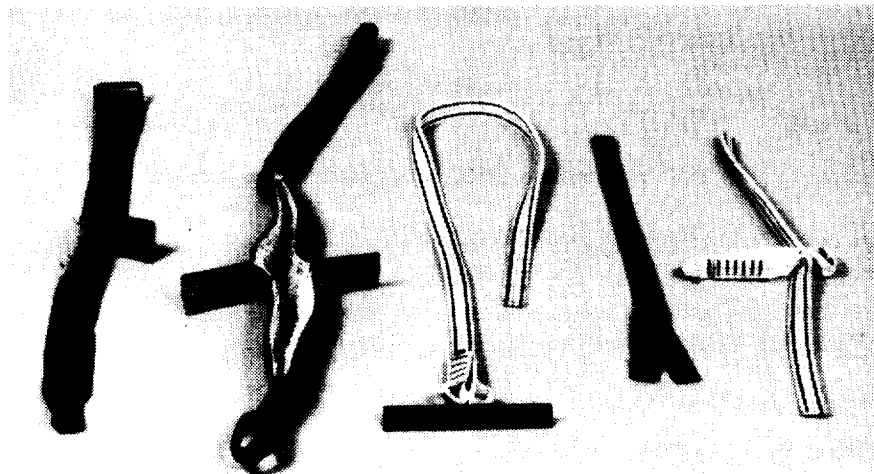

**Figure 2. Ripstitch Energy Absorber Assemblies**

ORIGINAL PAGE  
BLACK AND WHITE PHOTOGRAPH

ORIGINAL PAGE IS  
OF POOR QUALITY

## How Rip-Stitch Energy Absorbers Work

Rippers absorb energy through the classic work equation:

$$E = \int_{x=0}^{x=S} F \cdot dx$$

where

- E = net energy dissipated by the ripper
- F = mean ripper tear force
- S = total ripper tear out distance

07/30/90

Ripper assemblies are sewn in a variety of force values, tear out distances and stitch patterns. Overall average rip force levels for readily available single assemblies range from approximately 445-4450 Newtons (100 lb<sub>f</sub> to 1000 lb<sub>f</sub>). Arrest force values can be increased by employing parallel ripper assemblies. Such arrangements amplify the force in a relationship dependant on the assemblies stitch pattern.

### Rip-Stitch Energy Absorbers Stitch Pattern

Ripper stitch patterns vary between manufacturers. Typical stitching methods include bar tacks sewn normal to the webbing in long stripes, bar tacks sewn perpendicular to the webbing, and sinusoidal stitch patterns. Rip stitch energy absorber force profiles are unique to the type of stitch pattern (Figure 3).

103176.1M4DD

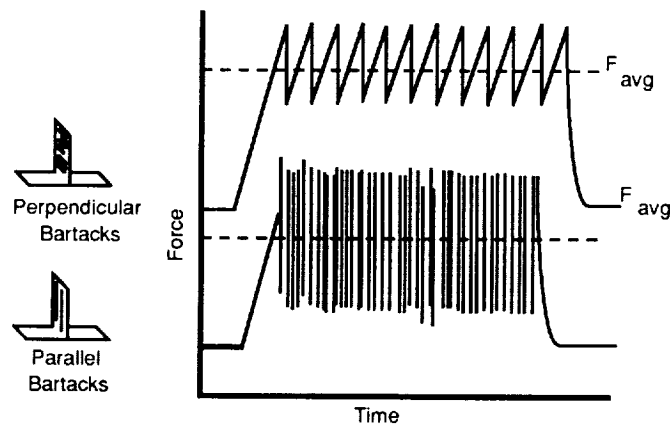

Figure 3. Ripstitch Energy Absorber Force Profiles

Most restraint applications are insensitive to energy absorber frequency response, hence stitch patterns are usually not a significant system design issue. One exception occurs in parallel ripper arrangements (to amplify restraint force). Ripper elements utilizing perpendicular bar tacks may demonstrate a 'phasing' effect which reduces the system restraint force (Figure 4).

### Rip-Stitch Energy Absorber Testing

While high speed data acquisition has been successfully employed to measure ripper tear out force, a simple evaluative test has been devised by SSL to characterize vendor shipments and validate uniformity. The method employs a simple vertical drop test utilizing a known rigid weight

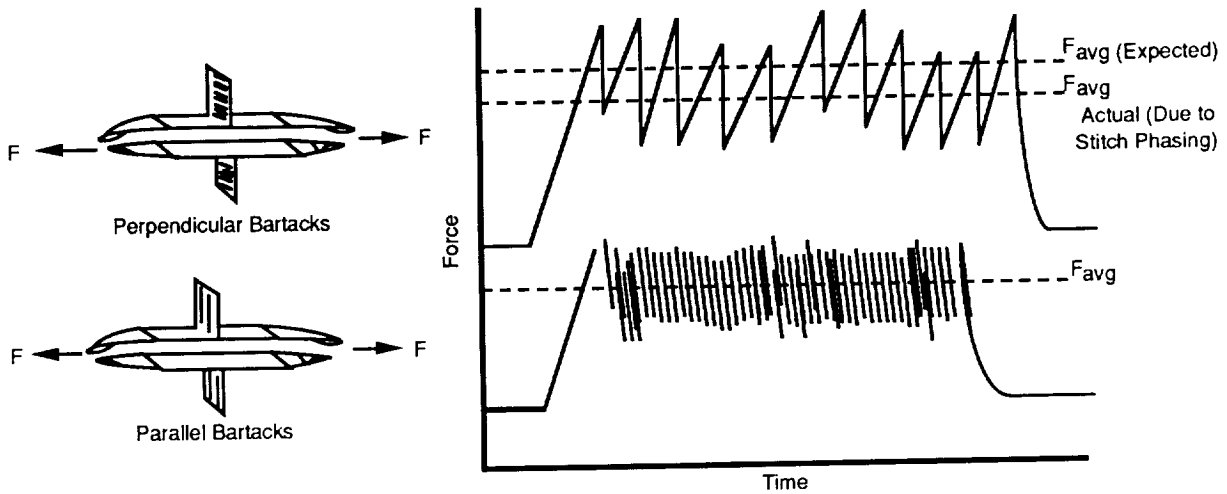

Figure 4. Parallel Ripstitch Energy Absorber Force Profiles

with measured freefall and tear out distances (Figure 5). The relationship of net ripper force to the measured setup distances can be shown to be:

$$F = \frac{(W \times D)}{S} + W$$

- F = average ripper force
- W = weight of rigid drop mass
- D = total mass free fall distance
- S = total ripper tearout distance

: 07/27/90

103174 3DM

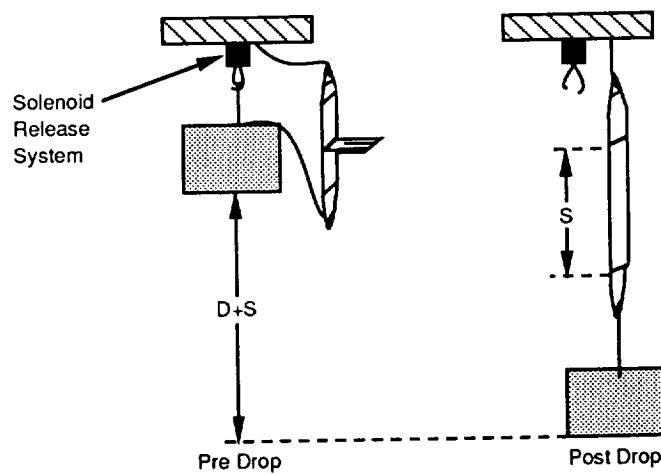

Figure 5. Energy Absorber Drop Test Approach

## Restraint System Strength and Elasticity

Rippers, webbing and rope are typically fabricated from synthetic materials such as nylon or polyester fiber. Such software possesses impressive strength and an elastic behavior defined by the chemistry of the fiber and the weave of the assembly. Rip stitch energy absorbers limit element loading to levels determined by the test article, kinetic energy, safe catch envelope and the amount of residual stored energy in the system.

In normal situations, rip stitch energy absorbers limit the amount of stored spring energy in the system (due to inherent elasticity) to extremely low levels. The amount of stored energy resulting from elasticity is a function of the system spring constant and effective damping resulting from the assembly. Measurement of these parameters has been achieved through modeling tests involving the spring/damper system during transient oscillatory motion (Figure 6). System stored energy is an obvious consideration; large tests such as the Titan 86 Foot PLF Separation Test required extensive analysis.

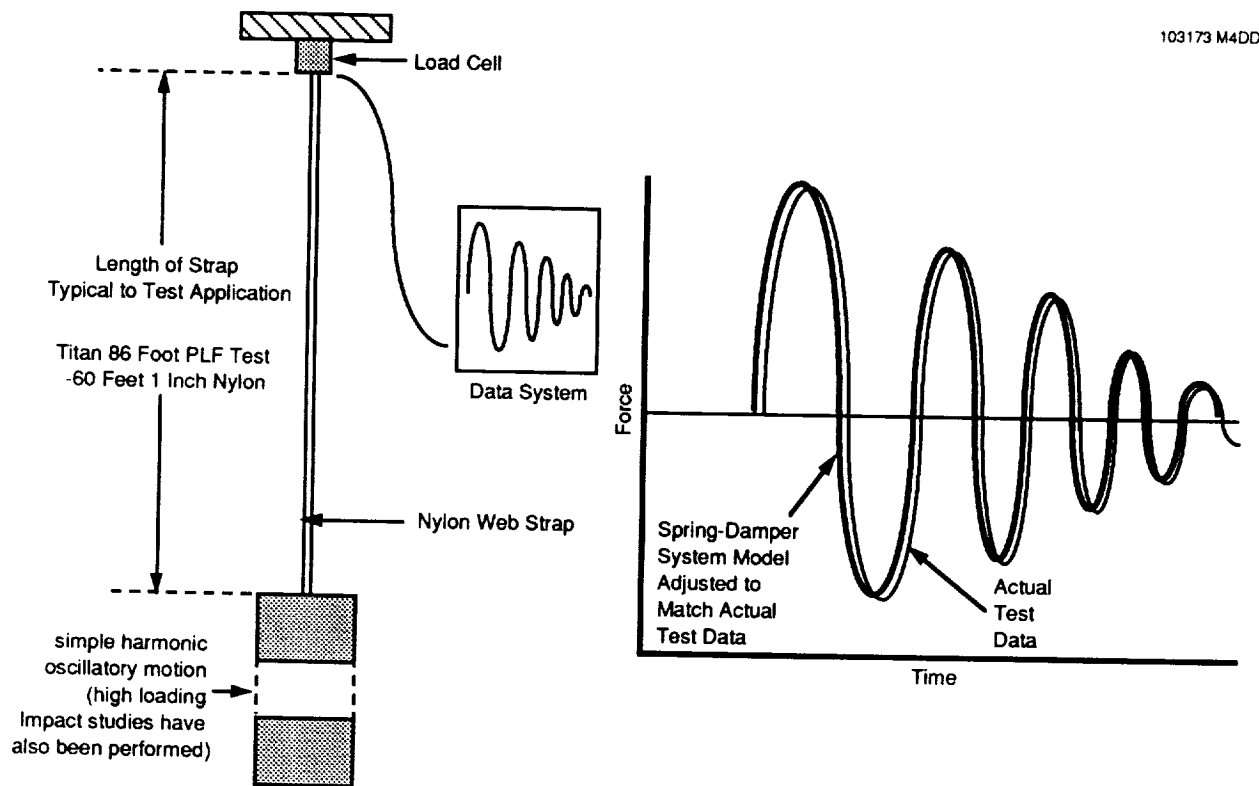

Figure 6. Experimental Technique To Measure Restraint System Element Kinematic Properties

Elasticity is not a completely undesirable element in restraint systems. Elasticity preserves an extra safety factor; should an off margin scenario occur, the fiber elements absorb an incredible amount of energy during impact stretching. The importance of rebound restraint systems increases in these situations.

## Rebound Restraint

Dynamic restraint systems are always designed to accommodate an off-nominal event, indeed such possibilities justify testing. As such occurrences raise the likelihood of increased stored

energy, the limiting of rebound effects is essential. Rebound limiting is accomplished by applying a benign restraining force to the test article in a manner which is conducive to the overall test requirements.

Some tests have utilized gravity to limit rebound. The HEDI 1D018A Interstage separation test employed a unique overhead suspension system which utilized gravity to mitigate rebound effects (Figure 7). The Modified Titan PLF separation test utilized an overhead compound pendulum suspension technique to dampen rebound (Figure 8).

103172 M7DD

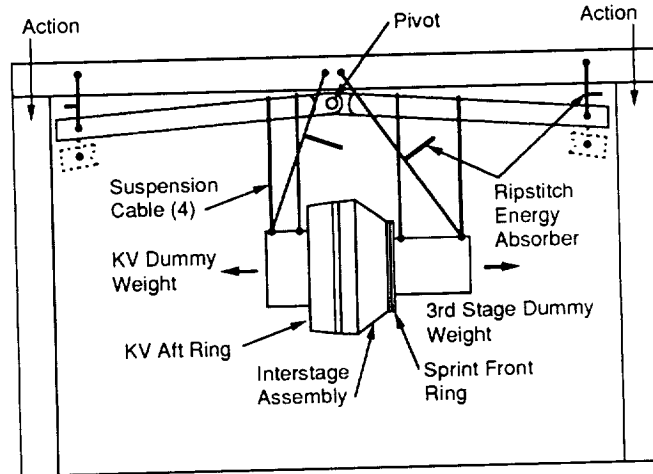

Figure 7. HEDI 1D018A Overhead Suspension System

DAC 906423

103219

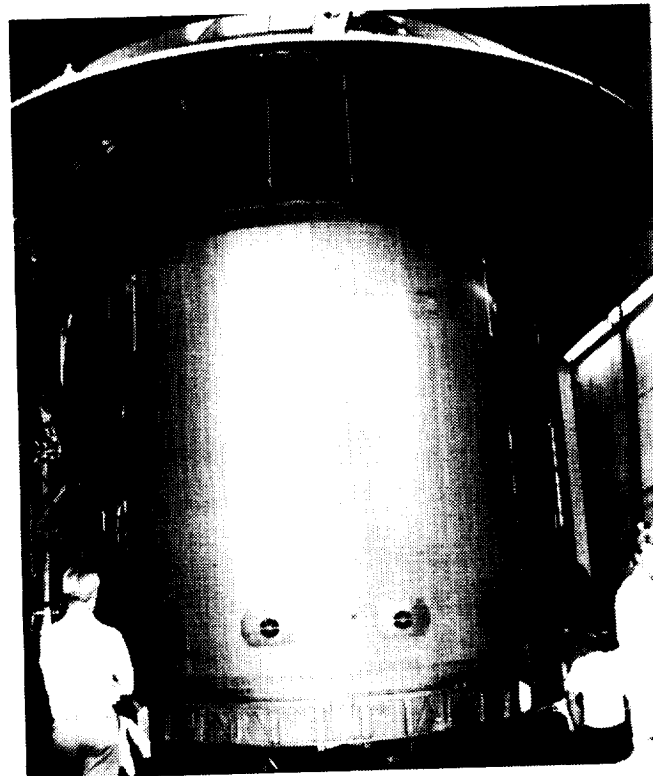

Figure 8. Titan Overhead Compound Pendulum Suspension

Active retracting clutch systems have been used with complete success by SSL. Nylon ropes are suitably attached to the test article and routed to pulleys and rope clutches (Figure 9). A tensioned bungee cord propels the systems during test to prevent excessive rope slack. The clutches engage during rebound and limit control resulting motion. Engagement shock is significantly reduced by integrating a ripper in the retractor line.

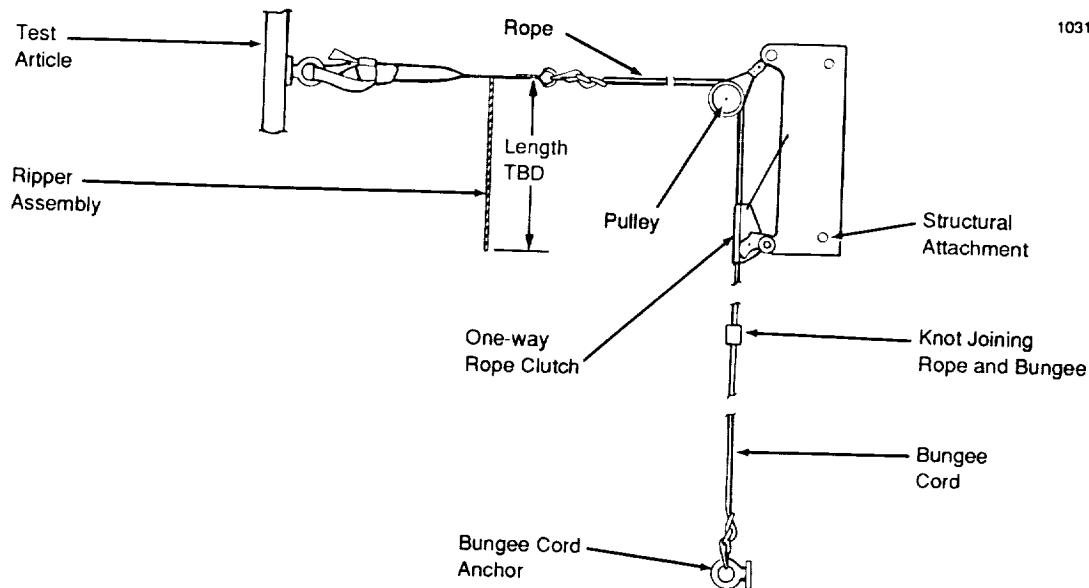

Figure 9. Active Rebound Restraint System

## TEST APPLICATIONS

### HEDI 1D018A Interstage Separation Test, 19 July 1988 (Figure 10)

#### Test Article Specifications

Length: Interstage: 0.58 m (1.95 ft)

Kill Vehicle (KV): 0.54 m

Diameter: 0.5 m (1.6 ft) nominal

Weight: Interstage – 407 kg (898 lb) KV – 367 kg (810 lb)

Separation System: Severance/thruster system

Predicted Separation Velocity: Interstage – 5.27 m/s (17.5 ft/s) KV – 5.67 m/s (18.9 ft/s)

Actual Separation Velocity: Interstage – 5.9 m/s (19.8 ft/s), KV – 6.57 m/s (21.9 ft/s)

#### Restraint System Specifications

Configuration: external harness/reaction frame, overhead pivotal suspension tube with integral rip stitch energy absorbers.

Rip stitch energy absorbers: Horizontal – Twelve, 1424-N (320 lbf) energy absorbers,

Vertical – Four, 1424-N energy absorbers incorporated in overhead pivot suspension

Rebound Restraint: pendulum suspension

Free Travel: Horizontal – 0.65 m (2.1 ft), Vertical – 0.08 m (0.25 ft)

Restraint Distance: Horizontal – 0.65 m (2.1 ft), Vertical – 0.15 m (0.5 ft)



DAC 87305

10322.1

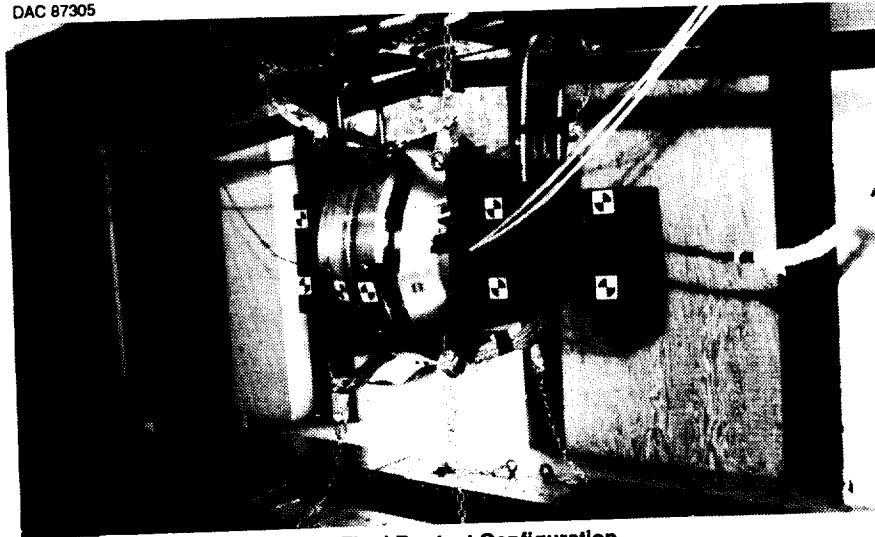

(a) Final Pre-test Configuration

DAC 87323

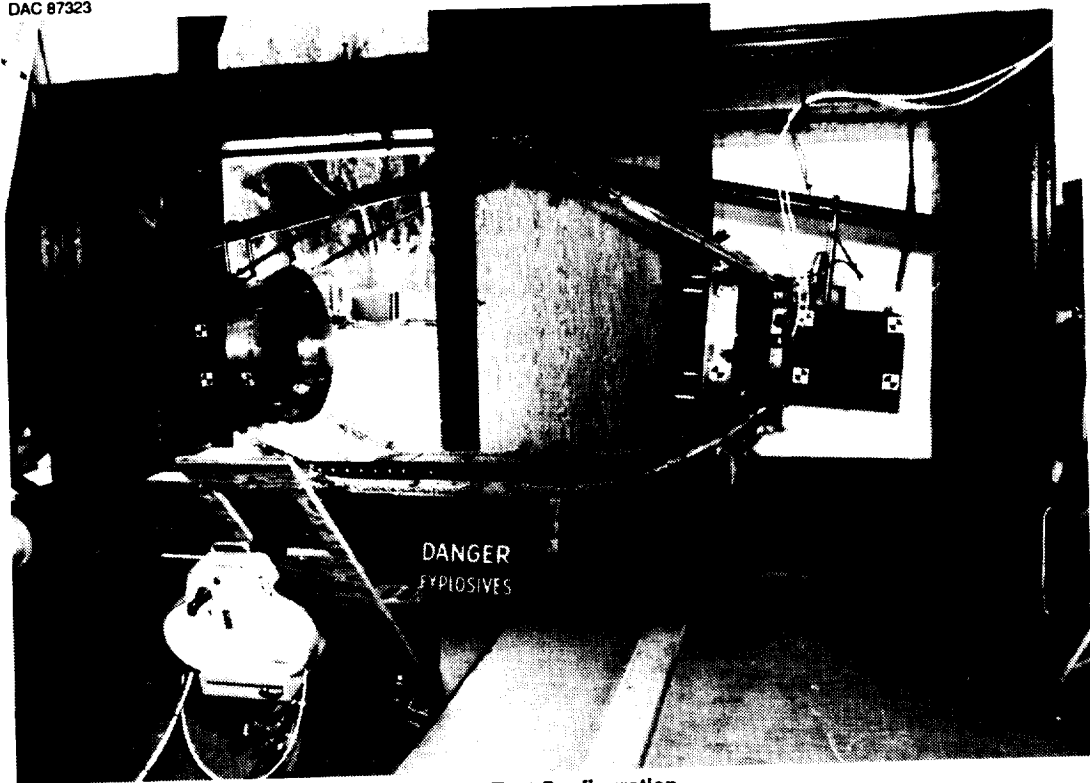

(b) Post-Test Configuration

Figure 10. HEDI ID018A Separation Test

ORIGINAL PAGE  
BLACK AND WHITE PHOTOGRAPH

ORIGINAL PAGE IS  
OF POOR QUALITY

### Test Instrumentation Specifications

High-Speed Cameras: Two Hicam cameras, 1000 fps positioned perpendicular and tangentially to separation plane.

One Hicam, overall view 500 fps

Other: Twenty-eight accelerometers; Eight pressure transducers

### Test Summary

The HEDI 1D018A test successfully demonstrated the separation system performance and acquired necessary pyroshock data. The test restraint system functioned flawlessly and was the laboratory's first implementation of rip-stitch energy absorbers.

## **Delta II Payload Fairing Separation Test, March through November 1988 (Figure 11)**

### Test Article Specifications

Length: 8.6 m (28 ft)

Diameter: 2.5/2.9 m (8 ft/9.5 ft)

Weight: 658 kg (1452 lb)

CG location: 3.6m (12 ft from aft end)

Moment of Inertia: 2283 kg m<sup>2</sup>(1587 slug ft<sup>2</sup>) (pitch axis)

Separation System: Ordnance separated bisector

Predicted Separation Velocity: 5.4 m/s (18 ft/s)

Actual Separation Velocity: 6.3 m/s (21 ft/s)

Predicted Pitch Rate: 0.034 rad/s (2 deg/s)

Actual Pitch Rate: 0.034 rad/s (2 deg/s)

### Restraint System Specifications

Configuration: external capture net, 5 cm polyester webbing. Vertical restraint foam cushion  
Rip stitch energy absorbers: twenty-two (11 per net side) attached to horizontal net members.

■ Eight 667 N (150 Lb<sub>f</sub>) fwd CG

■ Fourteen 445 N (100 Lb<sub>f</sub>) aft CG

Rebound Restraint: four active retracting clutch system six (3 per half) attached to PLF 4 m fwd of CG

Free flight: 0.9 m (3 ft) horizontal

Restraint Distance: 0.6 m (2 ft)

### Test Instrumentation Specifications

High speed cameras: Twelve 1000 fps Hicam cameras positioned along PLF separation plane

Accelerometers : Forty-four

Strain gages: Twelve

### Test Summary

The Delta II PLF Separation shock test program consisted of four tests of the flight and force-margin separation systems. Testing included evaluation of an alternate separation system configuration and simulated separation at 0.7 g due to diminished gravitational effects. The test effort was successfully completed in November 1988 qualifying the Delta II PLF for flight. The separation test capture systems functioned flawlessly enabling four ordnance separations to be performed on the same PLF with no test induced damage.

DAC 85963

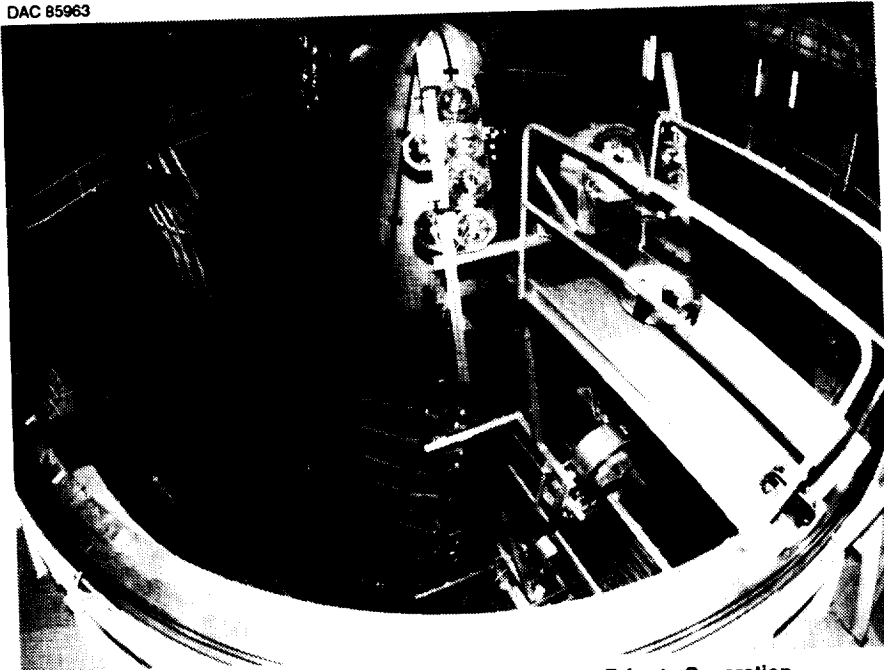

(a) Delta II PLF Installed in 39-Foot Chamber Prior to Separation

DAC 85300



(b) Delta II PLF Post-Test Configuration

Figure 11. Delta II PLF Separation Test

ORIGINAL PAGE  
BLACK AND WHITE PHOTOGRAPH

ORIGINAL PAGE IS  
OF FOUR QUALITY

## Modified Titan Fairing Separation Test, 5 October 1988 (Figure 12)

### Test Article Specifications

Length: 5.25 m (17.5 ft)  
Diameter: 5 m (16.7 ft)  
Weight: 1208 kg (2664 lb)  
Cg location: 2.52 m (8.4 ft) from aft end  
Moment of inertia: 2100 kg m<sup>2</sup>(1459 slug ft<sup>2</sup>) (pitch axis)  
Separation System: ordnance separated trisector  
Predicted Separation Velocity: 5 m/s (16.6 ft/s)  
Actual Separation Velocity: 5.8 m/s (19.4) ft/s Avg.  
Predicted Pitch Rate: 0.14 rad/s (8.3 deg/s) (Forward End Out)  
Actual Pitch Rate: 0.04 rad/s (2.2 deg/s) Avg

### Restraint System Specifications

Configuration: internal reaction radial restraint, overhead compound pendulum vertical restraint  
Rip stitch energy absorbers:  
Horizontal restraint system: total twenty-four attached to each trisector to central reaction frame.

- Six 667 N (150 lb<sub>f</sub>); tearout 0.8 m (2.6 ft) distributed forward of cg for anti-pitch effect
- Eighteen 445 N (100 lb<sub>f</sub>) tearout 0.8 m distributed aft of CG

Vertical restraint: total four per trisector 3337 N (750 lbf) tear out 0.2 m (0.67 ft).  
Rebound Restraint: 12 active retracting clutch systems

### Test Instrumentation Specifications

High Speed Cameras: Sixteen 1000 fps Hicam cameras positioned along PLF separation planes,  
Two video cameras  
Other: Twenty-seven accelerometers, Eighteen strain gages, Three pressure transducers

### Test Summary

The modified Titan PLF separation test posed a tremendous challenge to SSL. The required safe free motion envelope was extremely small relative to the 39-foot Space Chamber's cryogenic shroud walls. In a major departure from traditional fairing restraint methods, the radial capture system was placed inside the fairing and directly attached to the structure with ripper straps. This significantly improved the efficiency of the restraint system over external net based approaches and increased restraint control of the fairing trisector trajectories. The fairing was vertically restrained with an overhead suspension system designed to reduce rebound effects. The test was a complete success despite significant variations from expected pitch rates. The energy margin designed into the radial capture system was expended and the resulting rebound was controlled by the rebound restraint system.

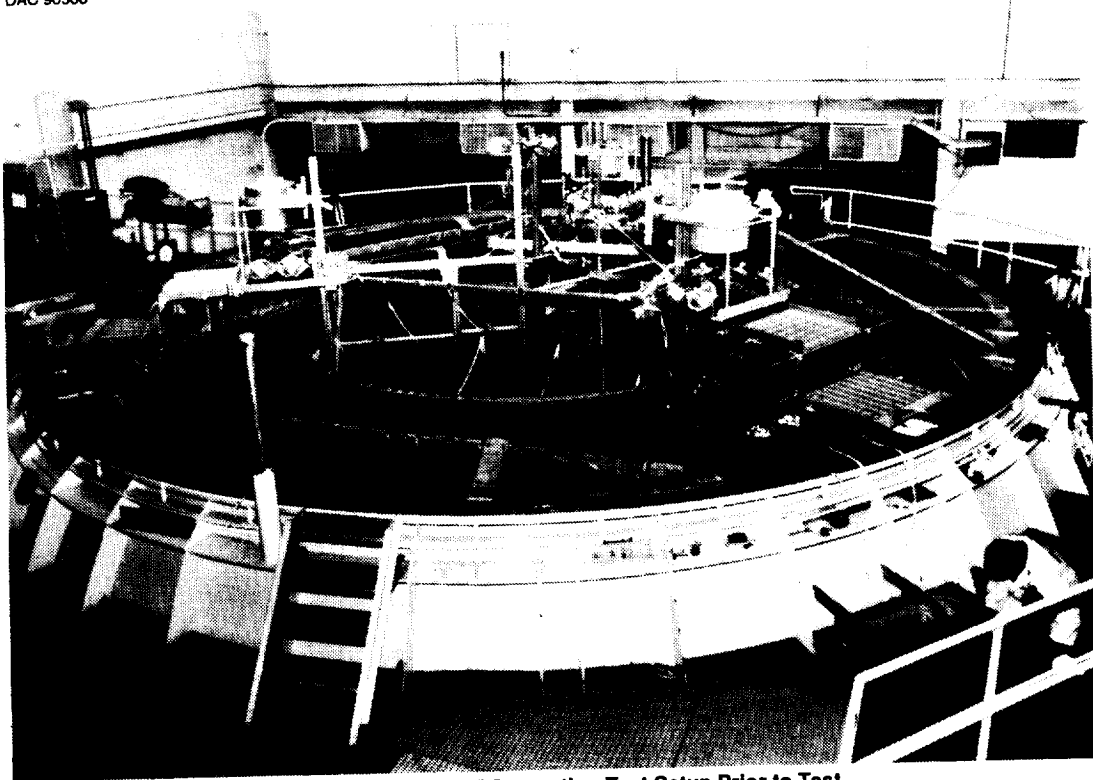

(a) Modified Titan PLF Separation Test Setup Prior to Test

DAC 90639-1

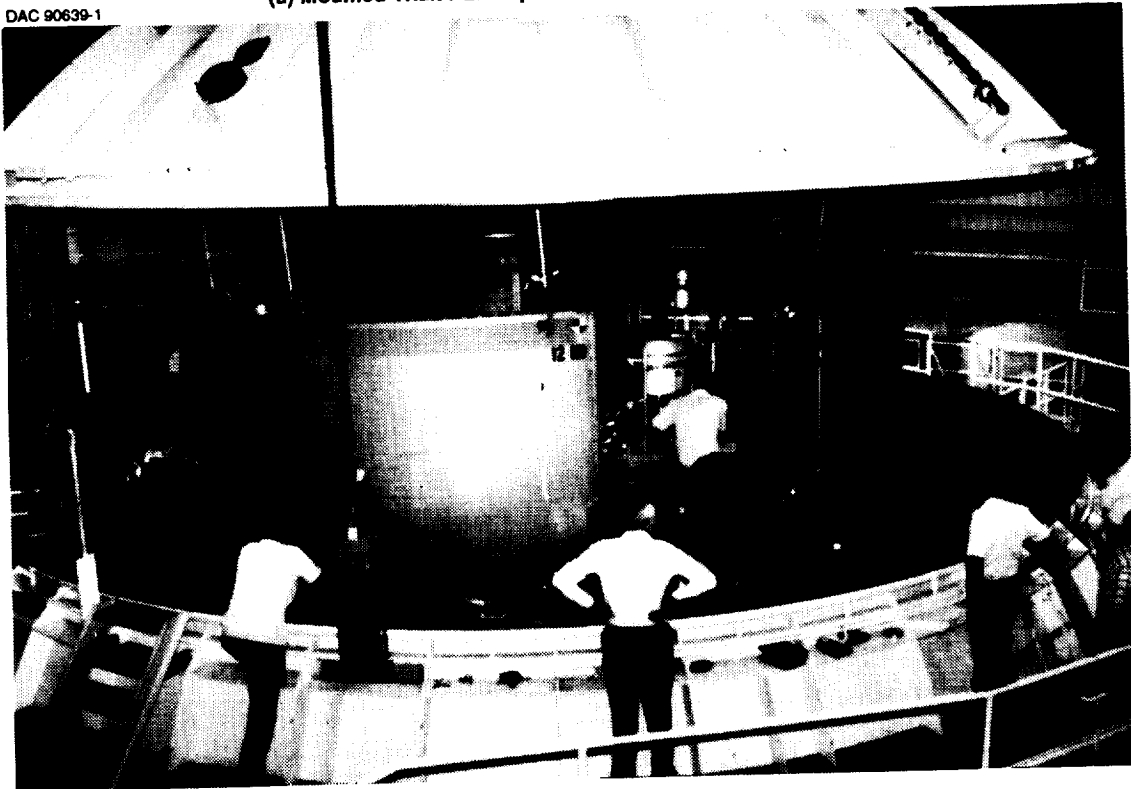

(b) Removal of PLF Following Successful Test

Figure 12. Modified Titan PLF Separation Test

## Delta 10 Foot Payload Fairing Separation Test, 14 November 1989 (Figure 13)

### Test Article Specifications

Length: 3.6 m (12 ft)

Diameter: 2.4 m/3m (8/10 ft)

Weight: 517 kg (1140 lb)

Cg location: 1.44 m (4.8 ft) from aft end

Moment of inertia: 192.8 kg m<sup>2</sup>(134 slug ft<sup>2</sup>) (pitch axis nominal)

Separation System: ordnance separated trisector

Predicted Separation Velocity: 4.5 m/s (15 ft/s)

Actual Separation Velocity: 4 m/s (13.3 ft/s)

Predicted Pitch Rate: 1.19 rad/s (70 deg/s) (Forward End Out)

Actual Pitch Rate: 1.6 rad/s (95.7 deg/s)

DAC 103638

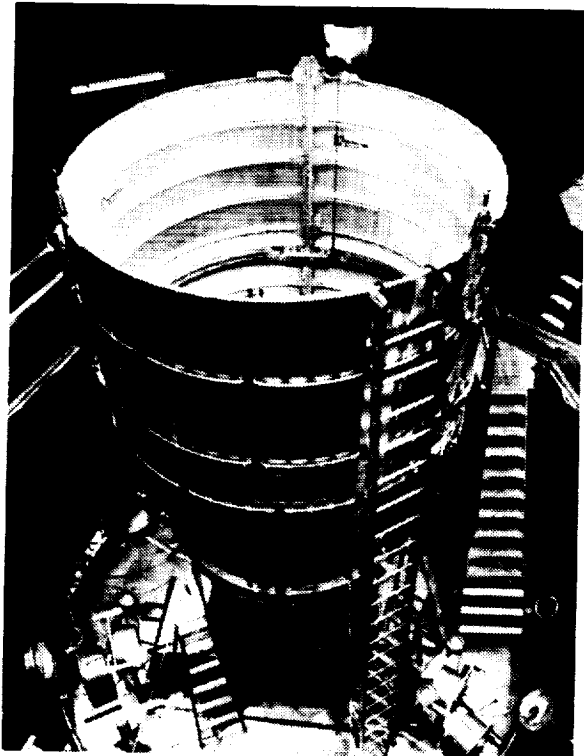

(a) Delta 10-Foot PLF Test Set-Up Prior to Test

DAC 103778-11

103227

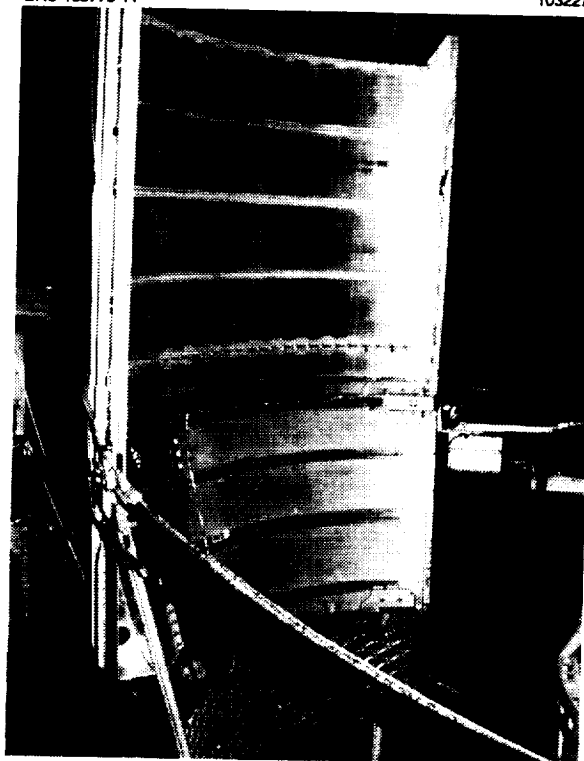

(b) Delta 10-Foot PLF Trisector Captured in Restraint System Following Separation

Figure 13. Delta 10-Foot PLF Separation Test

### Restraint System Specifications

Configuration: Radial restraint: circumferential ripper band (structureless)

Vertical restraint: 2-point overhead suspension with integral ripstitch energy absorbers

Rip stitch energy absorbers:

- Radial restraint system- Five bands with three 245 N (55 lb<sub>f</sub>) ripstitch energy absorbers installed in each band. Bands vertically positioned offset PLF pitch rate.

■ Vertical restraint system- Two 1602 N (360 lb<sub>f</sub>) ripstitch energy absorbers attached to overhead support structure.

Rebound Restraint: Six (2 per trisector) active retracting clutch systems.

Free flight: 0.45 m (1.5 ft) horizontal

Restraint Distance: Radial 1.2 m (4 ft), Vertical 0.54 m (1.8 ft)

#### Test Instrumentation Specifications

High Speed Cameras: Six 400 fps Hicam cameras positioned along PLF separation plane viewing upward at LED self-lighting camera targets; Two video cameras

Other: Thirty-six accelerometers, Twelve strain gages, Six pressure transducers

#### Test Summary

The test successfully qualified the Delta 10-foot diameter PLF. The test approach significantly simplified both PLF dynamic restraint and photo data acquisition. The circumferential ripper band radial restraint system reduced support structure requirements; the vertical restraint system utilized existing handling points eliminating test article structural loading concerns. The test article was successfully captured despite variations from predicted pitch rates which depleted much of the energy margin designed into the restraint system. The photo data acquisition reduced test camera and lighting requirements as well as greatly simplifying photo data reduction. The test served as a proving ground for the test approach utilized for the Titan 86-Foot PLF Separation test.

### **HEDI 1CD02 Interstage Separation Test (Figure 14)**

#### Test Article Specifications

Length: 4 m (13.6 ft)

Diameter: 0.5 m (1.6 ft) nominal

Weight: 661 kg (1458 lb)

Cg location: Sprint/interstage: 1.1 m (3.6 ft) from aft end, KV: 0.84 m (2.8 ft) from aft end

Separation System: Severance/Thruster System

Predicted Separation Velocity: 5.4 m/s (18 ft/s)

Actual Separation Velocity: 5.6 m/s (18.7 ft/s)

#### Restraint System Specifications

Configuration: horizontal restraint external reaction frame, vertical restraint pendulum suspension. Restraint system directly attached to test article with webbing harness.

Rip stitch energy absorbers:

Horizontal: four compound ripper assemblies per separating half. Each ripper assembly consisted of three rippers per assembly. Rip force 1691 N (380 lb<sub>f</sub>) per energy absorber.

Vertical: four ripstitch energy absorbers per separating half. Rip force 1691 N (380 lb<sub>f</sub>) per energy absorber.

Rebound Restraint: four active retracting clutch systems, pendulum suspension

Free travel – horizontal: 0.6 m (2 ft), vertical: 0.15 m (0.5 ft)

Arrest distance – horizontal: 0.4 m (1.3 ft), vertical: 0.19 m (0.63 ft)

#### Test Instrumentation Specifications

High speed cameras: Two Hicam cameras 1000 fps positioned perpendicular to test specimen.

One Hicam camera 1000 fps aligned at nose viewing aft. Two 200 fps overall cameras

Accelerometers: Sixty-six

Pressure Transducers: Four

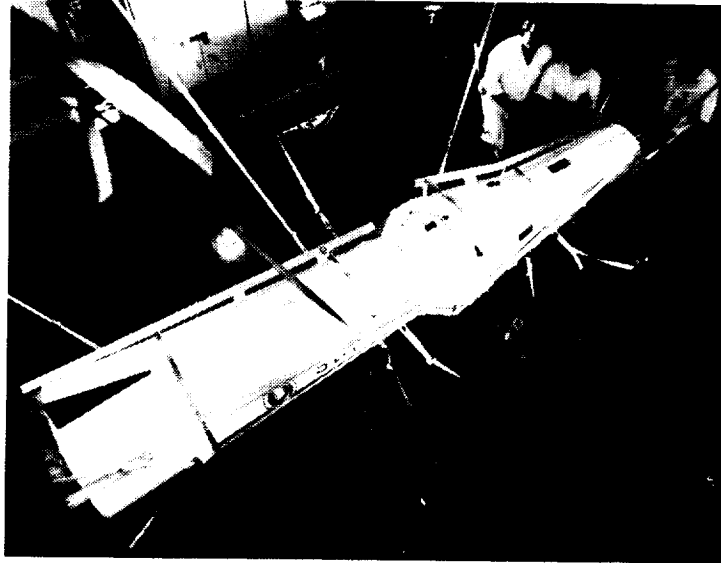

(a) HEDI ICD02 Separation Test Prior to Test

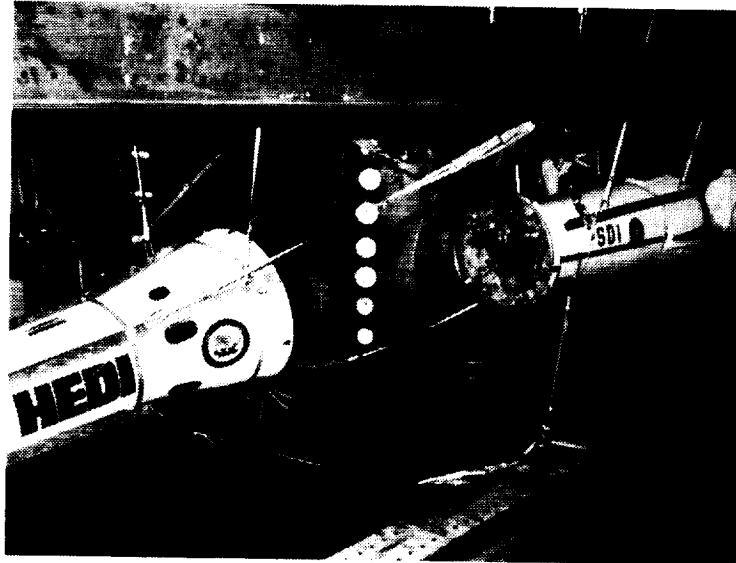

(b) HEDI Test Article Following Successful Separation

Figure 14. HEDI ICD02 Separation Test

### Test Summary

The HEDI ICD02 test repeated the 1D018A test of July 1988 in an actual airframe to increase the fidelity of the separation pyroshock data. The test was performed one month after ATP, demonstrating the advancement of test design techniques. The test was a complete success and gathered useful data.



## PAM-S Separation Tests, December 1989-January 1990 (Figure 15)

### Test Article Specifications

Length: 2 m (6.7 ft)

Diameter: 1.14 m (3.8 ft)

Weight: 1072 kg (2364 lbs)

- Aft Adapter: 907 kg (2000 lb) offloaded with bungee cord and counter weights.
- Motor Support: 79.38 kg (175 lb)

Separation System: Two Phase separation event (Aft adapter and Motor Support). Dual Clampband/Spring Thrusting System

DAC 104477

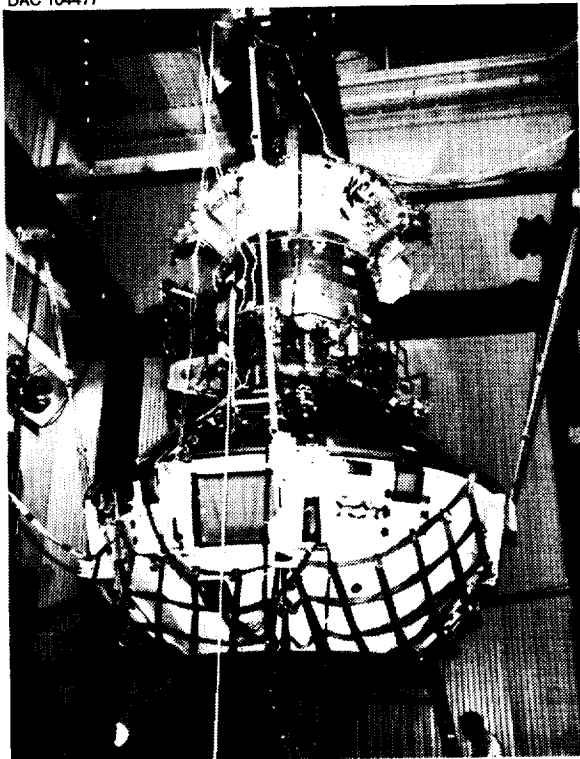

(a) PAM-S Separation Pre-test Configuration

103230.1

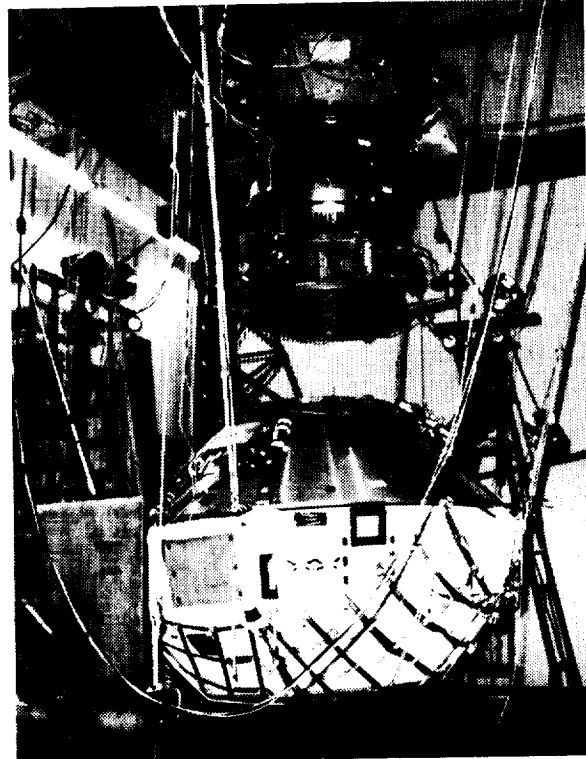

(b) Test Article Following Separation Test

Figure 15. PAM-S Separation Test

### Restraint System Specifications

#### Configuration:

- Aft Adapter Restraint: Four rip stitch energy absorbers directly attached to external frame. Zero G simulation utilizing counterweights and bungee cord
  - Motor Support: Four rip stitch energy absorbers directly attached to external frame.
- Rip stitch energy absorbers: vertical restraint: Eight
- Rebound Restraint: Four clutch systems installed on Aft Adapter counter balance system
- Free travel:
- Aft Adapter: 1.125 m (3.75 ft)
  - Motor Support: 0.15m (0.5 ft)

Arrest Distance:

- Aft Adapter: 0.08 m (0.25 ft)
- Motor Support: 0.1 m (0.35 ft)

Test Instrumentation Specifications

High Speed Cameras: Four Hicam cameras 1000 fps. Two overall video cameras

Accelerometers : Seventy-four

Test Summary

The PAM-S separation test qualified a specialized Payload Assist Module (PAM) design for the Ulysses solar mission. The successful effort consisted of five total separation tests; two separations of the Aft Adapter/IUS, two separation tests of the motor support assembly, and a full system test of the two stage system using the vehicle ordnance sequence system. The restraint system function included a zero-G simulated separation of the Aft Adapter/IUS.

**Titan 86 Foot Payload Fairing Separation Tests, October/November 1990 NASA Sverdrup Plumbrook Station (Figure 16)**

Test Article Specifications

Length: 25.8 m (86 ft)

Diameter: 5 m (16.7 ft)

Weight: 6124 kg (13500 Lb)

CG Location: 9.3 m (31 ft) from aft end (nominal)

Moment of Inertia: 43083 kg m<sup>2</sup> (29940 slug ft<sup>2</sup>) (pitch axis, nominal)

Separation System: ordnance separated trisector

Predicted Separation Velocity: 5.61 m/s (18.7 ft/s) (nominal)

Predicted Pitch Rate: 0.2 rad/s (12 deg/s) (forward end out, nominal)

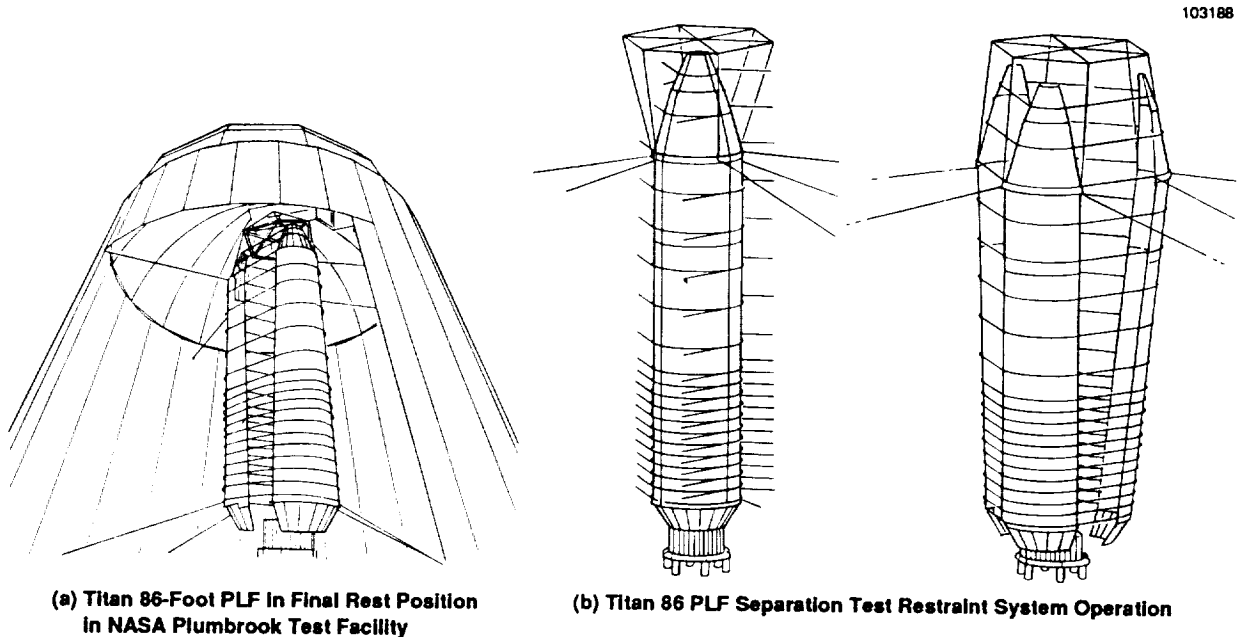

Figure 16. Titan 86-Foot PLF Separation Test

## Restraint System Specifications

### Configuration:

Radial restraint: circumferential ripper band (structureless)

Vertical restraint: 2-point overhead trisector suspension with integral ripstitch energy absorbers.

Trisectors suspended from spreader bar structure attached to chamber polar crane.

### Rip stitch energy absorbers:

Radial restraint system- Twenty bands with three 1157 N (260 lb<sub>f</sub>) ripstitch energy absorbers installed in each band at separation joints. Vertical position of bands determined to offset PLF pitch effects.

Vertical restraint system- Six energy absorber assemblies (two per trisector) attached to overhead support structure. Each assembly consists of Five 4227 N (950 lb<sub>f</sub>) ripstitch energy absorbers.

Rebound Restraint: Twelve (4 per trisector) active retracting clutch system with integral 2448 N (550 lb<sub>f</sub>) rip stitch energy absorbers.

Free flight: 1.5 m (5 ft ) nominal horizontal

Restraint Distance: Radial 0.9 m (3 ft) nominal, Vertical 0.54 m (1.8 ft)

### Test Instrumentation Specifications

High Speed Cameras: six 400 fps cameras positioned along PLF separation plane viewing upward and downward at LED self-lighting camera targets, three 400 fps cameras positioned along PLF trisector center lines; two 400 fps overall cameras; two video cameras.

Other: One-hundred-twenty-one accelerometers; three-hundred-sixty-one strain gages; twenty-four pressure transducers

### Test Summary

The Titan 86 Foot PLF separation test will be the largest fairing separation test attempted to date and reflects significant advances in restraint system design. The test restraint system is essentially structureless, moreover an innovative high speed camera instrumentation approach has greatly reduced the camera quantity, lighting, and related support structure requirements for a test of this magnitude.

## **CONCLUSIONS**

Large scale dynamic tests include a significant element of risk. The application of a deceptively simple and effective restraint system approach has significantly reduced this risk. The high reliability restraint technology has evolved from a systems oriented approach which utilizes industry proven components. The versatile technology has been successfully applied to a wide variety of test applications.



**SESSION VI**

**MATERIAL DEGRADATION IN ORBIT**

