

04
N91-20517

Finite Element Solution of Transient Fluid-Structure Interaction Problems

Gordon C. Everstine, Raymond S. Cheng, and Stephen A. Hambric

Computational Mechanics Division (128)
David Taylor Research Center
Bethesda, Maryland 20084

ABSTRACT

A finite element approach using NASTRAN is developed for solving time-dependent fluid-structure interaction problems, with emphasis on the transient scattering of acoustic waves from submerged elastic structures. Finite elements are used for modeling both structure and fluid domains to facilitate the graphical display of the wave motion through both media. For the fluid, the use of velocity potential as the fundamental unknown results in a symmetric matrix equation. The approach is illustrated for the problem of transient scattering from a submerged elastic spherical shell subjected to an incident tone burst. The use of an analogy between the equations of elasticity and the wave equation of acoustics, a necessary ingredient to the procedure, is summarized.

INTRODUCTION

Computational structural acoustics is concerned with the prediction of the acoustic pressure field radiated or scattered by submerged structures subjected to either mechanical or external (fluid) excitation. When the excitation is time-harmonic, the most common numerical approach for solving the interaction problem is to couple a finite element model of the structure with a boundary element model of the surrounding fluid (Ref. 1-8). Other fluid modeling approaches have included finite element (Ref. 9-20), combined finite element/analytical (Ref. 21-23), and T-matrix (Ref. 24-26).

For time domain (transient) analysis, there are several computational approaches which can be used:

- the transformation of frequency domain results to the time domain using the Fourier transform
- the use of a fluid loading approximation such as the doubly asymptotic approximation (DAA) (Ref. 27)
- the time domain boundary element approach, which models the fluid with the retarded potential integral equation (Ref. 28-31)
- the fluid finite element approach, which models the exterior fluid domain with finite elements truncated at a finite distance from the structure and terminated with an approximate radiation boundary condition to absorb outgoing waves (Ref. 9-20)

To our knowledge, the retarded potential integral equation has been used only for special geometries (e.g., axisymmetry) because of the method's relatively high computational cost. The DAA approach, which has been used successfully in underwater shock analysis (Ref. 32-34), may not be adequate for transient acoustics, where the interest is in the response in the fluid as well as in the structure. The principal computational trade-off between the fluid finite element approach and the other three approaches is that the finite element approach yields large, banded matrices, whereas the other three

approaches (which depend on boundary element calculations) yield smaller, densely-populated matrices. This trade-off often favors the finite element approach for long, slender structures like ships which are "naturally banded." In addition, of the four approaches listed, only the fluid finite element approach has directly available an explicit fluid mesh which can be used for graphical display of the wave motion through the fluid. Since a significant part of our interest involves the display of wave propagation through both structure and fluid, we therefore formulate the transient acoustics problem using the fluid finite element approach. The principal drawbacks to a fluid finite element approach are the need for an approximate radiation boundary condition at the outer fluid boundary, the requirements on mesh size and extent (sometimes leading to frequency-dependent fluid meshes (Ref. 17)), and the difficulty of generating the fluid mesh.

Dynamics problems involving the interaction between an elastic structure and an acoustic fluid have been formulated for finite element solution using pressure (Ref. 9,10), fluid particle displacement (Ref. 11-13,15,17), displacement potential (Ref. 16), and velocity potential (Ref. 18,19) as the fundamental unknown in the fluid region. In three dimensions, the pressure and displacement formulations result in, respectively, one and three degrees of freedom per finite element mesh point. Thus the pressure approach has the advantage of fewer unknowns and a smaller overall matrix profile or bandwidth if the grid points are properly sequenced. On the other hand, the displacement approach results in symmetric coefficient matrices (in contrast to the pressure formulation, for which the matrices are nonsymmetric) and a fluid-structure interface condition which is easier to implement with general purpose finite element computer programs. However, the displacement approach also suffers from the presence of spurious resonances (Ref. 15), a situation which can be bothersome in time-harmonic problems, either forced or unforced. The principal disadvantage of the pressure formulation, nonsymmetric coefficient matrices, can be removed merely by reformulating the pressure solution approach so that a velocity potential rather than pressure is used as the fundamental unknown in the fluid region (Ref. 18). For some situations, particularly time-harmonic problems involving damped systems and time-dependent problems, significant computational advantages result.

The principal goal of this paper is to develop in detail the symmetric velocity potential formulation for application to the specific problem of transient acoustic scattering from submerged elastic structures. Previously (Ref. 18), the symmetric potential formulation was described only in general terms for a wide class of fluid-structure interaction problems with no details concerning specific types of applications such as vibrations, shock response, or acoustic scattering.

From an engineering point of view, it is convenient to be able to make use of existing general purpose finite element codes such as NASTRAN, because of their wide availability, versatility, reliability, consultative support, and abundance of pre- and postprocessors. Thus the next section summarizes an analogy between the equations of elasticity and the wave equation of acoustics. Such an analogy allows the coupled structural acoustic problem to be solved with standard finite element codes.

STRUCTURAL-ACOUSTIC ANALOGY

Since we wish to solve the coupled structural acoustic problem using standard finite element codes, we summarize here the application of such codes to the wave equation of acoustics (Ref. 35,36),

$$\nabla^2 p = \ddot{p}/c^2, \tag{1}$$

where ∇^2 is the Laplacian operator, p is the dynamic fluid pressure, c is the wave speed, and dots denote partial differentiation with respect to time.

On the other hand, the x-component of the Navier equations of elasticity, which are the equations solved by structural analysis computer programs, is

$$\frac{\lambda+2G}{G}u_{,xx} + u_{,yy} + u_{,zz} + \frac{\lambda+G}{G}(v_{,xy} + w_{,xz}) + \frac{1}{G}f_x = \frac{\rho}{G}\ddot{u}, \quad (2)$$

where u , v , and w are the Cartesian components of displacement, λ is a Lamé elastic constant, G is the shear modulus, f_x is the x -component of body force per unit volume (e.g., gravity), ρ is the mass density, and commas denote partial differentiation.

A comparison of Eqs. 1 and 2 indicates that elastic finite elements can be used to model scalar pressure fields if we let u , the x -component of displacement, represent p , set $v = w = 0$ everywhere, $f_x = 0$, and $\lambda = -G$. For three-dimensional analysis, the engineering constants consistent with this last requirement are (Ref. 36)

$$E_e = 10^{20}G_e, \quad \rho_e = G_e/c^2, \quad (3)$$

where the element shear modulus G_e can be selected arbitrarily. The subscript "e" has been added to these constants to emphasize that they are merely numbers assigned to the elements.

A variety of boundary conditions may also be imposed. At a pressure-release boundary, $p = 0$ is enforced explicitly like other displacement boundary conditions. For gradient conditions, the pressure gradient $\partial p/\partial n$ is enforced at a boundary point by applying a "force" to the unconstrained DOF at that point equal to $G_e A \partial p/\partial n$, where A is the area assigned to the point and n is the outward normal from the fluid region (Ref. 36). For example, the plane wave absorbing boundary condition

$$\frac{\partial p}{\partial n} = -\frac{\dot{p}}{c} \quad (4)$$

is enforced by applying to each point on the outer fluid boundary a "force" given by $-(G_e A/c)\dot{p}$. Since this "force" is proportional to the first time derivative of the fundamental solution variable p , this boundary condition is imposed in the analogy by attaching to the fluid DOF a "dashpot" of constant $G_e A/c$. The Neumann condition $\partial p/\partial n = 0$ is the natural boundary condition under this analogy. The next higher order local radiation boundary condition, the curved wave absorbing boundary condition (Ref. 20,37)

$$\frac{\partial p}{\partial n} = -\frac{\dot{p}}{c} - \frac{p}{r}, \quad (5)$$

where r is the radius of the boundary, is enforced under the analogy by attaching in parallel both a "dashpot" and a "spring" between each boundary point and ground.

At a fluid-structure interface (an accelerating boundary), momentum and continuity considerations require that

$$\frac{\partial p}{\partial n} = -\rho \ddot{u}_n, \quad (6)$$

where n is the normal at the interface, ρ is the mass density of the fluid, and \ddot{u}_n is the normal component of fluid particle acceleration. Under the analogy, this condition is enforced by applying to the fluid DOF at a fluid-structure interface a "force" given by $-(G_e \rho A)\ddot{u}_n$.

To summarize, the wave equation, Eq. 1, can be solved with elastic finite elements if the three-dimensional region is modeled with 3-D solid finite elements having material properties given by Eq. 3, and only one of the three Cartesian components of displacement is retained to represent the scalar variable p . In Cartesian coordinates, any of the three components can be used. The solution of axisymmetric problems in cylindrical coordinates follows the same approach except that the z -component of displacement is the only one which can be used to represent p (Ref. 36).

SCATTERING FROM ELASTIC STRUCTURES

In the scattering problem, a submerged elastic body is subjected to a plane wave incident loading, as shown in Fig. 1. For the time-harmonic case, the excitation has a single circular frequency ω . For the time-dependent (transient) case of interest here, the prescribed pressure loading is an arbitrary function of time. Without loss of generality, we can assume that the incident wave propagates in the negative z direction. The speed of such propagation is c , the speed of sound in the fluid.

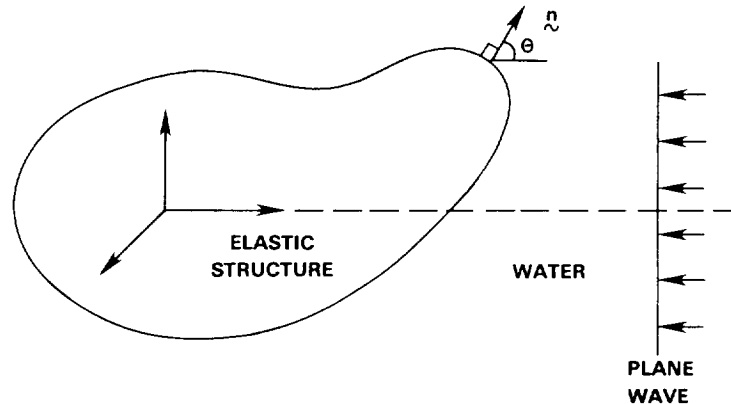

Fig. 1. The scattering problem.

Within the fluid region, the total pressure p satisfies the wave equation, Eq. 1. Since the incident free-field pressure p_i is known, it is convenient to decompose the total pressure p into the sum of incident and scattered pressures

$$p = p_i + p_s, \tag{7}$$

each of which satisfies the wave equation. (By definition, the incident free-field pressure is that pressure which would occur in the fluid in the absence of any scatterer.)

We now formulate the problem for finite element solution. Consider an arbitrary, submerged, three-dimensional elastic structure subjected to either internal time-dependent loads or an external time-dependent incident pressure. If the structure is modeled with finite elements, the resulting matrix equation of motion for the structural degrees of freedom (DOF) is

$$M\ddot{u} + B\dot{u} + Ku = F - GA_p, \tag{8}$$

where M , B , and K are the structural mass, viscous damping, and stiffness matrices (dimension $s \times s$), respectively, u is the displacement vector for all structural DOF (wet and dry) in terms of the coordinate systems selected by the user ($s \times r$), F is the vector of applied mechanical forces applied to the structure ($s \times r$), G is the rectangular transformation matrix of direction cosines to transform a vector of outward normal forces at the wet points to a vector of forces at all points in the coordinate systems selected by the user ($s \times f$), A is the diagonal area matrix for the wet surface ($f \times f$), p is the vector of total fluid pressures (incident + scattered) applied at the wet grid points ($f \times r$), and dots denote differentiation with respect to time. The pressure p is assumed positive in compression. In the above dimensions, s denotes the total number of independent structural DOF (wet and dry), f denotes the number of fluid DOF (the number of wet points), and r denotes the number of load cases. If first order finite elements are used for the surface discretization, surface areas, normals, and the transformation matrix G can be obtained from the calculation of the load vector resulting from an outwardly directed static unit pressure load on the structure's wet surface. The matrix

product GA can then be interpreted as the matrix which converts a vector of negative fluid pressures to structural loads in the global coordinate system. The last two equations can be combined to yield

$$M\ddot{u} + B\dot{u} + Ku + GA p_s = F - GA p_i. \quad (9)$$

A finite element model of the fluid region (with scattered pressure p_s as the unknown) results in a matrix equation of the form

$$Q\ddot{p}_s + C\dot{p}_s + Hp_s = F^{(p)}, \quad (10)$$

where p_s is the vector of scattered fluid pressures at the grid points of the fluid region, Q and H are the fluid "inertia" and "stiffness" matrices (analogous to M and K for structures), C is the "damping" matrix arising from the radiation boundary condition (Eq. 4), and $F^{(p)}$ is the "loading" applied to fluid DOF due to the fluid-structure interface condition, Eq. 6. Using the analogy described in the preceding section, structural finite elements can be used to model both structural and fluid regions. Material constants assigned to the elastic elements used to model the fluid are specified according to Eq. 3. In three dimensions, elastic solid elements are used (e.g., isoparametric bricks for general 3-D analysis or solids of revolution for axisymmetric analysis).

At the fluid-structure interface, Eqs. 6 and 7 can be combined to yield

$$\frac{\partial p_s}{\partial n} = \rho(\ddot{u}_{ni} - \ddot{u}_n), \quad (11)$$

where n is the outward unit normal, and \ddot{u}_{ni} and \ddot{u}_n are, respectively, the incident and total outward normal components of fluid particle acceleration at the interface. Thus, from the analogy, we impose the fluid-structure interface condition by applying a "load" to each interface fluid point given by

$$F^{(p)} = -\rho G_e A (\ddot{u}_{ni} - \ddot{u}_n), \quad (12)$$

where the first minus sign is introduced since, in the coupled problem, we choose n as the outward normal from the structure into the fluid, making n an inward normal for the fluid region. The normal displacements u_n are related to the total displacements u by the same rectangular transformation matrix G used above:

$$u_n = G^T u, \quad (13)$$

where the superscript T denotes the matrix transpose. Eqs. 10, 12, and 13 can be combined to yield

$$Q\ddot{p}_s + C\dot{p}_s + Hp_s - \rho G_e (GA)^T \ddot{u} = -\rho G_e A \ddot{u}_{ni}. \quad (14)$$

Since the fluid-structure coupling terms in Eqs. 9 and 14 are nonsymmetric, we symmetrize the problem (Ref. 18) by using a new fluid unknown q such that

$$q = \int_0^t p_s dt, \quad \dot{q} = p_s. \quad (15)$$

If Eq. 14 is integrated in time, and the fluid element "shear modulus" G_e is chosen as

$$G_e = -1/\rho, \quad (16)$$

the overall matrix system describing the coupled problem can be written as

$$\begin{bmatrix} M & 0 \\ 0 & Q \end{bmatrix} \begin{Bmatrix} \ddot{u} \\ \dot{q} \end{Bmatrix} + \begin{bmatrix} B & (GA) \\ (GA)^T & C \end{bmatrix} \begin{Bmatrix} \dot{u} \\ q \end{Bmatrix} + \begin{bmatrix} K & 0 \\ 0 & H \end{bmatrix} \begin{Bmatrix} u \\ q \end{Bmatrix} = \begin{Bmatrix} F - (GA)p_i \\ A v_{ni} \end{Bmatrix}, \quad (17)$$

where v_{ni} ($=\dot{u}_{ni}$) is the outward normal component of incident fluid particle velocity.

The new variable q is, except for a multiplicative constant, the velocity potential ϕ , since

$$p = -\rho\dot{\phi}. \quad (18)$$

Eq. 17 could also be recast in terms of ϕ rather than q as the fundamental fluid unknown, but no particular advantage would result. In fact, the use of q rather than ϕ has the practical advantage that the fluid pressure can be recovered directly from the finite element program as the time derivative (velocity) of the unknown q .

To summarize, both structural and fluid regions are modeled with finite elements. For the fluid region, the material constants assigned to the finite elements are

$$E_e = -10^{20}/\rho, \quad G_e = -1/\rho, \quad \nu_e = \text{unspecified}, \quad \rho_e = -1/(\rho c^2), \quad (19)$$

where E_e , G_e , ν_e , and ρ_e are the Young's modulus, shear modulus, Poisson's ratio, and mass density, respectively, assigned to the fluid finite elements. The properties ρ and c above are the actual density and sound speed for the fluid medium. The radiation boundary condition used is the plane wave approximation, Eq. 4, which appears to be adequate if the outer fluid boundary is sufficiently far from the structure (Ref. 17). With this boundary condition, matrix C in Eq. 17 arises from dashpots applied at the outer fluid boundary with damping constant $-A/(\rho c)$ at each grid point to which the area A has been assigned. At the fluid-structure interface, matrix GA is entered using the areas (or areal direction cosines) assigned to each wet degree of freedom. (Recall that GA can be interpreted as the matrix which converts a vector of negative fluid pressures to structural loads in the global coordinate system.)

The right-hand side of Eq. 17 can be simplified further since, for plane waves propagating in the negative z direction at speed c , the incident free-field pressure and incident fluid particle velocity in the z direction are related by (Ref. 38)

$$p_i = -\rho c v_{zi}. \quad (20)$$

Then, like in Fig. 1, if we define θ as the angle between the normal n and the positive z axis,

$$v_{ni} = v_{zi} \cos \theta = -p_i \cos \theta / (\rho c). \quad (21)$$

For plane waves, the z component of the free-field fluid particle velocity v_{zi} is the same at all points in space except for a time delay, which depends only on the z coordinate of the points.

Thus, Eq. 17 can alternatively be written

$$\begin{bmatrix} \mathbf{M} & \mathbf{0} \\ \mathbf{0} & \mathbf{Q} \end{bmatrix} \begin{Bmatrix} \ddot{\mathbf{u}} \\ \ddot{\mathbf{q}} \end{Bmatrix} + \begin{bmatrix} \mathbf{B} & (\mathbf{GA}) \\ (\mathbf{GA})^T & \mathbf{C} \end{bmatrix} \begin{Bmatrix} \dot{\mathbf{u}} \\ \dot{\mathbf{q}} \end{Bmatrix} + \begin{bmatrix} \mathbf{K} & \mathbf{0} \\ \mathbf{0} & \mathbf{H} \end{bmatrix} \begin{Bmatrix} \mathbf{u} \\ \mathbf{q} \end{Bmatrix} = \begin{Bmatrix} \mathbf{F} - (\mathbf{GA})p_i \\ -\mathbf{A}p_i \cos \theta / (\rho c) \end{Bmatrix}. \quad (22)$$

This is the form of the equations which we will use to solve the transient scattering problem. The right-hand side, which has nonzero contributions for both structure and fluid interface points, depends only on the incident free-field pressure at the fluid-structure interface. For scattering problems, the mechanical load \mathbf{F} is zero. For radiation problems, \mathbf{F} is nonzero, and the incident pressure p_i vanishes.

We note that the structural and fluid unknowns are not sequenced as perhaps implied by the partitioned form of Eq. 22. The coupling matrix GA is quite sparse and has nonzeros only for matrix rows associated with the structural DOF at the fluid-structure interface and columns associated with the coincident fluid points. Thus, the grid points should be sequenced for minimum matrix bandwidth or profile as if the structural and fluid meshes comprised a single large mesh. As a result, the structural and fluid grid points will, in general, be interspersed in their numbering, and the system matrices will be sparse and banded.

EXAMPLE: SCATTERING FROM A SUBMERGED SPHERICAL SHELL

The validation of the procedure described above was made by comparing the finite element prediction of the time history of the structural response of a spherical shell subjected to a step incident pressure loading with the series solution (Ref. 28,39). These results will not be presented here. Instead, we will illustrate the approach by calculating the transient response of a submerged, thin-walled, evacuated spherical shell subjected to a brief tone burst, as illustrated in Fig. 2. For convenience, we nondimensionalize lengths to the shell mean radius a , velocities to the fluid sound speed c , and pressures to the fluid bulk modulus ρc^2 . Thus, nondimensional time becomes ct/a . The particular problem solved was a 2% thick steel shell immersed in water. Hence, in nondimensional units, the shell properties are thickness = 0.02, Young's modulus = 96.9, Poisson's ratio = 0.3, and density = 7.79.

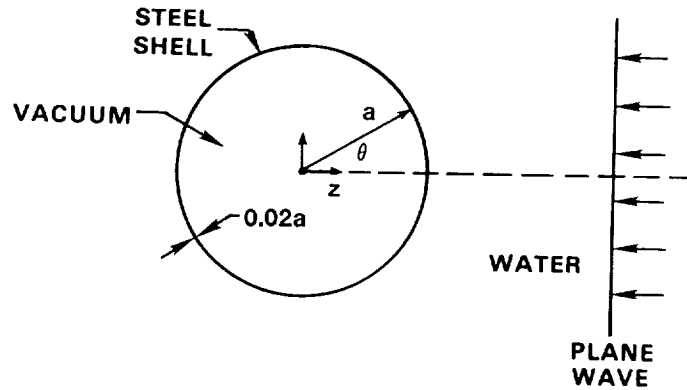

Fig. 2. Scattering from a submerged spherical shell.

The incident free-field pressure $p_i(z, t)$ is given by

$$p_i(x, y, z, t) = \hat{p}_i\left(t + \frac{z-a}{c}\right), \quad (23)$$

where (Fig. 3)

$$\hat{p}_i(t) = \begin{cases} p_o (1 - \cos \omega t)/2, & 0 \leq \omega t \leq \pi \\ -p_o \cos \omega t, & \pi \leq \omega t \leq (n-1)\pi \\ -p_o (1 + \cos \omega t)/2, & (n-1)\pi \leq \omega t \leq n\pi \\ 0, & \text{otherwise.} \end{cases} \quad (n \text{ odd}) \quad (24)$$

For this problem, $p_o=1$, $n=5$, and $\omega a/c=\pi$.

Since this problem is axisymmetric, it was modeled for finite element solution using NASTRAN's conical shell elements (CONEAX) for the shell and triangular ring elements (TRIAAX) for the fluid. A typical fluid mesh is shown in Fig. 4, where the shell is coincident with the inner semi-circle of fluid grid points. The actual mesh used to generate the results which follow had the outer fluid boundary located at 8 radii, used 24 elements along the inner radius between the poles and 56 elements in the radial direction, resulting in a total of 25 structural grid points, 6213 fluid grid points, 24 CONEAX elements, 12096 TRIAAX elements, and 6288 independent degrees of freedom. For the direct time integration, 800 nondimensional time steps of size 0.025 were used.

Results are presented for both velocity response of the shell and scattered pressure response in the fluid. Fig. 5 shows plots of time histories of shell velocity in the z direction for the point first

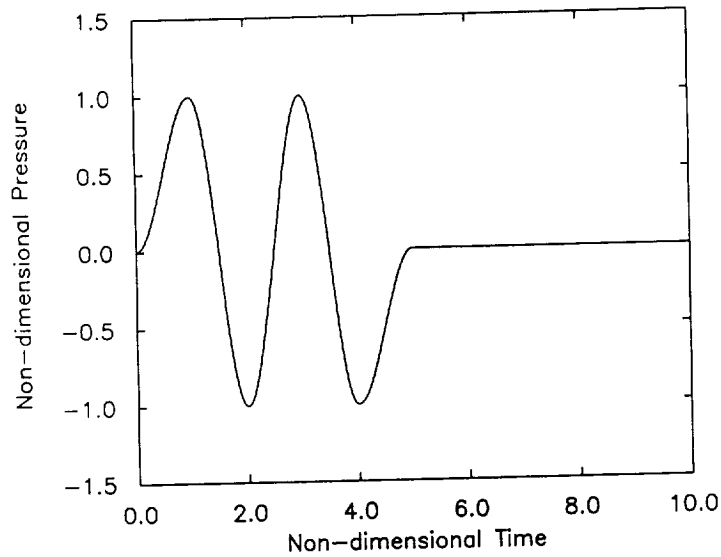

Fig. 3. The incident pressure $\hat{p}_i(t)$ (Eq. 24).

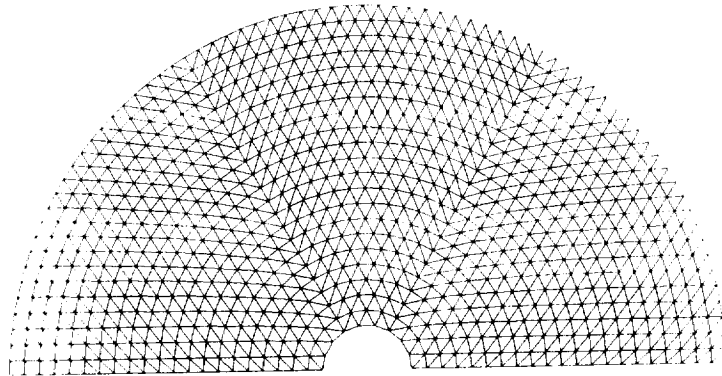

Fig. 4. Typical finite element mesh.

impacted by the pressure wave ($\theta=0$) and the back side pole ($\theta=180$ degrees). We observe from the figure a significant oscillation in the back side of the shell. Back-scattered pressure time histories are displayed in Fig. 6 at 3 and 5 radii from the origin. As expected, the scattered pressure at fluid points is zero until the wave has had time to travel (at unit nondimensional speed) from the spherical shell. Since the two points displayed are located 2 and 4 radii from the shell, the nondimensional time delays for the scattered pressure wave to arrive are 2 and 4, respectively.

DISCUSSION

A practical procedure has been presented, using standard capabilities in NASTRAN, for computing the solution of general time-dependent structural acoustics problems. Although illustrated for the simple geometry of spherical shell scattering, there is no restriction in the approach to particular geometries, so that any structure which can be modeled with NASTRAN can be handled.

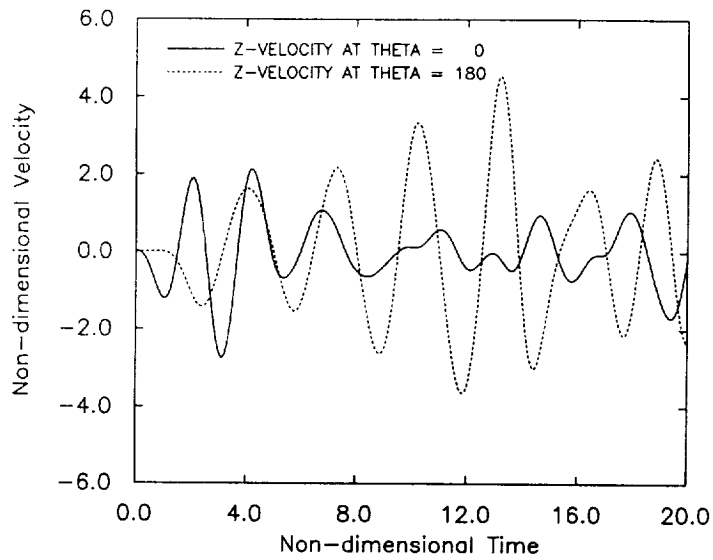

Fig. 5. Time histories of shell velocity in the z direction.

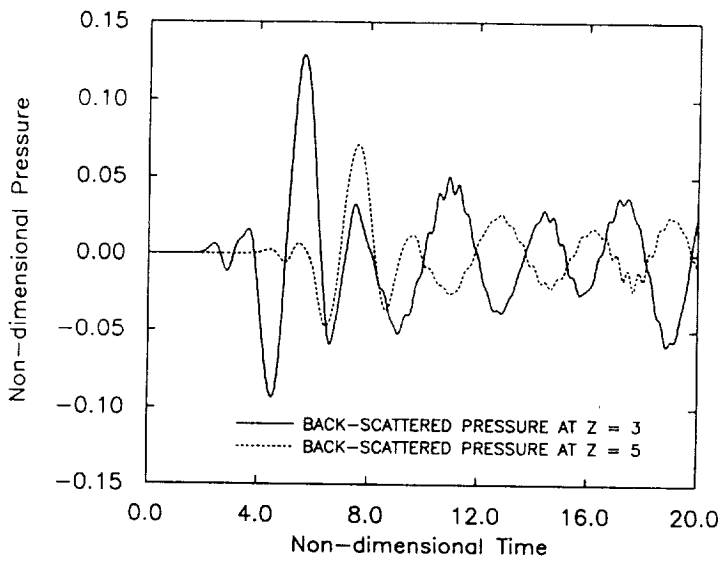

Fig. 6. Time histories of scattered pressure.

One of the major benefits of analyzing transient fluid-structure interaction with a general-purpose code like NASTRAN is the ability to integrate the acoustic analysis of a structure with other dynamic and stability analyses. Thus the same finite element model can often be used for modal analysis, frequency and transient response analysis, linear shock analysis, and underwater acoustic analysis. In addition, many of the pre- and postprocessors developed for use with NASTRAN become available for acoustics as well.

REFERENCES

1. L.H. Chen and D.G. Schweikert, "Sound Radiation from an Arbitrary Body," **J. Acoust. Soc. Amer.**, Vol. 35, No. 10, pp. 1626-1632 (1963).
2. D.T. Wilton, "Acoustic Radiation and Scattering from Elastic Structures," **Int. J. Num. Meth. in Engrg.**, Vol. 13, pp. 123-138 (1978).
3. J.S. Patel, "Radiation and Scattering from an Arbitrary Elastic Structure Using Consistent Fluid Structure Formulation," **Comput. Struct.**, Vol. 9, pp. 287-291 (1978).
4. I.C. Mathews, "Numerical Techniques for Three-Dimensional Steady-State Fluid-Structure Interaction," **J. Acoust. Soc. Amer.**, Vol. 79, pp. 1317-1325 (1986).
5. G.C. Everstine, F.M. Henderson, E.A. Schroeder, and R.R. Lipman, "A General Low Frequency Acoustic Radiation Capability for NASTRAN," **Fourteenth NASTRAN Users' Colloquium**, NASA CP-2419, National Aeronautics and Space Administration, Washington, DC, pp. 293-310 (1986).
6. G.C. Everstine, F.M. Henderson, and L.S. Schuetz, "Coupled NASTRAN/Boundary Element Formulation for Acoustic Scattering," **Fifteenth NASTRAN Users' Colloquium**, NASA CP-2481, National Aeronautics and Space Administration, Washington, DC, pp. 250-265 (1987).
7. A.F. Seybert, T.W. Wu, and X.F. Wu, "Radiation and Scattering of Acoustic Waves from Elastic Solids and Shells Using the Boundary Element Method," **J. Acoust. Soc. Amer.**, Vol. 84, pp. 1906-1912 (1988).
8. G.C. Everstine and F.M. Henderson, "Coupled Finite Element/Boundary Element Approach for Fluid-Structure Interaction," **J. Acoust. Soc. Amer.**, Vol. 87, No. 5, pp. 1938-1947 (1990).
9. O.C. Zienkiewicz and R.E. Newton, "Coupled Vibrations of a Structure Submerged in a Compressible Fluid," **Proc. Internat. Symp. on Finite Element Techniques**, Stuttgart, pp. 359-379 (1969).
10. A. Craggs, "The Transient Response of a Coupled Plate-Acoustic System Using Plate and Acoustic Finite Elements," **J. Sound and Vibration**, Vol. 15, No. 4, pp. 509-528 (1971).
11. A.J. Kalinowski, "Fluid Structure Interaction," **Shock and Vibration Computer Programs: Reviews and Summaries**, SVM-10, ed. by W. Pilkey and B. Pilkey, The Shock and Vibration Information Center, Naval Research Laboratory, Washington, DC, pp. 405-452 (1975).
12. L. Kiefling and G.C. Feng, "Fluid-Structure Finite Element Vibrational Analysis," **AIAA J.**, Vol. 14, No. 2, pp. 199-203 (1976).
13. A.J. Kalinowski, "Transmission of Shock Waves into Submerged Fluid Filled Vessels," **Fluid Structure Interaction Phenomena in Pressure Vessel and Piping Systems**, PVP-PB-026, ed. by M.K. Au-Yang and S.J. Brown, Jr., The American Society of Mechanical Engineers, New York, pp. 83-105 (1977).
14. O.C. Zienkiewicz and P. Bettess, "Fluid-Structure Dynamic Interaction and Wave Forces: An Introduction to Numerical Treatment," **Int. J. Num. Meth. in Engrg.**, Vol. 13, No. 1, pp. 1-6 (1978).
15. M.A. Hamdi and Y. Ousset, "A Displacement Method for the Analysis of Vibrations of Coupled Fluid-Structure Systems," **Int. J. Num. Meth. in Engrg.**, Vol. 13, No. 1, pp. 139-150 (1978).
16. R.E. Newton, "Finite Element Study of Shock Induced Cavitation," Preprint 80-110, American Society of Civil Engineers, New York (1980).

17. A.J. Kalinowski and C.W. Nebelung, "Media-Structure Interaction Computations Employing Frequency-Dependent Mesh Size with the Finite Element Method," **Shock Vib. Bull.**, Vol 51, No. 1, pp. 173-193 (1981).
18. G.C. Everstine, "A Symmetric Potential Formulation for Fluid-Structure Interaction," **J. Sound and Vibration**, Vol. 79, pp. 157-160 (1981).
19. G.C. Everstine, "Structural-Acoustic Finite Element Analysis, with Application to Scattering," in **Proc. 6th Invitational Symposium on the Unification of Finite Elements, Finite Differences, and Calculus of Variations**, edited by H. Kardestuncer, Univ. of Connecticut, Storrs, Connecticut, pp. 101-122 (1982).
20. P.M. Pinsky and N.N. Abboud, "Transient Finite Element Analysis of the Exterior Structural Acoustics Problem," **Numerical Techniques in Acoustic Radiation**, edited by R.J. Bernhard and R.F. Keltie, NCA-Vol. 6, American Society of Mechanical Engineers, New York, pp. 35-47 (1989).
21. J.T. Hunt, M.R. Knittel, and D. Barach, "Finite Element Approach to Acoustic Radiation from Elastic Structures," **J. Acoust. Soc. Amer.**, Vol. 55, pp.269-280 (1974).
22. J.T. Hunt, M.R. Knittel, C.S. Nichols, and D. Barach, "Finite-Element Approach to Acoustic Scattering from Elastic Structures," **J. Acoust. Soc. Amer.**, Vol. 57, pp. 287-299 (1975).
23. J.B. Keller and D. Givoli, "Exact Non-reflecting Boundary Conditions," **J. Comput. Phys.**, Vol. 82, pp. 172-192 (1989).
24. A. Bostrom, "Scattering of Stationary Acoustic Waves by an Elastic Obstacle Immersed in Water," **J. Acoust. Soc. Amer.**, Vol. 67, No. 2, pp. 390-398 (1980).
25. M.F. Werby and L.H. Green, "An Extended Unitary Approach for Acoustical Scattering from Elastic Structures," **J. Acoust. Soc. Amer.**, Vol. 74, pp. 625-630 (1983).
26. M.F. Werby and G.J. Tango, "Application of the Extended Boundary Condition Equations to Scattering from Fluid-Loaded Objects," **Eng. Anal.**, Vol. 5, pp. 12-20 (1988).
27. T.L. Geers, "Doubly Asymptotic Approximations for Transient Motions of Submerged Structures," **J. Acoust. Soc. Amer.**, Vol. 64, No. 5, pp. 1500-1508 (1978).
28. H. Huang, G.C. Everstine, and Y.F. Wang, "Retarded Potential Techniques for the Analysis of Submerged Structures Impinged by Weak Shock Waves," **Computational Methods for Fluid-Structure Interaction Problems**, ed. by T. Belytschko and T.L. Geers, AMD-Vol. 26, The American Society of Mechanical Engineers, New York, pp. 83-93 (1977).
29. Y.P. Lu, "The Application of Retarded Potential Techniques to Submerged Dynamic Structural Systems," **Innovative Numerical Analysis for the Engineering Sciences**, edited by R. Shaw, W. Pilkey, B. Pilkey, R. Wilson, A. Lakis, A. Chaudouet, and C. Marino, University Press of Virginia, Charlottesville (1980).
30. M.A. Tamm, "Stabilization of the Coupled Retarded Potential - Finite Element Procedure for Submerged Structural Analysis," Memorandum Report 5902, Naval Research Laboratory, Washington, DC (1986).
31. M.A. Tamm and W.W. Webbon, "Submerged Structural Response to Weak Shock by Coupled Three-Dimensional Retarded Potential Fluid Analysis - Finite Element Structural Analysis," Memorandum Report 5903, Naval Research Laboratory, Washington, DC (1987).
32. G.C. Everstine, "A NASTRAN Implementation of the Doubly Asymptotic Approximation for Underwater Shock Response," **NASTRAN: Users' Experiences**, NASA TM X-3428, National Aeronautics and Space Administration, Washington, DC, pp. 207-228 (1976).

33. D. Ranlet, F.L. DiMaggio, H.H. Bleich, and M.L. Baron, "Elastic Response of Submerged Shells with Internally Attached Structures to Shock Loading," **Comp. Struct.**, Vol. 7, No. 3, pp. 355-364 (1977).
34. H.C. Neilson, G.C. Everstine, and Y.F. Wang, "Transient Response of a Submerged Fluid-Coupled Double-Walled Shell Structure to a Pressure Pulse," **J. Acoust. Soc. Amer.**, Vol. 70, No. 6, pp. 1776-1782 (1981).
35. G.C. Everstine, E.A. Schroeder, and M.S. Marcus, "The Dynamic Analysis of Submerged Structures," **NASTRAN: Users' Experiences**, NASA TM X-3278, National Aeronautics and Space Administration, Washington, DC, pp. 419-429 (1975).
36. G.C. Everstine, "Structural Analogies for Scalar Field Problems," **Int. J. Num. Meth. in Engrg.**, Vol 17, pp. 471-476 (1981).
37. A. Bayliss and E. Turkel, "Radiation Boundary Conditions for Wave-Like Equations," **Comm. Pure and Appl. Math.**, Vol. XXXIII, No. 6, pp. 707-725 (1980).
38. R.H. Cole, **Underwater Explosions**, Princeton University Press, Princeton, NJ (1948).
39. H. Huang, "Transient Interaction of Plane Acoustic Waves With a Spherical Elastic Shell," **J. Acoust. Soc. Amer.**, Vol 45, No. 3, pp. 661-670 (1969).