

N91-20658 !

EVALUATION OF TELEROBOTIC SYSTEMS
USING AN
INSTRUMENTED TASK BOARD

Thomas C. Bryan
NASA/Marshall Space Flight Center
Mail Stop: EB24
Huntsville, Alabama 35812

John D. Carroll, Paul A. Gierow
SRS Technologies
990 Explorer Blvd.
Huntsville, Alabama 35806

ABSTRACT

An Instrumented task board has been developed at NASA Marshall Space Flight Center (MSFC). An overview of the task board design, and current development status is presented. The task board was originally developed to evaluate operator performance using the Protoflight Manipulator Arm (PFMA) at MSFC. The task board evaluates tasks for Orbital Replacement Unit (ORU), fluid connect and transfers, electrical connect/disconnect, bolt running and other basic tasks. The instrumented task board measures the 3-D forces and torques placed on the board, determines the robot arm's 3-D position relative to the task board using IR optics, and provides the information in real-time. The PFMA joint input signals can also be measured from a breakout box to evaluate the sensitivity or response of the arm operation to control commands. The data processing system provides the capability for post processing of time-history graphics and plots of the PFMA positions, the operator's actions, and the PFMA servo reactions in addition to real-time force/torque data presentation. The instrumented task board's most promising use is developing benchmarks for NASA centers for comparison and evaluation of telerobotic performance.

INTRODUCTION

Telerobotics systems are currently being developed and evaluated at a number of NASA centers, Universities and Air Force centers. The telerobotic systems are being developed to perform a wide range of on-orbit tasks. Space operations such as satellite servicing, assembly, maintainance and payload handling can be accomplished with telerobotic systems (ref. 1). An increased need for telerobotic support will emerge as the Space Station Freedom evolves. A baseline for evaluating telerobotic systems and tasks is needed to establish comparisons of the performance characteristics among the task analysis community. An instrumented task

board and data acquisition system can be used to further quantify parameters used for telerobotic systems and task evaluations.

TASK BOARD DESCRIPTION

The instrumented task board system consists of an inner task frame that is instrumented to measure the forces and torques placed on the board. The inner frame accepts 19" task panels which are interchangeable. A variety of tasks can be performed simply by installing the task panel desired on the inner frame. An optical position sensing system determines the position of the telerobotic end effector relative to the task panel. A voltage breakout box is supplied to measure the joint forces on the telerobot. A user-friendly data acquisition and reduction system is integrated into the measurement systems. Figure 1 is a photograph of the task board system at MSFC with an ORU replacement task panel. Figure 2 is a photograph of a fluid transfer demonstration task board used at MSFC.

Instrumented Beam Force/Torque Sensors

A 4-point suspension system design is used to fully support the inner frame of the task board. Cantilever beams instrumented with strain gauges and signal conditioners are used in order to determine the forces and torques placed on the task board. The instrumented beam design incorporates low friction instrument linear bearings combined with a spherical bearing. The instrumented beam design results in no axial loads or torques placed on the cantilevered beams. Incorporating the low friction axial and rotational mounting methods to the task board results in a perpendicularly applied load to each instrumented beam. The unique mounting method enables the instrumented beam/strain gauges to measure components of the load on the beams allowing for force component measurements.

Optical Position Sensors

The purpose of the position monitoring system included in the instrumented task board is to record quantitative data that can be reviewed and used as an evaluation and learning tool for the development and sharpening of the operator's PFMA skills and task evaluations. The 3-D position sensing system enables the controller to know the precise coordinate or location of the end effector tool being used, in reference to the center of the task board. This system is comprised of two Hamamatus (C2399) two-dimensional position sensor systems. Each position sensor system is a compact high-resolution position sensor using a non-discrete position-sensitive detector. The non-discrete position-sensitive detector enables high-speed measurement of a moving spot with high accuracy. The position sensor is an opto-electric unit which measures the position of a single-point of infrared light focused on the sensor head. The two dimensional position sensor systems are comprised of a system controller, an infrared lens and sensor head, and a seven infrared LED cluster target.

Each two-dimensional position sensor is monitored by the Macintosh II through an analog-to-digital input/output board. The position of the target, which is mounted near the PFMA's end effector, is recorded by the sensor head. The two dimensional coordinates are transmitted as an analog input to position controller. The sensor heads are located at 90° angles from each other relative to the center of the instrumentation board, as shown in Figure 3. By placing the sensors heads 90° apart, the three dimensional envelope of coverage resembles an odd shape cube. The sensors' analog outputs are read into the computer where they are stored in a file and plotted, in real-time, on the computer monitor.

Data Acquisition System

The data acquisition system monitors and records the interaction of the PFMA operator with the instrumented task board and each position sensor unit. The data acquisition for the system is achieved through the use of a Macintosh II, LabVIEW control software, and an analog-to-digital input/output PC board in series with an analog multiplexer board. The system's set up is shown in Figure 4.

The Macintosh II consists of a 40 mega byte hard drive, 5 mega bytes of RAM, 4 bit color video monitor card, color high-resolution monitor, and standard keyboard. The analog-to-digital input/output board (NB-MIO-16L-25) and the analog multiplexer (AMUX-64), developed by National Instruments, provides the computer with the ability to perform data acquisition on a maximum of 64 channels. The computer system is controlled with LabVIEW, a data acquisition and control graphical software developed by National Instruments. Hard copies of the raw test data and graphs of the test performance are obtained from the Image Writer II, a dot matrix printer. This computer system provides a user friendly environment along with efficiency.

Data Acquisition System Software

LabVIEW serves as a software driver and controller for the NB-MBIO-16 and AMUX-64 hardware data acquisition boards installed in the Macintosh II. LabVIEW is a complete programming environment which allows the user to construct virtual instruments (VI's) that control and record operations that are required. The final instrument design includes integration of the sub-virtual instruments into a single virtual instrument for simultaneous data acquisition and real-time monitoring.

The building block of LabVIEW is the Virtual Instrument (VI). The Virtual Instruments in LabVIEW are the software components of the complete data acquisition and control system installed in the Macintosh II. Each VI has a front panel which specifies the inputs and outputs of the program. Figure 5 depicts the controls and indicators of the real-time measurement system. Behind the front panel in LabVIEW is a block diagram which represents the actual executable program. The block diagram represent graphical programming functions that are standard in any programming environment. Any virtual instrument that is designed can be represented as an icon that can be included in other VI's. The hierarchical structure of LabVIEW enables the user to construct complicated control and acquisition systems from combining the Virtual Instruments into one complete Virtual Instrument.

Data Acquisition System Capabilities

The data acquisition system on the Macintosh II for the arm sensor system is driven by the LabVIEW software. The data acquisition

requirements of the arm sensor system include reading and storing to disk analog signals from the strain gage conditioning circuits from the task board, position sensors and current proportional voltages from the PFMA servomotors. Information from the PFMA operator via RS-232 data lines was included in the data acquisition and storage system on the Macintosh II. A summary of the operations of the data acquisition and storage system are shown in Table I.

<p>Force Measurements</p> <ul style="list-style-type: none"> • Acquisition of the Strain Signals from the Instrumented Task Board • Conversion of the Strain Data to Force Data • Calculation, Reading and Real Time Graphical Presentation of the 3-D Forces Applied to the Instrumented Task Board <p>Position Measurements</p> <ul style="list-style-type: none"> • Acquisition of the Position Sensors' Outputs • Calculation of the PFMA's 3-D Positive Relative to a Chosen Origin • Recording and Graphical or Numerical Presenting the 3-D Location of the PFMA in Reference to a Chosen Origin <p>PFMA Servomotor Measurements</p> <ul style="list-style-type: none"> • Acquisition of the Current Proportional Voltages from the PFMA's Servomotors • Calculation of Power Used by Each Servomotor, During Operations (if required) • Resolve Joint Voltages to Task Analysis Primitives <p>PFMA Control Life Information</p> <ul style="list-style-type: none"> • Record all PFMA's Control Line Information Which is Transmitted Over an RS-232/422 Data Bus
--

Table I. Current Measurement Capabilities

A double buffer acquisition system is used in LabVIEW. The system allows the programmer to store information in a buffer while scanning the channels of interest on the A/D board. The buffer is then periodically read and stored to the desired output file on the computer. The data is also plotted on the screen while simultaneous data acquisitions are occurring. An external gate is also used for triggering of data acquisitions. The external gate enables data acquisitions while the gate is held in a high position. The external gate enables the board to perform a scan of the channels at a high rate but allow for a delay time between each scan. The delay time is determined by the desired acquisition rate.

The operator commands via the RS-232 data line can be read by LabVIEW using an RS-422 port

read virtual instrument. The instrument reads the contents of the RS-422 buffer. The buffer size can be configured by the user. Simultaneous analog data acquisition and RS-422 buffer storage is available if desired. The RS-422 buffer read VI can be incorporated into the data acquisition VI.

CONCLUSION

Currently there are no standards for laboratory comparisons of telerobotic systems. The instrumented task board design developed to evaluate the PFMA at MSFC could be useful for establishing a benchmark tool to evaluate telerobotic systems within the NASA centers. The data taken from the instrumented task board could be used as a departure point for technical discussions among NASA centers. The task board will support standardization and further define task analysis for telerobotics. Additional task sets can be added to the task board design to include a variety of tasks that include collision avoidance, adjustable inertia crank, lighting systems and dynamic situations.

ACKNOWLEDGEMENTS

This research and development is currently being supported by the Information & Electronics Laboratory, NASA Marshall Space Flight Center (Contract #NAS8-36307). Mr. Thomas C. Bryan is the technical monitor.

REFERENCES

1. Drews, Michael, "General Extravehicular and Telerobotic Task Primitives for Analysis, Design, and Integration," JPL Publication 89-XXX, Draft 1.5, Jet Propulsion Laboratory, Pasadena, CA, January, 1990.
2. Price, Charles, "Status of Benchmark Task/ Task Boards," Telerobotics Intercenter Working Group, Johnson Space Center, TX, July 25, 1989.

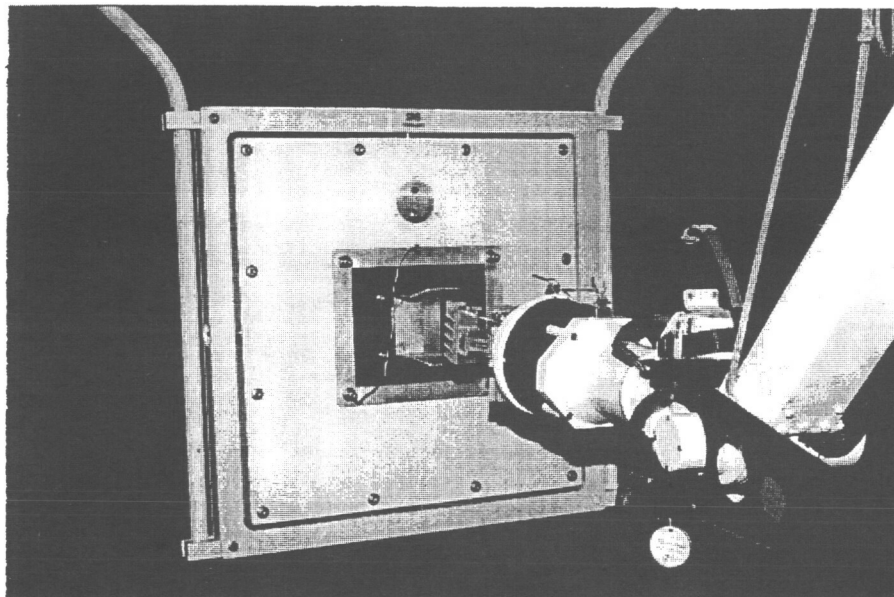

Figure 1 Instrumented Task Board

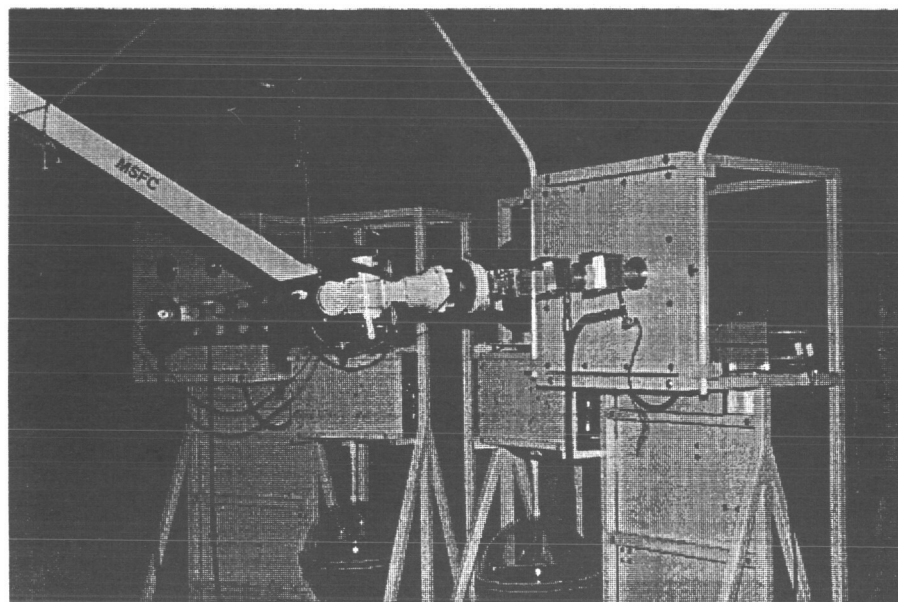

Figure 2 Fluid Transfer System

ORIGINAL PAGE
BLACK AND WHITE PHOTOGRAPH

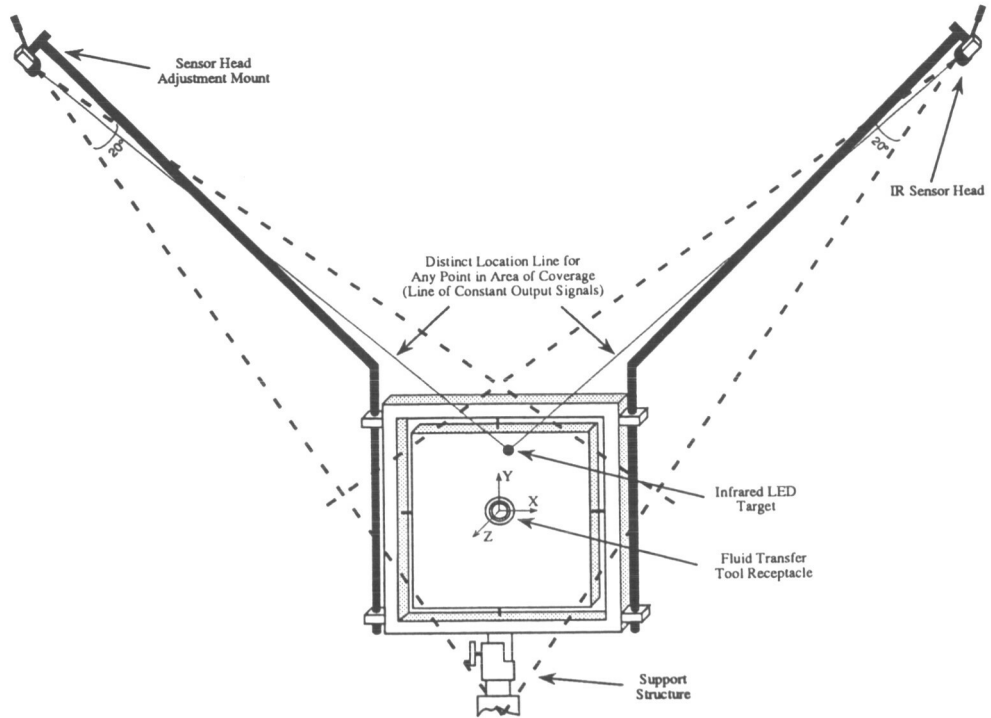

Figure 3 IR Position Sensor System

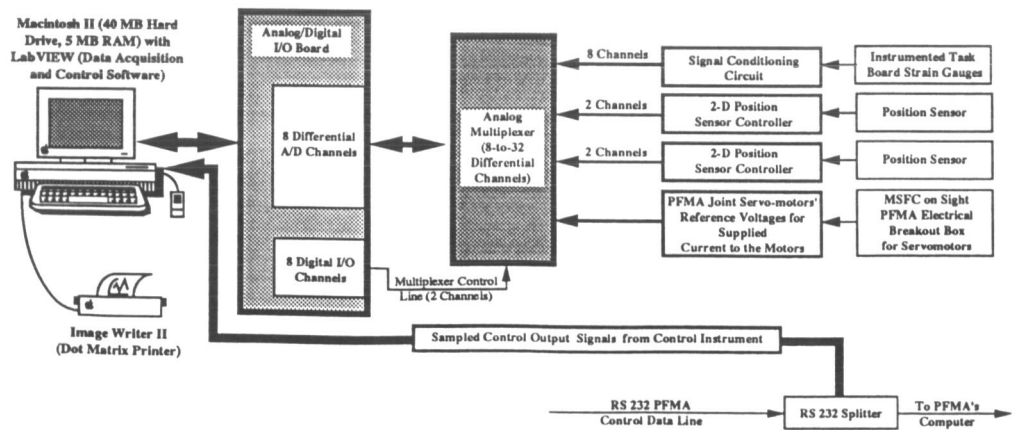

Figure 4 Electronic Data Acquisition System

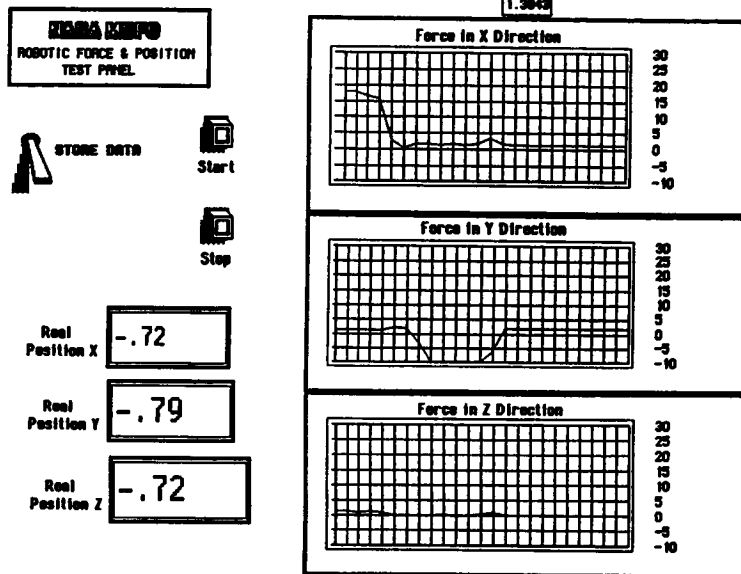

Figure 5 "Real-Time" Data Acquisition Panel