

N91-20661

THE DEVELOPMENT TEST FLIGHT
of the
FLIGHT TELEROBOTIC SERVICER

J. Andary and P. Spidalieri
Goddard Space Flight Center
Greenbelt, MD 20771

R. Sosnay
Martin Marietta Astronautics Group
Denver, CO 80201

ABSTRACT

The Development Test Flight (DTF-1) is the first of two shuttle flights to test operations of the Flight Telerobotic Servicer (FTS) in space and to demonstrate its capabilities in performing tasks for Space Station Freedom. The DTF-1 system, which Martin Marietta Astronautics Group is designing and building for the Goddard Space Flight Center, will be flown in December, 1991, as an attached payload on the shuttle. This article discusses the design of the DTF-1 system, the tests to be performed, and the data to be gathered.

INTRODUCTION

The FTS project was formed in 1986 as part of the space station work package 3 at Goddard Space Flight Center to develop a telerobotic device for performing assembly, maintenance, servicing and inspection tasks on the space station [1,2]. Before the final version is launched on one of the early space station assembly flights, there will be two early shuttle test flights: the Development Test Flight (DTF-1), now scheduled for launch in late 1991, and the Demonstration Test Flight (DTF-2), scheduled for launch in late 1993. The preliminary design review for DTF-1 was held July, 1989, and the critical design review is scheduled for September, 1990.

From the initial beginnings of the FTS project, it was recognized that an early development flight would be necessary in order to validate the FTS hardware design and to gather critical engineering test data for ground evaluation and calibration of the ground testing facilities. The DTF-1 was designed under the ground rule that the standard shuttle allocations for a quarter-bay payload be used where possible in order to contain costs and to maintain schedule.

The DTF-1 configuration consists of a payload bay element and an aft flight deck element. The payload bay element [figure 1] contains the telerobot with a single manipulator and all associated equipment, such as end-of-arm tooling, cameras and lights, task elements, and support avion-

ics. The payload bay element primary support structure is a Multi-Purpose Experiment Support Structure (MPSS) which mechanically attaches the DTF-1 hardware to the shuttle.

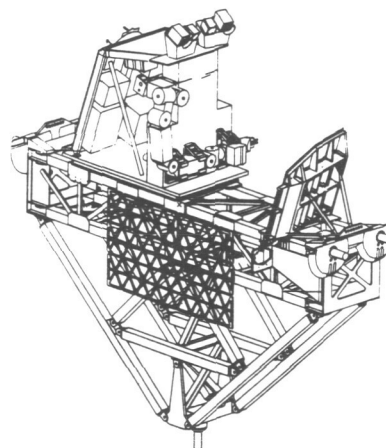

Figure 1. Configuration of Payload Bay Element for the Development Test Flight

The aft flight deck element consists of the control panels, the hand controller, and the crew restraint system, which are removable and stowable in the mid deck locker. In addition there are permanently mounted electronic boxes in the L-10 and L-11 panels.

MISSION OVERVIEW

MISSION OBJECTIVES

The DTF-1 flight hardware, flight software, task elements and mission timeline have been designed to meet the following mission objectives:

1. Evaluate the telerobot manipulator design approach
2. Evaluate the shuttle workstation design approach
3. Correlate system performance in space with ground simulation and analyses
4. Evaluate human-machine interface and operator fatigue
5. Demonstrate telerobot potential capabilities

The manipulator includes the camera assembly mounted on the wrist roll assembly to allow the operator to closely view the end effector and tool and the objects to be manipulated. The camera will be discussed further in the vision subsystem section.

A redundant force/torque transducer (FTT) is mounted on the end of the manipulator. The FTT contains two independent strain gauge elements and associated electronics for measuring the forces and torques produced at the tool plate. The output of the FTT consists of two sets of six differential, analog signals which roughly correspond to the six independent components of the force and torque vectors. The analog outputs are provided to two independent controller electronics which digitize and calibrate the signals to generate a digital representation of the force and torque vectors at the FTT.

The manipulator tool plate allows power, data and video to be passed through to the end effector. The DTF-1 will fly a single end effector with a simulated end effector changeout mechanism (EECM). The EECM will be used in future missions to permit replacement of end effectors and tools. The DTF-1 end effector will be a single parallel jaw gripper which will perform all the mission tasks. The end effector consists of a brushless dc motor; pancake harmonic drive transmission; redundant finger position and output torque sensors; redundant, fail-safe brakes and associated gear reduction; sensor amplifiers; wiring; and connectors. The fingers are integral to the end effector and interface to the tasks using a dedicated interface. The end effector provides a peak gripping force of 50 lbs. over a 4-inch gripping range.

Task Panel

The DTF-1 task panel [figure 4] is mounted on the MPSS in front of the manipulator. The task panel holds the task elements which are designed to test the FTS's capability to meet the mission requirements. They consist of a peg-in-hole pattern, a contour board, a space station truss node, a space station fluid connector, and a removable mass.

Data Management and Processing Subsystem (DMPS)

The DMPS is a distributed system of computers, controllers, data and video recorders, and hardware control system that supports the DTF-1 software and system architectures. These electronics are connected through MIL-STD-1553b buses for data transfer.

The DTF-1 configuration consists of one telerobot control computer and eight controllers. The telerobot control computer

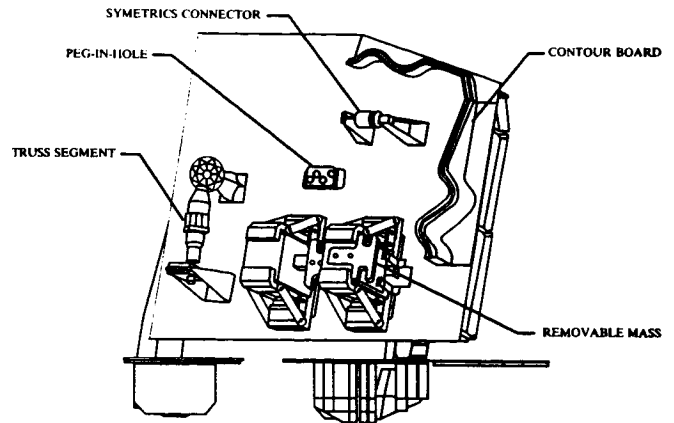

Figure 4. Task Panel

is a prototype of the Space Station Freedom data processor. It contains two 20 MHz CPUs with 4 MBytes memory. The telerobot control computer is the primary control processor. In the forward loop, it takes commands from the hand controller, computes the inverse kinematics, and produces the required motion at the manipulator. In the return loop, the control computer receives inputs from the FTT, computes force feedback commands for the hand controller, and performs boundary management/touch control and housekeeping safety checks.

The eight controllers include the display assembly controller and hand controller drive electronics located in the workstation, three controllers located in the manipulator, the telerobot redundant controller located on the MPSS, the power module controller, and the payload bay controller. The display assembly controller and the hand controller drive electronics provide the operator interface through the control and display panel and hand controller respectively. The manipulator controllers perform the position, rate, and torque servo loop calculations and drive the joint actuators and gripper. The telerobot redundant controller collects accelerometer data and performs backup boundary management/touch control checks and housekeeping checks. The power module controller monitors power subsystem voltages and currents and controls power switching. The payload bay controller provides uplink and downlink through the shuttle and controls the head cameras and caging mechanisms. A typical controller consists of a CPU board with an 80386, 20 MHz processor and 256 MBytes memory, a 22 channel analog acquisition board, an input/output board, and a power supply board.

The data recorders are used to initialize the software and store on-orbit engineering data. Initialization takes place through the MIL-STD-1553b buses. Software load files are pre-recorded before launch.

Software files may be uploaded or downloaded while on orbit through the shuttle multiplexer/demultiplexer and payload data interleaver respectively.

The software architectural design defines an organization of software components corresponding to the NASA/National Bureau of Standards (NBS) Standard Reference Model for Telerobot Control System architecture (NASREM), which is the FTS system functional architecture [3]. It also defines software components to support communications between NASREM modules, task scheduling, and initial program load. This design consists of a set of top-level computer software components that correspond to processor and read-only memory device load modules and one set of lower level computer software components, most of which correspond to NASREM modules.

The detailed software design is expressed in the Ada Program Design Language (PDL), which is the adopted machine-compatible, higher order language for space station. The PDL permits the design to be expressed in such a way that a compiler can be used to check the consistency of interfaces. All Ada specification sections are provided in the detailed design, and components (e.g. functions, procedures) in the body sections are filled in to the extent that the compiler can perform its function. The remainder of the body may be filled in with Ada expressions or descriptions of the processing logic of the components.

Power Subsystem

The power subsystem interfaces electrically with the shuttle's power system, conditions this power to meet the needs of the telerobot and distributes the power to the DTF-1 subsystem loads. The power subsystem also performs the power switching required by subsystem loads; performs line filtering and EMI power quality filtering; provides power health status reports to the computers; and permits a safe power-up and power-down sequence.

The power subsystem generates three voltages from the 28 VDC the shuttle provides. These are 120 VDC for the motors and brakes, unregulated 28 VDC for the DMPS and thermal control subsystems, and regulated 28 VDC for the cameras and lights. Future missions will use a regulated and unregulated 120 VDC system.

Vision Subsystem

The vision subsystem includes one manipulator wrist-mounted camera, two head-mounted cameras, and camera lights. The cameras are color and use charge coupled device (CCD) technology. They and the lights are controlled from the workstation.

The vision subsystem will be used in conjunction with the shuttle's closed circuit TV system. The camera video output will interface to the shuttle's video switch and be displayed on the existing shuttle monitors. The output will also be recorded on the workstation video recorders.

The wrist camera gives the operator a view of the end effectors, permitting intricate tasks to be performed and allowing close-up inspections of completed work. The head cameras each provide fixed views of the worksite.

AFT FLIGHT DECK ELEMENT

The operator controls the telerobot and conducts the DTF-1 operations from the aft flight deck of the shuttle. The workstation is situated in the port-side corner of the aft flight deck close to the shuttle remote manipulator system (RMS) controls and uses the shuttle-provided TV monitors that are located in that corner.

The system is designed to be controlled by a single operator, although an observer may be used during the operation. Direct viewing of the telerobot will not be required; however the operator will be able to see it through the aft flight deck windows.

Workstation Subsystem

The workstation [figure 5] provides the man-machine interface in the shuttle aft flight deck for DTF-1 operations. It uses common hardware with the Space Station Freedom workstation and shuttle services hardware. The DTF-1 camera views will be displayed on the existing Shuttle displays. The shuttle-provided payload and

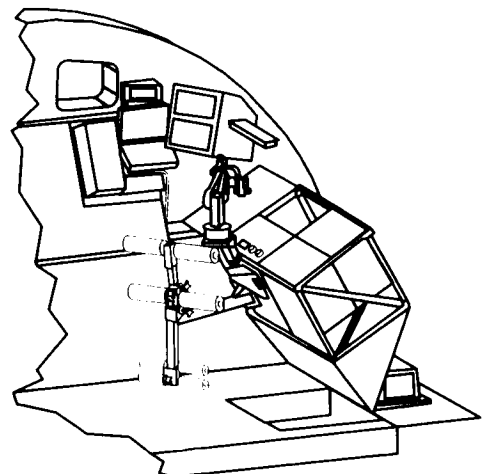

Figure 5. General Layout of the Aft Flight Deck for the Development Test Flight

general support computer (PGSC) will be used to display system status and function. The workstation operator uses the functions keys and the numeric and cursor keypad functions of the PGSC keyboard for menu and data entry operation. A separate control and display panel (C&DP) has a section of switches, indicators, and annunciators for manual control, emergency shutdown, and mode control. The PGSC and C&DP are mounted to a common plate, which is mounted to the A8 panel. The workstation configuration also incorporates a power control and distribution unit (PCDU), display assembly controller, a crew restraint system, a 6-DOF hand controller, and hand controller electronics.

Communication among the DTF-1 subsystem electronics elements is over a MIL-STD-1553b bus. This bus carries data from the workstation to the telerobot subsystems. Such data includes joint positions from the hand controllers and mode commands from the control and display panel. In the opposite direction, after being transformed by the telerobot control computer, manipulator force/ torque data is transmitted over the bus for feedback to the operator through the hand controller. Health and status and alert information is also transmitted over the bus for data storage, analysis, and display to the operator on the PGSC.

Within the workstation subsystem, the PCDU controls and monitors power distribution to the workstation electrical hardware. Video from the DTF-1 head and wrist cameras will be routed through the shuttle's video switch to the two shuttle monitors. These same signals will be recorded on the two shuttle video recorders located in the L10 panel. The operator will use the PGSC keyboard through the display assembly or the control and display panel controller to control the cameras.

Hand Controller

The DTF-1 hand controller is the Martin Marietta/Kraft 6-DOF, force-reflecting, hand controller [figure 6]. The hand controller is based on a mature design that

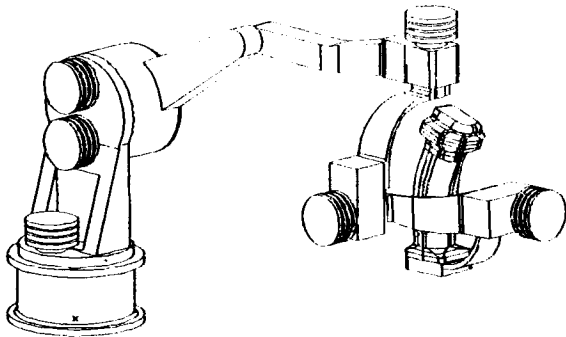

Figure 6. Hand Controller

has been used in nuclear and undersea applications since 1980.

The hand controller supports rate and position control with and without force reflection. It can provide 5 pounds of force and 9.5 inch-pounds of torque into the operator's hand. The hand controller electronics consist of a computer, analog to digital converter, input/output device, and pulse-width modulated power drivers.

Each hand controller joint consists of an induction motor and gearing, motor heat sink, potentiometer-based position sensor, and housings and bearings. The shoulder and elbow joints contain additional speed reduction. High gear ratios (200:1 in the wrist joints) are used in conjunction with low inertia motors and gears.

The detachable hand grip is similar to bottom-mounted, flight joysticks. It has an activation switch, which activates the hand controller and permits reindexing of the hand controller-to-manipulator transformation; an end effector enable switch, which enables the end effector to open or close; and the end effector rocker switch, which commands the end effector fingers to open or close.

Crew Restraint System

The crew restraint system consists of pairs of adjustable padded bars which act to restrain the operator from the hips down. It provides restraint in all axes, permitting safe force reflecting operations in zero gravity.

The restraint system is designed to accommodate operators sized from a 95 percentile American male to a 5 percentile Japanese female. The system also has a high crossbar vertical section that can rotate to place the pads against the front or rear of the thighs. The entire system can be rotated and tilted on the adapter so the operator can be placed at the centerline of the monitors and 28 inches away from the monitors. In this location, he/she can easily reach the C&DP and the PGSC and maneuver the hand controller throughout its operating envelope.

Hardwire Control

The C&DP has switches for bypassing the computers and directly controlling the telerobot, cameras and lights, individual manipulator joints, manipulator and mass caging mechanisms, and the end effector. This hardwire control system permits stowage of the payload in the event of certain failures of the DTF-1.

A safety emergency shutdown (ESD) switch on the C&DP allows the operator to safely shut down the telerobot. In the shuttle,

this switch will be hardwired to the robot power distribution hardware. Activation of this switch will cut all power to the manipulator motors and brakes. The other subsystems will not be affected.

OPERATIONS

DTF-1 mission objectives will be met through a sequence of 12 tasks to be performed during the 16-hour mission timeline. The first is an initial system familiarization demonstration. The remainder of the mission activities are grouped into six performance verification tasks and five capabilities demonstration tasks.

SYSTEM FAMILIARIZATION DEMONSTRATION

This task will demonstrate that the DTF-1 system and the operator are ready for performing the on-orbit DTF-1 tasks. First, the manipulator and end effector will be positioned well away from any surfaces or objects that could be inadvertently contacted. Then the following tests will be conducted:

- 1) Test the boundary management/touch control system. The purpose will be to verify that motion outside the workspace will not occur. The operator will deliberately attempt to move the manipulator outside of the artificially established boundaries defined in the software specifically for this test.

- 2) Test the control available for single joints. This test will confirm if the operator can control the performance of single joints from the control panel.

Other tests will be to control and adjust the camera; operate the manipulator first with the handcontroller and then with the hardware system; control the manipulator using various combinations of control mode, reference frames, and scale factors; control the gripper with the C&DP and hardware system; and reindex the hand controller.

PERFORMANCE VERIFICATION TASKS

Fine Positioning Test

This test is an automated sequence that will test the performance of the manipulator to ensure that accuracy, incremental control, and repeatability performance requirements are met. The accuracy test will be performed using the wrist camera and an inverse prospective technique. The repeatability and incremental motion tests will be performed using joint position sensors and forward transformation to the tool plate. The ISO definitions, equations, and approaches will be used to determine the results.

Operational Envelope Evaluation

This automated sequence will evaluate the performance of the manipulator at workspace extremes, test enroute velocity and workspace limits, and demonstrate recovery when limits are exceeded.

Manipulator Dynamics Model Verification

This task has two purposes: Test a joint closed loop actuator and structural dynamics model and verify on-orbit stability margins and the performance of the position-based impedance control.

For the joint closed loop actuator and structural dynamics model test, automated sequence inputs will be given to the seven joints, one at a time. The test will be performed for three different arm configurations, with the arm unloaded and then loaded with the gripper holding the 25-pound mass. The mass will be grasped to verify the performance with different inertias.

For the automated impedance test, the manipulator will be rigidly connected to the center handle of the caged mass and then a step force or position command will be given in all 6-DOF.

For the teleoperated tests, the operator will use the handcontroller and different force reflection gains to command gross motions of the loaded manipulator. Different spring return forces will be used to test the resolved rate mode and determine its operation.

Manipulator Non-linear Model Verification

This task provides the data to characterize and verify the non-linear model of the joints. Automated signal input sequences will be input, one at a time, to shoulder pitch, elbow pitch, and wrist pitch. Joint brakes except for the joint being simulated will be ON. This task will be performed for three thermal conditions and in conjunction with the thermal transient response tests.

Thermal Transient Response

This task will test the thermal capacitance of the thermal control subsystem while evaluating manipulator performance under different thermal environments.

CAPABILITIES DEMONSTRATION TASKS

Peg-in-Hole Demonstration

An operator will use teleoperator control to insert a peg mounted on one of the fingers into four different-sized holes. A video of the insertion and a transcript of the operator's comments will provide data,

including preciseness of peg insertion, depth of insertion, difficulties completing the task, and human-machine interface data, such as control preferences and hand controller feel, predicted stability, operator fatigue, and teleoperational mode performance margins.

Contour Board Tracking

This task will evaluate impedance control and force reflection during end-point tracking tasks and provide engineering data for evaluating the human-machine interface. An operator will use teleoperation to control a peg in tracking curved, straight-line and V-shaped machined tracing paths, 3-D trajectories over rough surfaces, sloping plane surfaces and convex, or concave contour surfaces. The task will be performed with and without force reflection but with active impedance control. Data collected will include the operator's comments during the task and a video of the peg tracing the surface.

Connector Demate/Mate

The gripper will demate and mate a Symmetrics connector, which will require multiple revolutions of its collar for locking and unlocking. This task is representative of an FTS task to be performed on Space Station Freedom. The engineering data generated will be used to determine the operational performance of the impedance controller, bilateral force reflection, and manipulator safety limits and to evaluate the human-machine interface. The gripper will unlock and separate the connector halves. Then the gripper will mate the connector halves, lock them, and apply a small lateral force to verify the integrity of the connection. Throughout the repetitions of this task, the force reflection gain will be varied as a function of different gains. Task completion times and contact force levels will be used to measure operator fatigue.

Truss Strut Element Removal/Replacement

This task is another FTS-like task in which a Space Station Freedom truss strut element will be removed and replaced. The gripper will grasp the collar on the truss strut element mounted on the task panel and unlock and relock it. The strut will then be partially demated from the strut attachment fitting mounted on the node. Engineering performance data on the impedance controller, force reflection, and manipulator safety limits will be generated. Human-machine interface and operator fatigue will be evaluated from operator comments and a video of the task.

Removable Mass Manipulator Loading Test

A 25-pound removable mass that is caged to the task panel is provided to enable eval-

uation of the manipulator performance in both a loaded and unloaded configuration. Two separate handles are provided on the mass for gripper attachment. The handle designs will incorporate mating interfaces matching the dedicated handle grasping interface of the end effector. One handle is located on the center of gravity of the mass and the other is located off the center of gravity in order to evaluate different inertial loadings of the manipulator. The removable mass is the only removable part of the task elements. A caging mechanism, similar in design to the lower arm caging mechanism, is provided for the restraint of the mass.

SAFETY

The design of the DTF-1 system is driven heavily by safety considerations. Mission procedures focus on maintaining the integrity of the shuttle and protecting the crew. The DTF-1 design ensures survivability after being subjected to normal or emergency landing loads and post-landing delays.

The telerobot may be shut down in three modes: Normal shut down, manual emergency shut down, and automatic emergency shut down. In normal shut down, the operator can command the telerobot to shut down after it has completed work or when a failure occurs that is not hazardous to the crew. The shutdown command may include stowage of task element hardware.

In manual emergency shut down, the operator may command shut down of the telerobot from the DTF-1 workstation at which DTF-1 operations are being monitored and controlled. This mode will be used to respond to DTF-1 failures that might be hazardous to the crew, the shuttle structure, or the telerobot.

Automatic emergency shut down will allow the telerobot to shut itself down in the event of a self-diagnosed failure or other unsafe condition. Such conditions include the failure of the shuttle or support system to supply required power and/or data links and the possibility of the telerobot colliding with itself or other structures. The telerobot will shut itself down automatically when these failures occur or when an out-of-limits condition exists. After corrective actions or workarounds have been implemented, the operator can go through the normal startup and checkout procedures to continue working. If the arm becomes partially inoperable, degraded mission operations could continue. The safety of the crew and the shuttle will be considered to be paramount. Those tasks that require full operability and that were not completed when the arm failed will be removed from remaining mission profile timeline. The hardwire control scheme will be implemented to restore the

manipulator in the event a failure precludes computer control of the arm.

In the unlikely event that a failure or series of failures prevents the manipulator or removable mass from being restowed by the normal method or by hardwire control, there is equipment that will allow the DTF-1 payload to be jettisoned using the shuttle RMS.

A third hazard control will be to use EVA to restow the payload for safe shuttle reentry and landing. The manipulator and gripper are designed so that an astronaut on EVA can manually release the brakes on them if they fail and backdrive the system into the correct position for caging. If a manipulator joint seizes, thereby preventing restow, the astronauts can remove the manipulator at the shoulder and stow it on the failed manipulator arm storage system (FMASS) which is attached to the MPSS.

CONCLUSION

During the 16 hours of mission operation, the Development Test Flight will return valuable engineering data on the performance of the FTS manipulator in zero gravity and on the human-machine interfaces necessary for the efficient operation of a teleoperated system from the aft flight

deck of the shuttle. This data will be analyzed post flight, and the results will be used in the development of the final flight system which will be used in the assembly and maintenance of Space Station Freedom.

REFERENCES

1. Andary, J.; S. Hinkal; and J. Watzin; "Design Concept for the Flight Tele-robotic Servicer (FTS)," presented at the 2nd Space Operations Automation and Robotics Workshop (SOAR88), Dayton, OH, July 20-23, 1988; NASA Conference Publication CP-3019, pp. 391-396.
2. Andary, J.; K. Halterman; K. Hewitt; and P. Sabelhaus; "The Flight Telerobotic Servicer (FTS): NASA's First Operational Robotic System," presented at the 3rd Operations Automation and Robotics Workshop (SOAR89), Houston, TX, July 25-27, 1989; NASA Conference Publication CP-3059, pp. 311-318.
3. Albus, J.; H. McCain; and R. Lumia; NASA/National Bureau of Standards (NBS) Standard Reference Model for Telerobot Control System Architecture (NASREM), SS-GSFC-0027, December 4, 1986.