

N91-21191

A SUPERCONDUCTING LARGE-ANGLE MAGNETIC SUSPENSION

James Downer, James Goldie, Richard Torti

SatCon Technology Corporation

12 Emily Street

Cambridge

MA 02139-4507

A Superconducting Large-angle Magnetic Suspension

James Downer, James Goldie, and Richard Torti

SatCon Technology Corporation
12 Emily Street
Cambridge, MA 02139

Presented at: Workshop on Aerospace Applications of Magnetic Suspension Technology
NASA Langley Research Center, Hampton, VA; September 25, 1990

Low-noise torque sources will be used to control and point large future missions such as Space Station, co-orbiting platforms, and the Hubble Space Telescope. Conventional torquing actuators will have problems in terms of life and vibration. On Earth, magnetic suspensions using superconductors are desirable in applications in which large clearance spaces or extreme precision is needed.

SatCon Technology Corporation has been developing the component technologies required for an advanced control moment gyro (CMG) type of slewing actuator for large payloads. The key component of the CMG is a large-angle magnetic suspension (LAMS). The LAMS combines the functions of the gimbal structure, torque motors, and rotor bearings of a CMG. The LAMS uses a single superconducting "source coil" and an array of cryoresistive "control coils" to produce a specific output torque more than an order of magnitude greater than conventional devices.

SatCon is currently designing, developing, and testing a laboratory-scale superconducting LAMS. The LAMS system is based around an available superconducting solenoid, an array of twelve room-temperature normal control coils, and a multi-input, multi-output control system. The purpose of the experiment is to demonstrate the control laws for stabilizing and controlling the LAMS system. The controller is, of course, the key component of most magnetic suspension systems.

1. INTRODUCTION

This paper discusses the ongoing development of a novel magnetic suspension system technology demonstration experiment at SatCon Technology Corporation. The goal of this program is to demonstrate an innovative approach to the design of magnetic suspension systems in which a superconducting coil is employed in order to eliminate conventional magnetic cores and permanent magnets. The design was motivated by recent progress in superconducting materials and by the requirements for an advanced control moment gyro (CMG) type of slew actuator which is currently under development. The slew actuator is intended for use with large spacecraft.

SatCon is currently working toward the demonstration of superconducting large-angle magnetic suspension (LAMS) technology in the laboratory by designing, developing, and testing a reduced-scale superconducting LAMS system. The laboratory system is based around a commercially-available superconducting solenoid and an array of twelve room-temperature normal control coils. The purpose

of the experiment is to demonstrate the required control system technology. The controller is, of course, the key component of most magnetic suspension systems.

2. BACKGROUND

Slewing of large payloads will require control torque and angular momentum storage capacities that are large in comparison to the capabilities of available actuators.

Control Moment Gyros

The most common type of momentum exchange effector, the control moment gyro (CMG), exchanges angular momentum by varying the angular orientation of a constant-speed flywheel through the use of gimbals. Figure 1 describes the acceleration phase of a slew maneuver in terms of applying a torque to a spacecraft over a fixed period of time. The torque is applied through the azimuth-axis torquer. The flywheel precesses about the elevation axis to conserve angular momentum.

The Large-angle Magnetic Suspension (LAMS) [3]

The use of a mechanical gimbal structure such as the one shown in Figure 1 is the conventional approach for CMG design. An alternative approach which consolidates the functions of mechanical bearing and gimbal systems has been demonstrated. A large-angle magnetic suspension (LAMS) is a five-axes, actively-controlled magnetic bearing designed to accommodate a certain amount of angular motion about the lateral axes of the flywheel [1,2]. Research [2] indicates that the mass of a LAMS can be made to be less than that of a gimbal system by a factor five (depending on the amount of angular freedom).

The Superconducting LAMS

A superconducting LAMS is an advanced design which may be used in a CMG to deliver large torques to a spacecraft without the need for an excessively massive magnetic core or the consumption of a large amount of power. The superconducting LAMS, as its name suggests, employs a superconducting coil and thus eliminates all conventional magnetic structures in order to produce an energy-efficient, light-weight design.

Figure 2 is a partially cut-away view which shows the rotating components (superconducting coil and flywheel) and cryogenic housing of a two-degree-of-freedom CMG which employs a superconducting LAMS. The superconducting "source" coil is a solenoid which operates without an electrical input. The current in the solenoid persists because of the lack of resistance in the superconducting material. The spherical case which surrounds the rotating components also serves as the cryostat for the superconducting solenoid. The superconducting LAMS employs a total of twelve (12) normal (non-superconducting) "control" coils which interact with the fields produced by the source coil solenoid in order to apply forces and torques.

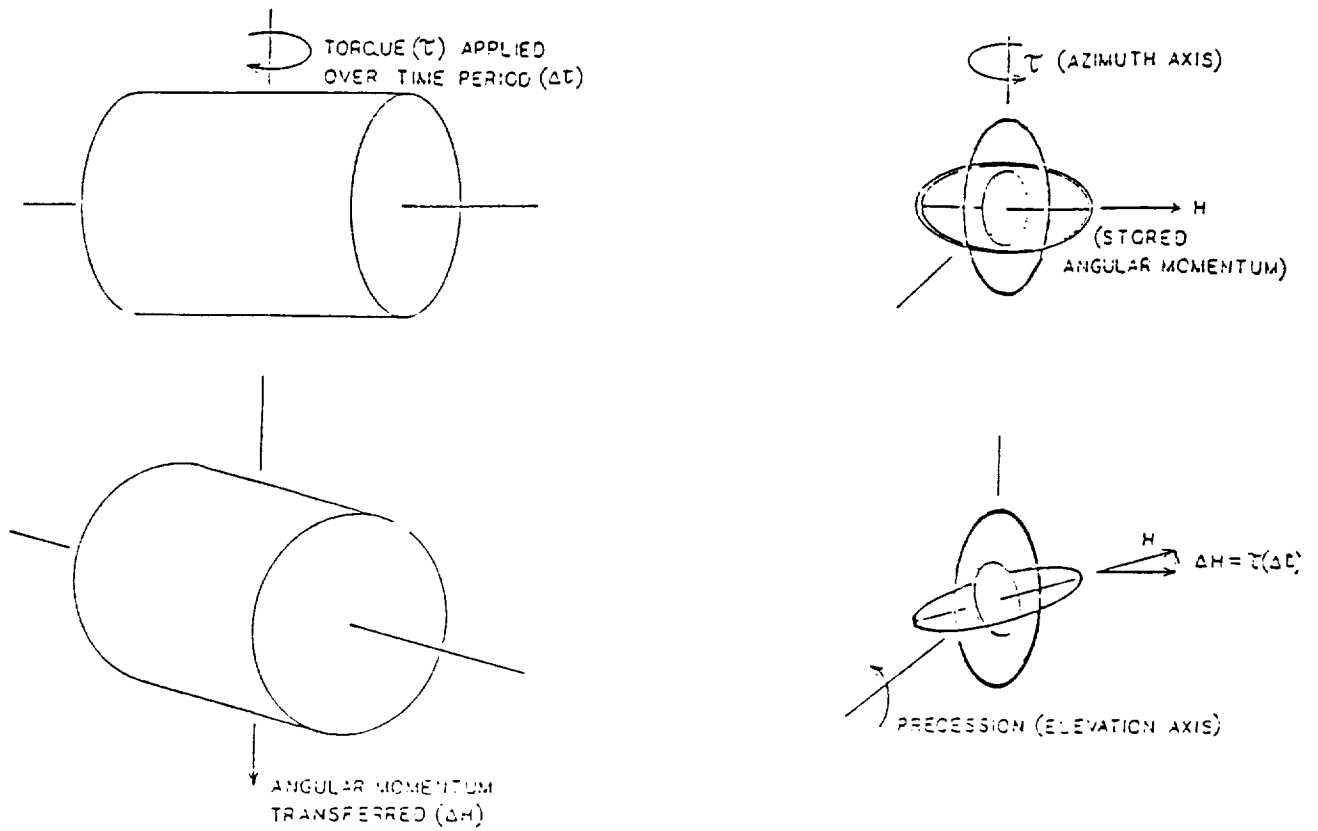

Figure 1. CMG Operating Principle

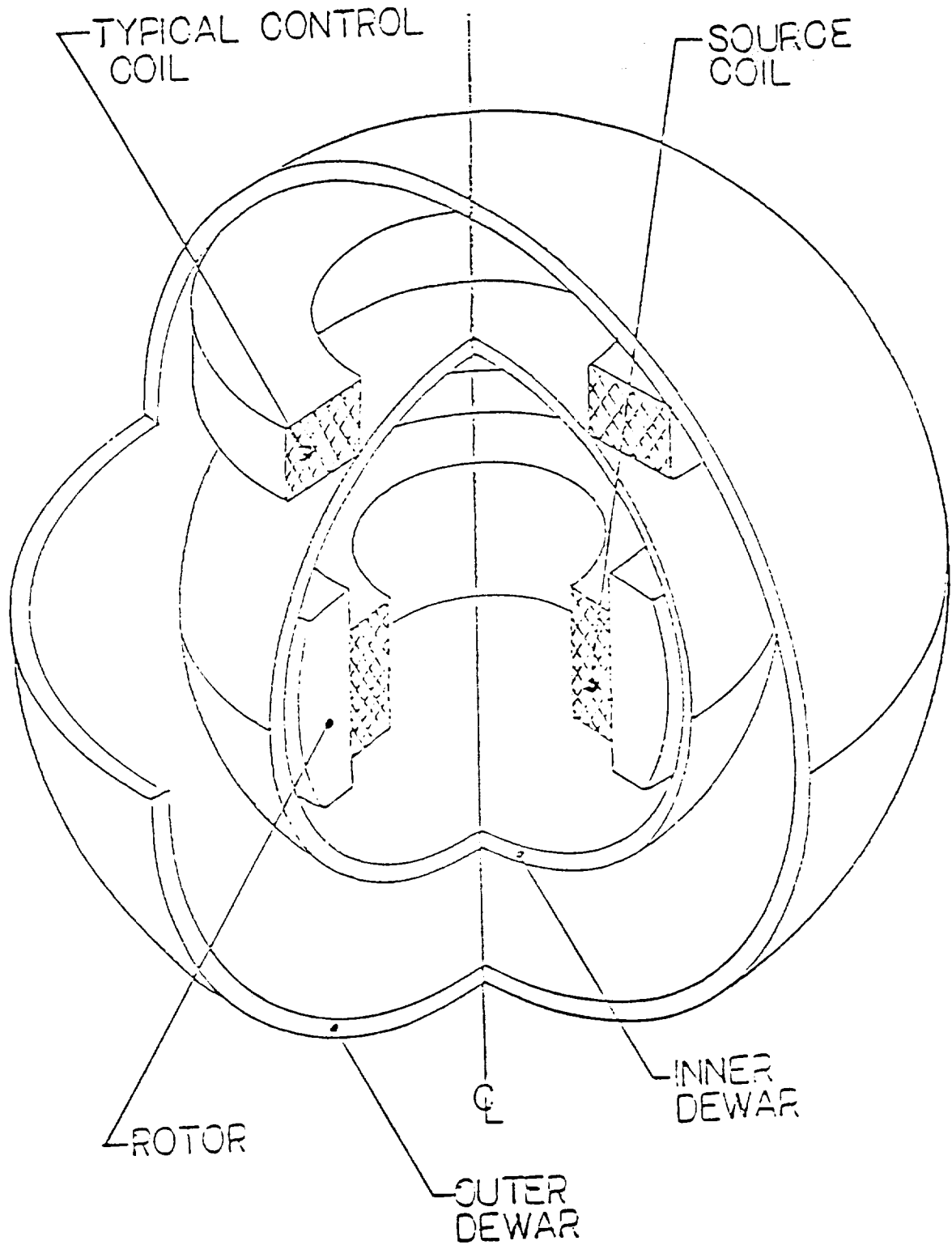

Figure 2. Advanced Slew Actuator

ORIGINAL PAGE IS
OF POOR QUALITY

An emerging technology, high purity aluminum conductors cooled to the boiling point temperature of liquid hydrogen, was found to be the best choice for the control coils. These "hyperconductors" allowed substantial improvements in mass and power consumption over what is obtainable through the use of copper conductors.

Table 1 contains the performance parameters (mass tabulation and power consumption) for the key components of the superconducting LAMS. These represent a vast improvement over what could be achieved with more conventional technology.

Table 1. Superconducting LAMS Performance

Control Torque	13,500 Nm
<u>Mass Tabulation</u>	
Control Coils	65 kg
Dewar	<u>57 kg</u>
Stator Total	122 kg
Source Coil	<u>57 kg</u>
LAMS total	179 kg
Power	57 W

3. TESTBED OVERVIEW

This section presents an overview of the prototype LAMS system. The description is arbitrarily divided into separate descriptions of the mechanical design, the magnetics design, the controller design, the sensor system design, and the electronics design.

Mechanical Design

The configuration of the testbed allows the LAMS to be operated as it would be in an actual CMG application (an array of twelve control coils) while maintaining the capability of a better demonstration with an array of six control coils. Each of the coils will be sized such that six of them can support the weight of the superconductor and dewar.

The system configuration drawing (Figure 3) shows three views of the hardware. The superconducting magnet and its dewar are shown in a horizontal attitude suspended by the control coils. The top view shows the upper six coils when twelve control coils are used for suspension. The front and side views show the base structure which supports the control coil. These front and side views show the superconductor and dewar suspended by six and twelve coils respectively.

The coils are supported by a pair of 300-series (non-magnetic) stainless steel weldments which form a dodecahedron. Six pentagon-shaped 0.090" sheets, each with a central hole, are welded at their edges to form the two separable halves of the dodecahedron. The two halves are joined by captive threaded fasteners and can be readily separated for either maintenance or reconfiguration purposes. The coil support sets on a separate base which is also 300-series stainless. It is formed from two rings connected by welded gussets to provide good stiffness.

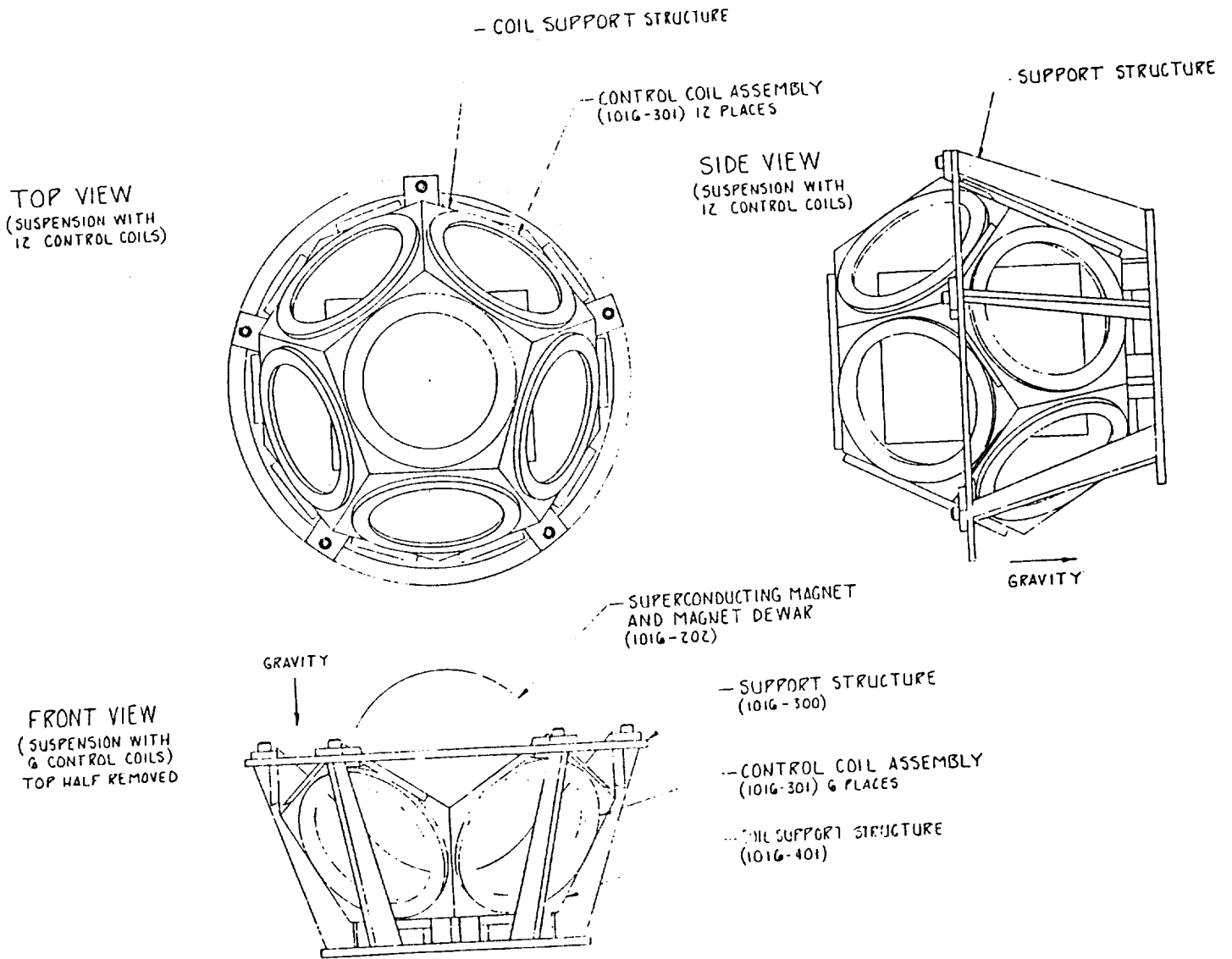

Figure 3. System Configuration

Superconducting Magnet and Cryostat Design

The superconducting solenoid is surrounded by a helium bath enclosed in a dual chamber vacuum dewar. The magnet is charged by means of removable current leads penetrating the dewar from the bottom through a thermally baffled stack. In a similar manner, liquid helium is filled through an inverted port. This port is normally sealed at its top. It utilizes a thin layer of helium gas for minimizing heat loss down the neck. The addition of an aluminum shield surrounding the aids in thermally tying the coil to liquid helium temperature thereby allowing operation at liquid levels well below the coil height and at full coil pitch.

The cryogenic system is illustrated in Figure 4. The coil is centered within the spherical cover and is supported by brackets attached to the base of the inner shell. The cryostat consists of three shells of domed metal welded to cylindrical side supports which are welded to their respective bases. The three penetrations into the helium bath provide access for power leads, helium filling, and diagnostics and persistent switch.

Several features of the design are directed toward allowing $\pm 60^\circ$ pitch of the magnetic axis without excessive loss of helium due to either pouring or increased heat loss to the vessel or feedthrus. In order to increase thermal tying of the coil to the 4° K thermal sink, the high thermal conductivity of aluminum is employed both in the fabrication of the inside shell of the dewar and by the addition of an additional shell bolted to the base which surrounds the coil. This arrangement helps to "pin" the temperature of the coil at 4° K even when the coil is not bathed in liquid. In this way, we will be able to operate the coil in the persistent mode with only enough liquid to wet the base of the inner dewar. To minimize thermal conduction through the coil input leads from the power lead stack, the leads will be guided away from the dewar wall and thermally connected to the base of the inner dewar before connection to the coil.

The three walled dewar assembly consists of two inner sections of 0.06" aluminum cylinders welded to the respective domes and bases and another section of stainless steel. The vacuum of both sections is common with the vacuum in both the power lead and helium fill ports. Each compartment is rigidly connected to the other by fiberglass cylinders attached to the grooved rings which join each dome to its respective cylinder. The space between the chambers is also filled with superinsulation to minimize radiation loss. The middle partition is thermally connected to the outer wall of the power lead port and should float near 100° K.

The power lead port is surrounded by single section vacuum dewar to minimize heat load into the helium bath from lead chamber which itself is cooled by venting helium gas. The inside wall is of stainless to minimize thermal conduction to the outside cap and is fitted with bellows to accommodate linear thermal expansion. The bayonet shaped conductors at the top of the assembly connect to the superconducting coil input leads.

In order to minimize liquid sloshing into the port, venting is from the top center of the helium vessel via tubes to the lead ports. The quench disc provides high throughput release in case of a magnet quench. The low pressure relief valve (~ 1 psi) prevents slow buildup of boiloff gas.

Controller Design

The controller design is aimed towards designing a controller which is robust to small plant changes (micro variations) and accommodating to gross plant variations (macro variations). The controller must take into account sensor characteristics as well as plant and model uncertainties.

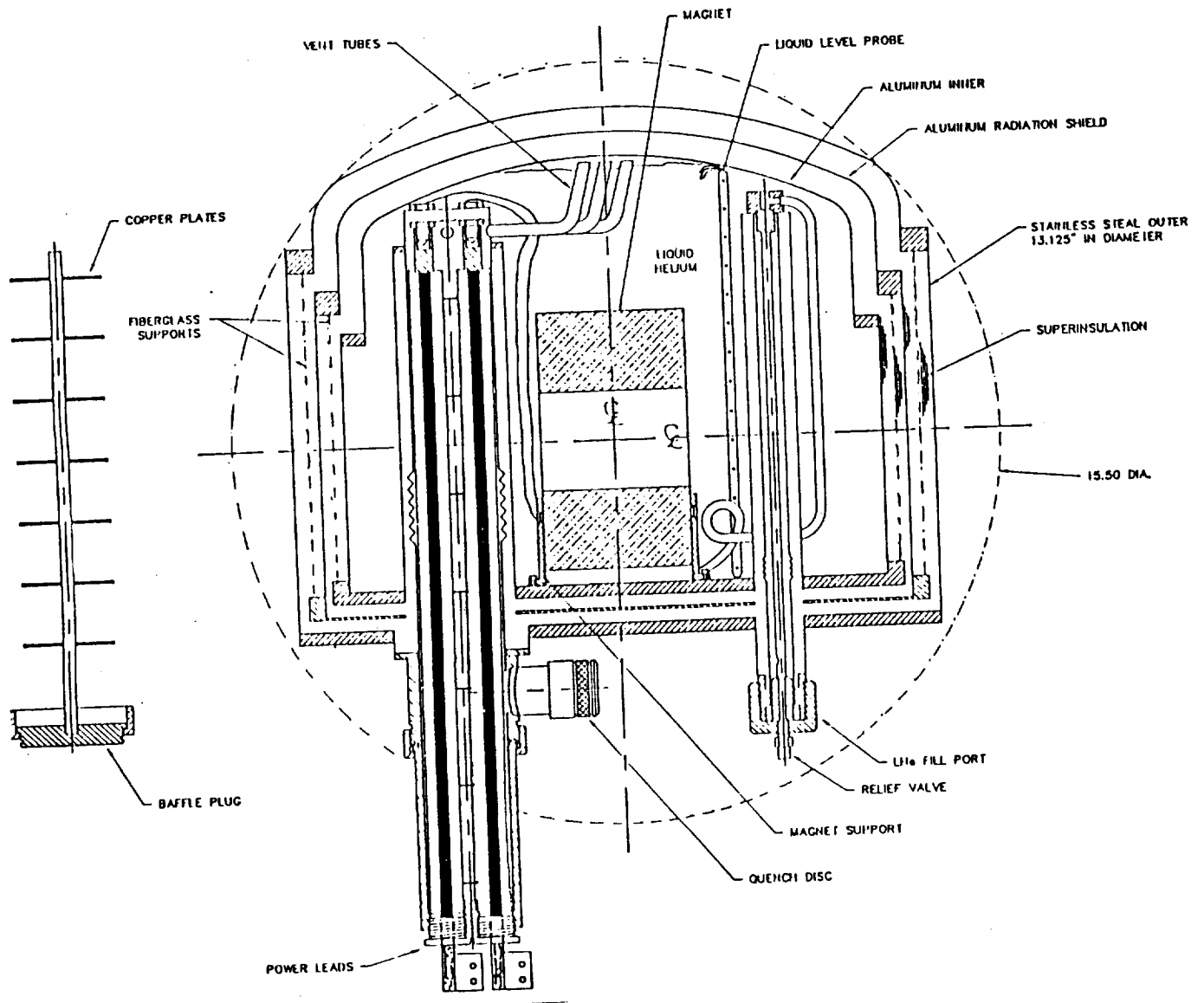

Figure 4. Magnet and Cryostat Design, Elevation View

ORIGINAL PAGE IS
OF POOR QUALITY

The LAMS shows large variations in the stiffness and control coefficients as a function of the superconducting coil orientation. Two reference frames referred to here as the fixed and the local coordinate frames are shown in Figure 5. The plant variations are periodic, sinusoidal in nature, and predictable if the orientation (Θ and ϕ) are known. Normally controllers for plants with large parameter variations are difficult to design. The controller concept as shown in Figures 6, 7, and 8 takes advantage of the predictable nature of the variations to arrive at an elegant control scheme.

The control of the superconducting coil is considered in stages:

- (i) a servo/command-following control of the orientation of the superconducting coil in the fixed reference frame as described by the Euler angles Θ and ϕ .
- (ii) the regulation of the position of the superconducting coil in the local reference frame $X'Y'Z'$ such that the coil axis orientation remains invariant.

The servo control rotates the superconducting coil to some desired orientation (Θ_{des} and ϕ_{des}). The displacements ($\Delta x'$, $\Delta y'$, $\Delta z'$) are the displacements of the superconducting source coil center of mass from the origin of the $X'Y'Z'$ reference frame and ($\Delta\alpha'$, $\Delta\gamma'$) are the rotations of the superconducting coil around the X' and Y' axis. $\Delta x'$, $\Delta y'$, $\Delta z'$, $\Delta\alpha'$ and $\Delta\gamma'$ are regarded to be small variations around nominally zero values.

The controller is built around a fixed gain linear quadratic regulator (LQR) and a state estimator based on a fixed gain Kalman filter. The regulator (Figure 7) and the Kalman filter (Figure 8) are designed with reference to the local frame of reference $X'Y'Z'$. The Kalman filter takes into account the sensor characteristics to arrive at an optimal estimate of the states, essentially ($\Delta x'$, $\Delta y'$, $\Delta z'$, $\Delta\alpha'$, $\Delta\gamma'$) and respective velocities, of the superconducting coil. The states are regulated to zero by the LQ regulator using the state estimates generated by the Kalman filter. The transformation (Γ) relating the $X'Y'Z'$ frame to the XYZ frame (and the inverse) form the "interface" between the orientation measurements made in the fixed reference frame, the LQ regulator and the control coils providing the regulation forces.

In this scheme only the transformations are dependent on the orientation angles (Θ and ϕ). The plant uncertainties are accommodated in the LQ regulator design. The deviations of the controller performance are bounded by the maximum bounds on the plant modelling errors and plant variations.

The controller implementation will be using a floating point DSP. The fixed gain LQ regulator, the Kalman filter and the transformations will be executed in real time by the DSP. The transformations are the most computationally intensive part of the controller implementation.

Sensor System Design

The sensor system consists of a three-degree-of-freedom translation sensing system and a two-degree-of-freedom rotation sensing system. The design of the system is illustrated in Figure 9.

Translational Sensors

The three degrees of translation will be sensed by capacitive devices operating at about 1 kHz. These devices are inherently simple, impose minimal constraints on the spherical surface, are insensitive to ambient magnetic fields, and require only a target smoothness less than the desired resolution.

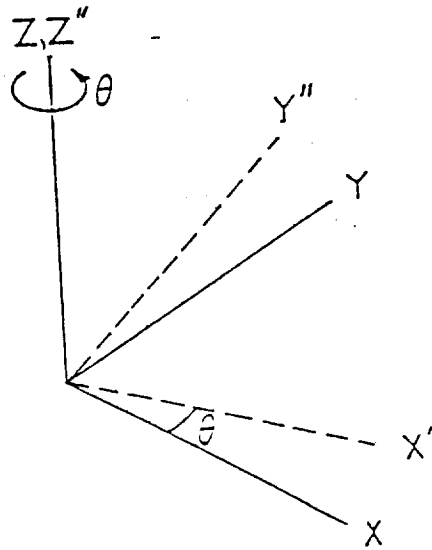

θ rotation around the Z axis to give the intermediate axis X'', Y'', Z'' . Z and Z'' remain coincident.

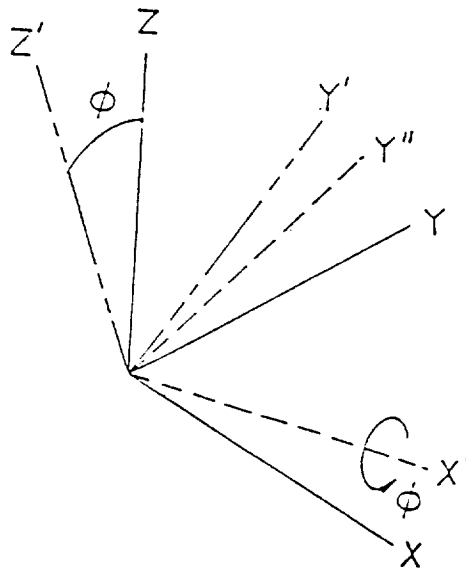

ϕ rotation around the X'' axis to give the axis X', Y', Z' . X'' and X' remain coincident.

Figure 5. Euler Angles

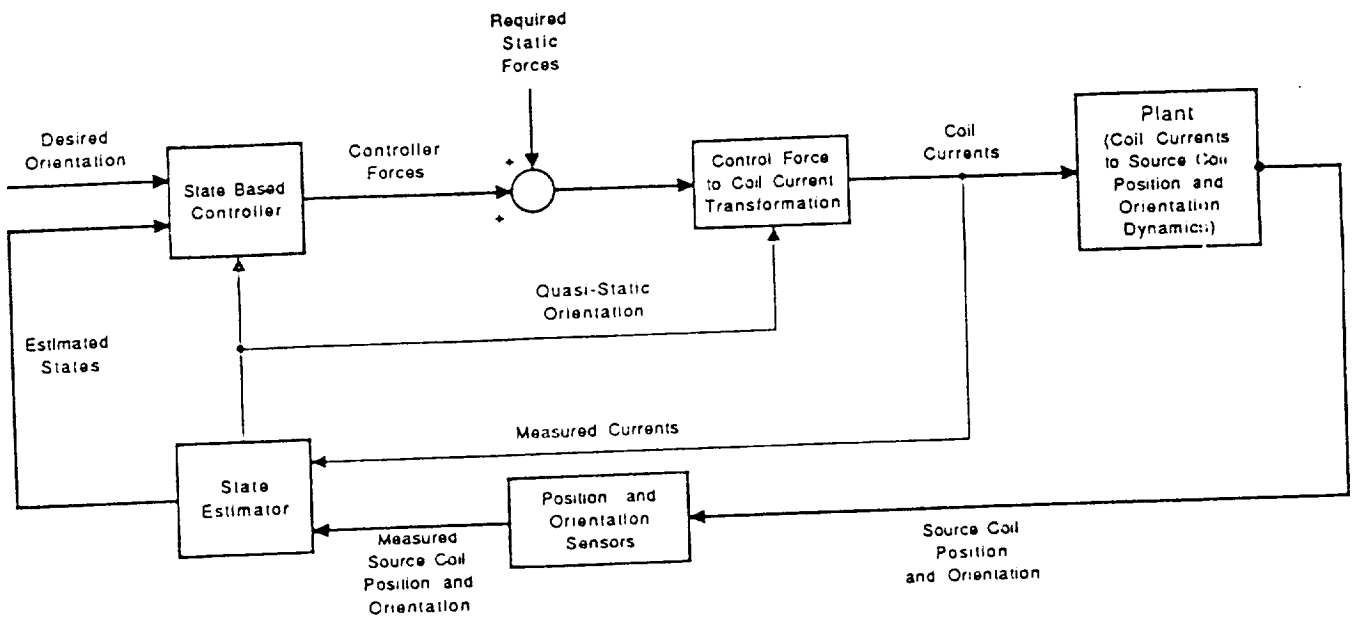

Figure 6. Controller Architecture

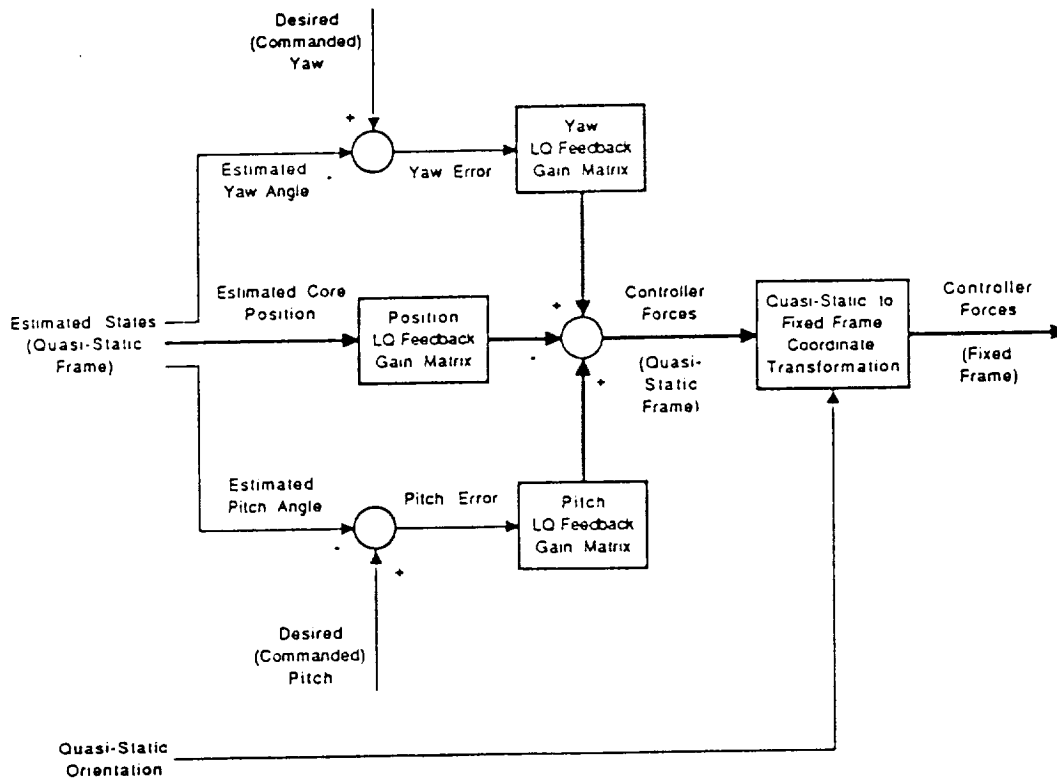

Figure 7. Regulator Architecture

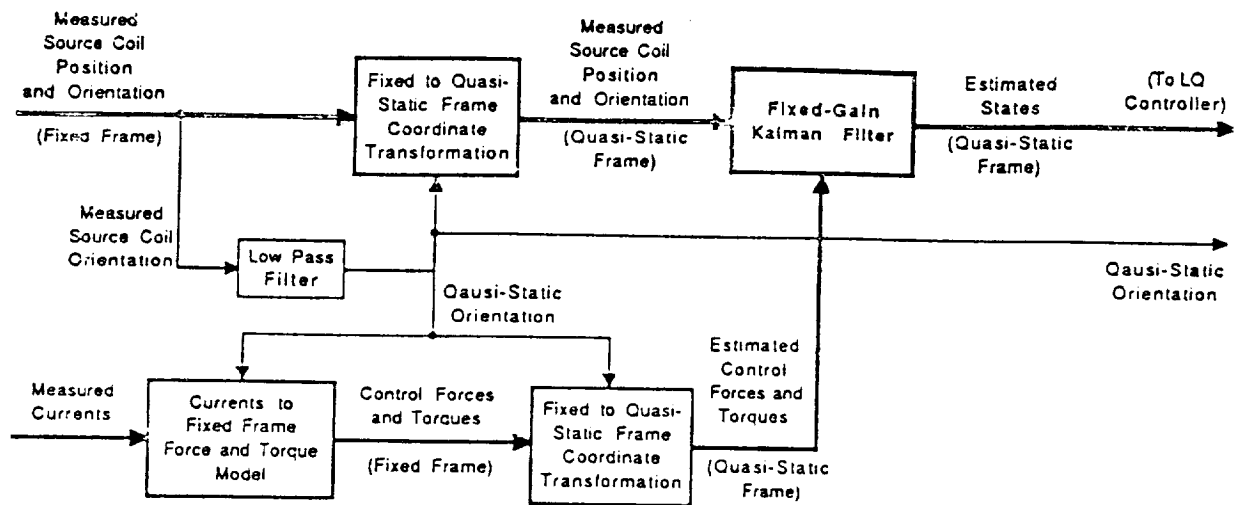

Figure 8. Kalman Filter

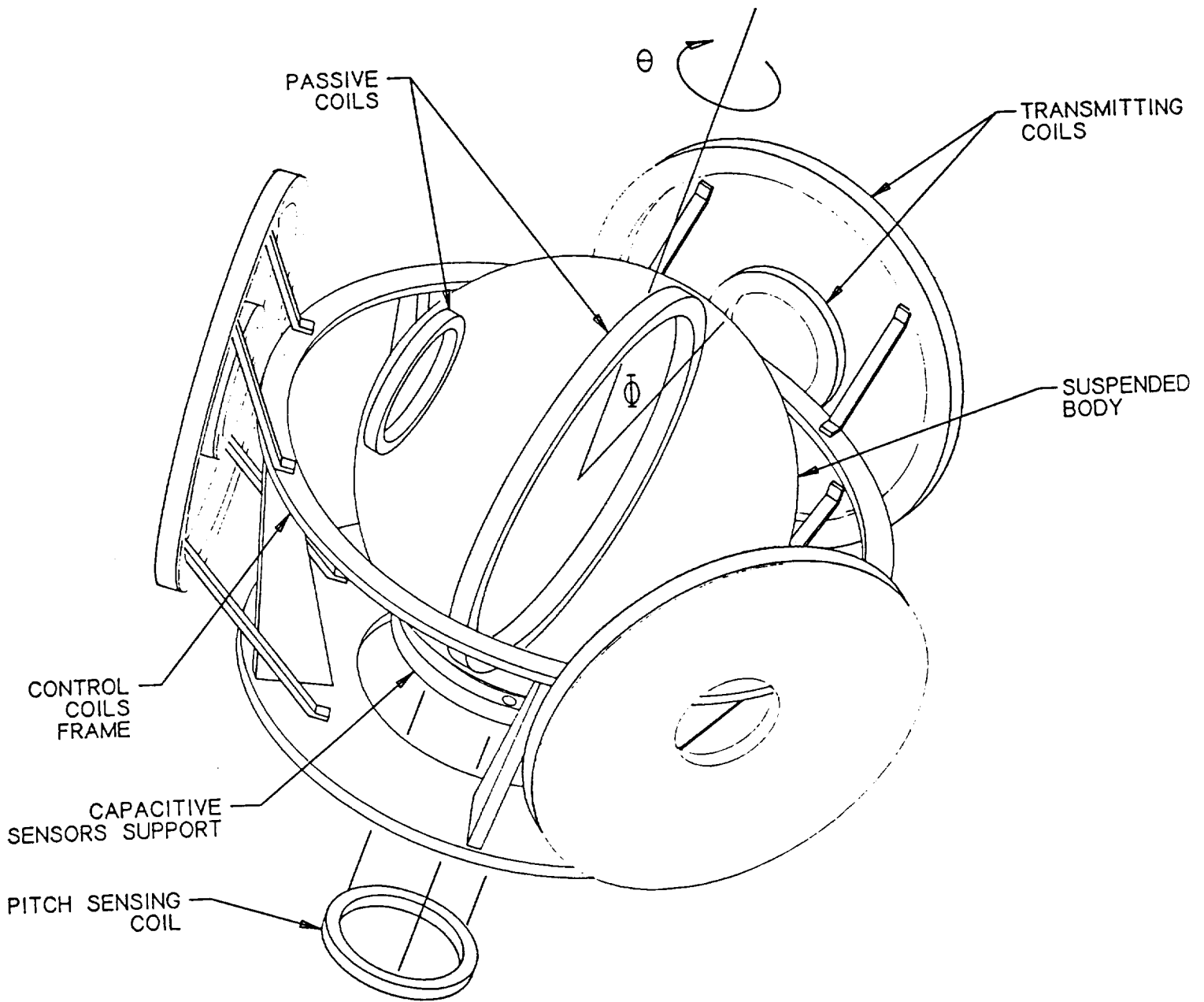

Figure 9. Position Sensing System

Rotation Sensing

The two rotational angles will be determined from the mutual inductance between a set of stationary transmitting coils placed outside the control coil set and two passive coils moving with the cryostat/magnet. Both the transmitters and moving coils will employ series capacitors which will cancel inductance terms thereby enhancing sensitivity. The control coil set which are well coupled to the transmitters will be fitted with band trapping filters designed to present a high impedance to induced voltages.

Three transmitters arranged at 120° intervals will determine both the angle of rotation in the horizontal plane, Φ , and Θ , the pitch angle around the horizontal plane, by measuring the coupling to a coaxially-mounted polar coil in the sphere. The inherent rotational degeneracy will be resolved by a second sensing coil placed at the spherical "surface" in conjunction with four additional external transmitting coils operating at a different frequency.

The mechanical arrangement of the coils is illustrated in Figure 9. As implemented here, mutual inductance sensing involves exciting outside static coils with a fixed current then coupling this energy into passive coils on the rotating body at a frequency well above the minimum response rates required for the control system. The power coupled into the cryostat of the superconducting magnet must not cause excessive helium loss while induction in the control coil set must not interfere with proper operation.

Both the transmitting primary and passive secondary coil self-inductances are made resonant with series-placed capacitors. The change in mutual inductance (calculated from the coil voltage driven with a constant current) is then used to track rotation. The effective circuit is shown in Figure 10.

The baseline design will utilize two passive coils of 10 to 30 turns with capacitive shunts on the sphere. The large coil will be resonant at 50 kHz, the smaller at 38 kHz. The fixed set will consist of seven coils of two sizes. Each large coil will be resonant at 50 kHz and be driven with a constant current oscillator. The voltage across each coil will be filtered, demodulated, and routed to the DSP for use by the control coil amplifiers. The small coils will be resonant at 38 kHz and be connected in the same way.

Electronics Design

The LAMS system electronics interfaces between the position sensors and the control coils to implement the algorithm required for proper five degrees-of-freedom control. This section specifies the baseline design of these electronics.

Current technology allows several alternative component choices for implementing digital controllers. The digital signal processor (DSP) is the most recent and most advanced of the digital technologies featuring high-speed processing due both to its higher clock frequency and to the use of an internal hardware multiplier. In addition, the data and address interfaces are structured for rapid data handling.

Figure 11 shows the block diagram of the baseline control electronics with a DSP at its core. Five sample-and-holds (S/H) are used on the five analog position signals to ensure data simultaneity. The analog multiplexer (MPX) sequentially feeds the values to the analog-to-digital-converter (A/D) for processing and subsequent inputting to the DSP. The DSP requires both read-only memory (ROM) for program storage, and random-access memory (RAM) for data storage. Six digital-to-analog converters (D/A) are used to output the command voltages, each with its own data latch to hold the latest output value. The D/A's directly drive the switching power amplifiers which produce the command currents in the control coils, thereby completing the feedback path.

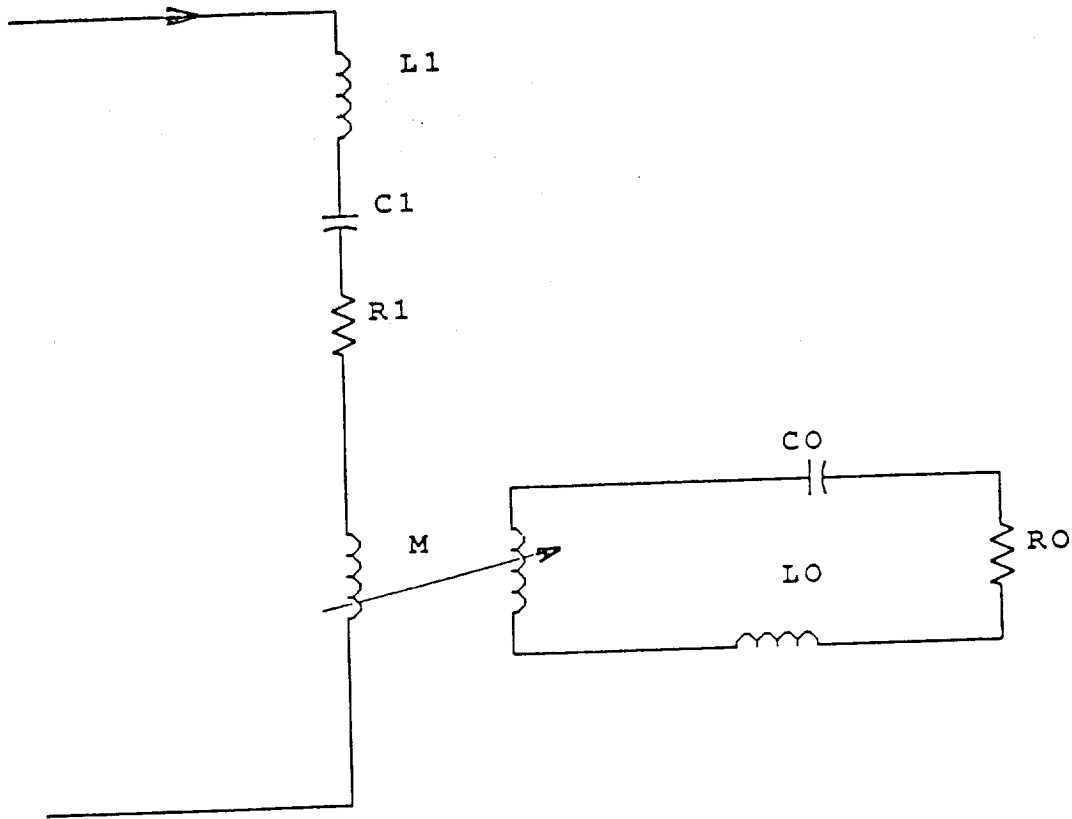

M is mutual inductance between coils; rotating coil components denoted by '0,' excited coil by '1.'

Figure 10. Single Coil Sensing Circuit

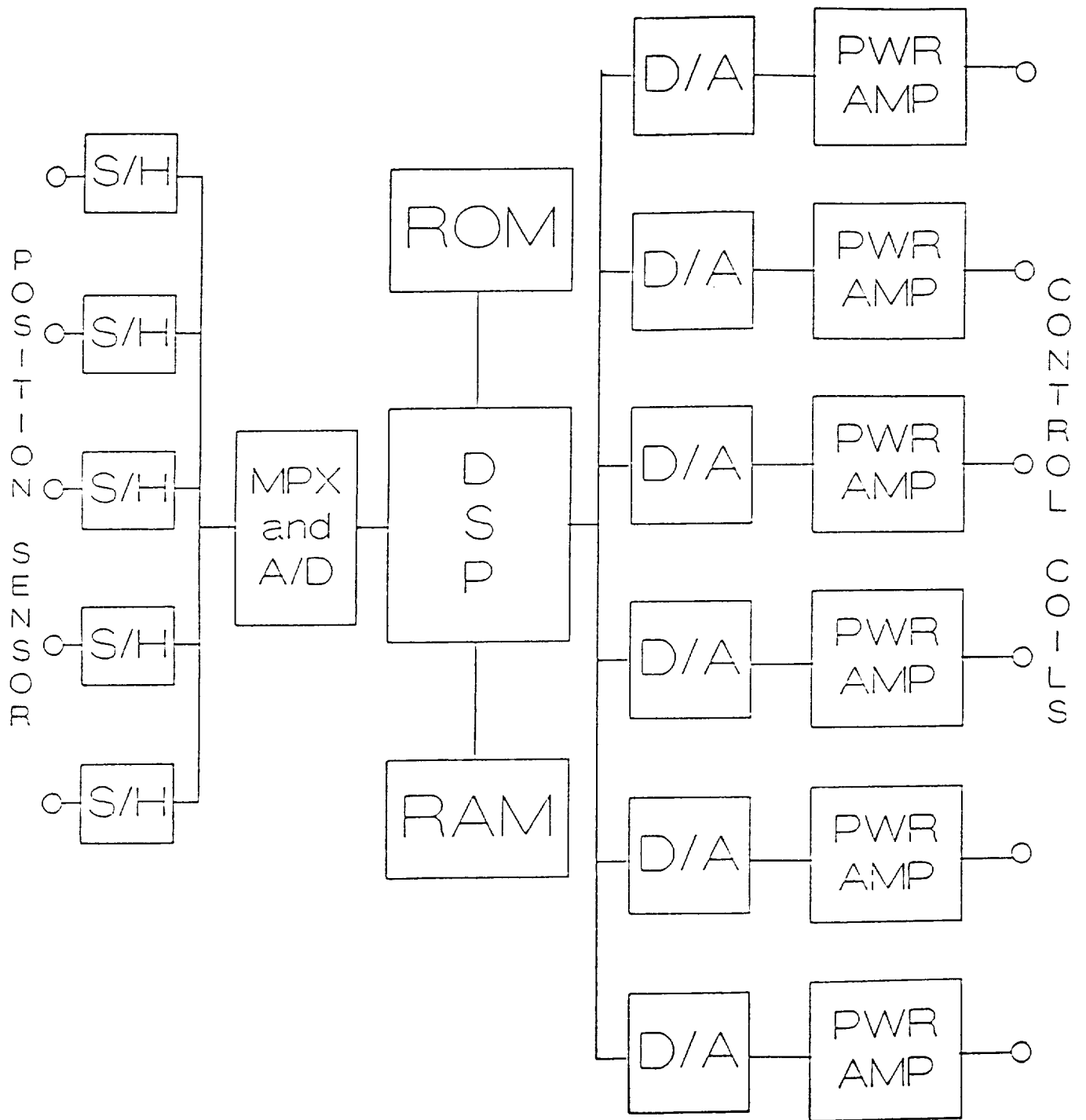

Figure 11. Electronics Block Diagram

4. CONCLUSION

This paper has described the design of a prototype for an innovative type of superconducting magnetic suspension system. This control system demonstration experiment which is currently being constructed will provide a significant milestone in the overall development program.

REFERENCES

1. J. Downer, D. Eisenhaure, R. Hockney, B. Johnson, and S. O'Dea, "Magnetic Suspension Design Options for Satellite Attitude Control and Energy Storage," Proceedings of the 20th Intersociety Energy Conversion Engineering Conference, pp. 2.424-430.
2. J. Downer, Design of Large-angle Magnetic Suspensions, ScD Thesis, Massachusetts Institute of Technology, May 1986.
3. J. Downer, D. Eisenhaure, R. Hockney, and B. Johnson, "Application of Magnetic Bearings to High-Torque, Satellite Attitude Control Wheels," 22nd Intersociety Energy Conversion Engineering Conference, Philadelphia, PA, August 1987.