

04

N91-21204

NONLINEAR COMPENSATION TECHNIQUES for MAGNETIC SUSPENSION SYSTEMS

David L. Trumper
University of North Carolina at Charlotte
Department of Electrical Engineering
Charlotte
NC 28223

Nonlinear Compensation Techniques for Magnetic Suspension Systems

David L. Trumper
Dept. of Electrical Engineering
Univ. of N. Carolina at Charlotte
Charlotte, NC 28223

1 Introduction

In aerospace applications, magnetic suspension systems may be required to operate over large variations in air-gap. Thus the nonlinearities inherent in most types of suspensions will have a significant effect. Specifically, large variations in operating point may make it difficult to design a linear controller which gives satisfactory stability and performance over a large range of operating points.

One way to address this problem is through the use of nonlinear compensation techniques such as feedback linearization. In the last decade, this area has seen a great deal of research effort among system theorists [6], [7], [8], and has been successfully used in flight control applications [9], but has yet to be widely used in the area of magnetic suspensions.

Nonlinear compensators have received limited attention in the magnetic suspension literature. In [11] the control system design for suspension of a 1-ton, 4-passenger vehicle is presented. A flux sensor is located on the pole-face of the suspension magnet. A minor feedback loop is closed on flux which linearizes the dependence of magnetic force on position. The force goes as the square of flux, so an additional square root linearization is required. The idea of using an analog multiplier to compute the ratio i/x is mentioned, which would allow elimination of the flux sensor. However, this technique is reported as prone to drift and noise, and was abandoned. This flux-feedback scheme is described in more detail in [12]. In [13] a nonlinear correction law is used to correct the inverse square law magnet behavior in a flywheel suspension. The nonlinear compensation is implemented with analog multiplier and square root circuits. Microprocessor-based linearizing transformations are reported in [14] in the context of a demonstration system.

In recent years, progress has been made in the theory of nonlinear control systems, and in the sub-area of feedback linearization. Here, [6] is of fundamental importance in that it presents the conditions under which a system may be linearized. In [7] these results are globally extended, and in [8] the theory is developed for multi-input/multi-output systems. In a subsequent section the results of [6] are applied to a third order suspension example. However, for a simple system, it is often possible to construct the linearizing transformations by inspection. We start then by demonstrating the idea of feedback linearization using a second order suspension system. In the context of the second order suspension, sampling rate issues in the implementation of feedback linearization are examined through simulation. The system which is studied is presented in the next section.

2 Nonlinear Suspension Model

In this section, the open-loop dynamics for a simple one-degree-of-freedom suspension are presented. This system exhibits the essential issues faced in the design of tractive type suspensions, that is, suspensions which operate as variable reluctance devices. The example is drawn from [10] pgs. 22-23, 84-86, and 193-200. The only change is that the system is inverted such that gravity acts to open the air-gap. This system is shown in Figure 1.

The details of the electromagnetics are worked out in [10]; for the present purposes, the important details are the coil voltage

$$v_c = \frac{2wd\mu_0 N^2}{g_0 + x} \frac{di}{dt} - \frac{2wd\mu_0 N^2 i}{(g_0 + x)^2} \frac{dx}{dt} + iR \quad (1)$$

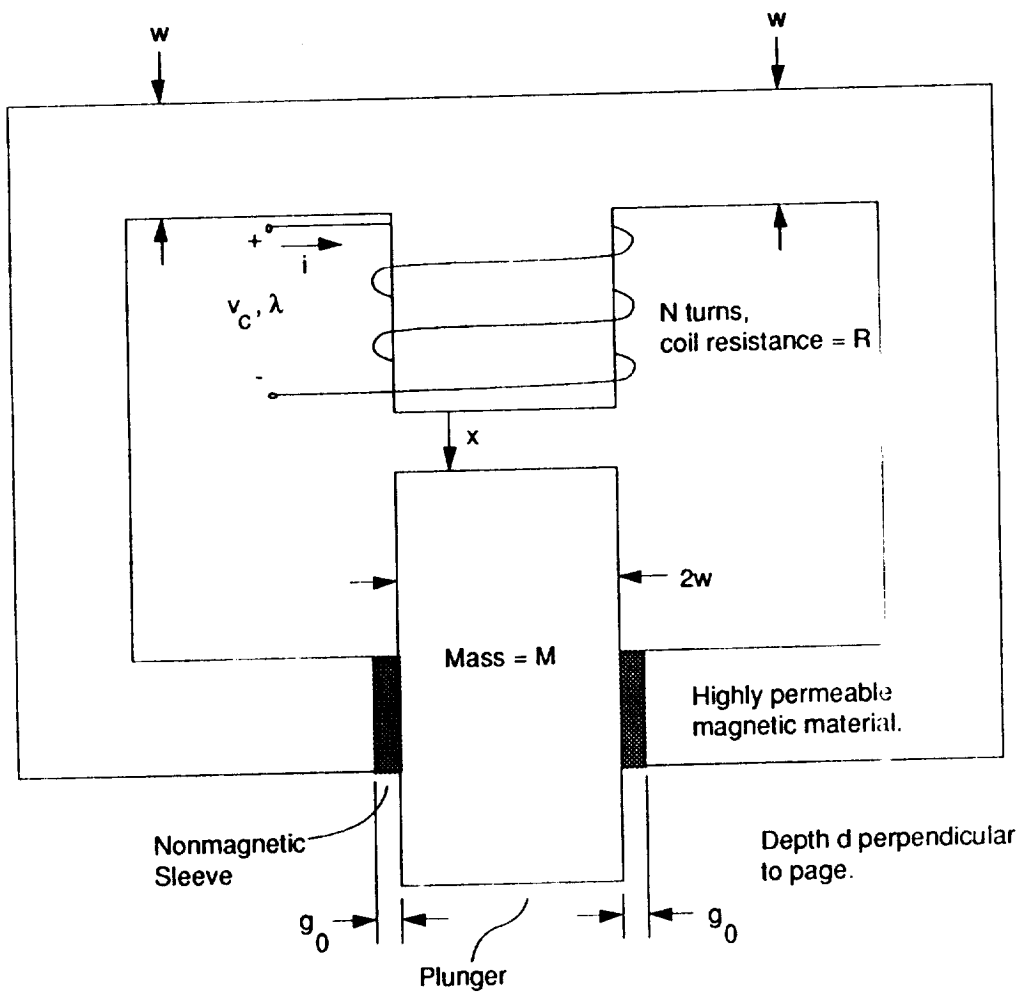

Figure 1: Single degree of freedom suspension.

and the force on the plunger

$$f_x = -wd\mu_0 N^2 \left(\frac{i}{g_0 + x} \right)^2 + Mg - f_d, \quad (x > 0) \quad (2)$$

where the first term is the electromagnet force, the second term is the gravitational force on the plunger, and the third term is a disturbance force acting on the plunger in the direction the electromagnet force. The nonmagnetic sleeve is assumed to exert no frictional forces on the plunger.

If we define

$$\begin{aligned} u &= v_c \\ C &= wd\mu_0 N^2 \\ x_1 &= x + g_0, \quad (x_1 > g_0) \\ \dot{x}_1 &= x_2 \end{aligned}$$

then the state equations for the open-loop suspension are

$$\begin{aligned} \dot{x}_1 &= x_2 \\ \dot{x}_2 &= -\frac{C}{M} \left(\frac{i}{x_1} \right)^2 + g - \frac{f_d}{M} \\ \dot{i} &= \frac{ix_2}{x_1} - \frac{Rix_1 i}{2C} + \frac{x_1 u}{2C}. \end{aligned} \quad (3)$$

2.1 Second order system

If the coil current is assumed to be the control input, then the suspension state equations are reduced to second order.

$$\begin{aligned} \dot{x}_1 &= x_2 \\ \dot{x}_2 &= -\frac{C}{M} \left(\frac{i}{x_1} \right)^2 + g - \frac{f_d}{M} \end{aligned} \quad (4)$$

These equations will adequately model the system if the coil current is controlled by a high-bandwidth current loop with sufficiently high voltage-drive capabilities. In applications, it is most typical to drive the coil with such a current loop, as this essentially eliminates the dependence of position-loop performance upon the electromagnet coil resistance and inductance.

3 Linearization of second-order suspension

The basic idea of feedback linearization is to define transformations on the states and input(s) such that the nonlinear system appears linear and operating-point invariant in terms of the transformed representation. Then a controller can be designed for the transformed variables. This allows the closed-loop system stability to be made independent of operating point.

For the second-order equations (4), a transformation on the input is all that is required to linearize the system. This transformation may be derived by inspection without using any formal mathematical machinery; this is the approach taken in [11], [12], [13], and [14]. That is, if the coil current i is made to vary as

$$i = x_1 \sqrt{\frac{-vM}{C}} \quad (5)$$

then the suspension is globally linearized in terms of the new input v . The notation for the auxiliary input v has been chosen to match the notation in [6].

Specifically, substituting from (5) into (4), the system state equations become

$$\begin{aligned} \dot{x}_1 &= x_2 \\ \dot{x}_2 &= v + g - \frac{f_d}{M} \end{aligned} \quad (6)$$

These equations are linear, with an input v , and disturbance terms g and f_d .

Here, v is a signal internal to the compensator which may be thought of as a setpoint for acceleration in the direction of increasing airgap. In operation, the signal v will be computed within the compensator, and constrained to be less than or equal to zero. Since the magnet can only supply accelerations in the direction of decreasing air gap it would not be physically meaningful to ask for acceleration in the direction of *increasing* air gap by setting v greater than zero. Thus the term $-v$ in (5) will always be greater than or equal to zero, and the square root will yield a real number.

The plant appears linear in terms of the new input v . This compensation of the nonlinear term does not however stabilize the plant. To stabilize the system, the nonlinear compensator is preceded by a linear compensator. The resulting closed-loop system is shown in Figure 2. The compensator may be thought of as having two parts, a nonlinear compensation section and a linear compensation section. It is the function of the nonlinear section to implement (5) in order to adjust i as a function of x_1 and v , such that the acceleration of the plunger is equal to v . It is the function of the linear section to specify the value of v as a function of the error between the position setpoint and the measured position such that the linearized plant is robustly stabilized and has good disturbance rejection and settling time properties. The signal v forms the connection between the linear and nonlinear sections of the compensator.

This combination of linear and nonlinear compensation sections stabilizes the plant such that the loop dynamics are independent of operating point. Such operating point independence is the main advantage of using a nonlinear compensator. Note that as viewed from the input to the nonlinear section, the incremental relationship between v and x_1 is equal to $1/s^2$, independent of operating point. Thus, the linear compensator can be designed to control a double integrator via standard linear techniques. If it is desirable to reject static disturbance forces with no position error, then the linear compensator can be designed to include an integral term. This integral term will adjust the value of v to balance gravity and any low-frequency components of the disturbance f_d .

In applications where large excursions or disturbance forces are anticipated, the additional complexity of the nonlinear compensation approach is justified. The major caveat is that we are assuming that the suspension model is accurate. For the electromagnetics an accurate model can readily be developed, and thus nonlinear compensation techniques are applicable. The nonlinear compensation technique was used in the construction of a class demonstration system which is described below.

4 Classroom demonstration implementing linearization

In the Spring of 1988, the author constructed a single degree of freedom levitation system for use as a classroom demonstration which implemented the nonlinear compensation technique described in the previous section. As developed there, if the plant state equations are given by (4), then applying the nonlinear compensation law (5) results in a system which appears to be linear in terms of the intermediate signal v . The demonstration system uses a high-bandwidth current-drive to regulate the electromagnet current, and thus (4) is applicable.

In the demonstration system, a one inch steel ball bearing is suspended below an electromagnet consisting of 3100 turns of #22 magnet wire wound on an 1 inch diameter by 4 inch length steel core. The coil current is controlled by a Bose-type switching regulator, with a half-scale current switching frequency of 10 kHz, and a full scale current of 2 Amperes. The operating point current is about 0.4 Amperes at a typical operating point air gap of 1 cm. The system is digitally controlled by an 8088/8087-based single-board computer and data acquisition system at a 400 Hz sampling rate. The control law for the nonlinear compensation section uses (5) to linearize the magnetic force relationship. This allows the stability of the closed-loop system to be essentially independent of the operating point. The control law for the linear compensation section is then developed via classical techniques applied in the discrete-time domain. The position of the ball is sensed optically, and nonlinearities in the sensor output versus position are compensated for in software.

In order to apply the nonlinear compensation technique, an accurate model of the plant is required. For the classroom demonstration, this model is developed by measuring the force on the ball as a function of current and position. This measurement is accomplished by using a balance beam for measuring the magnetic force on the ball. A 1 inch ball bearing is glued into one end of an aluminum balance beam of rectangular tubular cross-section measuring 1 inch wide by 0.75 inches deep by 12 inches long. The

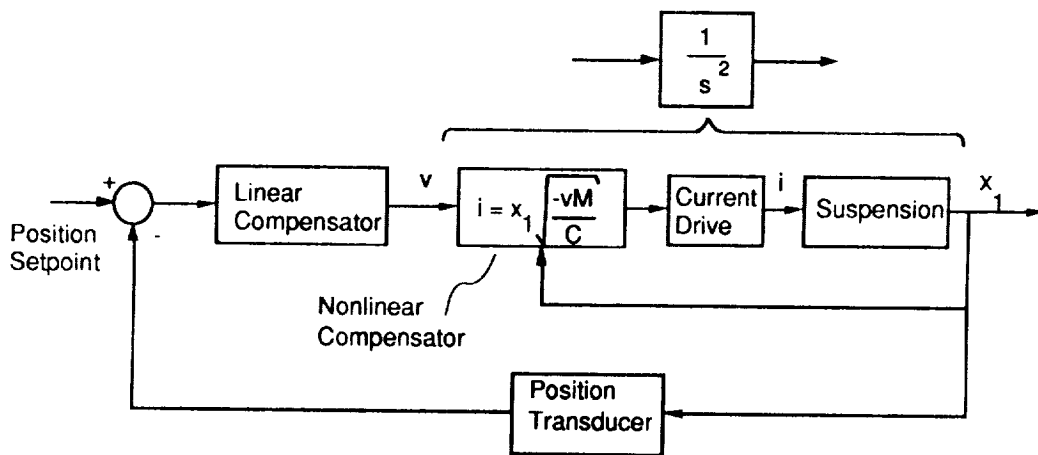

Figure 2: Nonlinear compensation of second-order magnetic suspension system.

beam pivots at the center on a thin wire which is held by fixed side supports. Balance pans are hung from the beam on both sides of the pivot midway between the pivot and the ends of the beam. These pans are used to add or subtract weight carried by the suspension. At the end of the beam opposite the ball, a micrometer is positioned to push against the beam and thus provide a position reference.

The idea here is that the ball glued into the end of the beam can be placed into suspension and the beam thus provides a handle by which the force applied to the ball can be varied. This is accomplished by putting weights into the balance pans on either side of the pivot. The beam is made of aluminum, and thus does not interact with the electromagnet at low frequencies. At the ball end, the beam is made thin so as not to interfere with the optical measurement. The ball is attached to the bottom of the thinned end of the beam such that it interacts with the optical sensor in the same fashion as a freely suspended ball.

The force relationship (2) was well fit by the experimental data with the parameters $C = 4.43 \times 10^{-4} \text{ Nm}^2/\text{A}^2$ and $g_0 = 0.25\text{cm}$. The mass of the ball is 67 grams. These parameters are used in the nonlinear compensation law (5). The only deviation from the relationship (2) is at high currents ($> 1\text{A}$), where the effects of magnetic saturation are apparent.

The optical position sensor is constructed as follows. A 24 volt, 5 watt incandescent lamp is used as the source, and a piece of cadmium sulfide photo-cell is used as the sensor, in what is a standard position sensor for magnetic suspensions. Using the balance beam described above, the sensor output is measured for a number of ball positions. When the shadow-line cast on the sensor is in the central region of the sensor, the sensor output is essentially linear with ball position. However, as the shadow-line approaches the upper or lower edge of the photo-cell, the sensor sensitivity begins to decrease. This nonlinearity in the relation between ball position and sensor output is corrected in software in the section of code which inputs the sensor voltage. The corrected position measurement is then linear with actual ball position. It is this corrected position measurement which is passed to the rest of the control loop.

The position sensor was found to have several defects which limit the system performance. First, the incandescent bulb output decreases significantly as a function of time. This is believed to be due to the evaporation of the filament. Material driven off of the filament is deposited on the inside of the glass envelope, thereby decreasing the bulb brightness. The second problem is that the cadmium sulfide sensor is sensitive to any light falling on its surface, independent of the source. Thus ambient lighting is indistinguishable from the light emitted by the bulb.

Both of these effects cause problems in the nonlinear compensation law (5) and in the correction of the sensor nonlinearities. First, the decrease in bulb intensity and any changes in average ambient light act as offset terms which drive the system to incorrect points on the sensor correction curve and in the magnet nonlinearity correction law (5). This offset deteriorates the system stability. Secondly, the ambient light has a large component at twice the power line frequency, especially in rooms with fluorescent lighting. This signal at 120 Hz acts as a large noise source which causes error motions in the ball position.

The above problems can be solved as follows. First, the light source needs to be made more constant with time. This can be achieved by using a more specialized incandescent bulb, or by switching to a semiconductor light source such as an infra-red light emitting diode. The ambient lighting offset and noise problems can be solved by either or both of two approaches which are classical. The first is to make the system narrow-band. Commonly available IR diodes emit a relatively narrow-band optical signal; laser diodes are narrower. In this case, an optical band-pass filter can be placed in front of the sensor, so that only the emitted frequencies are sensed, and the ambient lighting is greatly attenuated. The second approach is to switch the light-source on and off at a high frequency and use synchronous detection to reject signals which are not at the same frequency and phase as the source. The frequency of switching must be made much higher than the cross-over frequency of the position control loop, perhaps on the order of 10 kHz switching frequency. This rate is easily within the capabilities of available electronics.

The results derived in the previous section for the nonlinear compensation laws assume that these are implemented in continuous time. For discrete-time implementation, the issue of sampling rate becomes important. This issue is investigated in the next section.

4.1 Sampling rate issues

Due to the complexity of the transformations it is most likely that a linearizing compensator will be implemented in discrete time. As an introduction to one issue involved in discrete-time implementation, the effect of sampling rate on the second-order suspension system (4) is investigated by simulation. For this example, the suspension parameters have been given the values developed for the class demonstration system described above. These values are $M = 67$ grams, and $C = 4.43 \times 10^{-4}$ Nm²/Amp².

The system is simulated assuming a nonlinear compensation law of the form (5). The four graphs shown in Figure 3 indicate the system behavior when a net 0.05g acceleration ($v = -0.05$ in (5)) is specified. The lines labelled 'ideal' show that if the nonlinear compensation was perfectly implemented, the force on the ball would be constant, and the graph of velocity vs. time would be a straight line. However, with any finite sampling rate this is not the case. The system is open-loop unstable, and uncontrolled between sampling instants. Thus it 'runs away' during the interval in which the control current is held constant. The graphs show the result of this process for sampling rates of 1 kHz and 200 Hz. To get reasonable behavior, it can be seen that a sampling rate on the order of 1 kHz is required. In the class demo, due to computational speed limitations a 400 Hz sampling rate is used. This is found to be adequate as long as the ball is not allowed to approach too close to the pole face.

Another way to look at the effect of sampling rate is to examine the system behavior under closed-loop position control. To this end, a linear proportional plus lead compensator is designed in discrete-time to stabilize the nominal plant which would result if the nonlinear compensation were perfect. That is, in the ideal case, the nonlinear compensated system appears as a double integrator independent of operating point. In the finite sampling time implementation, the quality of this approximation deteriorates as the air gap closes. This can be seen in Figure 4 which displays simulated step responses for the closed-loop system at four nominal operating points and for the two sampling rates. Note that the system with 200 Hz sampling goes unstable at the 0.5 cm and smaller air gaps, whereas the behavior of the 1000 Hz sampled system only begins to deteriorate when the air gap approaches 0.3 cm. The unstable response for 200 Hz sampling is not shown for the 0.3 cm air gap.

This example shows that the practical implementation of linearizing transformations may require very high sampling rates. Also, what may be considered a satisfactory sampling rate depends on the range of operating points which are encountered in system operation. Certainly, the issue of discrete-time implementation merits further study.

Experience with this simple nonlinear compensation system provided the impetus toward an understanding of feedback linearization techniques in more generality. A description of the application of feedback linearization to the third order suspension system is given in the next section.

4.2 Linearization of third-order suspension

For more complex plants it may be difficult to develop linearizing transformations by inspection. The results of [6] provide a general approach to this problem. A good introduction to these ideas is presented in [4] and [5]. These references assume no more than an undergraduate background in control theory and are thus a good place to start for someone new to this area.

Without reviewing the results from the above references, if the plant satisfies a controllability condition and a condition on the existence of solutions to a set of partial differential equations, then transformations $z_1 = T_1(x), \dots, z_n = T_n(x), v = T_{n+1}(x, u)$ can be constructed such that in the z - v space the system appears linear. Here, x is the state-vector of the nonlinear system, z is the state-vector of the linearized system, and n is the system order. Under these transformations, the nonlinear system is mapped to the controllability canonical form

$$\frac{d}{dt} \begin{pmatrix} z_1 \\ \vdots \\ z_{n-1} \\ z_n \end{pmatrix} = \begin{pmatrix} z_2 \\ \vdots \\ z_n \\ 0 \end{pmatrix} + \begin{pmatrix} 0 \\ \vdots \\ 0 \\ 1 \end{pmatrix} v. \quad (7)$$

For the system (3), the required conditions are satisfied, and the results of [6] yield the linearizing transformations $z_1 = x_1$, $z_2 = x_2$, $z_3 = -(C/M)(i/x_1)^2$, and $z_4 = \frac{i}{Mx_1}(Ri - u)$. Thus the system

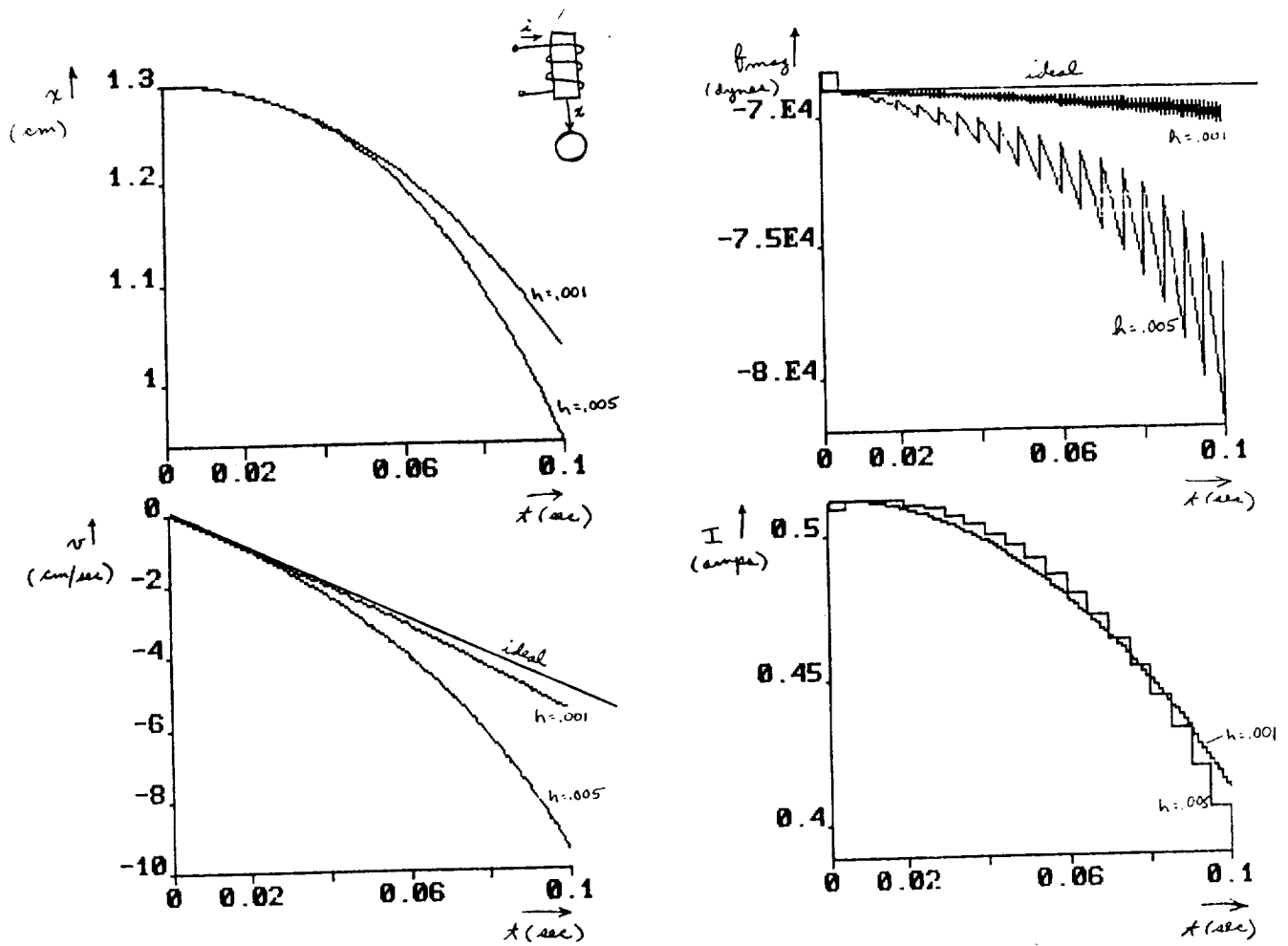

Figure 3: The open-loop system with nonlinear compensation showing its performance with sampling periods h of 1 and 5 milliseconds. Position x is in cm separation from the pole face, velocity v is in cm/sec, force on the ball is in dynes, and current I is in amps.

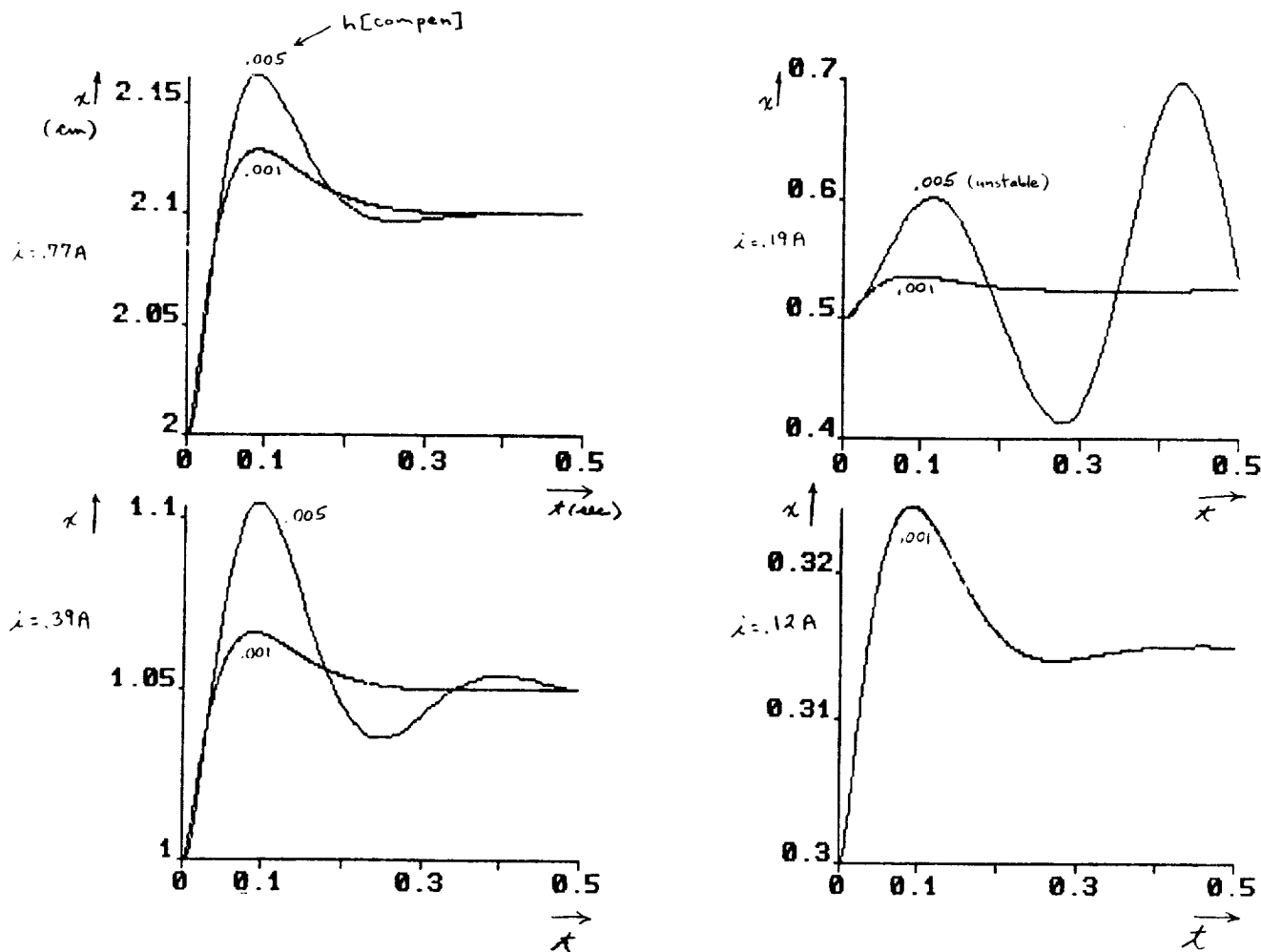

Figure 4: The closed-loop system with nonlinear compensation showing its performance with sampling periods h of 1 and 5 milliseconds as the operating point position is moved towards the pole face. Position x is in cm separation from the pole face. The nominal operating points are 2, 1, 0.5, and 0.3 cm respectively.

appears linear in terms of state variables z_1 , z_2 , and z_3 , and with a properly redefined input v . The states z_1 and z_2 are simply the original position and velocity. State z_3 is the acceleration applied to the suspended member. Thus it makes physical sense that the suspension will appear linear in z_3 . The suspension force happens to vary nonlinearly with the untransformed state and input, but Newton's law guarantees linearity in terms of a transformed state variable which is proportional to acceleration. In an implementation, the voltage drive u must be computed in terms of v :

$$u = -\frac{Mx_1v}{i} + iR. \quad (8)$$

Since v drives the derivative of z_3 , we can think of v as being a setpoint for the *slope* of the acceleration. Note that the coil resistance voltage drop iR is directly added to the input u .

Thus we have found a set of linearizing transformations. However the transformations are not unique. Direct substitution will verify that the transformations $T_1 = x_1^2$, $T_2 = 2x_1x_2$,

$$T_3 = 2x_2^2 - \frac{2Ci^2}{Mx_1} \quad (9)$$

and

$$T_4 = -\frac{6Cx_2i^2}{Mx_1^2} + \frac{2i}{M}(Ri - u) \quad (10)$$

though more complex than the first set, do indeed globally linearize the system. Actually, there are an infinity of such transformations which linearize this system. This is a consequence of the nature of nonlinear systems. It is clear however that the first set has the greatest physical meaning, and thus would be chosen in any practical context. Note also that in the first set the transformed state z_3 need never be computed. This is so because the system is linear between the transformed input v and the original position state variable x_1 . Further, note that the input transformation (8) depends only upon position x_1 and current i . Both of these quantities may be readily measured.

5 Conclusions

As we have seen in the magnetic suspension examples, the technique of feedback linearization is of great utility in designing control loops for nonlinear systems such that the closed-loop systems are well-behaved despite large variations in operating point or disturbance forces. Sampling rates for discrete-time implementations have been shown to be critical, especially at small air gaps. For practical applications, the most important area which we have overlooked is that of robustness with respect to plant modeling errors. This is an area which has also been a topic of current research [5]. In [3] it is noted that the electromagnet nonlinearity results in nonlinear cross-coupling terms in the control of five degrees of freedom of a precision linear bearing suspension. Thus it will be advantageous to implement nonlinear compensation laws for this and other multivariable suspension systems.

6 Acknowledgements

This work forms part of a thesis submitted by the author to the Department of Electrical Engineering and Computer Science at M.I.T. in partial fulfillment of the requirements for the degree of Doctor of Philosophy [2]. The authors gratefully acknowledge the assistance of Van Pham, Tim Hawkey, Eric Heatzig, Dave Gessel, and Art Rudolf at M.I.T., and Carl Much, Mike Johnson, Pete Rossini, Paul Mitiguy, and Hardy Prince at M.I.T. Lincoln Laboratory. This work was sponsored by the Department of the Air Force, and performed at the M.I.T. Lincoln Laboratory.

7 References

- [1] Slocum, A.H., and Eisenhaure, D.B., "Design Considerations for Ultra-Precision Magnetic Bearing Supported Slides," NASA Magnetic Suspension Technology Conference, Hampton, Va. Feb. 2-4, 1988.

- [2] Trumper, D.L., "Magnetic Suspension Techniques for Precision Motion Control," Ph.D. Thesis, Dept. of Elec. Eng. and Comp. Sci., M.I.T., Camb., Mass., Sept., 1990.
- [3] Trumper, D.L., "Five-Degree-of-Freedom Control of an Ultra-Precision Magnetically-Suspended Linear Bearing," NASA Workshop on Aerospace Applications of Magnetic Suspension Technology, Hampton, VA, Sept. 25-27, 1990.
- [4] Slotine, and Li, preliminary notes for text on nonlinear control, to be published Jan., 1991. Used as course notes for MIT class 2.152.
- [5] Spong, M., and Vidyasagar, M., *Robot Dynamics and Control*, Wiley, 1989, pp. 259-283.
- [6] Su, R., "On the linear equivalents of nonlinear systems," *Systems and Control Letters*, vol. 2, No. 1, pp. 48-52, July, 1982.
- [7] Hunt, L.R., Su, R., and Meyer, G., "Global Transformations of Nonlinear Systems," *IEEE Transactions on Automatic Control*, Vol. AC-28, No. 1, Jan., 1983.
- [8] Hunt, L.R., Su, R., and Meyer, G., "Design for Multi-Input Nonlinear Systems," in *Differential Geometric Control Theory*, Brockett, Millman, and Sussmann, eds., *Progress in Mathematics*, Vol. 27, pp. 268-298, Birkhauser, Boston, 1983.
- [9] Meyer, G., Su, R., and Hunt, L.R., "Application of Nonlinear Transformations to Automatic Flight Control," *Automatica*, Vol. 20, No. 1, pp. 103-107, 1984.
- [10] Woodson, H.H., and Melcher, J.R., *Electromechanical Dynamics - Part I*, John Wiley and Sons, 1968.
- [11] Jayawant, B.V., Hodkinson, R.L., Wheeler, A.R., and Whorlow, R.J., "Transducers and Their Influence in the Design of Magnetically Suspended Vehicles," *I.E.E. Conf. on Control Aspects of New Forms of Guided Land Transport*, I.E.E. Publication No. 117, Aug., 1974, pp. 200-206.
- [12] Jayawant, B.V., Sinha, P.K., Wheeler, A.R., and Whorlow, R.J., "Development of 1-ton Magnetically Suspended Vehicle Using Controlled D.C. Electromagnets," *Proc. I.E.E.*, Vol. 123, No. 9, Sept., 1976.
- [13] Groom, N.J., and Waldeck, G.C., "Magnetic Suspension System for a Laboratory Model Annular Momentum Control Device," *AIAA Paper No. 79-1755*, 1979.
- [14] Traxler, A., Meyer, F., and Murbach, H., "Fast Digital Control of a Magnetic Bearing with a Microprocessor," *International Kongress Mikroelektronik*, Munich, Nov 13-15, 1984, pp 94-102.