

NASA
Technical Memorandum 103276

AVSCOM
Technical Report 90-C-015

Advanced Rotorcraft Transmission Program

(NASA-TM-103276) ADVANCED ROTORCRAFT
TRANSMISSION PROGRAM (NASA) 18 p CSCL 131

N91-21531

Unclas
G3/37 0003346

Robert C. Bill
Propulsion Directorate
U.S. Army Aviation Systems Command
Lewis Research Center
Cleveland, Ohio

Prepared for the
46th Annual American Helicopter Society Forum
Washington, D.C., May 21, 1990

NASA





ADVANCED ROTORCRAFT TRANSMISSION PROGRAM

Robert C. Bill
Propulsion Directorate
U.S. Army Aviation Systems Command
Lewis Research Center
Cleveland, Ohio 44135

SUMMARY

The Advanced Rotorcraft Transmission (ART) program is an Army-funded, joint Army/NASA program to develop and demonstrate lightweight, quiet, durable drivetrain systems for next generation rotorcraft. Contract participants in ART include Boeing Helicopters, Sikorsky Aircraft, McDonnell Douglas Helicopter Company, and Bell Helicopter Textron, Inc, with some in-house technical support provided at Lewis Research Center. ART addresses the drivetrain requirements of two distinct next generation aircraft classes: (1) Future Air Attack Vehicle, a 10 000 to 20 000 lb aircraft capable of undertaking tactical support and air-to-air missions; (2) Advanced Cargo Aircraft, a 60 000 to 80 000 lb aircraft capable of heavy lift field support operations. Both tiltrotor and more conventional helicopter configurations are included in the ART program. Specific objectives of ART include reduction of drivetrain weight by 25 percent compared to baseline state-of-the-art drive systems configured and sized for the next generation aircraft, reduction of noise level at the transmission source by 10 dB relative to a suitably sized and configured baseline, and attainment of at least a 5000 hr mean-time-between-removal.

The technical approach for achieving the ART goals includes application of the latest available component, material, and lubrication technology to advanced concept drivetrains that utilize new ideas in gear configuration, transmission layout, and airframe/drivetrain integration. To date, candidate drivetrain systems have been carried to a conceptual design stage, and trade-off studies have been conducted resulting in selection of an ART transmission configuration for each of the four contractors. The final selection was based on comparative weight, noise, and reliability studies. A description of each of the selected ART designs is included in this paper. Preliminary design of each of the four selected ART transmissions has been completed, as have mission impact studies wherein comparisons of aircraft mission performance and life cycle costs are undertaken for the next generation aircraft with ART and with the baseline transmission.

INTRODUCTION

The Advanced Rotorcraft Transmission (ART) Technology Integration Demonstration is an Army/NASA program incorporating key emerging material and component technologies and new design concepts for advanced rotorcraft transmissions. The intent is to make a quantum jump in the rotorcraft drivetrain state-of-the-art. The program provides for the design component validation, construction and testing of two different sized transmissions. One size range will be applicable to a 10 000 to 20 000 lb gross weight Future Air Attack Vehicle (FAAV) The other size is for a 60 000 to 85 000 lb Advanced Cargo Aircraft (ACA). There are three objectives to the ART program: (1) rotorcraft

transmission weight is to be reduced by 25 percent relative to design and component capabilities represented by the currently fielded transmission state-of-the-art; (2) transmission noise generation is to be reduced by 10 dB compared to state-of-the-art capabilities; and (3) mean time between removal (MTBR) is to be at least 5000 hr. These are recognized as being ambitious but realistic objectives, and address attributes of rotorcraft transmissions that significantly impact aircraft performance. ART is viewed as providing the rotorcraft industry a unique opportunity to advance the technology baseline of transmissions via a path similar to that traditionally followed in engine development, namely through technology demonstrator programs.

ART consists of two phases. The first phase, is the "Preliminary Design and Component Validation" phase, and it involves four industry participants: Boeing Helicopters; Sikorsky Aircraft; McDonnell Douglas Helicopter Company; and Bell Helicopter Textron Incorporated. In the early part of this phase the aircraft mission was selected and a conceptual baseline transmission representing the currently fielded state-of-the-art was defined. This provided the basis for comparing different advanced design concepts and for assessing the impact of various component technologies. Final selection of the ART transmission configuration was then made, and a list of key technologies requiring validation was developed. The selected ART transmission was analytically compared with the baseline transmission in a mission impact study that addressed aircraft performance and Life Cycle Costs (LCC)

The following sections of this paper describe the ART transmission configurations selected by each of the contract participants, the key technologies incorporated in the ART program, and the results of the mission impact studies.

ART TRANSMISSION CONFIGURATION SELECTIONS

From its inception, the ART program addressed two distinctly different size, next generation aircraft: (1) 10 000 to 20 000 lb class attack rotorcraft; (2) 60 000 to 85 000 lb class cargo rotorcraft. The power transmission systems for these two aircraft classes are different enough in size to represent two clearly separated scaling ranges and to admit for consideration complementary sets of candidate configurations and technologies. For each of the four contractors, the aircraft selected for ART application and the candidate ART configurations are summarized in table I. A brief description, including configuration schematics and significant attributes, is shown in table II for each of the general categories of candidate ART configurations studied.

Key to the selection process was the definition of a meaningful baseline transmission. Each ART participant developed a conceptual baseline that was very closely tied from both configuration and component technology standpoints to a currently produced or fielded system. This baseline drivetrain was then scaled up or down to fit the power requirements of the aircraft application selected for ART. Also, minor configurational adjustments were made to allow for differences in overall reduction ratios and input/output arrangements between the ART aircraft and the system from which the baseline was derived. Weight definition of this baseline, to the accuracy necessary for the trade-off studies involving the ART candidates, was fairly straightforward. Reliability

definition generally stemmed from service experience records combined with component specific statistical life calculations. Noise characteristics were more difficult to define since in some cases, the noise levels of the production or fielded system from which the baseline was derived was not very well defined, and because scaling laws for noise prediction are not well established. Nevertheless, fair though somewhat qualitative bases for noise comparisons were established.

The comparisons and trade-offs between the candidate ART configurations were conducted on the basis of the primary objectives of the ART program. Fairly straightforward weight comparison studies were carried out, and probably provided the comparative measure that carried the highest level of confidence. In some cases, well substantiated component weight trending models were applied (ref. 1) and where these were not applicable because of major variations from the trending base, weights were directly calculated from the design.

Reliability considerations were based on a number of factors including part counts coupled with analytical component life predictions, field experience factors adjusted for differences between the baseline transmission and the ART candidate, and newly developed statistical life prediction codes for transmission systems (ref. 2). Component reliability improvements resulting from application of new materials and lubrication methods were addressed through application of appropriate life adjustment factors to the basic life calculations (ref. 3).

Prediction of the noise characteristics for the candidate configurations was the most difficult and uncertain of the bases for comparison. In general, baseline transmission noise data was used as a starting point. Extrapolation to each of the ART candidates was accomplished by comparing the number of gear meshes, mesh loading, gear geometry features, and mesh speeds with those of the baseline. The result was typically a very qualitative comparison with a net judgment for each candidate as to whether it would be better, worse, much better, much worse, or about the same as the baseline.

The screening and selection results are summarized in table III, with a brief indication of the primary reason for candidate rejection.

A single stage planetary was selected by Boeing Helicopters for application to their Tactical Tilt Rotor (TTR) FAAV. The aircraft is shown in figure 1. A schematic of the main gear box (two per aircraft) is shown in figure 2. The baseline drivetrain was derived from CH-47D component technology combined with the YUH-61 configuration definition. The basis for selection of the single stage planetary arrangement over the competing configurations was primarily a combination of weight and reliability considerations. The speed reduction taken in the planetary stage is roughly 5.4:1, which is somewhat higher than typical rotorcraft gearbox planetary reductions (typically 3 or 4:1). The arrangement, however, combined with extensive application of ceramic rolling element tapered roller bearings, advanced gear and bearing materials, herringbone planetary meshes and helical gearing throughout the rest of the drivetrain, resulted in a lightweight and compact design. Reliability gains are expected through the significant reduction in number of dynamic mechanical components and application of improved materials.

The configuration selected by Sikorsky Aircraft for application to the ACA (shown in fig. 3) consists of a split path main gear box with three inputs (three engines) and a final reduction ratio of 11:1. The baseline was derived from the CH-53E. By far the strongest feature of this configuration, shown in figure 4, was the very substantial drive train weight reduction realized largely through the inherent weight efficiency of the split path configuration for large aircraft, and application of composites to the housing, load truss, and main rotor quill shaft. Other significant weight reducing features include: Spring clutches; Ceramic spherical roller bearings; Composite coupling and shaft on the input quill; elastomeric torque splitting concept applied at the second mesh in the gearbox; and the ring design employed on the 48-in. herringbone bull gear. Additional benefits also resulted from application of advanced gear and bearing materials throughout the drivetrain, with increased contact and bending stress allowables, and higher temperature operating capability.

McDonnell Douglas Helicopter Company chose a novel split torque/planetary hybrid configuration for their ART NOTARY FAAV. The aircraft is shown in figure 5, and the selected transmission in figure 6. The baseline was derived directly from the AH-64A. A unique feature of the selected ART transmission is the use of a face gear arrangement to simultaneously split the torque between two input paths (per engine input) to the collector bull gear and to provide for the change in rotation axis normally accomplished with spiral bevel gears. In effect, an entire stage has been eliminated from the drivetrain, and a very compact torquesplitting arrangement identified. The free end of the face gear input shaft will be spring mounted, and this freedom will help assure efficient load sharing between the two torque paths. This configuration, in conjunction with advanced gear and bearing materials and weight saving gear web designs, resulted in a drivetrain that was projected to substantially exceed the 25 percent weight reduction goal.

The drivetrain selected by Bell Helicopter Textron Inc. was based on a single stage planetary main gear box with substantial speed reduction accomplished through an input helical spur gear train. The main gear box (two per aircraft) is shown in figure 7. The TTR configuration is similar to the Boeing TTR. Weight savings over the baseline drivetrain (XV-15 derived) were accomplished primarily through application of high contact ratio planetary gearing, thrust balanced helical input gearing (no thrust bearings required) use of advanced gear and bearing steels, employment of a high oil-in temperature lubrication system using a minimal quantity of lubricant and application of lightweight alloy castings to the planet carrier and the main gear box housings. Reliability improvements arose from the use of superior materials in dynamic mechanical components, resulting in longer statistical lives even with higher lubricant temperatures and higher load allowables. Low noise precision gear geometries throughout the drivetrain are expected to result in significant reduction in transmission noise generation.

KEY TECHNOLOGIES

The success of the ART configurations in meeting the program goals depends on the successful incorporation of certain critical, advanced technologies into the preliminary designs. The technologies can be divided into five categories: (1) Configuration specific items; (2) Materials and lubricants; (3) Generic

component technologies; (4) Noise technologies; and (5) analytical tools. The extent to which validation is required, and the manner in which incorporation is realized depends very much on the nature of the specific technologies in each of the categories.

Configuration Specific Items

Configuration specific items include design concepts and component applications unique to a particular transmission configuration. One such item is the tangentially compliant/radially stiff composite structure to be used by Sikorsky Aircraft in their split path ACA transmission. Shown in figure 8, the desired compliance is afforded by alternate layers of elastomer and steel compressively retained in the V-shaped space between the toothed gear rim and web on the input shaft of each of the bull gear drivers. The layered elastomer/steel geometry can be optimized to assure a nearly 50/50 torque split for each of the parallel bull gear input spindles, and provide sufficient radial stiffness to maintain precision meshing on each spindle. The concept will be validated by a one-half scale main gearbox demonstration test.

Another configuration specific concept is the face gear torque splitting design by McDonnell Douglas Helicopter Company for their FAAV main gearbox. Nearly 50/50 torque splitting appears to be assured by the cantilevered input shaft design wherein the face gear mesh is "free" floating (will actually be spring supported). This free floating feature guarantees that the mesh loads balance. Although gear mesh geometry details essentially consist of a conventional spur gear in contact with a "wraparound" rack, there is no high speed, high power face gear experience base. Hence, some validation work is necessary to fully understand face gear mesh dynamics and life limiting considerations.

Material and Lubricants

One of the features shared by all participants in the ART program is the full exploitation of the increased capabilities of high hot hardness gear steels. These steels were developed over the last 10 to 15 years, and they have potential to operate at significantly increased temperatures (ref. 4) compared to AISI 9310 gear steel representative of baseline technology. Under standard conditions, the fatigue lives demonstrated by high hot hardness steels are several times that of the AISI 9310 baseline (ref. 5), and they show substantially improved scoring resistance as well. Some examples of high hot hardness gear steels chosen for the ART program include VIM-VAR EX-53 and Vasco X-2. It is expected that these steels will enable operation at 500F higher oil inlet temperature than AISI 9310, with an attendant improvement in reliability. Potentially, operation at 1000 °F higher oil temperature may be possible. Of course, significant oil cooler and oil reservoir weight savings can be realized if 50 to 1000 °F oil temperature increases can be achieved without sacrificing life and reliability.

The incorporation of ceramic rolling element bearings in certain key locations, primarily at or near the high speed input stages is consistent with the desire to operate the main gear box "hotter and lighter". Although some up front weight savings result from use of the lighter-than-steel ceramic rolling

elements (generally high technology Si_3N_4), the high hot hardness properties of the ceramic and reduced dynamic loading on the races provide the real benefit.

Major weight savings can be realized through the application of composite structural materials. The ACA transmission design of Sikorsky Aircraft is particularly amenable to incorporation of composites because of the geometric simplicity of the housing and truss, and also because of the major weight benefits realizable from such large components. The main gearbox housing is comprised of flat end pieces and simple cylindrical sides elements. The moment/life load reacting truss is made of simple structural shapes. Provision can be made for integral lube passages in the housing through incorporation of embedded tubing. Along with composite mast and input shaft hardware, it is estimated that application of lightweight structural composites to the ART ACA transmission results in 700 to 800 lb weight reduction compared to baseline materials.

The lubrication/cooling system for the main gearbox provides a major opportunity for weight savings. From a heat rejection standpoint, the factors that drive the weight of the lubrication system include the required heat transfer area, necessary volume of lubricant to stabilize temperature at the required level, associated lubricant containment and pumping, and the necessary cooling fan, motor, housing and peripheral hardware. All of these factors increase the weight roughly in proportion to the required rate of heat rejection. On the other hand, if the allowable lubricant temperature can be increased, the proportional increase in heat transfer effectiveness will allow the required lubricant/cooling system weight to be proportionally decreased. In effect, this means that if oil-in temperatures can be allowed to increase by 1000 °F because of improved transmission materials and design, then the weight of the lubrication/cooling system can be decreased by approximately 50 percent. This weight reduction is being vigorously pursued in the ART program, and has as an additional benefit of a reduction in the battlefield damage vulnerable area.

Technological advances in light alloy casting have been exploited in the ART program as a way of producing lightweight housings and planet carriers. The key advances are in the areas of precision thin section casting of new corrosion resistant magnesium alloys and structural titanium alloys. In addition to weight savings, considerable potential for manufacturing cost reduction can be realized.

Another significant cost saving manufacturing technology being exploited in ART is precision near net shape forging of gears. As forged dimensions are actually within 0.010 to 0.020 in. of the final gear profile. Following heat treatment, tooth profiles may be achieved through finish grinding alone. An added benefit associated with near net forged gearing is an improvement in gear tooth bending fatigue resistance, which of course impacts weight and reliability.

Generic Component Technologies

Some of the gear, bearing, and clutch component technologies being pursued in the ART program are not configuration specific. That is, they are equally applicable to any and all transmission configurations. For instance, the newly developed spring clutch concept provides an opportunity to save input module weight primarily through reduced size envelope of the clutch hardware compared

to conventional sprag clutch designs. Other widely applicable clutch concepts being addressed in the ART program include advanced sprag configurations, and positive engagement clutch ideas. Aside from helping to achieve weight goals, all of these clutch ideas also impact drivetrain field reliability.

All of the ART participants are taking advantage of advances in gear tooth profile design and manufacturing technology. Features that improve meshing characteristics under off-design load or slight misalignment conditions are being incorporated. Such features include optimum tip relief, controlled deviations from zero kinematic error profiles, and optimum crowning. In combination with judiciously applied high contact ratio gearing and conformal tooth designs, low noise long life gearing is anticipated for ART. A key to the successful application of advanced precision gearing features is the increasing availability of the latest CNC grinding and shaping capabilities.

Advances in bi-directional tapered roller bearing technology have been applied by the ART participants to reduce the weight, complexity, and size envelope of radially and axially loaded bearing systems. A concern that has held up the application of bi-directional bearings was lack of tolerance for marginal lubrication or loss of lubrication conditions. New rib design features (refs. 6 and 7), analytically guided rolling element geometry, and application of higher temperature bearing materials have all contributed considerably toward improving marginal lubrication tolerance in bi-directional rolling element bearings.

Noise Technologies

Technologies directed toward meeting the ART noise reduction objective fall into three categories: (1) Minimization of mesh generated noise through gear profile design; (2) Introduction of noise attenuating interfaces in the structural noise conduction path; and (3) Application of active noise cancellation techniques.

Mesh generated noise arises primarily from kinematic error associated with the gear tooth profile (ref. 8) Improved precision in tooth profile generation, and the incorporation of special design features such as tip relief and crowning are expected to significantly reduce gear mesh action as a source of noise (ref. 9). In addition, noninvolute tooth forms and advanced design/manufacturing techniques for consistent generation of near-conjugate action spiral bevel gears are being pursued. Bell Helicopter Textron, Inc., is especially active in applying advanced technology spiral bevel gearing to the ART program.

Noise attenuating interfaces can be an effective way of acoustically isolating the mesh from the noise conducting structural path. The laminar elastomeric composites employed by Sikorsky Aircraft for torque-splitting purposes, and elastomeric spline inserts incorporated in input pinion gear webs by McDonnell Douglas Helicopter Co., are both examples of noise attenuating interfaces.

An active noise control approach is being pursued by Boeing Helicopters. This approach consists of applying feedback drive piezo-electric actuators to judiciously chosen locations on the transmission housing, or possibly at the transmission mounting points. The actuators are driven out-of-phase with the

major noise excitations, thereby cancelling out significant portions of the noise. Very promising results have come from preliminary bench tests that have been completed.

Analytical Tools

The ART program benefitted immensely from the availability of computational analysis capabilities developed over the past decade. It was possible to quickly develop and modify component and system designs and to undertake concept trade-off studies. The impact of individual technologies could be expeditiously evaluated in the preliminary design stage. Application of sophisticated structural analysis codes at the detail design stage permitted optimization of components, and accurate prediction of static, dynamic, and thermal strains throughout the drive system. Because of these capabilities it was possible for the first time to meaningfully assess a large number of very different drivetrain configurations and component technologies, and to approach an optimum embodiment of a selected configuration.

MISSION IMPACT

Analytical mission impact studies were conducted by each of the ART participants. In each of these studies, the mission benefits and life cycle cost reductions resulting from incorporation of the ART drivetrain in the selected aircraft were identified. The selected aircraft with the baseline transmission served as the basis for these comparisons.

The original ART program ground rules called for sizing the aircraft to meet mission requirements (essentially a range/payload requirement) with the baseline drivetrain. Then, with the ART drivetrain incorporated in the aircraft, improvements in range and payload parameters could be identified. Life cycle cost reductions would result primarily from reduced maintenance costs associated with the MTBR. Figure 9, from the Boeing Helicopter FAAV studies summarize and typify mission impact studies carried to this point. Essentially, a 40 to 50 mile increase in combat radius or a 400 to 500 lb increase in combat payload could be realized.

Continuing the study a step further, if the mission, including range and payload, is held constant, further substantial benefits in terms of aircraft efficiency can be realized through application of ART. Now, the entire aircraft can actually be scaled down because of the reduced empty weight factor and lower flight power demands (smaller fuel load required) that result from a 25 percent reduction in drivetrain weight. For the case of Sikorsky's ACA, this optimization step in aircraft/drivetrain integration resulted in an aircraft gross weight reduction of approximately 4000 lb, while the original mission requirements are still met.

The reduced aircraft size made possible through the application of ART, results in significant reductions in aircraft acquisition and operating costs. These savings, or improvements in aircraft system efficiency, combined with the expected improvements in drivetrain life and reliability due to application of ART, result in very substantial life cycle cost savings. The mission impact studies and life cycle cost analyses conducted by all four ART participants are

summarized in table IV. Note that the three FAAV studies are in good general agreement.

CONCLUSIONS

Studies and analyses conducted to date indicate that the Advanced Rotorcraft Transmission will meet the 25 percent weight reduction objective, and achieve a 5000 hr MTBR. Actual noise reduction is more difficult to predict, but major progress toward achieving the 10 dB target is expected, through the incorporation of advanced gear mesh concepts and noise reduction techniques. Though there were no formal Life Cycle Cost reduction program objectives, very major cost savings are anticipated, arising partly from reduced acquisition costs (lighter, small aircraft to perform given mission), and reductions in operation and support costs. The intent of the ART program to fully exploit available, advanced component, material, lubrication, and analytical technologies in the framework of new, innovative transmission configurations is being fully exercised.

REFERENCES

1. Schmidt, A.H., "A Method for Estimating the Weight of Aircraft Transmissions," Society of Allied Weight Engineers 35th Annual Conference, Philadelphia, PA, Paper 1120, May 1976.
2. Savage, M. and Lewicki, D., "Transmission Overhaul and Replacement Predictions Using Weibull and Renewal Theory," NASA TM-102022, July 1989.
3. Coy, J.J., Townsend, D.P., and Zaretsky, E.V., "Gearing," NASA RP-1152, December 1985.
4. Townsend, D.P., "Surface Fatigue Life and Failure Characteristics of EX-53, CB-1000 M, and AISI 9310 Gear Materials," NASA TP-2513, October 1985.
5. Fisher, G.K., "Advanced Power Transmission Technology," NASA CP-2210, January 1983, p. 429.
6. Kreider, G.E., and Lee, P.W., "Improved Oil-Off Survivability of Tapered Roller Bearings," NASA CR-180804, 1987.
7. Lenglade, R., Kreider, G.E., and Pech, R., "A Bidirectional Tapered Roller Thrust Bearing for Gas Turbine Engines," AIAA 87-1842, July 1987.
8. Coy, J.J., et al., "Identification and Proposed Control of Helicopter Transmission Noise at the Source," NASA TM-89312, March 1987.
9. Litvin, F.L., et al., "Transmission Errors and Bearing Contact of Spur, Helical, and Spiral Bevel Gears," SAE Paper 881294, September 1988.

TABLE I. - ART CANDIDATE TRANSMISSIONS

Contractor	Aircraft type	Baseline transmission	Candidate configurations
Boeing Helicopters	FAAV (Tiltrotor)	Two-stage planetary (CH-47 + YUH-61)	Split torque (two versions) Self-aligning bearingless planetary Single stage planetary
Sikorsky Aircraft	ACA (Single rotor)	Two-stage planetary (CH-53E)	11:1 Split path 8:1 Split path 11:1 Split torque 8:1 Split torque
McDonnell Douglas Helicopter Company	FAAV (Notor [®] Heli)	Single stage planetary (AH-64A)	Planetary (three versions) Self-aligning bearingless planetary Split torque
Bell Helicopter Textron, Inc.	FAAV (Tiltrotor)	Two-stage planetary (XV-15)	Single stage planetary Split power planetary Compound planetary Self-aligning bearingless planetary

TABLE II. - DESCRIPTION OF ART CANDIDATE CONFIGURATION TYPES

Configuration type	Schematic	Basic attributes
Self-aligning bearingless planetary		<ul style="list-style-type: none"> • Elimination of planet carriers and bearings • Static load cancellation through aligned meshes • Tracking and positioning through roller rings
Split torque		<ul style="list-style-type: none"> • Multiple parallel torque load paths • Structural flexibility to achieve torque split • Design flexibility in optimizing mesh loads
Conventional planetary		<ul style="list-style-type: none"> • Effective mesh load sharing over limited reduction range • Compact geometric arrangement • Extensive experience baseline

ORIGINAL PAGE IS
OF POOR QUALITY

TABLE III. - ART CONFIGURATION SELECTION SUMMARY

Contractor	Candidate configurations	Rejection criteria
Boeing Helicopters	Split torque (two versions) Self-aligning bearingless planetary Single stage planetary ^a	Weight Noise, reliability
Sikorsky Aircraft	11:1 Split path ^a 8:1 Split path 11:1 Split torque 8:1 Split torque	Weight Weight, reliability Weight, reliability, noise
McDonnell Douglas Helicopter Company	Planetary (three versions) Self-aligning bearingless planetary Split torque ^a	Weight Weight, reliability
Bell Helicopter Textron Inc.	Single stage planetary ^a Split power planetary Compound planetary Self-aligning bearingless planetary	Noise, reliability Weight Weight

^aSelected configuration.

TABLE IV. - ART IMPACT ON AIRCRAFT

[Based on 600 a/c, 25 year, 420 FH per year.]

	Sikorsky ^a (ACA)	Boeing (FAR-TTR)	MDHC (FAR)	Bell (FAR-TTR)
Transmission weight, lb	7879(-27%)	1359(-25%)	1344(-25%)	1388(-17%)
Gross weight, lb	81 957(-4%)	16 224(-6%)	16 600(-4%)	16 538(-4%)
Transmission acquisition cost, \$ per a/c	\$1.12M(-25%)	\$0.63M(-14%)	\$0.54M(-24%)	\$0.56M(-27%)
Transmission direct operating cost, \$ per FH per unit	\$88(-78%)	\$37(-24%)	\$49(-33%)	\$113(-19%)
Aircraft fleet life cycle cost savings, \$	\$1.7B	\$0.30B	\$0.42B	\$0.33B

^aBased on 35 year, 240 FH per year.

ORIGINAL PAGE IS
OF POOR QUALITY

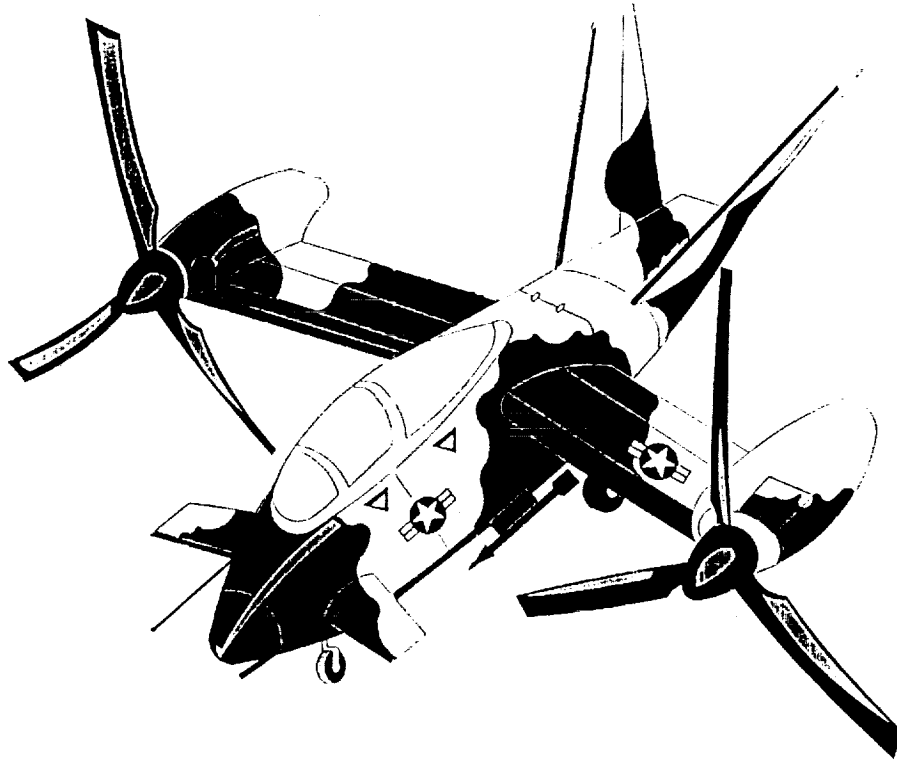

FIGURE 1. - TACTICAL TILT ROTOR PROPOSED BY BOEING HELICOPTER COMPANY AS FAAV CANDIDATE FOR ART.

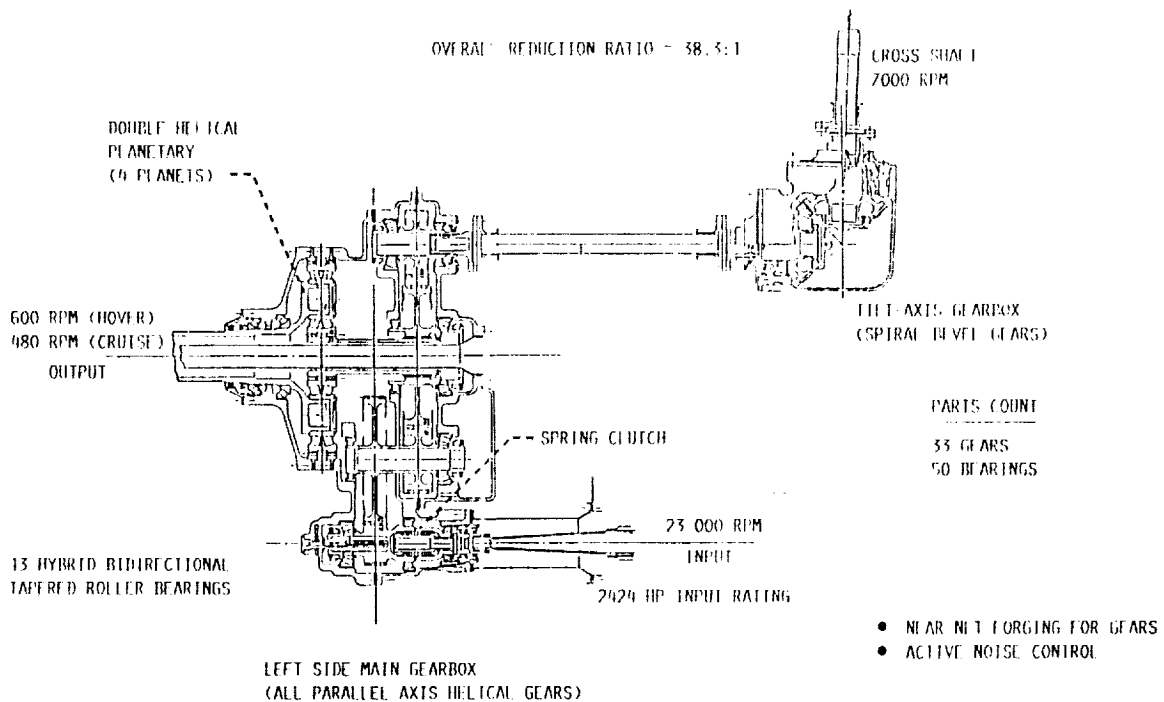

FIGURE 2. - SINGLE STAGE PLANETARY MAIN GEAR BOX SELECTED BY BOEING HELICOPTER COMPANY.

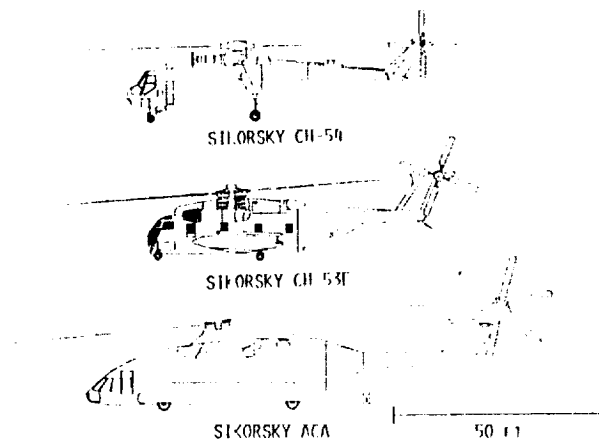

FIGURE 3. - SIKORSKY ACA CONFIGURATION.

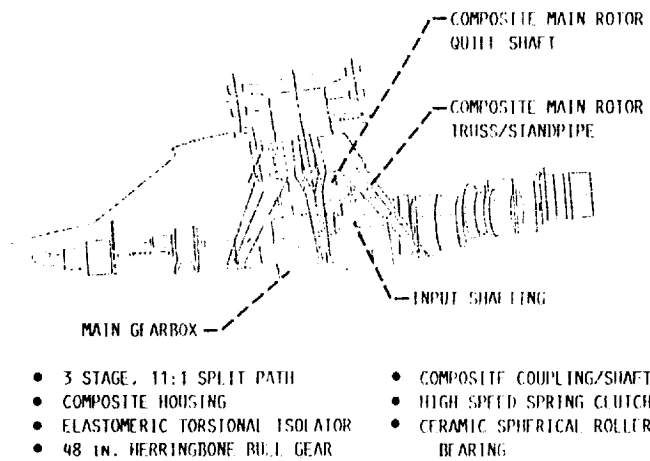

FIGURE 4. - SPLIT PATH MAIN GEAR BOX SELECTED BY SIKORSKY.

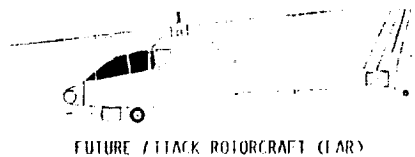
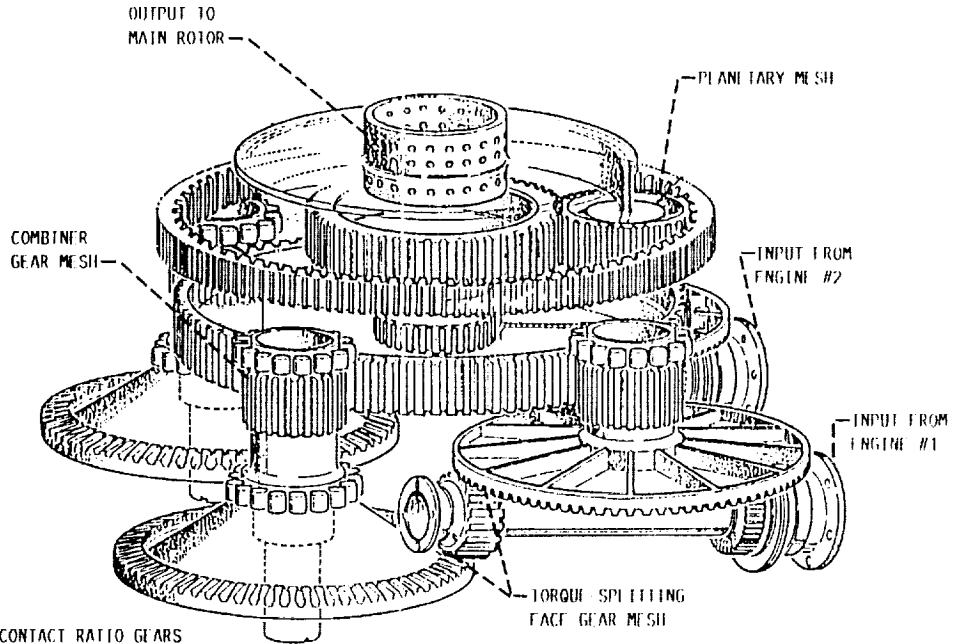
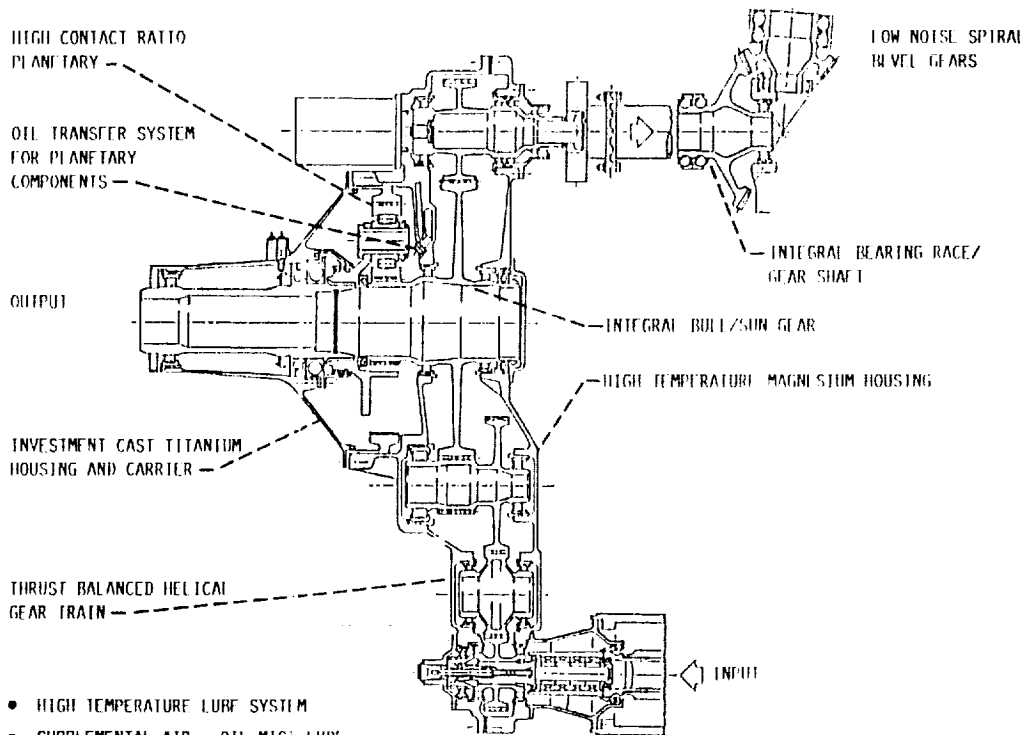

FIGURE 5. - McDONNELL DOUGLAS HELICOPTER COMPANY NOTAR[®] FAAV.



- HIGH CONTACT RATIO GEARS
- CONFORMAL AND BUTTRESS TOOTH FORMS
- PASSIVE NOISE ATTENUATION SPLINED ELASTOMERIC INSERTS
- POSITIVE ENGAGEMENT CLUTCH

FIGURE 6. - SPLIT TORQUE MAIN GEAR BOX SELECTED BY McDONNELL DOUGLAS HELICOPTER COMPANY.



- HIGH TEMPERATURE LUBE SYSTEM
- SUPPLEMENTAL AIR - OIL MIST LUBE SYSTEM (FOR LOSS OF LUBE CONDITION)
- FAILSAFE COMPOSITE/STEEL MAST

FIGURE 7. - SINGLE STAGE PLANETARY GEAR BOX SELECTED BY BELL HELICOPTER TEXTRON INC.

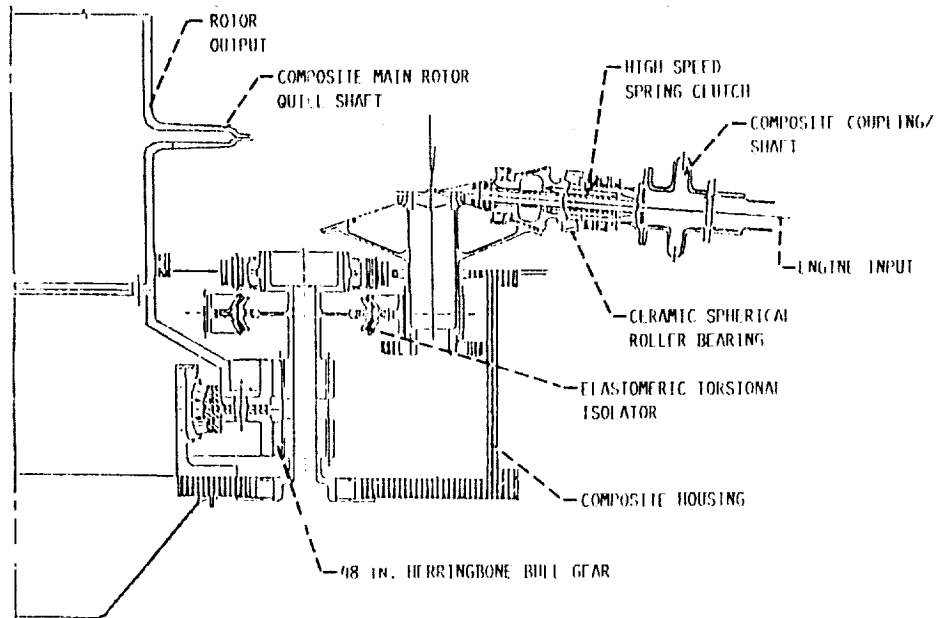

FIGURE 8. - TORQUE SHARING FEATURE EMPLOYED IN SIKORSKY AIRCRAFT SPLIT PATH MAIN GEAR BOX.

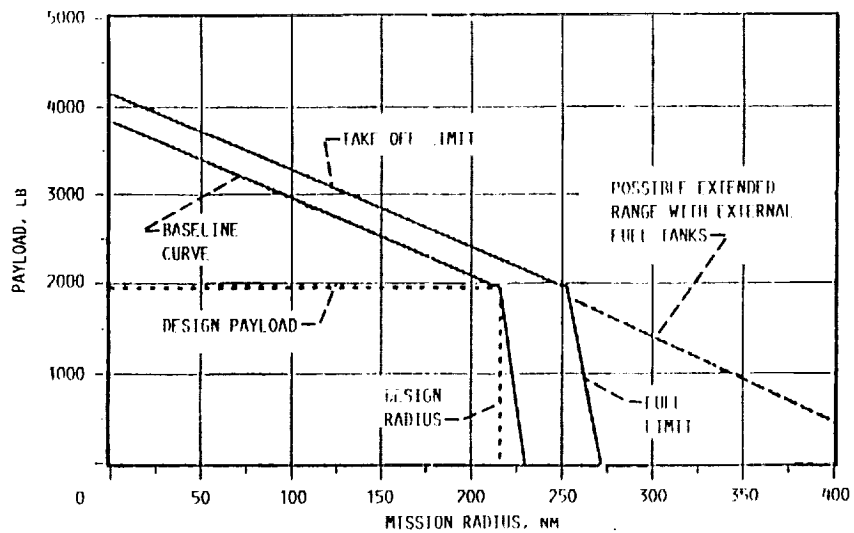

FIGURE 9. - RANGE - PAYLOAD IMPACT OF ART DRIVETRAIN ON BOEING HELICOPTER COMPANY'S FAHV TTR.

ORIGINAL PAGE IS
OF POOR QUALITY

1. Report No. NASA TM-103276 AVSCOM TR 90-C-015		2. Government Accession No.		3. Recipient's Catalog No.	
4. Title and Subtitle Advanced Rotorcraft Transmission Program				5. Report Date	
				6. Performing Organization Code	
7. Author(s) Robert C. Bill				8. Performing Organization Report No. E-5722	
				10. Work Unit No. 505-62-OK 1L162211A47A	
9. Performing Organization Name and Address NASA Lewis Research Center Cleveland, Ohio 44135-3191 and Propulsion Directorate U.S. Army Aviation Systems Command Cleveland, Ohio 44135-3191				11. Contract or Grant No.	
				13. Type of Report and Period Covered Technical Memorandum	
12. Sponsoring Agency Name and Address National Aeronautics and Space Administration Washington, D.C. 20546-0001 and U.S. Army Aviation Systems Command St. Louis, Mo. 63120-1798				14. Sponsoring Agency Code	
				15. Supplementary Notes Prepared for the 46th Annual American Helicopter Society Forum, Washington, D.C., May 21, 1990.	
16. Abstract <p>The Advanced Rotorcraft Transmission (ART) program is an Army-funded, joint Army/NASA program to develop and demonstrate lightweight, quiet, durable drivetrain systems for next generation rotorcraft. Contract participants in ART include Boeing Helicopters, Sikorsky Aircraft, McDonnell Douglas Helicopter Company, and Bell Helicopter Textron, Inc., with some in-house technical support provided at Lewis Research Center. ART addresses the drivetrain requirements of two distinct next generation aircraft classes: (1) Future Air Attack Vehicle, a 10 000 to 20 000 lb aircraft capable of undertaking tactical support and air-to-air missions; (2) Advanced Cargo Aircraft, a 60 000 to 80 000 lb aircraft capable of heavy lift field support operations. Both tiltrotor and more conventional helicopter configurations are included in the ART program. Specific objectives of ART include reduction of drivetrain weight by 25 percent compared to baseline state-of-the-art drive systems configured and sized for the next generation aircraft, reduction of noise level at the transmission source by 10 dB relative to a suitably sized and configured baseline, and attainment of at least a 5000 hr mean-time-between-removal. The technical approach for achieving the ART goals includes application of the latest available component, material, and lubrication technology to advanced concept drivetrains that utilize new ideas in gear configuration, transmission layout, and airframe/drivetrain integration. To date, candidate drivetrain systems have been carried to a conceptual design stage, and trade-off studies have been conducted resulting in selection of an ART transmission configuration for each of the four contractors. The final selection was based on comparative weight, noise, and reliability studies. A description of each of the selected ART designs is included in this paper. Preliminary design of each of the four selected ART transmissions has been completed, as have mission impact studies wherein comparisons of aircraft mission performance and life cycle costs are undertaken for the next generation aircraft with ART and with the baseline transmission.</p>					
17. Key Words (Suggested by Author(s)) Rotorcraft; Transmission; Component technology; Reliability; Noise; Weight			18. Distribution Statement Unclassified - Unlimited Subject Category 37		
19. Security Classif. (of this report) Unclassified		20. Security Classif. (of this page) Unclassified		21. No. of pages 16	22. Price* A03