

N91-22151

PULSED PLASMOID ELECTRIC PROPULSION

Robert F. Bourque, Paul B. Parks, and Teruo Tamano
General Atomics
San Diego, CA 92138

ABSTRACT

A method of electric propulsion is explored where plasmoids such as spheromaks and field-reversed configurations (FRC) are formed and then allowed to expand down a diverging conducting shell. The plasmoids contain a toroidal electric current that provides both heating and a confining magnetic field. They are free to translate because there are no externally-supplied magnetic fields that would restrict motion. Image currents in the diverging conducting shell keep the plasmoids from contacting the wall. Because these currents translate relative to the wall, losses due to magnetic flux diffusion into the wall are minimized. During the expansion of the plasma in the diverging cone, both the inductive and thermal plasma energy are converted to directed kinetic energy producing thrust. Specific impulses can be in the 4000 to 20000 sec range with thrusts from 0.1 to 1000 Newtons, depending on available power.

BACKGROUND

While chemical rockets are capable of very high thrust, consumption of propellant is excessive for many space missions such as long-term satellite station keeping and planetary missions. Their nozzle exhaust velocities are limited by heats of reaction to $u_e \simeq 5000$ m/sec, limiting specific impulse to $I_s \simeq 500$ sec. Nuclear thermal rockets using hydrogen propellant can approach 950 sec, still too low for many missions.

For many space missions, specific impulses in the 2000 to 10000 sec range are desirable in order to limit propellant consumption. However, the power in the exhaust stream

$$P_e = \frac{1}{2} \dot{m} u_e^2 ,$$

must be supplied by means other than chemical. Here \dot{m} is the propellant mass flow in kg/sec. The only practical form is electrical power and an electric generator, either solar or nuclear (fission or fusion), must be carried on board. (Batteries, fuel cells, and other chemical energy systems are not suitable because their fuel supply or energy storage mass is comparable to, and subject to the same limitations as, chemical rockets.)

When one trades off power plant mass against propellant mass, it becomes clear that every mission has an optimum specific impulse above which power plant mass becomes excessive and below which propellant mass dominates.

In terms of propulsion, space missions can be characterized by a certain payload mass m_p carried through a velocity increment ΔV . Typical ΔV s range from 9 km/sec to go from low earth to geosynchronous earth orbits (LEO - GEO), to 14 km/sec to go from LEO to Mars orbit and return, to 110 km/sec to go from LEO to Saturn orbit and return (ref. 1). Payload masses can range from 10s of kg for a small experimental satellite to hundreds of tonnes for a manned Mars mission.

Existing electrically-powered thrusters can supply high specific impulse at rather low thrust. There are three kinds: electrothermal (resistojets and arcjets), electrostatic (ion thrusters), and electromagnetic (magnetoplasmadynamic (MPD) thrusters).

Resistojets use resistance wire to heat a flowing gas. Arcjets do the same with arc discharges across the gas. Ion thrusters use perforated accelerator plates at high potential difference to accelerate an ionized gas. MPD thrusters are similar to arcjets except they also exploit the $\mathbf{J} \times \mathbf{B}$ force in the arc to blow the plasma through a nozzle.

Only the MPD thruster is capable of both high thrust and high specific impulse. However, these thrusters have rather short lifetimes due to electrode erosion (ref. 2). The plasmoid propulsion thruster discussed below may fill the need for high-power levels with long life and high specific impulse.

DESCRIPTION OF THE CONCEPT

The basic idea is shown in Fig. 1. Compact tori (CT) are formed inside an electrically conducting chamber. A compact torus is a toroidal-shaped ionized gas containing an internal electric current traveling mainly along the minor axis of the torus. Formation can be either by a coaxial Marshall gun or by a rapidly pulsed induction coil. Because the internal current can twist helically at locations off the minor axis, the configuration could take two forms: (1) a spheromak which has near-equal magnetic field strength at the plasma edge in directions parallel and perpendicular to minor axis, or (2) a field-reversed configuration (FRC) where the current has no helical twist and all of the magnetic field from that current is perpendicular to the minor axis. Both configurations are being explored for nuclear fusion applications. The difference between the two is that the FRC may be capable of higher plasma pressure but appears to have poorer confinement of the plasma thermal energy than the spheromak.

Once formed, the compact torus or plasmoid is pushed into a diverging conducting shell where it spontaneously accelerates down the divergence so as to reduce its internal

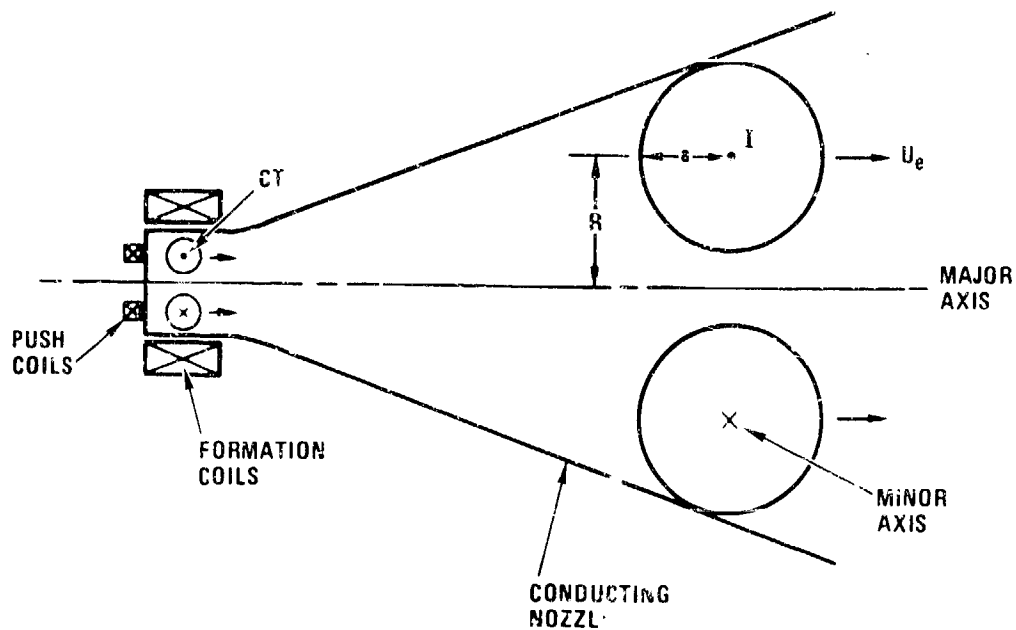

Fig. 1. Plasmoid propulsion concept.

pressure. Image currents in the shell keep the plasma off the wall and provide the physical push that gives the thrust.

This is a pulsed system and thrust variation is accomplished by simply varying the rate at which these plasmoids are formed. We believe that realistic pulse rates can vary from 100 Hz on down.

ANALYSIS

In this section, we examined the dynamics and energetics of plasmoid expansion down the conducting shell in order to arrive at preliminary estimates of specific impulse, thrust, and losses.

The magnetic energy in the plasma is

$$E_m = \frac{1}{2} L I^2 \quad ,$$

where I is the internal current in the plasma. L is the plasma inductance and is very nearly $\mu_0 R$ for aspect ratios $R/a \approx 1.5$, typical of spheromaks. Here μ_0 is the

magnetic permeability of free space; and a and R are the plasma minor and major radii, respectively. The thermal energy, assuming electron and ion temperatures are equal, is

$$E_t = 3n T V_p \quad ,$$

where n and T are the ion density and temperature, respectively, and V_p the plasma volume ($= 2\pi^2 R a^2$).

During an adiabatic expansion, total magnetic flux is conserved. That is,

$$B_p a R = \text{constant} \quad ,$$

where B_p is the magnetic field due to the plasma current I :

$$B_p = \frac{\mu_0 I}{2\pi a} \quad .$$

Assuming geometric similarity during expansion ($R \sim a$), it can be shown that

$$I a = \text{constant} \quad ,$$

Therefore, as the plasma expands, the internal total current drops linearly with size.

Over an expansion from a_1 to a_2 , it can be shown from the above that the magnetic energy scales like

$$\frac{E_{m2}}{E_{m1}} = \frac{a_1}{a_2} \quad .$$

A five-fold increase in size will therefore convert 80% of the magnetic energy to kinetic energy of the particles by interaction of the plasma current and the image current in the inclined shell.

The thermal energy in the plasma is also converted to kinetic energy during expansion. With an adiabatic expansion

$$\frac{n_2}{n_1} = \left[\frac{a_1}{a_2} \right]^3 \equiv \chi \quad ,$$

$$\frac{T_2}{T_1} = \chi^{\gamma-1} \quad .$$

Since, for hydrogen, $\gamma = 5/3$, the thermal energy scales like

$$\frac{E_{t2}}{E_{t1}} = \left[\frac{a_1}{a_2} \right]^2 \quad .$$

A five-fold linear expansion will therefore recover 96% of the thermal energy in the plasma and, like the expansion in a regular nozzle, convert it to kinetic energy.

Also of interest is the behavior of β during expansion. β is the ratio of plasma pressure to magnetic field pressure and is a measure of containment efficiency of the plasma configuration:

$$\beta \sim \frac{nT}{(I/a)^2} \quad .$$

It can be shown from the above equations that

$$\frac{\beta_2}{\beta_1} = \frac{a_1}{a_2} \quad .$$

Therefore, β is highest at the beginning of expansion. Any disruption of the plasma is likely to occur then rather than later. A disruption is when the plasma structure rapidly breaks down due to pressure-related instabilities. However, since the nozzle presents a free boundary to the plasma, particle motion will be downstream and thrust should be achieved anyway, albeit in a less organized fashion.

If, for simplicity, we assume that all of the plasma energy $E_{\text{tot}} = E_m + E_t$ goes to kinetic energy, then the exhaust velocity is

$$u_e = \left[\frac{2 E_{\text{tot}}}{M} \right]^{1/2} \quad ,$$

where M is the total plasma mass:

$$M = (1.67 \cdot 10^{-27} \text{ kg}) n V_p W$$

Here n is the average ion density and W is the ion atomic weight.

The primary issues which drive the sizing of the system are the time for radiation loss from the hot plasma (typically over 10,000K), and resistive decay time — both relative to the acceleration time of the plasmoid.

Radiation calculations are very complex and only crude estimates can be made here. Hopkins and Rawls (ref. 3) have produced analytical fits to the various radiation loss mechanisms. Figure 2 shows normalized radiation loss ψ for several elements. The total radiation loss, in W/m^3 , is given by

$$P_r = \psi n_e n_i$$

where n_e and n_i are the electron and ion density of the plasma, respectively. The characteristic radiation time is

$$\tau_r = \frac{E_{tot}}{P_r}$$

This time gives only a rough measure of the degree of loss through radiation. To do the problem right requires a detailed time-dependent analysis. However, it is useful in assessing feasibility. Note from Fig. 2 that radiation from hydrogen is well under that from the other elements. While it would be nice to use the more massive elements to raise thrust and lower specific impulse, it turns out that radiation loss precludes this option and hydrogen is the element of choice.

Since plasma temperatures are low in order to have high mass through high density for a given plasma pressure (otherwise, specific impulse is too high), only partial ionization occurs. Figure 3 shows ionization of hydrogen as a function of temperature and density (taken from ref. 4). At 1.5 eV and 10^{15} cm^{-3} total density, for example, hydrogen is about 50% ionized. Major concerns are the time required for this level of ionization to occur and the interaction of the ions with the remaining neutrals. These issues will be addressed in future work.

The other characteristic time of interest is the resistive decay time, which is the time it takes for the current in the plasma to dissipate due to the internal plasma resistance. If this is short compared to the acceleration time, ohmic dissipation will raise the plasma temperature and dissipate the current. The plasma β will increase to the point of disruption. It is not clear if this is a detriment since the plasma will

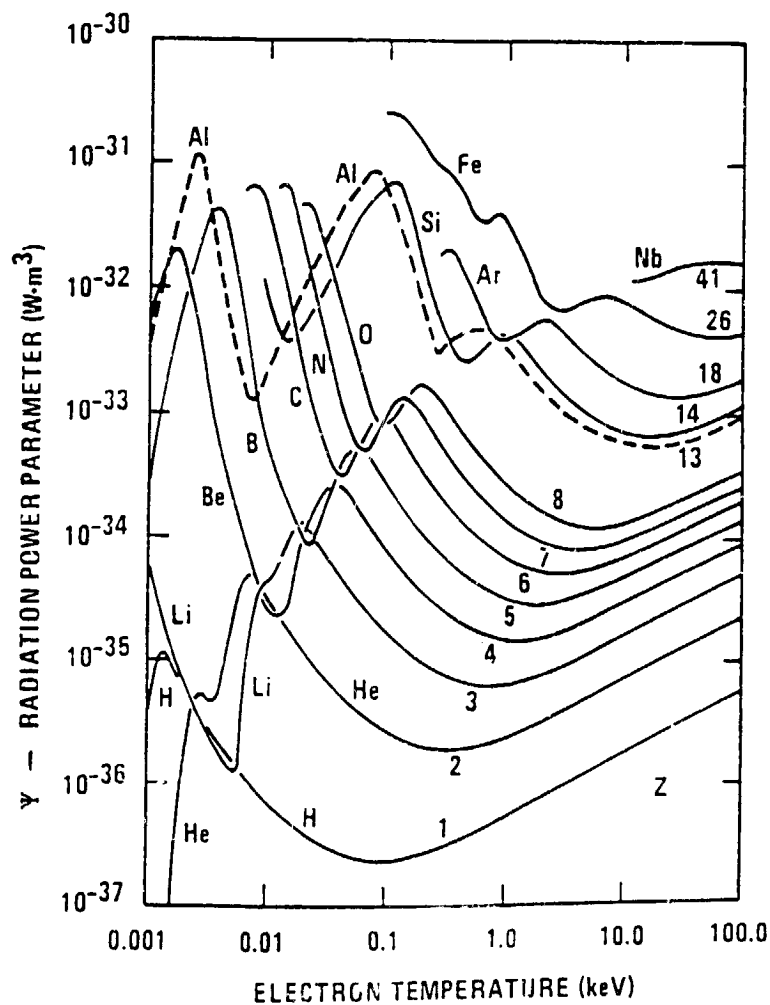

Fig. 2. Total radiation loss parameter as a function of plasma electron temperature. Coronal equilibrium is assumed (from ref. 3).

still expand down the nozzle converting its thermal energy to kinetic. And since, for a given expansion, a greater fraction of thermal energy is converted than magnetic, thrust efficiency could actually be higher. We will also explore this issue in follow-on work.

The full expression for plasma inductance is (ref. 5)

$$L = \mu_0 R \left[\ln \frac{8R}{a} - 2 + \frac{l_i}{2} \right] ,$$

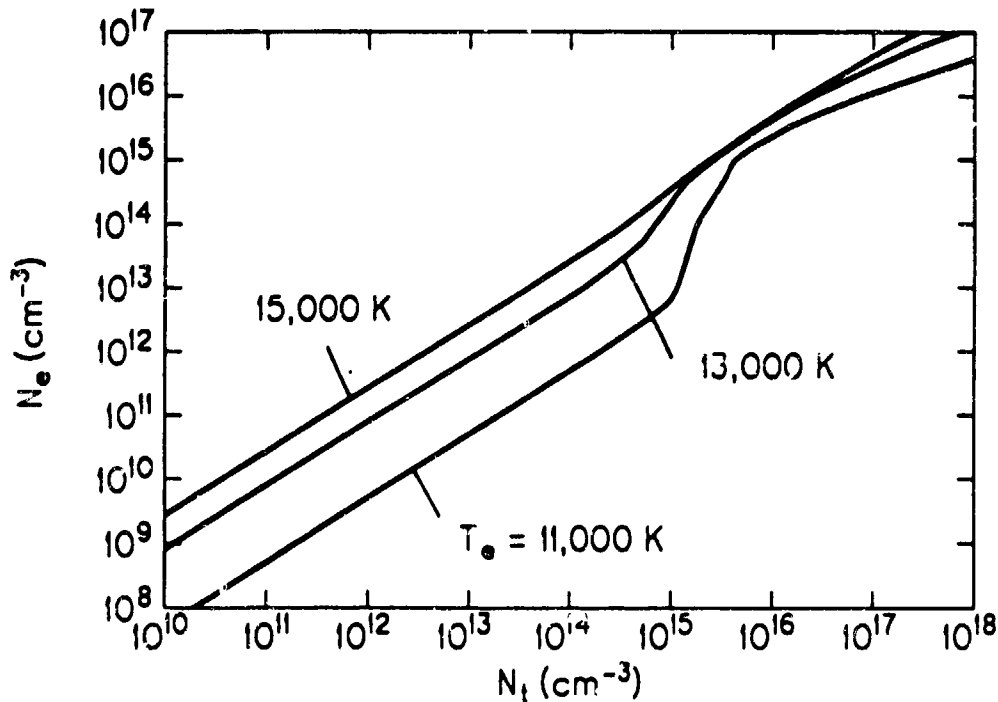

Fig. 3. Production of electrons in a hydrogen plasma as a function of particle density and electron temperature (from ref. 4).

where l_i is the plasma internal inductance. For uniform current profiles, which is likely here (due to turbulence), $l_i = 1/2$. With this and an aspect ratio $R/a = 1.5$, the bracket term is very nearly 1.6 and so $L \simeq \mu_0 R$.

The plasma resistivity is

$$\eta = 5.38 \cdot 10^{-5} \ln \Lambda Z T^{-1.5} ,$$

where Z is the atomic number of the gas and $\ln \Lambda$ is a constant that is typically about 16. The plasma total resistance, assuming flat temperature profiles and no resistivity enhancement due to turbulence or helical pitch of the current, is given by

$$\Omega = \eta \frac{2\pi R}{\pi a^2} .$$

The time for the current to decay to $1/e$ of its initial value is L/Ω .

The characteristic times above must be compared to the time to accelerate the plasmoid down the length of the nozzle. To limit radial kinetic energy the nozzle length L_n should be at least five times the outer radius of the plasmoid. Assuming constant acceleration, the time for acceleration is

$$\tau_{acc} = \frac{2 L_n}{u_e}$$

The above expressions are sufficient to perform an initial assessment of pulsed plasmoid propulsion. This is done below.

SCOPING CALCULATIONS

Using the above plasma equations along with some expressions for missions, a short code was written and exercised to determine operating parameter spaces. Two example cases are reported here. If time permits in the future, sensitivity studies could also be performed with this code.

Code output for a small thruster is shown in Table 1. Inputs 1 through 7, 10, and 13 define the plasma while Inputs 8, 9, and 12 refer to the mission. The power plant specific weight of 2 kg/kW is not unreasonable for an advanced nuclear electric plant or an advanced photovoltaic solar array (ref. 1). The radiation parameter of $7 \cdot 10^{-36}$ W-m³ is taken from Fig. 2 with hydrogen at 1.5 eV. Note that this temperature is used to establish the density at a given β . In actual fact, both temperature and β will float depending on the dynamics of the plasma power balance. That analysis is very complex and well beyond the scope of this effort.

With plasma current, β , temperature, field, and aspect ratio dictated, plasma dimensions, density, total mass and energy are determined from the equations discussed above. Also determined are the radiation loss and resistive decay times, the acceleration times, specific impulse and thrust. Using the mission input parameters, one can readily determine power plant and propellant mass, and a lower bound on acceleration time to the specified ΔV (it is an underestimate for guidance only because just the payload mass is considered).

The example in Table 1 is for a thruster that could be used to transfer the 1000 kg satellite from LEO to GEO in about 200 days. This is typical of electric propulsion missions and care is taken to protect delicate parts during the long spiral transit through the Van Allen radiation belts. With a specific impulse of 8000 sec and a thrust of 0.5 N, the total mass of propellant used is only 11.4% of the payload mass. Similarly, with an exhaust power of 20 kW, the power plant mass, here likely to be solar cells, is only 5% of the payload.

TABLE 1
SMALL HYDROGEN THRUSTER FOR ORBIT RAISING

<u>Input List</u>	
1 Plasma current, amps	0.10E+06
2 Poloidal beta	0.20
3 Plasma temperature, eV	1.50
4 Poloidal field, tesla	0.10
5 Aspect ratio, R/a	1.50
6 Ion atomic number	1.0
7 Ion atomic weight	1.00
8 Mission delta-V, m/sec	9000
9 Mission payload, kg	1000
10 Radiation parameter, $W\text{-m}^3$	0.70E-35
11 Electron density fraction	0.30
12 Power plant specific weight, kg/kW	2.0
13 Pulse frequency, Hz	10.0
<u>Output</u>	
Specific impulse, sec	8027
Thrust, N	0.515
Ratio of radiation to accel time	23.3
Plasma acceleration time, sec	0.636E-04
Radiation time, sec	0.149E-02
Propellant-to-payload mass ratio	0.114
Exhaust power, W	0.203E+05
Power plant mass, kg	0.507E+02
Ratio of power plant mass to payload	0.051
Total plasma energy, J	0.203E+04
Plasma thermal energy, J	0.141E+03
Plasma magnetic energy, J	0.188E+04
Plasma mass, kg	0.655E-06
Exhaust mass flow, kg/sec	0.655E-05
Ion density, m^{-3}	0.166E+22
Electron density, m^{-3}	0.497E+21
Plasma volume, m^3	0.236
Major radius, m	0.30
Plasma radius, m	0.20
Plasma o.d., m	1.0
Accelerator cone length, m	2.50
Plasma current resistive decay time, sec	0.536E-04
Spacecraft acceleration time, days	202

Considerable iterations were required to find a configuration that did not radiate excessively. It turned out that magnetic fields must be low, 0.1 T in this case, resulting in fairly large plasmas with low density. This is no surprise since radiation power density goes like n^2 . In this case, the radiation time is 23 times longer than the acceleration time, providing a comfortable margin to compensate for the crudeness of the calculation. The plasma L/Ω time of 53.6 μsec , however, is comparable to the acceleration time of 63.6 μsec . This suggests that some magnetic energy will convert to thermal, and then to kinetic, during the expansion. Clearly, detailed analysis of all this is needed, but it is very complex.

The overall plasma diameter of 1.0 m is quite large. However, although formation coils would have similar dimensions, their fields should be on the order of the magnetic field (0.1 T) and therefore would have fairly thin windings. The accelerator cone is 2.5 m long with an maximum diameter of perhaps 5 m. The forces on this cone are very small and so it could perhaps be made of very thin aluminum. Such a cone made of 10-mil thick aluminum would weigh about 60 kg (6% of payload) and could double as a heat radiator (more on this later).

A larger thruster, suitable for a manned Mars mission, is shown in Table 2. To increase thrust, plasma current is raised from 100 kA to 1.0 MA. Since thrust goes like I^3 , it increases from 0.5 to 515 N. Using 20 km/sec as a conservative ΔV for a Mars mission, a 200 tonne payload requires roughly 90 days worth of acceleration. Actually, it is longer because the propellant and power plant, each 25% as massive as the payload, must be added in as must other components discussed below.

A somewhat fanciful outline of such a spacecraft is shown in Fig. 4. As seen in Table 2, the plasma has a 10 m overall diameter and an accelerator length of 25 m. With a 5:1 expansion, the cone outer diameter is 50 m. This is acceptable only if it can serve multiple purposes. It turns out that it is just about the right size for the reject heat radiator for the nuclear reactor. The reactor power conversion is assumed to be a helium closed cycle gas turbine with a mean heat rejection temperature of 650K (1000K cooling to 300K). Assuming an emissivity of 0.8 and a 30% power conversion efficiency, then the 58 MW(th) reject heat can be radiated at roughly 8 kW/m². The total radiator area must then be around 7000 m². The above cone area is about 9000 m², just a little more than needed, which is fine because it allows for added heat input from plasma radiation (which is then radiated directly to space). If the specific weight of the nozzle can be held to 5 kg/m², its mass would be about 45,000 kg, which is an acceptable 22% of the payload mass.

There is no reason why the accelerator nozzle must be conical. It is only necessary that the plasma expansion be smooth. If instead it is made parabolic, then it may also be able to serve as a high-gain antenna. A swing-boom signal collector can be placed at the focus when the thruster is off. During the acceleration period from earth, the antenna is pointing properly to receive terrestrial signals.

TABLE 2
LARGE HYDROGEN THRUSTER FOR MARS MISSION

<u>Input List</u>	
1 Plasma current, amps	0.10E+07
2 Poloidal beta	0.20
3 Plasma temperature, eV	1.50
4 Poloidal field, tesla	0.10
5 Aspect ratio, R/a	1.50
6 Ion atomic number	1.0
7 Ion atomic weight	1.0
8 Mission delta-V, m/sec	20,000
9 Mission payload, kg	200,000
10 Radiation parameter, $W\cdot m^3$	0.70E-35
11 Electron density fraction	0.30
12 Power plant specific weight, kg/kW	2.0
13 Pulse frequency, Hz	10.0
<u>Output</u>	
Specific impulse, sec	8027
Thrust, N	515
Ratio of radiation to accel time	2.34
Plasma acceleration time, sec	0.636E-03
Radiation time, sec	0.149E-02
Propellant-to-payload mass ratio	0.254
Exhaust power, W	0.203E+08
Power plant mass, kg	0.507E+05
Ratio of power plant mass to payload	0.253
Total plasma energy, J	0.203E+07
Plasma thermal energy, J	0.141E+06
Plasma magnetic energy, J	0.188E+07
Plasma mass, kg	0.655E-03
Exhaust mass flow, kg/sec	0.655E-02
Ion density, m^{-3}	0.166E+22
Electron density, m^{-3}	0.497E+21
Plasma volume, m^3	236
Major radius, m	3.0
Plasma radius, m	2.0
Plasma o.d., m	10.0
Accelerator cone length, m	25.00
Plasma current resistive decay time, sec	0.536E-02
Spacecraft acceleration time, days	89.9

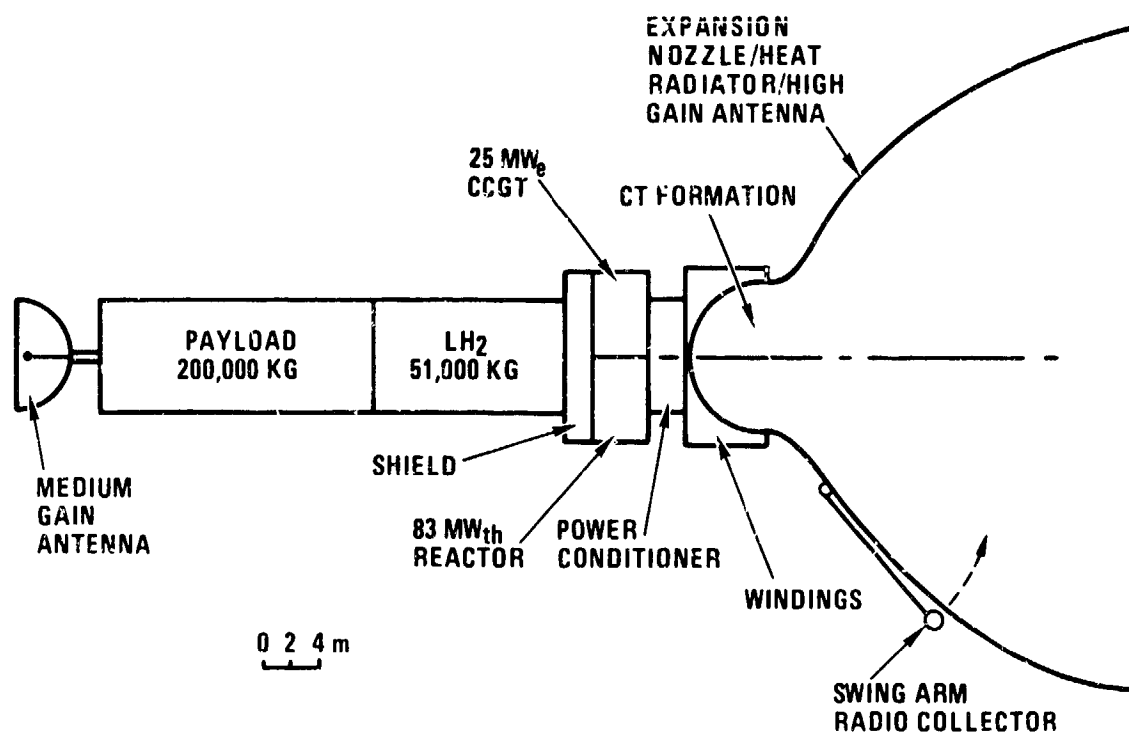

Fig. 4. Schematic of space station for manned Mars mission. Note that the large rocket nozzle serves multiple purposes.

DISCUSSION

The major attraction to this thruster is the potential for high thrust and high specific impulse and, if electrodes are not needed for formation, long lifetime. One would also expect the energy efficiency, which is the ratio of exhaust power to power supplied, to be quite high. In these respects, plasmoid propulsion appears to fill a gap in the arsenal of thrusters now available.

The main problems stem from radiation loss and the resulting large plasma dimensions needed to keep it in check and the partial ionization of the gas. The large size is compensated for by the low magnetic fields and low forces on the accelerator nozzle, permitting it to be made of thin-walled material. If the nozzle can in fact double as a heat radiator, then the large size is not a handicap.

There has been no discussion thus far of the power conditioning required. This is a pulsed system and high voltages with fast risetimes are required to form the plasma. In the case of the Mars thruster, total energies around 2 MJ must be supplied. If capacitors were used in this case, their mass would be roughly 40,000 kg, about 20% of the payload mass. This may actually be tolerable, although other pulsed energy sources

such as inductors should be explored as well. If the pulse frequency can be increased, the energy per pulse will drop, lowering not only the capacitor mass but the mass of the large accelerator cone. The 10 Hz chosen for the examples seemed reasonable from the standpoint of circuit recharging and chamber clearing. It can probably be much higher.

If one adds up all the major hardware for the Mars vehicle above, including the capacitors, one gets a mass roughly equal to the payload mass; *i.e.*, the payload fraction is 50% of the total initial mass, which would be very appealing for a Mars mission.

FUTURE WORK

The next step is to perform time-dependent plasma analyses and to scope out the design of the power conditioning system and plasma startup system. All of this is needed before an accurate estimate can be made of thrust efficiency, which is a very important number because it determines the size of the power plant needed.

REFERENCES

1. Jahn, R.G., *Principles of Electric Propulsion*, McGraw-Hill, New York, (1968).
2. Stone, J.R., and Bennett, G.L., "The NASA Low Thrust Propulsion Program," AIAA Paper 89-2492 (July 1989).
3. Hopkins, G.R., and Rawls, J.R., "Addendum to Impurity Radiation From Medium Density Plasmas," General Atomics Report GA-A14241 Addendum (October 1977).
4. Kunc, J.A., and Soon, W.H., "Radiation of Hot Hydrogen," AIAA Paper 89-2598 (July 1989).
5. Schaffer, M., General Atomics, personal communication, February 1988.
6. Stella, P., and Kurland, R., "APSA — A New Generation of Photovoltaic Solar Arrays," AIAA Paper 89-2271 (July 1989).