

N91-22173

**A HYDROPONIC DESIGN FOR MICROGRAVITY
AND GRAVITY INSTALLATIONS**

Judith Fielder and Nickolaus Leggett
Reston, Virginia

A hydroponic system is presented that is designed for use in microgravity or gravity environments. The system utilizes a sponge-like growing medium installed in tubular modules. The modules contain the plant roots and manage the flow of nutrient solution. The physical design and materials considerations are discussed as are modifications of the basic design for use in microgravity or gravity environments. The major external environmental requirements are also presented.

INTRODUCTION

This paper presents a design for a hydroponic system capable of supporting plant growth from seed through maturity. This system can operate in either microgravity or lunar/planetary base environments with only minor modifications required to transition between these environments.

The hydroponic system provides a dark, moist, nutrient-rich, well-aerated environment that is suited for the growth of plant roots. A supporting medium holds the seeds and growing plants which have access to a lighted external environment. In addition, containment is provided to keep solution flows under control in a microgravity environment.

PHYSICAL DESIGN

The basic hydroponic design consists of tubular structures of sufficient size to accommodate the types of plants being grown. Each tubular structure is a cylindrical module with an open slit extending for the majority of the length of the cylinder. This open slit accommodates a sandwich of a foam-like, spongy substance that holds seeds or growing plants. The slit is oriented towards the lighting system.

The sandwich consists of two strips of spongy material that are inserted into the open slit to fill the entire length of the slit in the cylinder. Crop seeds or plants are placed between the two layers. The portion of the strips exposed to the light is coated with an impermeable, opaque coating.

The tubular structures are installed in arrays that make optimum use of the lighting system and the available pressurized volume. Each tube is connected to a nutrient solution feed line and a nutrient solution removal line. Both the feed and removal lines have valves and bypass lines so that individual modules can be taken out of service without disrupting the operation of the entire growing system.

NUTRIENT FLOWS

In the microgravity configuration, the nutrient solution feed system is a flattened pressurized feed line inserted near the surface of each strip of sponge. (Fig. 1) A pressurized flow of aerated nutrient solution is introduced into the

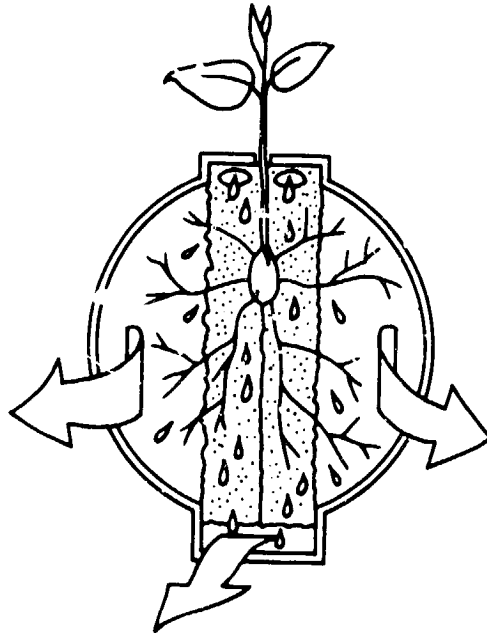

Figure 1. Microgravity system configuration.

sponge strips. The flow is directed away from the exterior towards the "bottom" of the cylinder. This flow is maintained and reinforced by a longitudinal air flow established within the cylinder and by the removal of excess and spent nutrient solution by a suction system. (Fig. 2) In a microgravity environment this pressurized flow of nutrient solution may aid in orienting root growth towards the interior of the cylinder. What roots do grow into the exterior will likely be air-pruned into directionality.

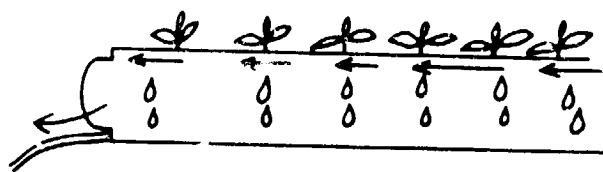

Figure 2. Nutrient flow in microgravity.

In the gravity environment, the nutrient solution is introduced into the cylinder in an ebb and flow schedule. The cylinder is allowed to fill with nutrient solution and then the nutrient solution is drained away. (Fig. 3). This ebb and

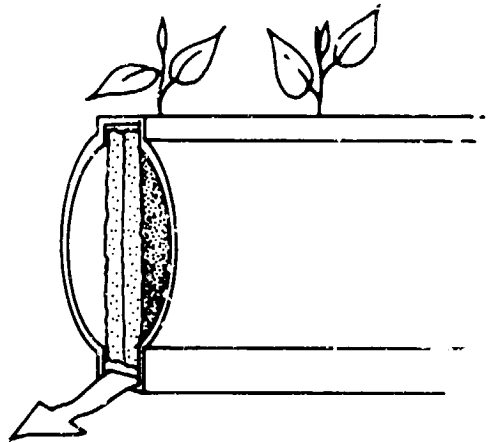

Figure 3. Nutrient flow in gravity.

flow cycling ensures that the roots are well aerated in addition to being supplied with nutrient solution. The ebb and flow cycles are more frequent during periods when the plants are lighted and transpiration is at a peak than during the dark periods.

NUTRIENT MANAGEMENT AND CONTROLS

The nutrient solutions used in this system must contain all macro nutrients and micronutrients required for plant germination, growth, and maturation. The solutions will need to be formulated for individual crop types to ensure optimum growth rates and yields.

Hydroponic systems tend to be unforgiving of failures in nutrient flows. This system partially mitigates this problem with the limited nutrient solution holding capacity of the sponge. Redundant reservoirs of pre-mixed nutrient solution will be required to replace the existing nutrient solution system reservoir should it become contaminated or lost.

Periodic sterilization of the circulating nutrient solution is recommended to control pathogens. In-line filters will limit the movement of plant materials and some types of pathogens through the system. Plant toxins, pH, and soluble solids must be monitored on a continuous basis.

The circulating nutrient solution must be refreshed and periodically replaced in entirety. Provision should be made for the reconstituting of the spent nutrient solution and for the recycling of organic wastes. These major requirements are not easily achieved in a hydroponic system.

EXTERNAL ENVIRONMENT

The environment outside of the cylinder should replicate many of the features of the earth's environment. The plants should be fully and evenly lit

with light provided in a regulated day/night cycle. Broad spectrum lighting in the 400 to 800 nanometer range is required with infrared emissions kept to a minimum. The light intensity should be 200 to 400 watts per square meter for optimum plant response. This lighting system will generate waste heat that must be removed from the agricultural area.

Temperature in the agricultural areas should be maintained in the range of 15°C to 32°C. A standard nitrogen, oxygen, and carbon dioxide atmosphere is required. A pressure of 800 mb or above is strongly recommended. This atmosphere is intermittently moved by the plants at a speed of 1-6 km/hour to circulate fresh air, prevent CO₂ depletion, facilitate temperature control, and provide some thigmonastical stimulation.

The plants may need other environmental features such as the presence of a steady state magnetic field. The exploration of these features should be an important mission for space station and lunar base plant growth experiments.

MATERIALS ENGINEERING CONSIDERATIONS

All materials used in this system must be non-toxic to both plants and crew members. This includes the cylinders, sponge strips, feed lines, valves, circulating pumps, and other components that come in contact with the plants or the nutrient solution. Coated toxic materials are not appropriate due to the possibility of coating failure either by accidental impact or abrasion.

The foam-like sponge strips must be engineered for appropriate water retention and aeration properties required by their gravity environment. It would be advantageous to create the sponge out of a recyclable material that does not have to be imported from the earth.

All of the materials in contact with the plants and nutrient solutions must be highly resistant to corrosion. There should be little or no interaction between the materials, nutrient solutions, plant-released organic acids, and other compounds. Aluminum components in particular should be avoided because of their corrosion susceptibility and toxicity to plants.

NATURAL VACUUM ELECTRONICS

Nickolaus E. Leggett
Reston, VA

The ambient natural vacuum of space is proposed as a basis for electron valves. Each valve is an electron-controlling structure similar to a vacuum tube that is operated without a vacuum sustaining envelope.

The natural vacuum electron valves discussed offer a viable substitute for solid state devices. The natural vacuum valve is highly resistant to ionizing radiation, system generated electromagnetic pulse, current transients, and direct exposure to space conditions.

INTRODUCTION

This paper proposes the use of the natural vacuum of space as a basis for electronic components. The space environment offers a natural vacuum that is suitable for the passage of electron beams over rather long distances. These electron beams can be used in electron valve components.

PHYSICAL OPERATION

The basic natural vacuum component uses a stream of electrons that is emitted from a source. This electron stream travels through the ambient vacuum environment towards a positively charged destination. This basic flow corresponds to the flow of electrons within the diode vacuum tube of electronics history. In the diode vacuum tube, electrons are emitted by a heated cathode (thermionic emission). The emitted electrons are attracted across the vacuum by a positively charged metallic plate (the anode).

Natural vacuum components use this basic vacuum tube flow without the need for the vacuum sustaining enclosure. The cathode and anode are directly exposed to the ambient environment of space. The natural vacuum diode "tube" provides the service of rectification where an alternating current input is converted to pulses of direct current output.

Additional functions are provided by installing electron flow modifying structures in the electron beam. A metallic screen or grid placed in the electron beam between the cathode and anode provides a valving action. Varying the electric charge on the grid varies the electron beam current traveling between the cathode and the anode. Additional grids can be inserted into the electron flow to provide additional control and to isolate against undesired coupling of stray signals through the system.

This type of valving is quite familiar to people in electronics who have worked with multi-grid vacuum tubes. In the multigrid natural vacuum component, the artificial vacuum, maintained by the glass tube is replaced by the ambient environment of space. Figure 1 shows a natural vacuum component with concentric grids.

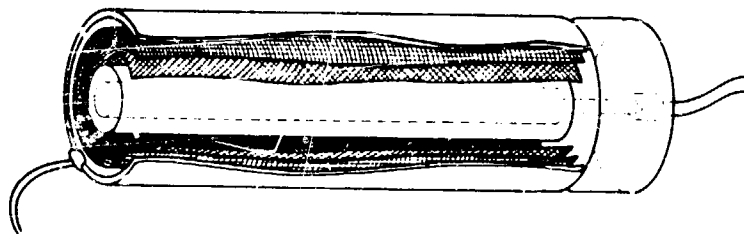

Figure 1. Natural vacuum component.

Magnetic fields can be used to control the electron beam also. Magnetic fields can direct, deflect, reverse, or contain the electron beam. A limited example of this control is the common television picture tube. The ambient environment of space frees the natural vacuum component from the heavy picture tube containment. A natural vacuum component can hang the electron gun and magnetic coils in an open structure.

COMPONENT INNOVATIONS

Natural vacuum components are not limited to revivals of older vacuum tube designs. The large volume of the ambient space environment allows the component designer to produce components that are not practical in small artificial vacuum tube environments. For example, the grids within a natural vacuum component can be mechanically deployable. Different sets of grids can be deployed for different operating conditions.

The cathode can be heated by directly focused solar energy. This configuration avoids the problem of filament failure that was a common problem with terrestrial vacuum tubes.

The most profitable approach to natural vacuum electronics is to think of the ambient environment of space as a gymnasium for electrons. You can place electron sources, destinations (anodes), and beam modifying devices where you need them within the ambient environment. Your design does not have to be limited to connected electron-valving modules. A continuous structure can perform operations on a continuous electron beam that passes through the structure. Connections between the stages of processing are provided by the electron beam itself (although a "ground" return conductor is required as well).

NON-ELECTRON CARRIERS

The natural vacuum approach can use carriers other than electrons. For example, accelerator technology can be used to generate streams of protons to

carry signals or power. While protons may not have clearly-visible advantages over electrons, it is worthwhile to examine the concept of proton-based circuits.

One possible advantage of proton-based circuits is that protons are heavier than electrons. Thus a beam of protons would be less perturbed by ambient magnetic fields—a possible advantage in some space environments.

Atomic nuclei can also be used in natural vacuum systems. Similarly, larger masses of material can be pushed about by mass driver and magnetic separator types of "circuit" components. The scope of electronics is expanded to a continuum of natural vacuum functions that includes large scale energy beam manipulation and materials separation and processing.

USES

The basic natural vacuum components provide the familiar active electronics functions of:

- switching
- rectification
- oscillation
- amplification
- detection
- mixing

These are the same functions provided by transistors or vacuum tubes. The natural vacuum component is a very robust replacement for conventional solid-state components. Entire electronic circuits can be built from natural vacuum components or natural vacuum components can be used in conjunction with conventional components.

ADVANTAGES

Natural vacuum components are very robust devices that can survive the stresses of the space environment. Each natural vacuum component is a largely open-metal structure that is directly exposed to the vacuum environment. This structure is resistant to damage from ionizing radiation, system generated electromagnetic pulse (SGEMP), and micro-particle impacts.

The natural vacuum components can be installed outside of the spacecraft conserving interior space for other uses. (Fig. 2) These components can be operated at very high power levels when suitable radiative cooling means are provided.

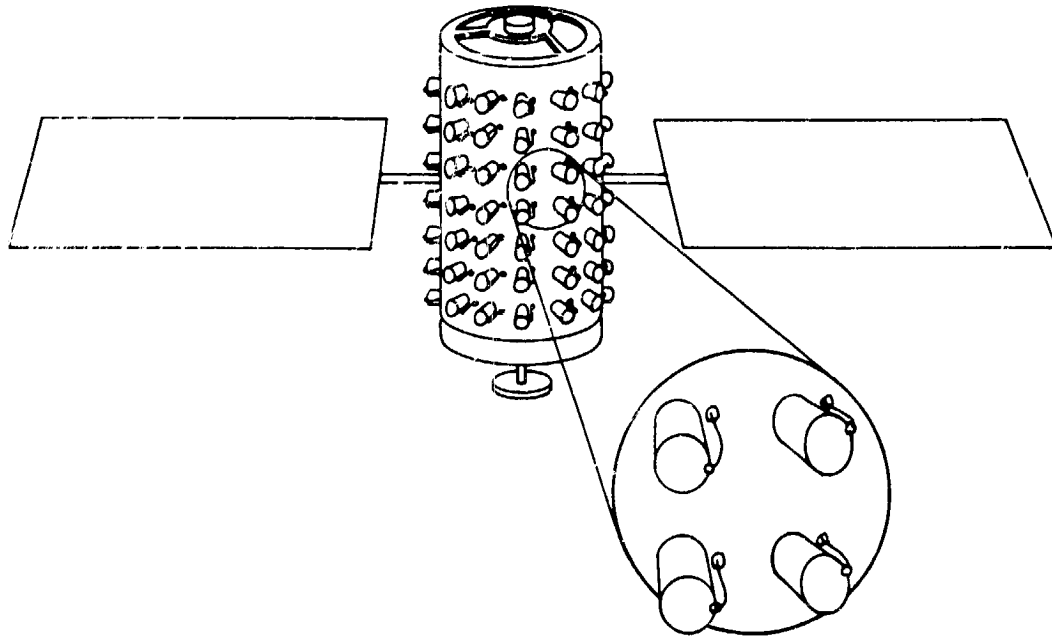

Figure 2. Configuration of externally mounted components.

The natural vacuum components can be made from space-derived metals and insulating materials, when these materials become available. This increases the appeal of the natural vacuum approach for worlds such as the moon that have excellent ambient vacuum environments and locally available materials.

DISADVANTAGES

The operation of natural vacuum components could be negatively impacted by the poor quality of "vacuum" present in low earth orbit or near other bodies with atmospheres. One such impact is the blockage of the free flow of electrons. Erosion of the components due to the action of ambient molecules could occur as well.

Another potential problem is the size and weight of natural vacuum components that may be larger than their solid state equivalents.

CONCLUSION

Natural vacuum components should be considered for space craft and lunar base designs. These components change the vacuum of space from a problem into an asset.