

Earth Observing System

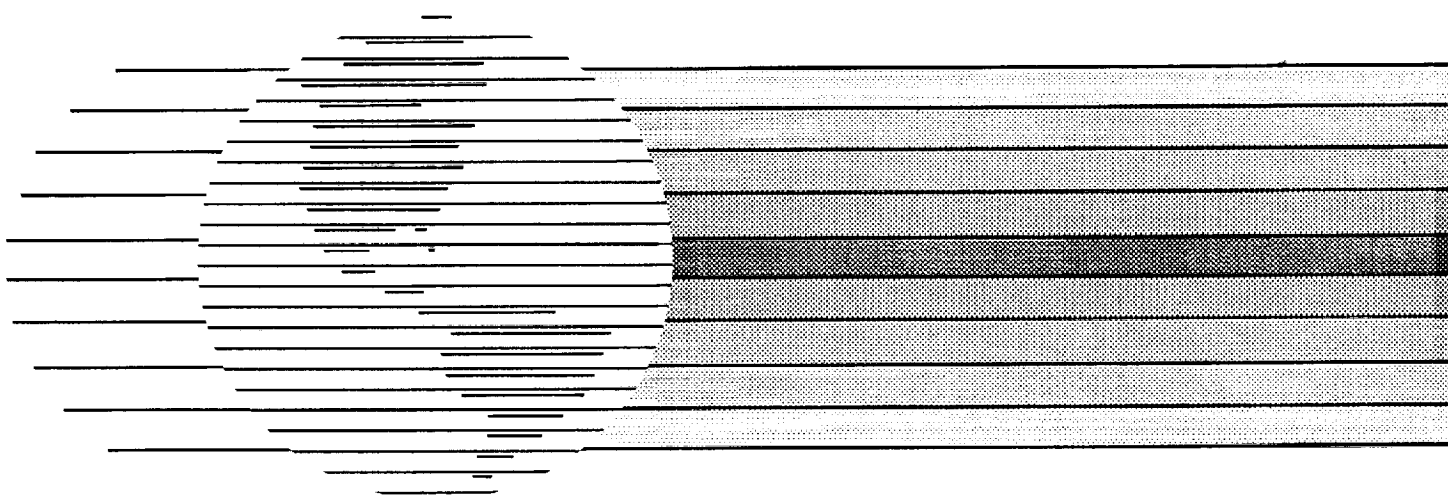

1989 Reference Handbook

(NASA-TM-104948) EARTH OBSERVING SYSTEM:
1989 REFERENCE HANDBOOK (NASA) 68 p

CSCL 22B

N91-22353

Unclas

G3/18 0008354



National Aeronautics and
Space Administration

Goddard Space Flight Center

7

1945

CONTENTS

Mission To Planet Earth -- The Earth Observing System	2
Major Milestones	3
Mission Objectives	4
Science Goals	5
Eos Data And Information System	6
NASA Polar Orbiting Platforms	8
Eos Fact Sheet	10
Facility Instruments And Teams	11
Instrument Investigations	27
Interdisciplinary Investigations	53

This handbook is meant to serve as a reference giving names, acronyms, and numbers of which there are so many. This is the second printing of the Handbook, to meet strong demand for information concerning Eos-B. Due to tight printing deadlines, only typographical errors and minor edit changes were possible. More comprehensive changes to text and diagrams will be completed before the final printing in Summer 1989.

May 1989

MISSION TO PLANET EARTH -- THE EARTH OBSERVING SYSTEM

NASA is studying a coordinated effort called Mission To Planet Earth to study and understand global change. The goals are to understand the Earth as a system, and to determine those processes that contribute to our environmental balance, as well as those that may result in change. We strive towards developing the capability to make reliable predictions.

We have a good deal of evidence of change, due both to natural variability and from the results of human technological activity. It becomes important to determine the extent of these changes and their processes. Since some global resources may be under stress, there is a degree of urgency to our work. Science is now capable of dealing with the issue: we are beginning to understand the importance of the interdisciplinary aspects, we have many of the advanced tools needed for making the observations, and we have the technology to handle the vast quantities of data needed for constructing the models necessary for understanding the processes.

The heterogeneity and restless character of the Earth and the rate of change of its processes require that many measurements can be made only by synoptic observations over a long period of time. The complexity of the problem requires the combined efforts of scientists of many disciplines and from many nations.

The Earth Observing System (Eos) is the centerpiece of the program. It is an international, coordinated effort that combines the observational instrumentation with the scientific power to produce a significant part of the database underlying Mission to Planet Earth. The ideas for Eos have heritage in other work, other studies, and other missions by NASA, NOAA, and other nations besides the United States.

Eos cannot do everything, but it will be the most significant unifying effort of its time to understand the Earth as a planet.

MAJOR MILESTONES

1989	June 5-16	Non-Advocacy Review (NAR)
	June 15	Initiation of Investigations (Start of Definition-Phase Contracts)
1990	February	Instrument Execution-Phase Conceptual Design and Cost Reviews
	March	Interdisciplinary Investigation Performance Reviews
	September	Final Selection of Instruments for First NASA-Supplied Platform Payload; Confirmation of All Other Definition-Phase Selections
1991	January	Initiation of Payload Execution Phase
1995	January	Delivery of Instruments to NASA for Integration on First NASA-Supplied Polar Platform
1996	December	Earliest Possible Launch of First NASA-Supplied Platform
1997	January	Delivery of Instruments to NASA for Integration on Second NASA-Supplied Platform
1997	March	Launch of ESA-Supplied Platform A
1995-1997		Launch of Instruments as Attached Payloads on the Manned Space Station
1998	December	Earliest Possible Launch of Second NASA-Supplied Platform
1998		Launch of Japanese-Supplied Platform
2000		Launch of ESA Supplied Platform B

MISSION OBJECTIVES

Eos is a science mission whose goal is to advance the understanding of the entire Earth system on the global scale through developing a deeper understanding of the components of that system, the interactions among them, and how the Earth system is changing. The Eos mission will create an integrated scientific observing

system that will enable multidisciplinary study of the Earth including the atmosphere, oceans, land surface, polar regions, and solid Earth. In order to quantify changes in the Earth system, Eos will be a long-term mission providing systematic, continuing observations from low Earth orbit.

More specific mission objectives are:

- (1) To develop a comprehensive data and information system including a data retrieval and processing system to serve the needs of scientists performing an integrated multidisciplinary study of planet Earth.
 - dynamics of the land surface, including terrestrial and inland water ecosystems;
 - The rates, important sources and sinks, and key components and processes of the Earth's biogeochemical cycles;
- (2) To acquire and assemble a global data base emphasizing remote sensing measurements from space over a decade or more to enable definitive and conclusive studies of aspects of Earth system science including:
 - The global distribution of energy input to and energy output from the Earth;
 - The structure, state variables, composition, and dynamics of the atmosphere from the ground to the mesopause;
 - The physical and biological structure, state, composition, and
 - The circulation, surface temperature, wind stress and sea state, and the biological activity of the oceans;
 - The extent, type, state, elevation, roughness, and dynamics of glaciers, ice sheets, snow, and sea ice and the liquid water equivalent of snow;
 - The global rates, amounts, and distribution of precipitation;
 - The dynamic motions of the Earth as a whole, including both rotational dynamics and the kinematic motions of the tectonic plates.

SCIENCE GOALS

The fundamental processes which govern and integrate the Earth system are the hydrologic cycle, the biogeochemical cycles, climatological and geophysical processes. Each of these includes physical, chemical, and biological phenomena. As an example of the need for an interdisciplinary approach, there is the potential for climate change related to the increase in atmospheric carbon dioxide and the increased release of ozone-destroying gases, which can also affect climate. Atmospheric responses to consequent changes in global heating can be reflected as changes in the global hydrologic cycle. All of these changes will impact on the biosphere.

Thus, Eos recognizes the need to advance man's knowledge in each of the fundamental processes. To support this requirement for knowledge of the fundamental processes, Eos will undertake space-supported investigations of the atmosphere, biosphere, hydrosphere, cryosphere, and the solid Earth. These investigations will include development and operation of remote-sensing instruments and the conduct of interdisciplinary investigations using data from these instruments.

Just a few examples of potential Eos research areas are given below.

Hydrologic Cycle:

- Determine the effects of sea and land ice upon the global hydrologic cycle.
- Quantify the interactions between the vegetation, soil, and topographic characteristics of the land surface and the components of the hydrologic cycle.

Biogeochemical Cycles:

- Determine the global distribution of biomass and what controls both its heterogeneous distribution in space and its change over time.
- Quantify the global distribution and transport of tropospheric gases and aerosols and determine the strengths of their sources and sinks in the ocean, land surface, coastal and inland waters, and upper atmosphere.

Climatological Processes:

- Quantify the modes of large-scale and low-frequency variability of meteorological variables such as wind, pressure, temperature, cloudiness, and precipitation.
- Determine the role of land biota as sources and/or sinks of carbon dioxide and other radiatively important trace gases.

Geophysical Processes:

- Understand the interaction of physical and biological processes in the ocean, including the effects of horizontal and vertical variability.
- Understand how episodic processes such as rainfall, runoff, dust storms, earthquakes, and volcanism modify the surface of the Earth.

Eos DATA AND INFORMATION SYSTEM

The Eos Data and Information System (EosDIS) will provide access to data from the Eos instruments and to the scientific results of research using these data. The EosDIS is to be

a complete research information system that incorporates traditional mission data system facilities, but includes on-line electronic access to Eos data for all Earth science researchers.

Key functional objectives for the overall EosDIS system include:

- Providing a unified and simplified means for obtaining Earth science data
- Providing prompt access to all levels of data and documentation concerning the processing algorithms and validation of the data, and to data sets and documentation that result from research and analyses conducted using the data provided by Eos
- Enabling a distributed community of Earth scientists to interact with data sources
- and mission operations from their own labs
- Providing a retrieval system and science user interface that is responsive to user needs
- Providing a capability for evolution and growth and for adaptation to new sources of data and new data system technologies.

EosDIS operations responsibilities fall into two general categories: Eos flight operations and Eos science data operations. Eos flight operations functions include command and control of the Eos payloads as well as monitoring their health and safety.

There will be an onboard data system to collect data from the instrument/space element systems and package the data for transmission to ground.

The Eos science data operations functions include processing, archiving, distributing, and managing all Eos-generated data including maintaining directories, catalogs, inventories, and other information about Eos and ancillary data.

The EosDIS will provide three classes of data: 1) processed instrument data, 2) relevant in situ data and other data used for algorithm development and calibration, and 3) output data resulting from EosDIS studies.

EosDIS Acronym List

ANC	Ancillary Data	ISTs	Instrument Support Terminals
CDA	Command and Data Acquisition	L	Data Level
CMDS	Commands	MMOC	Multimission Operations Center
D/L	Downlink	NCC	Network Control Center
DADS	Data Archive and Distribution System	P/S	Planning/Scheduling
DHC	Data Handling Center	P/F	Platform
DIF	Data Interface Facility	PICF	Principal Investigator Computing Facility
Eos	Earth Observing System	PSC	Platform Support Center
EMOC	Eos Mission Operations Center	RICC	Remote Instrument Control Center
EosDIS	Eos Data Information System	TDRSS	Tracking and Data Relay Satellite System
FDF	Flight Dynamics Facility	TGT	TDRS Ground Terminal
GPS	Global Positioning System	TMCF	Team Member Computing Facility
ICC	Instrument Control Center	U/L	Uplink
IICF	Interdisciplinary Investigator Computing Facility		

PRELIMINARY EosDIS CONCEPT DIAGRAM

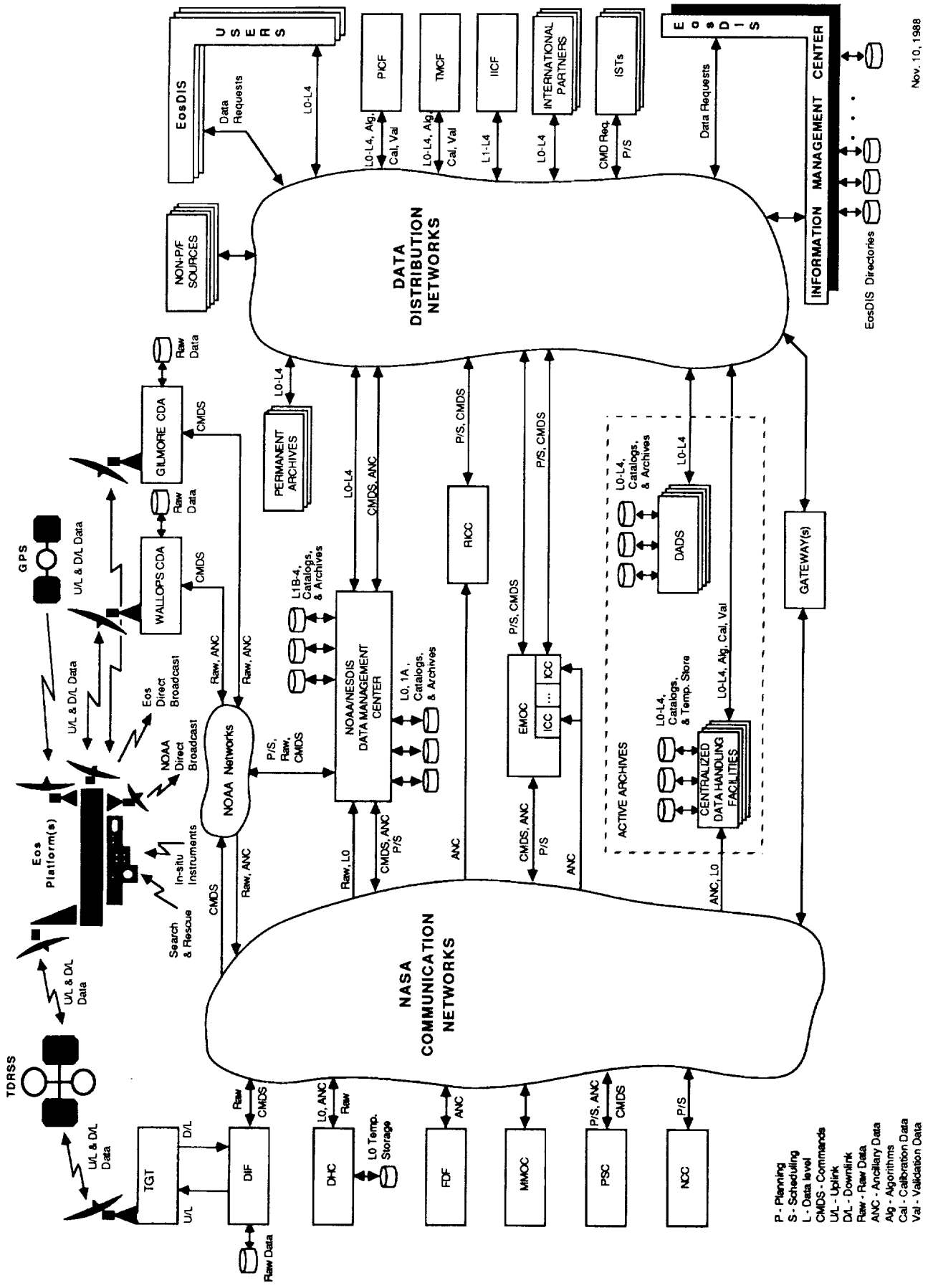

NASA POLAR ORBITING PLATFORM Eos-A (NPOP-1)

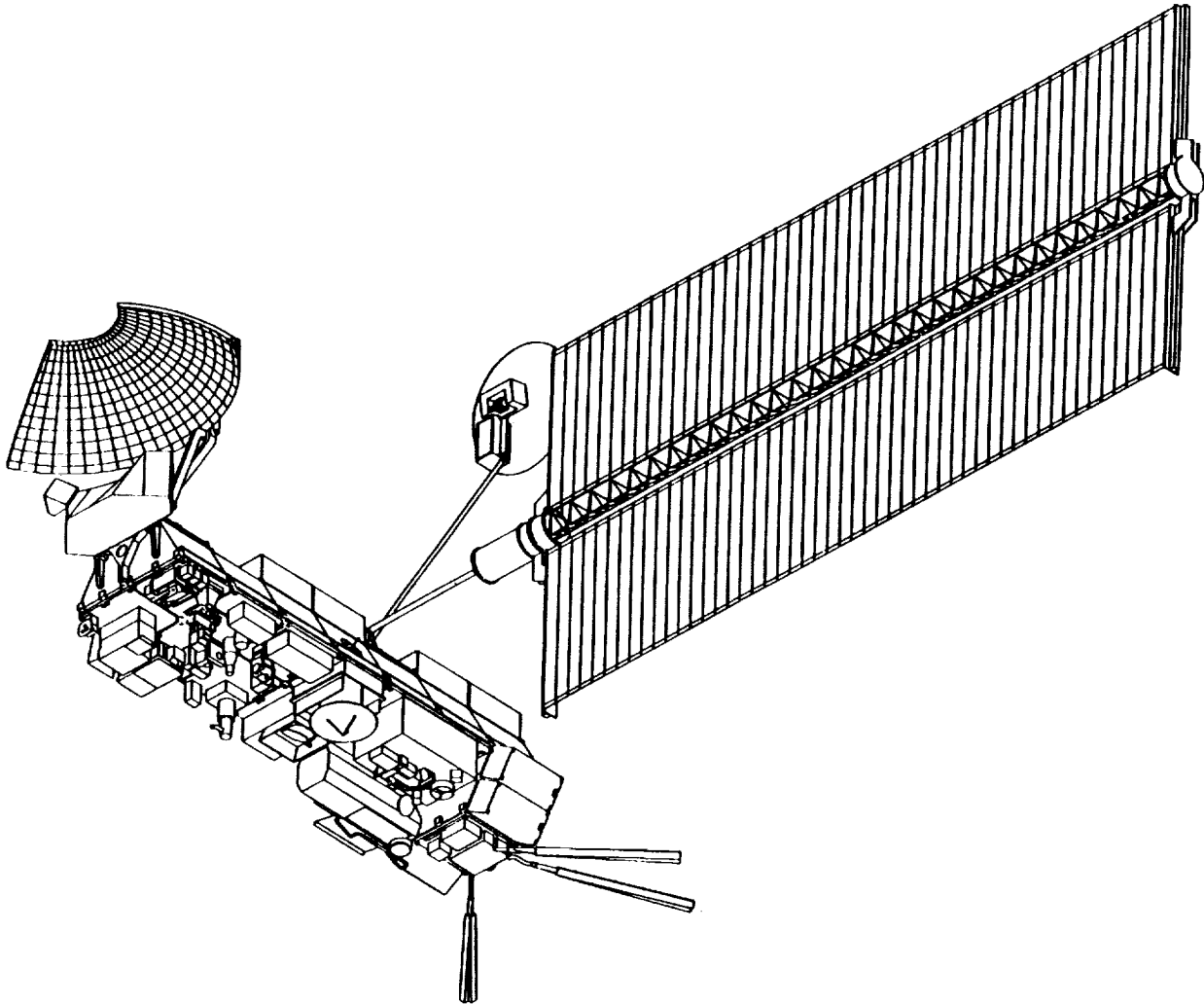

This is one design concept for Eos-A, which will utilize the polar platform of the Space Station Freedom Program. The platform is shown with the boom mounted TDRSS antenna and the asymmetric solar panel configuration. The platform will carry an instrument complement consisting of Principal Investigator selected instruments, facility instruments, and international contributions together with certain spacecraft-unique equipment. Shown in the picture is a test case instrument complement.

The large structure shown mounted on the velocity end is AMSR (Advanced Microwave Scanning Radiometer), a proposed contribution from Japan. Also mounted on the forward end is a conventional six stick scatterometer. A TOPEX

class altimeter antenna is shown at the opposite end of the payload mounting surface together with HIRIS (High Resolution Imaging Spectrometer). Instruments such as MODIS (Moderate Resolution Imaging Spectrometer), CR (Correlation Radiometer), IR-rad (Infrared Radiometer), MPD (Magnetospheric Particle Detectors), and other representative Principal Investigator Instruments are distributed on the payload mounting area. The polar platform will be approximately 55 ft. (16 m) long and 15 ft. (4 m) wide and will weigh 30,000 lbs. (13,600 kg). The platform(s) will fly in a sun-synchronous orbit at approximately 705 km (LANDSAT orbit) and will be phased with the Eos-B observatory to provide synergistic measurements between HIRIS and SAR.

NASA POLAR ORBITING PLATFORM Eos-B (NPOP-2)

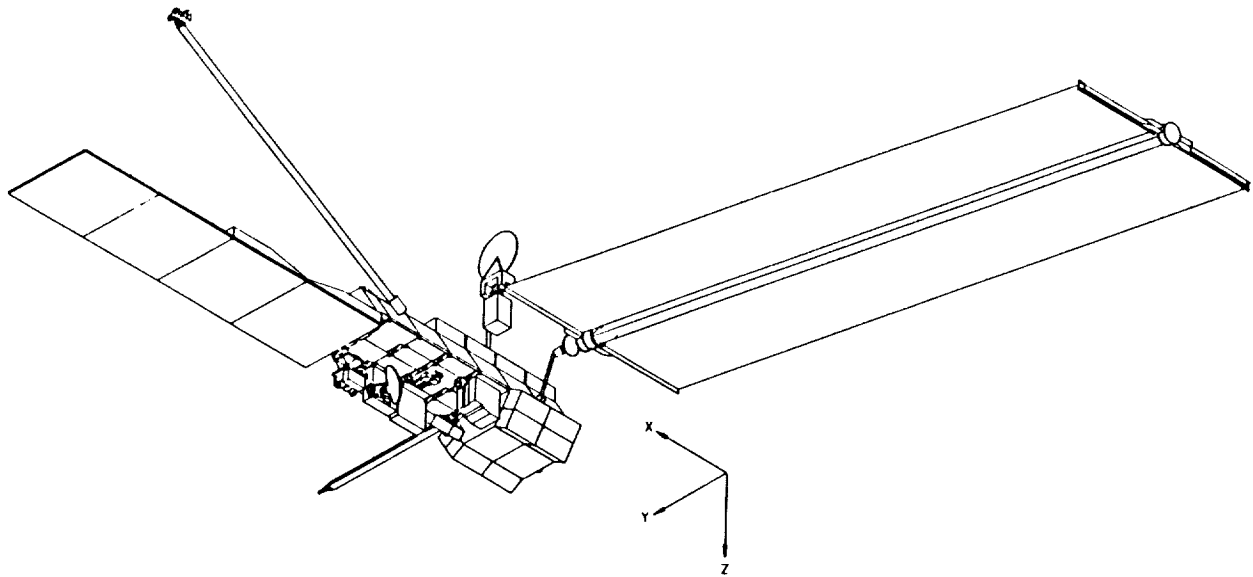

This is a preliminary design concept for Eos-B. This platform carries a Synthetic Aperture Radar (SAR), three upper atmospheric instruments (MLS, SAFIRE, and SWIRLS), one tropospheric instrument (TES), and a collection of particles and fields experiments (GOS, IPEI, SEM, and XIE). Also located on Eos-B is the GGI, which will be used as a precision orbit determination system. SAR is the large, four-panelled antenna mounted on the forward part of the spacecraft, where it can be rotated to view either to the right or to the left

of the spacecraft ground track. The atmospheric instruments are located on the nadir face. The two booms extending from the spacecraft carry the particles and fields experiments: the lower boom a magnetometer, the upper boom a large fraction of the remaining instruments. The Tracking and Data Relay System (TDRS) antenna can also be seen, although it is partially hidden by the solar array, which extends to the right. For reference, x is the velocity vector, z is nadir.

Eos FACT SHEET

Spacecraft Orbits

Polar platform(s) will be in sun-synchronous orbits at 705 km: Eos-1-NASA has a 1:30 p.m. equator crossing time, ascending node; Eos-ESA has a

10:00 a.m. equator crossing time, descending node. Space Station has a 28.5° inclination orbit at 335 to 460 km.

NASA Polar Platform Parameters

Payload Mass	3500 kg
Power (average to payload)	3.2 kW
Data Relay via TDRSS	300 Mbps maximum data rate
Data Recording Rate	300 Mbps maximum
Onboard Data Storage Capacity	10^{12} bits
Playback Data Rate	300 Mbps maximum
Direct Downlink Maximum Data Rate	100 Mbps
Command Uplink Rate	100 kbps
Pointing Accuracy	270 arcsec
Pointing Knowledge	90 arcsec
Pointing Stability	10 arcsec/sec

ESA Polar Platform Parameters

Payload Mass	2500 to 2600 kg
Power (average to payload)	4.0 kW (daylight)
Data Links for Payload	300 Mbps maximum data rate
- TDRS Link or	300 Mbps maximum
- EDRS Link and	500 Mbps maximum
- simultaneously	
X-Bank Direct Link	200 Mbps
Data Recording Rate	10 Mbps
Onboard Data Storage Capacity	3×10^{10} bits
Playback Data Rate	50 Mbps
Onboard Local Area Net Capacity	1 Mbps individual instrument, 5 Mbps total payload complement
Command Uplink Rate	100 kbps
Pointing Stability	0.07° in 270 sec time window
Pointing Knowledge	0.03°
Ground Track Stability	± 1 km (crosstrack)

FACILITY INSTRUMENTS AND TEAMS

MODIS-T/-N
AIRS
HIRIS
SAR
GLRS
LAWS
AMSU-A
AMSU-B
ALT
ITIR
AMSR
MERIS
HRIS
ATLID

Moderate-Resolution Imaging Spectrometer-T/-N

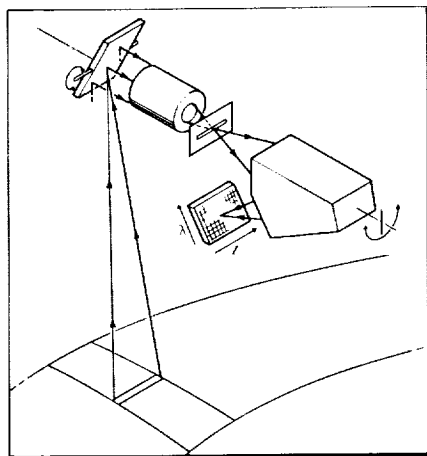

MODIS-T is an imaging spectrometer for the measurement of biological and physical processes on a 1 km x 1 km scale with emphasis on the study of ocean primary productivity. It is a scanning instrument covering an 1,500 km swath centered at nadir, with a $\pm 50^\circ$ tilt capability for sun-glint avoidance and the examination of the bidirectional reflectance distribution function

(BRDF) of large homogeneous targets. It has a spectral range of 0.4 to 1.04 μm divided into 64 bands.

MODIS-T has a mass of approximately 100 kg, a data rate of 9 Mbps, and requires 200 watts of power. MODIS-T is baselined for the Eos-A polar platform.

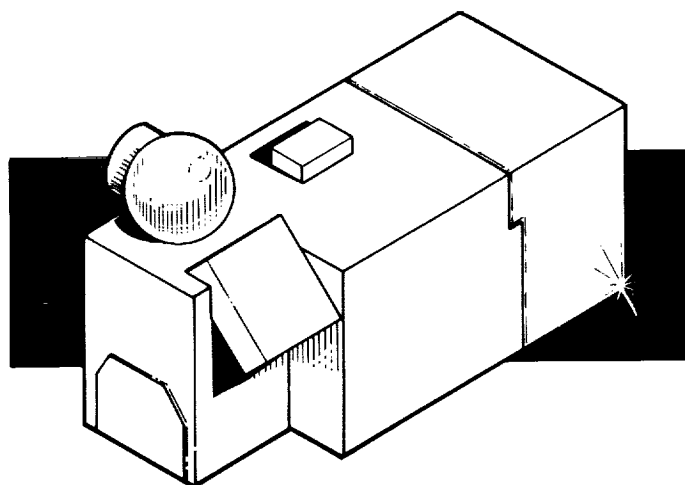

MODIS-N is a companion instrument to MODIS-T and is an imaging spectrometer used for the measurement of biological and physical processes which do not require off-nadir, fore and aft pointing. It has pixel sizes of 214 m, 428 m, and 856 m. It is a scanning instrument with a swath width of 2,300 km. It samples the spectral ranges

of 0.4 to 1.5 μm using 40 bands, 31 of which are considered baseline, the balance being non-baseline.

MODIS-N has a mass of 200 kg, data rate of 8.3 Mbps, and requires 500 watts of power. MODIS-N is baselined for the Eos-A polar platform.

MODIS-T/-N

Team Leader

Vincent Salomonson has over 25 years experience in the fields of meteorology, agricultural engineering, atmospheric science, and hydrology. He was awarded a Ph.D. degree in atmospheric science from Colorado State in 1968, the year he joined Goddard Space Flight Center. He was recently appointed Deputy Director for Earth Sciences within the Space and Earth Sciences Directorate.

Dr. Salomonson brings substantial experience to his role as Team Leader of MODIS. He has functioned on an ad-hoc basis as the MODIS Team Leader for the past three years. He also has over a dozen years experience as the Landsat 4 and 5 Project Scientist including the leadership and management of the Landsat Image Data Quality and Analysis (LIDQA) Investigator Team and Thematic Mapper Research in the Earth

Vincent V. Salomonson

Sciences Investigator Team. Additional experience includes over 14 years as a line manager of research groups at Goddard Space Flight Center and the leadership of the NASA Water Resources Sub-Discipline Panel and Program for several years in the 1970s. He has published research materials directly relevant to the investigation and has over 100 refereed publications, conference proceedings, and NASA reports to his credit.

Dr. Salomonson has been cited on numerous occasions for his outstanding research and scientific achievement. He is the recipient of seven NASA awards for exceptional achievement, service, and performance; of the Distinguished Achievement Award of the IEEE Geoscience and Remote Sensing Society; and of the William T. Pecora Award.

Team Members

Mark R. Abbott, Oregon State University
Ian Barton, CSIRO
Otis B. Brown, University of Miami
Kendall L. Carder, University of South Florida
Dennis K. Clark, NOAA/NESDIS
Wayne Esaias, Goddard Space Flight Center
Robert H. Evans, University of Miami
Howard R. Gordon, University of Miami
Frank E. Hoge, Wallops Flight Center
Alfredo R. Huete, University of Arizona
Christopher O. Justice, University of Maryland
Yoram J. Kaufman, Science Systems and Applications, Inc.

Michael D. King, Goddard Space Flight Center
Paul Menzel, NOAA/NESDIS
Jan-Peter Muller, University College London
John Parslow, CSIRO
Steven W. Running, University of Montana
Philip N. Slater, University of Arizona
Alan H. Strahler, Boston University
Joel Susskind, Goddard Space Flight Center
Didier Tanre, University des Sciences et Techniques de Lille
Vern Vanderbilt, Ames Research Center
Zhengming Wan, Institute of Remote Sensing Application

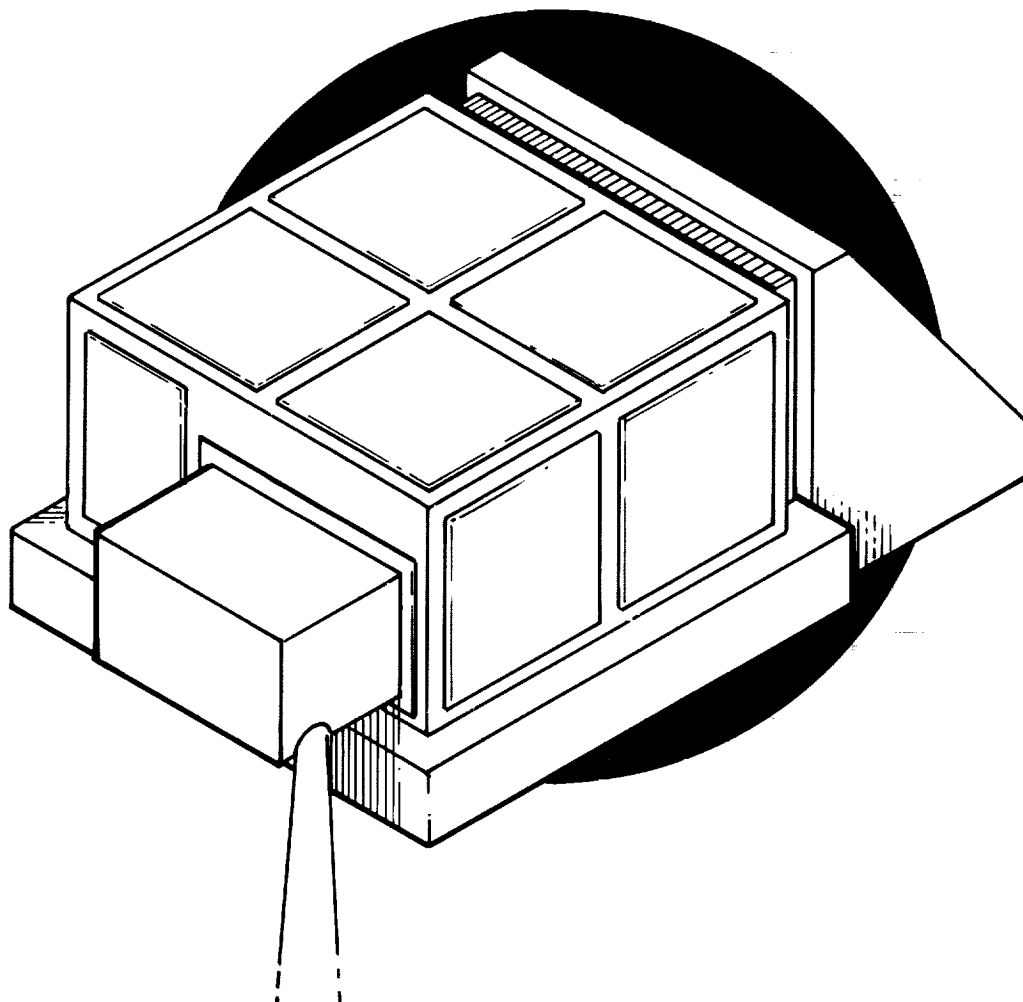

AIRS is an infrared sounder of atmospheric temperature and other properties. AIRS will have an IFOV of 50 km for most of its channels with an IFOV of 15 km for some selected channels and will be capable of scanning cross-track to $\pm 49^\circ$. It will provide continuous atmospheric sounding over this entire swath. AIRS will include measurements with a v/dv of 1,200 in 115

spectral bands in the 3 to 5 μm and 8 to 17 μm spectral regions. The temperature retrievals obtained with AIRS will be accurate to 1 km throughout the vertical extent of the troposphere.

AIRS has a mass of 80 kg, data rate of 1.7 Mbps, and requires 300 watts of power. AIRS is baselined for the Eos-1 platform.

AIRS

Team Leader

Moustafa Chahine was awarded his Ph.D. degree in fluid physics from the University of California at Berkeley in 1960. He is Chief Scientist at the Jet Propulsion Laboratory, where he has been affiliated for nearly 30 years. From 1978 to 1984, he was Manager of the Division of Earth and Space Sciences at JPL; as such he was responsible for establishing the Division and managing the diverse activities of its 400 researchers.

For 20 years, Dr. Chahine has been directly involved in remote sensing theory and experiments. His resume reflects roles as Principal Investigator, designer and developer, and analyst in remote sensing experiments. He developed the Physical Relaxation Method for retrieving atmospheric profiles from radiance observations. Subsequently, he formulated a multispectral approach using infrared and microwave data for remote sensing in the

Moustafa Chahine

presence of clouds. These data analysis techniques were successfully applied in 1980 to produce the first global distribution of the Earth surface temperature using the HIRS/MSU sounders data. Dr. Chahine was integrally involved in the design study of AMTS, the precursor to the current AIRS spectrometer as well. Dr. Chahine served as a member of the NASA Earth System Sciences Committee (ESSC), which developed the program leading to Eos and currently is Chairman of the Science Steering Group of a closely-related effort, the World Meteorological Organization's Global Energy and Water Cycle Experiment (GEWEX).

Dr. Chahine is a Fellow of the American Physical Society and the British Meteorological Society. In 1969, he was awarded the NASA Medal for Exceptional Scientific Achievements and, in 1984, the NASA Outstanding Leadership Medal.

Team Members

Hartmut H. Aumann, Jet Propulsion
Laboratory

Alan Chedin, CNRS/CNES/LMD

Henry E. Fleming, NOAA/NESDIS

Catherine Gautier, Scripps Institution of
Oceanography

John Francis LeMarshall, Bureau of
Meteorology Research Centre

Larry M. McMillin, U.S. Department of
Commerce

Ralph Alvin Petersen, NOAA/NWS/NMC

Henry E. Revercomb, University of
Wisconsin

Rolando Rizzi, Universita di Bologna

Philip Rosenkranz, Massachusetts
Institute of Technology

William L. Smith, University of Wisconsin

David H. Staelin, Massachusetts Institute
of Technology

L. Larrabee Strow, University of Maryland

Joel Susskind, Goddard Space Flight Center

High-Resolution Imaging Spectrometer

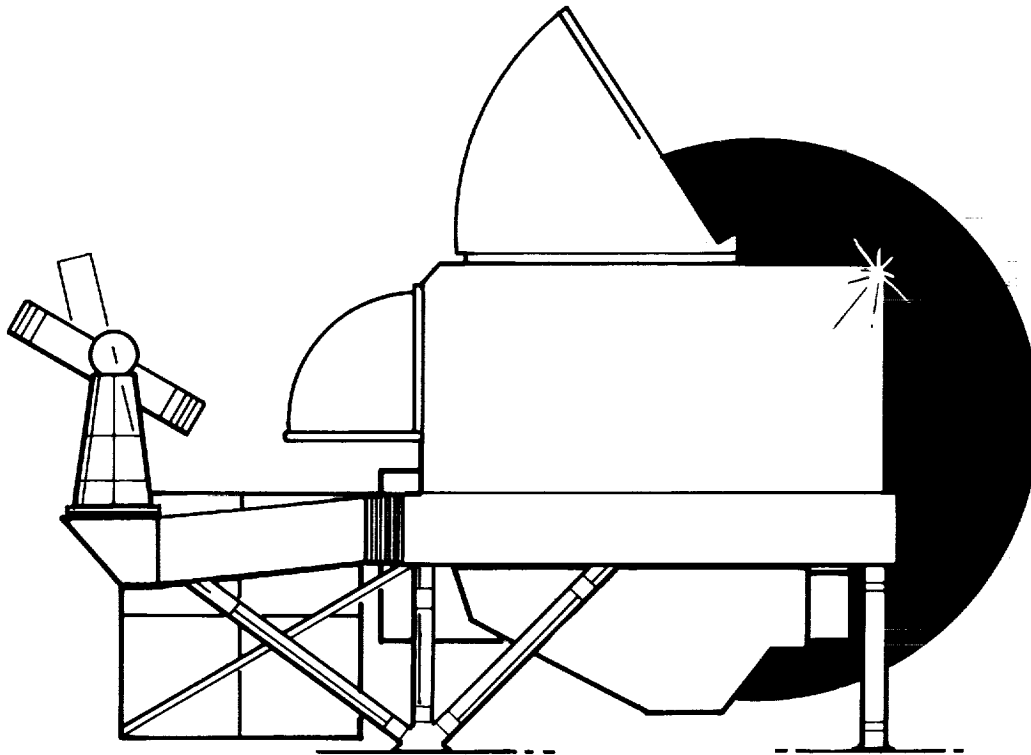

HIRIS is an imaging spectrometer providing highly programmable localized measurements of geological, biological, and physical processes with an IFOV of 30 m over a swath width of 30 km. It is pointable 60° up-track, 30° down-track, and ±24° cross-track. The instrument covers the spectral ranges of 0.4 to 1.0 μm and 1.0 to 2.5 μm , with 9.7 and 11.7 nm resolution, respectively, yielding almost 200 spectral bands. The

instrument has an on-board spectral and radiometric calibrator.

HIRIS has a mass of 987 kg, data rate of up to 280 Mbps, and requires 300 watts of power. Because of its high data rate and fine spatial resolution, HIRIS is planned to be operated 15% of the time. HIRIS is baselined for the Eos-A polar platform.

HIRIS

Team Leader

Alexander Goetz holds degrees in physics, geology, and planetary science from the California Institute of Technology; from 1970 to 1985, Dr. Goetz was affiliated with that institution's Jet Propulsion Laboratory. Presently, he is a Professor in the Department of Geological Sciences and Director of the Center for the Study of Earth from Space/CIRES at the University of Colorado. His current scientific interests include applying remote sensing techniques to a wide range of scientific disciplines, including geology, hydrology, ecology, and atmospheric science. He also develops new instrumentation for field application of remote sensing techniques.

Dr. Goetz has spent over 20 years as a Principal Investigator for flight instruments and data analysis projects in various NASA programs including Apollo, Landsat 1, and Skylab. He served as Imaging Spectrometer Program Manager for JPL for two years and, as such,

Alexander Goetz

developed the concepts for the airborne and spaceborne imaging spectrometers. He was the Principal Investigator for the Shuttle Imaging Spectrometer Experiment, which, although it did not fly, formed the basis for the HIRIS concept. From 1984 to 1987, he chaired the Imaging Spectrometer Science Advisory Group, which developed the requirements for SISEX and HIRIS.

Dr. Goetz's other activities mirror these interests. In addition to being well-published in the current literature, he serves on several advisory boards for the National Research Council; has consulted with private industry here and abroad; has taught an independent short course in advanced remote sensing for geologists and geophysicists; holds four spectral instrument patents; is Associate Editor for two journals; and has received numerous performance and special achievement awards.

Team Members

John Aber, University of New Hampshire
Kendall L. Carder, University of South
Florida

Roger Nelson Clark, U.S. Geological Survey
Curtiss O. Davis, Jet Propulsion
Laboratory

Jeff Dozier, University of California,
Santa Barbara

Siegfried Gerstl, Los Alamos National
Laboratory

Hugh H. Kieffer, U.S. Geological Survey

David A. Landgrebe, Purdue University

John M. Melack, University of California,
Santa Barbara

Lawrence C. Rowan, U.S. Geological Survey

Susan L. Ustin, University of California,
Davis

Ronald Welch, South Dakota School of Mines
& Technology

Carol A. Wessman, University of Colorado

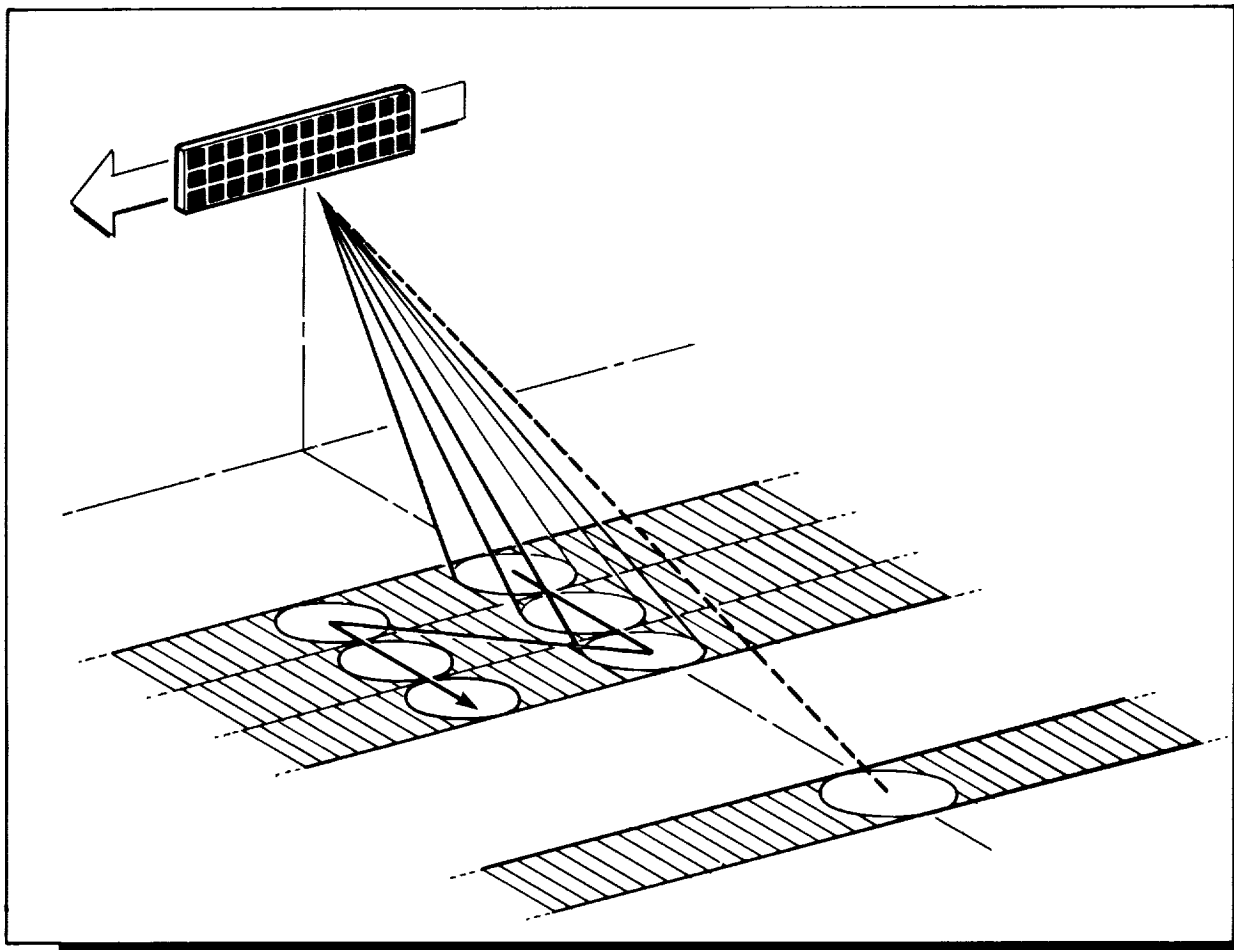

SAR is an imaging radar for all-weather studies of surface processes for land, vegetation, ice, and oceans. The SAR is a three-frequency, L-, C-, and X-band, multipolarization instrument providing HH and VV plus cross-polarization measurements for the C- and L-bands and HH and VV polarization for the X-band. The instrument uses electronic beam steering in the cross-track direction to acquire images at selectable incidence angles from 15 to 55°. The antenna can be rotated to view either side of the ground track. The SAR has a varying spatial resolution and swath-width capability in three distinct modes as follows: 20 to 30 m resolution with a swath width of 30 to 50 km, 50 to 100 m resolution with a swath width of 100

to 200 km, and 200 to 500 m resolution with a swath width of up to 700 km. (The X-band portion of the instrument is to be provided by the Federal Republic of Germany with the collaboration of Italy.)

SAR has a mass of 1,940 kg peak, data rate of up to 280 Mbps, 20 Mbps average data rate, and requires an average of 3,380 watts of power with an 8 kilowatt peak for short periods of time. Because of its high data rate and high power requirements, SAR is planned to be operated 60% of the time. SAR is baselined for the Eos-B polar platform.

SAR

Team Leader

Charles Elachi received his undergraduate degree in physics from the University of Grenoble in France in 1968 and went on to earn graduate degrees in electrical sciences from the California Institute of Technology. He holds a second M.S. degree in geology from the University of Southern California and an M.B.A. from the University of California. He has been affiliated with the Jet Propulsion Laboratory and the California Institute of Technology since 1971 and, in addition to lecturing at CIT, is at present JPL's Assistant Lab Director for Space Science and Instruments.

Dr. Elachi has concentrated his research on the use of spaceborne active microwave instruments and remote sensing of planetary surfaces, atmospheres, and subsurfaces. He has served as Principal Investigator for over a dozen NASA research studies dating back to Apollo 17 on through SIR-A, the first scientific payload carried

Charles Elachi

on the Space Shuttle; he has also been responsible for or participated in a number of mission/sensors development studies. He is the author of nearly 200 publications and two textbooks related to these interests and holds four patents in the fields of interpretation of active microwave remote sensing data, wave propagation and scattering, electromagnetic theory, lasers, and integrated optics.

Among his other professional activities are participation on numerous committees, commissions, working groups, and advisory boards; most relevant in this context was his role as Co-Chairman of the Eos Science SAR Panel from 1985 to 1987. Dr. Elachi was recently invited to join the National Academy of Engineering. Among his numerous awards are the NASA Exceptional Scientific Achievement Medal and the William T. Pecora Award.

Team Members

Frank Carsey, Jet Propulsion Laboratory
JoBea Cimino, Jet Propulsion Laboratory
Edwin Engman, USDA/Agricultural Research Service
Diane Evans, Jet Propulsion Laboratory
Johnny Johannessen, Nansen Remote Sensing Center
Eric Kasischke, Environmental Research Institute of Michigan

William J. Plant, Woods Hole Oceanographic Institution
K. Jon Ranson, Goddard Space Flight Center
Gerald G. Schaber, U.S. Geological Survey
Herman Shugart, University of Virginia
Fawwaz T. Ulaby, University of Michigan
Howard A. Zebker, Jet Propulsion Laboratory

Geoscience Laser Ranging System

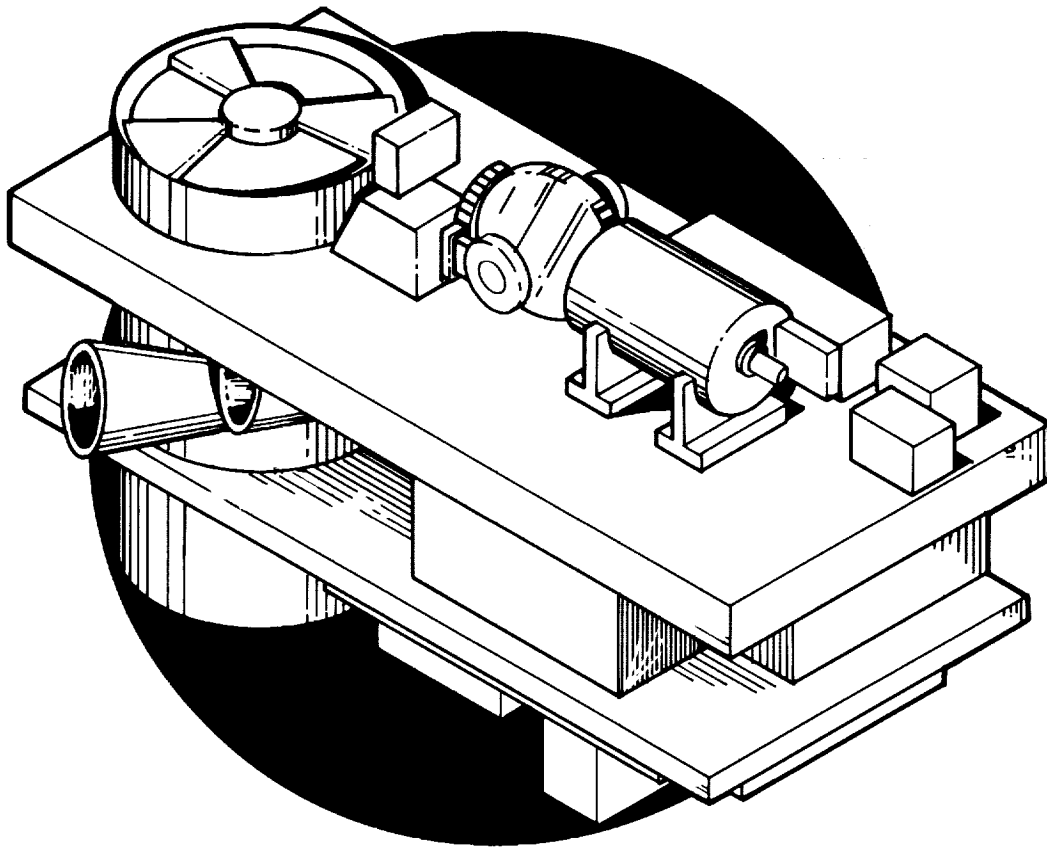

GLRS is a laser ranging system for the study of crustal movements in tectonically active regions and across tectonic boundaries using arrays of retroreflecting targets acquired by the satellite system. In addition, the GLRS has the capacity for high-resolution, decimeter precision, altimetric profiling of ice sheets, land, and cloud top surfaces. The system consists of three major subsystems: a dual-mode laser ranging/altimetry subsystem, a high-speed, high-accuracy optical tracking subsystem, and a navigation and altitude determination subsystem. The system uses a

frequency-doubled and tripled, mode-locked Nd:YAG laser with energy levels of 120 mJ (1,064 nm), 50 mJ (531 nm), and 20 mJ (354 nm), respectively. Pulse repetition rate is variable from 10 to 40 pps. Beam divergence is approximately 0.1 mrad for a spot size of 80 to 290 m.

GLRS has a mass of 445 kg, data rate of 800 kbps, and requires 800 watts of power. GLRS will have a 15% duty cycle. GLRS is baselined for the Eos-A polar platform.

GLRS

Team Leader

Steven Cohen earned academic degrees in physics (Ph.D. University of Maryland, 1973) and has been affiliated with Goddard Space Flight Center for over 20 years; since 1976 he has been with the Geodynamics Branch as a Research Geophysicist. During this time he has conducted basic geophysics research on the scientific issues to be addressed by GLRS including earthquake-related crustal deformations, tectonic plate motions, and plate interactions. In his earlier position with GSFC's Laser Technology Branch, he became familiar with laser operation, requirements, and technical issues and published a variety of journal papers and reports on both lasers and laser detectors. He was formerly a member of the technology group that conducts Goddard's laser development activities and has worked with the engineers involved in GLRS development for a number of years.

Steven Cohen

Dr. Cohen was the sole geodynamics representative to Eos's LASA (Lidar Atmospheric Sounder and Altimeter) Panel; subsequently, he formed a science/engineering committee that completed the conceptual design of GLRS and was appointed GLRS Acting Team Leader when the system was assigned to Goddard for development.

Dr. Cohen has published some 75 technical articles, and co-authored the NASA report on space technology geodesy and its application to crustal dynamics, which became the basis for the current Geodynamics Program and Crustal Dynamics Project. At present he is Editor of an American Geophysical Union monograph on deformation and transmission of stress in the Earth.

Team Members

Charles R. Bentley, University of Wisconsin

Michael G. Bevis, North Carolina State University

Jack L. Bufton, Goddard Space Flight Center

Thomas A. Herring, Harvard University

Kim A. Kastens, Lamont-Doherty Geological Observatory

Jean-Bernard Minster, Scripps Institution of Oceanography

William H. Prescott, U.S. Geological Survey

Robert E. Reilinger, Massachusetts Institute of Technology

Bob E. Schutz, University of Texas, Austin

James D. Spinhirne, Goddard Space Flight Center

Robert H. Thomas, Joint Oceanographic Institution, Inc.

H. Jay Zwally, Goddard Space Flight Center

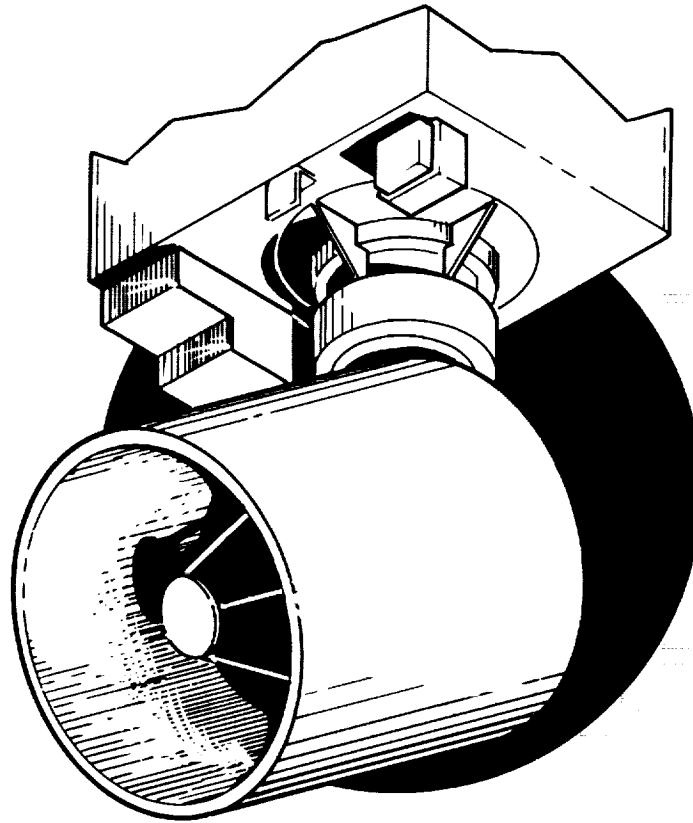

LAWS is a Doppler lidar system for direct tropospheric wind measurements. The instrument consists of a pulsed, frequency-stable CO₂ laser transmitter, a continuously scanning transmit/receive telescope (1.5 m diameter), a heterodyne detector, and a signal processing subsystem. The laser operates at approximately 10 J and 10 Hz pulse repetition rate. The telescope conically scans the subsatellite area and provides coverage

of wind profiles through the troposphere, with a grid spacing on the order of 100 km at a height resolution of 1 km and with an accuracy of 1 to 5 m/s.

LAWS has a mass of 875 kg, data rate of 1.5 Mbps, and requires 2,500 watts of power. LAWS will have a continuous duty cycle. LAWS is baselined for the Japanese polar platform.

LAWS

Team Leader

Wayman Baker is Deputy Chief of the Development Division at the National Meteorological Center of the NOAA. Blending academic skills in mathematics and the atmospheric sciences (Ph.D. University of Missouri, 1978) and professional experience as a meteorologist, he has focused his scientific research on atmospheric dynamics, general circulation, and numerical weather prediction.

Dr. Baker is thoroughly familiar with the LAWS instrument. In 1985 he organized and co-chaired the NASA Symposium and Workshop on Global Wind Measurements, in which more than 100 meteorologists and instrument technologists participated. The recommendations which resulted from the workshop contributed significantly to the selection of the LAWS instrument as one of the NASA Research Facility instruments and helped put the development of

Wayman Baker

the necessary technology on a well-defined path. Since then he has continued his involvement in a wide range of activities relevant to the LAWS instrument. These include: refining the science requirements through participation in the LAWS Working Group, collaborating with scientists participating in related experiments; and exploring various hardware options and data-producing capabilities.

In addition to his work with LAWS, Dr. Baker has contributed often to refereed publications and many technical reports and papers; and frequently serves as a reviewer of proposals for NSF, NASA, and NOAA. Dr. Baker has received several citations and awards including a NASA Special Achievement Award in 1983, the NASA/Goddard Laboratory for Atmospheres Scientific Research Award in 1986, and a NOAA Performance Award in 1989.

Team Members

John R. Anderson, University of Wisconsin
Robert M. Atlas, Goddard Space Flight
Center
George Emmitt, Simpson Weather
Associates, Inc.
R. Michael Hardesty, NOAA
Robert W. Lee, Lassen Research
Andrew Lorenc, Meteorological Office
Robert Menzies, Jet Propulsion Laboratory
Timothy L. Miller, Marshall Space Flight
Center

Madison Post, NOAA/ERL/WPL
Robert A. Brown, University of Washington
John Molinari, State University of New
York
Jan Paegle, University of Utah

Associate Members

David Bowdle, University of Alabama
Dan Fitzjarrald, Marshall Space Flight Center

Japanese Research Facility Instruments (NASDA)

Intermediate Thermal Infrared Radiometer
(ITIR)

ITIR is a radiometer for the global observation of land surface under high resolution for the monitoring of nonrenewable resources. It will have a pointable pushbroom scan system covering the spectral ranges of 0.85 to 0.92, 1.60 to 2.26, and 3.53 to 11.7 μm . The IFOV is 15 m in the near- and short-wavelength IR and 60 m in the thermal IR region.

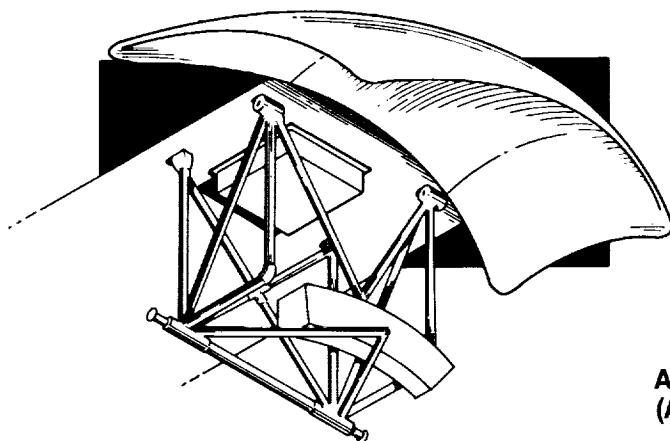
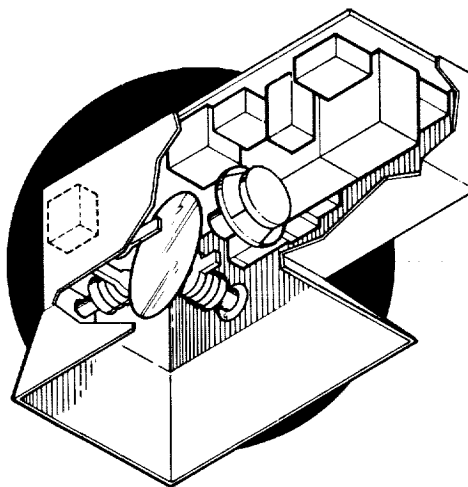

Advanced Microwave Scanning Radiometer
(AMSR)

AMSR is a microwave radiometer for the global observation of atmospheric water vapor, sea surface temperature, and sea surface wind. The AMSR will measure dual-polarized microwave radiation at frequencies of 6.6, 10.65, 18.7, 23.8, and 31.55 GHz. Its spatial resolution varies from 9 to 50 km. Its swath width is 1,200 km. Temperature resolution will be better than 1 K.

United States Endorsements To NASDA

ITIR

Anne B. Kahle
Philip N. Slater
Ronald Welch

AMSR

Robert F. Adler
John C. Alishouse
Donald J. Cavalleri
Josefino C. Comiso
Roy Spencer
Frank J. Wentz
Thomas Wilhelm

**European Space Agency Research
Facility Instruments**

**Medium-Resolution Imaging Spectrometer
(MERIS)**

MERIS is an imaging spectrometer primarily for global ocean color monitoring in 9 bands selectable from a total of 60 bands in the spectral range of 0.4 to 1.04 μm , with a resolution of 10 nm (5 nm goal). The IFOV is 500 m, with an instrument cross-track scan of 1,000 to 1,500 km. The instrument has a $\pm 20^\circ$ tilt capability for sun glint avoidance.

High-Resolution Imaging Spectrometer (HRIS)

HRIS is an imaging spectrometer for land and coastal applications, e.g., geobotanical and vegetation species mapping, geology, agriculture, and forest resources. The spectral range is from 0.4 to 2.5 μm , with a spectral resolution of <20 nm. There are 10 bands, selectable from 100; the swath width is 20 to 60 km; and the IFOV is 20 to 50 m.

Atmospheric Lidar (ATLID)

ATLID is a lidar instrument for atmospheric research and pre-operational meteorology. It measures cloud top height, atmospheric discontinuities, and aerosol layers distribution. It uses a neodymium YAG laser at 0.5 to 1 J level, at 10 Hz repetition rate. The spatial resolution is 10 to 50 km, horizontal; 100 to 500 m, vertical.

Mission-Unique Instruments

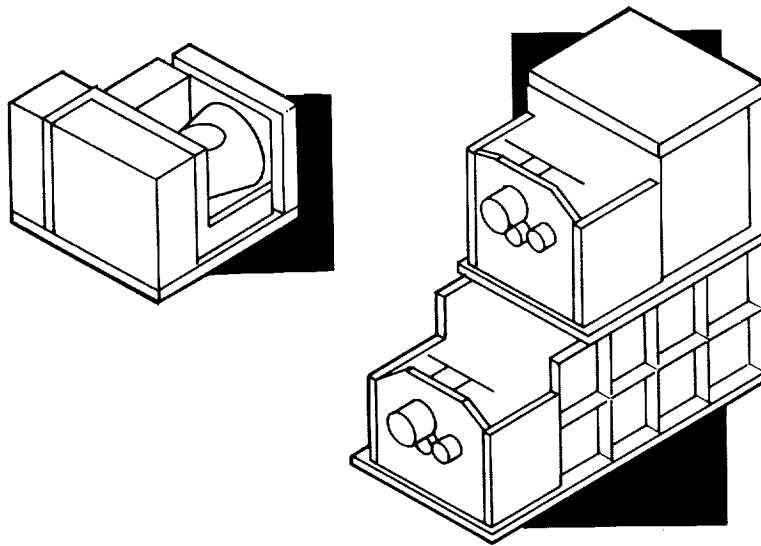

Advanced Microwave Sounding Unit (A and B) (AMSU-A and -B)

AMSU is a microwave radiometer providing measurements of atmospheric temperature and humidity. It is a 20-channel instrument divided into AMSU-A and AMSU-B subsystems. AMSU-A primarily provides atmospheric temperature measurements from the surface up to 40 km in 15 channels, i.e., 23.8 GHz, 31.4 GHz, 12 channels between 50.3 to 57.3 GHz and 89 GHz. Coverage is approximately 50° on both sides of the

suborbital track, with an IFOV of 50 km. Temperature resolution is equivalent to 0.25 to 1.3 K.

AMSU-B primarily provides atmospheric water vapor profile measurements in five channels at 89 GHz, 166 GHz, and 183 GHz (3). Coverage is the same as AMSU-A, with an IFOV of 15 km and a temperature resolution of 1.0 to 1.2 K.

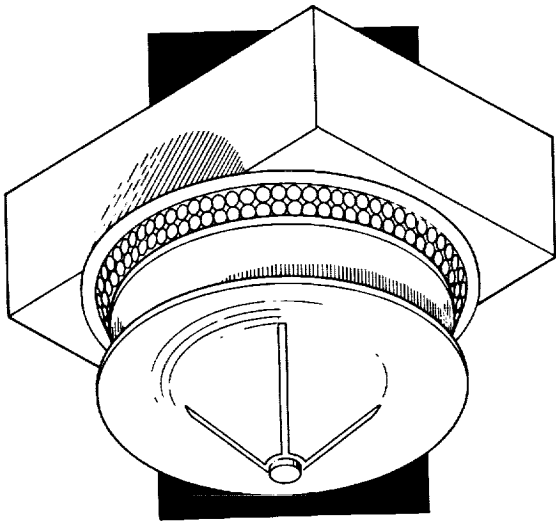

Altimeter (ALT)

The altimeter is a nadir-looking radar measuring the sea surface topography for studies of ocean circulation, tides, marine geophysical processes, and polar ice sheets. Additionally, altimeter return pulse also provides measurements of ocean wind speed and waveheight for studies of sea state and air-sea interactions. The altimeter is a dual frequency radar operating at 13.6 GHz (Ku-band) and 5.3 GHz (C-band). The Ku-band is the primary channel for altitude measurement. The C-band is used for correction for the pulse delay in the ionosphere. The instrument precision for altitude measurement is 2 cm. The footprint of the instrument varies from 2 to 10 km depending on ocean waveheight.

INSTRUMENT INVESTIGATIONS

Barkstrom, Bruce R.
Barnett, John
Beer, Reinhard
Christian, Hugh
Diner, David J.
Drummond, J. R.
Evenson, Paul
Freilich, Michael H.
Gille, John C.
Heelis, R. A.
Kahle, Anne B.
Langel, Robert A.
Mauk, Barry H.
McCleese, Daniel J.
McCormick, M. Patrick
Melbourne, William G.
Parks, George
Reichle, Jr., Henry G.
Rottman, Gary J.
Russell, III, James M.
Spencer, Roy
Travis, Larry D.
Waters, Joe W.
Willson, Richard C.

CERES

Bruce Barkstrom

The instruments of the Clouds and the Earth's Radiant Energy System (CERES) investigation will provide Eos with an accurate and consistent database of radiation. Thus, these instruments will continue the long-term measurement of Earth's radiation budget. In addition, CERES will provide global measurements of atmospheric radiation from the top of the atmosphere to the surface. This work will deepen understanding of the climate system and of atmospheric and oceanic energetics. It will also support extended range numerical weather prediction. The CERES

Clouds And The Earth's Radiant Energy System

Instruments are a pair of broadband, scanning radiometers based on the Earth Radiation Budget Experiment (ERBE) scanners. This design provides them with a space-flight-proven heritage and excellent calibration traceability and stability. CERES will provide radiation data as fluxes at the top of the Earth's atmosphere, at the Earth's surface, and as flux divergences within the atmosphere. CERES also will provide such cloud data as areal coverage, altitude, condensed-water density, and shortwave and longwave optical depths.

BASELINE CERES SCANNER

- Two broadband scanning radiometers: one cross-track mode, one rotating plane -- similar to ERBE
- Each has three channels: total radiance (0.2 to >100 micrometers), shortwave (0.2 to 3.5 micrometers), and longwave (6 to 25 micrometers)
- Thermister bolometer detector: spectral separation through various filter

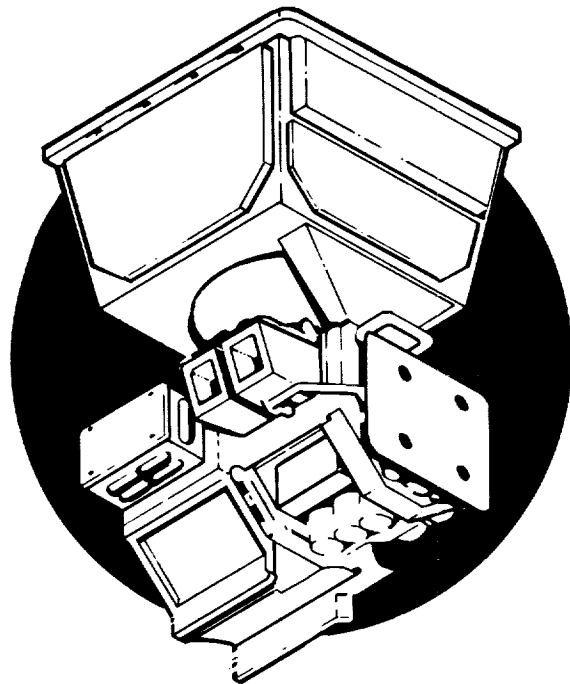

Bruce Barkstrom received a B.S. degree in physics from the University of Illinois. He received his M.S. and Ph.D. degrees in astronomy from Northwestern University. Following a position as Research Associate with the National Center for Atmospheric Research, he had a five-year teaching assignment with George Washington University. In 1979, Dr. Barkstrom joined NASA at

the Langley Research Center. He serves as the ERBE Experiment Scientist and Science Team Leader. As such, he is directly responsible for the ERBE instrument design and calibration, as well as the ERBE data interpretation. He is also responsible for science project management of a team of 17 Principal and 40 Co-Investigators.

DLS

John Barnett

Middle-atmospheric research needs temperature and constituent measurements at a much higher resolution than present or planned sounders will provide, measurements that are essential to obtaining a fundamental understanding of dynamical processes and their interaction with atmospheric chemistry. The Dynamics Limb Sounder (DLS) will measure infrared emission from the stratosphere and mesosphere, and obtain these high-resolution fields of trace chemicals and temperature from which motions and important derived quantities such as potential

Dynamics Limb Sounder

vorticity may be obtained. The instrument, which has a long heritage extending back to the 1970 launch of Nimbus-4, will obtain profiles over the entire globe—including the poles—by day and night, using a steerable view directed along the satellite velocity vector and up to 24° on either side. The observation sequence will be programmable in a flexible manner and the instrument will use cooled 8-element detector arrays, in conjunction with a rapid elevation scan which encompasses the entire middle atmosphere.

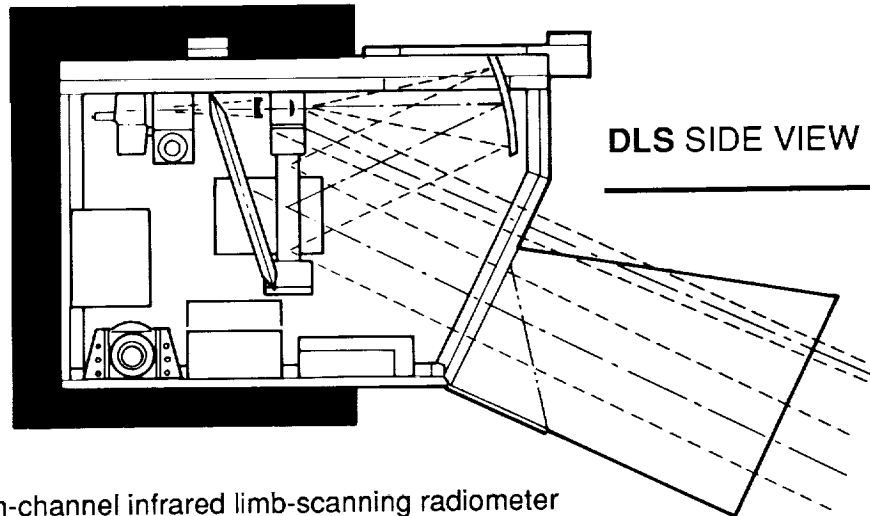

- Fourteen-channel infrared limb-scanning radiometer
- Observes global distribution of upper tropospheric, stratospheric, and mesospheric temperatures and concentrations of O₃, N₂O, CH₄, CFC11, CFC12, and H₂O
- Spectral range is from 7.04 to 17.06 micrometers
- Resolution is 200 to 400 km east-west and north-south; 3.0 km vertical

Dr. Barnett received his B.A. and M.A. in natural sciences, with first class honors, from Cambridge University and his Ph.D. in atmospheric physics from Oxford University. He is currently a Senior Research Officer for the Department of Atmospheric, Oceanic, and Planetary Physics at Oxford. Dr. Barnett served as a member of data processing teams for the suite of Nimbus

instruments, as Co-Investigator for Improved Stratospheric and Mesospheric Sounder (ISAMS), and as co-chairman of the COSPAR task group on the Reference Middle Atmosphere. He is the recipient of the COSPAR William Nordberg Award and the Royal Meteorological Society L. F. Richardson Award.

TES

Reinhard Beer

TES is a passive, high-spectral-resolution, cryogenic, infrared, imaging Fourier transform spectrometer with sufficient spectral coverage to permit the near-simultaneous measurement of most infrared-active minor constituents of the troposphere and lower stratosphere. It is capable of determining the horizontal and vertical distribution of a wide variety of naturally-occurring and man-made chemical species on a global basis. The instrument has two operating modes:

Tropospheric Emission Spectrometer

nadir mode offering good horizontal spatial resolution and a limb-viewing mode offering enhanced sensitivity for trace constituents with good vertical resolution but limited horizontal resolution. Combined results from these two modes permit three-dimensional concentration maps of crucial tropospheric species to be generated and, in turn, become inputs to physical and chemical models of the lower atmosphere from which the state of the troposphere can be assessed.

TROPOSPHERIC EMISSION SPECTROMETER (TES)

- Downlooking and limb-viewing cryogenic-imaging Fourier transform spectrometer
- Infrared emission measurements of tropospheric molecules
- Detector assemblies cooled to 65 K by four stirling-cycle coolers; interferometer and foreoptics cooled to 150 K by two additional stirling-cycle coolers

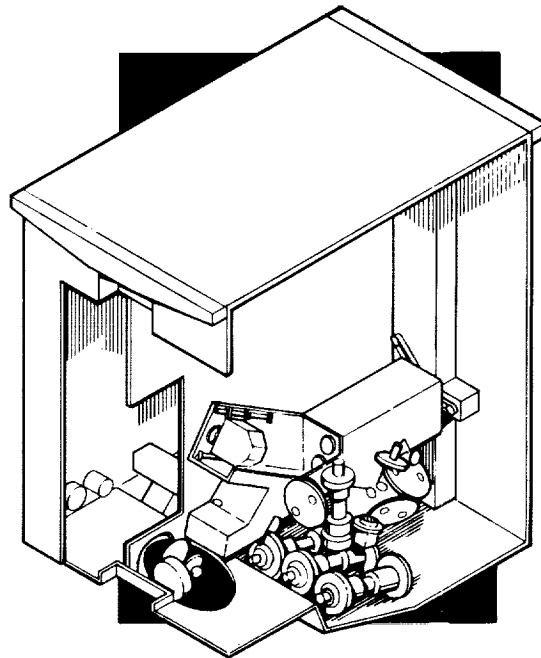

Dr. Beer received his B.Sc. and Ph.D. degrees in physics from the University of Manchester, United Kingdom. He has been associated with the Jet Propulsion Laboratory since 1963; his current position is that of Senior Research Scientist and Supervisor of the Atmospheric Radiation Group, Atmospheric and Oceanographic Sciences Section. Dr. Beer was chairman of the NASA

Infrared Experiments Working Group and now serves as Co-Investigator on the Spacelab ATMOS experiment and the proposed Cassini Probe Infrared Laser Spectrometer. He has been awarded the NASA Exceptional Scientific Achievement Medal and numerous NASA group achievement awards and certificates of recognition.

LIS

Hugh Christian

The calibrated optical Lightning Imaging Sensor (LIS), will acquire and investigate the distribution and variability of lightning over the Earth. LIS is conceptually a simple device, consisting of a staring imager optimized to detect and locate both intracloud and cloud-to-ground lightning with storm-scale resolution over a large region of the Earth's surface, mark the time of occurrence, and measure the radiant energy. It will monitor

Lightning Imaging Sensor

individual storms within the field-of-view long enough to estimate the lightning flashing rate. The investigations will contribute to several important Eos mission objectives. Lightning activity is closely coupled to storm convection, dynamics, and microphysics, and can be correlated to the global rates, amounts, and distribution of precipitation and to the release and transport of latent heat.

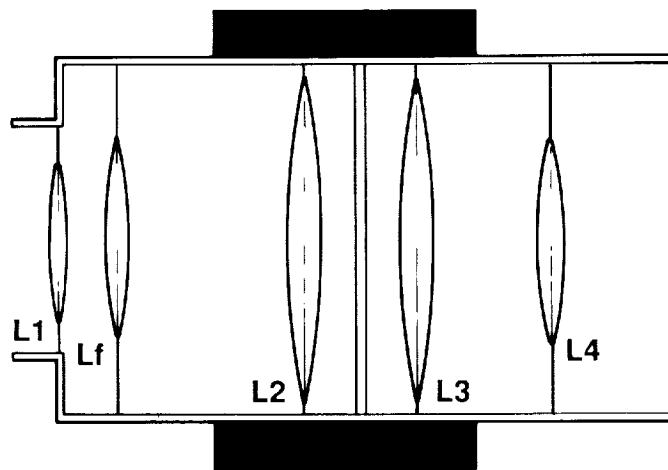

LIS - LIGHTNING IMAGING SENSOR

- Staring telescope/filter imaging system
- 90% detection efficiency under both day and night conditions using background remover and event processor
- Storm-scale (10 km) spatial resolution; 1 ms temporal resolution

Hugh Christian is a graduate of the University of Alaska and received his M.S. and Ph.D. degrees in space physics and astronomy from Rice University. He has served in various government, private industry, and academic capacities, primarily within his area of expertise: thunderstorms, atmospheric electricity, lightning

data acquisition systems, and airborne instrumentation. Since 1980 Dr. Christian has been a Space Scientist at the Marshall Space Flight Center; in conjunction with his research he has published numerous articles, has served as presenter at related conferences, and served on many scientific committees.

MISR

David J. Diner

The MISR experiment addresses the effects of geophysical processes and human activities on the Earth's ecology and climate. Scientific objectives include study of the climatic and environmental impacts of atmospheric aerosols; characterization of heterogeneous cloud fields and their impact on the shortwave radiation budget; and investigation of biosphere-atmosphere interactions and ecosystem change. Measurement objectives include top-of-

Multi-angle Imaging Spectro-Radiometer

atmosphere, cloud and surface angular reflectances and hemispherical albedos; aerosol opacity, absorptivity, and loading; vegetation canopy distribution and architecture; and estimates of phytoplankton pigment concentration in the tropical oceans. MISR will also provide data necessary to validate marine aerosol retrievals from MODIS and to correct HIRIS and MODIS Images for atmospheric effects.

THE MISR INSTRUMENT

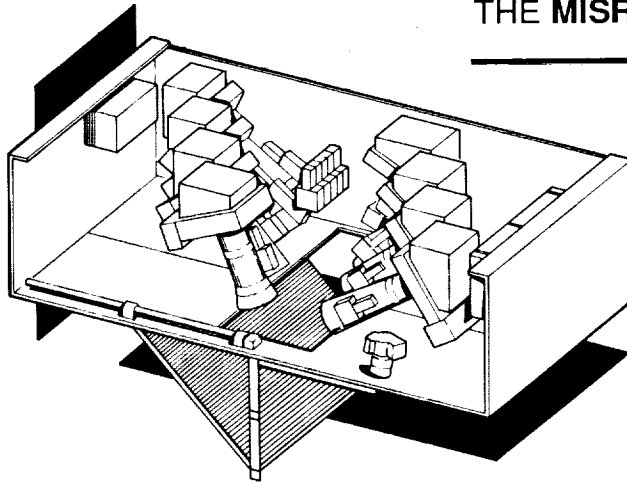

- Eight identical CCD-based pushbroom cameras at four viewing angles 28.5°, 45.6°, 60°, and 72.5°, fore and aft
- Continuous simultaneous imaging in four narrow spectral bands from 440 nm to 860 nm
- Spatial resolution of 1.73 km and 216 m (local mode) are available
- Global coverage every 16 days

David J. Diner received his B.S. degree in physics with honors from the State University of New York at Stony Brook and his M.S. and Ph.D. degrees in planetary science from the California Institute of Technology. He joined the Jet Propulsion Laboratory as a National Research Council Resident Research Associate in 1978 and is currently a Technical Group Supervisor in the

Atmospheric and Cometary Sciences Section. He has been involved in numerous NASA planetary and Earth remote-sensing investigations, as Principal- and Co-Investigator. He presently provides science support to the HIRIS project and is a member of the NASA Land Aircraft Science Management Operations Working Group.

MOPITT

James Drummond

Measurements Of Pollution In The Troposphere

Measurements of Pollution in the Troposphere (MOPITT) will measure carbon monoxide (CO) concentrations in the troposphere with the primary objective of enhancing knowledge of the lower atmosphere system and particularly how it interacts with the surface, ocean, and biomass systems. The investigation uses a radiometer instrument which operates by sensing upwelling

infrared radiation in several bands of CO. As well as measuring the total amount of CO, profiles with a resolution of 25 km horizontally, 3 km vertically and with an accuracy of 10% will be obtained throughout the troposphere. 3-D global maps will be constructed and used in a parallel modeling effort to advance understanding of global tropospheric chemistry.

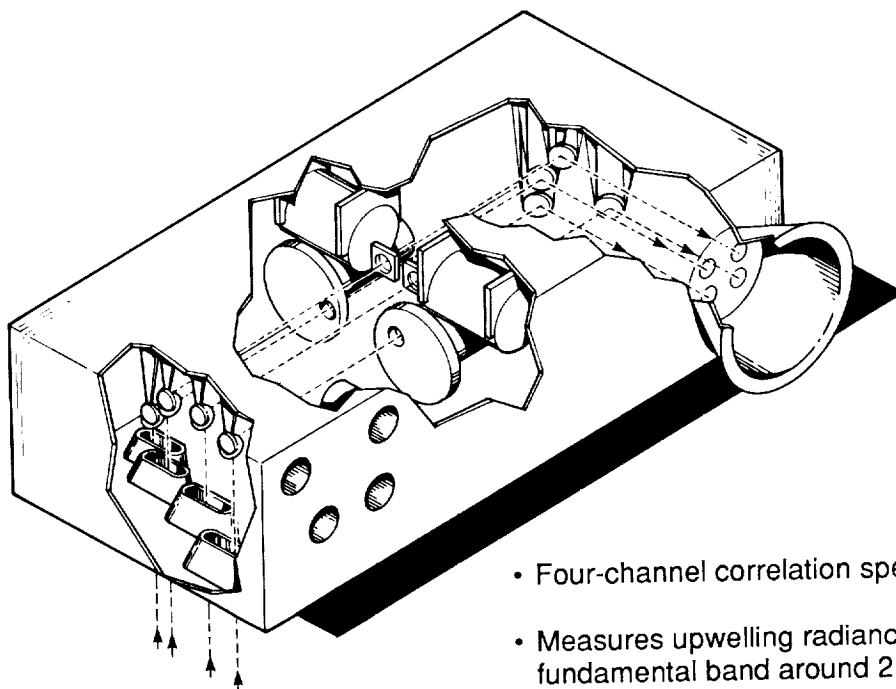

MOPITT INSTRUMENT CONCEPT

- Four-channel correlation spectrometer
- Measures upwelling radiance in the CO fundamental band around $2,140\text{ cm}^{-1}$
- Uses pressure modulation and length modulation cells to obtain CO concentrations in 3 km layer
- Cross-track scanning

James Drummond has taught in the Physics Department of the University of Toronto since 1979, as Associate Professor since 1984. He studied at Oxford University where he obtained his B.A. and D.Phil. degrees in physics. He was a Visiting Scientist in the Atmospheric Chemistry Division of NCAR in 1987. His research interests

are in the field of atmospheric measurements and modeling and he has participated in several balloon and spacecraft experiments. Dr. Drummond has presented research papers at international meetings and symposia, and in refereed journals.

Paul A. Evenson

POsitron Electron Magnet Spectrometer

POEMS (POsitron Electron Magnet Spectrometer) is an investigation designed to take advantage of the unique opportunity presented by the Eos polar platform(s) to fill a basic need in the area of particle astrophysics and at the same time study the nature and the temporal variation of the charged particle radiation in near Earth space. POEMS will measure the critical positron (e^+) and electron (e^-) components of the cosmic radiation and utilize this information to trace processes

occurring in solar flares, in the heliosphere, within our geospace environment, and elsewhere in the galaxy. POEMS data will allow investigation of the primary or secondary origin of galactic positrons; the study of the charge sign dependence of solar modulation over a large fraction of a solar cycle; measurement of the e^+ fraction, and the neutral emission from solar flares; and the monitoring of the temporal variations of the charged particle intensities and energy spectra in the Eos orbit.

POEMS MOUNTED ON ZENITH SURFACE OF EOS POLAR PLATFORM

- Magnet spectrometer with 6 cm^2 Sr collection power
- Flux-return permanent magnet; solid-stripe, solid-state detector
- Measures positrons and electrons in 5 MeV to 5 GeV range; proton and helium fluxes in 30 MeV to 20 GeV range
- Provides spectra of protons, helium, and heavier nuclei in 30 MeV to 10 MeV range

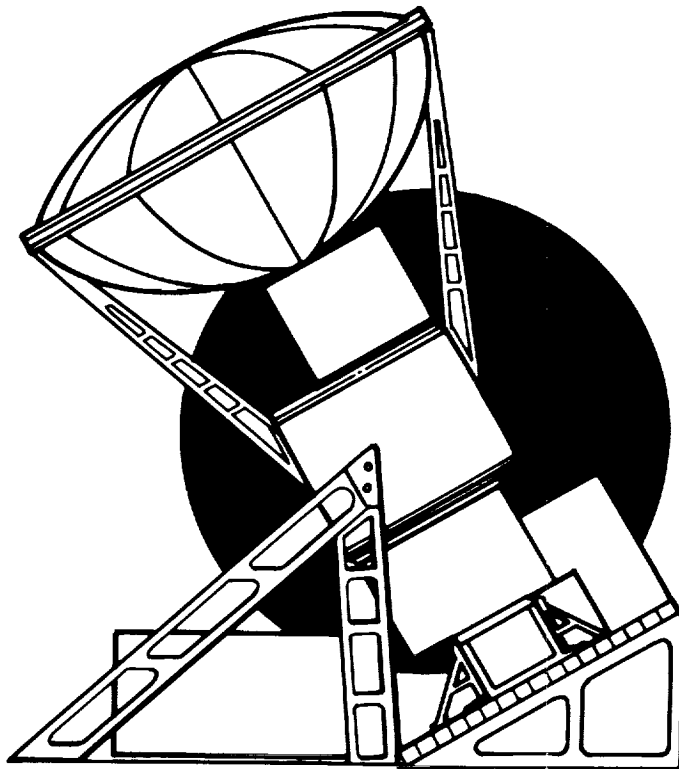

Paul Evenson received his B.A., M.A., and Ph.D. degrees in physics from the University of Chicago, where he also served as Research Associate and Senior Research Associate in the Enrico Fermi Institute. He has been honored as a National Science Foundation Graduate Fellow, a NATO

Fellow at the Danish Space Research Institute, Guest Scientist at the Max-Planck Institute for Extraterrestrial Studies, and as recipient of the NASA Group Achievement award. Currently, Dr. Evenson is Associate Professor at the University of Delaware Bartol Research Institute.

SCANSCAT

Michael H. Freilich

SCANSCAT is an advanced, scanning pencil-beam scatterometer capable of acquiring accurate, high-resolution (25 km), all-weather measurements of surface wind speed and direction over the tropical oceans. Because tropical surface wind speeds are low and variable on time scales as short as one day, accurate and frequent measurements of tropical wind velocity

Advanced Scatterometer For Studies In Meteorology And Oceanography

are necessary, yet difficult to obtain using conventional or planned remote-sensing techniques. SCANSCAT, based on Seasat and NSCAT heritage, provides design enhancements that will result in high accuracy at low wind speeds. Data products from SCANSCAT include surface wind, wind stress, and wind divergence.

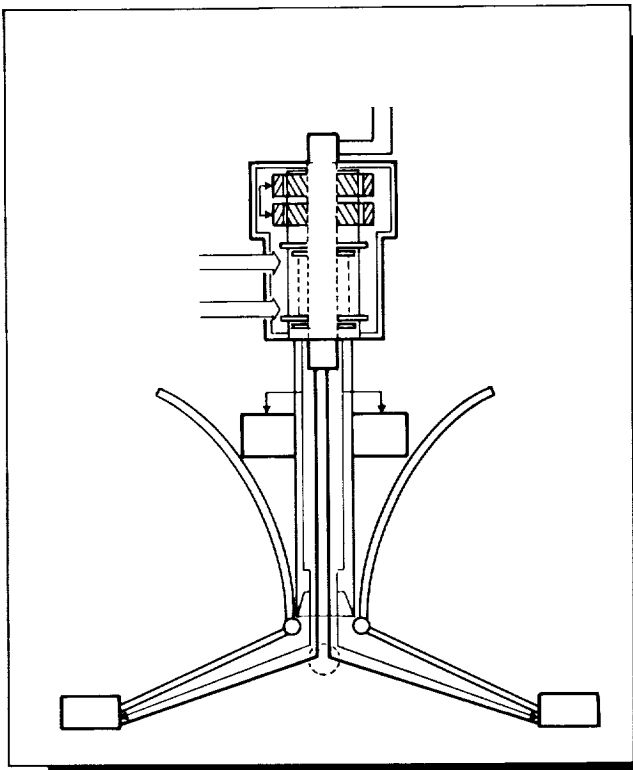

SCANSCAT ANTENNA SUBSYSTEM

- Dual-scanning pencil-beam scatterometer at 13.995 GHz
- Measures ocean-surface wind speed and direction
- Wind speed accuracies of 20% at less than 3 m/s and 10% for 3 to 30 m/s
- Directional accuracy 20%
- 25 km spatial resolution and coverage over a 1,100 km swath
- Two 1.9 m offset-feed parabolic antennas

Michael Freilich received degrees in Physics (Honors) and Chemistry from Haverford College and a Ph.D. in Oceanography from Scripps Institution of Oceanography. From 1982-83 he was Assistant Professor of Oceanography at the Marine Sciences Research Center, SUNY. He joined Jet Propulsion Laboratory in 1983 as a member of the Oceanography Group studying

scatterometry and surface wave dynamics. He is a Principal Investigator and Coordinating Investigator on the ESA ERS-1 Science Working Team and, since 1983, has been Project Scientist for the NASA Scatterometer (NSCAT) Project. He chairs the NSCAT Science Definition Team and is responsible for all science-related aspects of the NSCAT Project.

HIRRLS

John Gille

HIRRLS is an infrared limb scanning radiometer designed to sound the upper troposphere, stratosphere, and mesosphere to determine the temperature and concentrations of O₃, H₂O, CH₄, N₂O, NO₂, HNO₃, and aerosols. The goals are to make observations with horizontal and vertical resolution superior to that obtained before, to observe the lower stratosphere with improved sensitivity and accuracy, and to use these data to improve understanding of atmospheric processes through data analysis, diagnostics and use with 2- and 3-dimensional models. High horizontal

High Resolution Research Limb Sounder

resolution is obtained by a commandable azimuth scan mirror. High vertical resolution is obtained by 1 km fields-of-view, improved optics and electronic filtering, and an option for slower scan rates. Observations of the lower stratosphere are improved by the choice of more-transparent spectral channels. The instrument is commandable, thus a large number of pre-planned observing strategies can be used, and it can be adapted in flight to observe unexpected geophysical events.

CUTAWAY VIEW OF THE HIRRLS INSTRUMENT

- Twelve-channel infrared limb-scanning radiometer
- Observes global distribution of upper tropospheric, stratospheric, mesospheric temperatures and concentrations of O₃, H₂O, CH₄, N₂O, NO₂, HNO₃, and aerosols
- Spectral region from 6.08 to 17.99 micrometers
- Resolution 5° longitude x 5° latitude x 2.5 km vertical

John Gille received his B.S. in physics, magna cum laude, from Yale University; his M.A. in physics from Cambridge University; and the Ph.D. in geophysics from MIT. Since 1977 he has served as Head of the Global Observations, Modeling, and Optical Techniques Section of NCAR. Dr. Gille was Co-Sensor Scientist on LIMS, launched on Nimbus-7 in 1978; and was Principal Investigator on LRIR, which flew on Nimbus-6 in 1975. He has been involved in

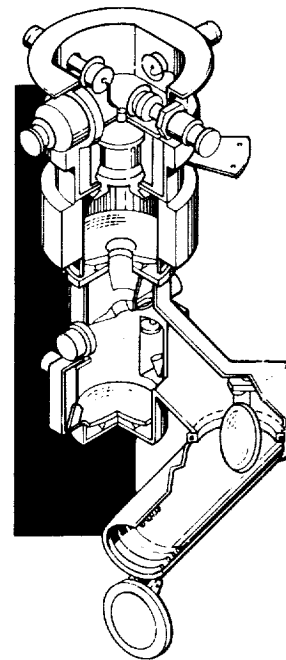

CLAES collaboration since 1982, with NOAA's development of GOMR, and on several investigations analyzing satellite data. He is a Fellow of the American Meteorological Society and the American Association for the Advancement of Science, and was the recipient of the NCAR Technology Advancement Award in 1978 and the NASA Exceptional Scientific Achievement Medal in 1982.

Roderick Heelis

The Ionospheric Plasma and Electrodynamic Instrument (IPEI) will measure the thermal ion temperature, composition, and dynamics in the ionosphere. These measurements serve as remote sensors of the electric fields generated in the lower atmosphere by motions of the charged and neutral particles and electric fields generated by the interaction of the Earth with the interplanetary environment. The measurements will also monitor the energy transport and conversion processes that take place as a result of interactions with the lower atmosphere and the

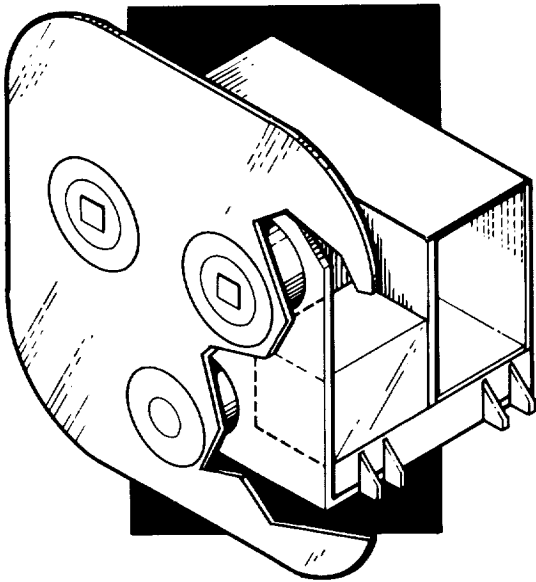

Academically trained in applied mathematics, Roderick Heelis has concentrated his professional career in planetary ionospheres, and magnetospheres; and the physical phenomena coupling these regions. He has been affiliated with the University of Texas at Dallas, Center for Space Sciences for the last 16 years; since 1986 he has served as Associate Director. He is a member of the Dynamics Explorer Flight Team

Ionospheric Plasma And Electrodynamic Instrument

upper atmosphere. When used in conjunction with energetic particle and magnetometer data, the energy input to the lower atmosphere can be expressed as a Poynting flux. Questions pertaining to thermal ion supply to the magnetosphere, the characteristics of the high-latitude electric field and associated frictional heating, the roles of neutral atmosphere motions near 120 km altitude, and the effects of propagating gravity waves will also be addressed with data from IPEI.

IPEI INSTRUMENT

- Retarding mass analyzer (RPMA) and ion drift meter (IDM)
- Determines thermal energy distribution and thermal ion arrival angle with respect to spacecraft velocity
- Also determines relative abundance of ionospheric constituents H⁺, He⁺, O⁺
- Ion drift is measured in the range of 10 to 5,000 m/s in 3 directions; concentrations are measured in the range of $1-5 \times 10^6 \text{ cm}^{-3}$

and has served as member or Chair of numerous committees concerned with space physics. He is well-published in the field and, in addition, is a past Associate Editor of the Journal of Geophysical Research and the recipient of that Journal's Citation for Excellence in Refereeing. Dr. Heelis is also listed in American Men and Women of Science.

TIGER

Anne B. Kahle

Thermal Infrared Ground Emission Radiometer

TIGER will make quantitative spectral measurements of the emitted radiation from the Earth's surface at spatial and spectral resolutions appropriate for geological, climatic, hydrological, and agricultural studies. The instrument utilizes a Thermal Infrared Mapping Spectrometer (TIMS), which will have a total of 14 channels. Earth's thermal infrared spectral region contains a wealth of surface compositional information for a wide range of geologically important materials that are difficult or impossible to distinguish using visible or near-IR observations. Thus TIGER data,

coupled with highly complementary solar-reflectance data acquired by HIRIS, provides the opportunity to measure and map the composition of continental rock units on a regional and global basis. The science team will undertake comparative global studies related to paleoclimate and proposes to develop techniques for surface temperature retrieval and to apply these data to agricultural and climatological problems. The TIGER team also will build a database of digital spectral radiance images of a large fraction of the land surface of the Earth.

TIGER FOCAL PLANE ARRAYS

- Thermal infrared imaging spectrometer for surface compositional mapping for geology and volcanology
- Provides spectral image measurements of global irradiances in the 3 to 5 micrometer and 8 to 13 micrometer atmospheric windows
- IFOV of 90 m and a swath of 30.2 km

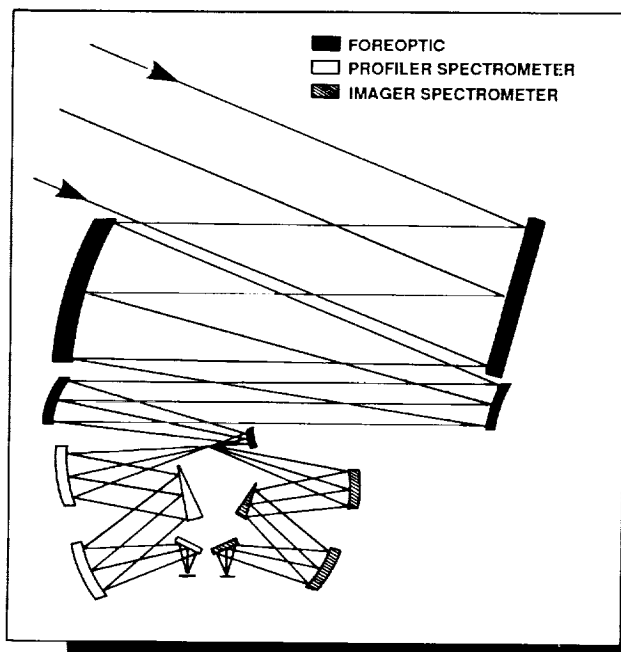

Anne Kahle received a B.S. degree in physics and the M.S. in geophysics from the University of Alaska, and her Ph.D. in meteorology from UCLA. Following a 13-year tenure as Physical Scientist with the Rand Corporation, she joined the Jet Propulsion Laboratory in 1974 and is currently Manager of the Land Processes Program and

Supervisor for the Geologic Remote Sensing Group. Dr. Kahle is integrally involved in state-of-the-art remote sensing, with emphasis on geologic applications; as such she has directed or participated in many related investigations and study groups.

Robert Langel, III

The magnetic field of the Earth will be measured by a three-axis fluxgate and a scalar helium magnetometer. Measurement accuracy goals are 2.0 nT root sum square (rss) for the scalar magnitude and 5.0 nT, rss, for each component. The magnetometers, together with non-magnetic star trackers, will be mounted on an optical platform at the end of a boom. The data will be used both to study the Earth's interior and the electrodynamic ionosphere-magnetosphere coupling. The team proposes specifically to:

Geomagnetic Observing System

1) accurately model the magnetic field and its temporal change; 2) study core fluid dynamics; 3) study correlation with length-of-day changes; 4) study mantle conductivity; 5) measure characteristics and generation mechanisms of field-aligned and ionospheric currents; 6) investigate dynamics and energetics of the high-latitude ionosphere; and 7) together with other spacecraft, do a multi-point investigation of the large-scale structure and dynamics of the auroral regions.

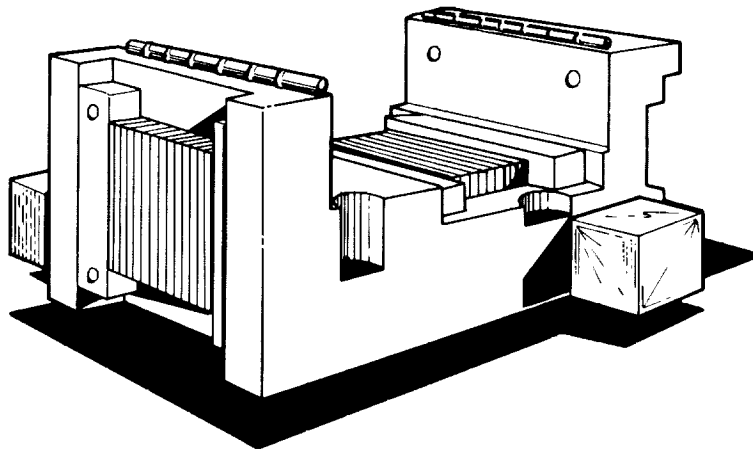

GOS VECTOR MAGNETOMETER SENSOR

- Boom-mounted vector fluxgate magnetometer; scalar-helium magnetometer
- Obtains absolute scalar fields at ± 1 nanoteslas accuracy; vector fields at ± 3 nanoteslas per axis, rss
- Two orthogonal scalar magnetometers/tri-axial vector magnetometer mounted at end of 50 m boom
- Three star trackers provide pointing knowledge

Dr. Langel has studied the Earth's magnetic field since the mid-1960s. He has pioneered in the development of modeling methods and has written a definitive work on main-field modeling. His Ph.D. degree is in physics and he has been associated with Goddard Space Flight Center since 1963, from 1975 with the Geophysics Branch, Laboratory for Terrestrial Physics. He

was part of the magnetometer team for the POGO spacecraft, was project scientist for Magsat, and is NASA study scientist for MFE/Magnolia. He was recipient of the NASA Exceptional Scientific Achievement Medal, was Visiting Scholar at Cambridge University in 1983-84, and is a recently elected fellow of the American Geophysical Union.

ENACEOS

Barry H. Mauk

Energetic Neutral Atom Camera for Eos

The Energetic Neutral Atom Camera for Eos (ENACEOS) will obtain global "all sky" images of incoming Energetic Neutral Atoms (ENA) and thereby remotely sense the global structure and dynamics of the Earth's magnetosphere by means of its energetic ion populations (≥ 20 keV). Its complementary ion detectors will locally measure in situ precipitating and trapped ion populations providing detailed composition, spectral, and

angular signatures over ranges corresponding to those of the remotely sensed ENA fluxes. ENACEOS will provide for the first time global monitoring of the magnetosphere system, a critical input for quantifying magnetosphere/ionosphere/atmosphere coupling. The investigators are: B.H. Mauk, E.P. Keath, R.W. McEntire, D.G. Mitchell, E.C. Roelof, and B.F. Tinsley.

ENACEOS INSTRUMENT

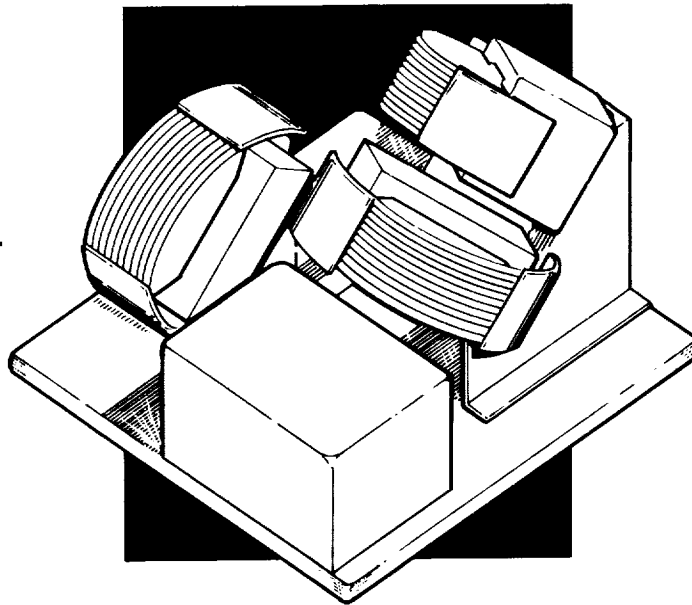

- Three sensor heads; charge rejection plates discriminate between ions and energetic neutral atoms (ENA)
- Ions and ENAs sorted as to energy (20 keV to several MeV) and mass species, e.g., H, He, O
- Obtains spatial images of ENA sources

Barry Mauk received his B.A., M.S., and Ph.D. degrees in physics from the University of California, San Diego. Following a research position at the University of Washington, where he was Co-Investigator on an x-ray imaging balloon program, Dr. Mauk joined the Applied Physics Laboratory of the Johns Hopkins University in 1982 as Senior Staff Physicist. His most recent activities include experimental and theoretical

investigations of magnetospheric substorm injection and convection dynamics and of the interactions between electromagnetic cyclotron waves and heavy ions; the development of space instrumentation; and an additional role as Co-Investigator for operations and scientific investigations with the Voyager spacecraft, for which he was awarded a 1986 NASA Group Achievement Award.

SWIRLS

Daniel J. McCleese

The SWIRLS investigation will describe stratospheric structure, dynamics, and transport processes, and study their influences on natural and anthropogenically forced stratospheric change. Direct measurements of wind are necessary to understand the physical mechanisms that determine the structure and dynamics of the stratosphere, and the transport of chemically active species, including ozone. Satellite temperature measurements have proved to be

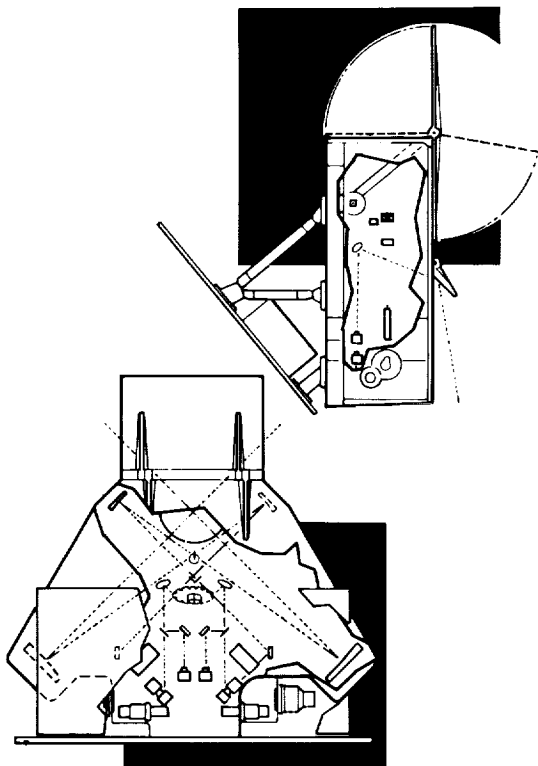

Daniel McCleese was a Fulbright Scholar at Oxford University and earned his D.Phil. degree in atmospheric physics from that institution in 1976. He joined Jet Propulsion Laboratory that same year and is presently the Manager of the Earth and Space Sciences Division. Dr. McCleese has been or is currently Principal Investigator on several SWIRLS-related investigations including

Stratospheric Wind Infrared Limb Sounder

inadequate for this purpose. SWIRLS offers direct measurements on both the day and night sides of the Earth by observing the Doppler shift in stratospheric emission using a powerful new gas-correlation technique that employs electro-optic phase modulation (EOPM). EOPM gas-correlation radiometry provides the high spectral discrimination required to measure winds with necessary spatial resolution and accuracy.

SWIRLS MECHANICAL CONFIGURATION

- Gas correlation and filter infrared radiometer
- Observes atmospheric infrared emissions in the 7.6 μm to 17.2 μm range
- Obtains continuous vertical profiles of horizontal wind vectors, temperatures, and pressures; and mixing ratios of ozone and nitrous oxide
- Wind velocities are determined from wind-induced Doppler shifts in the N_2O emission spectrum
- 3 km vertical resolution in a 20 km to 60 km altitude range on both the day and night sides of the Earth

Mars Observer, Pressure Modulator Infrared Radiometer, Cassini Stratospheric Sounder, and the Infrared Experiment Definition Program. He is well published in the literature and has been honored as a Fellow in the Royal Meteorological Society and with NASA recognition and group achievement awards.

SAGE III

M. Patrick McCormick

The Stratospheric Aerosol and GAS Experiment III (SAGE III) will measure profiles of aerosols, ozone, nitrogen dioxide, water vapor, and air density between cloud tops and the upper mesosphere. The instrument is a natural and improved extension of the successful SAM II, SAGE I, and SAGE II experiments which will include additional wavelengths to accomplish the following: (1) improve the aerosol

Stratospheric Aerosol And Gas Experiment III

characterization; (2) improve the gaseous retrievals of O_3 , H_2O , NO_2 ; (3) extend the vertical range of measurement; and (4) provide independence from any external data needed for retrieval. SAGE III will provide aerosol and cloud data essential for the calibration and interpretation of data from other remote sensors on the Eos platforms.

SAGE III SENSOR ASSEMBLY

- Earth-limb scanning grating spectrometer
- Obtains global profiles of aerosols, O_3 , H_2O , NO_2 , clouds, and air density in the mesosphere, stratosphere, and troposphere
- 1 to 2 km vertical resolution

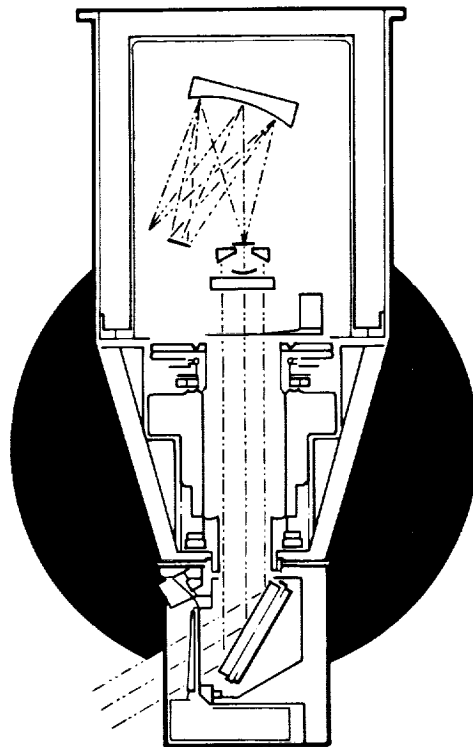

M. Patrick McCormick received his M.A. and Ph.D. degrees in physics from the College of William & Mary. He has been with NASA/Langley Research Center since 1967 and is presently Head of the Aerosol Research Branch. Dr. McCormick is Principal Investigator on SAM II, SAGE I, and SAGE II spaceflight experiments as well as numerous other atmospheric remote sensing instruments and data analysis experiments. He received the Arthur S. Flemming Award for Outstanding Young People in Federal Service in

1979, the NASA Exceptional Scientific Achievement Medal in 1981 and numerous NASA Group or Special Achievement Awards. He received an Honorary Doctor of Science degree from the Washington & Jefferson College in 1981 where he presently serves on the Board of Trustees. Dr. McCormick is a member of the International Radiation Commission and Chairs the International Coordination Group on Laser Atmospheric Studies.

GGI

William G. Melbourne

GGI is a high-performance Global Positioning System (GPS) receiver-processor. It will include 18 dual-frequency satellite channels and three distributed GPS antennas. The antennas will be distributed and oriented to provide full sky coverage down to the limb of the earth and information for three-dimensional attitude determination. GGI will serve four principal science objectives: centimeter-level global

GPS Geoscience Instrument

geodesy; high-precision atmospheric temperature profiling; ionospheric gravity wave detection and tomographic mapping; and precise position and attitude determination in support of other science instruments. The flight instrument is derived from the GPS flight receiver developed for Topex-Poseidon, the US/French oceanographic mission to be launched in 1991.

STRAWMAN GGI CONFIGURATION FOR POLAR PLATFORM

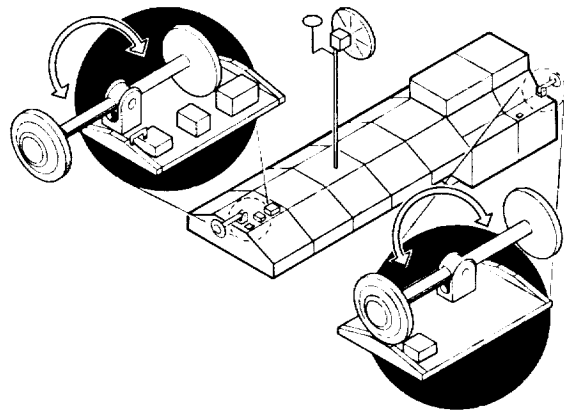

- GPS flight receiver-processor; may include up to 18 dual-frequency satellite channels
- Three hemispherical pattern antennas on the polar platform and network of 10 GPS ground receivers
- Allows real-time platform position and attitude accuracy to 1 m and 20 arc sec, post-processing accuracy to 3 cm and 5 arc sec
- Contributes to developing centimeter-level global geodesy, high-precision atmospheric temperature profiling, ionospheric gravity wave detection, and 3-D ionospheric tomography

William Melbourne received his A.B. degree with highest honors in Astronomy-Physics from the University of California, Los Angeles, in 1954, and his Ph.D. degree in Astronomy from the California Institute of Technology in 1959. He joined Jet Propulsion Laboratory in 1956 and during the 1960s and 70s either served as major architect for, or directed the development of, numerous navigation and radio science systems and pioneered their application to geodynamics. Over the past nine years, he has led NASA's

program at JPL to develop a sub-decimeter-accuracy GPS-based tracking system for Earth-orbiting missions and a GPS-based geodetic system for centimeter accuracy crustal deformation measurements. He is currently Assistant Division Manager for Metric Tracking in the Telecommunications Science and Engineering Division. He is also the Geodynamics Program Manager for the Office of Space Science and Instruments.

George K. Parks

The objectives of the X-Ray Imaging Experiment and the optional particle detectors are to detect and determine the total particulate energy that is precipitated into the Earth's atmosphere. The x-ray instrument system consists of a proportional gas-filled counter for detecting 3 to 20 keV x-rays and an Anger camera for detecting and imaging 20 to 200 keV x-rays. The optional particle detector system consists of electrostatic analyzers and solid-state telescopes which will detect electrons from a few eV to several hundred keV and protons from a few eV to several hundred MeV. This combined package will provide information on: 1) the total x-ray fluxes impinging

X-ray Imaging Experiment

on the Earth's atmosphere; 2) energy spectra of these x-rays; 3) presence of different energy spectral components, including the hard x-ray components that reach the lower atmosphere near the tropopause; 4) images of x-rays, which provide space and time information on their sources; and 5) primary electron and ion distribution functions, from which macroscopic parameters such as density, convective velocities, and temperatures are obtained. These data will permit comprehensive modeling studies of thermodynamic, chemical, electrical, and meteorological effects on Earth due to the deposition of particle energy.

XIE - X-RAY IMAGING EXPERIMENT

- X-ray pinhole "anger" cameras with NaI (T1) and PM detectors for > 20 keV x-rays proportional gas-filled counter for 3-20 keV x-rays
- Optional particle package, electrostatic analyzers (for electrons and protons from a few eV to 30 keV) and solid-state telescopes for electrons (20-450 keV) and protons (20 keV to tens of MeV)
- Field of view $\pm 56^\circ$ (x-rays), $\pm 90^\circ$ (particles)

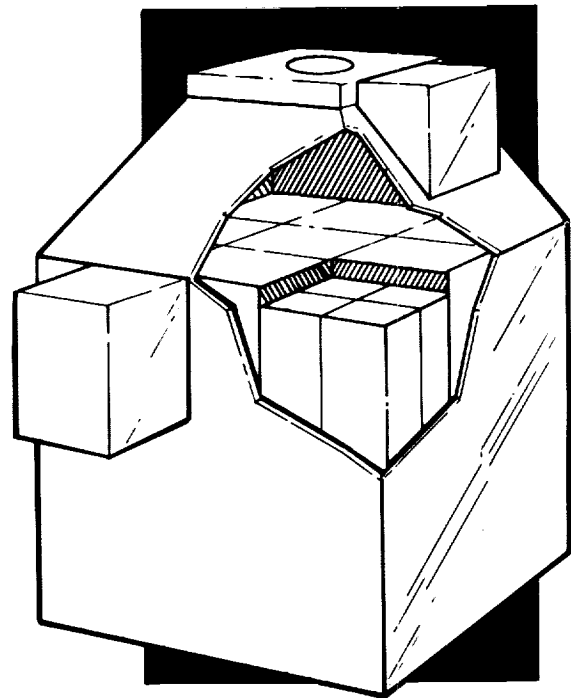

George K. Parks received his B.A. and Ph.D. in Physics from the University of California, Berkeley. Dr. Parks spent three years as a Research Associate at the Physics Department of the University of Minnesota after earning his Ph.D. degree and was Professeur Associe at the University of Toulouse, France, before he joined the faculty at the University of Washington,

Seattle, in 1971. He is currently Professor in the Geophysics Program and Adjunct Professor in the Atmospheric Sciences and Physics Departments at that institution. Dr. Parks has worked on several past NASA missions, ATS-6 and ISEE, and is currently a Co-Investigator on the GGS/ISTP Program.

TRACER

Henry G. Reichle, Jr.

TRACER is designed to measure the global distribution of CO at multiple levels in the troposphere and thus provide a global data base for modeling studies that will increase understanding of global tropospheric chemistry and transport processes, as well as CO mixing ratios and geographical distribution within layers versus time. The instrument is a nadir-viewing gas-filter radiometer operating in the 2.3 μm and

Tropospheric Radiometer For Atmospheric Chemistry And Environmental Research

4.6 μm spectral regions using a technique similar in principle to the MAPS (Measurement of Air Pollution from Satellites) instrument first flown on the space shuttle in November 1981. TRACER implements the gas-filter technique differently by taking advantage of the latest advances in digital electronic technology, thereby reducing optical complexity.

TRACER OPTICAL SCHEMATIC

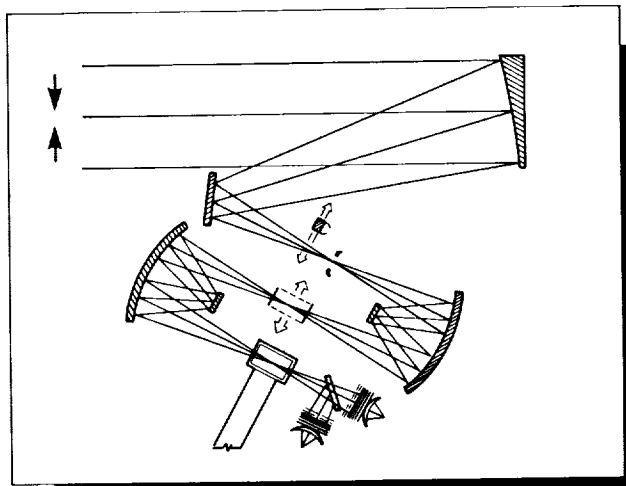

- Two-channel gas-filter correlation radiometer
- Nine separate filters contained in rotating gas-cell chopper
- 2.3 micrometer radiance of CO and CH₄
- 4.6 micrometer radiance of CO and N₂O

Henry Reichle was educated at the University of Michigan, receiving degrees in aeronautical engineering (B.S.), instrumentation engineering (M.S.), meteorology (M.S.), and aeronomy (Ph.D.). Dr. Reichle has been affiliated with Langley Research Center since 1962 and currently serves as a Senior Research Scientist. He has been active in research on the remote measurement of

atmospheric properties for nearly 25 years; his efforts have concentrated on the development of nadir-viewing techniques using the middle-infrared portion of the spectrum for the measurement of the properties of the troposphere. As Principal Investigator, he directed the development of the MAPS experiment, which was flown on the space shuttle during 1981 and again in 1984.

SOLSTICE

Gary Rottman

Solar Stellar Irradiance Comparison Experiment

SOLSTICE provides precise daily measurements of the full disk solar ultraviolet irradiance between 4 to 440 nm. (Two solar spectral resolutions are required to fully determine and understand the energy input into the different layers of Earth's atmosphere.) Bright early-type stars will be used for very stable, in-flight calibrations, assuring an

accuracy better than 1% throughout the entire Eos mission. The SOLSTICE instrument consists of a four-channel spectrometer together with the required gimbal drive to point SOLSTICE at the sun and stellar targets and is similar to the UARS SOLSTICE instrument, scheduled to launch in 1991.

THE SOLSTICE INSTRUMENT

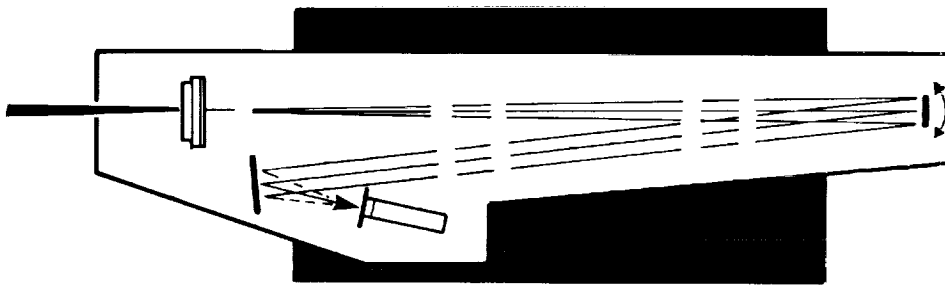

- Four-channel UV spectrometer (two-axis solar track)
- Daily measurement of full disk solar irradiance, with calibration maintained by comparison to bright, early-type stars (1% accuracy)
- Range of 115 to 440 nm
- Three-channel spectral resolution to 0.2 nm; one channel to 0.0015 nm

Gary Rottman, who holds his M.S. and Ph.D. degrees in physics from The Johns Hopkins University, has concentrated his professional career at the University of Colorado. He is presently Senior Research Associate in the institution's Laboratory for Atmospheric and

Space Physics. His space research includes roles as Principal or Co-Investigator on numerous solar-mesosphere investigations, including Solar-Mesosphere Explorer, SOLSTICE/UARS Program, and Solar EUV SPARTAN and Rocket Programs.

James M. Russell III

The goal of the Spectroscopy of the Atmosphere using Far Infrared Emission (SAFIRE) experiment is to achieve a major improvement in our understanding of the middle atmosphere ozone distribution by conducting global-scale measurements of the important chemical, radiative, and dynamical processes which influence ozone changes. SAFIRE is a passive limb emission, multi-channel spectrometer-radiometer that combines the advantages of a seven-channel far-IR Fourier transform spectrometer (0.004 cm^{-1} spectral resolution) and a space-proven seven-channel mid-IR broadband-

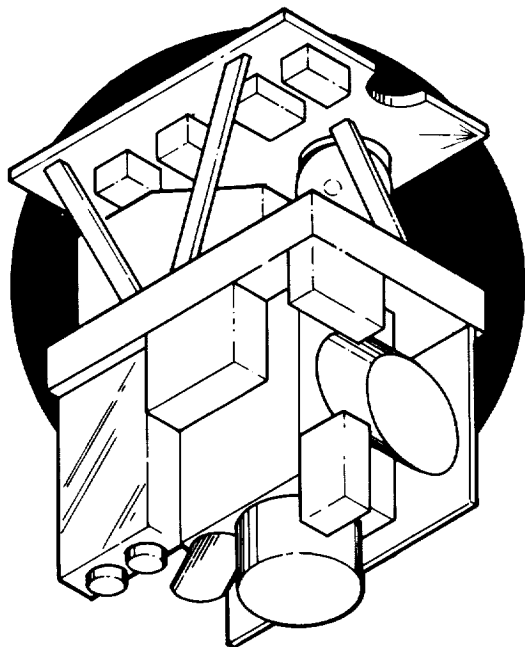

Dr. Russell received his Ph.D. in Aeronomy from the University of Michigan. He presently serves as Head of the Theoretical Studies Branch, Atmospheric Sciences Division at the Langley Research Center. Since 1970, he has concentrated on atmospheric science and remote sensing research. He served as Co-Team Leader of LIMS, launched on Nimbus-7 in 1978; Co-Investigator on Spacelab 3 ATMOS experiment,

Spectroscopy Of The Atmosphere Using Far Infrared Emission

type radiometer. The instrument brings together, for the first time, simultaneous observations by one instrument of key HO_y, NO_y, ClO_y, and BrO_y gases, coupled with dynamical tracer measurements. Some important applications of the data include study of: (1) major processes in the main chemical families; (2) polar night chemistry; (3) non-local thermodynamic equilibrium; (4) diurnal changes in key gases; (5) dynamics and transport processes; (6) chemistry and dynamics coupling; and (7) lower stratospheric phenomena.

SAFIRE INSTRUMENT MOCK-UP

- Seven-channel far-IR Fourier transform spectrometer (0.004 cm^{-1} spectral resolution)
- Seven-channel mid-IR broadband LIMS-type radiometer
- Covers spectral ranges 80-160, 310-390, and 630-1,560 cm^{-1}
- Sensor modules optically coupled through common telescope
- LIMS-type adaptive CO₂ horizon sensing used for primary attitude reference; fore and aft viewing provides nearly complete global coverage (86 N to 86 S)

launched on Shuttle in 1985; and he is Principal Investigator on HALOE and Co-Investigator on ISAMS scheduled to fly on UARS in 1991. He has been a Visiting Scientist at NCAR, is listed in several biographical periodicals which recognize achievement in science, has received the NASA Medal for Exceptional Scientific Achievement, and holds two U.S. patents.

HIMSS

Roy W. Spencer

The High-resolution Microwave Spectrometer Sounder (HIMSS) will be used for the retrieval of numerous atmospheric and oceanic parameters, including precipitation rates over both land and ocean in multiple layers, oceanic cloud water and water vapor content, wind speed and sea surface temperatures, atmospheric temperature profile, snow cover depth and water equivalent, and possibly vegetation. This instrument will build upon the successful heritage of the Special

High-Resolution Microwave Spectrometer Sounder

Sensor Microwave/Imager (SSM/I), with special emphasis on instrument design that provides: (1) an accurate and stable calibration design to allow meaningful monitoring of Earth and atmospheric processes on time scales of many years, (2) swath width improved over current microwave radiometers, (3) order-of-magnitude improvement in footprint areal resolution, (4) high radiometric sensitivity, and (5) co-located footprints.

HIMSS VIEWING GEOMETRY, POLAR PLATFORM

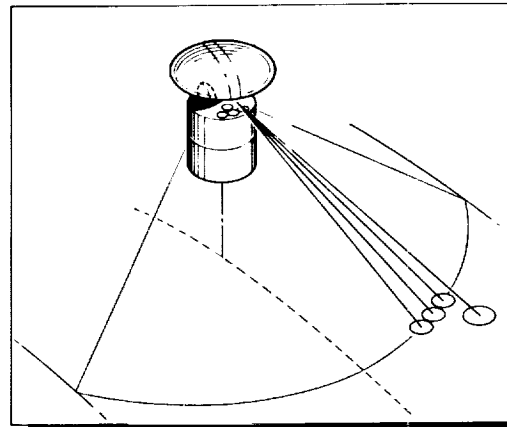

- High-resolution microwave spectrometer
- Frequencies between 6.6 and 90 GHz
- Measures precipitation rate, cloud water, water vapor, temperature profiles, sea surface roughness, SST ice, and snow
- Resolution varies from 5 km at 90 GHz to 50 km at 6.6 GHz
- 2 m parabolic antenna and rotating drum (30 rpm)
- Heritage SSM/I instrument

Roy W. Spencer received his B.S. degree in atmospheric science from the University of Michigan, and both the M.S. and Ph.D. degrees in meteorology from the University of Wisconsin. Currently, Dr. Spencer is a Space Scientist at the Marshall Space Flight Center, where he directs a program of satellite passive microwave data analysis from the DMSP SSM/I, the Nimbus-7 SMMR, and the MOS-1 MSR; and the

development and flight of a high-altitude aircraft five-frequency scanning microwave radiometer. Dr. Spencer has been a member of several NASA-sponsored committees, including the Tropical Rainfall Measuring Mission Science Steering Group, the Earth Science Geostationary Platform Committee, and the Earth System Science Subcommittee on Winds and Precipitation.

EOSP

Larry D. Travis

The Earth Observing Scanning Polarimeter (EOSP) is a high-precision, multi-channel, scanning photopolarimeter designed to obtain global maps of the radiance and degree of linear polarization for 12 spectral bands in the visible and near-infrared in order to: (1) determine cloud properties including optical thickness, particle size, liquid/ice phase, and cloudtop pressure; (2)

Earth Observing Scanning Polarimeter

determine global distribution of the tropospheric and stratospheric aerosols; (3) provide atmospheric correction information for ocean and land observation; and (4) investigate the potential for providing information on vegetation and land characteristics. These scientific objectives complement and support a number of the principal objectives of the MODIS experiment.

CUTAWAY VIEW
OF EOSP

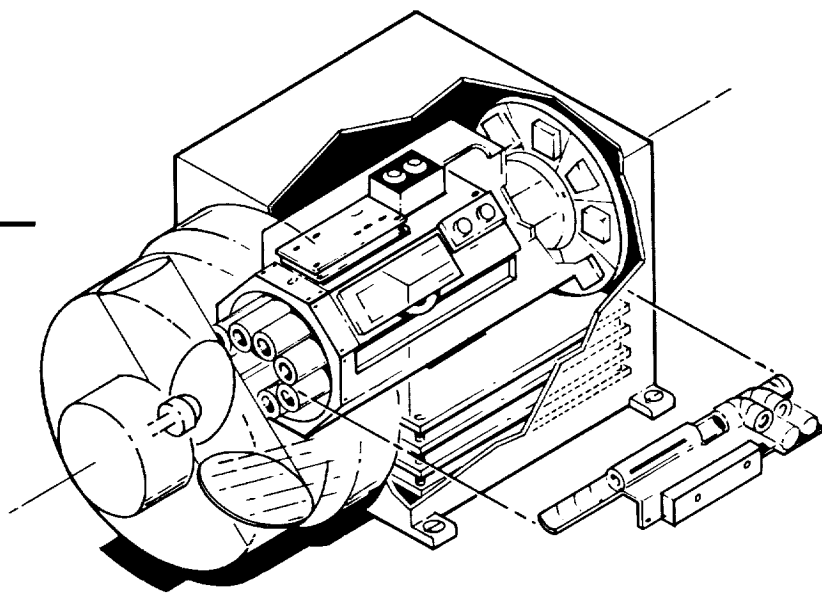

- Cross-track scanning polarimeter
- Simultaneously measures radiances and degree of polarization in 12 spectral channels from 410 to 2,250 nm
- 10 km IFOV
- Provides cloud properties such as optical thickness and phase, and global aerosol distribution

Larry D. Travis received his Ph.D. in 1971 from the Pennsylvania State University. He is currently the Associate Chief at the NASA Goddard Institute for Space Studies. His research interests include radiative transfer in planetary and stellar atmospheres, convective energy transport, single and multiple scattering theory, theoretical interpretation of planetary polarization; satellite

platform measurements of planetary polarization, and spin-scan imaging and analysis of planetary cloud systems. Dr. Travis serves as Principal Investigator for the Pioneer Venus Cloud Photopolarimeter Experiment and as a Co-Investigator for the Galileo Photopolarimeter Radiometer Experiment.

MLS

Joe W. Waters

The objective of the Microwave Limb Sounder (MLS) investigation is to study and monitor processes which govern stratospheric and mesospheric ozone, with emphasis on potential ozone depletion by mankind's increasing industrial activities. Molecules in all ozone destruction cycles are to be measured, including all radicals now thought to control the rate at which upper stratospheric ozone is destroyed. Scientific information from the measurements will include trend detection, chemistry, dynamics, and

Microwave Limb Sounder

climatology of the stratosphere and mesosphere, and will be used in a variety of ways to constrain and test models of stratospheric and mesospheric photochemistry and dynamics. The Eos MLS instrument--an enhanced version of the UARS MLS--measures molecular thermal emission spectra at millimeter and submillimeter wavelengths as its field-of-view is vertically scanned through the atmospheric limb in the orbit plane. All measurements are performed simultaneously and continuously.

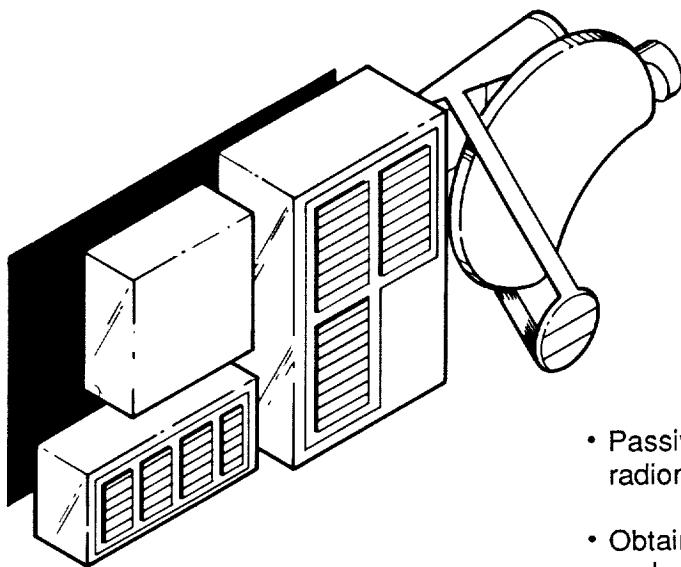

**THE MLS
INSTRUMENT**

- Passive microwave limb-sounding radiometer
- Obtains vertical profiles of all molecules and radicals believed to be involved in the ozone destruction cycle
- Measurements in three spectral bands: 637, 560, and 205 GHz
- Spatial resolution 100 km x 3 km x 6 km
- Gimbaled antenna

Dr. Waters has led the development of microwave limb sounding for 15 years. He originated the technique in 1973 and, since then, has been Principal Investigator on aircraft, balloon, and UARS MLS experiments. His Ph.D. degree is from the Massachusetts Institute of Technology

Electrical Engineering Department, where he was a Co-Investigator on Nimbus-5 and Nimbus-6 microwave spectrometer experiments. He has authored 28 papers in refereed scientific journals, most on microwave remote sensing of Earth's atmosphere.

ACRIM

Richard C. Willson

The Active Cavity Radiometer Irradiance Monitor (ACRIM) experiment is designed to implement an "overlap strategy" with earlier ACRIM experiments and within the Eos mission itself, that is required to sustain the NASA long-term solar luminosity database throughout the Eos mission timeframe. The primary objective of ACRIM is to monitor the

Active Cavity Radiometer Irradiance Monitor

variability of total solar irradiance with state-of-the-art accuracy and precision thereby extending the high-precision database compiled for NASA since 1980 by other ACRIM experiments as part of the earth radiation budget "principal thrust" in the National Climate Program.

THE ACRIM INSTRUMENT

- Three total irradiance detectors
- One sensor monitors solar irradiance fulltime; two sensors calibrate optical degradation of first sensor
- SI uncertainty of 0.1%, long-term precision of 5 ppm per year
- Sensor assembly mounted on two-axis tracker to observe solar disk during each orbit

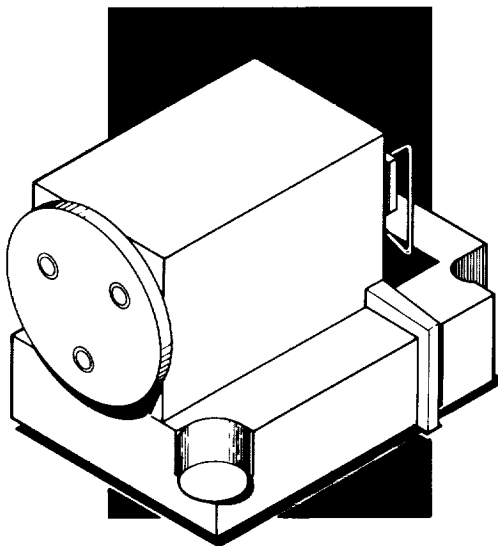

Richard C. Willson holds the doctoral degree in atmospheric sciences from the University of California, Los Angeles and B.S. and M.S. in physics from the University of Colorado. He is a member of the technical staff and Supervisor of the Solar Irradiance Monitoring Group, Atmospheric and Cometary Sciences Section, Earth and Space Sciences Division at JPL. His career, which began at JPL in 1963, has been

involved primarily with development of state-of-the-art Active Cavity Radiometer pyrheliometry for use in solar total irradiance observations on balloon, sounding rocket, space shuttle, and satellite platforms. He has been the Principal Investigator for the Solar Maximum Mission ACRIM 1, space shuttle Spacelab 1, ATLAS I and ATLAS II/ACR, and Upper Atmosphere Research Satellite ACRIM II experiments.

INTERDISCIPLINARY INVESTIGATIONS

Abbott, Mark R.
Barron, Eric J.
Bates, J. Ray
Batista, Getulio T.
Brewer, Peter G.
Cihlar, Josef
Dickinson, Robert
Dozier, Jeff
Grose, William L.
Gurney, Robert J.
Hansen, James
Harris, Graham P.
Hartmann, Dennis L.
Isacks, Bryan L.
Kerr, Yann H.
Liu, W. Timothy
McNutt, Lyn
Moore, Berrien
Mouginis-Mark, Peter
Murakami, Masato
Pyle, John Adrian
Rothrock, Drew
Schimel, David M.
Schoeberl, Mark R.
Sellers, Piers
Srokosz, Meric A.
Tapley, Byron
Wielicki, Bruce

Mark Abbott

Dr. Abbott's study concerns dynamics of the Southern Ocean--its circulation, biology, and interaction with the atmosphere--and proposes large-scale studies including atmospheric forcing, ocean circulation, and primary production. In addition, techniques will be explored to cope with strong eddy activity in the Southern Ocean, and to incorporate inherently nonlinear biological processes into physical models. There are two main goals: First, it will be possible to understand the processes that regulate atmospheric and oceanic heat and momentum flux in the Southern Ocean and how they vary in time and space. Second, it will be possible to understand the temporal and spatial patterns of primary production and how they are regulated by physical forcing, and how these patterns are coupled with fluxes of biogenic carbon.

Coupled Atmosphere/Ocean Processes And Primary Production In The Southern Ocean

Dr. Abbott has been involved in the fields of oceanography and ecology for 11 years. He received his undergraduate degree in the conservation of natural resources from the University of California at Berkeley and the Ph.D. degree in ecology from UC, Davis. He has been affiliated with Oregon State University since 1988, currently as Associate Professor in the College of Oceanography. Dr. Abbott has served on numerous Eos-related committees, including the Eos Science Steering Committee, the Moderate Resolution Imaging Spectrometer Panel, the Imaging Spectrometer Science Advisory Group, and the NASA/NOAA Convergence Panel. Dr. Abbott has also been selected as a MODIS Team Member.

Eric J. Barron

This study focuses on the global water cycle to determine the scope of its interactions with all components of the Earth system and to understand how it stimulates and regulates change on both global and regional scales. Dr. Barron plans to effect the conversion of patterns observed from space into knowledge of the processes that, linked together, determine the evolution of water in the Earth system. Research strategy involves developing a hierarchy of simulation models that assimilate Eos observations and produce information on physical and biological variables and process rates. The models will be tested with field studies that yield calibration and verification and, over the definition phase, will provide a methodology for resolving the presently unknown sources, sinks, and flux rates of the global water cycle. These will then be used to document significant aspects of the water

Global Water Cycle: Extension Across The Earth Sciences

cycle and to develop the knowledge necessary to understand past variations and predict them in the future.

Dr. Barron received M.S. and Ph.D. degrees in oceanography and climatology from the University of Miami and was a postdoctoral fellow at NCAR. Dr. Barron joined Penn State as the Director of the Earth System Science Center and Associate Professor of Geosciences in 1986. His research interests focus generally on global change and more specifically on numerical models of the climate system and the study of change throughout history. He is a member of numerous working groups related to these interests and, in addition, serves as Editor-in-Chief of Palaeogeography, Palaeoclimatology and Palaeoecology, and as Editor of Global Planetary Change.

J. Ray Bates

Dr. Bates plans to develop and maintain a high-resolution, four-dimensional atmosphere/ocean/land data assimilation system for the Earth Observing System. The project will involve research on all aspects of four-dimensional data assimilation (satellite retrievals, data quality control, objective analysis, initialization, and atmosphere/oceanic/land surface models), with dual objectives of extracting the maximum amount of information and understanding possible from Eos data and building the foundation for a future "Earth System Model." Diagnostic studies will be carried out with the data produced by this assimilation system, emphasizing global hydrological cycle and low-frequency atmospheric and oceanic variability. At the start of the Eos execution phase, the researchers hope the assimilation system will be capable of becoming the main vehicle for the delayed-mode production

The Development And Use Of A Four-Dimensional Atmospheric/Ocean/Land Data Assimilation System For Eos

by EosDIS of integrated atmosphere/ocean/land data sets in the horizontal scale of several tens of kilometers.

J. Ray Bates has over 25 years experience in meteorological research. A native of Ireland, Dr. Bates began his career with the Irish Meteorological Service and, after obtaining his Ph.D. degree at MIT in 1969, returned to that Service's Research Division. He has worked abroad on leave of absence on numerous occasions and since 1987 has served as Senior Research Associate in the Department of Meteorology at the University of Maryland. Dr. Bates was awarded the Napier Shaw Memorial Prize of the Royal Meteorological Society in 1971 and was elected to membership of the Royal Irish Academy in 1986.

Getulio T. Batista

Amazonia is unique among terrestrial ecosystems for its spatial extent, the intimate interaction with the largest river on our planet, and the rate of change caused by human activity. Dr. Batista's program now combined with the proposal submitted by Dr. Jeffrey Richey from the University of Washington, "The Regional Amazon Model: Synoptic Scale Hydrological and Biogeochemical Cycles from Eos," will attempt to describe the routing of water and its chemical load from precipitation to the main channel and ocean through the drainage system under conditions of changing land use in the Amazon. Dr. Batista's team will model, for a large basin, the relationship between deforestation rates and the hydrological water cycle on a yearly basis. They will also model eutrophication processes and sediment transport for selected tributaries and reservoirs

Long-Term Monitoring Of The Amazon Ecosystems Through The Eos: From Patterns To Processes

with differential land-use pressures employing Eos data.

With degrees in agronomy and remote sensing (Ph.D. 1981, Purdue University), Dr. Batista has focused his research in the areas of crop identification and conditions assessment, yield prediction modeling, scene characteristics and classification accuracy, and crop field radiometry. Since 1971 he has been affiliated with the Brazilian Institute for Space Research (INPE). He was the Head of the Remote Sensing Department from 1982 to 1987, Deputy Director of their Remote Sensing Directorate from 1985 to 1987, and recently was the Principal Investigator of PEPS Program of the SPOT satellite for tropical agriculture.

Peter G. Brewer

Dr. Brewer proposes to investigate the fate of solar radiation incident on the oceans with its pronounced chemical, physical, and biological consequences, and the feedback of the gaseous products of these interactions through the agency of wind, waves, and circulation to the marine atmosphere. The topics involved include oceanic photochemistry, pigments, ocean biological processes, surface slicks and chemical modification of surfaces, surface waves and momentum transfer, and biogenic gas fluxes and their linkage through models. The overarching theme is to derive Earth-scale constraints in these important processes through the combination of local data sets with satellite imagery. A further benefit will be the construction of global-scale views of critical processes from the complex interplay of field data and satellite observables. Cooperation with major field programs such as JHOFS and WOCE will be involved.

Biogeochemical Fluxes At The Ocean/Atmosphere Interface

Dr. Brewer received his undergraduate and Ph.D. degrees from Liverpool University and has over 20 years experience in oceanography and marine chemistry. Since 1967 he has been affiliated with the Woods Hole Oceanographic Institution, presently as Senior Scientist and is author, or co-author, of more than 70 scientific papers. From 1981 to 1983 he also was Program Director of Marine Chemistry at the National Science Foundation and, in addition to teaching duties at W.H.O.I., has chaired or served on numerous committees concerning marine research and global studies, as well as serving as editor or associate editor of related journals. Dr. Brewer's current research focuses on the global carbon cycle. He serves as Chairman of the U.S. Global Ocean Flux Study, and Vice Chairman of the International Joint Global Ocean Flux Study. He is a Fellow of the American Geophysical Union.

Josef Cihlar

Addressing issues related to the role of terrestrial vegetation at mid and high latitudes, this investigation builds on work accomplished or planned in Canada. It will carry out the research, development, and demonstration of a Vegetation Change Information System (VCIS) to routinely monitor terrestrial vegetation from space. Initial model development, algorithm development, and output generation (e.g., a vegetation map of Canada) will be done prior to Eos launch. Eos data will be optimized and applied over the Canadian landmass using the VCIS, and vegetation growth models will be developed to produce digital maps of net change in carbon storage for two different years after Eos launch. Also to be developed are one or more succession models and digital maps of future vegetation

Quantifying The Vegetation Of Canada: Carbon Budget And Succession Models

distribution over Canada, based on observed or postulated changes in environmental conditions.

Dr. Cihlar holds degrees in soil science and physical geography and remote sensing (Ph.D. University of Kansas, 1975), and has concentrated his research interests on renewable resources and data acquisition and analysis for land applications. He joined the Canada Centre for Remote Sensing (CCRS) in 1975 as Environmental Scientist. Since 1979, he has been responsible for applications development at CCRS. Dr. Cihlar is presently involved in planning the use of space observations for global change studies. He leads the Remote Sensing Technical Group reporting to the Royal Society of Canada, and is a member of the IGBP Working Group on Data and Information Systems.

Robert Dickinson

Dr. Dickinson's proposed study involves modeling, data analysis, data systems, and archiving, all directed toward improvements of global and mesoscale climate models at the National Center for Atmospheric Research. Sensitivity studies of the application of Eos data to model improvement will be carried out for several focused areas including the land-surface component of the models in a global and regional context; the sea-ice component; the role of clouds; and atmospheric profiles of latent-heat release. Also proposed are long-term monitoring of atmospheric properties from operational satellite data, links between Eos sensor systems and model-generated fields, data visualization and archiving in the context of model requirements, application of surface remote-sensing technology to image processing of the required satellite data, maintenance of an Eos data archive, and exploration of new methodologies for organizing and archiving global data sets.

NCAR Project To Interface Modeling On Global And Regional Scales With Earth Observing System Observations

Dr. Dickinson has been affiliated with the National Center for Atmospheric Research since 1968; presently he is Deputy Director of the Climate and Global Dynamics Division. He has served as Visiting Professor or Guest Lecturer at several western state universities, serves as Principal Investigator on studies supported by USGS and NASA concerned with climate modeling, and is a member of the U.S. National Academy of Sciences and is active in efforts of the National Research Council, the American Geophysical Union, the International Geosphere Biosphere Programme, the World Climate Research Programme, and the American Meteorological Society. He has over 150 refereed publications to his credit. Finally, he is a Fellow of the American Association for the Advancement of Science, the American Geophysical Union, and the American Meteorological Society, and was awarded the AMS Jule G. Charney Award in 1988.

Jeff Dozier

The snow hydrology of alpine areas is an important component of the global hydrologic cycle because of the large volumes of water stored in these reservoirs in the winter season, the sensitivity of the winter snowpack to climatic change, and the complex role of snow processes in acidic deposition. The overall objective and anticipated result of Dr. Dozier's investigation is a detailed understanding of the patterns and processes of the water balance and chemical and nutrient balances of seasonally snow-covered alpine watersheds. Image data from several Eos facility instruments will be used to monitor hydrologic conditions in selected watersheds and to drive hydrologic models. Hydrological and chemical sampling will be done in the field, and data will also be collected from other government programs currently investigating the effects of atmospheric pollutants on high-elevation watersheds. Results will be extended spatially through combination with hydrologic measurements.

Hydrology, Hydrochemical Modeling and Remote Sensing In Seasonally Snow-Covered Alpine Drainage Basins

With undergraduate and doctoral degrees in geography (Ph.D. University of Michigan, 1973), Dr. Dozier has concentrated his research on snow hydrology and related studies in radiative transfer and remote sensing, especially on interpretation of snow properties from the Landsat TM. Since 1974 he has taught at the University of California, Santa Barbara, where he is now the Professor of Geography. For the past two years he has held a joint appointment as a Senior Member of Technical Staff at JPL. He is Project Scientist for JPL's HIRIS, was selected as a HIRIS Team Member, and chairs the EosDIS Data Advisory Panel. He served on the Eos Committee on HMMR, and he is a NASA Principal Investigator on the first ISLSCP field experiment and on the Shuttle Imaging Radar-C, as well as on the California Air Resources Board's Integrated Watershed Study. He also chairs the National Academy of Science's Committee on Glaciology and the AGU's Committee on Snow, Ice, and Permafrost, and he is the Associate Editor of Water Resources Research.

William Grose

Dr. Grose's team will focus on providing increased understanding of the radiative, chemical, and dynamical processes which determine the circulation, thermal structure, and distribution of constituents of the Earth's atmosphere. Emphasis will be placed on examining interactive coupling among these processes. The investigation will be conducted through observational analysis and diagnostic interpretation of meteorological and constituent data from Eos instruments, in conjunction with satellite, balloon, ground-based, and aircraft data. Also, atmospheric simulation studies will be conducted with a hierarchy of models incorporating radiative, chemical, and dynamical processes to varying degrees of complexity for the troposphere, stratosphere, and mesosphere.

Observational And Modeling Studies Of Radiative, Chemical and Dynamical Interactions In The Earth's Atmosphere

William Grose received his M.S. degree in physics from the College of William and Mary and the Ph.D. degree in Aerospace Engineering from Virginia Polytechnic Institute and State University. He is Senior Research Scientist and Assistant Head of the Theoretical Studies Branch, Atmospheric Sciences Division at the Langley Research Center. He has participated in the development of several 3-D models for studies of atmospheric dynamics and transport. He is Principal Investigator for a current NASA modeling and observational analysis study, as well as Principal Investigator and member of the UARS study team. Dr. Grose was a Visiting Scientist with the United Kingdom Universities' Atmospheric Modeling Group and the University of Reading, England. He was recipient of the NASA Medal for Exceptional Scientific Achievement in 1986.

Robert James Gurney

Dr. Gurney's research objective is to use Eos and other data to estimate global water balances for days to seasons, and to examine their variability over decades with various external forcings. Several complementary models for estimating components of the daily and long-term water budget will be implemented or calibrated using Eos data, and new combined models--that can be applied globally for the first time--will be developed. Estimates of monthly water balances for continental-scale areas will be produced. These estimates will be checked in selected areas through conventional data.

Estimation Of The Global Water Budget

Robert Gurney has concentrated his research experience in hydrological modeling. After receiving his Ph.D. degree from the University of Bristol, he was affiliated with the Institute of Hydrology in Wallingford, England. Since 1981 he has worked with NASA's Goddard Space Flight Center, within the Hydrological Sciences Branch, and is currently Head of that Branch. Dr. Gurney has served as Principal Investigator on numerous NASA and European Space Agency projects, and was a Deputy Study Scientist for Eos and member of the Eos Science Steering Committee. He has also served as Editor for a book series on remote sensing and is an Associate Editor of *Water Resources Research*.

James E. Hansen

Dr. Hansen's team will investigate the interannual variability of key global parameters and processes in the global carbon cycle and the global thermal energy cycle. They will develop, analyze, and make available global geophysical data sets derived from pre-Eos and Eos observations in combination with models. Developing data sets will involve use of observations in combination with global models that are already developed or under development. Analysis will involve studies of several specific interdisciplinary problems, each focused on interactions among components of the Earth system. Expected near-term products are 1) knowledge of certain Earth system processes which can be investigated via large-scale interannual variability of a number of observed parameters, 2) a mini Eos-type collection of data sets available in convenient form to other

Interannual Variability Of The Global Carbon and Energy Cycles

investigators, and 3) Improved definition of global measurement and data set needs for Eos.

Dr. Hansen heads the Goddard Institute for Space Studies. A student of astronomy and physics (Ph.D. University of Iowa, 1967), he has focused his research primarily on radiative transfer in planetary atmospheres and related interpretation of remote sounding, development of simplified climate models and 3-D global models, and the study of climate mechanisms. He has been involved on several photopolarimeter experiments such as AEROPOL, Voyager, Pioneer, and Galileo, and, in addition to his research and administrative duties, he serves as Adjunct Professor at Columbia University. Dr. Hansen is a well-known expert witness on current climate trends and has been instrumental in heightening awareness of man's impact on climate (the greenhouse effect).

Graham Paul Harris

This interdisciplinary investigation concerns a breadth of activities going all the way from basic to applied research, all of which are concerned with interannual variability in climate, biological processes, ocean-atmosphere interactions, and the marine fisheries resources. Dr. Harris plans to study the links between these processes in Australasian waters and fisheries. There is an important set of interactions to be examined between climatic El Nino/Southern Oscillation events and ocean processes as well as a need for studies of oceanic productivity in tropical waters and the subtropical convergence region south of Australia and New Zealand. Further examination is suggested of these interactions using existing satellite data, data from new sensors, and Eos polar platform data. Suitable algorithms should be developed at all stages to measure phytoplankton biomass and productivity from space. At longer time scales, there is an important feedback between ocean productivity and global change, because the subtropical

Interdisciplinary Studies Of The Relationships Between Climate, Ocean Circulation, Biological Processes, and Renewable Marine Resources

convergence region of the Southern Hemisphere is one of the most important sites of "new" production in the world ocean.

With academic preparation in biology and ecology (Ph.D. Imperial College, London, 1969), Graham Harris has dedicated his career to the interaction of physical and biological processes and their effect on aquatic resources. He worked in the Great Lakes (Canada) from 1969 to 1983 and began his remote sensing career with the ERTS-1 simulation missions. Since 1984 he has been affiliated with Australia's CSIRO Divisions of Fisheries Research and Oceanography, first as Programme Leader and now Head of the Fisheries Remote Sensing Group. Dr. Harris chairs the Australian National Committee for Ocean Sciences; is Chair or member of numerous advisory committees and working groups on oceans remote sensing, including the Australian Polar Platform Planning Committee; and is member of editorial boards of publications on marine ecology and oceanography.

Dennis L. Hartmann

The goal of Dr. Hartmann's investigation is to use data from various satellite instruments, data from other sources, and models to construct an integrated view of the atmospheric climate over the oceans. The physical processes considered will include boundary layer dynamics and resulting fluxes, cloud-scale and mesoscale dynamics, and cloud physics, interactions between clouds and radiative fluxes and interactions between scales of motion from the scale of boundary layer turbulence to the largest scales of planetary motion. An understanding of the climate which incorporates the interactions among all of these processes and scales is necessary to predict future changes in the climate. Simultaneous measurements of a variety of physical variables that can be derived from Eos measurements will be utilized to better understand the atmosphere

Climate Processes Over The Oceans

portion of the climate system and its interactions with the ocean.

Dennis Hartmann received his Ph.D. degree in geophysical fluid dynamics from Princeton University in 1975. He has been on the faculty of atmospheric sciences at the University of Washington since 1977, attaining the rank of Professor in 1988. His main research interests are in the areas of global climate, large-scale dynamics, and the radiative energy balance of the Earth; he has published extensively on the topics of low-frequency variability in the atmosphere. Dr. Hartmann served as Principal Investigator in the Earth Radiation Budget Experiment (ERBE) and the Airborne Antarctic Ozone Experiment (AAOE). He currently is a member of the Committee on Earth Sciences of the Space Science Board of the National Research Council.

Bryan L. Isacks

Dr. Isacks plans to focus on the Andean Orogen and examine the interplay of climate, weathering, mountain building, and rapid plate boundary interaction. Data generated from satellite imagery and refined by Eos Altimetry, plus HIRIS, MODIS, and SAR images, will be entered into a comprehensive Morphotectonic Information System. The system allows retrieval of all geocoded spatial data and site-specific information with an advanced computer graphics interface; digital elevation models will be constructed using these data as well. The results could be a fundamentally new approach to geologic research including a new kind of systems science that integrates continental crustal evolution, magmatism, tectonics, and climatic geomorphology as a complete geologic description of an active orogen.

Tectonic/Climatic Dynamics And Crustal Evolution In The Andean Orogen

Bryan L. Isacks has 27 years experience in the fields of geology and geophysics with special concentration on seismology and tectonics. He earned both undergraduate and doctoral degrees in geology from Columbia College and University. Following tenure as a Research Geophysicist at Lamont Geological Laboratory, Dr. Isacks joined Cornell University in 1971 where he is currently the William and Katherine Snee Professor of Geological Sciences. He has served as Chairman of the Geophysical Division of the Geological Society of America, on the Board of Directors of the Seismological Society of America, and as Associate Editor of the Journal of Geophysical Research.

Yann H. Kerr

Recent droughts in the Sahelian regions of Africa and Nordeste Brazil, and tropical rain deforestation emphasize the urgency of an accurate monitoring of natural or anthropogenically-induced changes in land-surface parameters and of improving the understanding of the Earth/atmosphere response to changes in land surface characteristics. Dr. Kerr's investigation relies on several sensors on the polar platform to derive hydrologic cycle parameters over arid and semi-arid lands. The thrust of his research is to define a global data set and to develop algorithms/models giving actual geophysical parameters. These parameters--which would actually be used to monitor seasonal and year-to-year changes--include surface temperature, roughness, moisture, vegetation characteristics, evapotranspiration, rainfall, short-wave incoming flux, and albedo. Soil/vegetation interactions and hydrological feedback mechanisms will also be studied.

Hydrologic Cycle - Semi-Arid Areas - Climatologic Processes

Dr. Kerr received an Engineering Degree from the Ecole Nationale Supérieure de l'Aéronautique et de l'Espace (ENSAE, Toulouse, France), and the M.Sc. degree from Glasgow University (Glasgow, UK), and a Ph.D. from the Université P. Sabatier (Toulouse, France, Summer 1989). From 1980 to 1985 he was with the Centre National d'Etudes Spatiales (Toulouse, France). In 1985 he joined the LERTS as a research scientist. From May 1987 to December 1988 he worked (on leave of absence) at Jet Propulsion Laboratory. He has worked mainly with NOAA/AVHRR, METEOSAT, and Nimbus-7/SMMR data on the use of thermal infrared and passive microwaves for the determination of hydrological cycle parameters. He has been involved with several field experiments in Africa, as well as the 1987 Eos Simultaneity experiment, ISLSCP; and is a Principal Investigator for ERS-1 and MOS-1 EMDUP.

W. Timothy Liu

Dr. Liu's proposal is built upon ongoing studies in understanding climate changes as related to the hydrological and energy balances of the coupled ocean-atmosphere system. Using the new capabilities of Eos sensors, synoptic-time-scale surface moisture, momentum, and heat fluxes over the global ocean will be computed. He and his team will examine the variabilities of various terms in the atmospheric energy and water budgets and examine the interaction between different scales of atmospheric processes over oceans. The surface fluxes derived will be used to develop diagnostic models of the thermal and buoyancy forcing on ocean circulation. Eddy-resolving ocean general circulation models including thermodynamics with capabilities for

The Role Of Air-Sea Exchanges And Ocean Circulation In Climate Variability

assimilating Eos data will be developed to provide three-dimensional views of ocean circulation and heat storage.

W. Timothy Liu has been the Principal Investigator on studies concerning air-sea interaction and satellite remote sensing since he joined Jet Propulsion Laboratory in 1979. He holds M.S. and Ph.D. degrees in atmospheric sciences from the University of Washington. Dr. Liu has served on numerous science working groups for NASA, TOGA, WOCE, and JSC/CCCO and is a Principal Investigator on both the NSCAT and TOPEX Science Investigation Teams. He has participated in many multi-national field experiments.

Lyn McNutt

No one agency or country can collect and analyze the information necessary to develop and validate global change models. The CRYSYS Group proposes to delineate specific data collection sites in the Canadian North and to identify and access critical data bases as part of a global effort to monitor and evaluate the utility of remote sensing observations of cryospheric variables for observing the effects of global change. Objectives include: continuing to develop and implement the algorithms necessary to extract geophysical information related to the cryosphere; accessing information from other related data bases, especially in Canada, so that a complete record of information on cryospheric processes can be obtained; and using information from these sources in models to examine the effects of global change as manifested by cryospheric processes.

Use Of A Cryospheric System (CRYSYS) To Monitor Global Change In Canada

Lyn McNutt has been with the Canada Centre for Remote Sensing since 1984, first with the RADARSAT Project, and presently as the Ice Applications Coordinator. She received her B.A. and M.A. from the University of California, Los Angeles and a Ph.D. degree from the University of Washington. Previous research scientist positions include work at JPL on SEASAT, at NOAA/PMEL in the Marine Meteorological Group, and at the School of Oceanography, University of Washington. Ms. McNutt is also the Co- Coordinating Investigator for the Program for International Polar Ocean Research (PIPOR) and a member of the Arctic Working Group and the Remote Sensing sub-group for the Canadian IGBP.

Berrien Moore, III

The long-term goal of this research is to understand the primary biogeochemical cycles of the planet. Professor Moore's strategy is to study how element cycles function: 1) in quasi-steady state systems in the absence of human-induced perturbations, and 2) in the transient state induced by human-induced activity. The team proposed to develop global, geographically-specific, mathematical models and databases. These will describe ecosystem distribution and condition, the biological processes that determine the exchange of CO₂ and trace gases with the atmosphere, and the fluxes of carbon and nutrients to aquatic ecosystems. This suite of models will rest within an interactive information system that will integrate a geographic information system, a remote sensing system, a data base management system, a graphics package, and a modern interface shell.

Changes In Biogeochemical Cycles

Professor Moore earned his Ph.D. in mathematics from the University of Virginia in 1969. He is best known internationally for his computer modeling of the global carbon cycle. Professor Moore's specific research interests include the application of geographic information systems and remote sensing in modeling ecosystem dynamics globally. He is well published in ecosystems literature and in studies of the role of the ocean in the carbon cycle. He is involved in numerous related studies for NASA, the National Science Foundation, the Environmental Protection Agency, and the Department of Energy. Presently, Professor Moore is Director of the Institute for the Study of Earth, Oceans, and Space at the University of New Hampshire and is a Visiting Senior Scientist with the Laboratoire de Physique et Chimie Marines at the Universite de Paris.

Peter Mouginis-Mark

Dr. Mouginis-Mark's investigation objectives are to understand the physical processes associated with volcanic eruptions, to assess the rate of injection and global dispersal of sulfur dioxide into the stratosphere, and to help define and develop methods for identifying volcanic hazards as a precursor to an operational satellite eruption-monitoring system. The investigation will draw upon many of the Eos sensors and will contribute significantly to the development of a near-real-time response capability for the Eos data set with the production and distribution of algorithms suitable for automatically searching large data sets. Higher order data sets documenting each observed eruption will be the primary archival products, which will be transferred to the Central Data Handling Facility and will also be maintained

A Global Assessment Of Active Volcanism, Volcanic Hazards, and Volcanic Inputs To The Atmosphere From The Earth Observing System

locally for access by the volcanology community at large.

Academically trained in environmental sciences (Ph.D. Lancaster University, England, 1977), Dr. Mouginis-Mark has concentrated his research experience on volcanic phenomena, planetary geology, and remote sensing. He has been associated with the University of Hawaii since 1982 and presently serves as both Chairman of the Planetary Geosciences Division and as Associate Professor in the Department of Geology and Geosciences. He has been actively involved in NASA planetary and Earth-orbital missions, study groups, and working committees within his field of research and, in addition, serves as Associate Editor of *Geology* and as Editor of the Planetology Section of *EOS*.

Masato Murakami

Dr. Murakami's investigation provides a mixture of climate and meteorological modeling with an operational emphasis. He plans to focus on three components: (1) developing algorithms for the objective identification of cloud types and the quantitative measurement of precipitation by the use of space-borne observational data; (2) monitoring climatic changes of the sea surface temperature, sea level, and surface winds by the use of satellite observations. Resulting data sets can be incorporated in the ocean modeling study of seasonal and interannual variations of the Pacific and in the study of mid-latitude eddies; and (3) performing analyses of the spatial and temporal behavior of land surface boundary conditions and a numerical experiment on the impact of anomalous ground surface conditions

Investigation Of The Atmosphere/Ocean/Land System Related To Climatic Processes

on atmospheric circulation. Each project component will include observational and modeling studies, and will exchange results and data with other project components to ensure overall understanding of the Earth system.

Dr. Murakami was academically trained in geophysics and meteorology at the University of Tokyo, and earned his D.Sc. degree from that institution in 1974. Except for a two-year position at Florida State University, Dr. Murakami has been affiliated with the Meteorological Research Institute for his entire professional career. Presently he is Chief of Laboratory, the Typhoon Research Division. His research interests include tropical, monsoon, and satellite meteorology.

John Adrian Pyle

The objective of Dr. Pyle's research is to improve the understanding of the atmospheric dynamical, chemical, and radiation interactions and hence the ability to predict and detect long-term atmospheric trends in the Earth's climatic and chemical environment. He proposes a combined modeling and data analysis study by an interdisciplinary team of theoreticians to look at a variety of problems in the middle atmosphere and thermosphere. Specific topics will include the understanding of the circulation and internally-generated variability of the atmosphere; interactions between chemical, dynamical, and radiative processes; and horizontal and vertical coupling mechanisms. The study will be a two-pronged theoretical assault using--both separately and together--Eos data and sophisticated, numerical dynamical/radiative/photochemical

Chemical, Dynamical, And Radiative Interactions Through The Middle Atmosphere And Thermosphere

models of the troposphere, stratosphere, and mesosphere now being developed in the United Kingdom.

Dr. Pyle holds the D.Phil. degree in Atmospheric Physics from the University of Oxford. Since 1985 he has been a University Lecturer in Physical Chemistry at the University of Cambridge. His research interests lie in the area of modeling and data analysis; currently he serves as Principal Investigator in the U.K. Universities Global Atmospheric Modeling Project supported by NERC. He is Chairman of the U.K. Stratospheric Ozone Review Group and has served as a consultant to the European Space Agency on the future of middle atmospheric studies from space; in 1985 he was recipient of the Eurotrac award of the Remote Sensing Society.

Drew Rothrock

Dr. Rothrock proposes an interdisciplinary program in the observation and scientific utilization of surface fluxes and conditions of both the ice-covered and ice-free polar oceans. Scientific research will focus on understanding the dynamics of the upper ocean and ice cover, which control the formation of the intermediate and deep water masses of the World Ocean; on determining the atmospheric and oceanic processes which control the mass and momentum balance and extent of the sea ice cover; on understanding the feedback by which variations in ice extent affect atmospheric and oceanic circulation; and on understanding primary production in polar seas and its relation to sea ice and oceanic conditions. The program will require developing several models and algorithms, and

Polar Ocean Surface Fluxes: The Interaction Of Oceans, Ice, Atmosphere, And The Marine Biosphere

combining them into a single model of the upper ocean, ice cover (where present), and atmospheric boundary layer.

Dr. Rothrock was graduated summa cum laude from Princeton University in 1964 and earned his Ph.D. degree from the University of Cambridge in 1968. Since 1970 he has been affiliated with the University of Washington, since 1978 as Senior Research Scientist at that institution's Applied Physics Laboratory. He has concentrated his research entirely on sea ice dynamics and measurement, most specifically on the use of passive and active microwave observations. He is well represented in the current literature and currently serves as Associate Editor of the Journal of Geophysical Research.

David Schimel

Vegetation response to climate occurs through changing species composition and altered physiology. Dr. Schimel plans to couple a simple ecosystem model (SEM) with spectral data from several Eos sensors to monitor changing patterns of physiology and ecosystem function in response to climate variability and directional change. The investigation's primary objective will be to develop and evaluate a simulation model of ecosystem controls over the water, energy, and carbon cycles within global grasslands. He also will develop analytical techniques to separate the remotely-sensed grassland canopy signal from "background" signal; and also plans to explore ecological scaling through evaluation of plot-level parameters at regional extrapolation in parallel

Using Multi-sensor Data To Model Factors Limiting Carbon Balance In Global Grasslands

with analysis of leaf, canopy, and regional-scale spectral measurements.

David Schimel received his Ph.D. in 1982 and has been on the Senior Staff of the Natural Resources Ecology Laboratory since 1983; his research addresses basic questions in biogeochemical cycling and the development of techniques for extrapolating rates of processes to landscape and regional scales. He is currently an NRC Senior Fellow at NASA/Ames Research Center. Dr. Schimel is involved with program of the International Geosphere-Biosphere program in the areas of trace gas exchange and global ecosystem modeling.

Mark R. Schoeberl

Dr. Schoeberl proposes a two-component effort to characterize both the short- and long-term stratospheric changes which have occurred and will occur over the period beginning with Nimbus-7 observations in late 1978, continuing with UARS, and on through the Eos observing period. His team will link and extend ongoing GSFC efforts by generating high-precision, validated climatological data sets for ozone, temperature, and trace gases. These data sets will be used to investigate the physics and chemistry of the stratosphere. In particular, Dr. Schoeberl is interested in being able to separate natural and anthropogenic changes in the stratosphere in order to better assess the exact magnitude of anthropogenic changes and to understand the natural

Investigate The Chemical And Dynamical Changes In The Stratosphere Up To And During The Eos Observing Period

chemical/dynamical/radiative interaction and feedback processes within the stratosphere.

Mark Schoeberl received his M.S. and Ph.D. degrees from the University of Illinois; he has 13 years research experience in atmospheric dynamics, stratospheric physics, and numerical modeling. Since 1983 Dr. Schoeberl has been affiliated with the NASA/Goddard Space Flight Center and is presently with the Atmospheric Chemistry and Dynamics Branch. Within his field of research, Dr. Schoeberl has chaired conferences and committees or served in an editorial capacity on numerous occasions. He is a recipient of the NRL Publication Award and a NASA Technical Achievement Award.

Piers John Sellers

Dr. Sellers' research will focus on the interaction between the land surface and the atmosphere, stressing the biospheric exchanges of energy, water, and carbon. The scope of the investigation will be global and will combine an extended time series of remote sensing data with interpretive models and a realistic combined model of the terrestrial biosphere and the global atmosphere. Related work will focus on terrestrial ecosystem processes, particularly the use of models driven by satellite data. In carrying out this research, his team hopes to achieve broader goals as well: In addition to improving the understanding of the critical components of the Earth system, the research will yield new and improved products of derived surface and atmospheric parameters, and will be directly useful in developing methodologies

Biosphere-Atmosphere Interactions

to extract maximum benefit from the Earth Observing System.

Piers Sellers is an honors graduate of Edinburgh University and received his Ph.D. degree from Leeds University in 1981; he has around 10 years of experience in the fields of natural and environmental resources, computer systems analysis, computer simulation, atmosphere/biosphere interactions and remote sensing, and meteorology. Dr. Sellers is presently a Faculty Research Scientist in the Department of Meteorology at the University of Maryland. He has been extensively involved with the International Satellite Land Surface Climatology Project (ISLSCP), serving as Staff Scientist for the First ISLSCP Field Experiment.

Meric A. Srokosz

Much effort is presently being expended on determining the long-term and large-scale means and trends in the structure of the oceans. Stressing the importance of understanding variability as well, Dr. Srokosz proposes to build on on-going and planned field work to examine the spatial and temporal variability of the eastern North Atlantic and Southern Oceans. MAHLOVS will make significant use of the microwave, visible, and infrared sensors to investigate the variability of the atmospheric forcing of the oceans, the consequent effect on the oceanic response, and the resulting effect on the oceans' biological productivity. These data will be combined in a synergistic manner and assimilated into an ocean model; the result will be statistical descriptions of the temporal and spatial variability of the atmosphere-ocean-biology system and their

Middle And High Latitudes Oceanic Variability Study (MAHLOVS)

interrelationships on space scales ranging from 1 to 1,000 km and time scales of days to years.

Meric A. Srokosz has 10 years experience in the fields of applied mathematics, remote sensing of oceans, and radar altimetry. He holds both undergraduate and doctoral degrees in mathematics from Bristol University. Currently he serves on the NERC Remote Sensing Applications Development Unit of the British National Space Center where he is responsible for coordination of United Kingdom activities in remote sensing of the oceans, and development of applications and research on remote sensing of the oceans. Dr. Srokosz is a Principal Investigator for the ERS-1 Mission and Co-Investigator on the TOPEX/Poseidon and SIR-C Missions.

Byron Tapley

The objective of the investigation is to develop appropriate system models and to use Eos data from multiple sensors in combination with other satellite and in situ data, to refine understanding of the relationship between the atmosphere, oceans, and solid Earth, and the exchange of energy and angular momentum between these components of the Earth's dynamic system. Specific studies include understanding the contribution of air, water, and atmospheric motion to Earth rotation variations and related angular momentum exchange; and establishing a Conventional Terrestrial Reference System for over 100 station locations for monitoring change, including tectonic and global sea level change over multiple decades.

Earth System Dynamics: The Determination And Interpretation Of The Global Angular Momentum Budget Using The Earth Observing System

Dr. Tapley earned undergraduate and doctoral degrees at the University of Texas at Austin, and has over 30 years experience in aerospace engineering. He began teaching at his alma mater in 1958; since 1984 he has held the Clare Cockrell Williams Centennial Chair in the Department of Aerospace Engineering and Engineering Mechanics. In addition to academic activities, Dr. Tapley is Director of the Center for Space Research at that institution. Beyond the topic of his planned Eos interdisciplinary investigation, his research interests focus on the application of non-linear parameter estimation methods to determination of crustal motion, Earth rotation, Earth's geopotential and ocean circulation.

Bruce A. Wielicki

Dr. Wielicki's investigation will provide the Earth Observing System with a consistent data base of accurately known fields of radiation and of cloud properties. The radiation will be provided as fluxes at the top of the Earth's atmosphere, at the Earth's surface, and as flux divergences within the atmosphere. Cloud properties will be provided as measured areal coverage, cloud altitude, shortwave and longwave optical depths, cloud particle size, and condensed-water density. This research will allow the determination of the interaction of clouds with the Earth's climate and further understanding regarding the climatic effects of man's changes to the Earth's surface. The data products will also be fundamental for determining trends in clear sky and cloudy fluxes, as well as experiments in long-range weather forecasting and climate prediction.

An Interdisciplinary Investigation Of Clouds And Earth's Radiant Energy System: Analysis (CERES-A)

Dr. Wielicki was awarded his Ph.D. degree in physical oceanography from the Scripps Institution of Oceanography in 1980. He has focused primarily on atmospheric research concerning cloud properties, cloud retrieval, and the Earth radiation budget. Following a three-year assignment with NCAR, Dr. Wielicki joined NASA's Langley Research Center in 1980 as Research Scientist. There, he served as principal investigator on the Landsat Thematic Mapper science team; on-going investigations include work as Co-investigator on the Earth Radiation Budget Experiment (ERBE) and a role as Project Scientist and Principal Investigator for the First ISCCP Regional Experiment (FIRE).

