

N91-23029

Direction Discriminating Hearing Aid System

M. Jhabvala
NASA/GSFC, Greenbelt, MD
H.C. Lin
University of Maryland, College Park, MD
G. Ward
DTI, Engineering, Oxon Hill, MD

Abstract

A visual display system has been developed for people with substantial hearing loss in either one or both ears. The system consists of three discreet units: an eyeglass assembly for the visual display of the origin or direction of sounds; a stationary general purpose noise alarm; and a noise seeker wand.

Introduction

Individuals who suffer a severe hearing loss in one ear have great difficulty discerning the direction from which sounds originate. Situations exist where individuals must be made immediately aware of the origin of the sound, especially sound intended as a warning. Typical examples include: street traffic, loading dock horns, sirens and a variety of other less common audibles but still of significant warning authority. Other situations exist where hearing impaired individuals need to be cognizant of an audible signal. A stationary alarm was developed to assist individuals in situations such as a knocking on a door, a baby crying in another room or even a faucet left running. In conjunction with the stationary alarm a noise seeker was also developed to assist individuals in locating the origin of the sound if not readily apparent. The Solid State Device Development Branch (Code 724) supported by the GSFC Office of Commercial Programs embarked on a program to develop systems which would address these needs. The University of Maryland's Electrical Engineering Department provided design and fabrication expertise and after successful breadboard tests Design Three Incorporated developed a commercial prototype under NASA contract.

Method

Eyeglass Assembly

The most complicated of the three units is the eyeglass assembly. Aside from performing the necessary decision making and display functions the electronics had to fit compactly into an eyeglass frame. The components in the eyeglass include a custom developed CMOS integrated circuit, two miniature batteries, two miniature sensing microphones, capacitors, resistors, potentiometers and light emitting diodes (LEDs).

The electrical organization of the system is shown in Fig.1. An audio signal is detected by each of the two microphones positioned in the eyeglass stems. Keeping in mind that the direction from which the sound originated is the desired parameter the signal generated by the microphone more closely facing the audio source will be the stronger of the two. Both microphone signals are amplified and then rectified. This rectified d.c. signal is then processed through an 3-bit analog to digital (A/D) converter. The two digital signals are encoded to binary numbers identifying the signal in one of the three volume level categories. The signals are compared and only the stronger signal is permitted to travel forward. There are seven LEDs, three on the top of each eyeglass lens and one at the bottom of one of the lenses. A red, green or yellow LED on the lens will illuminate based on the loudness of the sound received on that side of the individual. Based on the binary encoding, logic circuitry will determine which of the three LED's should be illuminated, red (loud), green (medium) or yellow (soft). In the instance where the sound originated directly in front of or behind the individual an equal LED (clear) is illuminated indicating a strong enough sound but either directly in front of or directly behind the individual.

In order to compact all the electronics into a minimal area a custom integrated circuit was designed and manufactured. All the electronics including the A/D, encoder, comparator, logic and LED drivers were condensed to an area 0.18 inches by 0.26 inches. The chip is powered by two lithium batteries ($\pm 3v$). Fig. 2 is a photograph of the integrated circuit. A schematic layout of the eyeglass assembly is shown in Fig. 3.

Stationary Alarm

The stationary alarm is a free standing portable unit with a high intensity xenon flash tube as the light indicator. It can be placed near a door, for example, to visually alert an individual that there is a knock or door bell ring occurring. An external control provides signal adjustment to control the xenon light threshold flash level and the unit as currently designed operates from a 110 volt supply. The stationary alarm unit is shown in Fig. 4.

Noise Seeker Unit

The third component of this ensemble is the noise seeker unit. This unit has LED bar graph displays as the indicator and is powered by rechargeable batteries. This unit is intended to be used in conjunction with the stationary alarm to assist in locating the origin of a noise signal that triggered the alarm. The noise seeker plugs into the stationary alarm where it is recharged when the stationary alarm unit is powered by 110 AC. This feature also keeps the noise seeker unit in close proximity to the alarm. The seeker uses highly uni-directional microphones. When the unit is aimed directly at the noise source the bar graph LED's will illuminate. As the wand is rotated away from the noise source fewer and fewer LED's will illuminate thus giving the bearer a good indication in which direction to proceed. A diagram of the noise seeker unit is shown in Fig. 5.

Conclusion

In an effort to transfer some of the microelectronics and miniaturization techniques used at the NASA/Goddard Space Flight Center to the public sector a system has been conceived, designed, developed and now commercially prototyped to assist hearing impaired individuals. The work, sponsored by Mr. Don Friedman of the Office of Commercial Program, was a collaborative effort involving numerous graduate students at the University of Maryland, other government agencies, private institutions and industry. It is hoped that NASA and the governments role will have been successfully completed and that these units will ultimately find their way to those individuals who need them.

References

Jhabvala, M.; Lin, H.C.; Wang, Z.S; Chen, T.; and Zong, Q.:
Direction Discriminating Hearing Aid System
RESNA 12th Annual Conference; New Orleans, 1989.

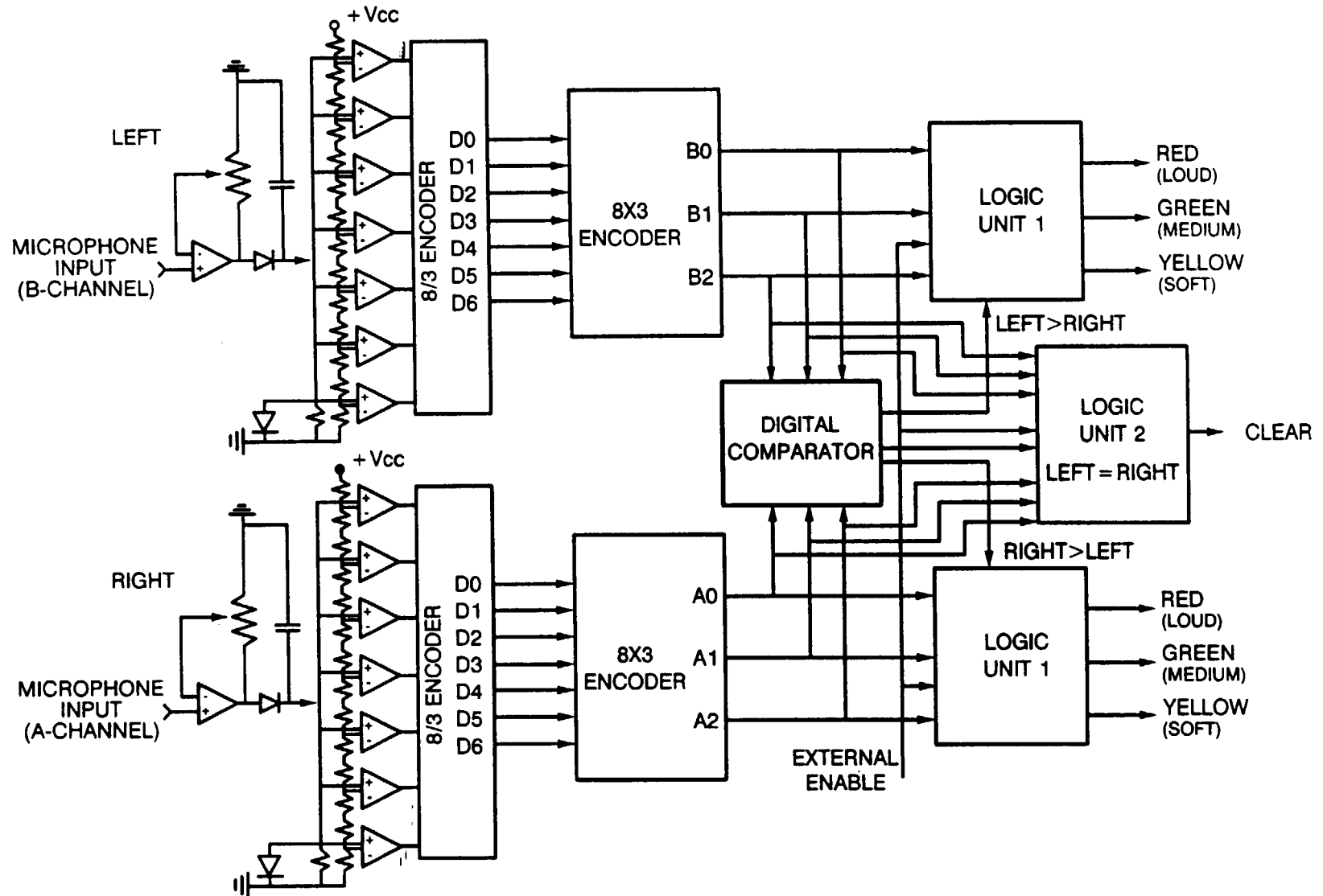

FIGURE 1 BLOCK DIAGRAM OF THE SYSTEM ELECTRONICS FOR THE EYEGASS ASSEMBLY

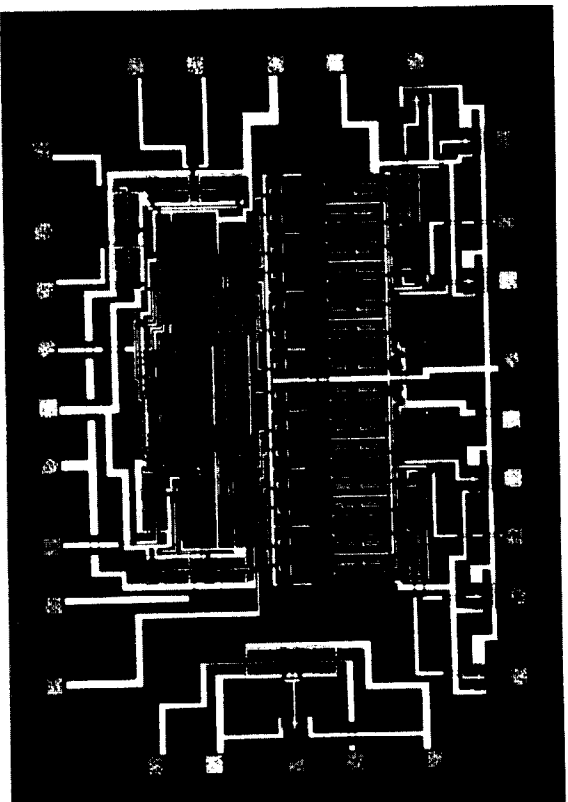
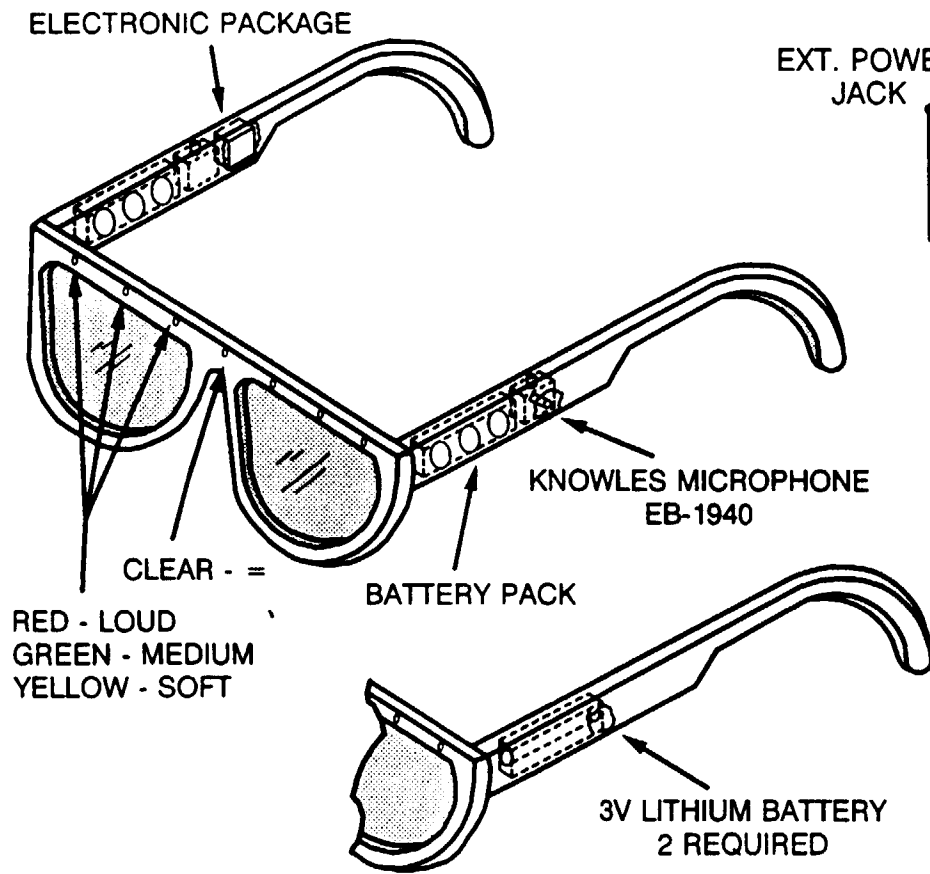

FIGURE 2 PHOTOMICROGRAPH OF CMOS INTEGRATED CIRCUIT

EYE GLASS ASSEMBLY



BLOCK DIAGRAM

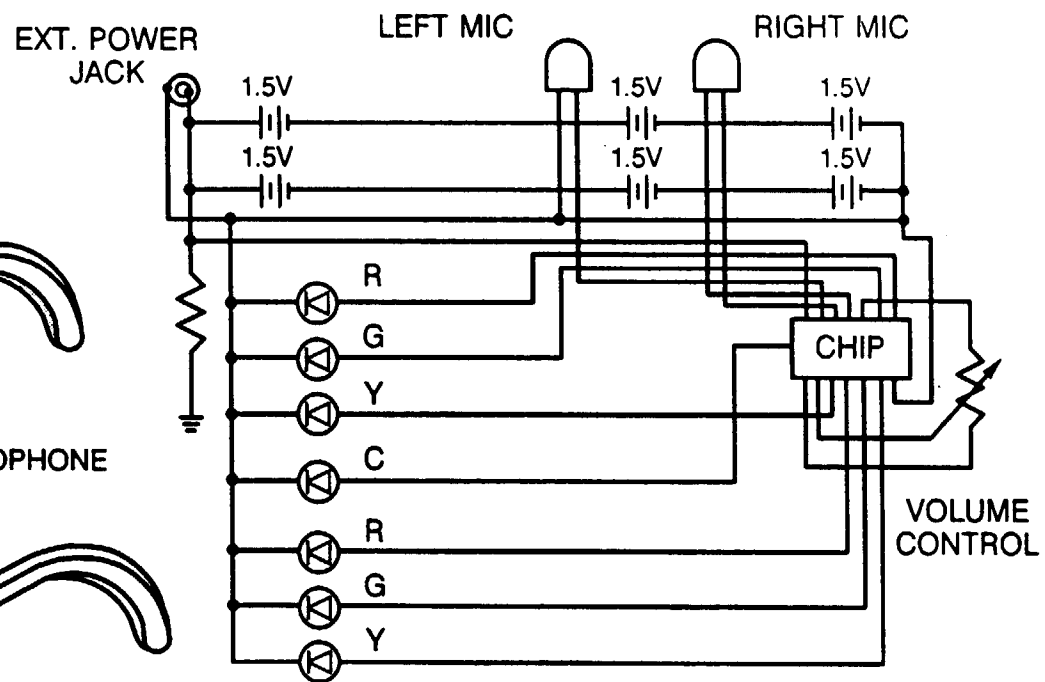

FIGURE 3 EYEGLOSS ASSEMBLY AND LED DISPLAY DETAIL

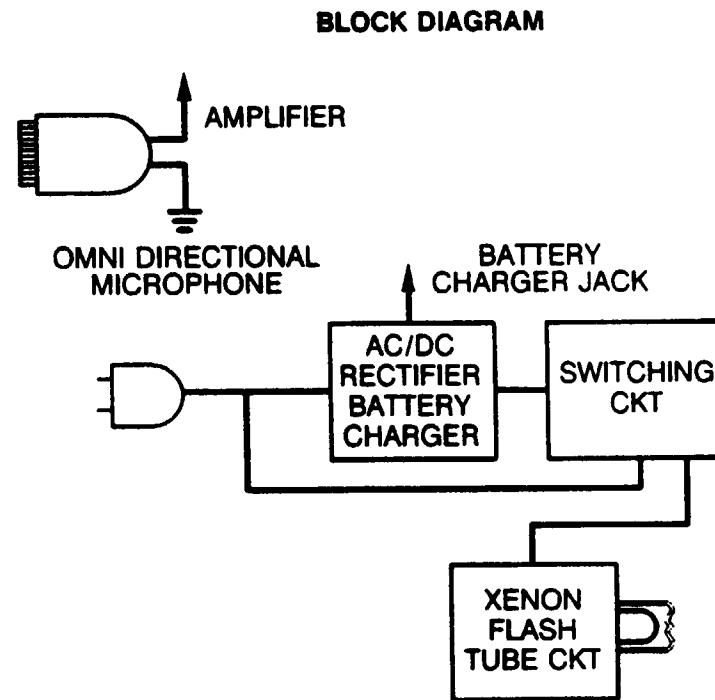
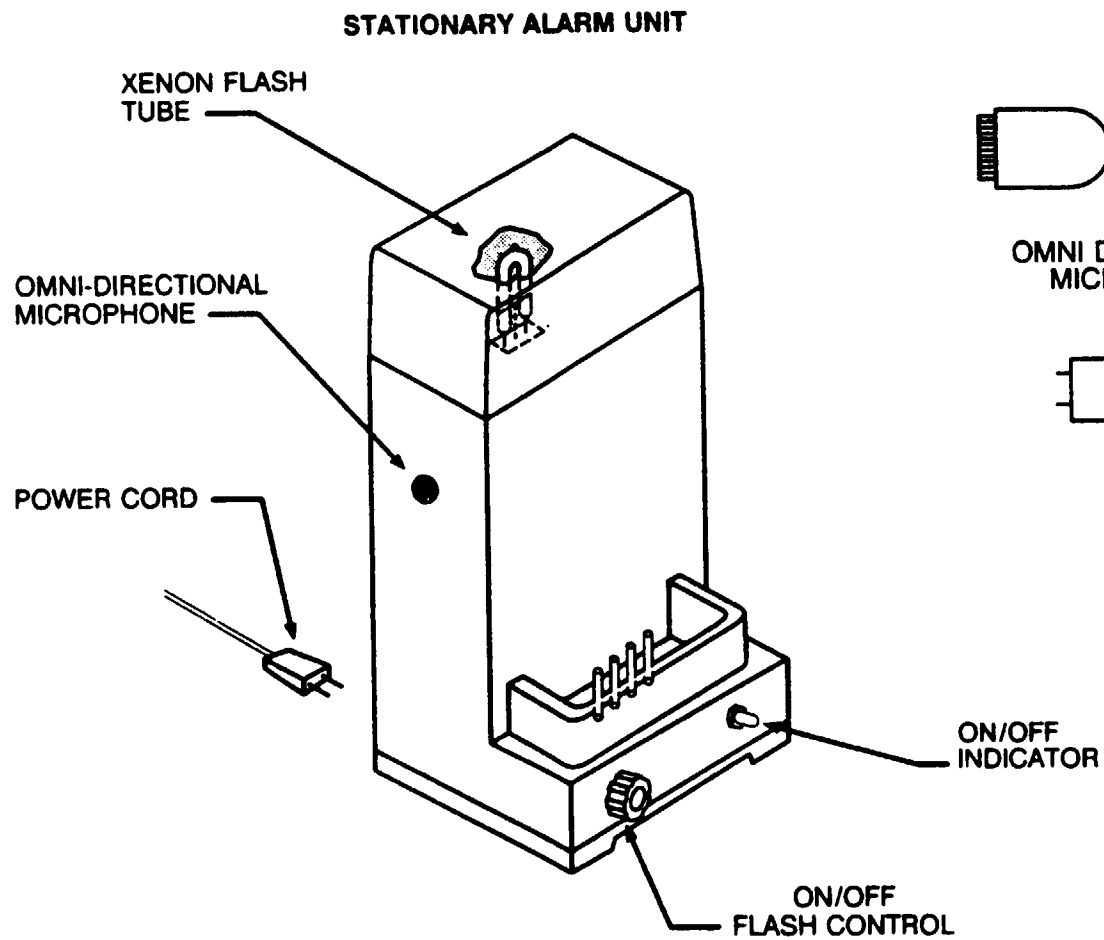

FIGURE 4 STATIONARY ALARM UNIT

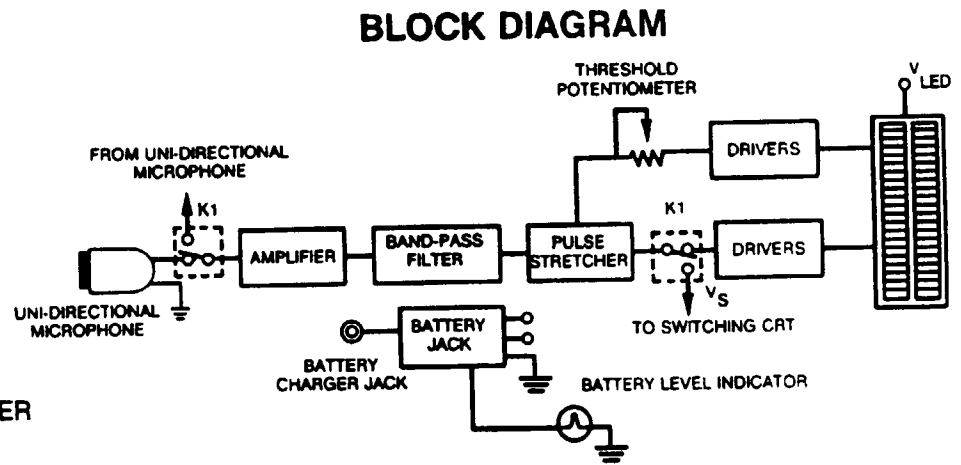
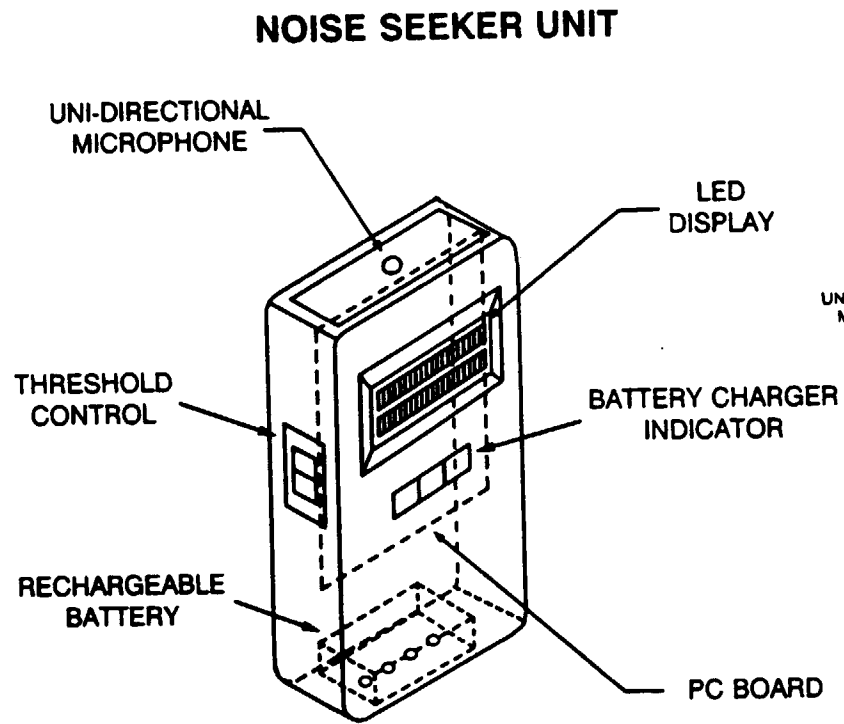

FIGURE 5 NOISE SEEKER UNIT AND SYSTEM BLOCK DIAGRAM