

N91-23052

LIGHTWEIGHT, FIRE-RETARDANT, CRASHWORTHY AIRCRAFT SEAT CUSHIONING

Leonard A. Haslim
Paul T. McDonough

Civil Technology Office
NASA Ames Research Center

The primary goal of NASA Ames Research Center's Civil Technology Office (CTO) is to provide American industry with hi-technology products. The research and development done at Ames is transferred smoothly and expediently so as to keep America on the cutting edge in a competitive global marketplace. The majority of the ideas and products developed by the CTO are aerospace-related, but often spin-offs from the technology reached non-aerospace markets. One such technology is the light-weight, fire retardant, crashworthy aircraft seat cushioning which promises to revolutionize the safety and comfort of both aerospace and non-aerospace seating.

Presently, most aircraft, automobile, train, bus, hotel and hospital seating is composed of polyurethane foam. Although it is inexpensive and comfortable, the foam is lethal when ignited. It burns quickly, producing a dense white smoke and emits highly lethal hydrogen cyanide gas, if not immediately ventilated, will cause death. In 1977 in the Canary Islands, two Boeing 747's collided on the ground. Most of the 583 passengers died from smoke inhalation and burns. In many crash investigations, it was found that the smoke, not the fire, was the lethal factor. In the hopes of avoiding such catastrophe, the Civil Technology Office began experimenting with new materials and seat designs which would alleviate the use of the urethane foam.

The Safety Seat Cushioning (SSC) was designed for both safety and comfort. Composed of advanced fabric reinforced composites, it is lightweight, fire-retardant and crashworthy. The seat design consists of central elliptical tubular spring supports made of fire-resistant and fatigue-durable composites surrounded by a fire-blocking sheath. The cushioning is made crashworthy by incorporating energy-absorbing, visco-elastic layers between the nested, elliptical-hoop springs; a highly desirable feature for helicopters. The design is intended to provide comfortable seating that meets aircraft-loading requirements without using the conventional polyurethane materials.

Aside from its fire-resistant and energy-absorbing characteristics, the SSC is lightweight, economical, simple to fabricate, structurally strong and easily maintained. Although its initial intent was for aircraft and helicopter seating, the SSC has also become popular with automotive and furniture manufacturers.

Several key features of the SSC have attracted the automotive industry. For the same safety concerns as with aircraft seats, automobile accidents would be much less hazardous without the combustible and toxic urethane foam seating. Also, the durability and maintainability of the hoops will provide long-lasting comfort to the occupants. Another interesting feature is that heating ducts can be inserted into the SSC tube assembly. Because of its energy-absorbing characteristic, a replacement for a five mile an hour bumper has also been proposed.

The SSC can be applied to most mass transit systems, particularly busses and trains. Train and bus passengers will benefit from the SSC in both safety and comfort. In the 1989 Kentucky school bus tragedy, three adults and 24 children were killed. All of the victims died of smoke inhalation, not from injuries sustained in the crash. Once again, polyurethane foam's toxic and flammable properties inhibited escape and rescue.

The Civil Technology Office has also been in contact with navy ship manufacturers who want to incorporate the SSC into ship design. Not only for its fire-retardant properties, but its energy-absorbing

characteristic will help reduce personal injury and damage to ship computer hardware caused by explosive mines and near misses. In such a scenario, the ship is rocked with a violent jolt which can cause spinal injuries and destroy sensitive electronic systems.

Other non-aerospace applications include home, hotel and hospital furniture and bedding. Furniture manufacturers are also interested in the SSC's durability and comfort aspects, as well as its fire-resistance. The incidence of injury in high rise hotel fires would be greatly reduced if the polyurethane foam bedding and furniture were eliminated. Escape, rescue and eventual extinguishing would all be enhanced. Hospital bedding could be made more comfortable for patients with the use of heating ducts applied in a therapeutic manner.

The applications of the SSC are varied and numerous. The manufacture and cost of the seat spring assembly is both simple and economical. Patented by NASA and easily accessible to industry through the Technology Utilization Office, the Civil Technology Office's SSC is a fine example of NASA technology developed with safety, comfort and well-being in mind.

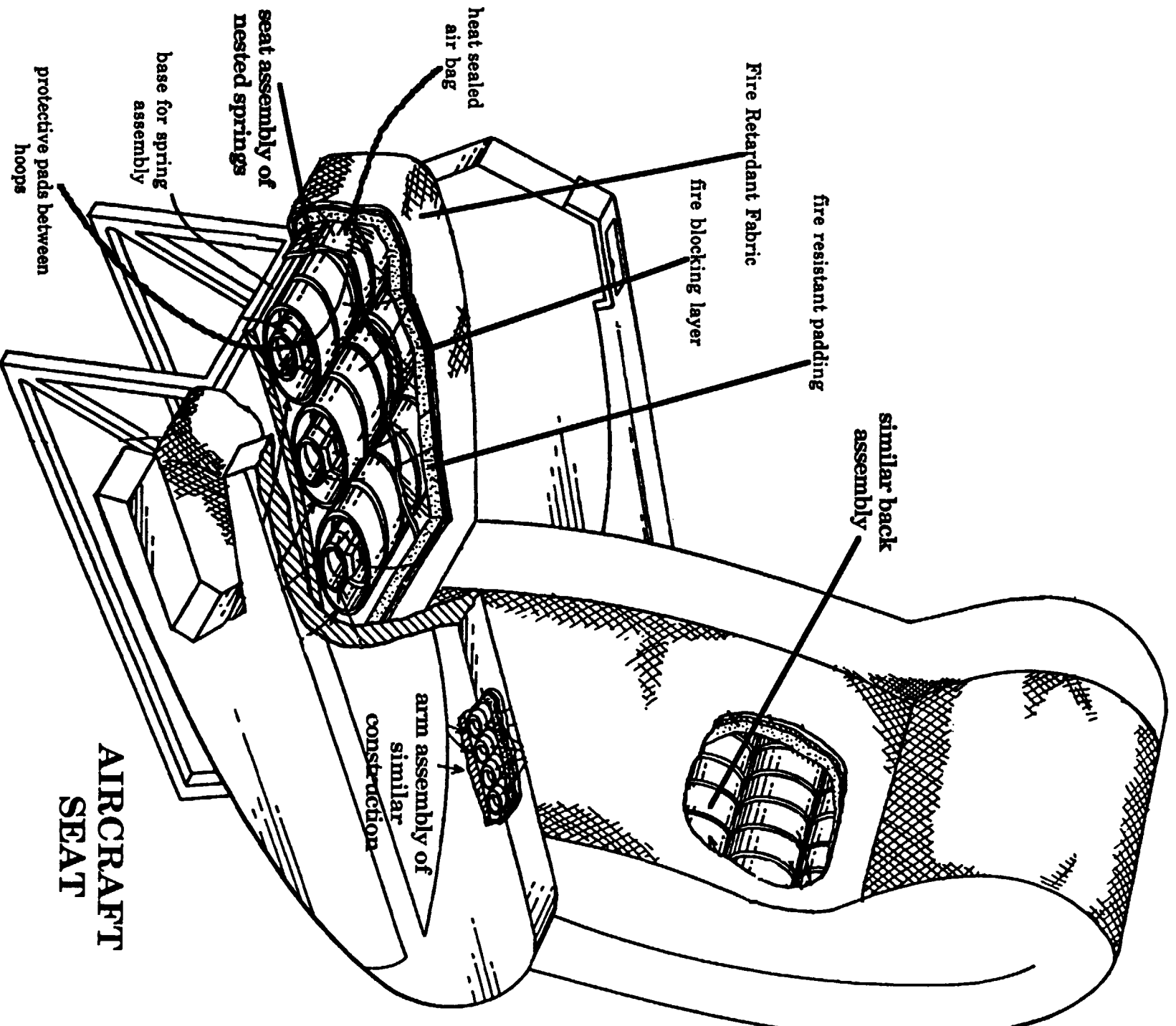

AIRCRAFT SEAT

NESTED SPRINGS USED WITH INNER ELASTOMERIC LINING

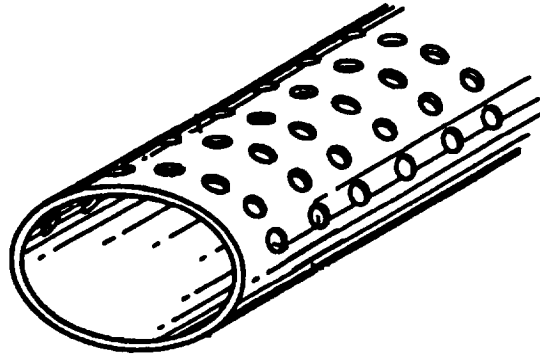

CONSTRUCTION OF INNER NESTED TUBE

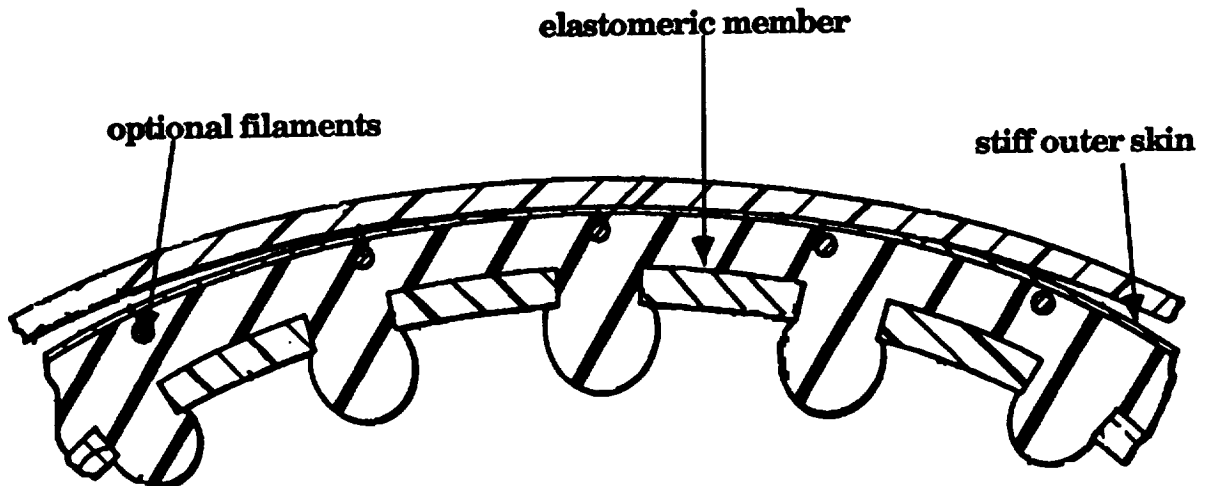
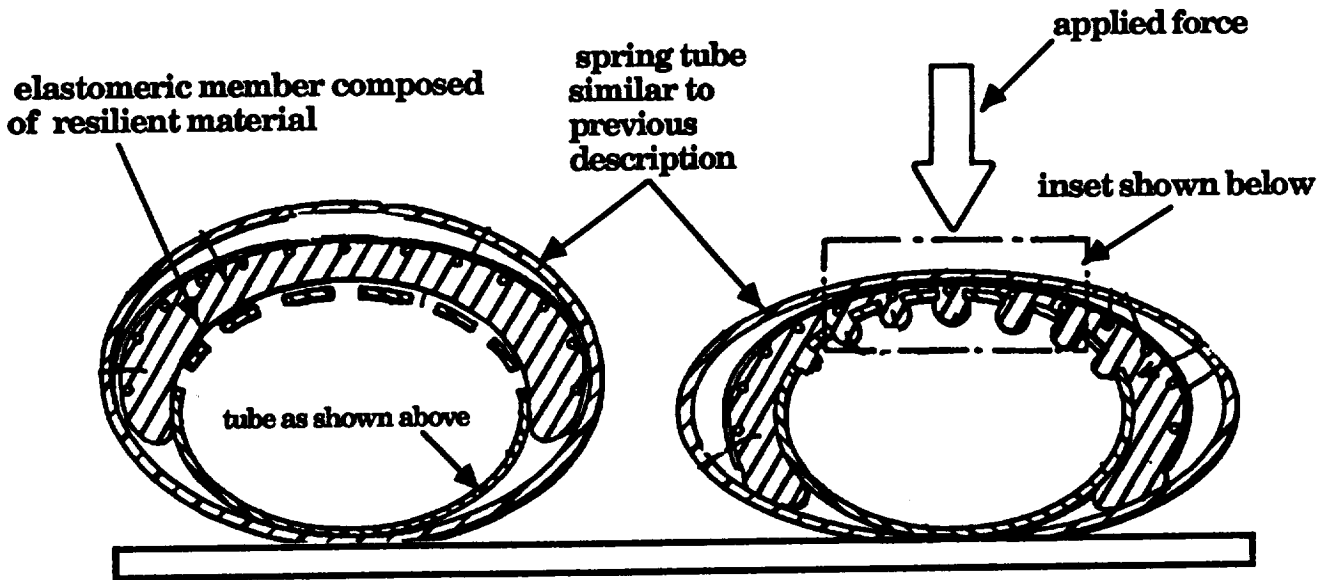

Applied force is damped as elastomer flows through inner nested tube

