

N91-24060

MONITORING AND CONTROL TECHNOLOGIES FOR BIOREGENERATIVE LIFE SUPPORT SYSTEMS/CELSS

William M. Knott, Ph.D.
and
John C. Sager, Ph.D.

ABSTRACT

The development of a Controlled Ecological Life Support System (CELSS) will require NASA to develop innovative monitoring and control technologies to operate the different components of the system. Primary effort over the past three to four years has been directed toward the development of technologies to operate a Biomass Production Module. Computer hardware and software required to operate and collect and summarize environmental data for a large plant growth chamber facility has been developed and refined. Sensors and controls required to collect information on such physical parameters as relative humidity, temperature, irradiance, pressure, and gases in the atmosphere; and PH, dissolved oxygen, fluid flow rates, and electrical conductivity in the nutrient solutions are being developed and tested. Technologies required to produce high artificial irradiance for plant growth and those required to collect and transport natural light into a plant growth chamber are also being evaluated. Significant effort has been directed towards the development and testing of a membrane nutrient delivery system potentially useful in growing plants in the microgravity of space. Robotic and plant imaging systems required to manipulate, seed, and harvest crops, and to determine plant health prior to stress impacting plant productivity are also being researched. Tissue culture technologies are being developed for use in management and propagation of crop plants. Though previous efforts have focused on development of technologies required to operate a Biomass Production Module for a CELSS, current efforts are expanding to include technologies required to operate modules such as food preparation, biomass processing, and resource (waste) recovery which are integral parts of a CELSS.

INTRODUCTION

The Controlled Ecological Life Support System (CELSS) is developing the science database required to build and operate an bioregenerative life support system in space. Such a system has been identified to be a requirement to develop a permanent presence in space (Paine, 1986 /1/; Robbins, 1988 /2/). There is insufficient data at this time to predict when such a system will be economically feasible for a specific mission scenario or what components will be included in a functioning CELSS. However, if humans are going to be anything other than visitors in the space environment, such a system must ultimately be developed. The current CELSS program is a research and development effort which should grow steadily into a major hardware development program after a sufficient science and technology database exists.

The CELSS Breadboard Project (Koller, 1986 /3/; Prince and Knott, 1989 /4/) being conducted at the Kennedy Space Center has as its major goal the development and operation of an initial CELSS at a one person scale to demonstrate feasibility for the development of such a system. This project was initiated in late 1986 with the first research data being collected on biomass production in 1988. The current schedule is for the initial Breadboard CELSS configuration to be completed in 1993 and tested by the end of 1994. The components or modules being developed for inclusion in the initial CELSS Breadboard are as depicted in Figure 1. There are four major modules, Biomass Production, Biomass Processing, Food Preparation, and Resource Recovery. For either one of these modules to be operated successfully will require a major enhancement of monitoring and control technologies. This presentation will describe the CELSS Breadboard Project, discuss current technologies being developed, and identify requirements for new technologies necessary for monitoring and controlling the system.

THE BREADBOARD PROJECT

The current Breadboard Project is centered around a large atmospherically sealed plant growth facility, the Biomass Production Chamber (BPC) (Figure 2), which was constructed to measure energy use and mass

flow through a crop community over its entire life cycle. A series of experiments are being conducted in the BPC to evaluate crop species in this closed environmentally controlled facility (Wheeler and Sager, 1990 /5/; Wheeler et. al, 1990 /6/). During these trials, emphasis is being placed on the effect of different environmental conditions on plant growth, CO₂ exchange, water use, and mineral uptake. Microbiological sampling and analyzes are conducted during each plant growth study in order to determine the functional relationships between the microorganisms and the plants, especially in the rhizosphere. Total biomass production is measured for each crop as the plants are harvested from the chamber. Other modules of a CELSS which are required to convert this biomass into food and to recycle all materials back to the plants are being developed in laboratories adjacent to the BPC. The edible biomass is transferred to the processing laboratory (kitchen) so that meals can be prepared and tested. Various processing procedures are being evaluated in order to determine amount of time required to accomplish the task, to identify equipment requirements, and to evaluate the meals for nutritional value and palatability. The inedible biomass is transferred to the resource recovery lab so that various subcomponents that may convert this material into an edible substance can be evaluated. These subcomponents include aquaculture, enzyme degradation of cellulose into sugars, and fungal production processes. Material left over from either the food preparation or biomass processing activities must be converted to CO₂, water, and minerals for return to the Biomass Production Chamber. Resource recovery subcomponents that are currently being tested to accomplish this include a leachate reactor and aerobic microbiological reactors.

Tests of each resource recovery subcomponent is designed to obtain mass flow data through each component in the context of a total integrated system. Emphasis is being placed on the cycling of carbon, hydrogen, oxygen and nitrogen along with selected major minerals. A related activity will evaluate total pyrolysis of the edible biomass to determine the products generated and the energy used. The measurement of water cycled through each subcomponent of the Breadboard is of major interest during all project activities. The water loop on the BPC is currently being closed and hygiene water being used by the human along with his liquid waste will be measured and recycled through the appropriate subcomponents.

The initial total Breadboard system is scheduled to be complete by 1993. Extended testing of this system will occur during 1993 and 1994. A total reconstruction of a CELSS, the Integration Test Facility, at a three to four person scale is scheduled for 1995.

ADVANCED TECHNOLOGY DEVELOPMENT

One of the major problems encountered to date in the construction and operation of the Breadboard CELSS is the reliability of the physical systems required to maintain the biological organisms. The biology has been very reliable and predictable but the monitoring and controlled technologies required to maintain a proper environment for the organisms has been unreliable. Several objectives need to be met as we attempt to improve the technologies required for the successful deployment and operation of a CELSS in space. Monitoring and control technologies must be developed to minimize energy use and limit manpower requirements. The elements must be miniature in size, light in mass, and durable. Their measuring capabilities must be real time, on-line, and adequately sensitive for proper system controls. Their operational reliability must be over an extremely long time duration and must require minimal maintenance. Finally, elements of a CELSS which will be deployed in free space must have the capability of operating in a microgravity environment.

Several advanced technologies required to operate the Biomass Production Module of a CELSS have been identified. Fiber optic sensors for on-line monitoring and control for selected parameters in the BPC are being developed and tested. Parameters to be measured by the sensors include atmospheric ethylene, trace organic contaminants, pH, moisture levels, microbial organisms, and specific ions in nutrient delivery solutions. These sensors use primary and secondary absorbance and liquid atomic emission technologies as their primary measuring processes. Most of the sensors currently available for monitoring these and other parameters in the Biomass Production Chamber are not sensitive enough or when on-line require excessive maintenance to keep them operative. Development of computer software will be required in order to establish expert control of the atmosphere in the BPC using the outputs from the array of sensors. We have developed some chamber

control software along with new data display capability for the BPC during the past two years. Technologies for the production, transportation, and distribution of irradiance for plant growth is another primary area of interest to the CELSS program. Current research in this area has concentrated on a light pipe material and fiber optics for transportation and distribution of the light energy. Of major importance in this technology area is the increased efficiency of bulbs and the maximum delivery of photons to the plant surface.

At least one project is evaluating noninvasive remote sensing systems that may be useful in detecting water stress and/or nutrient deficiency in plants. A technology that will detect plant stress prior to it reaching a level to cause a decrease in productivity is vital to the successful development of a CELSS. Robots with vision imaging capabilities will be required to locate sensors and conduct plant manipulations such as seeding and harvesting. A seeding robot for wheat has been developed and tested. The development of robotic capabilities that will significantly reduce the time required to operate the Plant Production Module is important. Finally, if the CELSS is to operate in a microgravity environment then a major requirement is to develop a system to deliver water and nutrients to the roots of plants under these conditions (Wright, et. al. 1988 /7/). We have developed and tested a membrane nutrient delivery system (Figure 3) as a potential technology to accomplish this task (Dreschel and Sager, 1989 /8/). Other projected areas requiring technology development in order to develop a successful Biomass Production Module for a CELSS include genetic plant engineering, management of tissue culture systems, trace contaminant removal from air and water, and water collection devices.

Many of the technologies discussed previously for the Biomass Production Module are also required for the Food Preparation, Biomass Processing, and Resource Recovery Modules. Advance sensor technology and expert computer control are needed to operate bioreactors that are vital to these modules. The requirements for these sensors and computer software are identical to or only slightly modified from those discussed for the Biomass Production Module. New equipment to thrash, mill, and grind edible biomass and to process the same into food needs to be developed. This equipment must be small, easy to operate, and extremely efficient so that little, if any, wastage occurs. The aquaculture system will require some advance technologies that have not been previously discussed. Sensors and controls for the nitrogen wastes produced by the fish must be developed. Development of a food for the fish using only inedible plant material is a major challenge. Technologies to reduce the amount of water to support the fish and video systems to monitor the health of the fish are a few other capabilities which require research. There is no doubt as these processing and resource recovery modules become more a part of the Breadboard Project, additional advance technologies required to operate these modules will be identified.

SUMMARY

The CELSS Breadboard Project is proceeding on schedule and a demonstration of feasibility at a one person scale should be accomplished in the next 3-4 years. The Biomass Production Module is complete and producing data on plant growth and development, water cycling, and carbon dioxide and oxygen exchange. During the past 2-3 months, efforts have been initiated to develop the Food Preparation, Biomass Processing, and Resource Recovery Modules that will complete the initial CELSS Breadboard. In order for a CELSS to be deployable in space to meet the life support requirements of humans, significant advancement in selected technologies is required. A few technologies are currently being researched such as fiber optic sensors, noninvasive remote plant stress sensors, expert computer controls, and microgravity compatible nutrient delivery systems. Improved sensor sensitivity and reliability, efficient irradiance production and delivery systems, and expert computer controls must be developed in order to control the physical systems required to maintain the biology. Technologies to monitor biological stress, to accomplish genetic engineering, and to provide tissue culture maintenance must be completed prior to the development of an operational CELSS. The development of advanced technologies are primarily aimed at reduction in energy use, limiting manpower requirements, miniaturization of subcomponents, improved operation reliability, on-line monitoring capabilities, and functionality in microgravity. In order for human beings to develop a truly permanent presence in space, a CELSS must be developed and a significant advancement in technologies is required in order to make such a life support system possible.

LITERATURE

1. Pioneering the Space Frontier. National Commission on Space (The Paine Commission), New York, Bantam Books, 1986.
2. Exploring the Universe: A Strategy for Space Life Sciences. (The "Robbins" Report), Life Sciences Strategic Planning Study Committee, NASA Advisory Council, Washington, D.C.
3. Koller, A. M.. CELSS Breadboard Facility Project Plan. Biomedical Operations and Research Office. National Aeronautics & Space Administration, Kennedy Space Center. March 1986.
4. Prince, R. P. and Knott, W. M.: CELSS Breadboard Project at the Kennedy Space Center. In: D. W. Ming and D. L. Henninger (eds.), Lunar Base Agriculture; Soils for Plant Growth. Amer. Soc. Agron., Madison, WI USA. 1989.
5. Wheeler, R. M. and Sager, J. C.: Carbon Dioxide and water exchange rates by a wheat crop in NASA's Biomass Production Chamber results from an 86-day study (January to April 1989). NASA Technical Memorandum. TM 102788. January 1990.
6. Wheeler, R. M., Mackowaik, C. L., Dreschel, T. W., Sager, J. C., Prince, R. P., Knott, W. M., Hinkle, C. R. and Strayer, R. F.: System development and early biological tests in NASA's Biomass Production Chamber. National Aeronautics & Space Administration. Technical Memorandum. TM 103494. March 1990.
7. Wright, B. D., Bausch, W. C. and Knott, W. M.: A Hydroponic system for microgravity plant experiments. Trans of the ASAE. 31(2). 440-446. 1988.
8. Dreschel, T. W. and Sager, J. C.: Control of water and nutrients using porous tube: A method for growing plants in space. HortScience 24(6): 944-947. 1989.

CELSS BREADBOARD CONCEPT

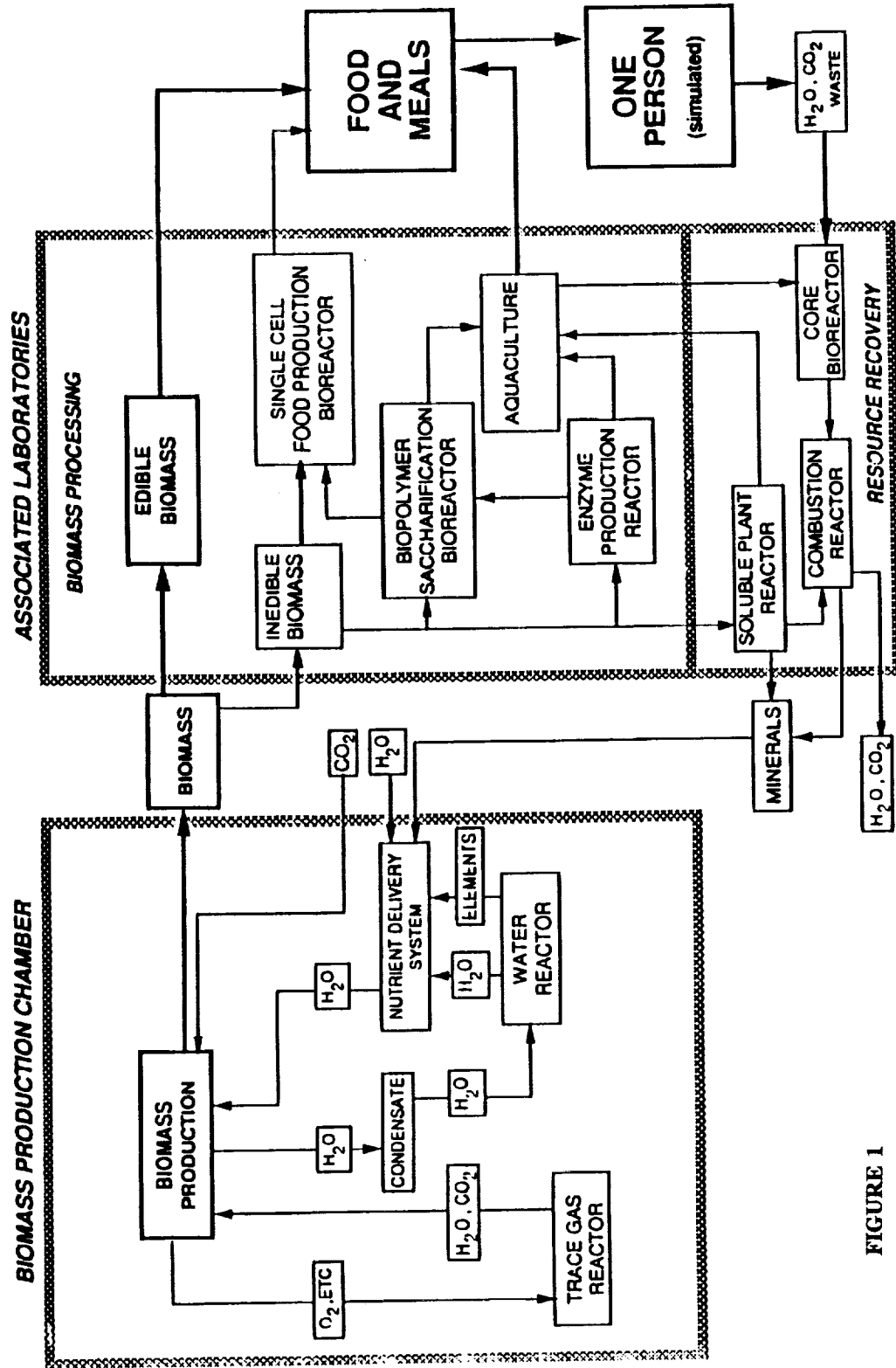
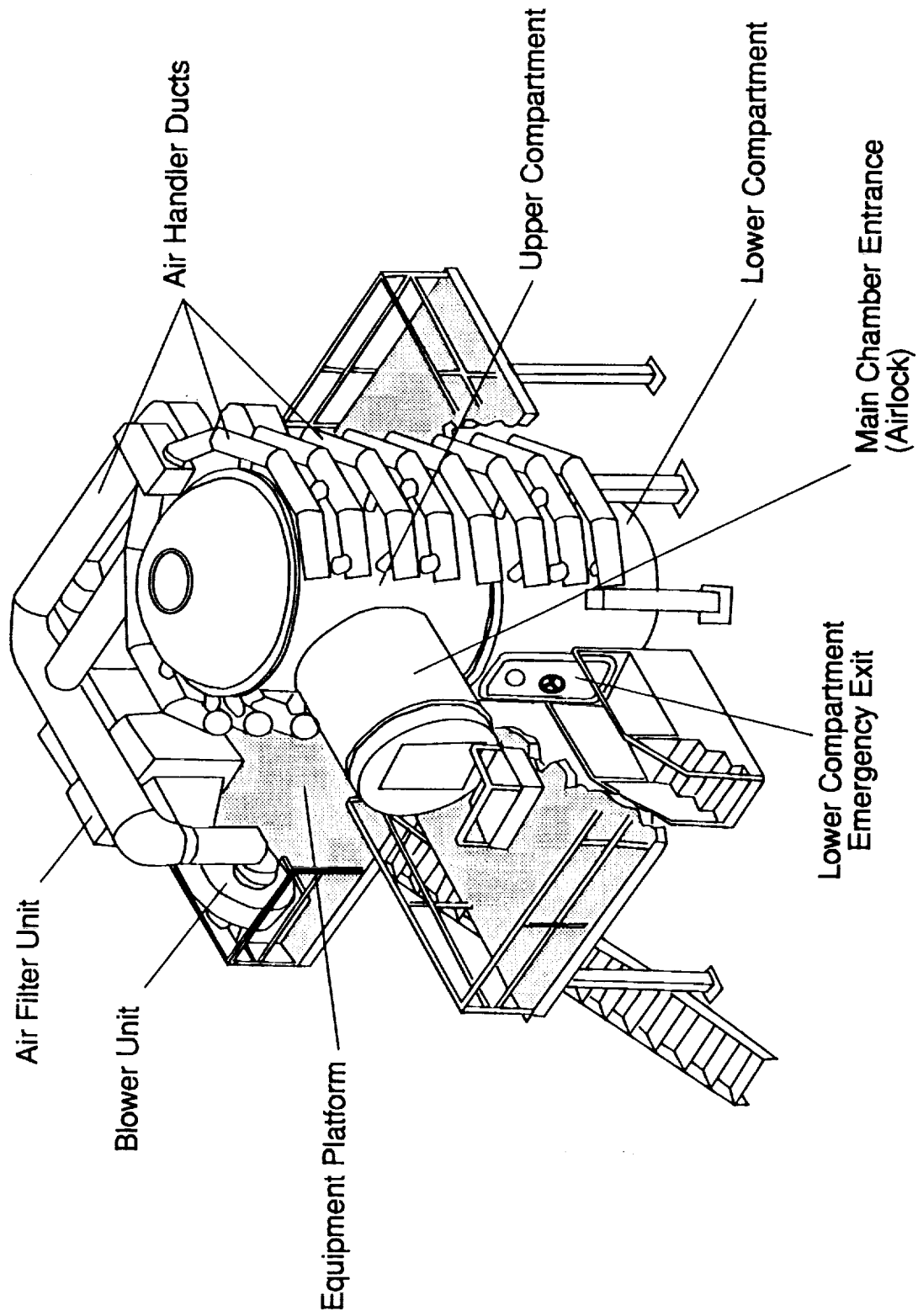

FIGURE 1



The Biomass Production Chamber

FIGURE 2

POROUS TUBE PLANT GROWTH UNIT

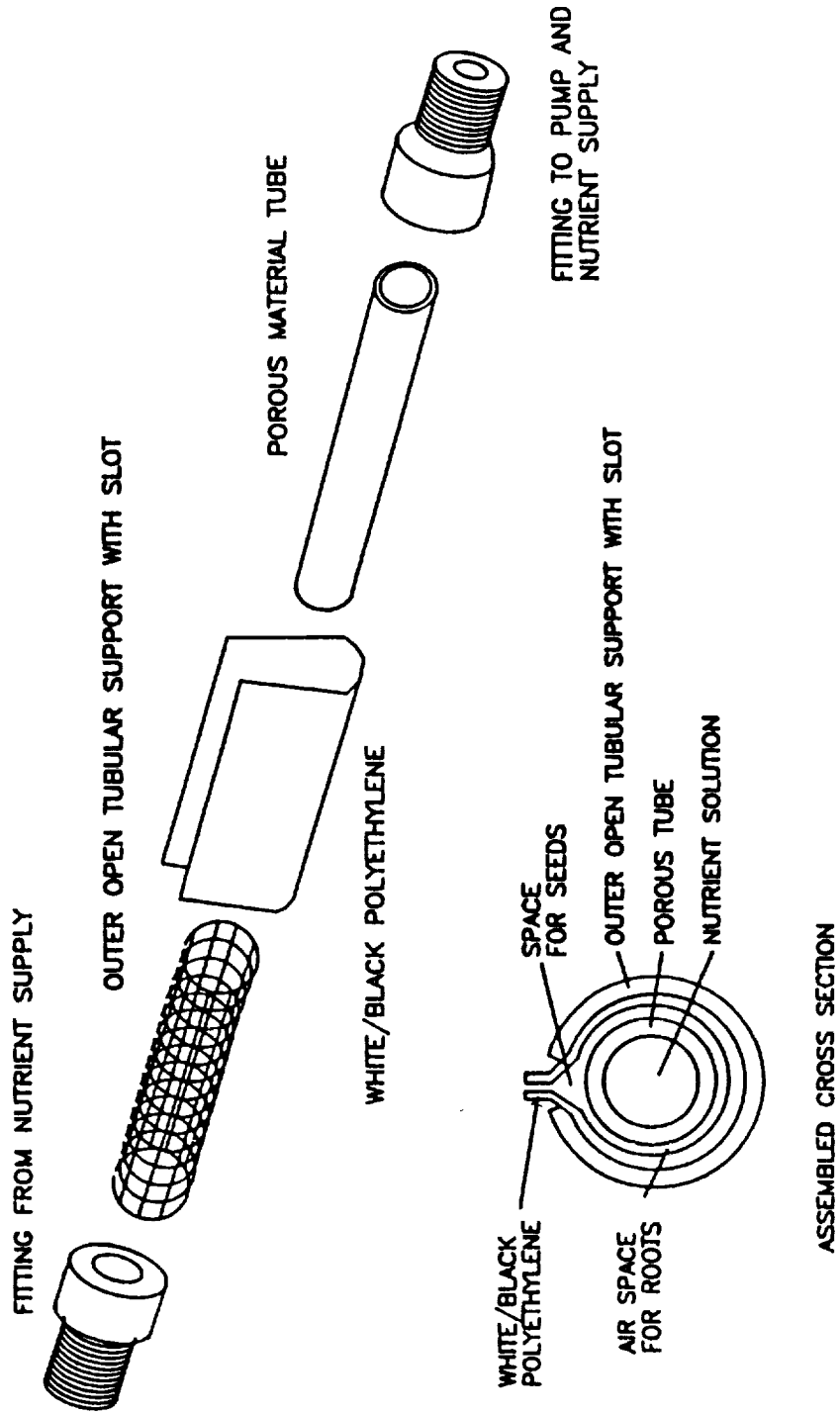
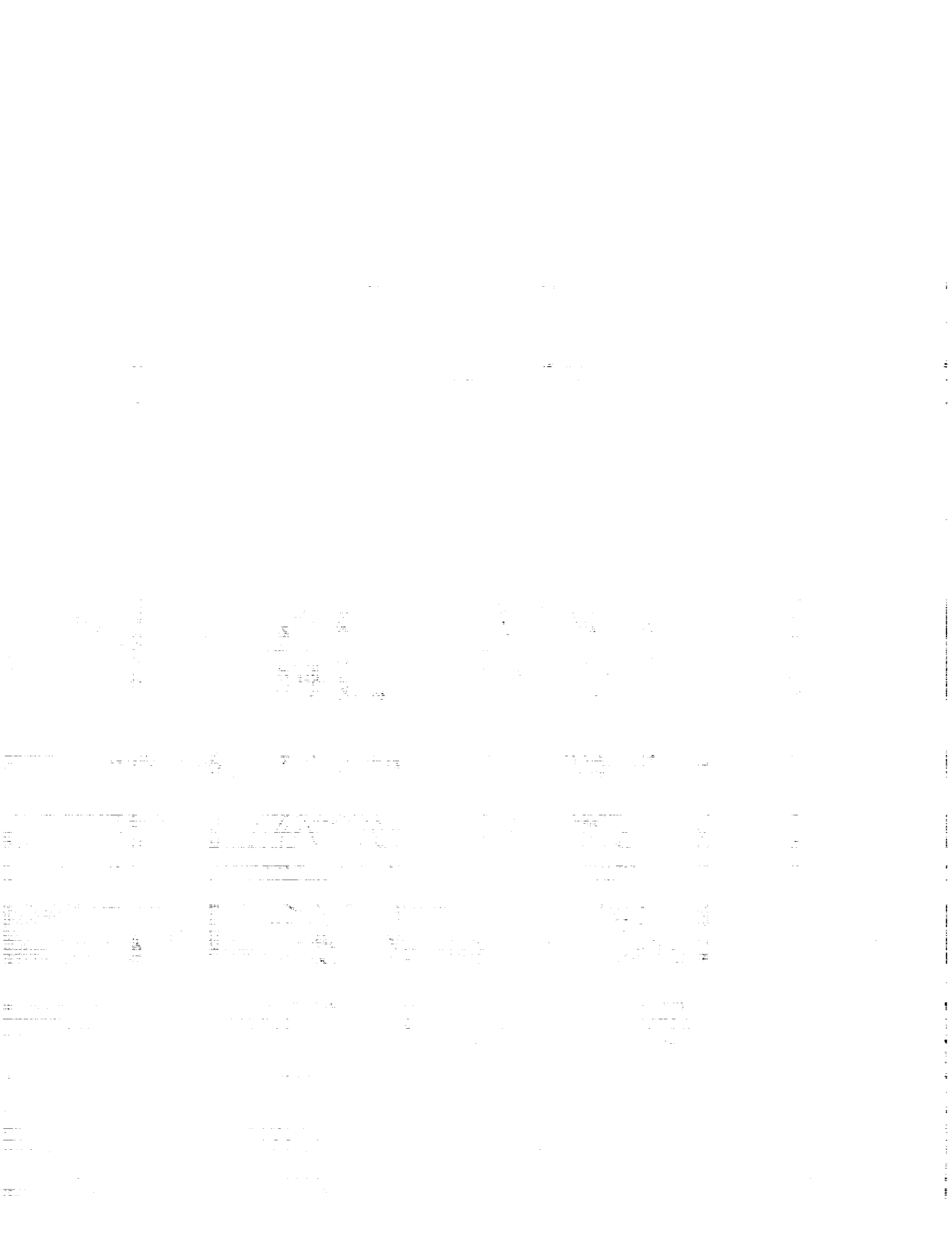

FIGURE 3. SCHEMATIC DIAGRAM OF THE SECOND DESIGN OF THE POROUS TUBE PLANT GROWTH UNIT



SESSION E - MATERIALS SCIENCE (PART 2)

Wednesday November 28, 1990

- **Silicon Carbide, An Emerging High-Temperature Semiconductor**
- **Flexible Fluoropolymer-Filled Protective Coatings**
- **A Conformal Oxidation-Resistant, Plasma-Polymerized Coating**
- **Flame-Retardant Composite Materials**
- **Superplastic Forming Of Al-Li Alloys For Lightweight, Low-Cost Structures**
- **Localized Corrosion Of High-Performance Metal Alloys In An Acid/Salt Environment**

PRECEDING PAGE BLANK NOT FILMED

