

535326

NASA  
S15-20

A UNIQUE HYBRID PROPULSION SYSTEM DESIGN<sup>1</sup>  
FOR LARGE SPACE BOOSTERS

N91-24248  
14729  
P10

Frederick C. Rodgers  
Atlantic Research Corporation  
Gainesville, Virginia

ABSTRACT

A study was made of the application of hybrid rocket propulsion technology to large space boosters. Safety, reliability, cost, and performance comprised the evaluation criteria, in order of relative importance, for this study. The effort considered the so called "classic" hybrid design approach versus a novel approach which utilizes a fuel-rich gas generator for the fuel source. Other trades included various fuel/oxidizer combinations, pressure-fed versus pump fed oxidizer delivery systems, and reusable versus expendable booster systems.

Following this initial trade study, a point design was generated. A gas generator-type fuel grain with pump fed liquid oxygen comprised the basis of this point design. This design study provided a mechanism for considering the means of implementing the gas generator approach and for further defining details of the design. Subsequently, a system trade study was performed which determined the sensitivity of the design to various design parameters and predicted optimum values for these same parameters. The study concluded that a gas generator hybrid booster design offers enhanced safety and reliability over current or proposed solid booster designs while providing equal or greater performance levels. These improvements can be accomplished at considerably lower cost than for liquid booster designs of equivalent capability.

INTRODUCTION

The Challenger tragedy has inspired the accelerated search for safer, more reliable booster designs to replace the current shuttle solid booster as well as to provide a basis for future booster designs for both manned and unmanned systems. Environmental concerns have also stimulated objections to conventional solid booster propellants which generate large quantities of hydrogen chloride as a consequence of using ammonium perchlorate as the principal oxidizer constituent. Efforts are underway to develop new, lower cost liquid propulsion boosters to address these issues. More recently, NASA/MSFC has elected to revisit hybrid rocket technology as a potential, lower cost means of enhancing system safety and reliability. In 1989, NASA/MSFC initiated a contractor study of hybrid rocket technology for application in large space booster systems. The Virginia Propulsion Division of Atlantic Research Corporation (ARC/VPD) with its subcontractor team members formed one of four contractor study teams to address this problem (contract no. NAS8-37776).

The ARC team considered two design approaches during this six-month study, a "classic" hybrid and a "gas generator" hybrid. The classic hybrid approach consists of injecting all or a portion of a liquid or gaseous oxidizer at the head-end of a perforated solid fuel grain. The gas generator approach consists of utilizing a highly fuel-rich gas generator as the fuel source. In this case, the oxidizer is injected into a separate combustion chamber at the aft end of the gas generator where it mixes and burns with the fuel-rich gases from the gas generator. In addition to these two fundamentally different design approaches, the ARC team evaluated a number of fuel/oxidizer combinations, the relative merits of turbopump versus pressure fed oxidizer delivery systems, and the cost saving potential of recoverable versus expendable systems.

Following the initial trade study, a point design was generated based on the selected gas generator design approach. This point design afforded the opportunity of more fully defining the design elements of the selected hybrid approach and provided a basis for assessing cost and reliability elements. Using this point design as a baseline, a series of system trade studies were performed. These trade studies assessed the sensitivity of the booster design to various design parameters and predicted the preferred values for these parameters to yield an overall optimum system in terms of cost and performance. System reliability was estimated by factoring in assessed reliability of individual components and subsystems. The emphasis of this paper is on the description of the point design focusing on the potential advantages of the gas generator approach. Brief summaries of optimization and reliability results are also included.

<sup>1</sup>This work was performed under contract no. NAS8-37776 with the National Aeronautics and Space Administration Marshall Space Flight Center.

SFB

The author wishes to acknowledge Mr. Ben Shackelford, NASA Project Monitor, and ARC's subcontractors which included Boeing Aerospace and Electronics Company, AiResearch Los Angeles Division, Fluid System Division of Allied-Signal Aerospace Company, Aerotherm Division of the Acurex Corporation, and ARC's Liquid Propulsion Division. In addition, major contributors within ARC included Mr. Neil Rossmeissl, Program Manager; Mr. Ken Priggen, Systems Engineering; and Mrs. Sung Lee, Reliability Engineering. A special acknowledgment is extended to Dr. Merrill King of ARC who first proposed use of a gas generator in a hybrid rocket in conjunction with this study and who made many valuable suggestions regarding the implementation of this concept.

Approved for public release; distribution is unlimited.

157 INTENTIONALLY BLANK

PRECEDING PAGE BLANK NOT FILMED

## A HISTORICAL PERSPECTIVE

Review of the history of hybrid rocket technology development reveals that while hybrids have always offered numerous theoretical advantages, the reduction to practice of this technology has typically resulted in somewhat disappointing results. This is particularly true for large space booster designs where the implications of scale have impeded the development of efficient hybrid rocket motors. To understand the root of these historical difficulties, the principles underlying the operation of a hybrid rocket motor must be considered. Figure 1 shows a greatly simplified sketch of a so-called classic hybrid system. The typical design arrangement consists of a center perforated fuel grain with injection of a liquid or gaseous oxidizer at the head end of this grain. Some designs bypass a fraction of the oxidizer around the grain and introduce it downstream in a mixing chamber. The interaction of the oxidizer with the fuel as it passes over the surface of the grain results in grain regression and the subsequent combustion of this fuel that has been removed from the grain surface with the oxidizer as the two constituents flow down the grain port.

There are several important keys to the efficient performance of the classic hybrid. First, an optimum oxidizer-to-fuel mixture ratio must be maintained at all times to derive maximum specific impulse and total booster impulse. Second, mixing between the released fuel and the oxidizer in the grain port must be achieved to a high degree in order to attain high impulse efficiency. Finally, the regression of the grain must be such that the fuel is fully utilized leaving no unconsumed slivers of fuel in the motor.

Grain regression is a very complex process in hybrid motors involving a number of interrelated phenomena. Fundamentally, fuel is removed from the surface of the grain either by mechanical erosion due to the viscous forces of the gaseous flow, by combustion with the oxidizer in or near the boundary layer, or by a combination of both. These processes are, in turn, influenced by complex phenomena occurring in the boundary layer which are driven by the core flow and by the combustion process itself. Heating of the solid fuel grain near the surface due to the ongoing combustion processes also influences subsequent regression of the grain. Addition of mass to the boundary layer due to grain regression contributes yet another influence. Typically, regression rates in a 100% fuel grain are considerably lower than desired. The regression rate is often enhanced by adding to the fuel oxidizer such as ammonium perchlorate, blowing agents, and/or catalysts.

Once the fuel has been removed from the grain, it must be thoroughly mixed with the core flow so that sufficient oxidizer will be available locally to react with the fuel. Also, optimum motor performance requires the gas flow entering the nozzle to be one dimensional in terms of velocity, temperature, and chemical species concentration. Attaining this homogeneous mixture becomes increasingly difficult as the port diameter increases. Needless to say, insufficient mixing results in performance deficiencies.

Another implication of grain regression in a hybrid motor is that the regression rate is typically not constant over the length of the grain nor are the relative regression rates at different axial locations constant with time. Tailoring grain regression is typically accomplished by proper design of the grain geometry and by control of core flow properties such as velocity. This adds considerable complications to the grain design and commonly results in inefficient fuel usage due to grain slivering. Multi-port grain designs are often used to mitigate this problem. Effectiveness of the grain design in avoiding grain sliver is greatly dependent upon maintaining the oxidizer flow schedule for which it was designed. Deviations from this flow schedule which are desirable to permit flexible throttling of the engine often alter the grain regression profile from the original design.

The difficulties discussed in the previous paragraphs are not insurmountable, and in fact, considerable progress has been made in the development of larger sized hybrid motors. However, a major problem with development of large hybrid motors is that the phenomena of regression and mixing are quite sensitive to scale, and scaling models, to date, have been complex and unreliable. Thus, considerable development effort is required with large scale test hardware in order to gain adequate confidence in the final, full scale design. In light of these complexities, the ARC team elected to evaluate an alternative hybrid design approach which we refer to as the "gas generator" approach. Figure 2 shows a simplified diagram of a gas generator hybrid design. The key element of the gas generator approach is that grain regression is uncoupled from fluid dynamic interaction with the oxidizer flow. The fuel-rich grain contains sufficient oxidizer to sustain regression of the grain surface without the influence of a flowing gas across its surface. Liquid or gaseous oxidizer is injected downstream of the grain into a separate combustion chamber. Here the oxidizer and the fuel-rich gases from the gas generator mix and combust. This approach is analogous to the design of air-breathing propulsion systems known as ducted rockets. Considerable technology development efforts have been expended on various ducted rocket designs which use air as the oxidizer source. However, an analogous data base related to the use of fuel-rich gas generators in conjunction with an on board oxidizer source is not known to exist. The initial

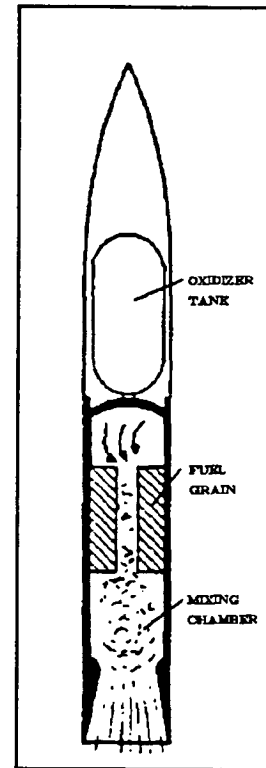

Figure 1  
Classic Hybrid

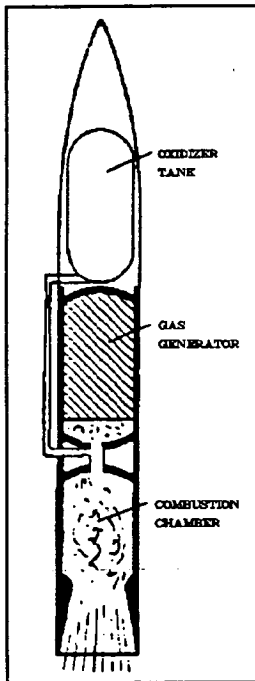

Figure 2  
Gas Generator Hybrid

design trade study sought to more fully assess the application of this design approach to large space boosters and to compare relative reliability, safety, cost, and performance levels with the classic hybrid design approach.

#### INITIAL DESIGN TRADE STUDIES

In addition to the two basic design approaches previously discussed, a wide variety of options with regard to key elements of the system design existed. These options included: fuel/oxidizer combinations, pump fed versus pressure-fed, reusable versus expendable, metal versus composite materials, and the method of supplying thrust vector control (TVC). An initial trade study was performed in order to reduce these options to a manageable number.

The statement of work for the Phase I study program defined a set of requirements for the hybrid booster design. Two booster sizes were to be considered - a full-size booster which was to be capable of delivering the vacuum thrust trace shown in Figure 3 and a quarter-size booster which was to generate a thrust trace having a general magnitude one-fourth of the trace shown. The full-size booster was considered to be one of two boosters strapped to an undefined core vehicle. The quarter-size booster represented one of eight identical boosters, again strapped to a common core. Conclusions drawn from the study of both vehicles were quite similar; for the sake of brevity, only the full-size booster is discussed in this paper. In addition to the required

thrust trace, a number of other system requirements were also defined. These are summarized in Table I.

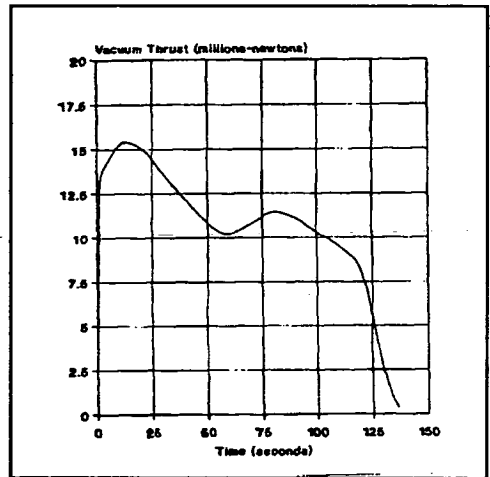

Figure 3 Required Vacuum Thrust Profile

Table I. System Requirements

- Safety and reliability requirements shall be identical for manned and unmanned systems.
- Concepts shall minimize environmentally degrading exhaust products.
- The solid propellant grain shall extinguish when the fluid oxidizer flow is stopped; no restart requirement.
- Concepts shall utilize active control systems for performance, thrust imbalance, propellant utilization, and all transients.
- Concepts shall use thrust vector control (TVC).
- Recoverable and reusable concepts versus expendable concepts shall be evaluated.
- Concepts shall maximize shelf life.
- Concepts shall not use asbestos-containing materials.

A number of propellant combinations were considered. These combinations were first evaluated by generating thermochemistry calculations which predicted theoretical specific impulse, products of combustion, and combustion temperature. Optimum mixture ratios were determined by examining the specific impulse from these thermochemistries as a function of mixture ratio. Early on, the list of oxidizers was reduced to liquid oxygen (LOX) and hydrogen peroxide. Other oxidizers considered were eliminated because they were either toxic, corrosive, detonable, or too expensive. LOX is a low-cost, high-performance oxidizer which has been used on virtually all of NASA's large manned liquid-propellant space boosters including the shuttle. Hydrogen peroxide has a substantial history of usage in rocket motors both as an oxidizer and as a monopropellant. Compared with LOX it provides somewhat lower performance and is higher in cost. However, hydrogen peroxide has approximately 24% higher density than LOX and does not require storage at cryogenic temperatures. This latter fact greatly simplifies concerns with thermal mismatch, insulation requirements, and design of the oxidizer delivery system. It is nontoxic and, as a monopropellant, can be used to drive turbopumps, assist in tank pressurization, and provide an energetic working fluid for thrust vector control. The desire to gasify the oxidizer before injecting it into the head end of a classic hybrid motor also makes hydrogen peroxide attractive. Its major drawbacks are that it is not currently manufactured in the United States in high purity and that a lack of

recent working experience exists with this oxidizer.

Fuels were classified in two general categories - metal-containing and hydrocarbon-based fuels. Thermochemical data revealed that common metals such as aluminum provided no performance benefit in combination with either of the two oxidizer candidates. Subsequently, a single hydrocarbon-based fuel source was selected for each design approach. The description of each of these fuels is provided in Table II. The fuel formulation selected for the classic design approach contains no oxidizer constituent although it is recognized that some oxidizer may be required to provide an adequate grain regression rate. This fuel in combination with either of the two selected oxidizers meets the program's clean exhaust requirements and its combustion will extinguish when the oxidizer flow is shut off. The gas generator fuel contains ammonium perchlorate oxidizer in order to make it self-sustaining. Since this fuel will generate hydrogen chloride when burned, a means of eliminating this product was required. This was accomplished by adding sodium nitrate to the fuel. When burned, the sodium from the sodium nitrate will scavenge the chlorine molecule creating sodium chloride thus effectively eliminating the harmful hydrogen chloride product. While experimental evaluation was beyond the scope of the Phase I study, it is believed that the extinguishability requirement can be met for the gas generator approach by combination of fuel tailoring and engine design. This will be discussed further in the section on the point design.

Table II. Fuels Description

<u>Classic</u>	<u>Gas Generator</u>
25% Polystyrene	34.0% Polystyrene
75% Hydroxy-terminated Polybutadiene (HTPB)	29.0% HTPB
	21.5% Ammonium Perchlorate
	15.5% Sodium Nitrate

Propellant requirements to meet the prescribed vacuum thrust profile were calculated for each of the four unique propellants derived from the selected fuel/oxidizer combinations. These calculations assumed a chamber pressure at liftoff of 7.57 MPa (1000 psia) and an exit-to-throat area ratio of fifteen. Booster system layouts were generated for both turbopump and pressure-fed oxidizer delivery systems for each propellant combination yielding a total of eight system layouts. Each system design assumed a booster diameter of 3.7 m (12 ft). Material selection made extensive use of composites for the oxidizer tank and motor cases, particularly for the pressure-fed systems. Previous studies showed that pressure-fed systems cannot compete with turbopump systems if all-metal construction is assumed. Weight breakdown estimates for each system were made and life cycle costs for each were generated. The life cycle costs assumed one flight per month for ten years.

Results of this effort are given in Table III. These results show that (1) classic hybrid designs were 0.5 to 2.5% lighter than equivalent gas generator hybrids; (2) systems using LOX were 7 to 10% lighter than systems using hydrogen peroxide, but they were also 5 to 17% longer due to the lower density of LOX; and (3) turbopump systems were 2% lighter than the pressure fed options, and 33 to 68% lower in cost. Additional conclusions drawn from this study were: (1) use of composites in large structural components provides substantial performance improvement; (2) pressure-fed systems benefit the most from the use of composites; and (3) the benefits of using composites for expendable systems warrant continued consideration and development. The life cycle cost study indicated that the lowest cost system was the gas generator design with turbopump delivery system. The highest cost system was a classic design using a pressure-fed delivery system. From this initial study, the ARC team decided to pursue development of a point design for a gas generator system using turbopumps to deliver LOX to the thrust chamber. This approach offers the required levels of safety and reliability at the lowest life cycle cost and development risk of those hybrid designs considered.

#### POINT DESIGN

The point design effort performed two important functions. First, it served to further define the best means of implementing the gas generator approach into a booster design that yields the safest and most reliable system while meeting performance requirements and minimizing cost. Second, it provided a baseline for the trade optimization studies and helped to confirm the validity of the optimization model. Therefore, while the point design does not represent an optimized system, it does provide a good indication of the potential of this design approach.

Table III. Concept Summary

ID No.	Hybrid	Oxidizer	Feed System	Weight*	Length+	LCC (%)***
1	GG**	H <sub>2</sub> O <sub>2</sub>	Pressure	597	4978	166.5
1T	GG	H <sub>2</sub> O <sub>2</sub>	Turbopump	580	4539	117.3
1A	GG	LOX	Pressure	553	5532	133.6
1AT	GG	LOX	Turbopump	543	5819	100.0
2	Classical++	H <sub>2</sub> O <sub>2</sub>	Turbopump	594	5560	189.0
2T	Classical	H <sub>2</sub> O <sub>2</sub>	Turbopump	---	----	120.9
2A	Classical	LOX	Pressure	540	5837	168.0
2AT	Classical	LOX	Turbopump	530	5494	111.4

+ In centimeters.

\* In thousands of kilograms.

\*\* Gas generator fuel was as described in Table II

++ Classical hybrid fuel was as described in Table II

\*\*\* Compared to the gas generator hybrid with pump-fed LOX.

Definition of the point design emphasized the maximization of system safety and reliability. To this end, several key design decisions were made. First, a conservative safety factor of 1.6 was selected for the sizing and analysis of all structural components. Next, redundancy in the oxidizer delivery system design was enhanced by electing to use four turbopumps which would be over-sized such that 100% of oxidizer flow rate requirements could be met even with the loss of one pump. Finally, a conscious effort was made to emphasize design simplicity even at the expense of maximum performance.

A layout sketch of the point design is given in Figure 4 and a weight breakdown is supplied in Table IV. The oxidizer tank is located at the forward end of the booster and sits atop the gas generator. Its outer diameter has been increased from the initial study to 434 cm (171 in). Two feed lines are located at the aft end of the tank which deliver LOX to the oxidizer plenum at the aft end of the gas generator. The four turbopumps are driven by bleed taken off the aft end of the gas generator. Fuel rich gases from the gas generator are exhausted through multiple ports in the injector manifold into a separate thrust chamber. Here these gases mix and react with LOX. The thrust chamber is an ablative design and thrust vector control is accomplished by liquid injection into the nozzle using LOX as the working fluid. Details of the propellant formulation and predicted combustion properties are provided in Table V.

**GAS GENERATOR**

The design of the gas generator was driven by fuel flow rate and total fuel requirements for the specified thrust duty cycle. Characteristics of the fuel such as the burning rate equation were assumed using data from similar formulations as a guide. The optimum mixture ratio (MR, oxidizer-to-fuel flow rate) was determined to be approximately 1.4 based on maximum vacuum thrust impulse. The theoretical vacuum specific impulse is fairly insensitive to mixture ratio over the range of 1.25 to 1.5 as seen in Figure 5, so some latitude in the grain design is afforded. Total fuel requirements assumed a specific impulse efficiency of 92.5% and a fuel sliver fraction (unburned residue) of 2%. An outer diameter of 386 cm (152 in) was selected for the fuel grain design. This is considered to be within the current industry manufacturing and transportation experience base. The increase in diameter compared with the initial study effort was selected to reduce vehicle length and to improve vehicle aerodynamics. 209,911 kg (462,774 lb) of the solid, fuel-rich propellant are needed to meet total impulse requirements. An additional 3,402 kg (7,500 lb) are required to drive the turbopumps which will be further discussed later. The resulting grain length is 1,6235 cm (640 in) and the grain port is 79 cm (31 in). Axial and cross-sectional grain views are shown in Figure 6.

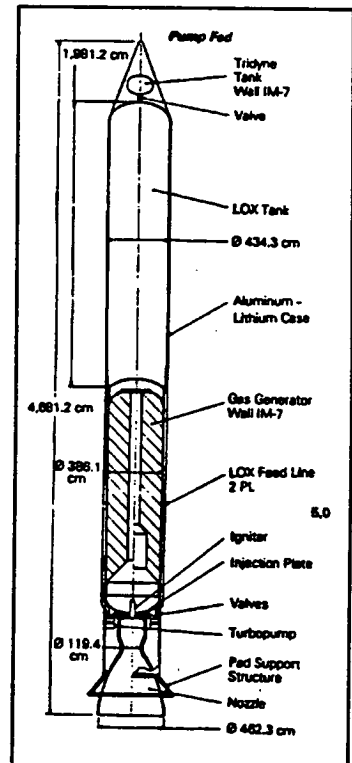

Figure 4  
Point Design

Table IV. Full-Size Vehicle Weight Breakdown (Turbopump).

<u>Subsystem</u>	<u>Element</u>	<u>Weight (kg)</u>
Gas Generator	Fuel	213,313
	Case	7,541
	Liner/Insulation	644
	Igniter	45
Oxidizer Delivery System	LOX	299,700
	Tank (Al-Li)	4,213
	Feed Lines	170
Pressurizing System	Tridyne/Inert	1,124
Turbopumps		816
Thrust Chamber	Injector Manifold	1,134
	Chamber	8,174*
Ancillary Components	TVC	892
	External Insulation	2,428
	Interstage	594
	Nose Cone	497
	Skirt	2,631
	Thrust Transfer Ring	680
Total Weight		544,596 (1,200,608 lb)

\* A regeneratively cooled thrust chamber would have an estimated weight of 6,350 kg.

Table V. Gas Generator Hybrid Propellant

Mixture Ratio = 1.4

Combustion Properties

Flame Temperature Without LOX (K)	1277 K
Flame Temperature With LOX (K)	3628 K
Density of Gas Generator Fuel (g/cm <sup>3</sup> )	1.2
C* of Gas Generator Fuel (m/sec)	982
C* of Gas Generator Fuel and LOX (m/sec)	1,686

Major Exhaust Products

(moles/100 grams)

	<u>Gas Generator</u>	<u>Thrust Chamber</u>
H <sub>2</sub> O	0.376	11.372
C	3.262 (solid)	
CO	0.718	0.691
CO <sub>2</sub>		1.185
CH <sub>4</sub>	0.600	
N <sub>2</sub>		0.076
NaCl	0.182 (liquid)	0.044

Emergency shutdown of the hybrid motor by extinguishment of the grain is a requirement for this study. Certain fuel-rich propellants are known to extinguish at sufficiently low pressure levels. This is called the lower pressure deflagration limit or  $P_{dl}$ . During the Phase I study it was assumed that a suitable fuel-rich propellant could be formulated which had a  $P_{dl}$  of as high as 2.06 MPa (300 psia). Subsequent studies indicate that the  $P_{dl}$  limits will most likely be less than 0.7 MPa (100 psia). To reduce gas generator pressure to this level, the gas generator must be in communication with the thrust chamber. That is, the gas generator must be unchoked (no sonic point or throat). Then when LOX flow is shut off, the chamber pressure (and gas generator pressure) will fall below the  $P_{dl}$  limit if the engine has been properly designed and if the gas generator fuel has the appropriate combustion characteristics.

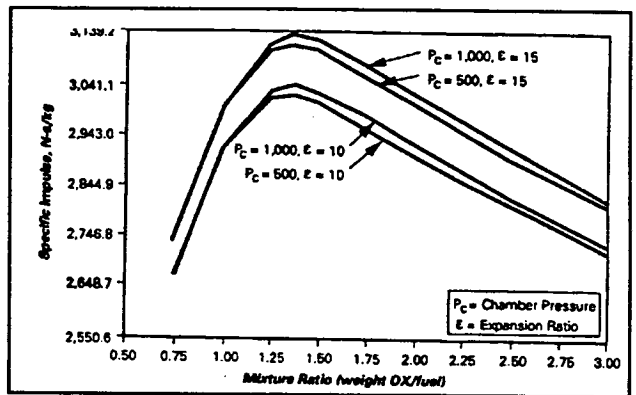

Figure 5 Specific Impulse versus Mixture Ratio

The inability of the gas generator fuel to burn at low pressure adds one problem - how to initiate the combustion process in the grain. This problem can be remedied by overcasting a second propellant, which has low pressure burning capability, over the main fuel grain or alternatively, installing a separate cartridge into the gas generator loaded with this "start-up" propellant. This second propellant will burn only long enough to spool up the turbopumps and establish stable LOX flow into the thrust chamber. Secondary combustion in the thrust chamber will drive the gas generator pressure above the  $P_{dl}$  of the main propellant thus allowing it to burn steadily.

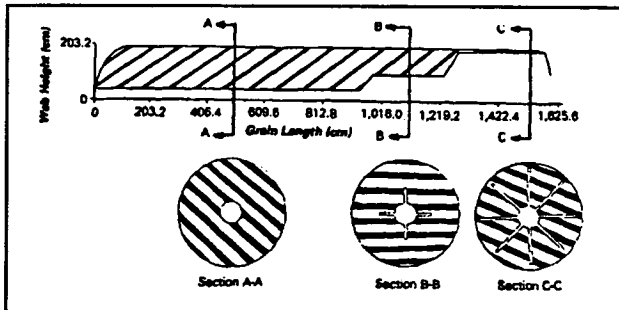

Figure 6 Gas Generator Grain

Ignition of the gas generator is accomplished by a small igniter located at the aft end of the gas generator. This igniter may be installed after the booster is on the launch pad and shortly before launch which would enhance the level of safety of the system while it was being assembled on the launch pad.

The gas generator case is constructed of graphite (IM7) - epoxy, filament wound composite. The case is monolithic with steel polar bosses at both ends. The case insulation consists of HTPB with glass micro-balloons which was selected, in part, because of its low density of  $1.05 \text{ gm/cm}^3$  ( $0.038 \text{ lb/in}^3$ ). It has a maximum thickness of 1.3 cm (0.5 in) which occurs at the exposed aft end of the case. The insulation thicknesses are minimal due to the relatively low flame temperature of the gas generator propellant [ $1,278\text{K}$  ( $2,300^\circ\text{R}$ )]. This provides substantial weight savings when compared to insulation requirements for solid propellant or classic hybrid motors.

#### THRUST CHAMBER

A sketch of the ablative thrust chamber design is shown in Figure 7. The thrust chamber throat diameter of 119.4 cm (47 in) was selected to provide a nominal chamber pressure of 7.57 MPa (1000 psia) which occurs at liftoff. An exit to throat area ratio of 15 was then chosen to maximize vehicle performance. A bell-shaped nozzle geometry is used and the resulting exit diameter is 462 cm (182 in). The chamber diameter was selected to give a two-to-one area ratio with the nozzle throat which is within the range of normal values for thrust chambers. The resulting chamber diameter is 169 cm (66.5 in). A conservative  $L$  of 305 cm (120 in) was selected in the absence of an experimental data base for the concept. This yields a chamber length (cylinder section only) of 147 cm (58 in) and a residence time of 4.3 msec.

The thrust chamber is constructed of ablative materials beginning with a 3D-reinforced, glass-phenolic monolithic braided ablative (MBA) shell and a 3D carbon-carbon throat insert. The MBA shell offers advantages over conventional laminated multi-ring designs typical of shuttle SRM nozzles in that (1) ply-lifting/delamination is eliminated via a 3D reinforced architecture, (2) leak paths due to

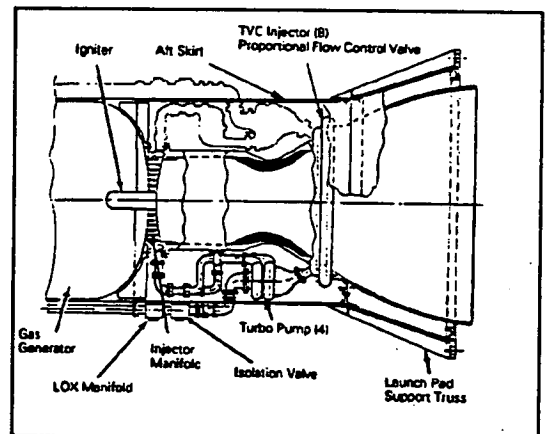

Figure 7 Thrust Chamber

multi-component interfaces and bondlines are reduced, and (3) manufacturing is simplified via automation, low raw material costs and reduced scrap due to near-net molding. Approximately 10% of the relatively cool, fuel-rich gases from the gas generator are channeled along the chamber wall to reduce heat transfer and to provide oxidation protection. At an expansion ratio of about 5.7, the thermal environment is sufficiently benign to allow the glass/epoxy overwrap to perform as both thermal protection and structural support.

### INJECTION MANIFOLD

The injection manifold (detail shown in Figure 8) feeds both liquid oxygen and fuel-rich gases from the gas generator into the thrust chamber. Since the gas generator exhaust is relatively cool, it is feasible to inject this gas into the thrust chamber through multiple passages or injection ports. For the purposes of illustration, approximately 500 of these ports are used in the injection manifold. Each port has a cylindrical cross-section and is approximately 3.9 cm (1.55 in) in diameter. Each of these ports consists of a steel tube passing between upper and lower domes of the manifold. The maximum pressure drop across these ports will be on the order of 0.34 MPa (50 psi). Eight pairs or doublets of oxidizer injector ports are spaced around each fuel port. These ports are approximately 0.33 cm (0.131 in) in diameter and will experience a pressure drop at maximum flow rate of around 1.72 MPa (250 psi). The LOX stream from each doublet member will impinge on the stream from its opposite member as well as the fuel stream about 3.8 cm (1.5 in) from the injector face.

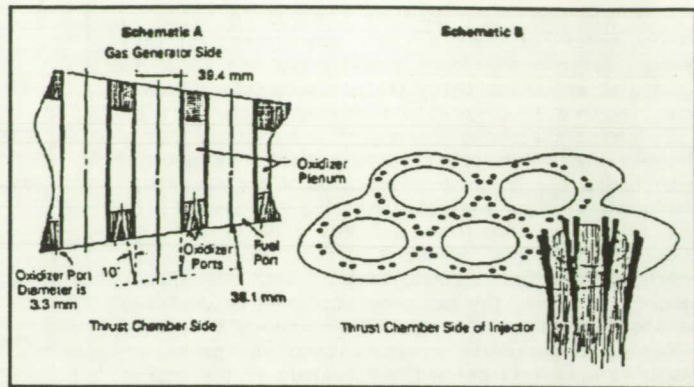

Figure 8 Propellant Injector Manifold

Fuel ports near the chamber wall will not be coupled with LOX injectors. These ports will direct roughly 10% of the total fuel flow down along the chamber wall for wall cooling and oxidation protection. Most of this fuel will react before leaving the thrust chamber so the penalty in impulse efficiency will be small.

As previously discussed, the flow through the fuel ports will be highly subsonic to permit pressure "communication" between thrust chamber and gas generator. Refinement of the injector design will undoubtedly be required once the fuel properties are characterized and experimental combustion data are available.

### LOX DELIVERY SYSTEM

A schematic of turbopump LOX delivery system is given in Figure 9. The total LOX required for the mission was estimated to be 299,700 kg (660,725 lb) which consists of 281,681 kg for boost propulsion, 12,143 kg for thrust vector control, and a reserve of 2% or 5,876 kg. The LOX tank is made from aluminum-lithium alloy and has a reverse aft dome for efficient packaging. Positive suction head is provided by a small tank of Tridyne gas (a mixture of helium, hydrogen, and oxygen) which sits on top the LOX tank. Two stainless steel feedlines each 20.3 cm (8.0 in) in diameter feed the LOX from the aft end of the LOX tank to a common toroidal plenum located at the aft end of the gas chamber. Four turbopumps spaced around the thrust chamber draw the LOX from this plenum and deliver it to the oxidizer injection plenum at a maximum pressure of 9.5 MPa (1380 psia). Gases bled from the gas generator are used to drive the turbines. A reverse pitot separates particulate from these bleed gases before they enter the turbine. Each turbopump (see Figure 10) is a single-stage, mixed-flow design with a 22.9 cm (9.0 in) impeller tip diameter. The turbine uses a single-stage, impulse impeller with a 48.3 cm (19 in) tip diameter. The turbopump design uses foil bearings rather than conventional ball bearings for higher reliability.

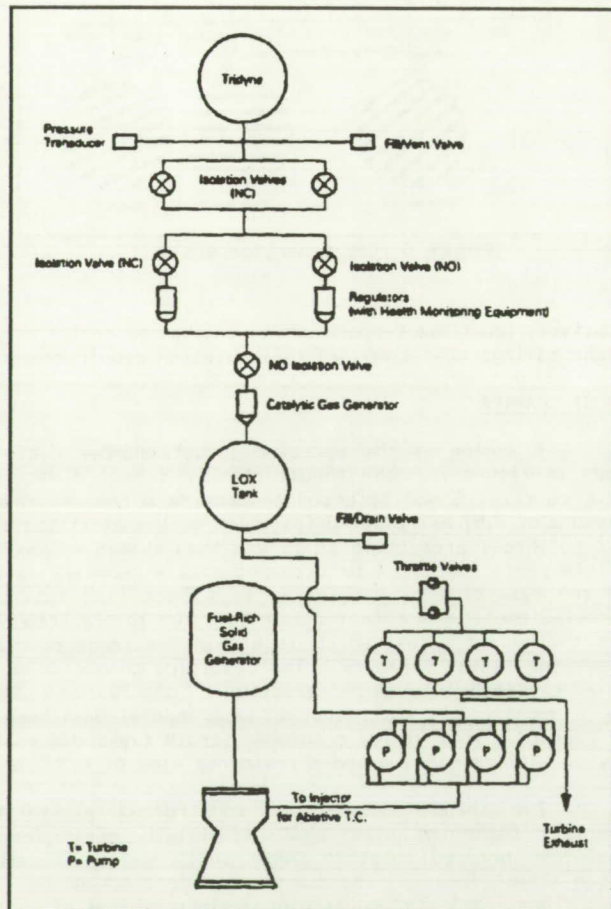

Figure 9 LOX Delivery System Schematic



## THRUST VECTOR CONTROL SYSTEM

Most of the thrust vector authority required by the current shuttle solid rocket booster is a result of potential thrust mismatch between the two solid boosters. Differential throttling of hybrid booster systems should eliminate most of this requirement reducing the required thrust authority to 2° to 3° for attitude adjustments. This requirement is within the effective range of fluid injection thrust vector control (FITVC). Fluid injection TVC provides substantially higher reliability compared with flexured nozzle designs.

After considering several other working fluids, LOX was selected. Figure 11 gives the predicted LOX flow rate requirements as a function of thrust deflection angle or ratio of side force to main thrust. The LOX used in the FITVC system is drawn from the injector plenum and is injected into the nozzle through one or more equally spaced injectors located at a nozzle expansion ratio of five. A duty cycle of 150 degree-seconds was assumed which resulted in an estimated LOX requirement of 12,143 kg (26,770 lb).

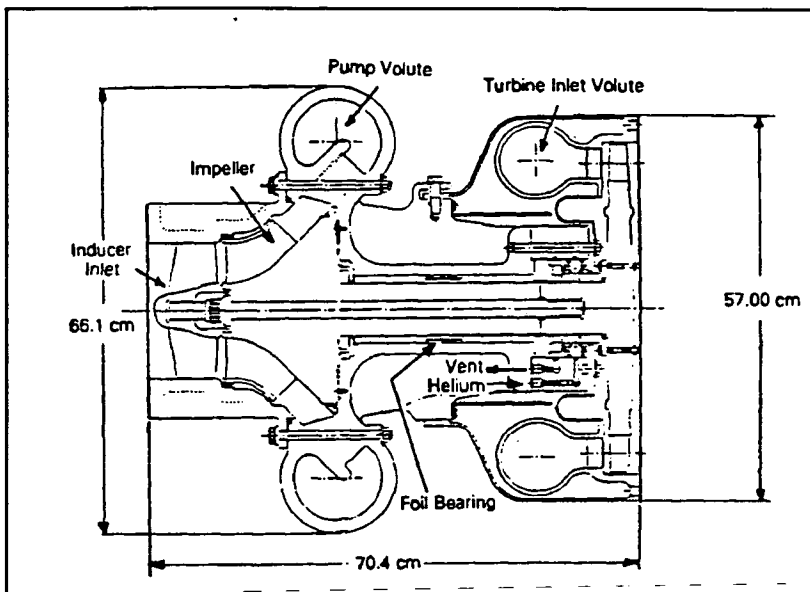

Figure 10 LOX Turbopump

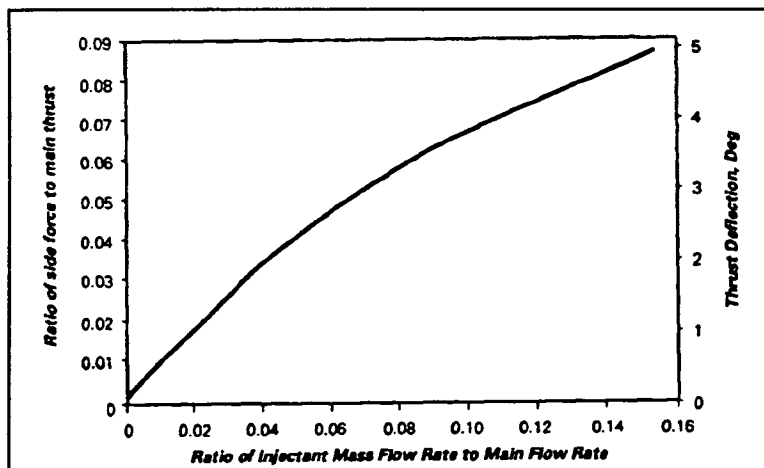

Figure 11 FITVC Operating Characteristics

## OPTIMIZATION AND RELIABILITY STUDIES

Using Boeing's Hypervelocity Aerospace Vehicle Conceptual Design (HAVCD) computer code, major design parameters were selected which rendered the optimum booster design based on life cycle cost (LCC). The basis for the LCC study was one mission per month for a period of ten years. The system predicted to yield the lowest cost over its operating lifetime has a turbopump oxidizer delivery system and is characterized by the major design parameters defined below:

Mixture Ratio = 1.6  
 Chamber Pressure = 12.8 MPa (1860 psia)  
 Vehicle Diameter = 4.8 m (15.8 ft)  
 Nozzle Expansion Ratio = 22.5

The optimizer code predicted a LCC value of \$11.4 billion. By comparison, the LCC for the reference or point design is predicted to be 2.2% greater. This result is a consequence of selecting a higher chamber pressure in the optimized design compared with the reference design and is specific for a turbopump-fed system design. A pressure-fed system design optimizes at a chamber pressure close to that of the reference design (7.57 MPa or 1000 psia). Payload capability assuming a shuttle-type core vehicle is 33,200 kg (73,000 lb). The use of recoverable or partially recoverable systems was estimated to reduce LCC by about 2% for the scenario assumed. However, the reduction in payload carrying capability is on the order of 3% for a recoverable system so the cost per pound of payload to orbit may actually increase. One of the most significant results of the LCC study was that extensive use of composite materials in major structural elements offers substantial increase in payload carrying capability and reduction in LCC.

The calculated reliability of each booster is .9987. This is slightly below the goal of .9995, and is primarily due to the lack of a sufficient data base for a number of elements such as composite structures. In the absence of hard statistical data, somewhat conservative reliability assumptions were made.

ORIGINAL PAGE IS  
 OF POOR QUALITY

## CONCLUSIONS

Hybrid propulsion technology can provide the required levels of reliability and safety for future manned and unmanned launch vehicles at a cost that is considerably lower than for equivalent liquid propulsion systems. The primary shortcoming of hybrid propulsion technology is its lack of development maturity. The gas generator hybrid propulsion design approach offers a shortcut to acquiring this maturity. The primary advantage that the gas generator approach presents over the classic hybrid approach is that it decouples grain regression from the complex fluid-dynamic processes associated with the flow of oxidizer down the grain core. This greatly simplifies design of the grain geometry and development of the propulsion system. Other advantages of the gas generator approach include: (1) enhanced mixing of fuel and oxidizer using a multi-port injector design; (2) cooling and oxidation protection of the thrust chamber by injection of fuel along the chamber walls; (3) a power source for the turbopumps; and (4) a substantially less severe thermal environment in the grain case which reduces insulation requirements.

Characteristics/advantages shared by both hybrid propulsion approaches include: (1) thrust termination and extinguishment capability; (2) throttling capability which provides enhanced mission flexibility and reduced thrust vector control requirements; (3) safer propellant mixing and casting since in both cases the solid fuel is essentially inert at ambient pressure; and (4) no toxic exhaust products.

The gas generator hybrid propulsion design developed by the Atlantic Research team provides several other features which enhance system safety and reliability. Among these are: (1) multiple, over-sized turbopumps which provide full mission capability even with one pump out; (2) fluid injection thrust vector control which eliminates the need for mechanically actuated, massive hot structure such as the flexured nozzle design; and (3) a monolithic braided, ablative thrust chamber which provides much more failure tolerance than either regeneratively cooled thrust chamber or fiber wrapped ablative nozzle designs.

The advantages of large hybrid booster propulsion systems for future space launch missions are substantial. The desire to greatly enhance the safety and reliability can be satisfied while simultaneously improving performance of the vehicle in terms of payload-to-orbit capability. The life cycle cost of the operational system is commensurate with the current Shuttle Advanced Solid Rocket Motor and considerably lower than projected costs for pressure fed liquid boosters of equivalent capability. The reduction in development effort for a gas generator hybrid is considerable compared with that for a classic hybrid approach. The feasibility of the gas generator hybrid can be fully demonstrated in small scale testing whose results can be expected to be directly extrapolatable to full scale systems.