

S33-20
N91-24266

P.9

HELIUM SATURATION OF LIQUID PROPELLANTS

A. H. Yavrouian
Space Materials Science and Engineering Section
C. M. Moran
Propulsion and Chemical Systems Section
Jet Propulsion Laboratory
California Institute of Technology
Pasadena, California

JJ57448

ABSTRACT

The work described in this paper is threefold:

- (1) Devise techniques for achieving the required levels of helium (He) saturation in liquid propellants. This paper restricts its discussion to monomethylhydrazine (MMH) and nitrogen tetroxide (NTO).
- (2) Evaluate the values for equilibrium solubilities of He in liquid propellants as currently used in the industry.
- (3) Accurately measure the He dissolved in liquid propellants.

Conclusions drawn from these studies include:

- (1) Techniques for dissolving He in liquid propellants depend upon the capabilities of the testing facility. Verification of the quantity of gas dissolved is essential.
- (2) Until greater accuracy is obtained, the equilibrium solubility values of He in MMH and NTO as cited in the Air Force Propellant Handbooks should be accepted as "standard." There are still enough uncertainties in the He saturation values to warrant further basic experimental studies.
- (3) The manometric measurement of gas volume from a frozen sample of propellant should be the accepted method for gas analysis.

Approved for public release;
distribution is unlimited

The studies described in this paper were carried out by the Jet Propulsion Laboratory, California Institute of Technology, under contract with the National Aeronautics and Space Administration. ✓

PRECEDING PAGE BLANK NOT FILMED

INTRODUCTION

The renewed interest in liquid bipropellant systems, pressurized directly by He has resulted in the expression of some concerns regarding the role of dissolved He. At JPL the Galileo and Mars Observer spacecraft both have He pressurized liquid propellant feed systems.

This paper details the studies performed by JPL to assure that the propellants used in the thruster qualification tests for the above programs had been satisfactorily saturated with He.

DISCUSSION

SATURATION TECHNIQUES

The rate of solution of a gas in a liquid is highly dependent upon the extent of agitation and mixing; gas diffusion through an immobile liquid can take months to equilibrate. The configuration of the propellant supply tanks at a test facility will determine the most efficient saturation technique for its system. JPL has had experience with several saturation techniques. Figures 1, 2 and 3 illustrate the saturation of liquids by aeration, bubbling and stirring. These mixing techniques combined with a systematic incremental pressurization with He until test pressure is achieved can provide satisfactorily saturated propellants. Depending upon the size of the run tanks, the saturation procedure may continue for several hours.

SAMPLING TECHNIQUES

Samples of propellant for gas analysis should be obtained at the pressure and temperature of the holding tanks. The best technique places the sampling cylinder as part of a pressurized, recirculating loop. However, many test systems cannot accommodate such a loop. A simpler technique is the filling of an evacuated sampling cylinder. If care is taken to allow time for redissolving of any He released during the propellant transfer this can be a satisfactory technique.

If the propellant samples are to be shipped to another location for analysis, each sample must be partially discharged into another evacuated cylinder. This satisfies the DOT mandate for an ullage in cylinders containing propellants.

REFERENCE VALUES FOR He SATURATION OF PROPELLANTS

The standard saturation values for He in liquid propellants are usually cited from the Air Force Propellant Handbooks (Ref. 1, 2). However, a search of other pertinent literature reveals some discrepancies.

MMH. The Propellant Handbook value (Ref. 2) for He saturated MMH (see Table I) is based entirely on the work of E. Chang of the Aerospace Corp. (Ref. 3, 4). Her tests were made at about one atmosphere of He pressure. This value, extrapolated to 250 psig (to reflect the conditions in various propulsion systems), is 0.21 cc STP*/g. An earlier study at the Marquardt Co. (Ref. 5) yields a value of 0.18 cc STP/g. However, tests at Aerojet General Corp. (Ref. 6, 7) in 1966 (and cited by I. Smith of WSTF in Ref. 8) produced a value of 0.13 cc STP/g. During saturation testing on the Viking propellants, JPL determined a value of 0.12 cc STP/g, and this value was used by Messerschmitt-Bolkow-Blohm (MBB) during their recent testing of the Galileo thrusters.

As noted in the Table II, actual values from recent testing by JPL and MBB lie mainly between the high and low numbers. These tests were done in support of Galileo thruster tests at MBB, Galileo alternate thruster tests and the Mars Observer thruster qualification program. These are single point measurements and considering the experimental conditions during the tests, it is not known if a true equilibrium was actually reached. Therefore, these numbers should not be used as "theoretical" saturation values.

NTO. The Propellant Handbook value (Ref. 2) for He saturation of NTO is derived from an unpublished study at Martin Marietta. This number, 0.32 cc STP/g at 250 psig and 25° C, agrees with those from WSTF (Ref. 9), TRW (Ref. 10) and the JPL Viking tests. The Marquardt Co. (Ref.

* STP = Standard Temperature and Pressure, 0° C and 760 mm Hg, (273 K and 101 kPa).

NTO (cont.)

5) and Aerospace Corp. (Ref. 3, 11) values are about 25% higher - 0.39 to 0.41 cc STP/g.

The saturation data cited above came from tests made at least 20 years ago. A critique of each data point would reveal weaknesses in the test techniques. The main weakness being the limitations of sensitivity in the pressure measuring devices. Modern manometer sensors have sensitivities of one to two orders of magnitude better than those used 20 years ago. Another major weakness is the sampling technique used to obtain the liquid propellant samples prior to gas analysis. The JPL Viking propellant samples were withdrawn from the storage tanks into sample cylinders pressurized with argon. This procedure allows He to escape from solution. The Handbook MMH value is almost double that found by JPL. However, the JPL NTO value agreed with the Handbook value.

The best sampling technique was used by WSTF, viz., the sampling cylinder was part of a pressurized, recirculating loop. Done correctly, this method should provide valid samples. However, their MMH value was 40% lower than the Handbook value.

The best overall technique for determining saturation value was used by E. Chang at Aerospace Corp. An accurately weighed propellant sample was placed in a container of accurately known volume. He gas was metered into the container, and the subsequent pressure drop was measured. Careful control of the temperature and stirring of the propellants insured uniformity during the many test cycles. For each propellant - NTO and MMH - this method yielded saturation values higher than those found in any of the other studies. However, these measurements were made at about one atmosphere of He pressure and it was necessary to use a linear extrapolation to actual propulsion test conditions.

EXPERIMENTAL

GALILEO

Saturation. Propellants for use in the Galileo alternate thruster program were stored in 30-40 gallon run tanks equipped with stirring paddles. The propellants had originally been stored in their original shipping containers under dry nitrogen pressure and contained considerable dissolved nitrogen. The propellants in the run tanks were "conditioned" prior to saturating by pressurizing with He to 450 psi and then blowing down to 20 psi. This cycle was repeated for ten times while stirring the propellants. Subsequent analysis indicated that most of the nitrogen had been blown off. Calculations (and later analysis) showed that the NO in the NTO is not seriously affected.

At this point, the stirred propellant was pressurized to 475 psi with He and held at this pressure for two hours at ambient temperature. The run tank pressure was reduced to 250 psi, and, after a half hour, the propellant was ready for sampling.

Sampling. Propellant samples were obtained by pressure filling into evacuated 150 cc stainless steel cylinders (see Figure 4). After allowing about 10-15 minutes for equilibration, the valve to the run tank was closed and the sampling cylinder opened into another evacuated cylinder. This step provided adequate ullage (necessary to comply with DOT regulations for shipment) without losing any of the dissolved gases. Each set of cylinders (sample and ullage) was shipped to JPL (as one sample). The cylinders were weighed before and after filling to determine the exact quantity of propellant sampled.

Gas Measurement. The apparatus for evolving and collecting the dissolved gases is shown in Figure 5. The propellant is introduced into the degassing tube and then frozen with LN₂. The evolved gases are pumped (using a mercury-filled toeppler pump) into an accurately known volume. The propellant is thawed to free any trapped gas and then refrozen with LN₂. This gas is also pumped into the measured volume.

The volume of evolved gas can then be calculated from the pressure and temperature in the measured volume. Gas samples are then withdrawn for analysis by mass spectrometry. As seen in Table II these values were very close to the measurements made by MBB in their tests of the 10N engine.

MARS OBSERVER

Saturation. Two sets of run tanks were used for propellant supply - small tanks of about 20 gallon capacity, and large tanks of 400 gal capacity. None were equipped with stirring paddles. In each case the He saturation of the MMH and NTO was accomplished by the stepwise addition of He gas through bubbles at the bottom of the tanks. To assure adequate exposure to the He and sufficient stirring for uniform mixing of the propellants, the He gas was added in increments of about 50 psig for 10 steps (with a 5-10 minute pause between steps) until a total pressure of 450 psig was obtained. This pressure was held for a minimum of two hours and then lowered to the test pressure of 250 psig.

Sampling. Samples were taken as before, except that they were not intended for shipment, and, were not divided between two sample cylinders. The contents of each cylinder was confirmed by weighing.

Gas Content. The volume of gas dissolved in the liquid propellant was measured as indicated above. The propellants in the small run tanks were easily saturated (see Table II). The large tank containing NTO oversaturated with He to about 140% of the Handbook value and required at least several days to equilibrate. The large tank containing MMH was difficult to saturate and a multiported bubbler was finally used to provide adequate agitation during the introduction of the He.

RECOMMENDATIONS FOR FURTHER STUDIES

Definitive Gas Solubility. The uncertainty in the equilibrium value for the solubility of He in MMH, and, to a lesser extent, in NTO warrants a thorough study to establish accurate values particularly at thruster test pressure and temperature. Extrapolation of low pressure values to 10-20 ATM may be valid, but experimental evidence at the higher pressures would be desirable. (See also Ref. 1)

Propellant Sampling Errors. No systematic study has been made of the errors inherent in the sampling of liquid propellants under high pressures. The testing done by JPL for GLL and Mars Observer were single point measurements, and it is not known if true equilibrium was actually attained in all of the tests. Duplicate samples generally yielded gas measurements within $\pm 10\%$. However, these duplicates were simultaneously obtained and can be considered as one sample divided into two. Sampling of propellants by filling evacuated cylinders is straightforward and convenient, but it is not known how consistent it is. Repetitive sampling of a single source of propellant would yield the information needed to establish the error limits.

REFERENCES

1. USAF Propellant Handbook, Hydrazine Fuels, Vol. 1, AFRPL-TR-69-149 (1970). Prepared by Bell Aerospace Textron.
2. USAF Propellant Handbook, Nitric Acid/Nitrogen Tetroxide Oxidizers, Vol. II, AFRPL-TR-76-76(1977). Prepared by Martin Marietta Corp.
3. E. T. Chang, et. al., "Solubilities of Gases in Simple and Complex Propellants," J. Spacecraft, 6 1177-1180 (1969).
4. E. T. Chang, et. al., "Thermodynamic Properties of Gases in Propellants II. Solubility of Helium, Nitrogen and Argon Gas in Hydrazine, Methylhydrazine, and Unsymmetrical Dimethylhydrazine," J. Phys. Chem 72, 638-642 (1968).
5. D. K. Fulkerson, "A Method for Saturating Propellants with Helium for Testing SSRCS Thruster," Marquardt Report no. TM05-A048 (1977) (An analysis of data originally presented in TMC Report No. ML2421, dated 1967).
6. Aerojet-General Corp., "Pressurization Systems Design Guide, Vol. IIB, Design Procedures and Data," Report No. 2736 (1966).
7. Aerojet-General Corp., "solubility of Helium and Nitrogen in Liquid Propellants," Report No. LM 0696-03-7 (1966).
8. I. D. Smith, "Determination of the Helium Saturation Level of Monomethylhydrazine and MON-3 Nitrogen Tetroxide," WSTF Document TR-244-001 (1979).
9. I. D. Smith, "Determination of Helium Saturation Level of Aerozine-50 and Nitrogen Tetroxide," NASA TN D-6249 (1971).
10. M. P. Gardner, et. al., "Study of Pressurant Gas Solubility in Nitrogen Tetroxide and Aerozine 50," TRW Report O1827-6205-RO-00 (1968).
11. E. T. Chang, "Thermodynamic Properties of Gases in Propellants and Oxidizers I. Solubilities of He, N₂, O₂, Ar, and N₂O₃ in Liquid N₂O₄," J. Phys. Chem. 70, 2394-2399 (1966).

Table I. Literature Values for Helium Solubility in Liquid Propellants Normalized to 25° C and 250 psig

	cc STP/g	Reference
<u>MMH</u>	0.21 ¹	Aerospace (3, 4) (Extrapolated value)
	0.21 ¹	Air Force Handbook (1)
	0.18	Marquardt (5)
	0.13 ²	WSTF (8)
	0.13 ²	Aerojet (6, 7)
	0.12	JPL Viking Tests
<u>NTO</u>	0.41	Aerospace (3, 11) (Extrapolated value)
	0.39	Marquardt (5)
	0.34	JPL Viking Tests
	0.33	WSTF (9)
	0.32	Air Force Handbook (2)
	0.32	TRW (10)

¹The MMH data in the Handbook is based entirely on the work of E. Chang at Aerospace Corp.

²The MMH data in the White Sands report was referenced as being derived from the earlier Aerojet report.

Table II. Helium Dissolved in Liquid Propellants at 25°C and 250 psig as Measured During Recent Saturation Tests for Galileo (GLL) and Mars Observer (MO) Programs

	cc STP/g	Reference
<u>MMH</u>	0.13-0.17 ¹	MBB/GLL
	0.15-0.17	JPL/GLL Alternate Thruster
	0.16-0.19 ²	JPL/MO large tank
	0.22-0.23	JPL/MO small run tanks
<u>NTO</u>	0.26-0.40 ¹	MBB/GLL
	0.31	JPL/GLL Alternate Thruster
	0.27-0.28 ³	JPL/MO large tank
	0.29-0.40	JPL/MO small run tanks

¹MBB data normalized to 25° C and 250 psig.

²Initial MMH saturation tests in the large tank indicated only 20-40% saturation.

³Initial NTO saturation tests in the large tank indicated 140% oversaturation.

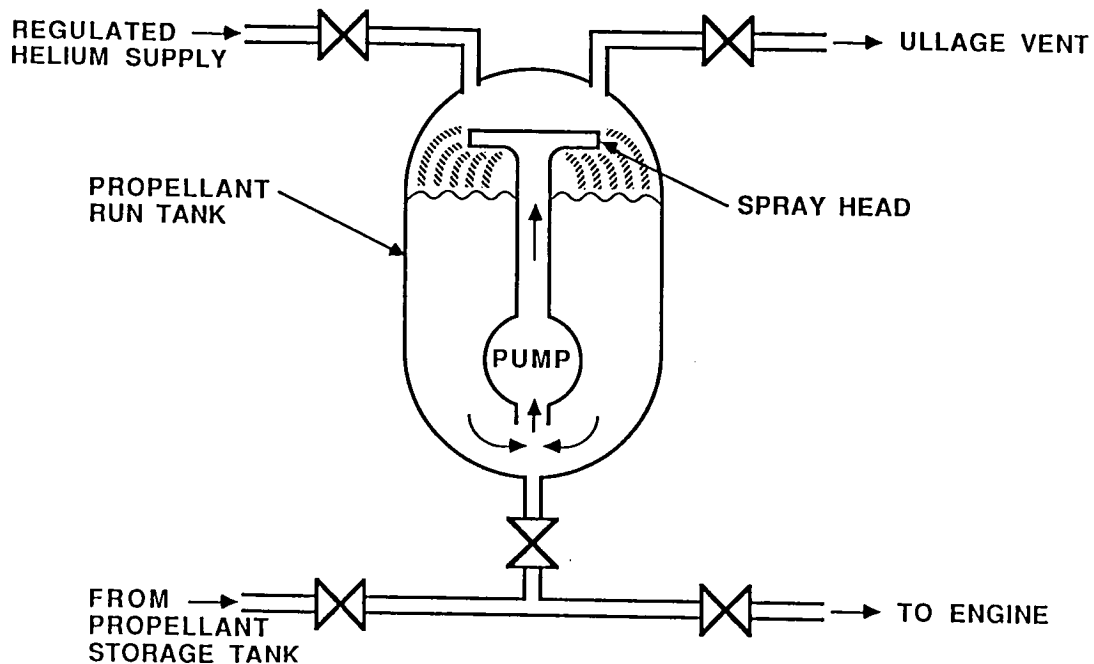

Figure 1. Gas Saturation of Liquids by Aeration

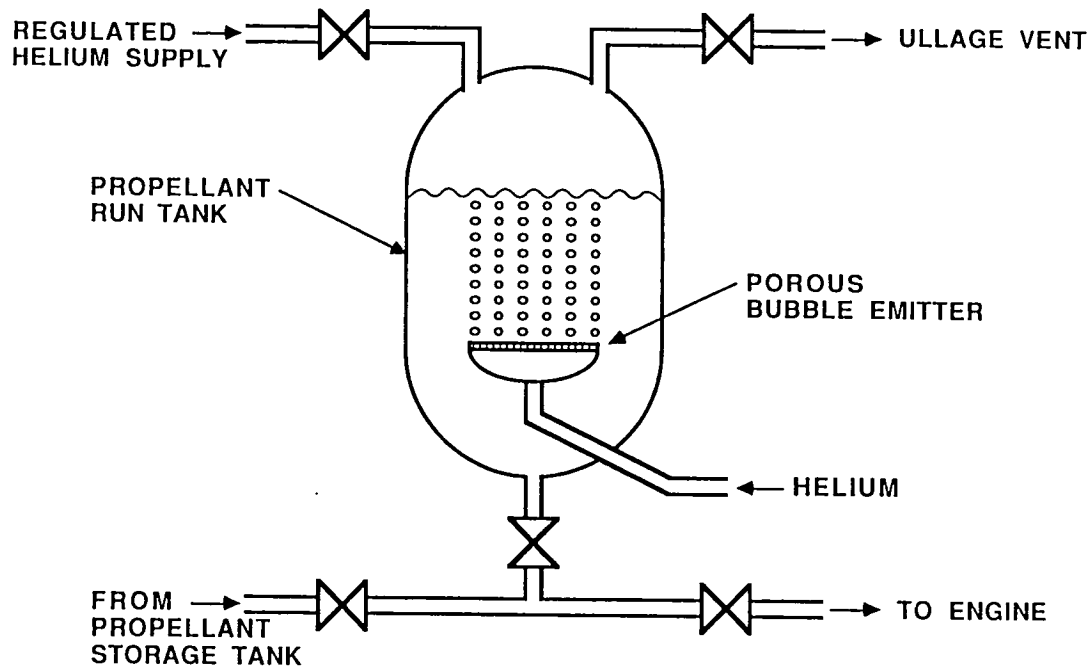

Figure 2. Gas Saturation of Liquids by Bubbling

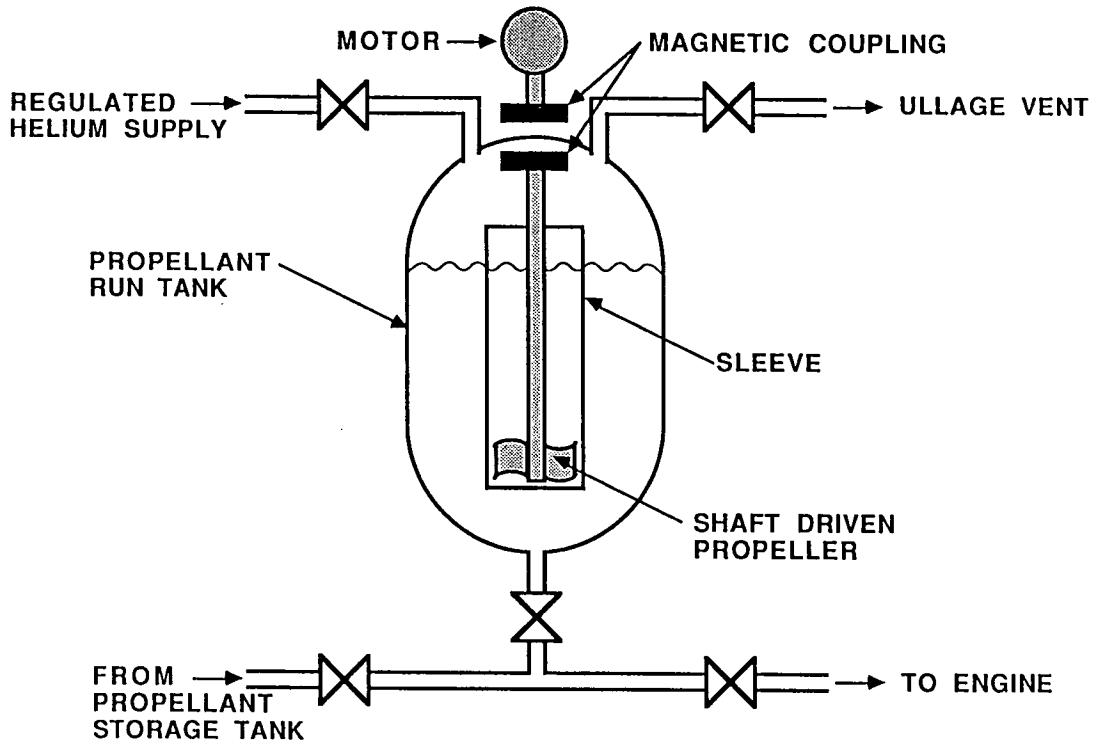

Figure 3. Gas Saturation of Liquids by Stirring

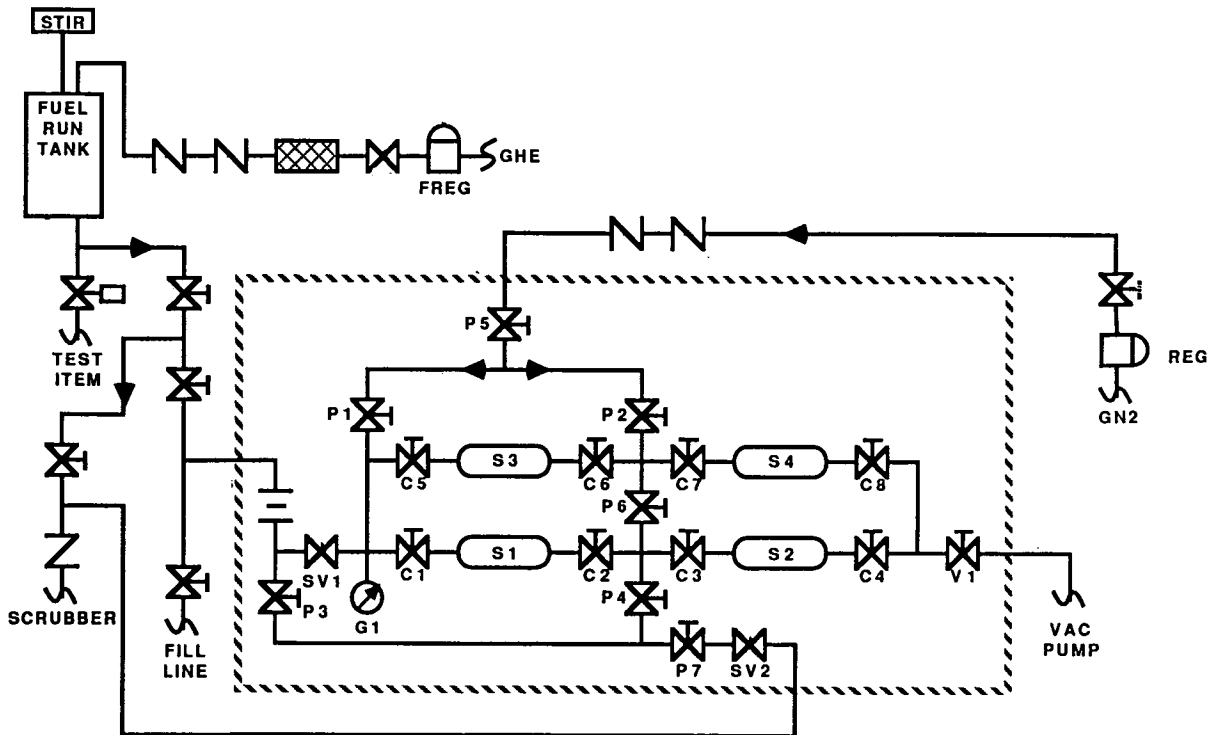

Figure 4. Apparatus Sampling of Propellant by Pressure Filling of Cylinders

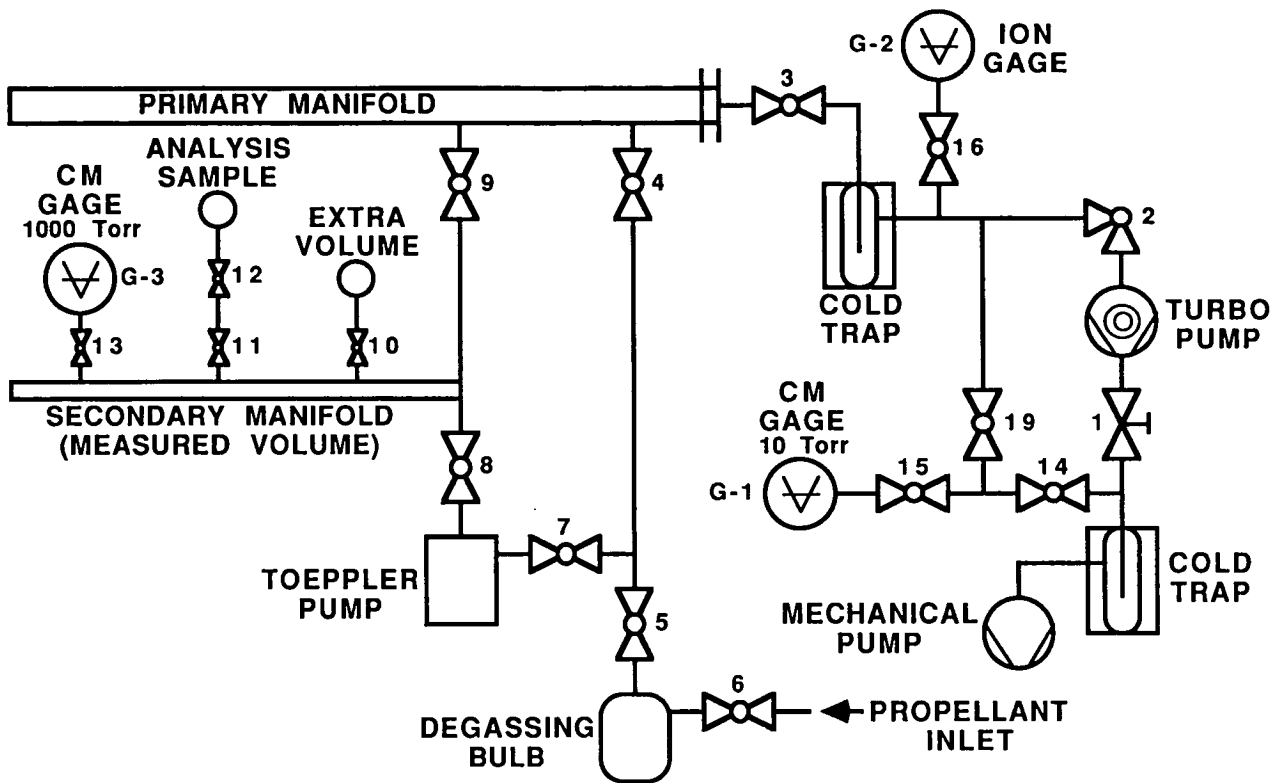

Figure 5. Apparatus for Evolving and Collecting Dissolved Gases