

47

N91-24380

14675

p.8

Processing of Glass-Ceramics from Lunar Resources

B. D. Fabes and W. H. Poisl

Department of Materials Science and Engineering

The University of Arizona

A/20

ABSTRACT

The goal of this project is to fabricate useful ceramic materials from the by-products of lunar oxygen production processes. Specifically, we are studying the crystal nucleation and growth kinetics of ilmenite-extracted lunar regolith, in order to produce glass-ceramics with optimal mechanical, thermal, and abrasion resistant properties. In the initial year of the program, we finished constructing and calibrating a high temperature viscometer, used for determining the viscosity of simulated lunar glasses. A series of lunar simulants were also prepared, and the viscosity of each was determined over a range of temperatures. We found that an increase in the concentration of Fe_2O_3 decreases the viscosity of the glass. While this may be helpful in processing the glass, Fe_2O_3 concentrations greater than approximately 10 wt % resulted in uncontrolled crystallization during viscosity measurements. Impurities (such as Na_2O , MnO , and K_2O) in the regolith appeared to decrease the viscosity of the parent glass. These effects, as well as those of TiO_2 and SiO_2 on the processability of the glass, however, remain to be quantified.

I. INTRODUCTION

Many processes proposed for obtaining oxygen from the lunar regolith are based on reducing ilmenite. Ilmenite, however, is present in the regolith at a concentration of only about 10 wt %. In order for any oxygen production scheme to be efficient, the ilmenite must be concentrated before it is reduced. This will produce a large amount of ilmenite-extracted regolith, which has many potential uses. We are examining the production of ceramic materials from these by-products.

In general, two approaches can be taken to examining the usefulness of ilmenite-extracted regolith. One might process the regolith using a multitude of heating and cooling schedules, and then test the properties of the resulting material. Or, one might study the effect of composition and heating on the development of microstructure in the ceramic material and, based on this knowledge, engineer materials with specific microstructures and, hence, properties, to meet specific needs. We are taking the latter approach, as a generic route to producing glass-ceramics from the by-products.

Glass-ceramics are polycrystalline materials produced by the carefully controlled crystallization of a glass. In the production of a glass-ceramic, a melt is cooled rapidly to avoid

crystallization, resulting in a homogeneous glass. The glass is heated to nucleate small crystallites, which are then grown at a slightly higher temperature. After crystallization, a typical glass-ceramic contains from 1 to 10 vol % residual glass.

The properties of a glass-ceramic depend strongly on controlling the size, shape, composition, and distribution of the crystal and glass phases. When properly controlled, extremely strong, abrasion resistant, highly refractory materials can be produced. In addition to these desirable properties, glass-ceramics are based on standard glass forming processes, which lend themselves to easy formation of complex shapes and components.

The nucleation and growth rates of the crystallites in glass-ceramics are extremely sensitive to the viscosity of the glass, which depends on both temperature and composition. Therefore, in order to control the crystallization process of the glass, the effect of composition on viscosity must be understood. In the first phase of our research, we are investigating the effects of composition on the viscosity of lunar glasses. This will allow us to determine ranges of compositions which are robust with respect to variations of feedstock on the final microstructure and, hence, properties of the glass-ceramic. In the second phase of this research we will examine the microstructure and properties of glass-ceramics produced using simulated lunar glasses. Finally, we will combine our understanding of the effects of composition on the development of microstructure with our understanding of the effects of microstructure on properties to prepare glass-ceramics with tailored mechanical, thermal, and abrasion resistant properties.

During the past year we began the first phase of this research. We finished constructing and calibrating an apparatus for determining high temperature viscosity of small glass samples. A series of lunar regolith simulants was prepared, and the viscosities of the different simulants were measured using this instrument. The effects of Fe_2O_3 , TiO_2 , and minor impurities on the viscosity were investigated.

II. VISCOMETER

A schematic drawing of the viscometer is shown in Figure 1. Viscosity is measured using a three point bending scheme. First, samples measuring approximately 2.6 x 0.5 X 0.4 cm are cut from prepared glass blocks. The samples are then placed in a fused silica holder and introduced into a furnace assembly which is preheated to the temperature of interest. An LVDT measures the deflection rate at the midpoint of the sample. A typical deflection versus time curve is shown in Figure 2. Assuming that the glass behaves as a newtonian fluid, the deflection should be a linear function of time, as demonstrated in Figure 2. The viscosity is then calculated from the slope of this line. This process is then repeated at each temperature of interest for each sample, so that the change in viscosity with temperature can be determined.

III. VISCOSITY OF LUNAR GLASSES

Glass blocks were prepared by melting both reagent grade oxides and terrestrial simulants in air at temperatures between 1500 and 1600 °C. The melts were cast into a 6 cm diameter water-cooled copper mold to form glass blocks. The thickness of the glass blocks ranged from 2 to 4 cm, depending primarily on the quantity of glass melted. (Crystallization was never observed during this process.) The compositions investigated are shown in Table 1. Samples A12 and A17, prepared from reagent grade oxides, approximate the average compositions of the lunar regolith at the Apollo 12 and 17 sites, respectively, with all the ilmenite extracted, and without any minor impurities. Samples B12 and B17 were similar to the A12 and A17 compositions, except that the concentration of Fe_2O_3 was reduced even further. For all of these reagent grade samples, approximately 5 wt % TiO_2 was added, since rutile is used as a nucleating agent during the glass-ceramic process. The MLS-2 and MLS-3 samples were prepared from Minnesota Lunar Simulant.* MLS-3 contained ilmenite, while MLS-2 had the ilmenite electrostatically separated.

The variation of viscosity with temperature for each composition is shown in Figure 3. From Figure 3 it can be seen that the viscosity decreases as the iron content increases (samples B17, B12 and A17). This result is not surprising, since iron is an effective fluxing agent for silicate glasses. For processing of glass-ceramics, a reduction in viscosity will decrease the maximum temperature required for effective working of the glass, as well as increase the working range of the glass.

Comparing the viscosities and compositions of MLS-2 and A17 (ilmenite-extracted terrestrial and ilmenite-extracted oxide simulants) we see that MLS-2 has a lower viscosity at all temperatures than A17. They both have similar iron contents, but the SiO_2 content is somewhat higher in MLS-2. The addition of SiO_2 (a glass former) should increase the viscosity of the glass, but this is not seen. Hence, the differences between these compositions must be due either to the smaller concentration of TiO_2 content or to the impurities in the MLS-2 sample. Most of the impurities are glass modifiers, and should decrease the viscosity of the glass. The role of TiO_2 has not yet been determined, but may also account for the difference in the viscosity between the samples. It is known that TiO_2 can enter a glass as either a network former or modifier. Hence, this is an area which must be explored further.

From the above results we would expect that the MLS-3 and A12 samples (those with high concentrations of Fe_2O_3) would have a low viscosity due to the Fe_2O_3 . However, they appear to have higher viscosities than any other samples. This is probably due to crystallization of

* P.W. Weiblen and K.L. Gordon, "Characteristics of a Simulant For Lunar Surface Materials," in Lunar Bases and Space Activities in the 21st Century, LPI, Houston TX, 1988.

the samples during the measurements. This was suggested by a nonlinear deflection rate during viscosity measurements (the viscosity which is reported here was obtained from the initial deflection rate at each temperature) and by observation of crystalline-like striae in the samples after removal from the furnace. In fact, Fe_2O_3 has been reported to be an effective nucleating agent for silicate glasses at high concentrations* .

It is interesting that the apparent activation energies for deformation, as given by the slope of the $\log(\eta)$ vs. $1/T$ curves in Figure 3, are different for the two samples which appeared to crystallize. We do not understand the implications of this difference, although it is a clear indication of the pivotal role that iron oxides will play in forming glass-ceramics. Finally, we must keep in mind that the effect of ferrous vs. ferric iron has not yet been examined. The oxidation state of the iron has been shown to effect the viscosity of anorthitic glass-ceramics[§] and therefore is likely to have an effect on the processing of lunar glass-ceramics.

IV. CONCLUSIONS

For Fe_2O_3 concentrations less than 10 wt %, increasing concentrations of iron result in a decrease in the viscosity of lunar glasses. Microstructural effects aside, this decrease in viscosity should improve the processability of glass-ceramics. However, in order to control the crystallization process, the concentration of iron must be kept below approximately 10 wt %, since crystallization occurs readily above this concentration. Increasing concentration of TiO_2 appears to increase the viscosity at any given temperature, although this effect may also be due to the minor impurities in the regolith.

V. FUTURE WORK

To complete this first phase of the research, the effect of TiO_2 , SiO_2 , and minor impurities on viscosity must be quantified, and the upper limit of iron content needs to be more firmly established. In addition, the ratio of ferric to ferrous iron, which has been shown to effect viscosity, must be considered and controlled. Based on these results the second phase of this research – studying the kinetics of crystallization and microstructural development and the effects of microstructure on mechanical properties – can begin.

* M. Cukiermann et al, "Viscous Flow and Crystallization Behavior of Selected Lunar Compositions," in Proceedings of the Fourth Lunar Science Conference, (1973) pp. 2685-2696.

§J. Williamson, A.J. Tipple, and P.S. Rogers, "Influence of Iron Oxides on Kinetics of Crystal Growth in $\text{CaO-MgO-Al}_2\text{O}_3\text{-SiO}_2$ Glasses," *Journal of the Iron and Steel Institute*, (1968) 898-903.

Table 1: Chemical Compositions of Melts (wt %)

	A12	A17	B12	B17	MLS2 [§]	MLS3 [§]
SiO ₂	46.7	46.8	50.2	49.4	54.0	43.9
Al ₂ O ₃	13.6	14.65	14.6	15.45	14.6	13.7
Fe ₂ O ₃ [*]	14.4	9.9	8.0	5.0	9.3	16.1
CaO	10.5	12.6	11.35	12.3	13.4	10.1
MgO	9.8	11.0	10.5	11.6	7.6	6.8
TiO ₂	5.0	5.0	5.37	5.3	0.9	6.32

[§] Only major constituents reported

* All Fe assumed to be in the form of Fe₂O₃

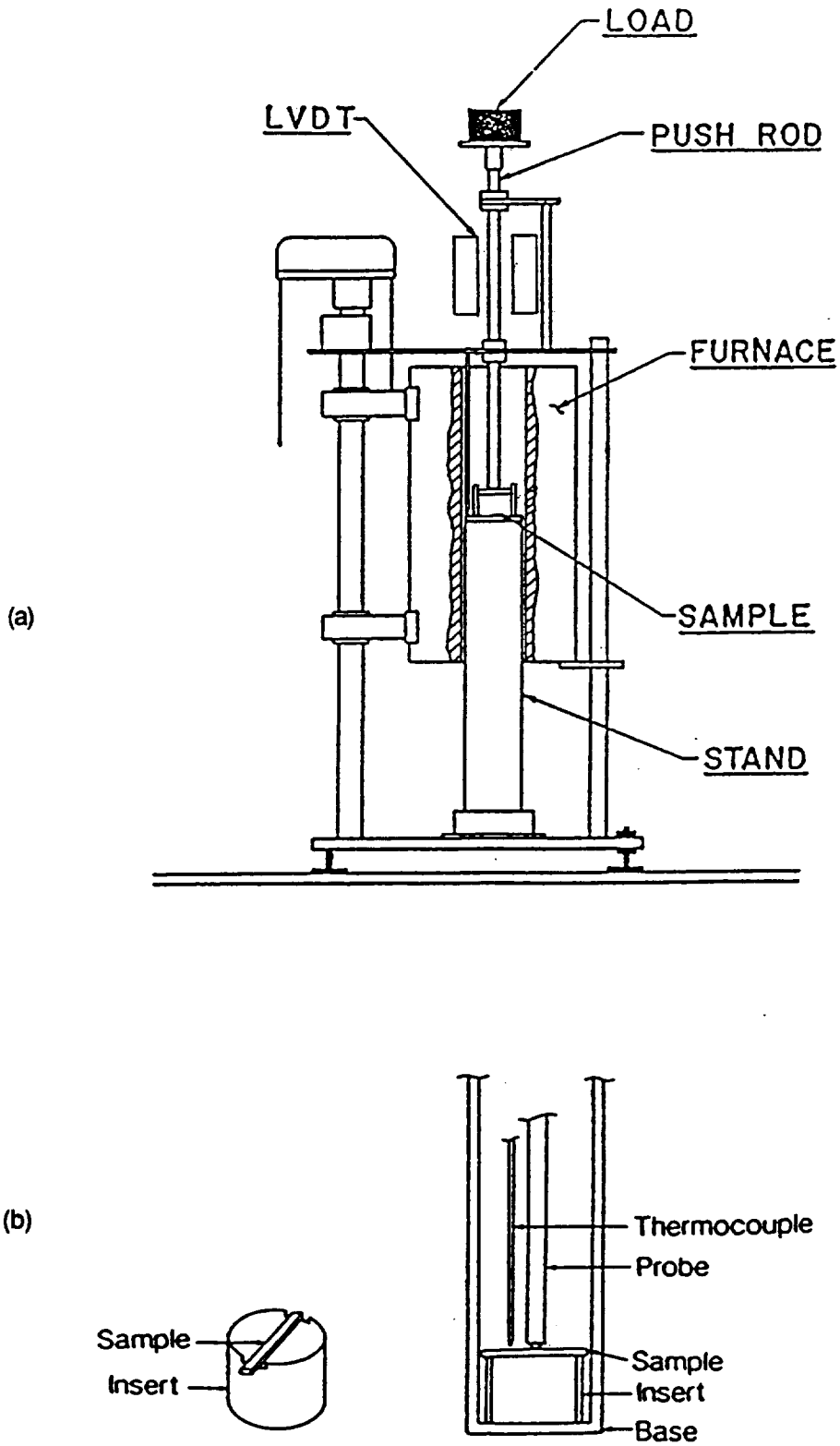

Figure 1: (a) Schematic diagram of viscometer, showing the positioning of the LVDT, pushrod, and sample assembly. (b) Fused silica insert with sample and probe assembly.

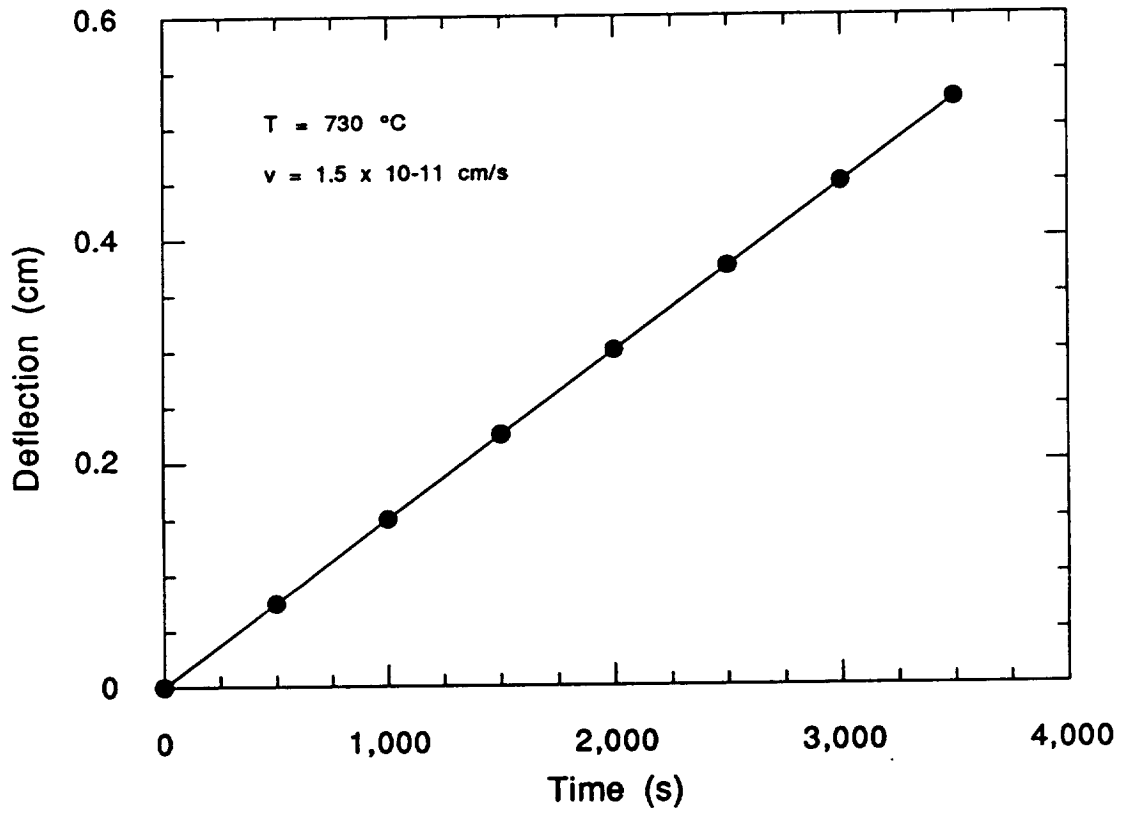

Figure 2: Typical deflection vs. time curve for a simulated lunar glass at 730 °C. Solid line represents a least squares linear fit of the data.

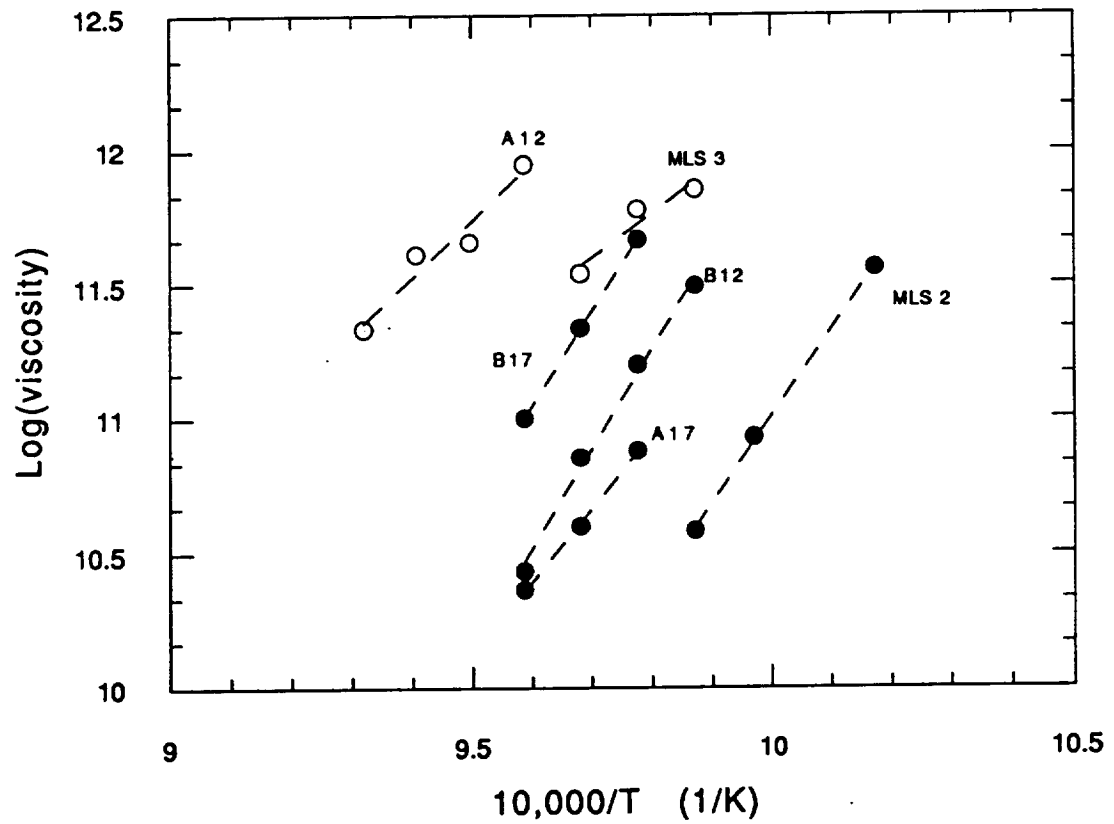

Figure 3: Variation of viscosity with temperature for simulated lunar glasses. Dashed lines are least squares, linear fits.