

4-93

NASA Contractor Report 177527

# Tailorable Advanced Blanket Insulation Using Aluminoborosilicate and Alumina Batting

Dominic P. Calamito

(NASA-CR-177527) TAILORABLE ADVANCED  
BLANKET INSULATION USING ALUMINOBOROSILICATE  
AND ALUMINA BATTING (Woven Structures)  
93 p

CSCCL 11C

N91-24452

Unclas

G3/27

0019900

CONTRACT NAS2-12693

July 1989

Date for general release July 1991.



National Aeronautics and  
Space Administration



# Tailorable Advanced Blanket Insulation Using Aluminoborosilicate and Alumina Batting

Dominic P. Calamito  
Woven Structures Division of HITCO, Compton, California

Prepared for  
Ames Research Center  
CONTRACT NAS2-12693  
July 1989

Date for general release July 1991.



National Aeronautics and  
Space Administration

Ames Research Center  
Moffett Field, California 94035



TABLE OF CONTENTS

<u>Section</u>		<u>Page No.</u>
1.0	INTRODUCTION & BACKGROUND.....	1
2.0	TECHNICAL PROGRAM, ITEMS 1 & 2.....	1
2.1	OBJECTIVES, ITEMS 1 & 2.....	1
2.2	PROGRAM PLAN, ITEMS 1 & 2.....	5
3.0	TECHNICAL PROGRAM, ITEMS 3, 4 & 5.....	29
3.1	OBJECTIVES, ITEMS 3, 4 & 5.....	29
3.2	PROGRAM PLAN, ITEMS 3, 4 & 5.....	37
4.0	HEALTH & SAFETY.....	48
5.0	SUMMARY & CONCLUSIONS.....	48
6.0	RECOMMENDATIONS.....	52
7.0	LIST OF APPENDICES.....	53

## LIST OF ILLUSTRATIONS

<u>Figure</u>		<u>Page No.</u>
1-1	Woven Fluted Core Configurations Used in Previous NASA Development Programs.....	2
1-2	Schematic View of TABI Concept for an Inflatable Ballute.....	3
1-3	Two-Gore TABI Assembly Fabricated Into Spherical Shape.....	4
2-1	Program Plan for Items 1 and 2.....	7
2-2	Yarn Arrangement of Fluted Core Fabric for Items 1 and 2.....	8
2-3	Check-Mandrel Dimensions.....	9
2-4	Schematic View of Loom Set-Up.....	11
2-5	Stripped Rayon Serving.....	12
2-6	New Position of Hold Down Bar.....	13
2-7	Cross Sections of Ultrafiber Mandrels Before and After Heat Cleaning.....	16
2-8	Ultrafiber-Insulated Fluted Core Sample After Heat Cleaning.....	17
2-9	Ultrafiber Panel As-Received.....	18
2-10	Close-up of Ultrafiber Panel Showing Scrim and Stitching.....	19
2-11	Broken Stitches in As-Received Ultrafiber Panel.....	20
2-12	Rigidized Ultrafiber Panel.....	22
2-13	Insulation Mandrel Cut from Ultrafiber Panel.....	23
2-14	Cross Section of Ultrafiber Mandrel.....	24
2-15	Ultrafiber Mandrel and Flute Cross Sections.....	25
2-16	Mandrel Insertion Tool.....	26
2-17	Fluted Fabric Being Insulated Using Insertion Tool.....	27
2-18	Cross Sections of Saffil Mandrels Before and After Heat Cleaning.....	30

2-19	Saffil-Insulated SiC TABI Sample After Heat Cleaning.....	31
2-20	Saffil Panel As-Received.....	32
2-21	Saffil Mandrel and Flute Cross Sections.....	34
2-22	Insulation Mandrel Cut from Saffil Panel.....	35
3-1	Program Plan for Items 3, 4 and 5.....	39
3-2	Creel Set-up for Nextel TABI.....	40
3-3	Nextel 440 Warp Entering Back of Loom.....	41
3-4	Nextel 440 TABI Fabric Showing Crimped Ribs.....	43
3-5	Nextel 440 TABI Fabric Showing Sheared Ribs.....	44
3-6	Large Diameter Idler Roll.....	45
3-7	Nextel 440 TABI Fabric with Vinyl Tube Inserts.....	46
3-8	Nextel 440 TABI Fabric Woven with Vinyl Inserts.....	47
3-9	Nextel 440 TABI Cross Section Insulated with Saffil.....	49
3-10	Heat Cleaned Nextel 440 TABI Panel Insulated with Saffil.....	50

## LIST OF TABLES

<u>Table</u>		<u>Page No.</u>
2-1	Target Characteristics and Dimensions of Items 1 and 2 SiC TABI Fabrics.....	6
2-2	Physical Characteristics of Stitchbonded Ultrafiber Felt Sample.....	15
2-3	Physical Characteristics of Saffil Alumina Insulation Board Samples.....	28
2-4	Analysis of Discolored Saffil Panels.....	33
2-5	Actual Characteristics and Dimensions of Items 1 and 2 SiC TABI Fabrics.....	36
3-1	Target Characteristics and Dimensions of Items 3, 4, and 5 SiC TABI Fabrics.....	38
3-2	Actual Characteristics and Dimensions of Items 4 and 5 Nextel 440 TABI Fabrics.....	51



## PREFACE

This report was prepared by the Woven Structures division of HITCO, Compton, California, under NASA Contract NAS2-12693. The program was administered by the NASA-Ames Research Center, Moffett Field, California, with Mr. P. M. Sawko serving as the NASA Technical Monitor.

Mr. R. H. Pusch served as Woven Structures' Program Manager, assisted by Mr. Dominic P. Calamito, Project Engineer.

The report covers work performed during the period September 1987 to September 1988 and was submitted by the author in September 1988.

Use of trade names or names of manufacturers in this report does not constitute an official endorsement of such products or manufacturers, either expressed or implied, by the National Aeronautics and Space Administration.

## 1.0 INTRODUCTION AND BACKGROUND

- 1.1 As part of NASA's program to develop improved insulation materials for future space transportation systems, work has progressed on a concept using a woven fluted core fabric that has the flutes filled with fibrous insulation. This integrally woven material consists of parallel fabric faces connected to each other by fabric ribs that may be designed to a variety of flute cross sections. Variations of fluted core constructions used in some of the previous efforts included rectangular and triangular configurations, as well as configurations having two layers of flutes between the outer faces, Figure 1-1. These fabrics have been woven from relatively fragile, high temperature yarns including Astroquartz<sup>TM</sup>, Nextel<sup>TM</sup>, Nicalon<sup>TM</sup>, and combinations of these. Insulation in the flutes has, for the most part, been Q-Fiber Felt<sup>TM</sup>. FRCI 20-12 Type 3 refractory material as supplied by NASA has also been used.
- 1.2 The prime attractiveness of this concept has been the integral bond between the two fabric faces assuring containment of the insulation material when the system is subjected to service temperatures and loads. The fluted core fabric also has sufficient flexibility to conform to geometric contours, and can be tailored to meet thermal and mechanical design requirements by varying flute size, fabric raw materials, and insulation fillers.
- 1.3 Use of this Tailorable Advanced Blanket Insulation (TABI) as thermal protection for Orbital Transfer Vehicles (OTV) appears promising. One concept is to incorporate TABI in a ballute system which consists of a fixed heat shield nose connected to an expandable or inflatable structure as illustrated in Figure 1-2. The structure, made from a number of TABI gores joined together, would be stowed in as compact a volume as possible, and on command, be deployed to its final shape. Each gore of the structure would have the TABI facing the environment's hot side with the integrally woven single ply fabric on the inflated ballute's cold side, as depicted in Figure 1-2.
- 1.4 On a recent NASA program (NAS2-12253), a two-gore assembly was fabricated from insulation-filled fluted core fabric into a large spherical shape, as shown in Figure 1-3. Although further development is required, the success of that program demonstrated that the TABI concept may be useful for certain types of space insulation requirements.
- 1.5 To further develop and explore TABI materials for these advanced applications, a contract (NAS2-12693) was awarded in September 1987 to Woven Structures. This program was to produce TABI blanket materials based on two variations of woven fluted core fabrics. The first fabric was to be woven entirely from Nicalon silicon carbide yarns, a portion of which was to be filled with Nextel 440 aluminoborosilicate (ABS) Ultrafiber<sup>TM</sup> batting, and the balance filled with Saffil<sup>TM</sup> alumina batting. The second fabric was to be woven from Nextel low-boria aluminoborosilicate 440 yarn, portions of which were to be filled with Saffil and ABS batting, and the remainder to be delivered without insulation. This report covers the work accomplished during the course of the contract.

## 2.0 TECHNICAL PROGRAM, Items 1 and 2

### 2.1 Objectives

---

<sup>TM</sup> Astroquartz is a registered trade mark of J. P. Stevens Co.

<sup>TM</sup> Nextel is a registered trade mark of the 3M Co.

<sup>TM</sup> Nicalon is a registered trade mark of Nippon Carbon, Ltd.

<sup>TM</sup> Q-Fiber Felt is a registered trade mark of the Manville Co.

<sup>TM</sup> Ultrafiber is a trademark of the 3M Co.

<sup>TM</sup> Saffil is a registered trademark of ICI Ltd.

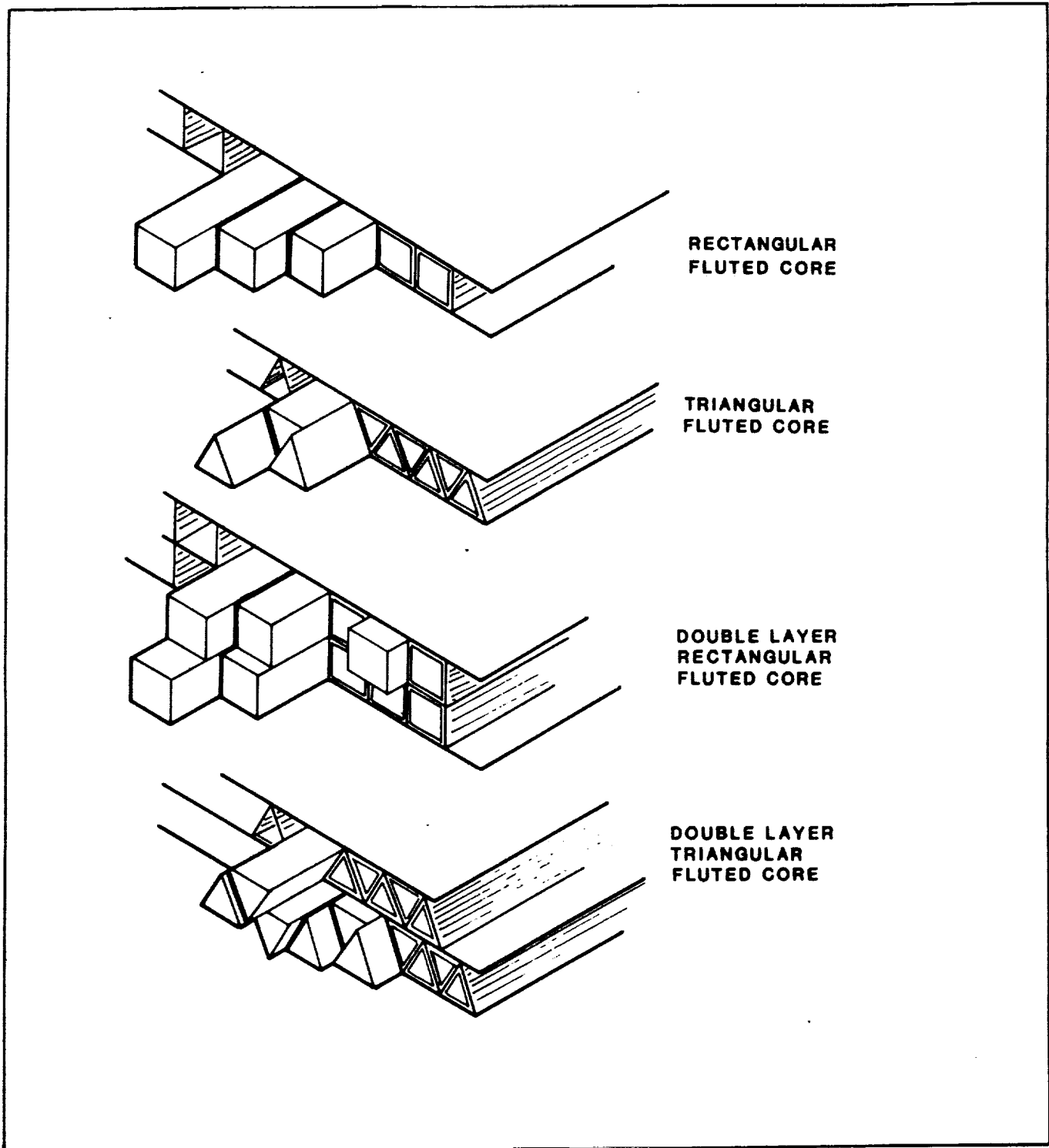

**Figure 1-1**  
**WOVEN FLUTED CORE CONFIGURATIONS USED IN PREVIOUS**  
**TABI DEVELOPMENT PROGRAMS. INSULATION MANDRELS ARE**  
**SHOWN PARTIALLY INSERTED INTO FLUTES.**

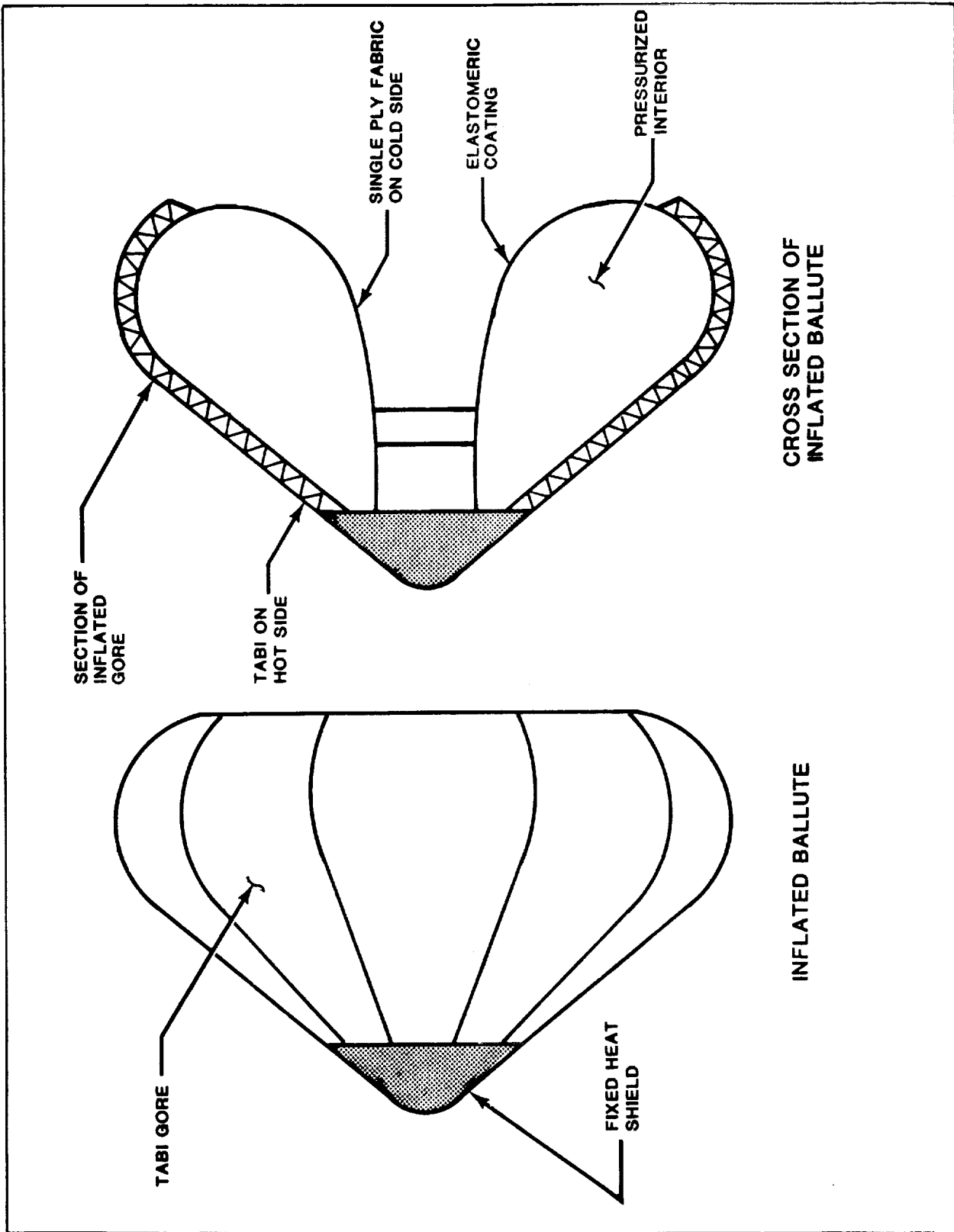

Figure 1-2  
 SCHEMATIC VIEW OF TABI CONCEPT FOR AN INFLATABLE BALLUTE



Figure 1-2

TWO-GORE TABI ASSEMBLY FABRICATED INTO  
SPHERICAL SHAPE

- 2.1.1 Nine lineal meters (10 yards) of triangular cross section fluted core fabric 0.66 meters (26 in.) wide, were to be woven from Nicalon silicon carbide yarn into 1.27 cm (0.50 in.) cell height fluted core fabric. To produce Item 1, the flutes in half of this material were to be filled with 3.57 kg/cubic meter (6 lb./cubic feet) stitch-bonded aluminoborosilicate (ABS) batting Ultrafiber 440. The remainder of the SiC fluted fabric, Item 2, was to be filled with 3.57 kg/cubic meter (6 lb./cubic feet) alumina batting, Saffil. Four panels of each type of insulated fabric were to be supplied, 3 being 122 cm (4 feet) long and 1, 91 cm (3 feet) long. The target characteristics and dimensions of the material established by NASA are shown in Table 2-1.
- 2.1.2 No major problems were anticipated in producing the fluted core fabric since similar Nicalon fabrics were successfully woven and converted to TABI panels on previously completed NASA contracts. However, little or no previous working experience with the Ultrafiber and Saffil insulations made it difficult to predict their processing abilities.
- 2.2 Program Plan. The flow chart in Figure 2-1 defines the tasks required to produce the Nicalon TABI panels of Saffil and Ultrafiber insulations. The discussion that follows describes the effort involved in performing these tasks including the fabric design considerations, processing difficulties, and the solutions to these problems.
- 2.2.1 Fabric Design and Programming. Producing a single-layer woven fluted core for this effort requires the weaving of three fabrics simultaneously, a top face, rib, and bottom face. Each fabric requires its own design and warp yarn system, and the overall design must be coordinated so that the warp yarns of the rib fabric interlock properly at the nodes formed with the face fabrics. The design of the fluted fabric depends primarily upon the desired flute (or cell) height, the desired individual face and rib fabric thicknesses, and types of yarns. Other considerations include selecting a style of weave for each fabric, which is in turn influenced by the end application requirements of the fluted core and by the properties of the yarns. The design task for this program involved schematically arranging the placement of every warp and fill yarn for each fabric to produce the desired construction and flute dimensions. The loom programming involved the design and arrangement of the loom's control device to provide the proper sequencing of shed openings (raising and lowering of predetermined warp yarns) for each fill yarn (pick) insertion.
- 2.2.1.1 A plain weave fabric designed for a previous NASA effort to produce 1.27 cm (0.5 in.) flute height fabric was utilized for weaving the Item 1 and 2 fabrics. A schematic of this design including the weave pattern at the nodes is presented in Figure 2-2. This locking arrangement at the nodes was selected after evaluating three other designs and used successfully for these fragile yarns in the prior program.
- 2.2.1.2 Also, as part of the design task, the yarn placement on the creels, the loom modifications and the loom set up requirements, including tensioning of the warp yarns, and the draw-in sequence of these yarns were determined. Fixtures were available from previous programs, including triangular cross section wood mandrels for inspecting the cell sizes of the flutes. The dimensions for these check mandrels are presented in Figure 2-3.
- 2.2.2 Yarn Procurement and Preparation. Nicalon (silicon carbide) yarn was procured and prepared for weaving. This yarn, designated as NLP-201, flexible grade, was ordered with a "P" type, or epoxy compatible sizing. The product, according to literature information, is a single ply tow material composed of 500 round cross section continuous filaments having a range of diameters from 10 to 20 microns ( $39.37 \times 10^{-5}$  to  $78.74 \times 10^{-5}$  in.). Its yield count is listed as 200 tex, (200 gms./1000 meters), which corresponds to 1800 denier, (1800 grams/9000 meters) or 2480 yards per pound. Past experience indicated that this yield value was overstated approximately 10% partly due to the sizing and possibly a greater number of filaments falling in the higher end of the filament

Table 2-1

TARGET CHARACTERISTICS AND DIMENSIONS  
OF ITEMS 1 AND 2 SIC TABI FABRICS

FABRIC YARN COUNT	TARGET VALUES	
	ITEM 1	ITEM 2
TOP FACE (WARP X FILL)		
ENDS/cm X PICKS/cm	6.4 X 9.5	6.4 X 9.5
ENDS/inch X PICKS/inch	16.0 X 24.0	16.0 X 24.0
RIBS		
ENDS/cm X PICKS/cm	6.4 X 7.1	6.4 X 9.5
ENDS/inch X PICKS/inch	16.0 X 18.0	16.0 X 18.0
BOTTOM FACE		
ENDS/cm X PICKS/cm	6.4 X 9.5	6.4 X 9.5
ENDS/inch X PICKS/inch	16.0 X 24.0	16.0 X 24.0
FABRIC AREAL WEIGHT		
kgs./sq. meter	1.17	1.17
oz./sq. yard	34.40	34.40
PANEL AREAL WEIGHT (INCLUDING INSULATION)		
kgs./sq. meter	2.39	2.39
oz./sq. yard	70.40	70.40
FABRIC FACE THICKNESS		
TOP FACE		
cm	0.041	0.041
inch	0.016	0.016
BOTTOM FACE		
cm	0.041	0.041
inch	0.016	0.016
FLUTE HEIGHT (OR CELL HEIGHT)		
cm	1.27	1.27
inch	0.50	0.50
GROUND WIDTH		
cm	66.04	66.04
inch	26.00	26.00
EACH SELVAGE (TOP AND BOTTOM FACE)		
cm	2.54	2.54
inch	1.00	1.00

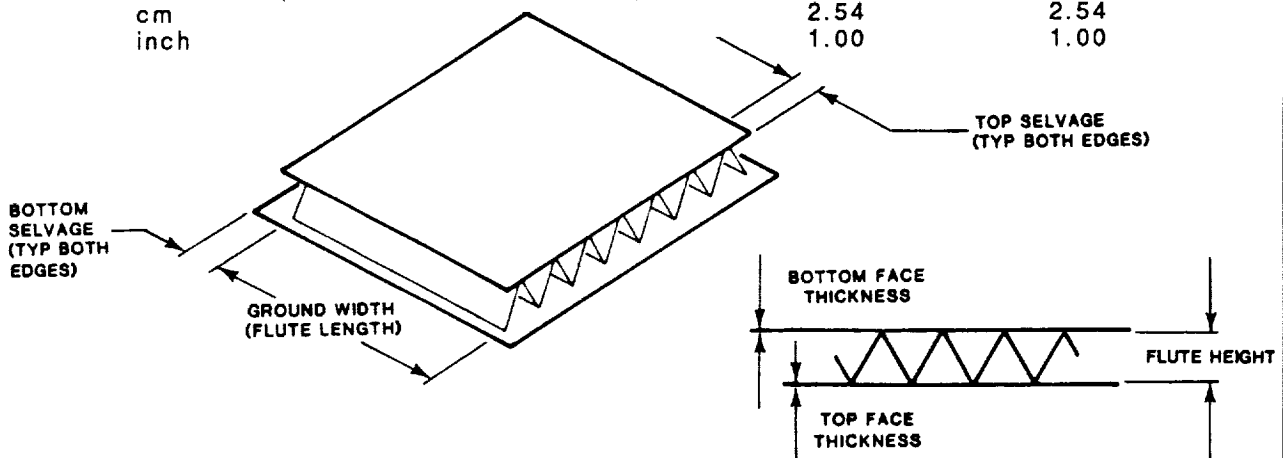



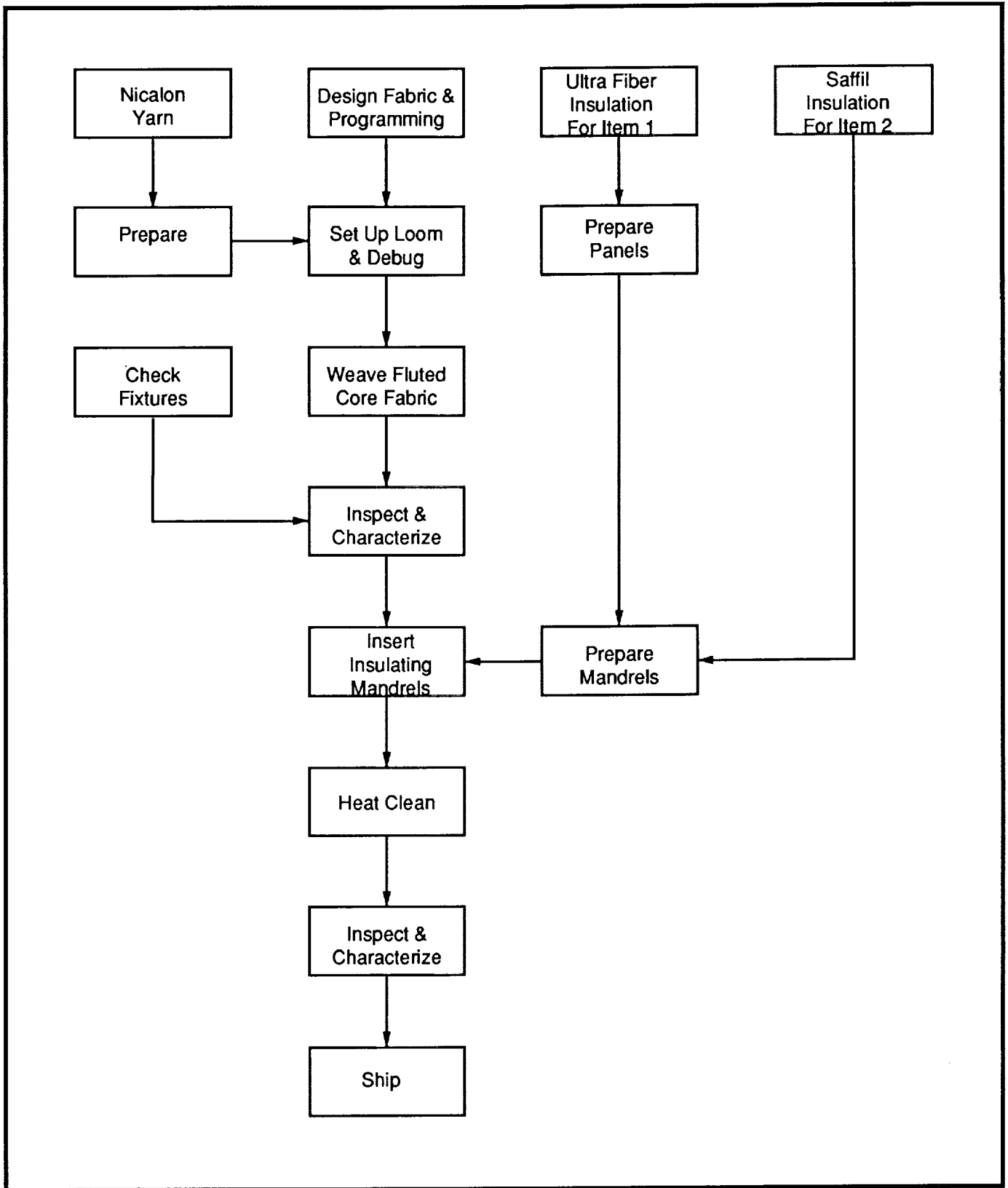

Figure 2-1

PROGRAM PLAN, ITEMS 1 AND 2

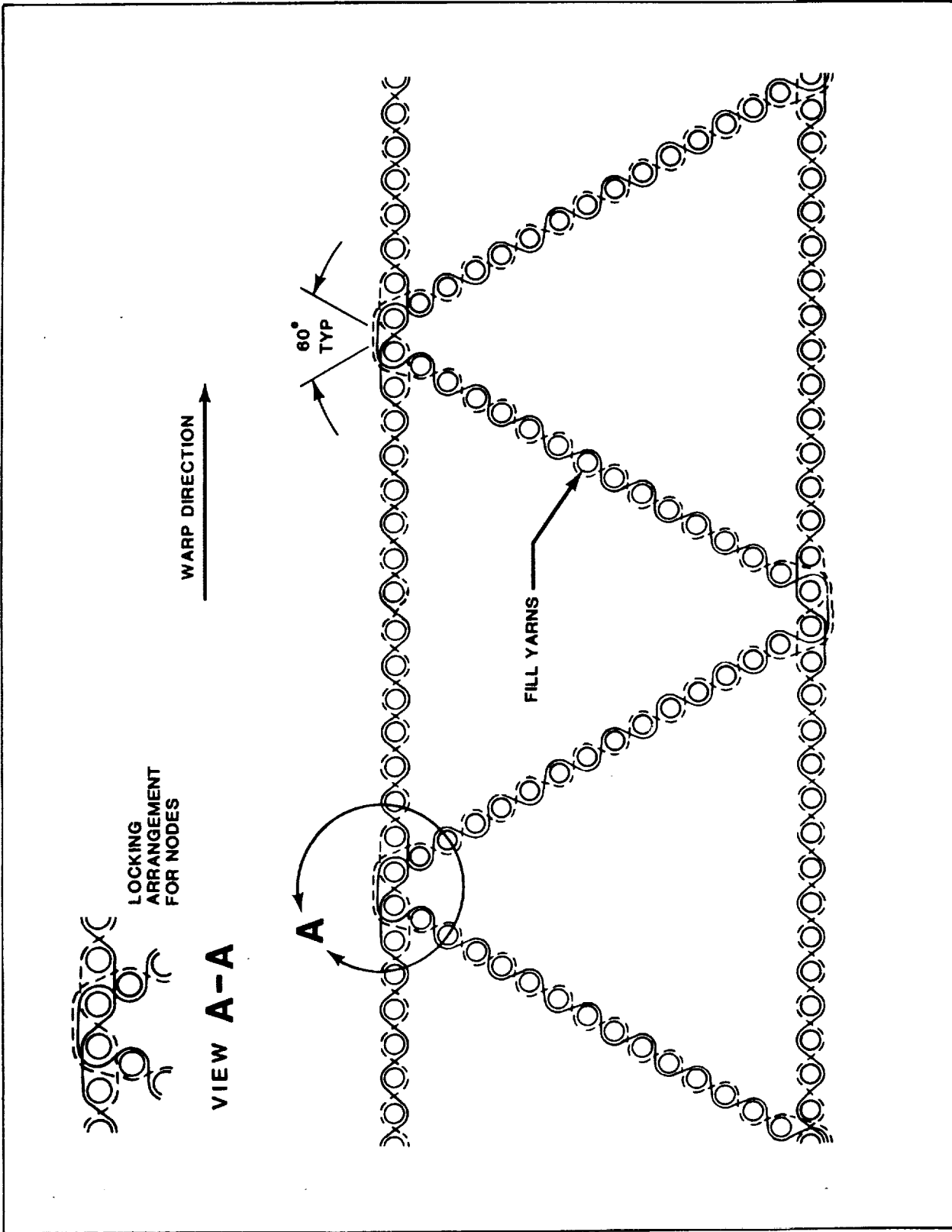

Figure 2-2  
YARN ARRANGEMENT OF FLUTED CORE FABRIC

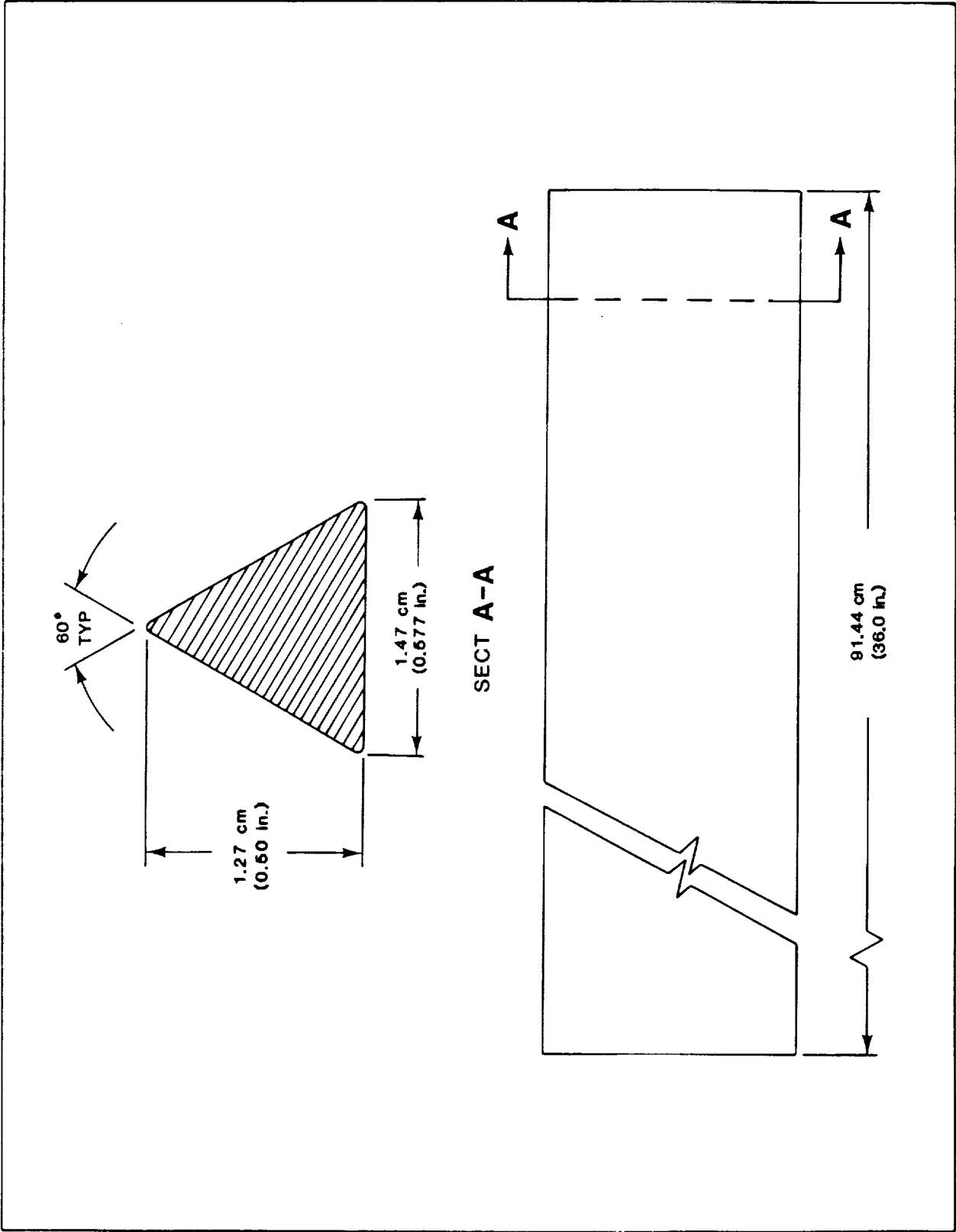

Figure 2-3  
CHECK MANDREL DIMENSIONS FOR TABI FABRIC

diameter range. Additional yarn was included in the procurement to allow for this lower yield. Further information on Nicalon yarn is contained in Appendix A.

2.2.2.1 Earlier work with weaving Nicalon required that the warp yarns be protected during weaving by double serving (overlying) the yarn with 75 denier rayon, with each direction of serving having 4 TPI (Turns Per Inch). This spirally-wrapped fine yarn, the sizing on all the yarns, and other organic matter were removed later during the heat cleaning operation. A study was made to determine if the serving could be applied in a different manner to improve the protection of the Nicalon. Specimens were prepared using twisted and untwisted rayon yarns for serving, with different degrees of twist in the rayon. The specimens were abraded on a tester that reciprocatingly pulls yarns over chromed rods until yarns fail. As a result of this testing, it was decided to use rayon serving yarn with 6 TPI around the Nicalon. Sufficient rayon yarn for the entire warp system was twisted and served over the Nicalon. The required lengths of the served Nicalon were wound on plastic spools using a modified winding machine designed for fragile yarns; a sufficient number of these spools were prepared to provide all the warp ends for the Item 1 and 2 SiC TABI fabrics.

2.2.3 Loom Set Up and Debugging. A modified Crompton & Knowles Cotton King loom used for previous NASA programs was prepared for the new effort. Setting up involved cleaning the creels behind the loom as well as all major parts of the loom. The stamped heddle eyelets and dents of the reed were inspected and found to be worn from the prior run of the abrasive Nicalon. These were all replaced with new parts. Also, the pin-covered take-up roll, the roll that pulls the just-woven fabric through the loom, was re-covered with a rubber card clothing to minimize damage to the woven fabric. All mechanical parts of the loom were inspected and lubricated, and the loom operated to check the shuttle box motion, cylinder head motion which controls the loom programming, and all other loom mechanisms. The spools of warp yarn were placed on the creels, drawn through lease bars, as well as through the heddles and the reed. Yarns for the rib fabric were drawn through a separating-comb and then through driven nip rolls, which is essential to obtaining the correct flute cell size in the fabric. These too were also drawn through the heddles and the reed. All yarns past the reed were attached to a disposable glass fabric apron which was positioned around the cloth roll and take-up roll. A minimal amount of warp fiber was lost since only a few inches are necessary to be tied to the leader fabric. The apron served to pull the start-up fabric during debugging. A schematic of the loom set-up is seen in Figure 2-4.

2.2.3.1 Initial attempts to weave the SiC TABI fabric resulted in an unpredictable problem. The rayon serving on many of the warp yarns broke as the fibers approached the reed, and the rocking motion of the reed stripped the rayon serving from the yarn. This produced an accumulation of serving that could not pass through the dents of the reed. This is seen schematically in Figure 2-5. It was necessary to stop the loom frequently to remove these accumulations. The rayon breakage was partially alleviated by adjusting the timing of the shuttle to correlate more precisely with the position of the reed. The second corrective action taken involved raising the fabric hold-down bar. The additional space between the race plate and bottom face warp yarns allowed the fibers to move downward freely, thus alleviating crowdedness in the reed dents, as seen schematically in Figure 2-6. After these adjustments, breakage of the serving yarn no longer occurred.

A considerable amount of time was lost while resolving this situation, however production increased tremendously afterward. Though the rayon breakage hindered the weaving process, neither the SiC warp yarn nor start-up fabric suffered damage.

2.2.4 Weaving. Weaving continued after debugging without incident. Following the debugging process, weaving of the SiC TABI fabric continued without interruption. Fabric was inspected for the correct cell size and any weaving defects. Flutes were verified for proper dimensions by inserting 13 check mandrels in adjacent cells of relaxed fabric. Very

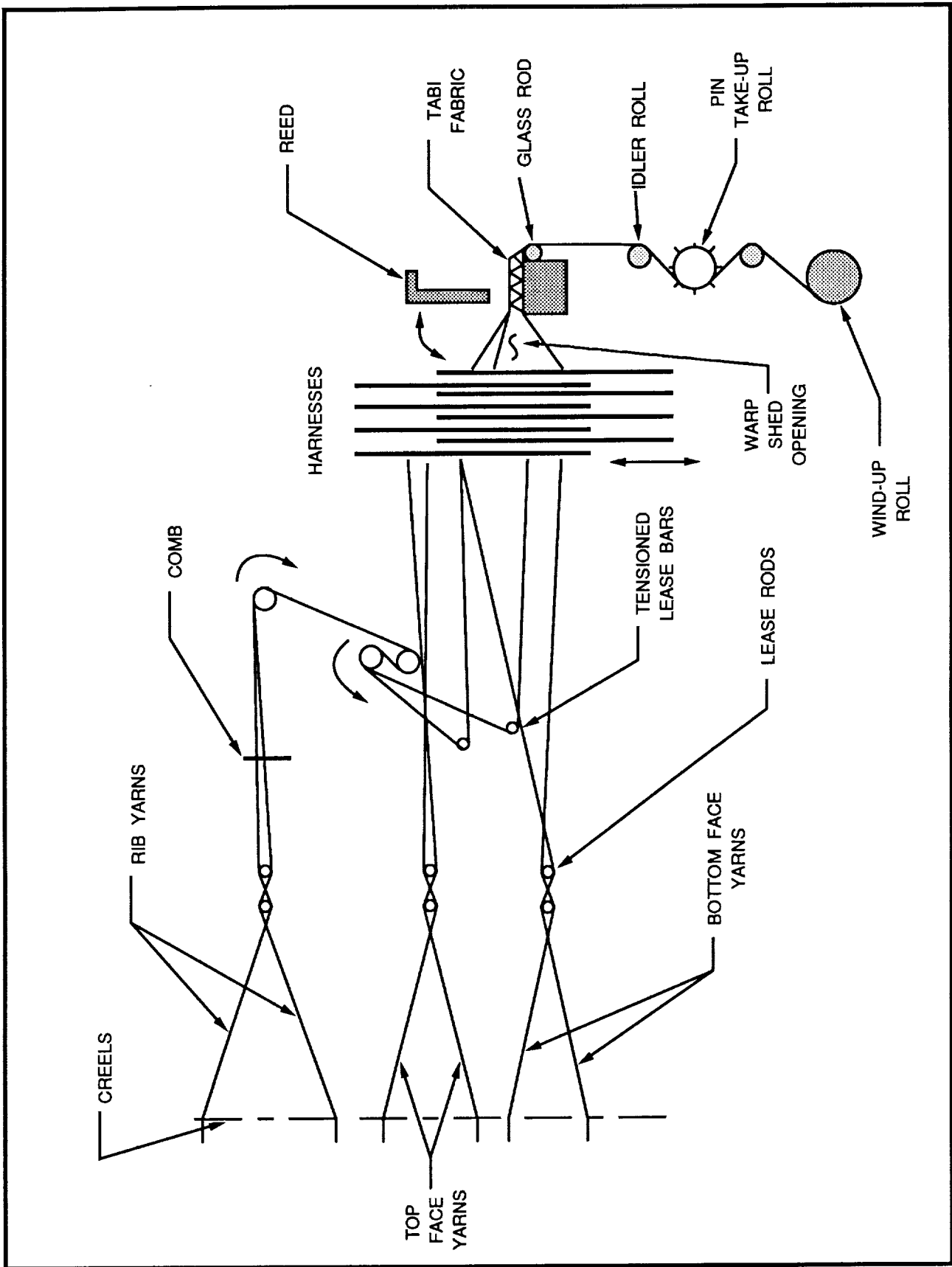

Figure 2-4  
 SCHEMATIC VIEW OF LOOM SET-UP  
 SHOWING PATH OF WARP YARNS FROM CREEL TO FABRIC

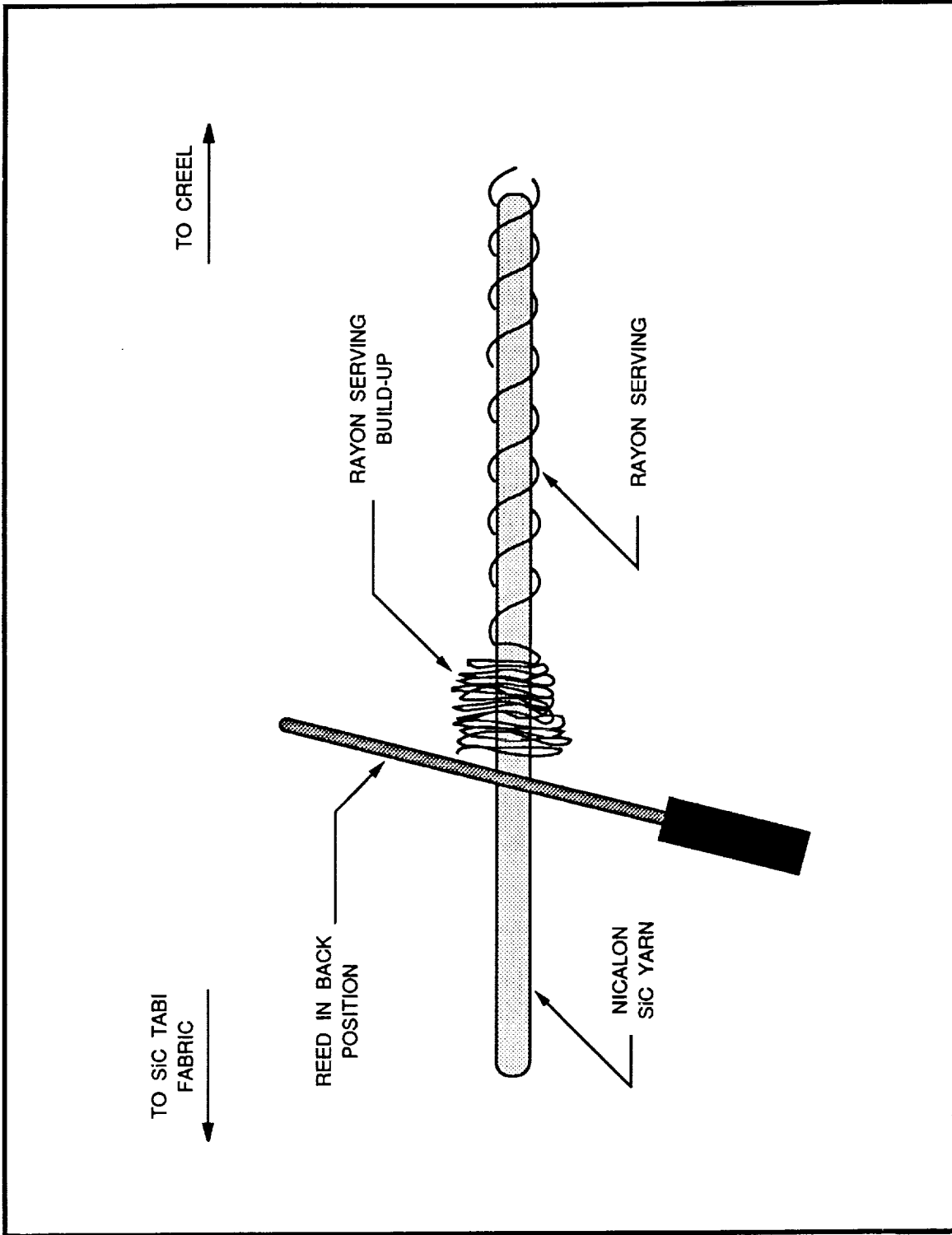

Figure 2-5  
STRIPPED RAYON SERVING

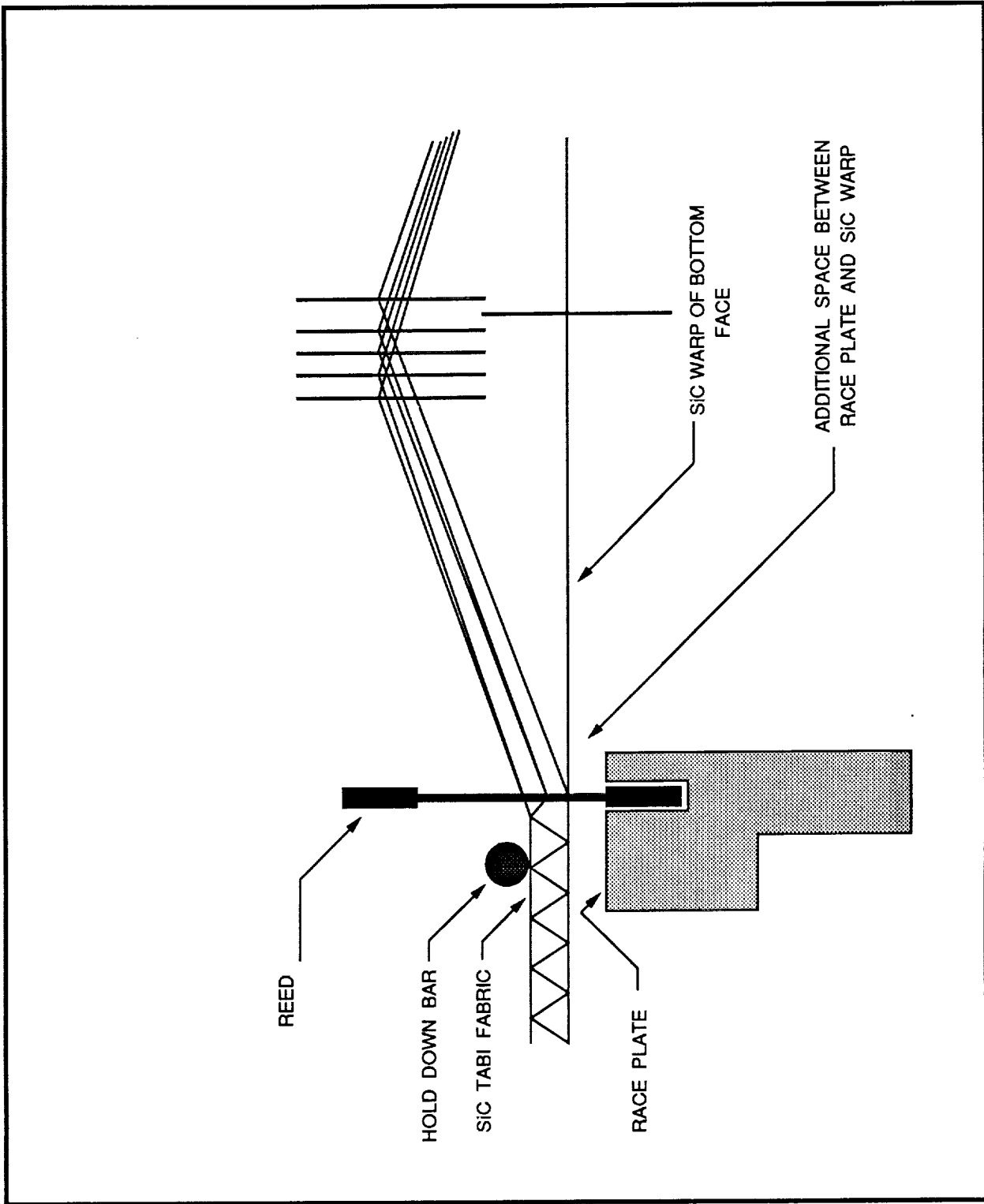

Figure 2-6

NEW POSITION OF HOLD DOWN BAR

few weaving defects were observed. The SiC fluted core fabric was now ready for insertion of insulation.

2.2.5 Insulation Preparation. Ceramic insulation for TABI panels must be in rigid form suitable for cutting into mandrels that can be easily inserted into the flutes of the woven fabric. The insulation mandrels ideally should have a lower cross section than the fabric's flutes. This allows for easy insertion into the fluted core fabric. After subsequent heat treating, the insulation mandrels must exhibit sufficient resiliency to expand and fill the flutes. The Ultrafiber insulation could only be supplied in a soft batting form requiring a further rigidizing process. Pre-rigidized Saffil alumina boards were available from the supplier.

2.2.5.1 Ultrafiber Processing. Two first article panel types of soft stitchbonded Ultrafiber felt with varying densities were received from 3M for evaluation. Each panel, 30.48 cm (12 inches) by 71.12 cm (28 inches), averaged 0.838 cm (0.33 inches) in thickness. A polyethylene scrim covering both surfaces and polyester stitching contained the layers of felt at fairly uniform thickness. According to 3M, panel 1 consisted of 6 layers of Ultrafiber felt, and panel 2 contained 7 layers. Physical characteristics of each panel sample were measured including as-received areal weight, heat-cleaned areal weight, panel spring-back thickness after heat cleaning, and weight loss due to scrim, stitching, and binder content. Densities of each felt panel were calculated at a nominal 1.27 cm (0.5 inch) thickness. These results are listed in Table 2-2. Also, mandrels were cut from a rigidized panel and heat cleaned to observe the insulation expansion in an unrestrained condition, Figure 2-7.

Examination of the heat-cleaned samples revealed voids created by the stitching needles during the stitchbonding process. Some concern existed as to whether the voids would disappear during heatcleaning of the fluted core fabric containing the felt. It was believed that voids could result in heat paths during service and that loosely filled flutes might contribute to TABI failure during mechanical vibration. To examine this possibility, two specimens of SiC fluted core fabric were insulated with the two types of Ultrafiber felt. They were then heat cleaned for 4 hours at 454°C (850°F) to allow the insulation mandrels to fully expand within the fabric flutes. Examination of these specimens indicated that the stitching voids collapsed during expansion of the insulation mandrels and that the fabric flutes were adequately filled, Figure 2-8. This springback capability of the Ultrafiber insulation was considerably better than Q-Fiber Felt used in prior TABI programs. The panel 1 Ultrafiber felt was procured since its density more closely approached the desired target of 3.57 kg/cubic meter (6 lb/cubic feet), than that of panel 2.

An as-received stitchbonded Ultrafiber panel is shown in Figure 2-9. Figure 2-10 is a close-up view of a panel showing the scrim and stitching points. Spacing between rows of stitching was approximately 10 mm (0.397 in), and stitching points were 4 mm (0.159 in) apart. Several Ultrafiber panels were received with areas of broken stitching, Figure 2-11, however this did not present any difficulties in subsequent processing.

2.2.5.2 In previous TABI work, insulation panels were rigidized by saturating them with an acrylic solution containing 80% deionized water and 20% acrylic. It was thought that this solution could be further diluted since the stitch bonding contained the felt to a uniform thickness. Two new solutions were evaluated, the first consisting of a 6:1, and the second, an 8:1 ratio of deionized water to acrylic. Samples of as-received stitchbonded Ultrafiber panels were saturated with 2 liters each of these solutions, and dried at 93.3°C (200°F) for 2 1/2 hours. Insulation mandrels were cut from both rigidized panels and exhibited adequate rigidity and strength for the insertion process. However, cutting several insulation mandrels from the from the rigidized panel containing the 6:1 acrylic solution produced an accumulation of acrylic on the cutting blade. This condition did not exist while cutting mandrels from the rigid panel of the 8:1 acrylic solution, so it was decided to continue the rigidizing process with the more dilute solution. Prior programs required that the batting



Table 2-2  
 PHYSICAL CHARACTERISTICS OF STITCHBONDED ULTRAFIBER FELT SAMPLES

FELT SAMPLE PANEL	AREAL WEIGHTS		HEAT CLEANED kgs/sq. meter	oz./sq. yard	SPRING BACK THICKNESS cm	inch	HEAT CLEANED DENSITY AT NOMINAL THICKNESS OF 1.27cm (0.5 inch) kgs/cubic meter	lbs/cubic foot	WEIGHT LOSS %
	AS-RECEIVED kgs/sq. meter	HEAT CLEANED oz./sq. yard							
1	1.26	37.30	1.15	34.00	3.8	1.5	90.2	5.67	10.0
AVERAGE	1.23	36.45	1.14	33.77			89.6	5.63	9.5
2	1.54	45.31	1.41	41.62	5.1	2.0	110.4	6.94	9.0
AVERAGE	1.64	48.37	1.51	44.45			117.7	7.40	9.0
	1.59	46.84	1.46	43.04			114.1	7.17	9.0

- AS-RECEIVED THICKNESS EACH STITCH-BONDED PANEL 0.838 cm (0.33 inch)  
 - DIMENSION OF EACH PANEL 30.5 cm X 71.1 cm (12 inch X 28 inch)

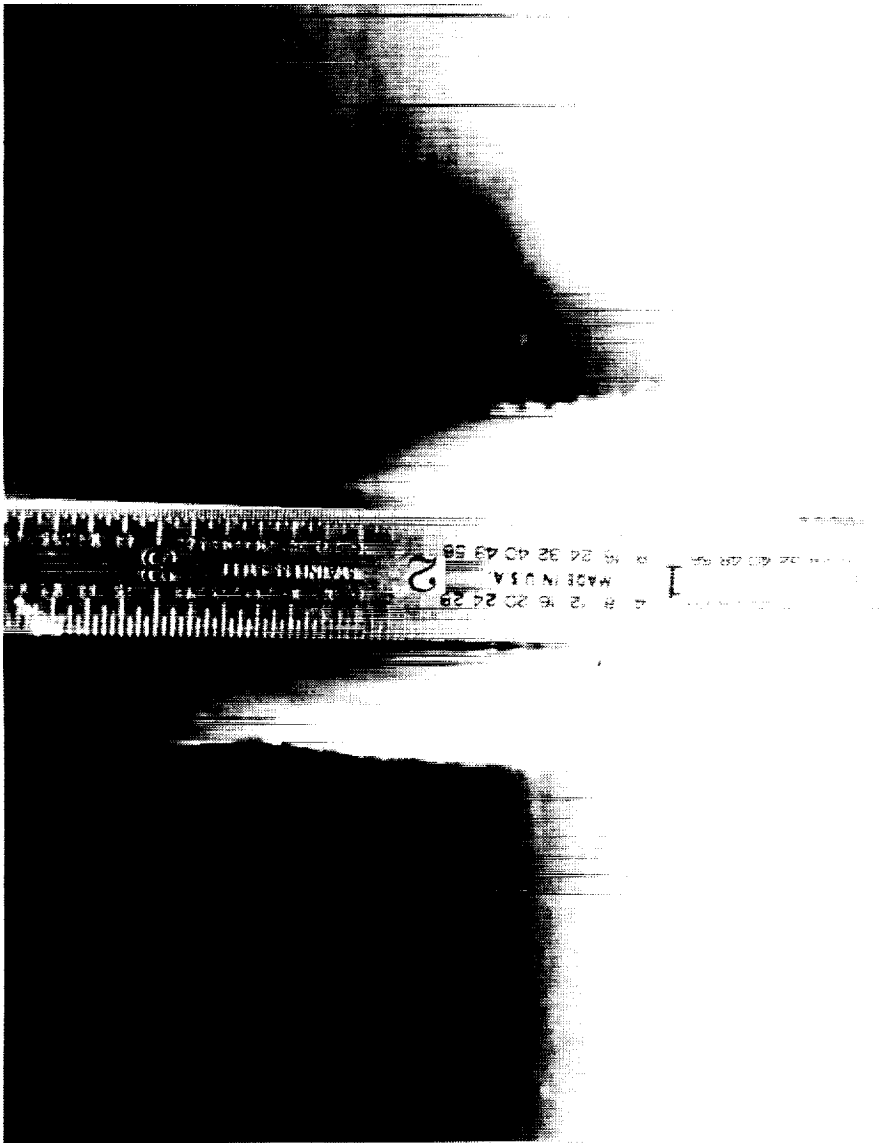

Figure 2-7  
CROSS SECTIONS OF ULTRAFIBER MANDRELS  
BEFORE AND AFTER HEAT CLEANING

ORIGINAL PAGE  
BLACK AND WHITE PHOTOGRAPH

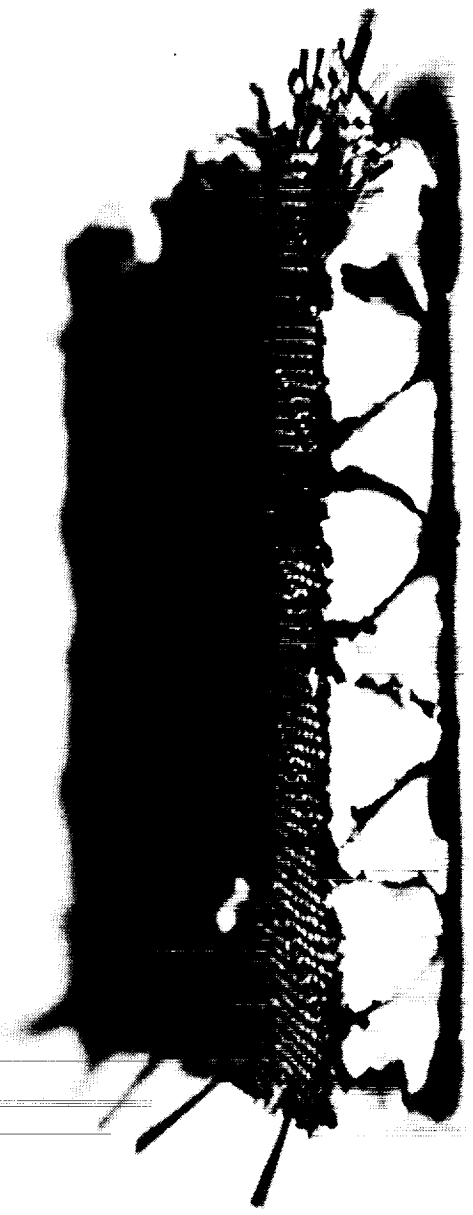

Figure 2-8  
ULTRAFIBER-INSULATED CORE SAMPLE AFTER  
HEAT CLEANING

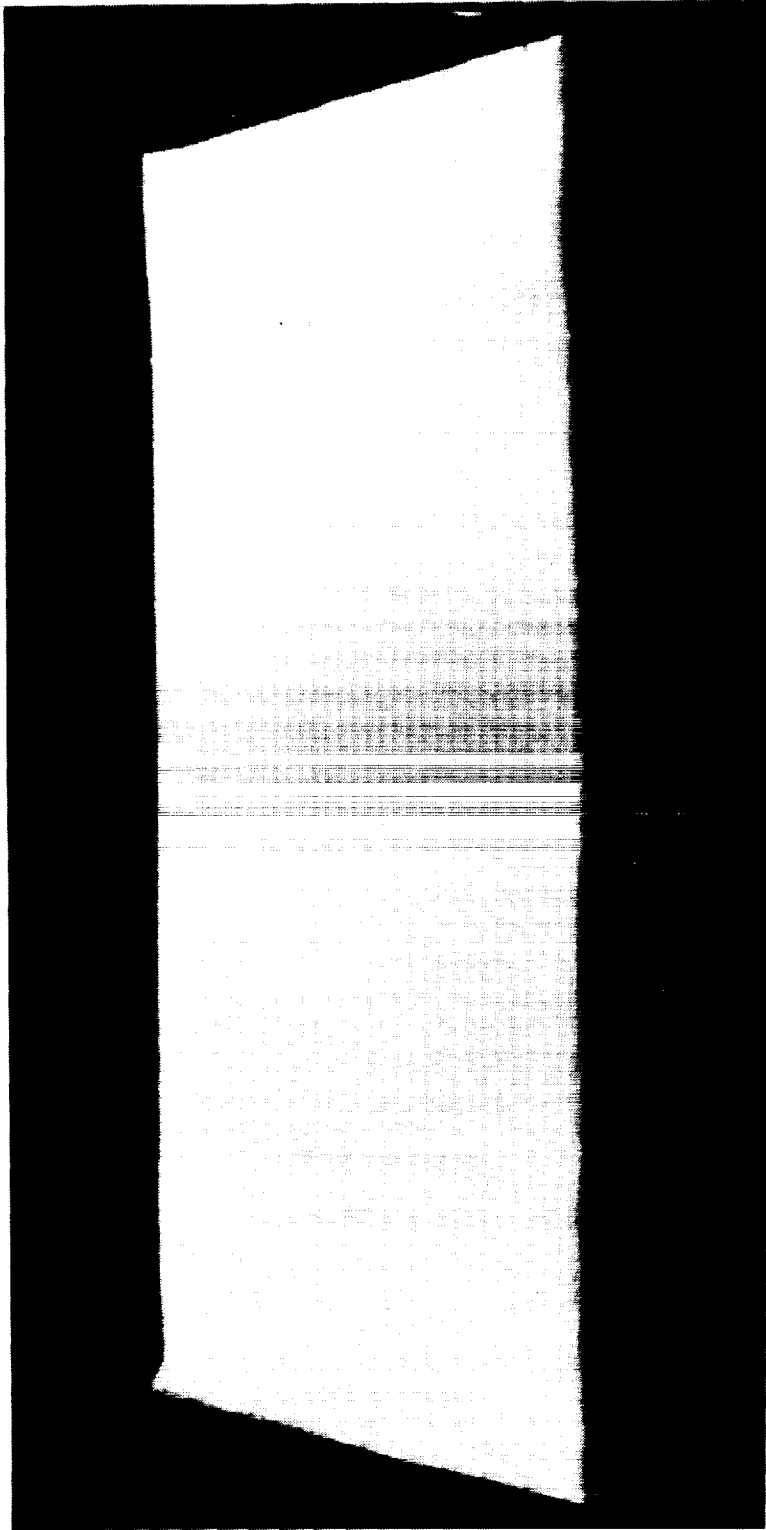

Figure 2-9

ULTRAFIBER PANEL AS-RECEIVED

ORIGINAL PAGE IS  
OF POOR QUALITY

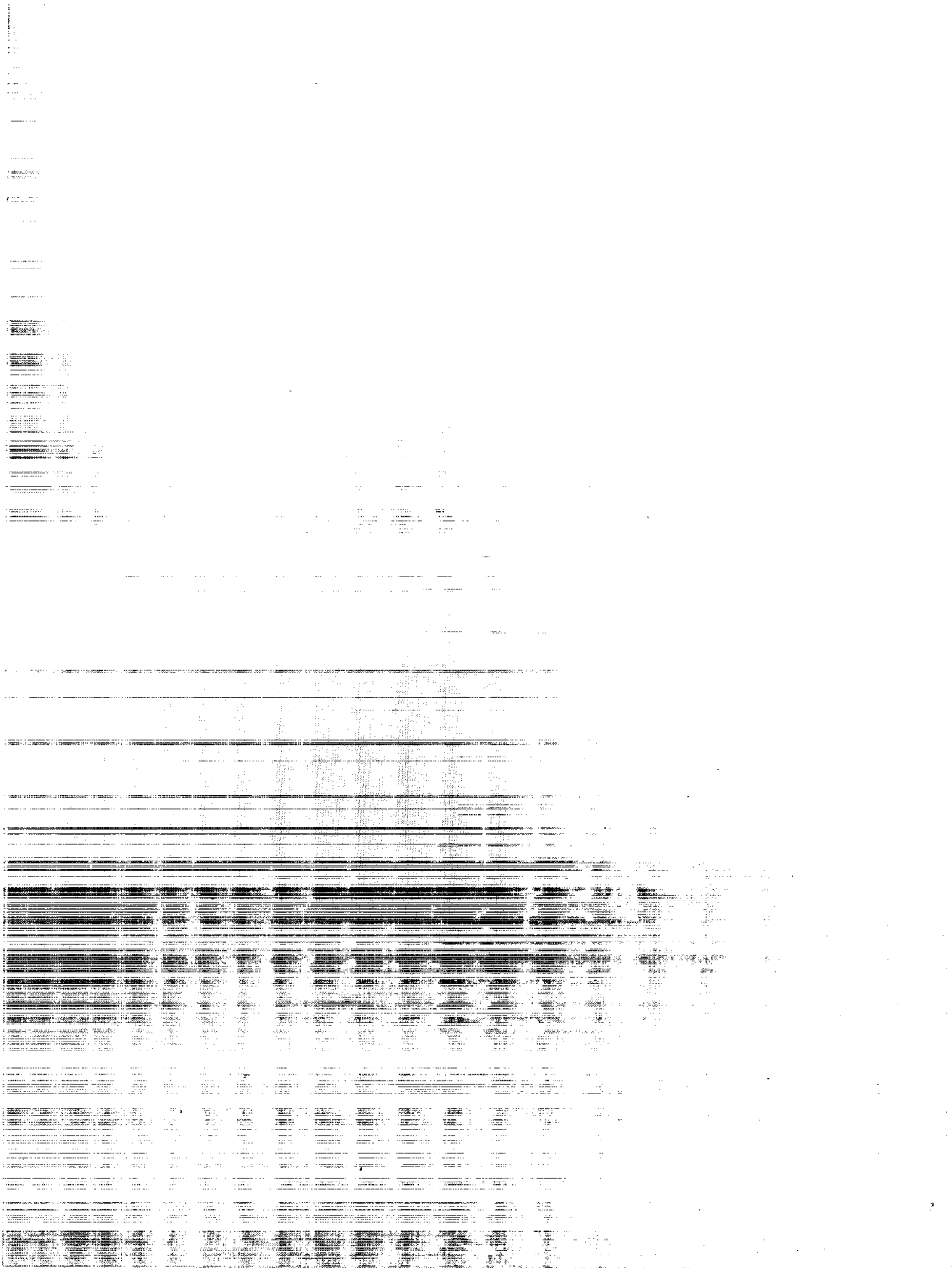

Figure 2-10  
CLOSE-UP OF ULTRAFIBER PANEL SHOWING  
SCRIM AND STITCHING

ORIGINAL PAGE IS  
OF POOR QUALITY

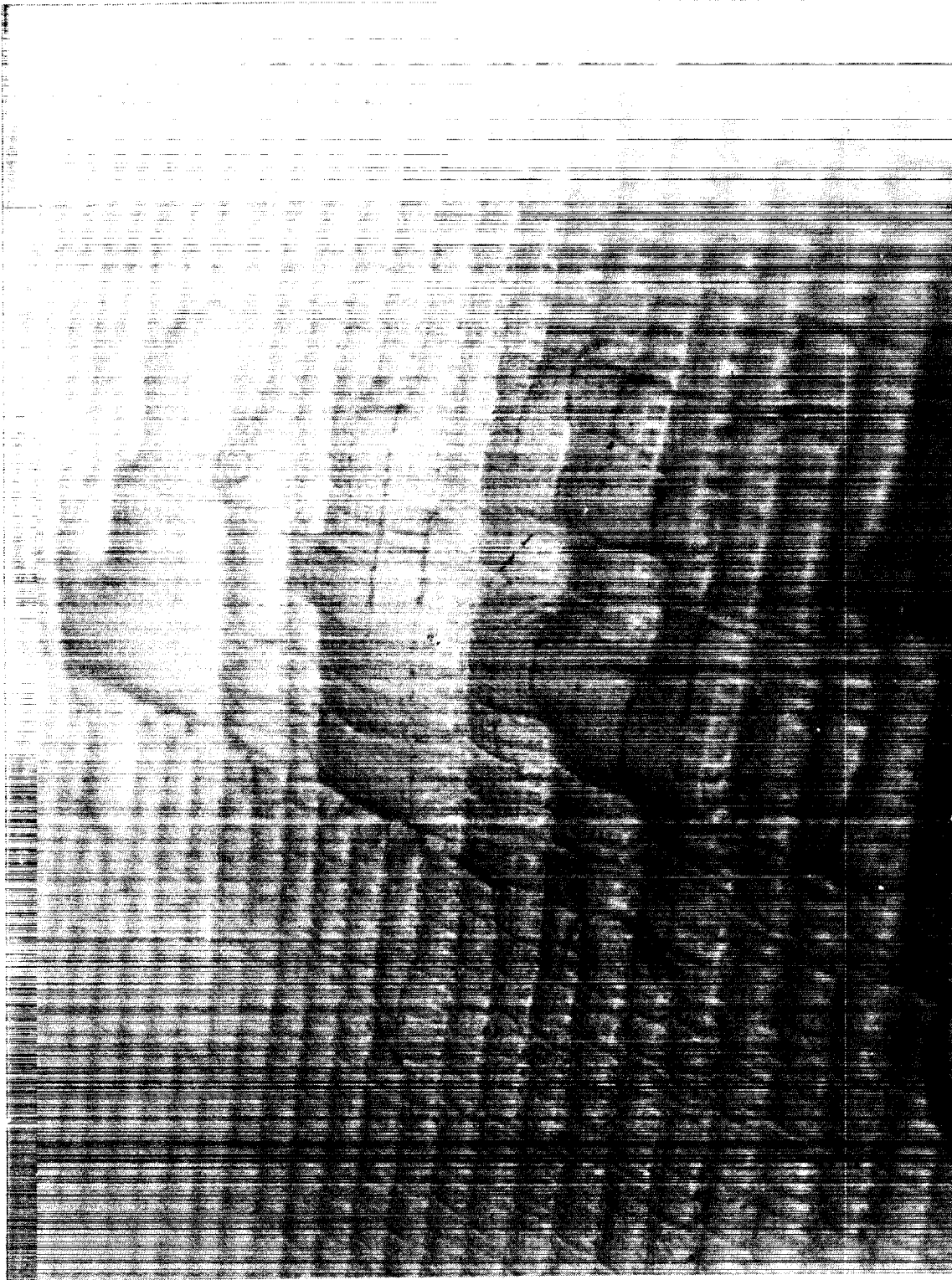

Figure 2-11  
BROKEN STITCHES IN AS-RECEIVED  
ULTRAFIBER PANEL

ORIGINAL PAGE  
BLACK AND WHITE PHOTOGRAPH

materials be compressed after saturating with resin solutions, however, since the Ultrafiber felt was stitchbonded and contained to a desirable thickness, this compression operation was unnecessary. It was found helpful though to cover the saturated mat with a plastic film and place it between aluminum plates without additional loading in order to keep the surfaces more flat. A rigidized Ultrafiber panel is shown in Figure 2-12.

The rigid insulation panels were cut into mandrels with the circular saw set-up used in a previous contract (NAS2-12693). Figure 2-13 illustrates an insulation mandrel cut from a rigidized Ultrafiber panel.

Careful handling was necessary while cutting these mandrels. At certain instances, the cutting edge neared a row of stitching points of the Ultrafiber felts, and when this occurred, the cut edge would sometimes chip away. A cross section of a mandrel illustrating the voids caused by the stitchbonding is shown in Figure 2-14. The cutting blade width, 2.38 mm (0.0938 in) accounted for approximately 30% loss of insulation to shavings. Unfortunately, suitable thinner blades were not available.

2.2.6 Insertion of Ultrafiber Mandrels. In prior developments of TABI materials, a major concern was the lengthy time required to insert the rigidized insulation materials. One reason for this situation was the need to insert reasonably straight, fragile, abrasive mandrels into fabric flutes which inherently are not perfectly straight. To overcome this problem, several techniques have been evaluated with limited success. A most promising approach is to make an insulation mandrel with a small cross section that inserts readily, but which subsequently expands to fill up the flute at the proper density. For this effort, mandrels were cut undersized as shown in Figure 2-15. Also, an insertion tool devised for inserting the fragile Saffil insulation mandrels needed to prepare Item 2, under Paragraph 2.1.1 of this program, was used successfully for the Ultrafiber mandrels. The tool, shown in Figure 2-16, consists of 4 mil thick polyester film in the triangular shape (envelope) attached to the end of an oversized triangular, cross section, hollow nylon mandrel. The procedure involved placing an insulation mandrel inside the polyester envelope and then pulling the nylon mandrel through the fabric flutes, Figure 2-17. This insertion technique facilitated the insulation operation considerably, and also minimized the breakage of mandrels to less than 3% of the cut mandrels. In the previous contract, NAS2-12693, nearly 15% of cut insulation accounted for broken mandrels.

2.2.6.1 Saffil Processing. Previous experimental work with Saffil alumina insulation involved using a flexible organic free-mat. The alumina fiber mat, approximately 3.8 cm (1.5 in.) thick was rigidized by impregnating it with an acrylic resin solution, compressing, and then drying. This rigidizing operation was similar to that described in Paragraph 2.2.5.2 for the Ultrafiber stitchbonded felt exclusive of the compressing procedure. It was learned that Zircar Products, Inc. could supply pre-rigidized alumina panels compressed to the desired processing thickness. The fibrous alumina products consist essentially of 95.0% Al<sub>2</sub>O<sub>3</sub> and 5.0% SiO<sub>2</sub>, with an average filament diameter of 3 microns (1.182 x 10<sup>-4</sup> in). According to product data sheets, Saffil has a useful operating temperature of up to 1649°C (3000°F).

A first article rigid panel sample was supplied by Zircar and characterized in the as received and heat-cleaned states. The results of this first felt sample characterization are shown in Table 2-3, Sample 1. The density of the heat-cleaned panel at a nominal 1.27 cm (0.5 in.) exceeded twice the acceptable target value. The high density also led to a powdering effect of the felt after heat cleaning. Zircar indicated the fiber formulation was incorrect and made adjustments that would produce a felt panel of the required density. Upon forming the alumina board, Zircar attempted to achieve a binder content of approximately 15-20%. Yet, during the felting process much of the binder escaped and only 1.5% binder could be accounted for after heat cleaning. The low binder content would have resulted in extremely soft and fragile insulation mandrels. After reformulation of the fiber density, Zircar submitted a second article of Saffil alumina board which is

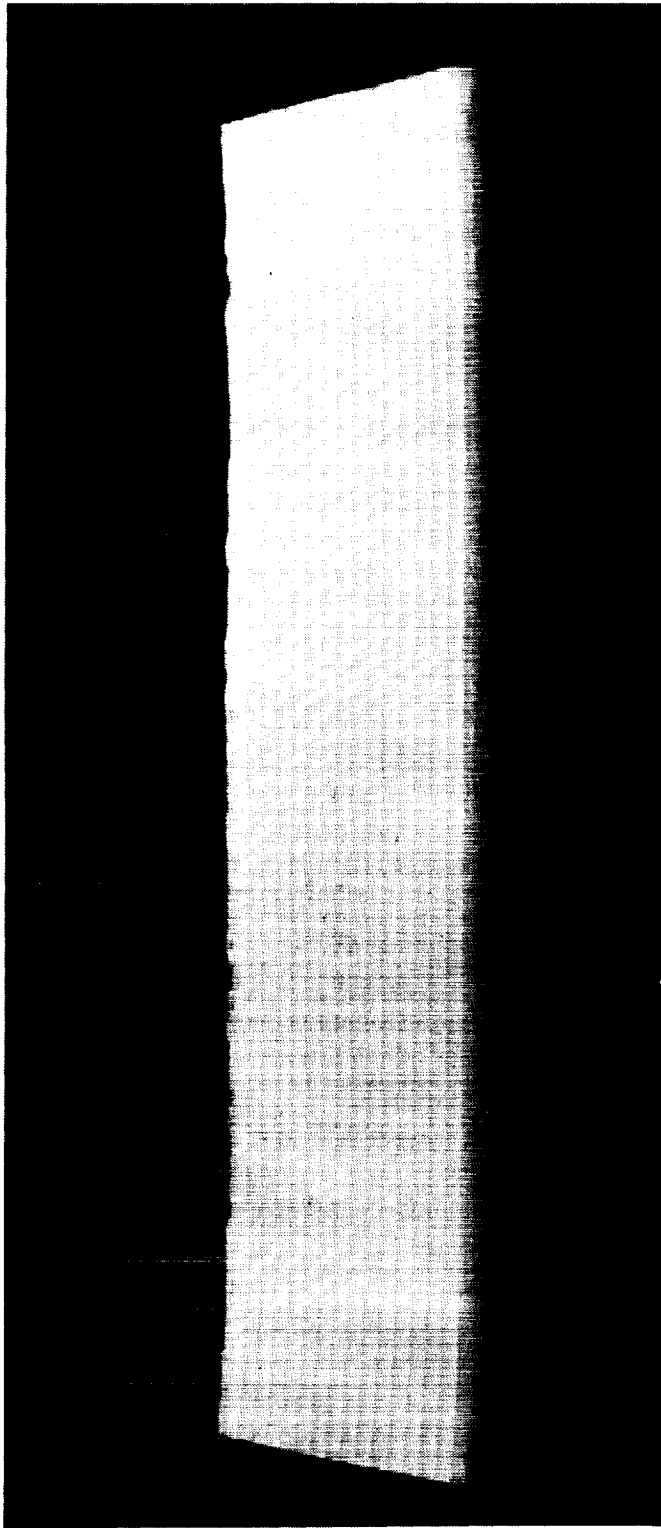

Figure 2-12

RIGIDIZED ULTRAFIBER PANEL



ORIGINAL PAGE  
BLACK AND WHITE PHOTOGRAPH

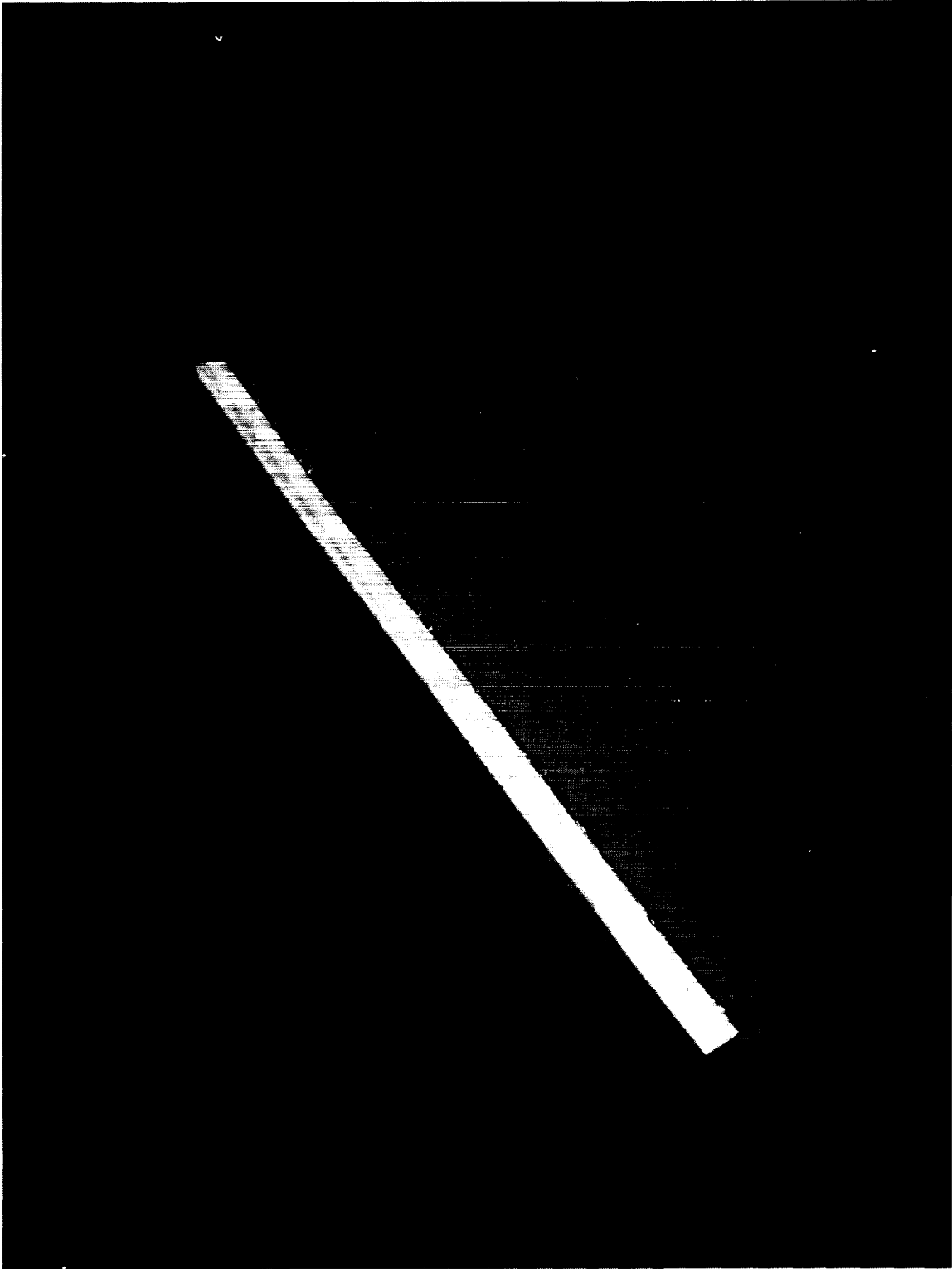

Figure 2-13  
INSULATION MANDREL CUT FROM ULTRAFIBER  
PANEL



Figure 2-14

CROSS SECTION OF ULTRAFIBER MANDREL

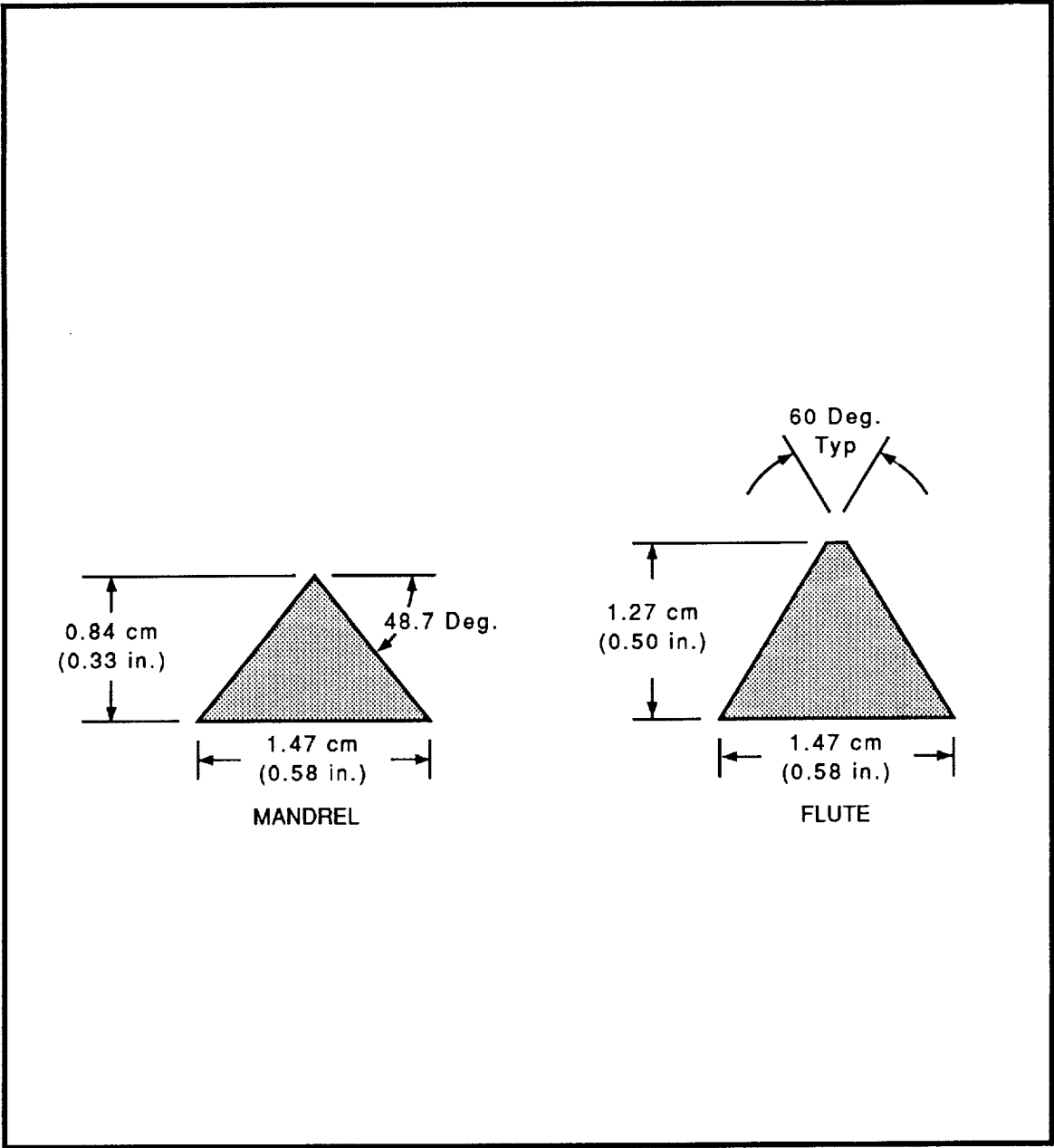

Figure 2-15

ULTRAFIBER MANDREL and FLUTE  
CROSS SECTIONS

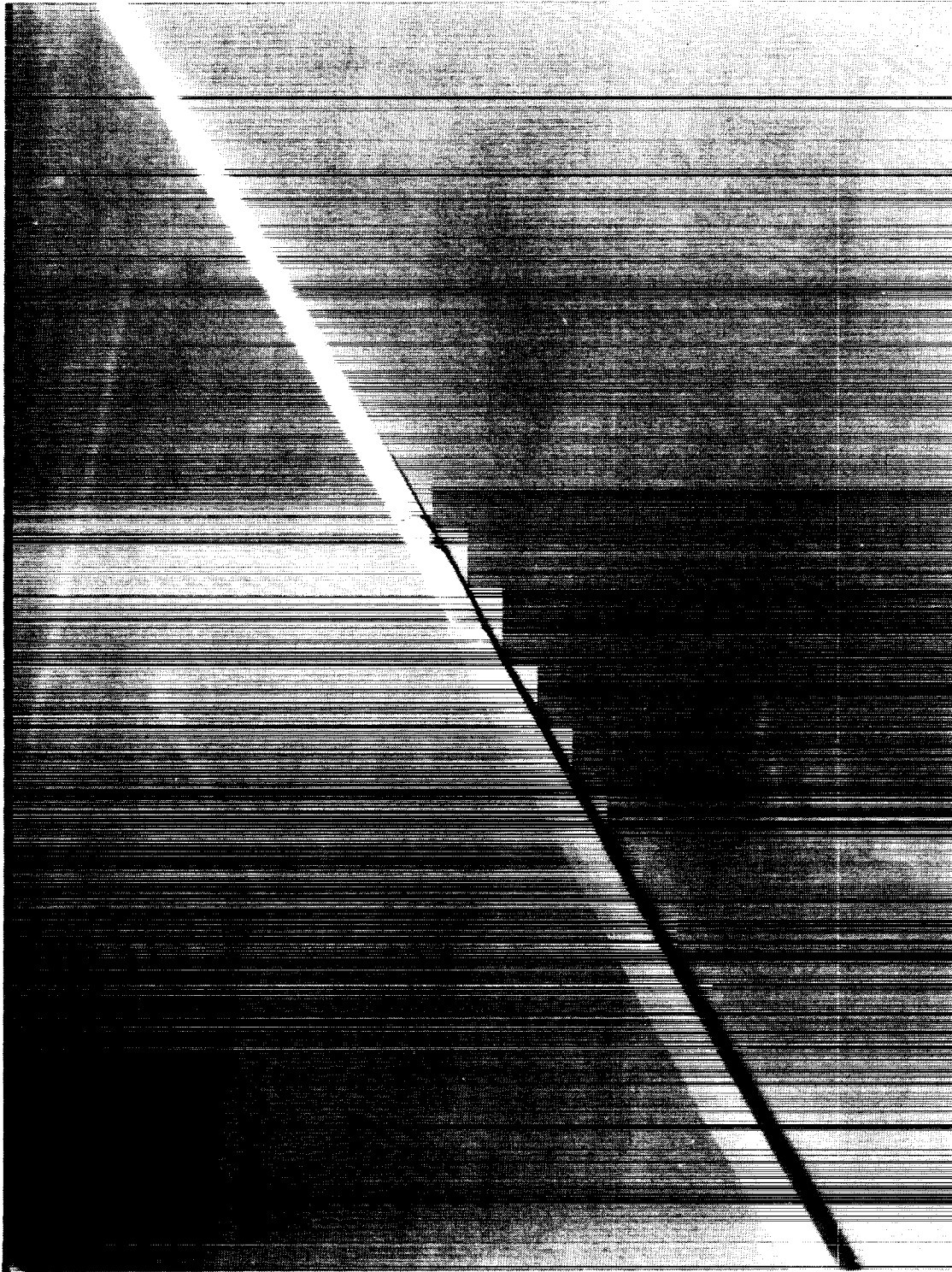

Figure 2-16

MANDREL INSERTION TOOL

ORIGINAL PAGE  
BLACK AND WHITE PHOTOGRAPH

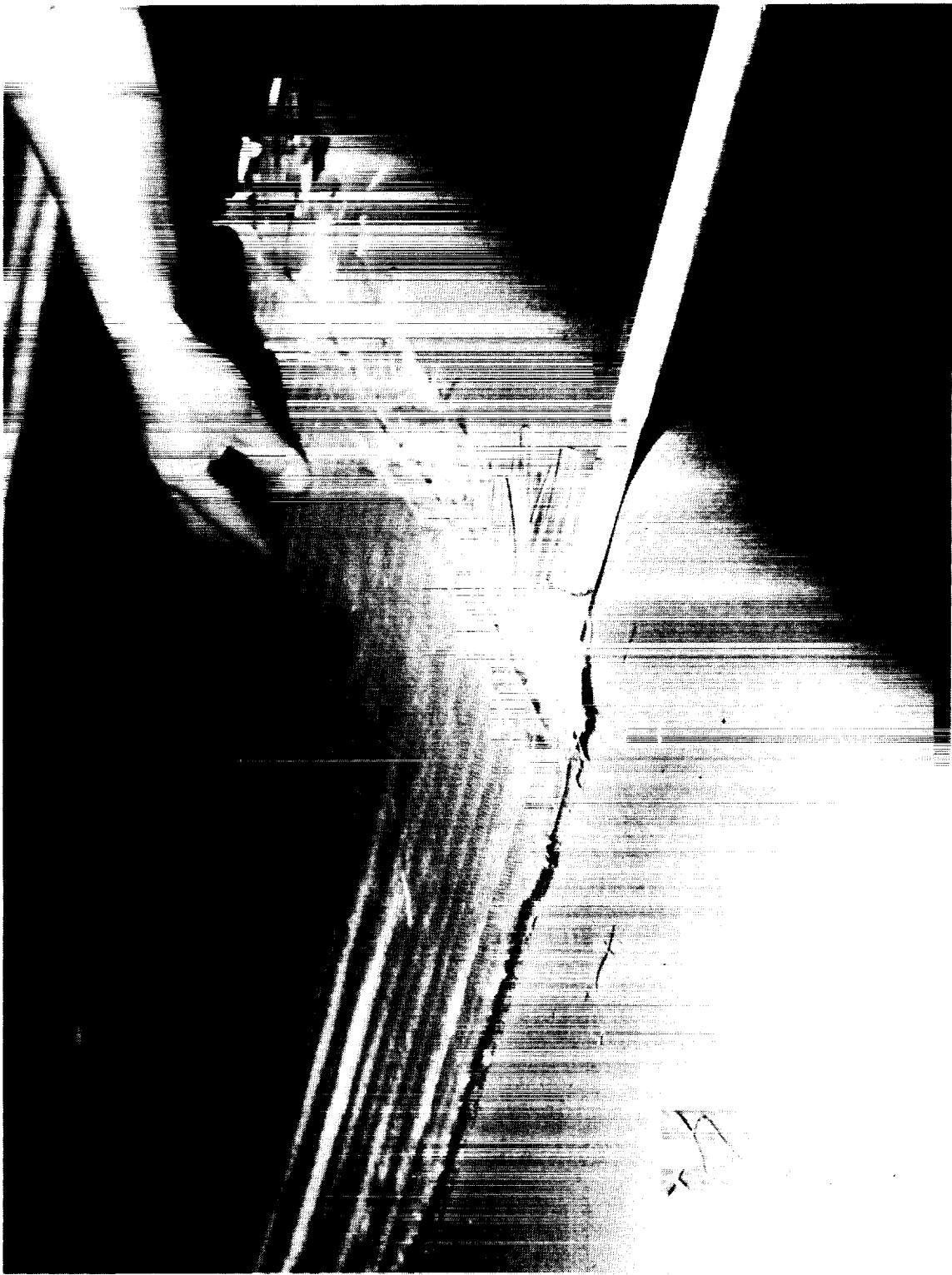

Figure 2-17  
FLUTED FABRIC BEING INSULATED USING  
INSERTION TOOL

Table 2-3

PHYSICAL CHARACTERISTICS OF SAFFIL ALUMINA INSULATION BOARD SAMPLE

FELT SAMPLE PANEL	AREAL WEIGHTS		HEAT CLEANED oz./sq.yard	SPRING BACK THICKNESS cm	HEAT CLEANED DENSITY AT NOMINAL THICKNESS OF 1.27cm (0.5 inch) kgs/cubic meter	WEIGHT LOSS %
	AS-RECEIVED kgs/sq.meter	HEAT CLEANED kgs/sq.meter				
1	3.13	92.40	3.09	3.81	241.8	1.5
2	1.26	37.03	1.21	3.18	94.98	3.4

- AS-RECEIVED THICKNESS EACH PANEL 0.97 cm (0.38 inch)  
 - DIMENSION OF EACH PANEL 45.7 cm X 71.1 cm (18 inch X 28 inch)

characterized in Table 2-3 as Sample 2. The heat-cleaned density was satisfactory and the integrity of the material appeared improved over the first sample. This may have resulted from less fiber beat-up while making the felt slurry assuming the felt contained longer fibers. The alumina insulation exhibited adequate springback thickness once heat cleaned, as seen in Figure 2-18. The binder content was reportedly increased to the maximum attainable by Zircar to approximately 3.4%. The surfaces of this as-received sample appeared crusty while the interior of the panel remained soft, suggesting that much of the binder had migrated to the surface. Insulation mandrels were cut from this panel, inserted into a sample of SiC fluted core fabric, and then heat cleaned to examine the expansion of the insulation while constrained within the fabric flutes. As seen in Figure 2-19, the insulation completely filled the SiC TABI fabric. Overall, the second article sample of Saffil insulation was improved, and rigid panels of this type were procured for the program.

An approved Saffil insulation panel, representative of Sample 2, 45.7 cm x 71.1 cm (18 in x 28 in) is shown in Figure 2-20. Several of the as-received panels had a yellow discoloration on the surfaces. After heat cleaning samples of the discolored areas for 4 hours at 538°C (1000°F), a greyish residue remained. Since contamination is a concern for this application, an attempt was made to identify the residue. Both surfaces and the center of a sample of discolored panel were analyzed semi-quantitatively, the results of which are reported in Table 2-4. Nickel, copper and zinc appeared higher on one surface than either in the center or the other surface.

Saffil mandrels were cut on a circular saw to the shape and dimensions of Figure 2-21. A full length Saffil mandrel is shown in Figure 2-22. The Saffil mandrels were more fragile than those cut from the Ultrafiber panels and required more care in handling. The cutting loss resulting from the width of the saw blade was about 30%, similar to the loss experienced with Ultrafiber.

- 2.2.6.2 Insertion of Saffil Mandrels. The special mandrel insertion tool described in paragraph 2.2.5.2 and shown in Figures 2-16 and 2-17, was originally made for inserting the fragile Saffil mandrels. The insertion tool reduced the risk of mandrel breakage, yet approximately 10% of the mandrels formed were broken during the insulation process. To eliminate this breakage entirely, it might be suggested to use a much higher binder content in future Saffil insulation board production.
- 2.2.7 Heat Cleaning. The SiC TABI panels of Saffil and Ultrafiber insulation were heat cleaned at 454°C (850°F) for 4 hours in a large gas fired, air circulating oven. All organic binders, yarn lubricants, and rayon serving were removed during the heat clean process. Clean, glass-covered drying racks were used to support the panels and avoid any contamination.
- 2.2.8 Characterization. Physical characteristics of representative samples of SiC TABI with Saffil and Ultrafiber insulations were measured and are presented in Table 2-5. All targeted values of each SiC TABI from Table 2-1 were closely attained. The measured areal weight of the SiC TABI fabric weighed within 1% of the targeted values, while the areal weights of each TABI item weighed within 3%; Slight inconsistencies in fiber weight, insulation density, and weighing techniques may all contribute to the minor variances of these areal weights. As seen in Tables 2-2 and 2-3, the areal weights of the selected insulation panels were below the required 1.22 kgs./sq. meter (36 oz./square yard) for the prescribed density. The cell height of the SiC fluted core fabric was very uniform throughout at 1.27cm (0.50 inch).
- 3.0 TECHNICAL PROGRAM, ITEMS 3, 4, and 5
- 3.1 Objectives

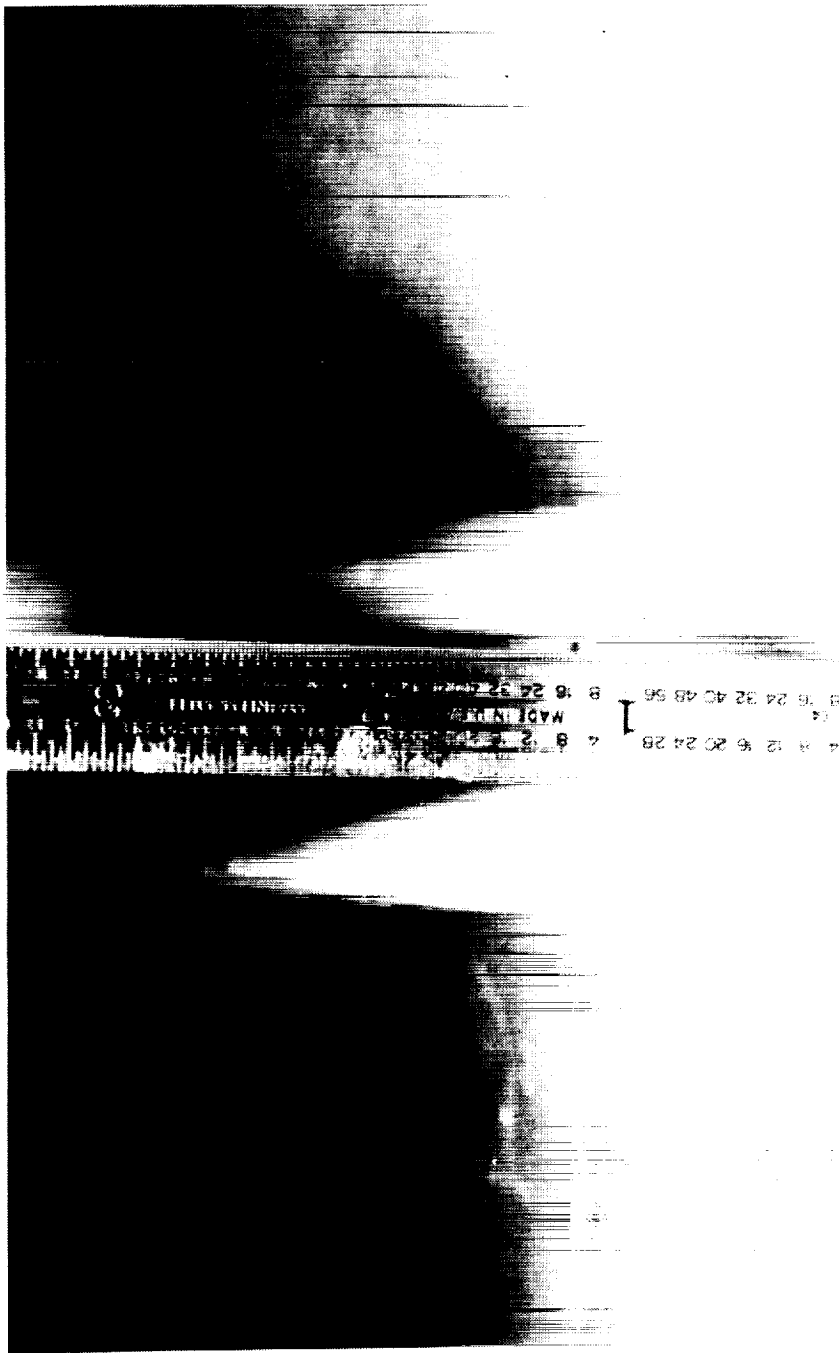

Figure 2-18  
CROSS SECTIONS OF SAFFIL MANDRELS  
BEFORE AND AFTER HEAT CLEANING

ORIGINAL PAGE IS  
OF POOR QUALITY



ORIGINAL PAGE  
BLACK AND WHITE PHOTOGRAPH

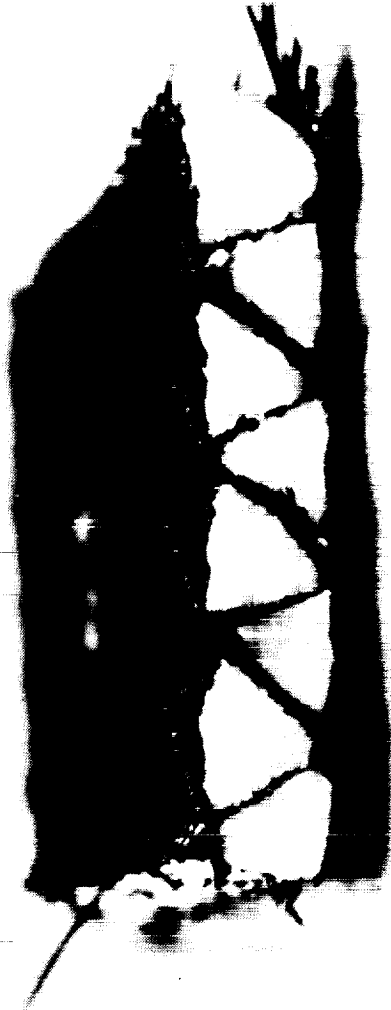

Figure 2-19  
SAFFIL-INSULATED SIC TABI SAMPLE AFTER  
HEAT CLEANING

ORIGINAL PAGE IS  
OF POOR QUALITY

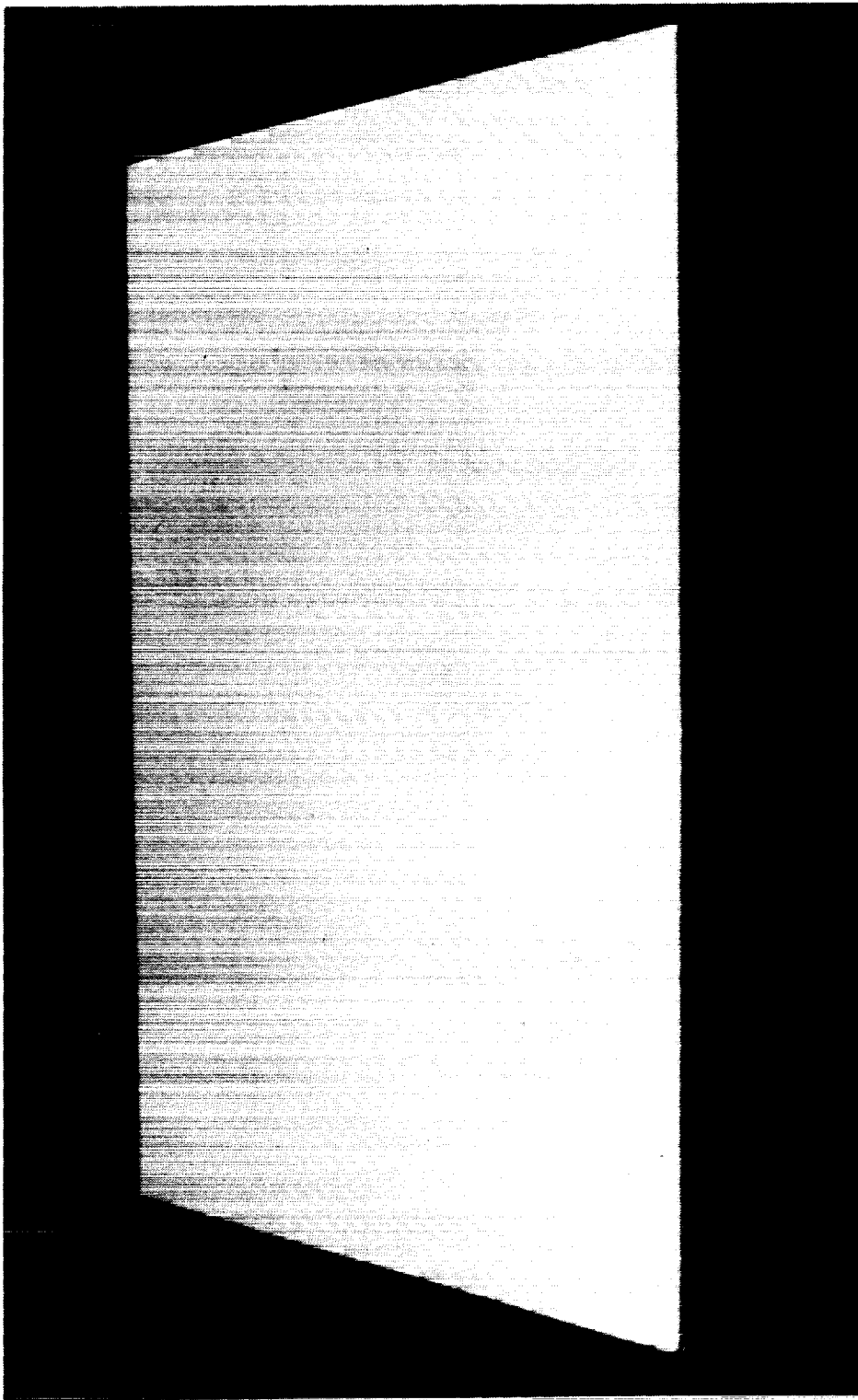

Figure 2-20

SAFFIL PANEL AS-RECEIVED

TO:

February 10, 1988

SEMIQUANTITATIVE ANALYSIS

	<u>A-(Interior)</u>	<u>A-(surface)</u>	<u>B-(surface)</u>
Al	49.7	50.7	48.7
Si	2.5	2.2	3.1
Mg	0.012	0.060	0.078
Mn	0.0019	0.0051	0.0058
Ni	0.022	0.040	0.10
Cr	0.0065	0.016	0.011
Fe	0.036	0.13	0.083
Ga	0.0048	0.011	0.014
B	ND<0.003	ND<0.003	0.0089
Pb	ND<0.006	0.0082	ND<0.006
Cu	0.0013	0.0089	0.021
Ca	0.0014	0.097	0.051
Sn	TR<0.001	TR<0.001	ND<0.001
V	0.0011	0.0019	0.0029
Na	TR<0.02	0.35	0.48
Ag	0.00023	nD<0.0001	ND<0.0001
Zn	ND<0.01	0.027	0.046
Zr	ND<0.005	0.018	ND<0.005
Other elements	nil	----->	

Table 2-4  
Analysis of Discolored Saffil Panels

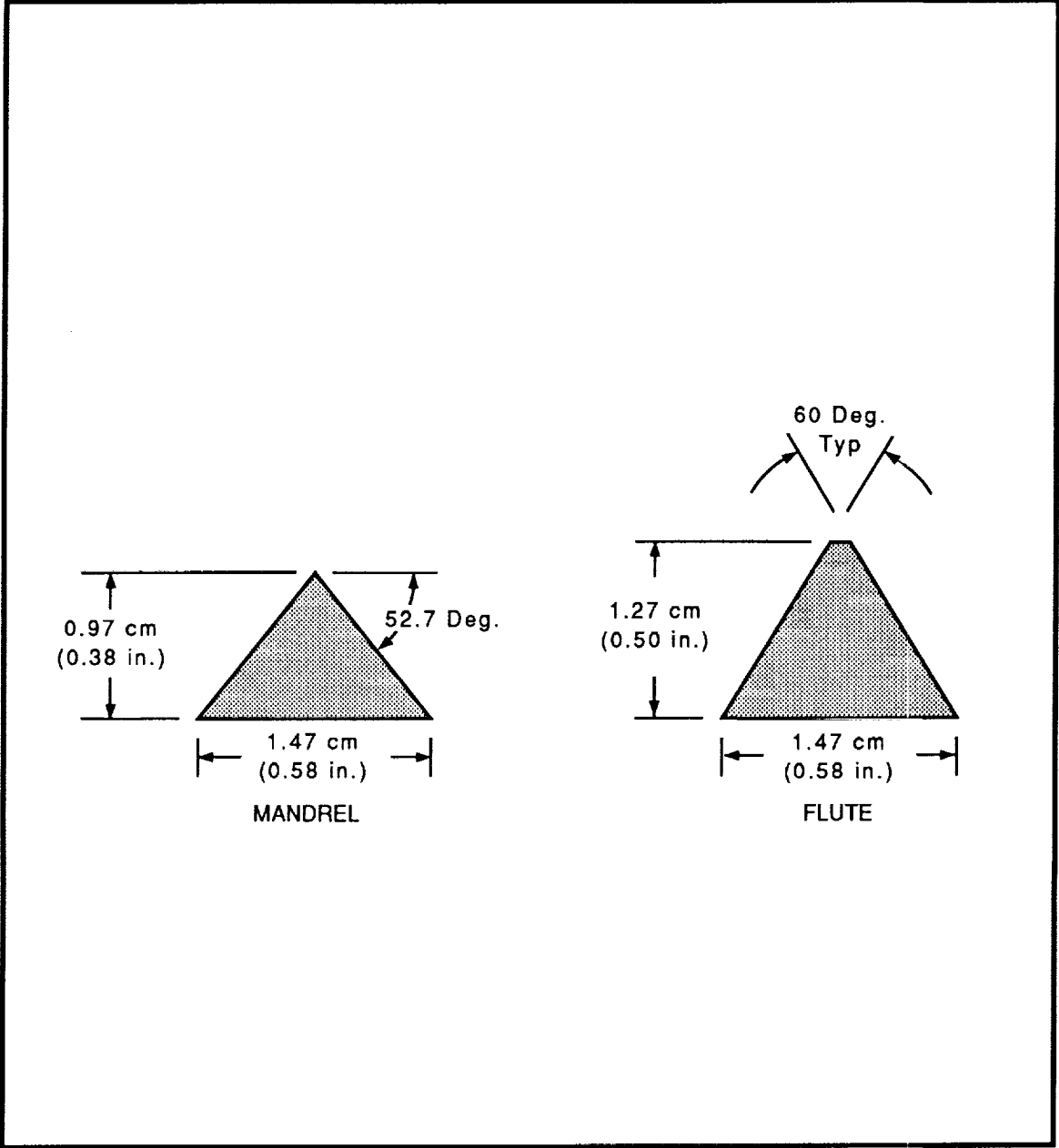

Figure 2-21  
SAFFIL MANDREL and FLUTE  
CROSS SECTIONS

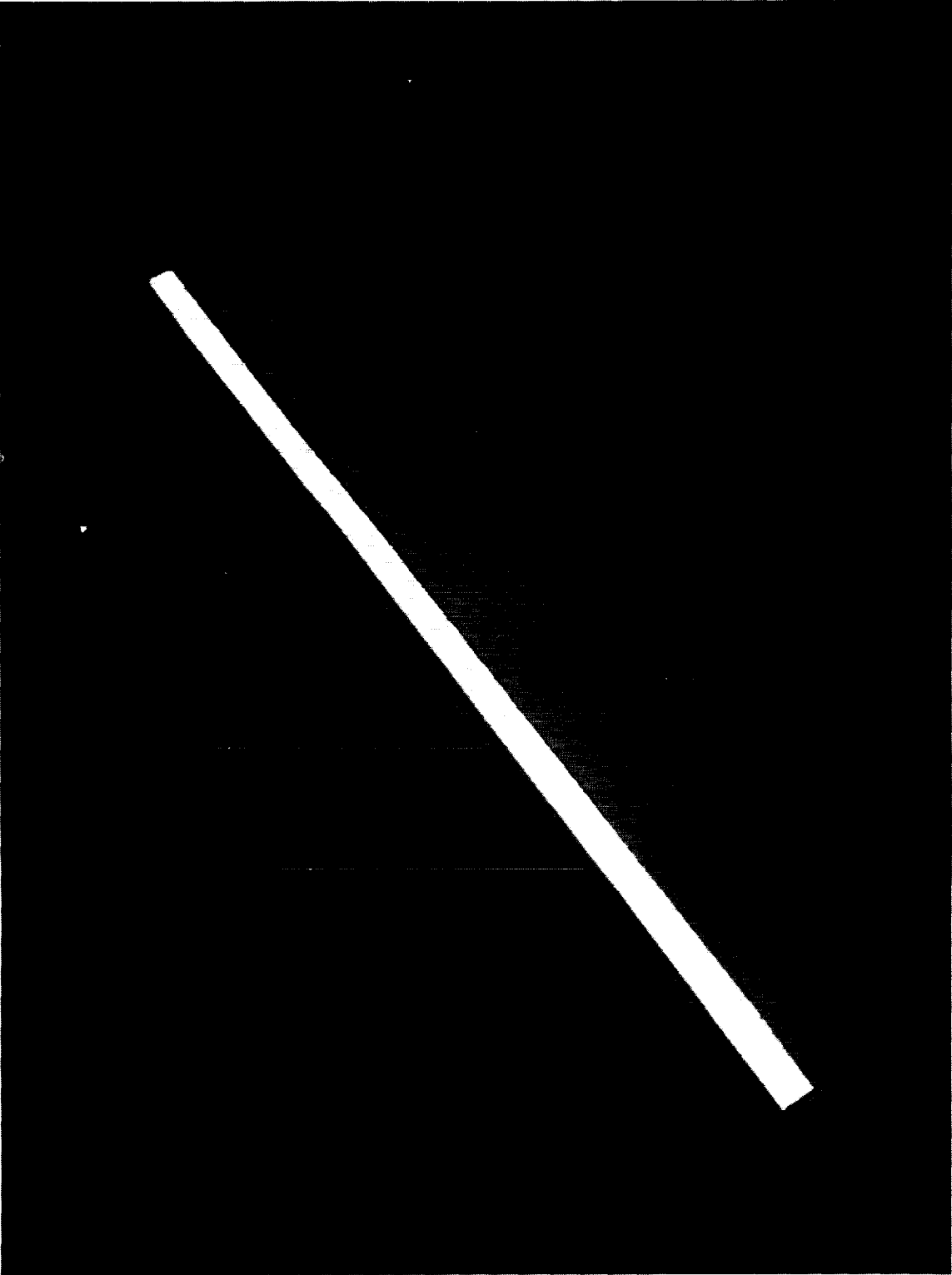
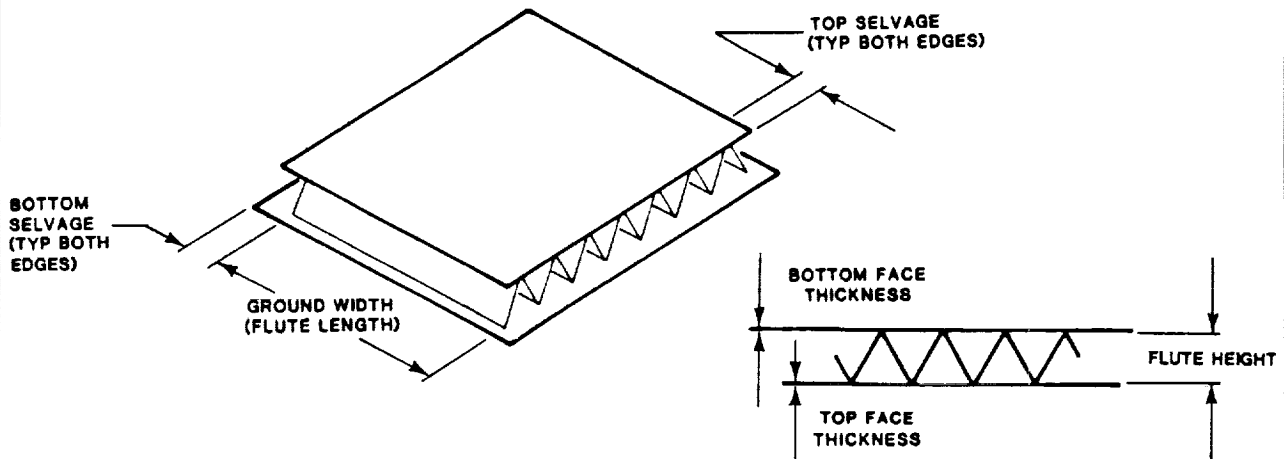

Figure 2-22  
INSULATION MANDREL CUT FROM SAFFIL  
PANEL

Table 2-5

ACTUAL CHARACTERISTICS AND DIMENSIONS  
OF ITEMS 1 AND 2 SIC TABI FABRICS

FABRIC YARN COUNT	MEASURED VALUES	
	ITEM 1 ULTRAFIBER	ITEM 2 SAFFIL
TOP FACE (WARP X FILL)		
ENDS/cm X PICKS/cm	6.50 X 9.45	6.50 X 9.45
ENDS/inch X PICKS/inch	16.0 X 24.0	16.0 X 24.0
RIBS		
ENDS/cm X PICKS/cm	6.50 X 6.90	6.50 X 6.9
ENDS/inch X PICKS/inch	16.5 X 17.5	16.5 X 17.5
BOTTOM FACE		
ENDS/cm X PICKS/cm	6.50 X 9.45	6.50 X 9.45
ENDS/inch X PICKS/inch	16.0 X 24.0	16.0 X 24.0
FABRIC AREAL WEIGHT		
kgs./sq. meter	1.183	1.183
oz./sq. yard	34.77	34.77
PANEL AREAL WEIGHT (INCLUDING INSULATION)		
kgs./sq. meter	2.314	2.453
oz./sq. yard	68.03	72.14
FABRIC FACE THICKNESS		
TOP FACE		
cm	0.043	0.043
inch	0.017	0.017
BOTTOM FACE		
cm	0.043	0.043
inch	0.016	0.016
FLUTE HEIGHT (OR CELL HEIGHT)		
cm	1.27	1.27
inch	0.50	0.50
GROUND WIDTH		
cm	66.68	66.68
inch	26.25	26.25
EACH SELVAGE (TOP AND BOTTOM FACE)		
cm	2.54	2.54
inch	1.00	1.00



- 3.1.1 Thirteen lineal meters, 72 cm (15 yards) of triangular cross section fluted core fabric 0.66 meters (26 in.) wide with a cell height of 1.27 cm (0.5 inch), were to be woven from Nextel low-boria aluminoborosilicate 440 yarn. The Nextel TABI fabric would be used to produce items 3, 4 and 5. Item 3 was to consist of 3.57 kg/cubic meter (6 lb/cubic feet) stitched-bonded aluminoborosilicate (ABS) batting Ultrafiber 440. Item 4 was to be insulated with 3.57 kg/cubic meter (6 lb/cubic feet) Saffil alumina batting. The final third of the remaining Nextel 440 fluted core fabric was to be provided without insulation as Item 5. Four panels of each item were to be supplied, three being 122 cm (4 feet) long, and 1, 91 cm (3 feet) long. The target characteristics and the dimensions of the Nextel TABI established by NASA are shown in Table 3-1.
- 3.1.2 Experience gained from making and inserting insulation mandrels for Items 1 and 2 was expected to facilitate production of Items 3 and 4. However, Nextel 440 fiber had never been woven into TABI type fabrics and it was difficult to predict its weavability.
- 3.2 Program Plan. The flow chart in Figure 3-1 defines the tasks required to produce the Nextel 440 TABI panels. The discussion that follows includes the effort involved in performing these tasks.
- 3.2.1 Fabric Design and Programming. The same tasks noted in paragraph 2.2.1 for designing and programming Nicalon fluted fabric apply to the Nextel 440 TABI fabric. Modifications in the original design were required to provide for changes in the target warp yarn count. The schematic of this design was identical to that shown for the Nicalon fabric in Figure 2-2, and the check mandrels in Figure 2-3 were also to be used for the inspection of Nextel TABI fabric.
- 3.2.2 Yarn Procurement and Preparation. Nextel 440 1000 denier 1/2 yarn with a 2.7 Z twist was procured and prepared for weaving. According to the supplier, this low boria ceramic fiber yarn is made up of 2 strands of 1000 denier tow material, each composed of 390 oval cross section continuous filaments having a diameter range of 10 to 12 microns (4 to 4.8 x 10<sup>-4</sup> in). At 1000 denier, the yarn yield is 1000 gm/9000 meters (2232 yards/lb). Fiber tensile modulus of elasticity is 186 GPa (27 x 10<sup>6</sup> pounds per square inch), approximately 25% higher than Nextel AB 312 fiber used on previous NASA programs. The Nextel 440 ceramic fiber consists of 70% aluminum oxide by weight. Nextel 440 appeared desirable for consideration in this effort because of its increased strength over Nextel AB 312 after exposure to elevated temperatures. Its high modulus and thus its increased brittleness over Nextel AB 312 left questions concerning its weavability.
- 3.2.3 Loom Set Up, Debugging and Weaving. Upon completion of Items 1 and 2, the SiC warp spools were removed from the creels and all equipment cleaned. All potentially abrasive surfaces were inspected and polished. Many of the "U" shaped metal tensioning weights were found to be grooved from weaving the abrasive SiC yarn. To minimize the abrading of the Nextel ceramic fiber all the tensioning weights were replaced with new ones. Creels were loaded with the predetermined number of spools of Nextel 440 yarn for each layer fabric required. The warp fibers were drawn into the loom through the heddles and through a new reed to obtain the correct warp yarn spacing. The creel set-up is shown in Figure 3-2. The warp yarns entering the back of the loom are seen in Figure 3-3. The loom set-up was identical to that illustrated in Figure 2-4. Upon completing the loom set up, debugging was initiated.
- 3.2.3.1 Initial debugging led to much breakage of warp yarns from both the top and bottom face sheets. The breakage of these fibers resulted from improper tensioning of the warp spool packages on the creels. When weaving the top and bottom faces, loops of fibers were formed, and as the reed packed in each succeeding fill yarn, the loops became crimped and would break. Additional weights to the warp yarn of the top and bottom face sheets increased the tension of these yarns as expected and eliminated the forming of loops. However, the yarn tension was excessive, and during the locking sequence of the

Table 3-1

TARGET CHARACTERISTICS AND DIMENSIONS OF ITEMS 3, 4, AND 5 NEXTEL 440 TABI FABRICS

FABRIC YARN COUNT	TARGET VALUES		
	ITEM 3	ITEM 4	ITEM 5
TOP FACE (WARP X FILL)			
ENDS/cm X PICKS/cm	10.2 X 10.2	10.2 X 10.2	10.2 X 10.2
ENDS/inch X PICKS/inch	26.0 X 26.0	26.0 X 26.0	26.0 X 26.0
RIBS			
ENDS/cm X PICKS/cm	10.2 X 10.2	10.2 X 10.2	10.2 X 10.2
ENDS/inch X PICKS/inch	26.0 X 26.0	26.0 X 26.0	26.0 X 26.0
BOTTOM FACE			
ENDS/cm X PICKS/cm	10.2 X 10.2	10.2 X 10.2	10.2 X 10.2
ENDS/inch X PICKS/inch	26.0 X 26.0	26.0 X 26.0	26.0 X 26.0
FABRIC AREAL WEIGHT			
kgs./sq. meter	1.82	1.82	1.82
oz./sq. yard	53.68	53.68	53.68
PANEL AREAL WEIGHT (INCLUDING INSULATION)			
kgs./sq. meter	3.04	3.04	3.04
oz./sq. yard	89.68	89.68	89.68
FABRIC FACE THICKNESS			
TOP FACE			
cm	0.043	0.043	0.043
inch	0.017	0.017	0.017
BOTTOM FACE			
cm	0.043	0.043	0.043
inch	0.017	0.017	0.017
FLUTE HEIGHT (OR CELL HEIGHT)			
cm	1.27	1.27	1.27
inch	0.50	0.50	0.50
GROUND WIDTH			
cm	66.04	66.04	66.04
inch	26.00	26.00	26.00
EACH SELVAGE (TOP AND BOTTOM FACE)			
cm	2.54	2.54	2.54
inch	1.00	1.00	1.00

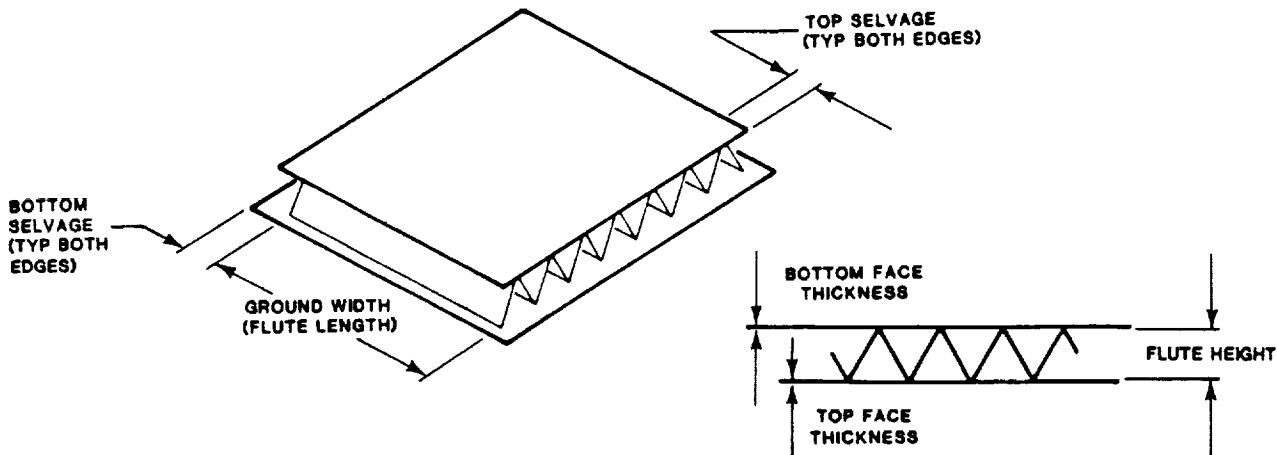



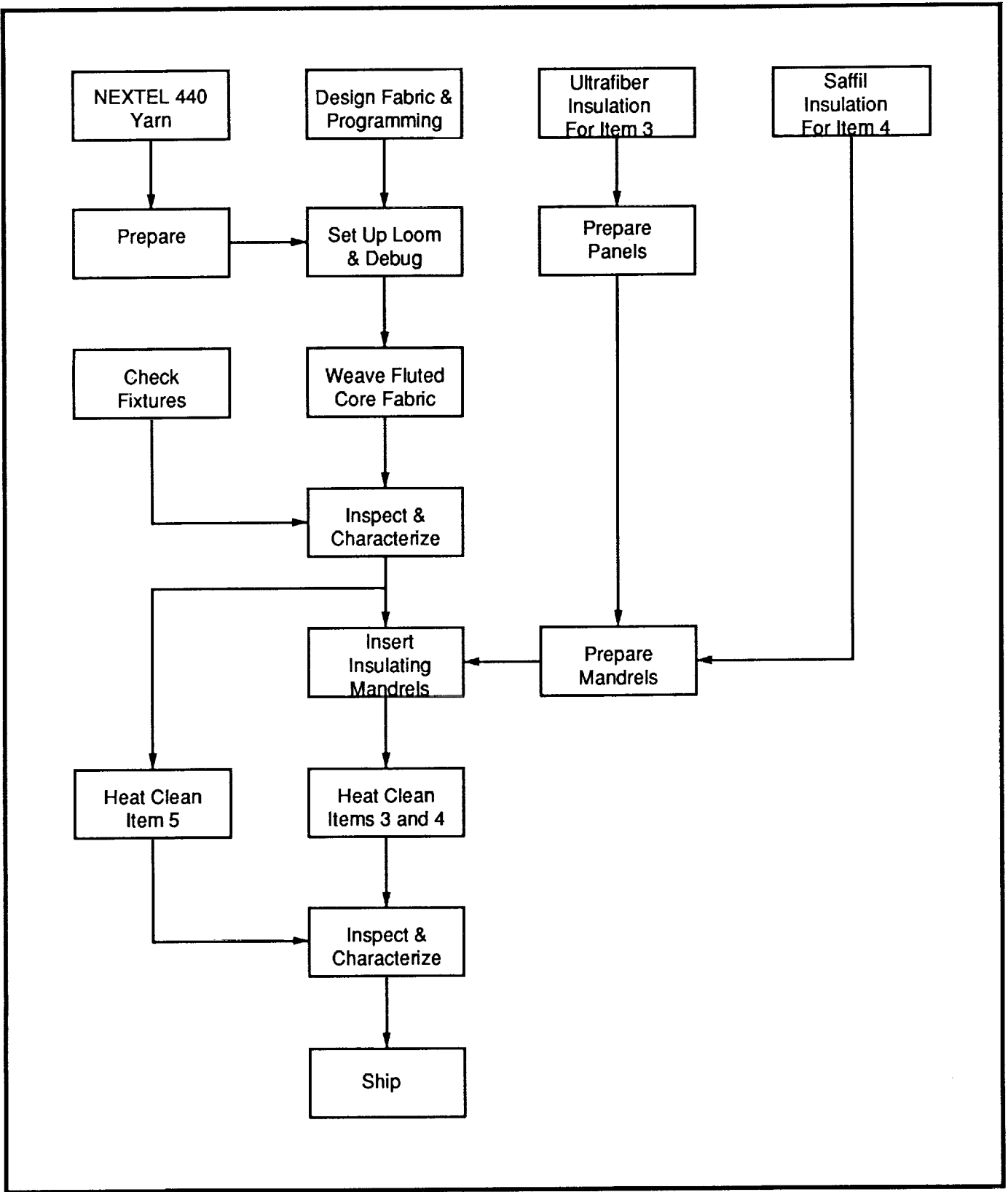

Figure 3-1

PROGRAM PLAN, ITEMS 3, 4 and 5

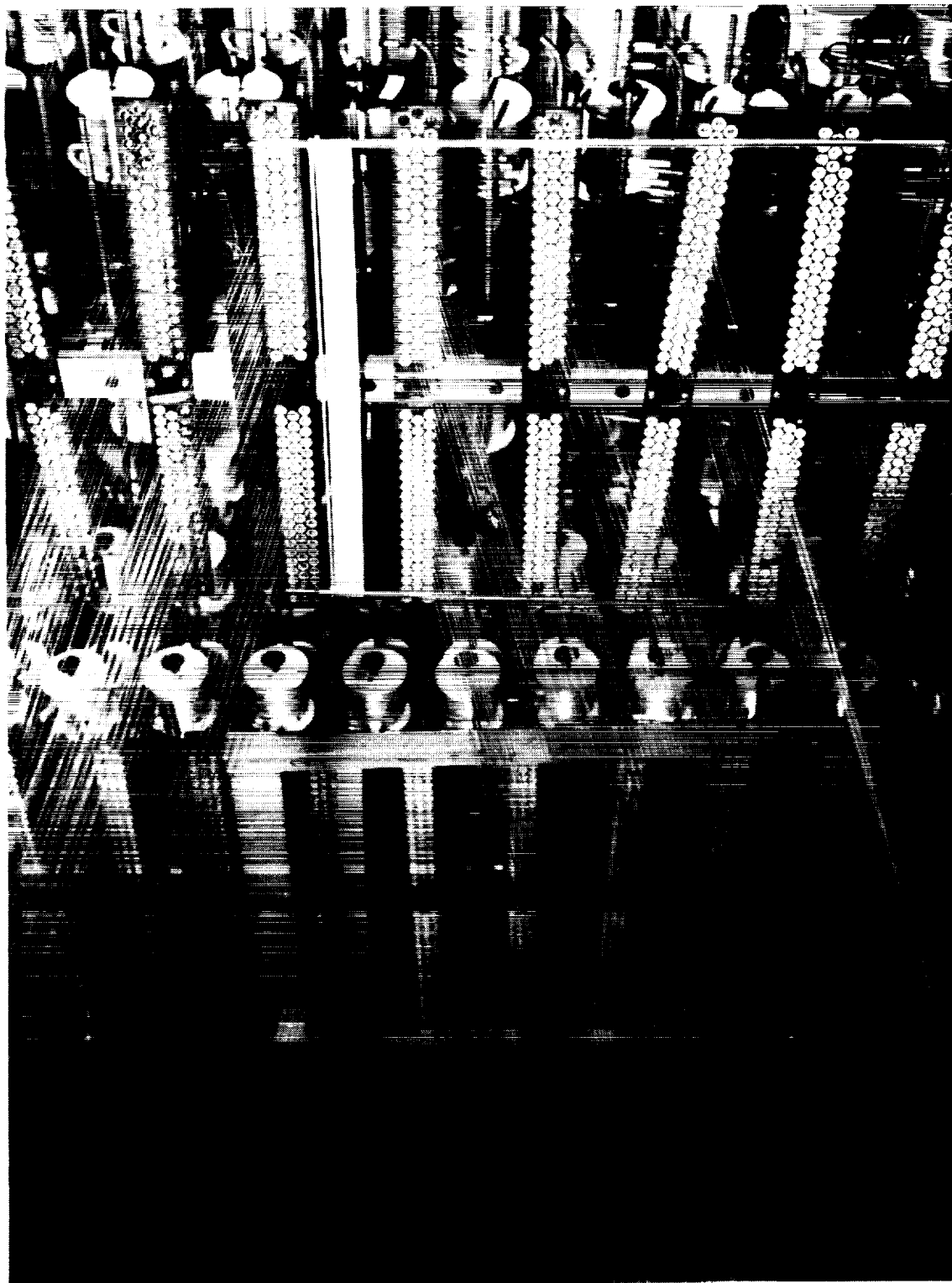

Figure 3-2  
CREEL SET-UP FOR NEXTEL TABI

ORIGINAL PAGE  
BLACK AND WHITE PHOTOGRAPH



Figure 3-3  
NEXTTEL 440 WARP ENTERING BACK OF LOOM

rib to the top or bottom faces, the warp yarns of the face sheets sheared. This situation was overcome by slightly reducing the tensioning weights on the warp spool packages.

At that point, shearing of rib fabric was experienced. This breakage was partly due to improper tensioning of the rib fabric and attempts were made to correct this problem by adjusting the warp yarn tensioning for the rib fabric. This proved to be unsuccessful. Further observation and analysis indicated that the crimping of the rib fabric occurred when weaving 4 consecutive picks of the rib without advancement of the fluted core fabric through the loom. Since the programmed weaving sequence did not allow for additional take-up, the 4 fill yarns were packed into the space of 1, forcing that portion of the rib fabric to crimp and break. Unlike graphite, Nextel AB 312, or served Nicalon SiC yarns which can withstand this bending, the Nextel 440 rib yarns appear to break when severely crimped. The crimped rib fabric is shown in Figure 3-4, and expanded fabric broken at the ribs is seen in Figure 3-5. Several approaches to resolve this problem were attempted.

- 3.2.3.2 The first involved altering the weaving sequence so that the take-up advancement of the fluted core fabric occurred after each fill insertion. This arrangement differs from the previous one in that the rib fabric advances with each pick. The original sequence did not allow the rib advancement, forcing the rib fabric to crimp when being woven. The amount of rib breakage was reduced considerably in the rib fabric area, yet breakage continued especially at the locks. The improvement led to incorporating this picking sequence in the weave design, which did not effect the construction of the fluted core fabric.

It was thought that the rib breakage could be further alleviated by releasing the rib tension for several picks when weaving the fluted core lock. The Nextel rib fibers are tensioned by a set of spring loaded lease bars. The loom was programmed to lift these lease bars from the rib yarns at the locking sequence to relax the rib fibers. Several cells were carefully woven producing an adequate lock and fewer broken rib yarns. Since the rib breakage remained, though to a lesser degree it was necessary to examine an alternative solution.

- 3.2.3.3 Another attempt to resolve the rib breakage involved substituting the existing Nextel 440 warp yarns with rayon served Nextel 440 fiber in two sections of the TABI fabric. In one section, the top and bottom face warp yarns were replaced with rayon served Nextel 440, while in another section only the rib fibers were rayon served. After weaving several inches, it was noticed that the Nextel warp fibers which were rayon served had not experienced any breakage while in other areas of the TABI fabric excessive rib breakage had occurred. It was then decided to single serve an adequate amount of Nextel 440 fiber for the rib yarn only. It was hoped that serving would adequately protect the Nextel rib yarn during weaving and enhance its lubricity. When weaving resumed, it appeared that the fabric had indeed improved. However, when a sample was removed from the loom, heat cleaned and examined, the breakage of the rib fabric due to crimping was still evident.

- 3.2.3.4 The final attempt to solve the breakage problem focused on trying to reduce the crimping action during weaving. The loom was originally equipped with a 10.1 cm (4 inch) diameter steel idler roll around which the multi-ply, newly woven fabric collapsed and was compressed as it was pulled by the take-up roll, Figure 2-4. This idler roll was replaced with a 20.3 cm (8 inch) diameter roll in order to distribute the take-up load over a larger area of fabric, Figure 3-6. To further minimize the collapsing and thus the crimping of the fabric, when weaving resumed, lengths of vinyl plastic tubing, 0.79 cm OD x 0.48 cm ID (0.31 in. x 0.19 in) were inserted into the flute openings before the fabric reached the new idler roll. Fabric woven in this manner did not fully collapse, and, as expected, was free of rib fabric shearing. Figure 3-7 shows the Nextel 440 TABI fabric woven with the tube inserts. Fabric in an expanded condition before and after heat cleaning, Figure 3-8, reveals that the rib fabric was intact and had not experienced shearing. While the

ORIGINAL PAGE  
BLACK AND WHITE PHOTOGRAPH



Figure 3-4  
NEXTEL 440 TABI FABRIC SHOWING CRIMPED  
RIBS

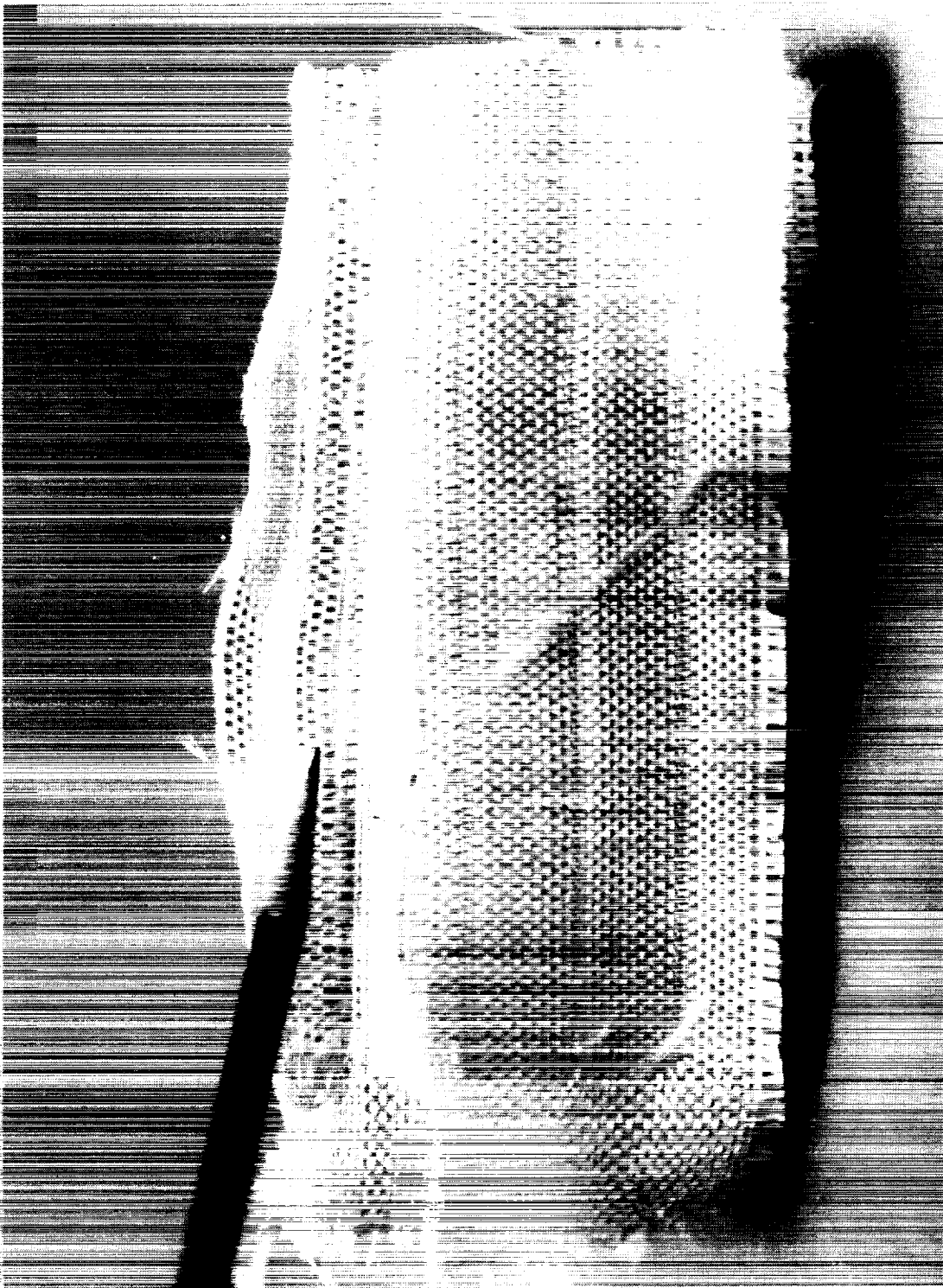

Figure 3-5  
NEXTEL 440 TABI FABRIC SHOWING SHEARED  
RIBS

ORIGINAL PAGE  
BLACK AND WHITE PHOTOGRAPH



Figure 3-6

LARGE DIAMETER IDLER ROLL



Figure 3-7  
NEXTEL 440 TABI FABRIC WITH VINYL TUBE  
INSERTS





Figure 3-8  
NEXTTEL 440 TABI FABRIC WOVEN WITH VINYL  
INSERTS

combination of the large idler roll and the vinyl tubing insertion were helpful in verifying and eliminating the crimping problem, the insertion of tubes into the flutes did not appear to be a practical solution to produce Nextel 440 TABI fabric on a continuous basis. At this point, all conceivable approaches to weave acceptable fabric were exhausted, and NASA was advised accordingly. Approximately 0.61 meters (2 feet) of this material was woven and Woven Structures agreed to insulate the fabric with Saffil before termination of the contract.

3.2.4 Insulation Preparation, Insertion and Heat Cleaning. Saffil mandrels were prepared similarly as for Items 1 and 2 and inserted into the flutes of the Nextel 440 fabric. The special insertion tool was used to insert the fragile mandrels. Approximately 45.7 lineal cm (18 in) of Nextel TABI fabric were insulated, Figure 3-9 and Figure 3-10, and then heat cleaned as previously described for Items 1 and 2.

3.2.5 Characterization. Measurements were made on representative available samples of fabric and insulated panels, and the results presented in Table 3-2. The areal weights of the fabric and insulated panels were lower than targeted values because the pick count was reduced to facilitate weaving. Prior to insulating, the fluted core fabric was inspected for proper cell dimensions using check mandrels. A snug fit of these mandrels indicated correct cell size.

#### 4.0 Health and Safety.

During the entire program, precautions were taken to minimize health risks presented by handling of the materials involved. Potential problems in scaling up to larger assemblies were also considered. Of all the materials, Nicalon required the most attention because of its high modulus and fragility. When working with silicon carbide yarns and fabrics, especially after heat cleaning, any contact by the hands, or other unprotected skin area, resulted in penetration of irritating SiC slivers. It was important for operators to avoid rubbing other areas of their bodies, especially their eyes. Nitrile rubber gloves were worn by operators during all processing steps that required contact with the Nicalon, from yarn preparation to packaging for shipping. Protective sleeves were worn to protect bare arms from exposure. The precautions taken greatly minimized the potential health hazards of handling silicon carbide fibers, and personnel involved with subsequent handling or fabricating should be aware of this hazard. While preparing both the Ultrafiber and Saffil insulations, dust and mist respirator masks, approved by NIOSH (National Institute for Occupational Safety and Health), were worn by personnel.

#### 5.0 SUMMARY AND CONCLUSIONS

5.1 Fluted core fabrics woven from Nicalon silicon carbide fiber and filled with Ultrafiber aluminoborosilicate and Saffil alumina fiber insulations to form TABI panels were successfully produced close to target requirements after solving minor start-up problems. Both insulation materials were suitable for making insertion mandrels, however the Saffil insulation proved to be more fragile. Insulation losses during insertion were minimized by using a special insertion tool. Cutting waste for both insulating materials was high because of the small mandrel cross section and the thick saw blade used for cutting the rigid panels.

5.2 Attempts to weave Nextel 440 fiber into fluted core fabric of the contract requirements were unsuccessful due to the yarn's high modulus and fragility. A very small quantity of fabric with pick counts below target requirements was finally produced by inserting plastic tubing in the flutes during weaving. This procedure minimized the crimping and resulting shearing of the rib fabric inside the flutes. A short TABI panel was made from this fabric using Saffil insulation. Nextel 440 1000 denier yarn does not appear to be a good candidate for weaving fluted core structures.

ORIGINAL PAGE  
BLACK AND WHITE PHOTOGRAPH



Figure 3-9  
NEXTTEL 440 TABI CROSS SECTION INSULATED  
WITH SAFFIL

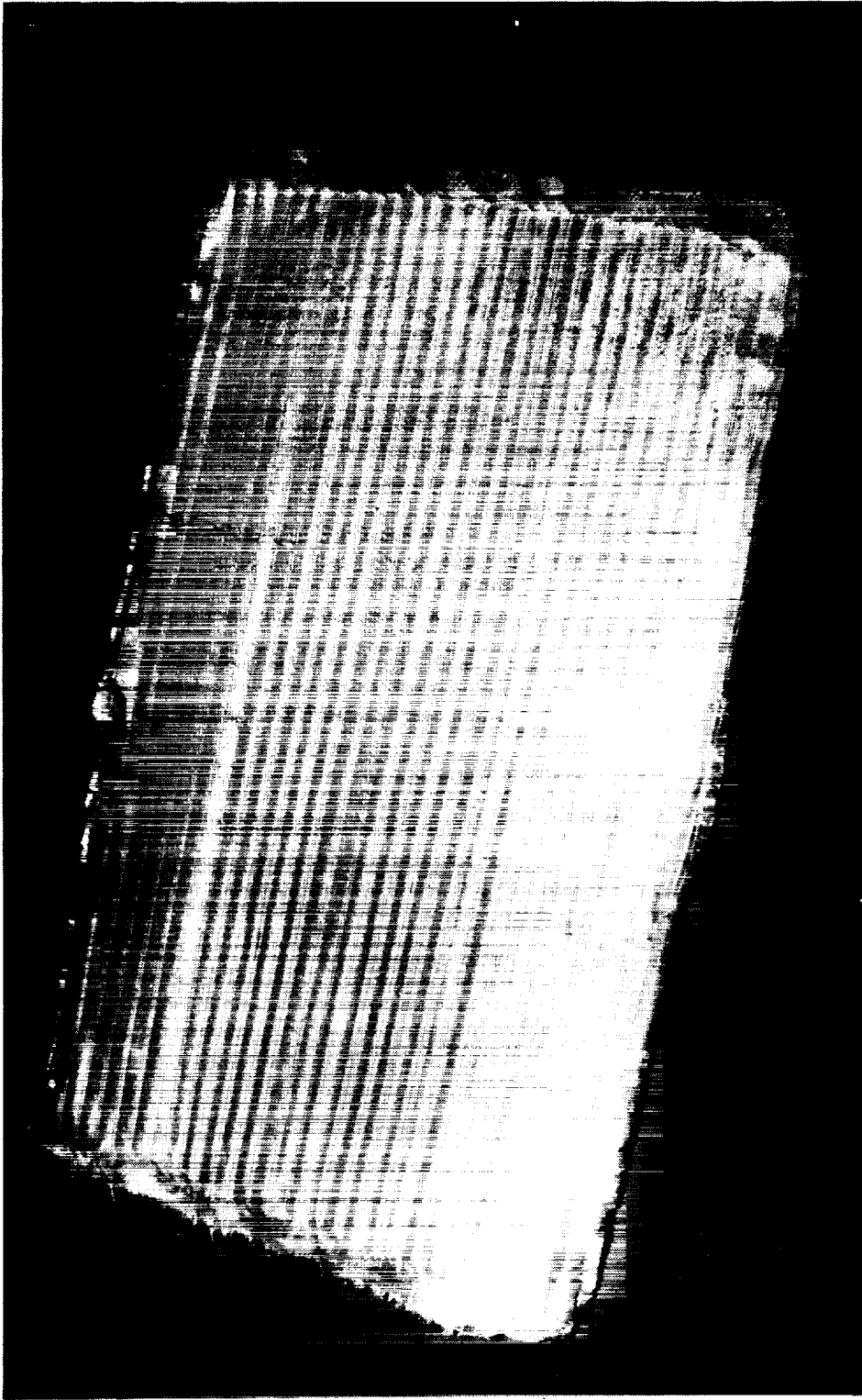
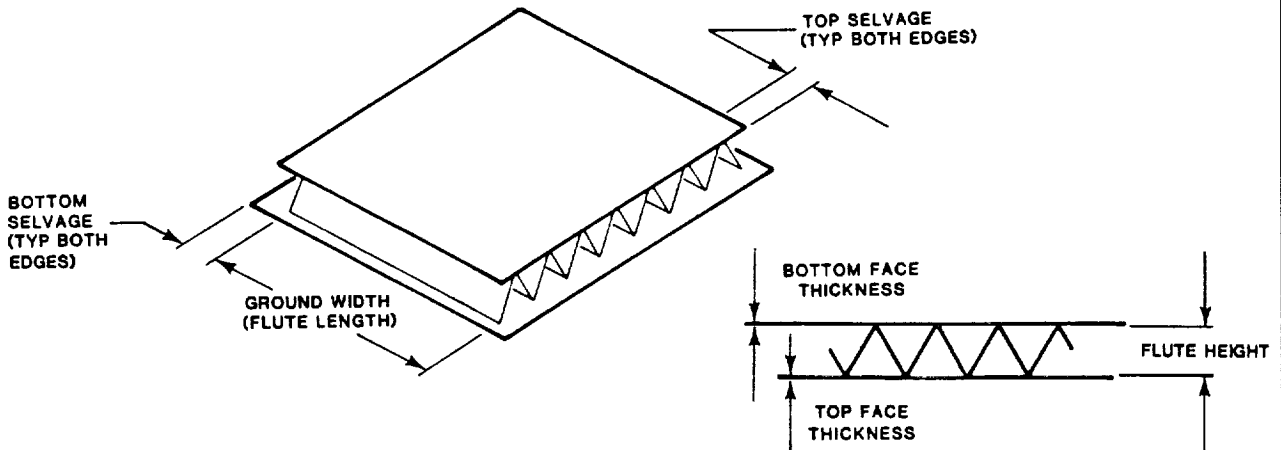

Figure 3-10  
HEAT CLEANED NEXTEL 440 TABI PANEL  
INSULATED WITH SAFFIL

Table 3-2

**ACTUAL CHARACTERISTICS AND DIMENSIONS  
OF ITEMS 4 AND 5 NEXTEL 440 TABI FABRICS**

FABRIC YARN COUNT	MEASURED VALUES	
	ITEM 4 SAFFIL	ITEM 5 UNFILLED
TOP FACE (WARP X FILL)		
ENDS/cm X PICKS/cm	10.4 X 8.30	10.4 X 8.30
ENDS/inch X PICKS/inch	26.5 X 21.0	26.5 X 21.0
RIBS		
ENDS/cm X PICKS/cm	10.4 X 7.90	10.4 X 7.90
ENDS/inch X PICKS/inch	26.5 X 20.0	26.5 X 20.0
BOTTOM FACE		
ENDS/cm X PICKS/cm	10.4 X 8.30	10.4 X 8.30
ENDS/inch X PICKS/inch	26.5 X 21.0	26.5 X 21.0
FABRIC AREAL WEIGHT		
kgs./sq. meter	1.67	1.67
oz./sq. yard	49.18	49.18
PANEL AREAL WEIGHT (INCLUDING INSULATION)		
kgs./sq. meter	2.98	--
oz./sq. yard	87.77	--
FABRIC FACE THICKNESS		
TOP FACE		
cm	0.046	0.046
inch	0.018	0.018
BOTTOM FACE		
cm	0.046	0.046
inch	0.018	0.018
FLUTE HEIGHT (OR CELL HEIGHT)		
cm	1.32	1.32
inch	0.52	0.52
GROUND WIDTH		
cm	67.95	67.95
inch	26.75	26.75
EACH SELVAGE (TOP AND BOTTOM FACE)		
cm	2.54	2.54
inch	1.00	1.00



6.0 Recommendations

6.1 Recommendations to be considered for future efforts are as follows:

1) Insulation

- a) Saffil. Saffil panels made with a higher binder content or with different types of organic binders should be evaluated to increase the rigidity and strength of insulation mandrels. Processes to rigidize batting resulting in minimum fiber degradation should be developed.
- b) Ultrafiber. Stitchbonding of the insulation causes damage to the batting and resulting mandrels. It should be a primary concern to evaluate batting processed by adhesive bonding. This would eliminate stitching voids as well as fiber damage.

- 2) Mandrels. Alternate cutting techniques for rigid panels should be explored to reduce the large material losses (about 30%) when making mandrels. Thinner circular blades, wire saws and knife blades should be evaluated.

7.0

List of Appendices

- A. Manufacturer's Literature and Material Safety Data Sheet for Nicalon Yarn.
- B. Manufacturer's Literature and Material Safety Data Sheet for Nextel 440 Yarn.
- C. Manufacturer's Literature for Nextel 440 Ultrafiber Insulation.
- D. Manufacturer's Literature and Material Safety Data Sheet for Saffil Products.





APPENDIX A

Manufacturer's Literature and Material Safety Data  
Sheets for Nicalon

PRECEDING PAGE BLANK NOT FILMED



# New Product Information

## DESCRIPTION

NICALON® fiber is a new type of silicon carbide fiber manufactured through a polymer pyrolysis process by Nippon Carbon Co., Ltd., of Japan. It is homogeneously composed of ultrafine  $\beta$ -SiC crystals with excess carbon. The fiber has excellent strength and modulus properties. It retains its properties at high temperatures. NICALON fiber is highly resistant to oxidation and chemical attack. The fiber is readily wet by organic resins and metals.

## USES

NICALON fiber can be used as a reinforcement for plastic, metal and ceramic matrices to form high performance composite materials. It can also be used to form fibrous products such as high temperature insulation, belting, curtains, gaskets, etc. Its resistance to chemical attack allows it to be used in highly corrosive environments.

"NICALON" is a registered trademark of Nippon Carbon Co., Ltd., Japan

## NICALON® SILICON CARBIDE FIBERS

Type.....	Silicon carbide
Physical Form.....	Fiber
Primary Uses.....	Reinforcement for plastic, metal or ceramic matrices; to form fibrous material

## NOMINAL PROPERTIES OF NICALON FIBER

These values are not intended for use in preparing specifications.

Filament Diameter.....	10~20 $\mu$ m
Cross Section.....	Round
Filaments Tow.....	500
Count.....	200 tex
Density.....	0.092-0.094 lb/in <sup>3</sup> (2.55-2.56 g/cm <sup>3</sup> )
Tensile Strength.....	360~470 ksi (250~330 kg/mm <sup>2</sup> )
Tensile Modulus.....	26~29 $\times 10^3$ ksi (18~20 $\times 10^3$ kg/mm <sup>2</sup> )
Strain to Failure.....	1.5% Average
Thermal Conductivity.....	10 Kcal mhr °C (Along fiber axis @ RT)
Specific Resistivity.....	$\sim 10^3$ ohm cm
Coefficient of Thermal Expansion.....	3.1 $\times 10^{-6}$ °C (Along fiber axis, 0-200°C)

**Specification Writers: Please contact Dow Corning Corporation, Midland, Michigan, before writing specifications on this product.**

PRECEDING PAGE BLANK NOT FILMED

**GRAPH 1: TENSILE STRENGTH OF NICALON FIBER**

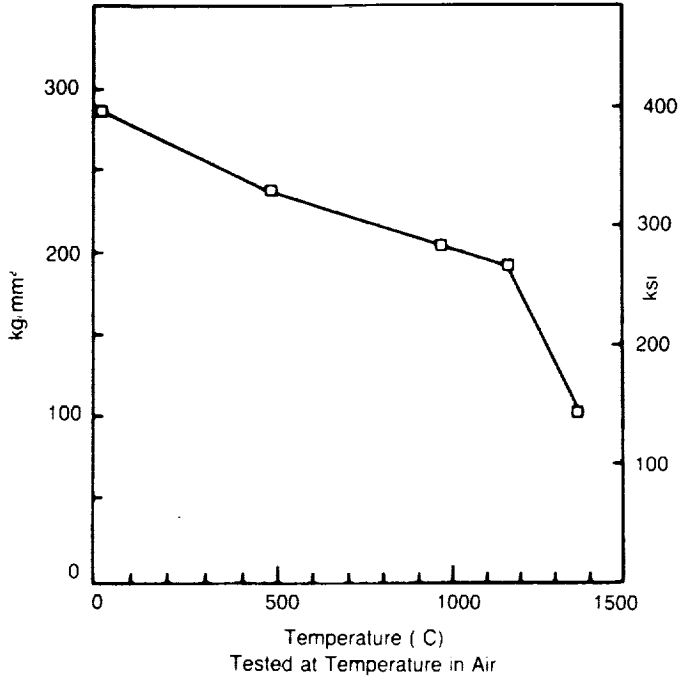

**GRAPH 2: TENSILE STRENGTH OF NICALON FIBER AFTER HEAT TREATMENT**

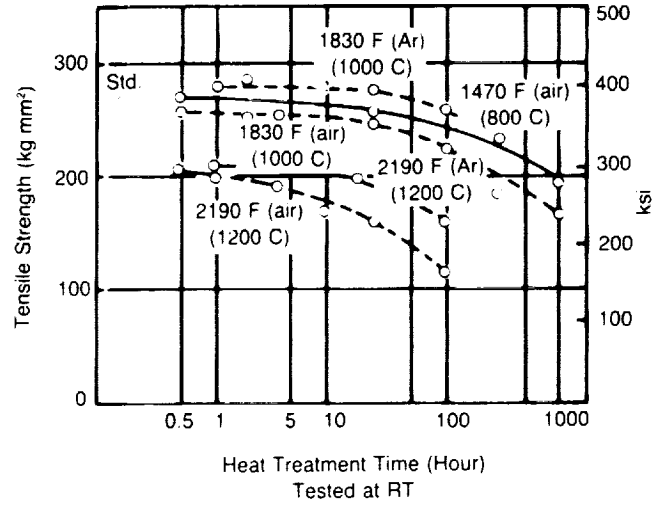

**Ceramic Matrix Composites**

NICALON silicon carbide fiber should be considered as a reinforcement for ceramic matrices. Its combination of high strength, high modulus, low density, oxidation resistance, chemical resistance and retention of properties at high temperatures make it ideal for ceramic composites to be used in severe environments.

Present work in NICALON fiber glass composites has shown encouraging results. NICALON fiber could potentially be used to form oxidation resistant composites. (See Table 1.)

**TABLE 1: PROPERTIES OF 50 VOL % NICALON FIBER REINFORCED LITHIUM ALUMINUM SILICATE (LAS) COMPOSITES**

Property	0°	0° 90°
Density (g cm <sup>-3</sup> )	2.5	2.5
Flexural Strength (MPa)		
RT	600	380
800°C (1472°F)	800	410
1000 C (1832°F)	850	480
Fracture Toughness - K <sub>1C</sub> (MN m <sup>3/2</sup> )		
RT	17	10
1000°C (1832°F)	25	12
Thermal Expansion (10 <sup>-6</sup> C <sup>-1</sup> )	2.2	1.6 (90°)
Thermal Conductivity		
(cal sec <sup>-1</sup> cm <sup>-1</sup> °C <sup>-1</sup> )	3.5 × 10 <sup>-1</sup>	3.5 × 10 <sup>-1</sup>
(W m <sup>-1</sup> K <sup>-1</sup> )	1.465	1.465

Source: Karl M. Prewé, John J. Brennan, *J. Mat. Sci.*, XVII, (1982), 2371-2383

### Plastic Matrix Composites

NICALON fiber may be utilized to reinforce plastic matrix materials. The fiber is nonelectrically conductive so corrosion of metals is not enhanced when in contact with its composites nor should electrical grounding problems arise from free fibers. NICALON fiber/epoxy composites show improved compressive, impact and interlaminar shear strength and thermal expansion compatibility over common graphite/epoxy composites. The unique electrical properties of NICALON fiber may lead to specialized aerospace applications. The oxidation resistance of NICALON fiber makes it a candidate for high temperature plastic composites. (See Tables 2 and 3.)

### Metal Matrix Composites

NICALON fiber is an excellent choice as a reinforcement for metal matrix composites. The fiber is readily wet by metals. The fiber can easily be woven into cloth and preformed shapes. This allows composite design and manufacturing methods to be tailored to best suit potential applications. NICALON fiber's good specific strength and modulus, and the retention of these properties as high temperatures, result in improved metal composite properties. Since the fiber is nonelectrically conductive it does not enhance metal corrosion. NICALON chopped fiber used as discontinuous reinforcement for metals could enable composites to be postformed by conventional metal-working techniques. (See Table 4.)

**TABLE 2: TYPICAL PROPERTIES OF NICALON FIBER/EPOXY RESIN COMPOSITES\***

Tensile Strength(0°)	215 ksi (150 kg/mm <sup>2</sup> )
Tensile Modulus	18.5 × 10 <sup>3</sup> ksi (13 × 10 <sup>3</sup> kg/mm <sup>2</sup> )
Flexural Strength (0°)	285 ksi (200 kg/mm <sup>2</sup> )
Flexural Modulus	17.1 × 10 <sup>3</sup> ksi (12 × 10 <sup>3</sup> kg/mm <sup>2</sup> )
Compressive Strength	257 ksi (180 kg/mm <sup>2</sup> )
Interlaminar Shear Strength	17.1 ksi (12 kg/mm <sup>2</sup> )
Charpy Impact Strength	1450 lb-in/in <sup>2</sup> (260 kg-m <sup>2</sup> /mm <sup>2</sup> )
Coefficient of Thermal Expansion,	
(0°)	2.6 × 10 <sup>-6</sup> /°C
(90°)	20 × 10 <sup>-6</sup> /°C
Density	0.073 lb/in <sup>3</sup> (2.0 g/cm <sup>3</sup> )

\*Shell DX 210 epoxy, 60 v o fiber.

**TABLE 3: TYPICAL NICALON 8 HARNESS SATIN/POLYIMIDE COMPOSITE PROPERTIES**

	SHELL DX 210 EPOXY	POLYIMIDE
Fiber Volume Fraction, %	45	45
Density, g/cc	1.80	1.85
Tensile Strength, kg/mm <sup>2</sup>	57	52
Flexural Strength, kg/mm <sup>2</sup>	95	92
I.L.S.S., kg/mm <sup>2</sup>	6.7	5.6

**TABLE 4: TYPICAL PROPERTIES OF NICALON FIBER/UNIDIRECTIONALLY REINFORCED 1100 ALUMINUM COMPOSITES (V<sub>f</sub> = 35%)**

Tensile Modulus (0°) <sup>1)</sup>	14~16 × 10 <sup>3</sup> ksi (10~11 × 10 <sup>3</sup> kg/mm <sup>2</sup> )
Tensile Strength	
(0°)	114~129 ksi (80~90 kg/mm <sup>2</sup> )
(90°) <sup>2)</sup>	10~11 ksi (7~8 kg/mm <sup>2</sup> )
Flexural Strength <sup>3)</sup>	143~157 ksi (100~110 kg/mm <sup>2</sup> )
Flexural Fatigue Strength (10 <sup>7</sup> cycle)	57 ksi (40 kg/mm <sup>2</sup> )
Coefficient of Thermal Expansion <sup>4)</sup>	
(0°)	3.2 × 10 <sup>-6</sup> /°C
(90°)	25 × 10 <sup>-6</sup> /°C
Density	0.095 lb/in <sup>3</sup> (2.6 g/cm <sup>3</sup> )
Poisson Ratio	0.18

<sup>1)</sup>Fiber axis direction.

<sup>2)</sup>Perpendicular direction to fiber axis.

<sup>3)</sup>Three-point method

<sup>4)</sup>212~392°F (100~200°C)

0013, 1987

05/286 (60)  
AP017047 05/286 (W)

Inspection Sheet of SiC Fiber "NICALON"

To Messrs. Dow Corning Corporation

- 1. Product identification: Ceramic Grade NLP-201
- 2. Quantity: 100 Kg (59.4Kg)
- 3. Date of manufacture: Apr. 1986
- 4. Date of shipment: Apr. 1986
- 5. PO number: 65622
- 6. Lot number: 048 049 052 035
- 7. Spool number: 601749 601983 602110 602143  
 ~601982 ~602052 ~602142 ~602342  
 602053 602063  
 ~602062 ~602109

8. Specification:	Inspection date
Filaments/yarn : 500	Apr. 1986
Length of yarn : 500m	
Weight percent of sizing resin : 1.5±0.5%	

9. Test data:

Test identification \ Lot No.	048	049	052	035
Tex count (gr/1000m)	204	202	206	207
Tensile Strength†(ksi)	448	431	473	374
(kg/mm <sup>2</sup> )	314	302	331	262
Tensile Modulus† (×1000 ksi)	28.3	27.8	27.4	29.0
(×1000 kg/mm <sup>2</sup> )	19.8	19.5	19.2	20.3
Density (g/cm <sup>3</sup> )	2.55	2.55	2.55	2.55
Oxygen content (%)	10.8	10.3	10.9	11.4

† By resin impregnated strand method (JIS R 7001, ASTM D 2344, AMS 3892)

by T. Kobayashi  
T. Kobayashi Manager

4/28/1986

## Inspection Sheet of SiC Fiber "NICALON"

To Messrs. Dow Corning Corporation

1. Product identification: Ceramic Grade NLP-201
2. Quantity: 100 kg (40.6kg)
3. Date of manufacture: Apr. 1986
4. Date of shipment: Apr. 1986
5. PO number: 65622
6. Lot number: 032    033B    038B    044    046    046B
7. Spool number: 601343    601415    601467    601623    601676    601717  
                   ~601414    ~601466    ~601622    ~601675    ~601716    ~601748

8. Specification:	Inspection date
Filaments/yarn : 500	Apr. 1986
Length of yarn : 500m	
Weight percent of sizing resin : 1.5±0.5 %	

9. Test data:

Test identification \ Lot No.	032	033B	038B	044	046	046B
Tex count (gr/1000m)	206	205	200	200	208	200
Tensile Strength†(ksi)	410	408	390	390	430	410
(kg/mm <sup>2</sup> )	287	286	273	273	301	287
Tensile Modulus† (×1000 ksi)	28.8	29.0	28.6	27.4	27.3	28.3
(×1000 kg/mm <sup>2</sup> )	20.2	20.3	20.0	19.2	19.1	19.8
Density (g/cm <sup>3</sup> )	2.55	2.55	2.55	2.55	2.55	2.55
Oxygen Content (%)	11.1	10.8	11.0	9.7	10.4	10.4

† by resin impregnated strand method (JIS R 7601, ASTM D 2344, AMS 3892)

by T. Kobayashi  
 T. Kobayashi    Manager

4/28/1986

F-022

SEP 29 1977

MATERIAL SAFETY DATA SHEET

MATL NAME: NICALON(R) CONTINUOUS FIBER P  
EMERGENCY TELEPHONE NO. (517) 496-5900

SECTION I - GENERAL INFORMATION

MANUFACTURERS NAME: DOW CORNING CORPORATION  
ADDRESS: SOUTH SAGINAW ROAD, MIDLAND MI 48686

PROPER SHIPPING NAME(49CFR 172.101): NONE  
D.O.T. HAZARD NAME(49CFR 172.101): NONE  
D.O.T. ID NO(49CFR 172.101): NONE  
D.O.T. HAZARD CLASS(49CFR 172.101): NONE  
RCRA HAZARD CLASS(40CFR 261)(IF DISCARDED): NONE  
E.P.A. PRIORITY POLLUTANTS(40CFR 122.53): NONE  
NFPA = NATIONAL FIRE PROTECTION ASSOCIATION - 704  
HEALTH (NFPA): 1 FLAMMABILITY (NFPA): 0 REACTIVITY (NFPA): 0  
CAS NO: ARTICLE DOW CORNING WARNING CODE: 48,33,62  
GENERIC DESCRIPTION: SILICON CARBIDE

SECTION II - HAZARDOUS INGREDIENT

SILICON CARBIDE	% 100	TLV (UNITS): 10 MG/M3 TOTAL
.	%	TLV (UNITS): DUST; PEL
.	%	TLV (UNITS): 15 MG/M3

ONLY THOSE INGREDIENTS LISTED IN THIS SECTION HAVE BEEN DETERMINED TO BE HAZARDOUS AS DEFINED IN 29 CFR 1910.1200. AN INGREDIENT MARKED WITH AN ASTERISK(\*) IS ALSO LISTED IN 29 CFR 1910.1200(D) #4 AS KNOWN OR SUSPECTED CARCINOGEN.

COMMENT: TLV APPLIES TO ANY DUST ASSOCIATED WITH THE PRODUCT'S PHYSICAL FORM, AS SUPPLIED, OR TO DUST CREATED DURING HANDLING.



MATERIAL SAFETY DATA SHEET

F-022

MATL NAME: NICALON(R) CONTINUOUS FIBER P

SECTION III - EFFECTS OF OVEREXPOSURE

EYES: MECHANICAL IRRITATION MAY RESULT FROM PARTICLES OR DUST IN EYE AND SUBSEQUENT RUBBING.

SKIN: MAY CAUSE SLIGHT IRRITATION FROM SHARP FIBERS. DUST IS NOT LIKELY TO IRRITATE.

INHALATION: DUST MAY IRRITATE NOSE AND THROAT. PROLONGED OR FREQUENTLY REPEATED EXPOSURES MAY INJURE SLIGHTLY.

ORAL: AMOUNTS TRANSFERRED TO THE MOUTH BY FINGERS, ETC., DURING NORMAL OPERATIONS SHOULD NOT CAUSE INJURY.

COMMENT: POTENTIAL CHRONIC (LONG-TERM) EFFECTS OF INHALING FIBERS AND DUSTS OF THIS PRODUCT HAVE NOT BEEN DETERMINED THOROUGHLY. AVOID UNNECESSARY INHALATION EXPOSURE. ALSO SEE SECTION X COMMENTS. THIS PRODUCT, AS WITH ANY CHEMICAL, MAY ENHANCE ALLERGIC CONDITIONS ON CERTAIN PEOPLE. WE DO NOT KNOW OF ANY MEDICAL CONDITIONS THAT MIGHT BE AGGRAVATED BY EXPOSURE TO THIS PRODUCT.

SECTION IV - EMERGENCY AND FIRST AID PROCEDURES

EYES: IMMEDIATELY FLUSH WITH WATER. GET MEDICAL ATTENTION IF DISCOMFORT PERSISTS.

SKIN: GENTLY BRUSH AWAY ANY DUST, PARTICLES, OR FIBERS AND FLUSH WITH WATER.

INHALATION: REMOVE TO FRESH AIR. IF DISCOMFORT PERSISTS, GET MEDICAL ATTENTION. TYPICALLY, SHOULD NOT NEED FIRST AID EXCEPT FOR SEVERE OVEREXPOSURES.

ORAL: GET MEDICAL ATTENTION IF LARGE AMOUNTS SWALLOWED-NOT TYPICALLY AN OVEREXPOSURE ROUTE.

COMMENT: NONE.

SECTION V - FIRE AND EXPLOSION DATA

FLASH POINT (METHOD USED): OPEN/CLOSED - NONE

AUTOIGNITION: NONE

FLAMMABILITY LIMITS IN AIR : LOWER:N.A. UPPER: N.A.

EXTINGUISHING MEDIA: WATER WATER FOG X CO2 X DRY CHEMICAL X FOAM X OTHER

SPECIAL FIRE FIGHTING PROCEDURES: SELF-CONTAINED BREATHING APPARATUS AND PROTECTIVE CLOTHING SHOULD BE WORN IN FIGHTING FIRES INVOLVING CHEMICALS

UNUSUAL FIRE AND EXPLOSION HAZARDS: NONE KNOWN TO DOW CORNING.

COMMENTS: N.A. - NOT APPLICABLE.

SECTION VI - PHYSICAL DATA

BOILING POINT(@ 760 MM HG): NOT APPLICABLE

SPECIFIC GRAVITY (AT 77 DEG F/25 DEG C): ABOVE 1

MELTING POINT: NOT DETERMINED

VAPOR PRESSURE (AT 77 DEG F/25 DEG C): NOT APPLICABLE

VAPOR DENSITY (AIR = 1 AT 77 DEG F/25 DEG C): NOT APPLICABLE

PERCENT VOLATILE BY VOLUME (%): NOT APPLICABLE

EVAPORATION RATE (ETHER = 1): NOT APPLICABLE

SOLUBILITY IN WATER(%): INSOLUBLE

ODOR, APPEARANCE, COLOR: NO ODOR, THREAD-LIKE FIBER, DARK COLOR.

NOTE: THE ABOVE INFORMATION IS NOT INTENDED FOR USE IN PREPARING PRODUCT SPECIFICATIONS. CONTACT DOW CORNING BEFORE WRITING SPECIFICATIONS

F-022

MATERIAL SAFETY DATA SHEET

MATL NAME: NICALON(R) CONTINUOUS FIBER P

SECTION VII - REACTIVITY DATA

STABILITY: STABLE

INCOMPATIBILITY(MATERIAL TO AVOID): OXIDIZING MATERIAL CAN CAUSE A REACTION.

CONDITIONS TO AVOID: NOT APPLICABLE

HAZARDOUS DECOMPOSITION PRODUCTS: NONE

HAZARDOUS POLYMERIZATION: WILL NOT OCCUR

CONDITIONS TO AVOID: NOT APPLICABLE

COMMENTS: NONE

SECTION VIII - SPILL, LEAK AND DISPOSAL PROCEDURES

STEPS TO BE TAKEN IN CASE MATERIAL IS RELEASED OR SPILLED: SWEEP UP MATERIAL TO COLLECT AND CONTAIN FOR SALVAGE OR DISPOSAL. AVOID GENERATING AIRBORNE DUSTS.

PROTECTIVE EQUIPMENT:

EYES: USE PROPER PROTECTION -- SAFETY GLASSES, AS A MINIMUM.

SKIN: WASHING AT MEALTIME AND END OF SHIFT IS ADEQUATE.

INHALATION: USE RESPIRATORY PROTECTION UNLESS LOCAL EXHAUST VENTILATION IS ADEQUATE OR AIR SAMPLING DATA SHOW EXPOSURES ARE WITHIN TLV AND PEL GUIDELINES.

WASTE DISPOSAL METHOD: DOW CORNING SUGGESTS THAT ALL LOCAL, STATE AND FEDERAL REGULATIONS CONCERNING HEALTH AND POLLUTION BE REVIEWED TO DETERMINE APPROVED DISPOSAL PROCEDURES. CONTACT DOW CORNING IF THERE ARE ANY DISPOSAL QUESTIONS.

D.O.T. (49CFR 171.8)/E.P.A. (40CFR 117) SPILL REPORTING INFORMATION  
HAZARDOUS SUBSTANCE: NONE REPORTABLE QUANTITY: NOT APPLICABLE  
CONCENTRATION OF HAZARDOUS SUBSTANCE: NOT APPLICABLE  
REPORTABLE QUANTITY OF PRODUCT: NOT APPLICABLE

COMMENTS: NONE

SECTION IX - ROUTINE HANDLING PRECAUTIONS

PROTECTIVE EQUIPMENT:

EYES: USE PROPER PROTECTION -- SAFETY GLASSES, AS A MINIMUM.

SKIN \*: WASHING AT MEALTIME AND END OF SHIFT IS ADEQUATE.

INHALATION: USE RESPIRATORY PROTECTION UNLESS LOCAL EXHAUST VENTILATION IS ADEQUATE OR AIR SAMPLING DATA SHOW EXPOSURES ARE WITHIN TLV AND PEL GUIDELINES.

VENTILATION:

LOCAL EXHAUST: RECOMMENDED.  
MECHANICAL (GENERAL): NONE

SUITABLE RESPIRATOR: DUST TYPE.

THESE PRECAUTIONS ARE FOR ROOM TEMPERATURE HANDLING, USE AT ELEVATED TEMPERATURE MAY REQUIRE ADDED PRECAUTIONS.

\* GOOD PRACTICE REQUIRES THAT GROSS AMOUNT OF ANY CHEMICAL BE REMOVED FROM THE SKIN AS SOON AS PRACTICAL, ESPECIALLY BEFORE EATING OR SMOKING.  
COMMENTS: USE GOOD HOUSEKEEPING PRACTICES TO CONTROL POSSIBLE DUST PROBLEM.  
AVOID BREATHING DUST.

MATERIAL SAFETY DATA SHEET

E-022

MATL NAME: NICALON(R) CONTINUOUS FIBER P

SECTION X - SPECIAL PRECAUTIONS

PRECAUTIONS TO BE TAKEN IN HANDLING AND STORING: USE REASONABLE CARE AND CAUTION.

OTHER PRECAUTIONS: KNOWN HAZARDS RESULT MAINLY FROM DUST DURING HANDLING AND USE.

COMMENTS: LIMITED TOXICITY DATA SUGGEST INHALATION HAZARDS ARE SLIGHT. PARTICLES OR FIBERS FROM NORMAL HANDLING ARE TOO LARGE TO POSE A SIGNIFICANT INHALATION RISK. HOWEVER, IF PROCESSING, SUCH AS GRINDING OR MILLING, FORMS LARGE AMOUNTS OF DUST OF SMALLER, EASILY BREATHED PARTICLES, SOME LUNG INJURY MAY OCCUR.

THESE DATA ARE OFFERED IN GOOD FAITH AS TYPICAL VALUES AND NOT AS A PRODUCT SPECIFICATION. NO WARRANTY, EITHER EXPRESSED OR IMPLIED, IS HEREBY MADE. THE RECOMMENDED INDUSTRIAL HYGIENE AND SAFE HANDLING PROCEDURES ARE BELIEVED TO BE GENERALLY APPLICABLE. HOWEVER, EACH USER SHOULD REVIEW THESE RECOMMENDATIONS IN THE SPECIFIC CONTEXT OF THE INTENDED USE AND DETERMINE WHETHER THEY ARE APPROPRIATE.

PREPARED BY: JACK L. SHENEBERGER  
LAST REVISION DATE: JANUARY 02, 1987  
PREVIOUS REVISION DATE: OCTOBER 11, 1985  
DATE: SEPTEMBER 23, 1987

(R) INDICATES REGISTERED OR TRADEMARK OF THE DOW CORNING CORPORATION.



APPENDIX B

Manufacturer's Literature and Material Safety Data  
Sheet for Nextel 440 Yarn

~~ORIGINAL PAGE~~  
~~BLACK AND WHITE PHOTOGRAPH~~

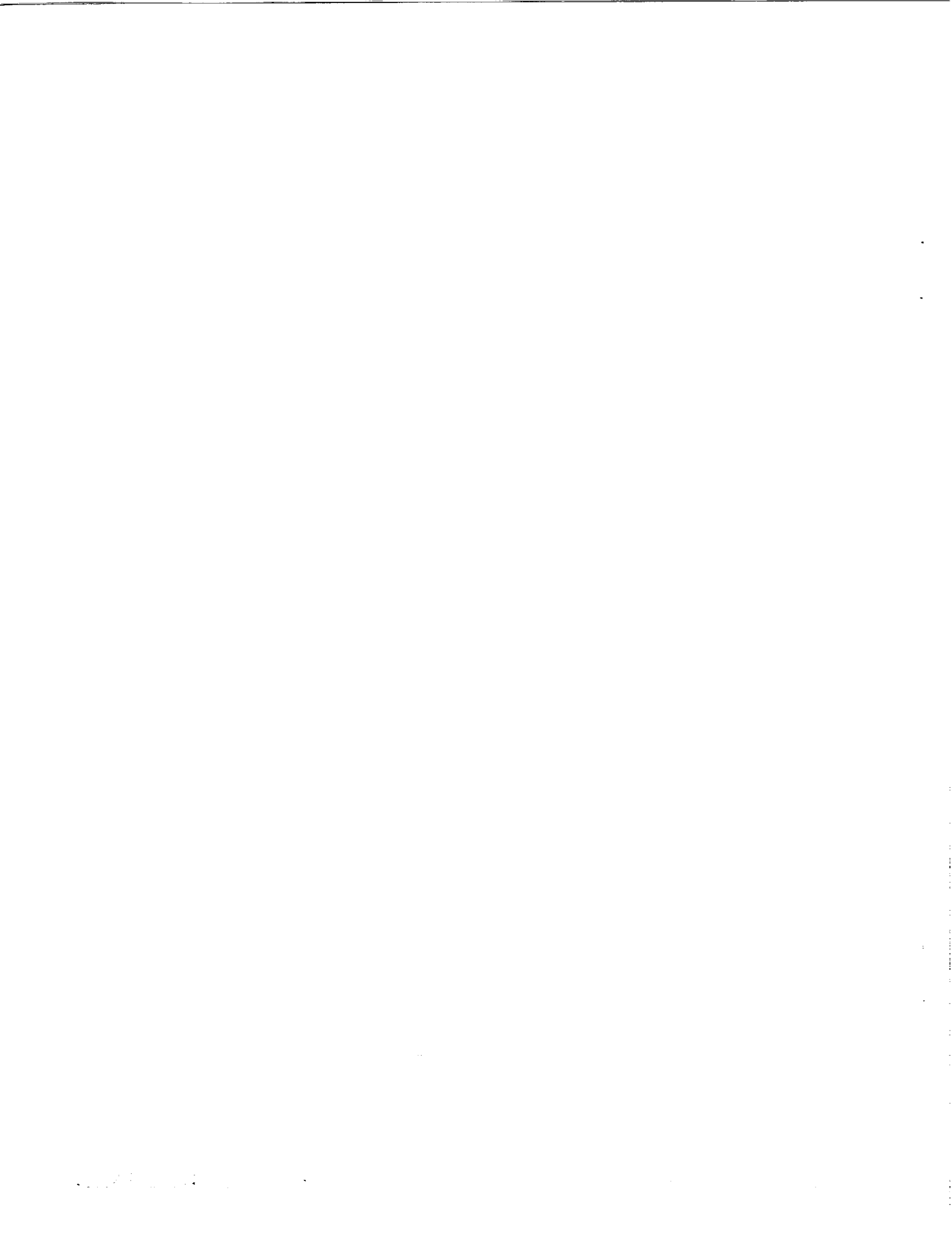

# Nextel® 440 Ceramic Fiber

Technical Bulletin

Nextel® 440 Ceramic Fibers are continuous polycrystalline metal oxide fibers suitable for producing textiles without the aid of other fiber or metal inserts. The fibers are composed of (by weight) 70% aluminum oxide (Al<sub>2</sub>O<sub>3</sub>), 28% silicon dioxide (SiO<sub>2</sub>), and 2% boron oxide (B<sub>2</sub>O<sub>3</sub>). Products made with Nextel 440 fibers retain strength and flexibility up to 1371°C (2500°F).

## Typical Applications Include:

- Radomes
- Structural Reinforcement
- Fire Barriers
- Vacuum Furnace Linings
- Zone Dividers
- Flexible Covers

## Filament Properties

Color	White
Length	Continuous
Tensile Strength	300,000 psi
Tensile Modulus	27,000,000 psi*
Nominal Diameter	10-12 μ
Density	3.05 gm/cm <sup>3</sup>
Surface Area	<0.2 m <sup>2</sup> /g
Refractive Index	1.617
Dielectric Constant	5.8 (at 9.375 × 10 <sup>9</sup> hertz)
Thermal Expansion Coefficient	
25-500°C	4.38 × 10 <sup>-6</sup> Δ L/L/°C
25-1000°C	4.99 × 10 <sup>-6</sup> Δ L/L/°C

## Fabric Properties

Nominal Shrinkage	1%
4 hours at 1400°C (2552°F)	
Nominal Weight Loss	1.2%
4 hours at 1400°C (2552°F)	
Modified MIT Flex Endurance	50 Cycles
3 hours at 1350°C (2462°F)	
Modified Stoll Flex & Abrasion	700 Cycles
3 hours at 1350°C (2462°F)	

\*Tensile modulus can be increased to 32,000,000 psi. See Nextel 440 Heat Cleaning/Heat Treating instructions.

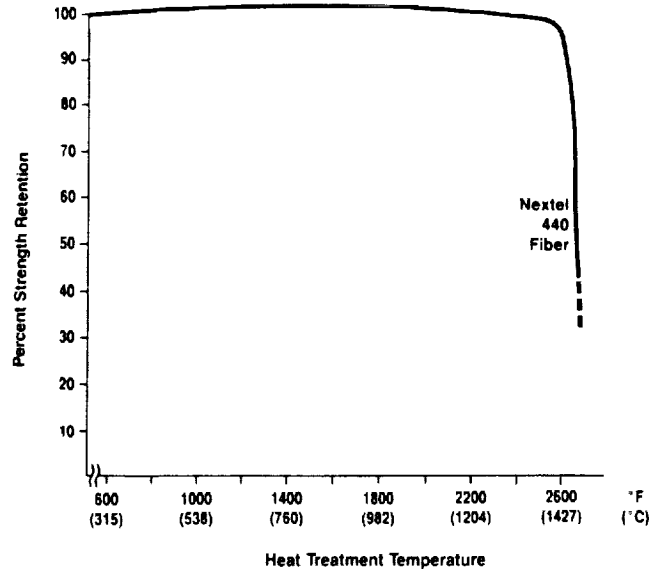

Strength Retention Versus Temperature for Nextel 440 Fibers After Heat Treatment for Four Hours in Air

PRELIMINARY NEXTEL 440 FIBER AND FABRIC DATA

	<u>NEXTEL 312</u>	<u>NEXTEL 440</u>
COMPOSITION	62% Al <sub>2</sub> O <sub>3</sub> 14% B <sub>2</sub> O <sub>3</sub> 24% SiO <sub>2</sub>	70% Al <sub>2</sub> O <sub>3</sub> 2% B <sub>2</sub> O <sub>3</sub> 28% SiO <sub>2</sub>
FILAMENT PROPERTIES		
Tensile Strength (psi)	200-250,000	200-300,000
Tensile Modulus (psi)	22,000,000	30-35,000,000
Nominal Diameter (μ)	10-12	10-12
Density (g/cm <sup>3</sup> )	2.7	3.1
Surface Area (m <sup>2</sup> /g)	< 0.2	< 0.2
Refractive Index	1.570	1.617
FABRIC PROPERTIES		
Nominal Shrinkage		
4 Hours at 1400°C (%)	3	1.0
Nominal Weight Loss		
4 Hours at 1400°C (%)	8	1.2
Modified MIT Flex Endurance		
3 Hours at 1350°C (Cycles)	0	50
Modified Stoll Flex and Abrasion		
3 Hours at 1350°C (Cycles)	0	700

**Fabric Breaking Strength vs Heat Treatment Temperature \***

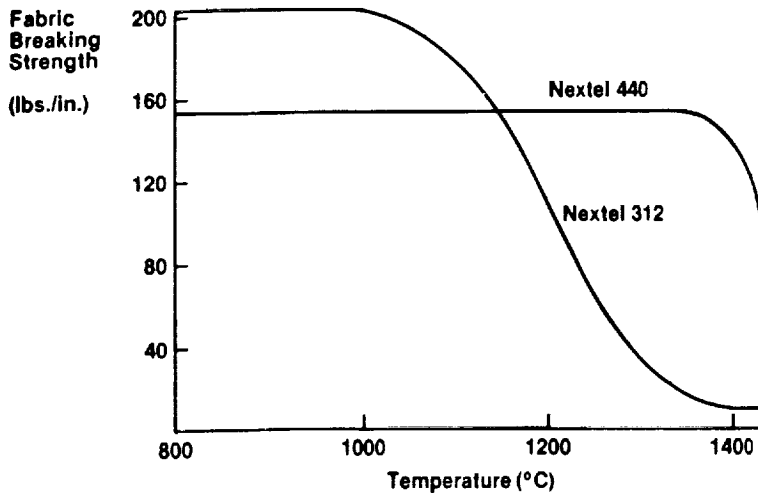

\*Samples treated three hours at temperature, tested at room temperature, 3-inch gauge length, warp direction 5HS weave, 25 oz/yd'



## Important Processing Information

Nextel 440 Ceramic Fibers are coated during manufacture with sizings or finishes which serve as aids in processing. These sizings may decompose to hazardous byproducts or process contaminants when first heated. Heat cleaning and heat treating are

available to meet your safety or process requirements. See our Nextel 440 Heat Cleaning/Heat Treating Procedure bulletin and our Product Safety bulletin for more information.

## Terms and Conditions of Sale

All statements, technical information and recommendations contained herein are based on tests we believe to be reliable, but the accuracy or completeness thereof is not guaranteed. The following is made in lieu of all warranties, expressed or implied.

Seller's and manufacturer's only obligation

shall be to replace such quantity of the product proved to be defective. Neither seller nor manufacturer shall be liable for any injury, loss or damage, direct or consequential, arising out of the use of or the inability to use the product. Before using, user shall determine the suitability of the

product for their intended use, and user assumes all risk and liability whatsoever in connection therewith.

Statements or recommendations contained herein shall have no force or effect unless in an agreement signed by officers of seller and manufacturer.

CERAMIC FIBER PRODUCTS CERTIFICATE OF CONFORMANCE

This is to certify that the following Ceramic Fiber Products

Units	Product Number	Description
<u>108.4</u> <u>lbs.</u>	<u>98-0400-0578-1</u>	<u>Nextel 440 1000 Denier 1/2 2.7Z on Twister Bobbins</u> <u>with 170C Sizing</u>

have been shipped to:

Firm Name City, State & Zip

Woven Structures Compton, CA 90220-5210

On their Purchase Order Number WS7675 and conforms with the criteria established for this product construction as set forth in your purchase order.

Shipment Dates: 10/26/87 Lot 1081

The above certification does not change our normal terms and conditions of sale: "The following is made in lieu of all warranties, expressed or implied: Seller's only obligation shall be to replace such quantity of the product proved to be defective. Seller shall not be liable for any injury, loss or damage, direct or consequential, arising out of use of or the inability to use the product. Before using, user shall determine the suitability of the product for his intended use and user assumes all risk and liability whatsoever in connection therewith. The foregoing may not be changed except by an agreement signed by an officer of seller."

For Minnesota Mining and Manufacturing Company

J. L. Ellingson  
J. L. Ellingson, QC Supervisor 10/26/87  
 Name, Title Date

Menomonie, WI 54751 ZR 09346  
 Shipped From Invoice Number

Product Construction Shipped: Same as above.



SEE WSI STATUS  
 TAG # 31219

F-021

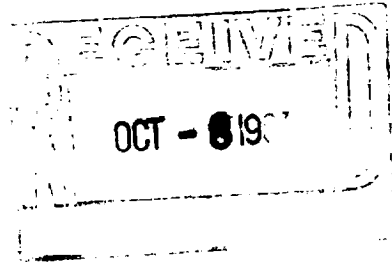

MATERIAL SAFETY  
DATA SHEET

DIVISION: CERAMIC MATERIALS DEPARTMENT  
TRADE NAME: NEXTEL 440 CERAMIC FIBER  
3M I.D. NUMBER: 98-0400-0248-1 98-0400-0249-9 98-0400-0260-6  
98-0400-0265-5 98-0400-0266-3 98-0400-0328-1  
98-0400-0360-4 98-0400-0361-2 98-0400-0362-0  
98-0400-0372-9 98-0400-0378-6 98-0400-0390-1

ISSUED: NOVEMBER 26, 1985  
SUPERSEDES: JUNE 1, 1984  
DOCUMENT: 10-4881-8

1. INGREDIENTS	C.A.S. NO.	PERCENT	EXPOSURE LIMITS
ALUMINA		68.0- 72.0	N/A 5
SILICA		26.0- 30.0	N/A 5
BORIA		0.0- 4.0	N/A 5
ORGANIC POLYMER SIZING 170*		1.0- 3.0	N/A 5
*UNLESS PRODUCT IS MARKED "HEAT-TREATED" OR "HEAT-CLEANED"		0.0	5

- SOURCE OF EXPOSURE LIMIT DATA
1. ACGIH THRESHOLD LIMIT VALUES
  2. FEDERAL OSHA PERMISSIBLE EXPOSURE LIMIT
  3. 3M EXPOSURE GUIDELINES
  4. CHEMICAL MANUFACTURER RECOMMENDED GUIDELINES
  5. NONE ESTABLISHED

ABBREVIATIONS  
N/D - NOT DETERMINED  
N/A - NOT APPLICABLE

2. PHYSICAL DATA

BOILING POINT: N/A  
 VAPOR PRESSURE: N/A  
 VAPOR DENSITY (AIR=1): N/A  
 EVAPORATION RATE ( = 1 ): N/A  
 SOLUBILITY IN WATER: 1-3% BY WEIGHT  
 SP. GRAVITY (WATER=1): 2.7  
 PERCENT VOLATILE: 1-3% BY WEIGHT  
 VISCOSITY: SOLID  
 pH: N/A  
 APPEARANCE AND ODOR: WHITE, SHINY THREAD OR YARN

MATERIAL SAFETY  
DATA SHEETMSDS: NEXTEL 440 CERAMIC FIBER  
NOVEMBER 26, 1985

Page 2

## =====

## 3. FIRE AND EXPLOSION HAZARD DATA

=====

FLASH POINT (N/A): N/A

FLAMMABLE LIMITS - LEL: N/A UEL: N/A

## EXTINGUISHING MEDIA:

N/A

## SPECIAL FIRE FIGHTING PROCEDURES:

N/A

## UNUSUAL FIRE AND EXPLOSION HAZARDS:

THE 170 SIZING WILL DECOMPOSE (SEE HAZARDOUS DECOMPOSITION PRODUCTS  
IN SECTION 4.)

## =====

## 4. REACTIVITY DATA

=====

STABILITY: STABLE

## INCOMPATIBILITY - MATERIALS TO AVOID:

NONE

HAZARDOUS POLYMERIZATION: MAY NOT OCCUR

## HAZARDOUS DECOMPOSITION PRODUCTS:

SMALL AMOUNTS OF CARBON MONOXIDE (CO), NITROGEN OXIDES (NOX),  
HYDROGEN CYANIDE (HCN), ACRYLONITRILE, AND, POSSIBLY, ETHYLENEIMINE  
MAY EVOLVE ON FIRST HEATING AS A RESULT OF SIZING DECOMPOSITION.  
ACRYLONITRILE AND ETHYLENEIMINE ARE REGULATED BY OSHA AS POTENTIAL  
HUMAN CARCINOGENS.

## =====

## 5. ENVIRONMENTAL INFORMATION

## =====

## SPILL RESPONSE:

OBSERVE PRECAUTIONS FROM OTHER SECTIONS.

USE DUST MASK.

COLLECT SPILLED MATERIAL.

VACUUM, USE WET SWEEPING COMPOUND, OR WATER TO AVOID DUSTING.

## RECOMMENDED DISPOSAL:

DISPOSE OF WASTE PRODUCT IN A SANITARY LANDFILL.

DISPOSAL SHOULD BE IN ACCORDANCE WITH APPLICABLE REGULATIONS.

U.S. EPA HAZARDOUS WASTE NO.: NONE

## ENVIRONMENTAL DATA:

MATERIAL SAFETY  
DATA SHEETMSDS: NEXTEL 440 CERAMIC FIBER  
NOVEMBER 26, 1985

Page 3

## =====

## 6. SUGGESTED FIRST AID

## =====

## EYE CONTACT:

IF EYE IRRITATION OCCURS, FLUSH EYES WITH WATER.

## SKIN CONTACT:

IF SKIN IRRITATION OCCURS, WASH AFFECTED AREA WITH SOAP AND WATER.  
REMOVE AND LAUNDRER CLOTHING BEFORE RE-USE.

## INHALATION:

## IF SWALLOWED:

## =====

## 7. PRECAUTIONARY INFORMATION

=====

LOCALIZED EXHAUST AND/OR USE OF NIOSH APPROVED DUST RESPIRATORS IS RECOMMENDED IN AREAS WHERE NEXTEL 440 CERAMIC FIBERS BECOME READILY AIRBORNE. ADEQUATE GENERAL VENTILATION AND GOOD HOUSEKEEPING PRACTICES REDUCE THE AMOUNT OF AIRBORNE FIBERS IN THE WORKPLACE. TEMPORARY LOCAL SKIN, EYE, OR UPPER RESPIRATORY SYSTEM IRRITATION MAY OCCUR WHEN PROCESSING OR USING NEXTEL CERAMIC FIBER MATERIALS. THIS IRRITATION IS SIMILAR TO THAT PRODUCED BY GLASS FIBERS, AND IS TYPIFIED BY ITCHING AND SLIGHT REDDENING AND SWELLING OF THE SKIN. PROCESSES WHICH YIELD EXCESSIVE FILAMENT BREAKAGE, SUCH AS CHOPPING, INCREASE THE POTENTIAL FOR SKIN IRRITATION. ADEQUATE LOCAL EXHAUST VENTILATION, GOOD HOUSEKEEPING PRACTICES, AND CAREFUL WORK HABITS HELP TO REDUCE EXPOSURE. SAFETY GLASSES AND PROTECTIVE CLOTHING SUCH AS LAB COATS, GLOVES, AND TIGHT FITTING CUFFS, PROVIDE ADDITIONAL PROTECTION TO SKIN AND EYES. NIOSH APPROVED DUST RESPIRATORS MAY BE USED TO FURTHER REDUCE INHALATION EXPOSURE TO AIRBORNE FIBERS. UNLESS THEY ARE MARKED "HEAT-CLEANED" OR "HEAT-TREATED", NEXTEL CERAMIC FIBER MATERIALS HAVE A SURFACE COATING (SIZING) WHICH IS APPLIED DURING MANUFACTURING AS A PROCESSING AID. THIS SIZING MAY PRODUCE SMALL QUANTITIES OF HAZARDOUS DECOMPOSITION PRODUCTS WHEN FIRST HEATED (SEE SECTION 4). HEAT CLEANING IS AVAILABLE TO MEET YOUR SAFETY OR PROCESS REQUIREMENTS. ANY OPERATIONS INVOLVING INITIAL HEATING OF NON-HEAT-CLEANED FIBERS SHOULD BE CONDUCTED WITH EFFECTIVE VENTILATION CAPABLE OF PREVENTING VAPOR AND GAS BUILD-UP. ALSO, THESE OPERATIONS SHOULD BE MONITORED FOR THE PRESENCE OF THE OFF-GASSES. GENERALLY, IF CARBON MONOXIDE LEVELS ARE KEPT BELOW THE THRESHOLD LIMIT VALUE, EXPOSURE TO THE OTHER COMPONENTS SHOULD BE INSIGNIFICANT. REFER TO THE HEAT CLEANING PROCEDURE BULLETIN AND PRODUCT SAFETY BULLETIN FOR ADDITIONAL INFORMATION.

MATERIAL SAFETY  
DATA SHEETMSDS: NEXTEL 440 CERAMIC FIBER  
NOVEMBER 26, 1985

Page 4

## =====

## 8. HEALTH HAZARD DATA

=====

NEXTEL CERAMIC FIBERS MAY PRODUCE MINOR MECHANICAL IRRITATION OF THE SKIN, EYES, NOSE, MOUTH AND THROAT FROM RELEASE OF FIBERS INTO THE AIR AND SETTLING ON PROCESS SURFACES DURING CERTAIN OPERATIONS. THIS IRRITATION IS SIMILAR TO THAT PRODUCED BY FIBERGLASS AND MAY INCLUDE ITCHING, REDDENING AND SLIGHT SWELLING OF CONTACT AREAS. SEE SECTION 7 FOR INFORMATION ON PRECAUTIONARY MEASURES WHICH CAN BE TAKEN TO MINIMIZE THE POSSIBILITY OF IRRITATION.

THE DECOMPOSITION PRODUCTS FROM INITIAL HEATING OF SIZED FIBERS MAY PRESENT A POTENTIAL HAZARD UNDER CERTAIN CONDITIONS. PLEASE REFER TO SECTIONS 4 AND 7 FOR ADDITIONAL INFORMATION.

THE INHALATION OF NEXTEL CERAMIC FIBERS IS NOT EXPECTED TO PRESENT A HEALTH HAZARD OTHER THAN MINOR NOSE, MOUTH AND THROAT IRRITATION. A TYPICAL FIBER MAY BE CHARACTERIZED AS HAVING A DIAMETER OF 7 TO 13 MICRONS AND A PRACTICALLY CONTINUOUS LENGTH. THESE PHYSICAL DIMENSIONS PRECLUDE SIGNIFICANT DEPOSITION OF FIBER IN THE LUNG. IN ADDITION, ANIMAL STUDIES IN WHICH GROUND AND CHOPPED NEXTEL 440 WERE INTRODUCED INTO THE LUNG THROUGH THE WINDPIPE DEMONSTRATED THAT THERE IS NO SIGNIFICANT PULMONARY REACTION TO THESE MATERIALS.

=====

The information on this Data Sheet represents our current data and best opinion as to the proper use in handling of this product under normal conditions. Any use of the product which is not in conformance with this Data Sheet or which involves using the product in combination with any other product or any other process is the responsibility of the user.

**APPENDIX C**

**Manufacturer's Literature for Nextel 440 Ultrafiber Insulation**





PRELIMINARY Product Bulletin

NEXTEL<sup>®</sup> 440 ULTRAFIBER

Nextel<sup>®</sup> 440 Ultrafiber is a nonwoven blanket of fine ceramic fibers with no shot and no binders. Because of its uniform consistency, fine fiber diameter and relatively long fiber length, it exhibits excellent thermal insulation, sound absorption and filtration properties. The outstanding temperature resistance of the Nextel 440 composition means that the blanket is useful at temperatures of up to 2800<sup>°</sup>F.

Physical Properties

Appearance.....Uniform Nonwoven Web  
 Color.....White  
 Melting Point.....3350<sup>°</sup>F  
 Web Density.....0.65 - 0.70 lb/ft<sup>3</sup>  
 Fiber Diameter.....3.3 microns (mean)  
 Fiber Length.....1-8 inches  
 Web Tensile Strength.....Approx. 80 gm/in.  
 Thickness.....3/4 inches (approx.)  
 Specific Heat.....0.3 Btu/lb/<sup>o</sup>F at 1650<sup>o</sup>F

Fiber Composition

Alumina (Al<sub>2</sub>O<sub>3</sub>).....70% by wt.  
 Silica (SiO<sub>2</sub>).....28% by wt.  
 Boria (B<sub>2</sub>O<sub>3</sub>)..... 2% by wt.

Linear Shrinkage (24 hours)

2400 <sup>°</sup> F.....0.48%	2900 <sup>°</sup> F.....2.28%
2600 <sup>°</sup> F.....1.28%	3000 <sup>°</sup> F.....3.91%
2800 <sup>°</sup> F.....1.65%	

Apparent Thermal Conductivity

<u>Mean Temp</u>		<u>63 kg/m<sup>3</sup> (3.94 lb/ft<sup>3</sup>)</u>		<u>136 kg/m<sup>3</sup> (8.50 lb/ft<sup>3</sup>)</u>	
<u>°C</u>	<u>°F</u>	<u>W</u>	<u>BTU IN</u>	<u>W</u>	<u>BTU IN</u>
		<u>MK</u>	<u>H Ft<sup>2</sup> F</u>	<u>MK</u>	<u>H Ft<sup>2</sup> F</u>
200	392	0.055	0.381	0.051	0.353
400	752	0.087	0.603	0.072	0.499
600	1112	0.130	0.901	0.100	0.693
800	1472	0.195	1.35	0.140	0.971
1000	1832	0.295	2.04	0.193	1.34
1100	2012	0.360	2.50	0.228	1.58

NOTE: All statements, technical information and recommendations contained herein are based on tests believed to be reliable but the accuracy or completeness thereof is not guaranteed.

**MATERIAL SAFETY  
DATA SHEET**

Form 15593-C PWO

DUNS NO.: 00-617-3082

Chemical Family <b>Metal Oxides</b>	Trade Name <b>Nextel 440 Ultrafiber Mat</b>
--	--

3M I. D. Number **I&C Sector New Products Department**

<b>1. INGREDIENTS</b>	<b>CAS. #</b>	<b>%</b>	<b>TLV® (unit)</b>
Alumina (Al <sub>2</sub> O <sub>3</sub> )	1344-28-1	69	10 mg/m <sup>3</sup>
Boria (B <sub>2</sub> O <sub>3</sub> )	1303-86-2	2	10 mg/m <sup>3</sup>
Silica (SiO <sub>2</sub> ) amorphous	7631-86-9	29	20 mppcf
Mean Fiber Diameter: 3.5 μ			

**2. PHYSICAL DATA** N/A - Not Applicable

Boiling Point	N/A	Solubility in Water	0
Vapor Pressure	N/A	Specific Gravity (H <sub>2</sub> O=1)	3.1 - 3.2
Vapor Density (Air = 1)	N/A	Percent Volatile	0
Evaporation Rate (=1)	N/A	pH	N/A

Appearance and Odor **White fiber mat, no odor**

**3. FIRE AND EXPLOSION HAZARD DATA**

Flash Point (Test Method) N/A	Flammable Limits: LEL =	UEL =
Extinguishing Media		
Special Fire Fighting Procedures		

Unusual Fire and Explosion Hazards

**4. ENVIRONMENTAL INFORMATION**

Spill Response  
N/A

Recommended Disposal

Dispose with trash in accordance with state and local regulations.

Environmental Data

TRADE NAME: Nextel 440 Ultrafiber Mat

**5. HEALTH HAZARD DATA**

**Eye Contact**

Mat fibers or dust may produce physical irritation if rubbed in eyes.  
No chemical injury expected.

**Skin Contact**

Brittle fibers may produce irritation upon contact with bare skin. Wear protective gloves and clothing.

**Inhalation**

Inhalation of fibers may cause respiratory irritation. Intratracheal insufflation studies with a 5  $\mu$  version of the fiber revealed no fibrogenic response in rats.

**Ingestion**

N/A

**Suggested First Aid**

Eyes: Flush eyes with plenty of water. Call a physician.

Skin: Remove contaminated clothing. Wash affected area with soap and water.

Inhalation: Remove person to fresh air.

**6. REACTIVITY DATA**

<b>STABILITY</b> <input type="checkbox"/> Unstable <input checked="" type="checkbox"/> Stable	Conditions to Avoid
<b>INCOMPATIBILITY</b>	Materials to Avoid
<b>HAZARDOUS POLYMERIZATION</b> <input type="checkbox"/> May Occur <input checked="" type="checkbox"/> May Not Occur	Conditions to Avoid

**Hazardous Decomposition Products**

N/A

**7. SPECIAL PROTECTION INFORMATION**

<b>Eye Protection</b>	<b>Skin Protection</b>
Safety glasses	Gloves, protective clothing
<b>Ventilation</b>	Good general or local ventilation suggested to prevent dusting.
<b>Respiratory and Special Protection</b>	If severe dusting occurs, wear a NIOSH respirator for fibers and dust.
<b>Other Protection</b>	

**8. PRECAUTIONARY INFORMATION**

Fibers are brittle; avoid rough handling.

Dust from mat is a respiratory nuisance.

Launder clothing after contact.

**9. DEPARTMENT OF TRANSPORTATION**

<b>DOT Proper Shipping Name</b>	<b>DOT Hazard Class</b>
Not regulated	---

<b>Issue Date</b>	<b>Supersedes</b>
4/84	None



APPENDIX D

Manufacturer's Literature and Material Safety Data Sheet for Saffil Products

PRECEDING PAGE BLANK NOT FILMED



## ALUMINA BULK FIBER TYPE ALBF-1

### General Information

Alumina Bulk Fibers are SAFFIL® Alumina HT fibers which have been processed into relatively short fiber lengths, suitable for vacuum forming into rigid boards and shapes and for insulation packing in furnace spaces at optimum density for lowest thermal energy losses.

SAFFIL® alumina fibers provide all the desirable properties of established ceramic fibers including light weight, low thermal conductivity, low thermal mass, complete immunity to thermal shock and ease of installation. But they also provide significant advantages over other ceramics in four ways —

1. High dimensional stability
2. High temperature resilience
3. Refractoriness
4. Resistance to chemical attack

These advantages result from its microcrystalline structure and the addition of 4% silica as a grain growth inhibitor.

Type ALBF-1 fibers, when vacuum formed from a water slurry, yield a uniform fiber board or shape of 10-15 pcf density. Silica, alumina and aluminum phosphate binders can be used to form rigid refractory, low shrinkage thermal insulation products useable to 3100°F.

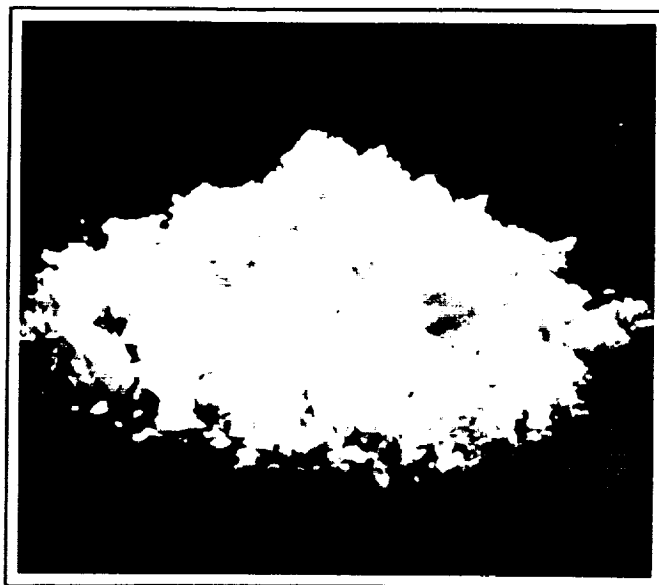

Alumina Bulk Fiber Type ALBF-1

Type ALBF-1 Alumina Fiber is an excellent product for using as fill and overlay for insulative packings around furnace sight tubes, ports, expansion joints, and masonry cracks. When blended into ZIRCAR Alumina Rigidizer/Hardener (See Bulletin No. ZPI-306), it forms a moldable insulation packing that fires out to a strong stable insulation.

### Properties of Type ALBF-1 Fibers

Fiber length, Mean mm (in)	3.2 (1/8)
Shipping Density gm/cm <sup>3</sup> (lb/ft <sup>3</sup> )	.1 (6)
Packed Density Range gm/cm <sup>3</sup> (lb/ft <sup>3</sup> )	.1 to .19 (6 to 12)
Shrinkage After	
1 hr soak at 1540°C (2800°F)	2%
1 hr soak at 1650°C (3000°F)	4%

### Properties of Individual SAFFIL® Alumina Fibers

Fiber Density gm/cm <sup>3</sup>	3.4
Melting Point, °C (°F)	2038 (3700)
Maximum Use Temperature °C (°F)	1650 (3000)
Specific Heat	0.25 BTU /lb°F
Tensile Strength	150 x 10 <sup>3</sup> psi
Young's Modulus	15 x 10 <sup>6</sup> psi
Mean Diameter	3 microns
Shot Content	negligible

Technical Data  
Bulletin No. ZPI-305  
December 1, 1986

**CERTIFICATE OF COMPLIANCE**

SHIP TO:

SOLD TO:

WOVEN STRUCTURE  
DIVISION OF HITCO  
618 WEST CAROB ST.  
COMPTON, CA 90220

CUSTOMER PURCHASE ORDER NO. WS7677	TAX AREA	TERMS	SHIP VIA UPS-BLUE	DATE TO BE SHIPPED 1/21/88
OUR ORDER NO. 871885	DATE ENTERED 9/21/87	SALESMAN 005	F.O.B.	DATE SHIPPED 1/21/88
			COL. <input type="checkbox"/> PPY <input type="checkbox"/>	PPY & ADD <input checked="" type="checkbox"/>

ITEM NO	DESCRIPTION	QTY ORDERED	QTY SHIPPED	UNIT	UNIT PRICE
	<p>CUSTOM ALUMINA BOARD 18" X 28" X 3/8"</p> <p>DENSITY AFTER BURNOUT AND EXPANSION TO 1/2"</p> <p>BD.3 : 6.4 LB/FT <sup>3</sup></p> <p>BD.4 : 6.6 LB/FT <sup>3</sup></p> <p>BD.5 : 6.4 LB/FT <sup>3</sup></p> <p>ORGANIC BINDER CONTENT:</p> <p>BD.3 : 11.4%</p> <p>BD.4 : 8.8%</p> <p>BD.5 : 14.2%</p> <p>THIS IS TO CERTIFY THAT THE MATERIAL SUPPLIED AGAINST THE SUBJECT ORDER IS IN ACCORDANCE WITH THE SPECIFICATIONS SET FORTH THEREON.</p> <p>Very truly yours, ZIRCAB Products, Inc. <i>[Signature]</i> Quality Control Supervisor 1-21-88 Date</p>	37	12		



**MATERIAL SAFETY DATA SHEET**

**MSD Identification/Trade Name and Synonyms**

(NOTE: Labels on products will show individual product trade names)

ALUMINA BULK FIBER

ALBF-1

-----SECTION I-----

**Manufacturer's Name** **Emergency Telephone Number**

ZIRCAR Products, Inc. (914)651-4481

**Address (Number, Street, City, State, Zip)**

110 North Main Street, Florida, NY 10921

**Chemical Name and Synonyms** **Formula**

Alumina Al<sub>2</sub>O<sub>3</sub>, SiO<sub>2</sub>

**Chemical Family** **Comments**

Alumina Ceramic Fiber SiO<sub>2</sub> < 5 wt.%

-----SECTION II HAZARDOUS INGREDIENTS-----

<b>A. AS MANUFACTURED</b>	<b>WT. %</b>	<b>TLV/PEL</b>
N/A	N/A	N/A

**B. AFTER NORMAL USE**

During installation it is common to handle this material. This process may generate respirable nuisance dust, the TLV/PEL is 5 mg/m<sup>3</sup>. (Reference: OSHA Standard 29 CFR Part 1910, Subpart Z.) Use of appropriate respiratory protection and proper ventilation is recommended.

-----SECTION III PHYSICAL DATA-----

<b>Boiling Point (F)</b>	N/A	<b>Specific Gravity Range (H<sub>2</sub>O=1)</b>	N/A
<b>Vapor Pressure (mm Hg)</b>	N/A	<b>Percent Volatile by Volume (%)</b>	N/A
<b>Vapor Density (Air=1)</b>	N/A	<b>Evaporation Rate ( =1)</b>	N/A
<b>Solubility in Water</b>	Insoluble		
<b>Appearance and Odor</b>	White, odorless fibers		

-----SECTION IV FIRE AND EXPLOSION HAZARD DATA-----

<b>Extinguishing Media</b>	<b>Flash Point (Method Used)</b>	<b>Flammable Limit</b>
N/A	N/A	N/A
<b>Unusual Fire &amp; Explosive Hazards</b>	<b>Special Fire Fighting Procedures</b>	<b>LEL UEL</b>
N/A	N/A	N/A N/A

-----SECTION V HEALTH HAZARD DATA-----

**Primary Route of Entry** Inhalation, ingestion and skin contact.

**Effects of Overexposure** Inhalation: May cause respiratory tract irritations. Pre-existing medical conditions may be aggravated by exposure. Ingestion: May cause gastrointestinal disturbances. Skin Contact: May cause drying of the skin and slight irritation (contact dermatitis).

**MATERIAL SAFETY DATA SHEET**

Page 2

**Emergency and First Aid Procedures**      Inhalation: Terminate exposure, seek medical attention if necessary.      Ingestion: DO NOT induce vomiting. Seek medical attention if necessary.      Skin Contact: Wash thoroughly with soap and water. Use of skin cream or lotion might be helpful. Seek medical attention if condition persists.

----- **SECTION VI      FIRE, EXPLOSIVE AND REACTIVITY DATA** -----

N/A

----- **SECTION VII      SPILL OR LEAK PROCEDURES** -----

**Recommended Procedure** Remove dust with vacuum fitted with HEPA filter. Use a dust suppressant.

**Waste Disposal Method** Routine housekeeping.

----- **SECTION VIII      SPECIAL PROTECTION INFORMATION** -----

A. **Respiratory Protection (Specify Type)** Avoid breathing dust. Use a dust respirator in compliance with OSHA Standard currently 29 CFR 1910.134.

B. **Ventilation Protection**

- **Local Exhaust** Follow OSHA Standard 29 CFR 1910.94.
- **Mechanical (General)** Follow OSHA Standard 29 CFR 1910.94.

C. **Mechanical Protection**

**Protective Gloves**  
Recommended

**Eye Protection**  
Goggles/face shield recommended

**Other Protective Equipment** Wear long sleeve, loose fitting clothing when handling in a manner that liberates loose fiber.

----- **SECTION IX      SPECIAL PRECAUTIONS** -----

N/A

As of the date of preparation of this document, the foregoing information is believed to be accurate and is provided in good faith to comply with applicable federal and state law(s). However, no warranty or representation with respect to such information is intended or given.

PREPARED BY: Philip Hamling  
Philip Hamling, Mgr. Research & Engineering

DATE: June 1986  
MSDS-14

MATERIAL SAFETY DATA SHEET

PM-016

001090

Form No.: 4870h(A)  
Date: 11/85

SECTION 1 NAME & HAZARD SUMMARY

Material name:  
SAFFIL® Alumina Fiber

Hazard summary (as defined by OSHA Hazard Communication Standard, 29 CFR 1910.1200):  
Physical hazards: None  
Health hazards: Inhalation (TLV), irritant (skin, eye)

Read the entire MSDS for a more thorough evaluation of the hazards.

SECTION 2 INGREDIENTS	%	TLV (ACGIH)
Alumina (CAS 1344-28-1)	95	Not listed
Silica, amorphous (CAS 60676-86-0)	5	10 mg/m <sup>3</sup>

Ingredients not precisely identified are proprietary or nonhazardous. All ingredients appear on the EPA TSCA Inventory. Values are not product specifications. gt = greater than, lt = less than, ca = approximately

SECTION 3 PHYSICAL DATA

Boiling point: Not applicable  
Vapor pressure (mmHg at 20°C): Negligible  
Vapor density (air = 1): Not applicable  
Solubility in water: Insoluble  
pH: Not applicable  
Specific gravity: No data  
% Volatile by volume: Negligible  
Appearance and odor: White odorless fibers

SECTION 4 FIRE AND EXPLOSION HAZARD DATA

Flash point (and method): Not applicable  
Autoignition temp.: Not applicable  
Flammable limits (STP): Not applicable

Extinguishing media:  
Not applicable. Use media suitable for surrounding fire.

Special fire fighting protective equipment:  
Not applicable.

Unusual fire and explosion hazards:  
None.

SECTION 5 REACTIVITY DATA

Stability:  
Stable under normal conditions.

## MATERIAL SAFETY DATA SHEET (continued)

SAFFIL® Alumina Fiber

---

**SECTION 5 REACTIVITY DATA (continued)**

---

Incompatibility (materials to avoid):

None known.

Hazardous decomposition products:

None.

Hazardous polymerization:

Will not occur.

---

**SECTION 6 HEALTH HAZARD ASSESSMENT**

---

General:

Limited toxicity data are available on this specific product; this health hazard assessment is based on the results of screening tests and on information from the scientific literature.

Ingestion:

The acute oral LD<sub>50</sub> in rat is above 5 g/kg. Relative to other materials, a single dose of this product is relatively harmless by ingestion, Hodge, H.C. and Sterner, J.H., American Industrial Hygiene Association Quarterly, 10:4, 93, Dec. 1949.

Eye contact:

Mechanical irritation can result after contact with this material.

Skin contact:

This material is a mild irritant in rat dermal irritation tests. It will probably be irritating to human skin following repeated/prolonged exposure.

Skin absorption:

This product is not absorbed through human skin.

Inhalation:

No toxic effects are known to be associated with inhalation of dust from this material. Irritation of mucous membranes of the upper respiratory tract may develop following exposure to this material.

Other effects of overexposure:

No other adverse clinical effects are known to be associated with exposures to this material. Studies suggest that the alumina fiber is too large to induce mesothelioma.

First aid procedures:

**Skin:** Wash material off the skin with copious amounts of soap and water. If redness, itching or a burning sensation develops, get medical attention.

**Eyes:** Immediately flush with copious amounts of water for at least 15 minutes. If redness, itching or a burning sensation develops, have eyes examined and treated by medical personnel.

---continued---

## MATERIAL SAFETY DATA SHEET (continued)

SAFFIL® Alumina Fiber

**SECTION 6 HEALTH HAZARD ASSESSMENT (continued)**

## First aid procedures (continued):

**Ingestion:** Give one or two glasses of water to drink. If gastrointestinal symptoms develop, consult medical personnel. (Never give anything by mouth to an unconscious person.)

**Inhalation:** Remove victim to fresh air. If cough or other respiratory symptoms develop, consult medical personnel.

**SECTION 7 SPILL OR LEAK PROCEDURES**

## Steps to be taken in case material is released or spilled:

Wear respiratory protection during cleanup. Sweep up and recover or mix material with moist absorbent and shovel into waste container.

## Disposal method:

Discarded product is not a hazardous waste under RCRA, 40 CFR 261.

**SECTION 8 SPECIAL PROTECTION INFORMATION**

## TLV® or suggested control value:

No TLV assigned. Minimize exposure in accordance with good hygiene practice. ICI Americas operates its facilities such that employee exposure to this material is kept below 10 mg/m<sup>3</sup>. The OSHA PEL for amorphous silica is 15 mg/m<sup>3</sup>.

## Ventilation:

Use local exhaust to keep exposures to a minimum.

## Respiratory protection (specify type):

If needed, use MSHA-NIOSH approved respirator for dusts, mists and fumes whose TLV is greater than 0.05 mg/m<sup>3</sup>.

## Protective clothing:

Impervious gloves and apron.

## Eye protection:

Safety glasses with side shields.

## Other protective equipment:

Eyewash station in work area.

**SECTION 9 SPECIAL PRECAUTIONS OR OTHER COMMENTS**

## Precautions to be taken in handling or storing:

Avoid breathing dusts.

The information herein is given in good faith  
but no warranty, expressed or implied, is made.





# Report Documentation Page

1. Report No.  NASA CR 177527		2. Government Accession No.		3. Recipient's Catalog No.	
4. Title and Subtitle  Tailorable Advanced Blanket Insulation Using Aluminoborosilicate and Alumina Batting				5. Report Date  July 1989	
				6. Performing Organization Code	
7. Author(s)  Dominic P. Calamito				8. Performing Organization Report No.	
				10. Work Unit No.  506-53-31	
9. Performing Organization Name and Address Woven Structures division of HITCO 618 W. Carob Street Compton, CA 90220				11. Contract or Grant No.  NAS2-12693	
				13. Type of Report and Period Covered  Contractor Report	
12. Sponsoring Agency Name and Address National Aeronautics and Space Administration Washington, D.C. 20546				14. Sponsoring Agency Code	
15. Supplementary Notes  Point of Contact: Paul M. Sawko, M/S 234-1 NASA Ames Research Center, Moffett Field, CA 94035 (415) 694-6079 FTS 464-6079					
16. Abstract  Two types of Tailorable Advanced Blanket Insulation (TABI) flat panels for Advanced Space Transportation Systems were produced. Both types consisted of integrally woven, three dimensional fluted core having parallel faces and connecting ribs of Nicalon silicon carbide yarns. The triangular cross section flutes of one type was filled with mandrels of processed Ultrafiber (aluminoborosilicate) stitchbonded Nextel 440 fibrous felt, and the second type filled with Saffil alumina fibrous felt insulation. Weaving problems were minimal. Insertion of the fragile insulation mandrels into the fabric flutes was improved by using a special insertion tool. An attempt was made to weave fluted core fabrics from Nextel 440 yarns but was unsuccessful because of the yarn's fragility. A small sample was eventually produced by an unorthodox weaving process and then filled with Saffil insulation. The procedures for setting up and weaving the fabrics and preparing and inserting insulation mandrels are discussed. Characterizations of the panels produced are also presented.					
17. Key Words (Suggested by Author(s)) Alumina Batting; Thermal Protection Blanket; High-Temp Insulation Blanket; TABI; Fluted Core Fabric; Silicon Carbide Fabric; Integrally Woven Fluted Core; Flexible Insulation Blanket; Aluminoborosilicate Batting;				18. Distribution Statement  [REDACTED] Subject Category 27	
19. Security Classif. (of this report)  UNCLASSIFIED		20. Security Classif. (of this page)  UNCLASSIFIED		21. No. of pages  98	22. Price  A09

