

6-15-11
E6179

NASA Technical Memorandum 104374

Enhancing Aeropropulsion Research With High-Speed Interactive Computing

John R. Szuch, Dale J. Arpasi,
and Anthony J. Strazisar
*Lewis Research Center
Cleveland, Ohio*

Prepared for the
10th International Symposium on Air-Breathing Engines
sponsored by the American Institute of Aeronautics and Astronautics
Nottingham, England, United Kingdom, September 1-6, 1991

NASA

ENHANCING AEROPROPULSION RESEARCH WITH HIGH-SPEED INTERACTIVE COMPUTING

John R. Szuch, Dale J. Arpasi, and Anthony J. Strazisar
National Aeronautics and Space Administration
Lewis Research Center
Cleveland, Ohio 44135

Abstract

The NASA Lewis Research Center has committed to a long-range goal of creating a numerical "test cell" for aeropropulsion research and development. Efforts are underway to develop a first-generation Numerical Propulsion System Simulation (NPSS). The NPSS will provide a unique capability to numerically simulate advanced propulsion systems from "nose to tail." Two essential ingredients to the NPSS are: (1) experimentally-validated CFD codes and (2) high-performance computing systems (hardware and software) that will permit those codes to be used efficiently. To this end, the NASA Lewis Research Center is using high-speed, interactive computing as a means for achieving Integrated CFD and Experiments (ICE). This paper describes the development of a prototype ICE system for multi-stage compressor flow physics research.

Introduction

To prove that a new engine design will deliver desired levels of operability, performance, and reliability, engine companies must still resort to an iterative, "cut and try" process of building and testing individual components, subsystems (e.g., cores), and complete engines. This methodology, while well established, commands a very high price in time and money to take a new engine concept through certification. While this price has been considered affordable for the past and current generations of engines, there is widespread concern that new mission and operational requirements (e.g., hypersonic flight) will result in engine designs that go far beyond the limits of past experience and data. This will make it impractical, if not impossible, to extrapolate from old designs and

could drive the cost of conducting "business as usual" to unacceptable levels.

The recent history of aeropropulsion has been marked by numerous efforts to develop and utilize computational techniques to speed up the propulsion design process and to produce better propulsion system designs. Steady advances in technical disciplines such as Computational Fluid Dynamics (CFD) have helped to increase the understanding of propulsion physics and have begun to impact the way the propulsion industry approaches the design of certain parts of a new propulsion system.^{1,2}

However, the propulsion industry is still a long way from being able to design and test an advanced technology engine on the computer. Computational design and analysis tools tend to be simplistic and used as part of the traditional (i.e., sequential, iterative, discipline-by-discipline, component-by-component) development process. Where effort has been made to resolve and capture the finer details of propulsion physics, the resultant codes have tended to require computing times that are too high for design purposes and have lacked the maturity/validity required to produce credible predictions of performance, stability, life, etc., even for isolated components.

The NASA Lewis Research Center has adopted a long-range vision of a numerical "test cell" for aeropropulsion research and development. Many of the Lewis organizations and research teams are now directing their research and technology activities toward the development of a first-generation Numerical Propulsion System Simulation (NPSS) that will provide unique capabilities to numerically simulate, analyze, and optimize advanced

propulsion systems and their constituents.³ As shown in Fig. 1, the NPSS concept is based on a combination of (1) experimentally-validated, multidisciplinary codes and (2) high-performance computing systems (hardware and software). The development of the validated codes depends on the availability of appropriate numerical algorithms, representative models of the physical processes, and detailed, experimental data upon which to base the CFD code development and validation. High-performance computing technology can also play a significant role in both code development and validation. This paper describes how high-speed interactive computing systems are being used to integrate CFD developments/analyses and propulsion flow physics experiments at NASA Lewis. This work is being performed in support of the Multistage Compressor Flow Physics Program.

Multistage Compressor Flow Physics Program

The Multistage Compressor Flow Physics Program is aimed at (1) increasing our fundamental understanding of the flow physics that limit the performance of multistage axial compressors in order to achieve significant expansion of multistage compressor operating envelopes and (2) conducting experimental and numerical experiments in order to develop more accurate codes for the numerical prediction of multistage compressor performance.

Multistage axial compressors are found in all high-performance military gas turbine aircraft engines as well as in engines used on all large commercial transport aircraft. The compressor draws air into the front of the engine and raises its temperature and pressure before passing the air into the engine combustor. The performance of the compressor can have a major effect on the overall engine performance and fuel-efficiency. The first goal of the Multistage Compressor Flow Physics Program addresses the desire to improve compressor performance.

Multistage axial compressors consist of alternating rows of rotating and stationary blades, each of which look like a small aircraft wing. A typical multistage compressor may have as many as 10 rotor-stator pairs (stages) which consist of several hundred individual blades. Numerical prediction of the complete, three-dimensional, unsteady flow field within a multistage compressor cannot be done in a reasonable amount of computing time on currently available supercomputers such as the Cray Y-MP. Researchers at NASA Lewis have developed a computationally-efficient numerical scheme known as the average-passage approach.⁴ The average-passage approach only requires the steady flow details to be solved numerically. Unsteady flow details are represented by mathematical closure models. Empirical data, required for development of average-passage closure models are being obtained through limited execution of unsteady CFD codes and acquisition of detailed flow field measurements within multistage axial compressors.

The aim of the Multistage Compressor Flow Physics Program is to increase our understanding of compressor flow physics through a combined experimental/numerical research effort. In order to obtain detailed flow field measurements of the mixing phenomena between blade rows in the multistage compressor environment, a large, low-speed research compressor is being constructed at NASA Lewis. The Low-Speed Multistage Axial Compressor, shown in Fig. 2, is 4 ft in diameter and will rotate at 1000 rpm. The compressor has an inlet guide vane row of stationary blades followed by four compressor stages. Each stage consists of a rotor blade row with 39 blades and a stator blade row with 52 blades. The compressor was carefully patterned after an existing low-speed compressor which has been used extensively to generate the same unsteady, complex flow patterns found in the high-speed compressors of actual aircraft gas turbine engines.⁵ The large size and low speed of

the compressor allow the use of flow visualization techniques and flow measurement techniques which are not possible in high speed environments. Data from the low speed compressor will be complemented by less-detailed data from high-speed compressor experiments in order to develop a more complete picture of mixing phenomena in multistage machines.

High Performance Computing for CFD

As Fig. 3 illustrates, the limits of today's computers (as defined by achievable performance and cost) force propulsion analysts (e.g., CFD) to compromise simulation fidelity and/or simulation extent in order to keep computing times within acceptable limits. Here, "acceptable" can take on a totally different meaning depending on the application.

For closed-loop testing of new control system designs, real-time simulations of engine system dynamics are required. A typical real-time engine simulation may require integration time steps of a millisecond or less.⁽⁶⁾ To date, this requirement has limited such simulations to one-dimensional representations of the engine flow processes.

For parametric studies of multistage compressor designs, two- and three-dimensional flow simulations are needed with flow field solutions obtainable in less than a few hours. These requirements are currently satisfied using the average-passage representation of each blade row.⁴ Recent studies by Mulac et al., running the average-passage model on a dedicated 8-processor CRAY Y-MP (i.e., peak performance of 3 billion Floating Point Operations per Second), required 1- $\frac{1}{2}$ hr to compute the steady-state flow field in a four stage (i.e., eight blade row) compressor.⁷

For detailed analyses of three-dimensional unsteady flow phenomena, higher degrees of spatial and temporal accuracy are required. A number of efforts are currently underway to develop

three-dimensional time-accurate, viscous flow codes.^{8,9} These codes could serve as the basis for development of the closure models that are required for the average-passage model. Unfortunately, such codes will require very large amounts of computing time (i.e., hundreds to thousands of hours for a single flow field solution), even on today's most powerful supercomputers.

When the computational requirements for these kinds of single discipline/single component analyses are extrapolated to "nose-to-tail" system simulations, involving multiple disciplines (e.g., fluid dynamics, structural dynamics, combustion, heat transfer), it becomes evident that the NPSS concept represents a "grand" challenge - not only in terms of acquiring high performance computers that have the raw power to execute trillions of floating point operations per second (i.e., TeraFLOPS) but also in terms of propulsion code developers and analysts being able to extract that kind of performance to solve real, practical propulsion applications.

Figure 4 shows that "massively" parallel processors, based on hundreds to tens of thousands of microprocessors, appear to hold the most promise for achieving the 2 to 3 orders of magnitude increases in performance that are needed, relative to today's supercomputers. Parallel processing is based on the assumption that a problem can be subdivided into a number of smaller problems that can be run concurrently (i.e., in parallel) on multiple processors with intermediate results exchanged as needed while proceeding to the final solution. If the problem can be subdivided repeatedly into smaller and smaller pieces without having the individual processor workloads become so small that interprocessor communications become dominant, then it is possible to think in terms of massively parallel processing. Another important factor in the move toward massively parallel processing, is the 1 to 2 orders of magnitude improvement in cost/performance, relative to

today's supercomputers, that are offered my microprocessor technology.

At NASA Lewis, parallel processing efforts are underway, utilizing small-scale parallel processing test-beds. These include a 16-processor hypercube, based on the Intel i860 microprocessor¹⁰ and a 32-processor Hypercluster system, based on the Motorola MC8800 microprocessor.¹¹ These testbeds are being used to develop parallel algorithms and mapping strategies for a multistage compressor CFD application. The knowledge gained in this effort will be invaluable in subsequent Lewis efforts, under the NASA High Performance Computing and Communications (HPCC) program, that will be aimed at full-engine simulations on TeraFLOPS-level computer systems.

High Performance Computing for Experiments

While CFD applications have gotten most of the attention in high performance computing, the criticality of having detailed physical experiments to support the development and validation of propulsion CFD models would suggest that we also consider how high performance computing can enhance those experiments. The following paragraphs describe the data processing requirements associated with the Multistage Compressor Flow Physics program.

The key experimental measurement techniques that will be used testing the Low Speed Axial Compressor are hot-wire anemometry and laser anemometry. Both of these techniques are capable of measuring the three-dimensional velocity field which exists within the compressor. The laser anemometer is capable of making measurements within rotating blade rows since only the laser light beams penetrate into the flow field. The hot-wire anemometer is capable of making measurements between the blade rows and within the stationary blade rows, since this technique requires that a probe be inserted into the flow through the compressor casing. The Low-Speed Axial Compressor also has the capability of carrying a hot-wire probe

on-board the rotor behind the third-stage rotor blade row.

Both anemometer systems acquire data at a measurement point which is fixed relative to the stationary compressor casing. As the compressor rotor blades rotate past the measurement point, the measurement point sweeps out a measurement line as shown in Fig. 5 for a laser anemometer application. This measurement line is subdivided into measurement intervals using an electronic shaft angle encoder. The encoder outputs a fixed number of pulses for each rotor revolution and is synchronized to the rotor speed by a magnetic pickup mounted on the rotor. The time interval between adjacent encoder pulses defines a measurement interval. Each velocity measurement from an anemometer system is assigned to the measurement interval in which it occurred. This measurement scheme allows the periodically unsteady flow field which is moving with the rotor blades to be sampled from the stationary frame of reference in which the anemometers reside.

The data set which is acquired with the anemometer systems consists of two or three components of velocity in each measurement interval. A unique set of measurement intervals is assigned to each blade passage around a rotor blade row so that passage-to-passage differences in the flow can be studied. In order to achieve statistical confidence in the measurements, data is collected until many measurements have been acquired in each interval. A single run consists of data collected at a single axial-radial point in the flow field. A complete survey of the flow field for a given compressor operating condition might consist of runs acquired at 100 or more measurement points distributed in the axial and radial directions.

Each run in a multistage experiment might typically require processing of the following information:

128 rotor blade passages

128 measurement intervals per
blade passage
128 measurements in each
interval
3 velocity components for
each measurement

If one velocity component in one interval can be represented by a 16-bit word then the size of the total data set for a given run is $128 \times 128 \times 128 \times 3 \times 2$ bytes = 12.5 MB. Processing of the three velocity components can be done in parallel. Parallel processing can also be used to accelerate the data processing associated with: (1) averaging of the 128 measurements in each interval to determine the mean velocity for each interval, and (2) ensemble-averaging of the velocity distributions for each of the 128 blade passages to determine the velocity distribution in an "average" blade passage. These averaging operations greatly simplify the management and display of the experimental data and are, in fact, very similar to the averaging operations which make the average-passage CFD code computationally efficient compared to unsteady CFD codes which must track blade-to-blade non-uniformities caused by blade row interactions.

From the preceding discussion, one can see that the data acquired in rotating compressor environments leads to formidable data set sizes. In addition, both anemometer systems are capable of generating sustained data rates of 2000 measurements per second. This data rate and the size of the data sets have precluded the analysis of these data while the experiment is in progress. At best, preliminary data reduction must be performed overnight. This provides the experimentalist with an assessment of his measurements the next day. At this point, the test is no longer in progress and, if anomalies appear in the data, the experiment must be rerun and an attempt must be made to exactly repeat the experimental conditions which existed the previous day. This operating procedure makes it difficult to "capture" flow physics phenomena. Therefore, it is highly desirable to pro-

vide the experimentalist with the means to acquire, process, display, and analyze compressor flow data in near real-time. In this way, the experimentalist can react in a timely manner to observed characteristics of the flow field data.

High performance computing technology can be applied in a number of ways to meet the needs of the Low Speed Axial Compressor Experiment. Parallel processors can be used to exploit the parallelism that exists in the multidimensional data. Interactive graphics hardware and software can provide near real-time displays of measurement statistics and three-dimensional flow fields. Expert systems and knowledge-based systems can provide tools to access, manipulate, and assimilate the large, multidimensional datasets and allow the experimentalist to extract information from the data that can improve multistage compressor CFD models and codes.

Integration of CFD and Experiments

The Integrated CFD and Experiments (ICE) project has been initiated as part of the Multistage Compressor Flow Physics program. The objective of the ICE project is to develop high-speed, interactive computing technologies that can enhance, accelerate, and integrate CFD analyses and flow physics experiments. By focusing on the multistage compressor flow physics application, the ICE project aims to develop and demonstrate a prototype ICE system that features: (1) parallel processing to speed up the numerical simulation of three-dimensional flows in multistage compressors, (2) parallel processing and interactive graphics for real-time analysis of detailed hot-wire and laser anemometry measurements acquired in multistage compressor experiments, and (3) the use of knowledge-based systems, database management tools, and interactive graphics for integrated analysis of CFD and experimental results. ICE will provide the experimentalist with immediate access to graphical displays of measurement statistics, trends, velocity profiles, etc. By eliminating the long

delays usually associated with post-processing of experimental data, the researcher will be better able to understand the results of the experiment, to compare those results with CFD predictions, and to quickly act on the conclusions.

The bottom line in the ICE/Multistage project will be increased productivity. Through the use of high-speed, interactive computing, NASA Lewis researchers will seek to achieve a fuller understanding of multistage compressor flow physics with less time, effort, and cost expended. One of the keys to success in the ICE/Multistage project will be our ability to take advantage of the synergism that exists between the numerical and experimental approaches. In ICE/Multistage, the integration of CFD and experiments is being accomplished through a shared "knowledge base" and a common set of graphical analysis tools. When combined with the aforementioned real-time data processing and parallel-processor-based CFD simulation, these facilities provide a framework and an interactive environment for carrying out CFD analyses and physical experiments in a cooperative fashion to best achieve a research objective.

The ICE Architecture

The key elements of the ICE system, as it is presently conceived, are shown in Fig. 6. The three major subsystems of ICE are: Experiment Support, CFD Support, and Analysis Support. Each subsystem consists of a graphical interface that resides on a workstation and one or more sub-elements that perform the support functions for that subsystem.

Experiment Support Subsystem

The Experiment Support subsystem allows the user to control the acquisition, processing, and run-time monitoring of experimental data. Experimental measurements (e.g., from a laser anemometer) are processed (e.g., averaged, correlated, etc.) and made available to the

user in a variety of tabular and graphical formats during the course of a run. Experiment Support information can be passed through the Analysis Support subsystem to a central ICE database/knowledge base whereby experiment run-time histories, observed anomalies, test conditions, test article and facility configurations, etc., can be correlated. Although not implemented in the prototype ICE system, it is planned to eventually have the Experiment Support subsystem "close the loop" around the experiment and test article by adjusting test points based on current measurements and status, information obtained from the data base/knowledge base, and user specifications. This "intelligent" approach to experiment control is intended to minimize the number of test points required to define the relevant physics.

CFD Support Subsystem

The CFD Support subsystem allows the user to access and run CFD codes on selected computing platforms (e.g., supercomputers, parallel processors) that are available on the distributed computing network. One of the major thrusts of the ICE project is to develop/provide sufficient computational speed and turnaround capability to allow CFD results to be obtained not only prior to an experiment but also during the course of an experimental run (or sequence of runs). Through the CFD Interface, the user will be able to initialize the code, run the code, monitor results, and pass results through the Analysis Support subsystem to the ICE database/knowledge base. The CFD Support subsystem is intended to be "intelligent" from the standpoint that CFD parameters, boundary conditions, etc. can be derived in the subsystem from higher level, user-specified CFD information or from experiment information (e.g., test article geometry, facility parameters) contained in the knowledge base. The CFD Support subsystem also allows for correlation of CFD run-time histories, observed anomalies, CFD run conditions, computer performance measurements, turnaround time, etc.

Analysis Support Subsystem

The Analysis Support subsystem allows the user to build and manage the ICE database/knowledge base. The ICE database/knowledge base effectively integrates CFD and experiment information obtained from the CFD Support subsystem and the Experiment Support subsystem, respectively. For a particular application, the ICE database/knowledge base will contain test facility parameters, test article design information, test article parameters, test results, experiment documentation, and corresponding information on the CFD analysis. The database/knowledge base resides in a dedicated facility data farm. The Analysis Support subsystem provides the necessary facilities for processing that information, including high-level analysis functions for displaying results in three-dimensional graphical formats. The database/knowledge base management functions include both standard relational database capabilities and artificial intelligence-based capabilities. This allows for the use of object-oriented approaches to managing information and for the development of rule-based expert systems to aid in the analysis of CFD and experiment-derived information. The display capabilities include comprehensive, three-dimensional displays of test article geometry and derived flow fields and are intended to support both CFD and experiments (separately or concurrently for comparison purposes).

"Notebook" capabilities are included in all of the support subsystem interfaces. The notebook is used to document operations, analyses and events. Notebook entries may include user comments, screen "dumps," and historical events (such as system messages and operational changes). The notes can form the first level of documentation for the CFD analysis and experiment and, since they are tied to the results through the database/knowledge base, they can enhance the usefulness of those results for subsequent activities (e.g., reporting,

technology transfer, redesign of hardware, CFD and physical experiments).

ICE Prototype System

A prototype ICE system is being developed to support experiments and associated CFD analyses in the Low-Speed Compressor Facility (LSCF). The prototype ICE system design and development process, although targetted specifically to the LSCF facility, is being carried out with an eye toward establishing an ICE toolbox of software and hardware modules that can serve as a basis for other ICE applications. In the context of NPSS, it is envisioned that a large number of aeropropulsion test facilities at the NASA Lewis (e.g., combustion, acoustic, engine systems) will eventually incorporate ICE technology and that these individual systems will then be integrated into a global propulsion design/test/analysis capability. The modular, building block approach to developing ICE will produce both near-term benefits (i.e., for the multistage compressor flow physics program) and longer-term benefits (widespread utilization of ICE technology). To this end, portability, functional expansion, and modernization are all important considerations in the ICE system design.

The ICE development is utilizing the state-of-the-art in computational technology. To the extent possible, each subsystem is being implemented with commercially available hardware and software. The project is expected to further the state-of-the-art in many areas, including techniques for formulating and managing scientific knowledge bases, distributed computing, and parallel processing. Important advancements in graphical flow-field analysis, and in the application of expert system technology to experimental and CFD procedures are also anticipated.

The detailed designs of the three ICE support subsystems are based on the specific requirements associated with the

Multistage Compressor Flow Physics program and the Large Low-Speed Axial Compressor tests.

Experiment Support Subsystem

The prototype implementation of the Experiment Support Subsystem must be able to perform statistical calculations on measurements from a laser fringe anemometer (LFA) and display the results in real-time. As shown in Fig. 7, the Experiment Support subsystem is utilizing parallel processing to achieve the desired performance capabilities. Six microprocessors are configured into three channels to compute the real-time statistics. The microprocessors are industry standard VMEbus products and are housed in a separate cabinet. For each channel, the two microprocessors share data acquisition responsibility and communicate with each other via a separate (VSB) bus. One of the microprocessors computes unaveraged statistics while the other computes ensemble-averaged statistics. The cabinet is connected to a Silicon Graphics Personal IRIS workstation which serves as the subsystem user interface. All of the raw measurement data are stored on an optical disk. The six microprocessors cooperate to compute the running mean velocity, and standard deviation and pass results to the Personal IRIS for periodic updates of user-selected displays. The Personal IRIS communicates information to the ICE knowledge base through a local area network.

Figure 8 illustrates the layout of the user interface screen. The top window of the screen is used for: graphical displays of measurement statistics, test article geometry, measurement probe locations, and three-dimensional flow fields (produced by the Analysis Support subsystem from experiment or CFD-derived data). Single and dual display modes are available. The remainder of the screen is reserved for overall subsystem management. The vertical buttons on the left of the screen are used to control the displays in the top window and to obtain a hard-copy of the screen. A button is

"depressed" by clicking on the button with a mouse. The vertical buttons on the right are used to control the data acquisition process. The bottom right window displays general information about the experiment. The buttons located below the window are used to select information to be displayed. The user can page through the information and can copy the current information display to the note pad.

The note pad is contained in the bottom left window and is controlled using the buttons located below the window. Three different note pads are available: one related to the current test article, one related to the current experiment, and one related to the current survey location. The latter note pad records all system-generated messages. The user may add notes and screen "photos" to any of the notepads.

CFD Support Subsystem

The prototype implementation of the CFD Support Subsystem must allow the user to access, set up, run, and display results from the CFD code of choice (i.e., average passage calculations for a five blade-row machine). The goal is to provide turnaround times on the order of 1 hr. As discussed earlier, this implies dedicated computing power that is equivalent to a CRAY Y/MP. For the ICE prototype, two options are being considered for the compute "engine": (1) a 16-processor Intel iPSC/860 hypercube system, remotely located in Lewis' Research Analysis Center and accessed via the Lewis-wide distributed computing network, and (2) the 32-processor Hypercluster parallel processing system, close-coupled to the rest of the ICE system via an Ethernet local-area network.

Two factors will determine how successful we are in achieving the desired parallel processor performance: (1) our ability to identify the physical and computational parallelism that exists in the average-passage, multistage formulation and (2) our ability to effectively map

that parallelism onto the parallel architectures of choice. Mulac, et al.,^{4,6} utilize the multitasking features on the Cray X-MP and Cray Y-MP to exploit the physical parallelism that exists in the average-passage model. Basically, they assign each Cray processor to a particular blade row. The blade row calculations are run in parallel. When those calculations are completed, results are compared and the process is repeated until the solution converges. For the ICE application, this approach is being extended to exploit two levels of parallelism in the model and in the Hypercluster architecture. The multitude of grid points that make up a flow field solution for a given blade row are being distributed among the Hypercluster nodes (1 to 32). Each blade row (1 to 9) solution will be computed, in parallel, by one of the four clustered (i.e., shared memory) processors at each node. The Hypercluster uses the Motorola MC88000 microprocessor. The peak computing power of the 32-processor Hypercluster is approximately 225 Mflops. For the 4- $\frac{1}{2}$ stage calculations, the Hypercluster solution time is expected to be on the order of 8 hr.

The CFD Support Subsystem also uses a Personal IRIS workstation as the user interface. The interface is intended to be "intelligent" in the sense that the details of setting up and running of the CFD code will be handled by the interface using information about the test article/conditions from the LSCF knowledge base. The interface will translate test article geometry files, test facility configuration and condition data, and aero measurement data into parameter files (e.g., initial and boundary conditions) for the CFD code. The design of the "intelligent" interface is based on earlier work by Williams.¹²

Once the code is setup, the interface can be switched either to interactive or batch operation to begin the solution. A user interface screen, similar to that shown in Fig. 8 for Exper-

iment Support, is provided for CFD Support during interactive operation. However, instead of monitoring the physical experiment, the display area is primarily used to show intermediate CFD results. The subsystem mode controls, information window, and note pad window provide comparable functions. As available, CFD results are returned to the user interface via the network system and are subsequently passed on to the knowledge base.

Analysis Support Subsystem

The major function of the Analysis Support Subsystem is to provide access to the knowledge base. In general, this access will be through various display and analysis tools that reside on the Analysis Support Subsystem's Personal IRIS user interface. Two of the most essential tools are currently under development: (1) an Interactive Data Display System (IDDS) that provides powerful, three-dimensional flow field plotting capabilities that are needed for the turbomachinery application and (2) a scientific relational database/knowledge base manager. The ICE database/knowledge base facilities are being developed using a combination of ORACLE and Nexpert Object. The incorporation of other analysis tools to enhance the usefulness of integrated data is anticipated and will be necessary to achieve the full potential of ICE.

A simplified ICE knowledge base is illustrated in Fig. 9. The highest level record in the knowledge base is an ENTRY record that defines a particular entry of a test article into the LSCF facility. The ENTRY record contains a textual description of the test article, its geometry, any previous data files, a description of the facility as it existed for this entry, and the pertinent documentation (notes) that were made during the entry. An ENTRY record also contains links to an open-ended number of associated CFD SIMULATION (Sim.1, ...) and physical EXPERIMENT (Exp.1, ...) records.

A SIMULATION record contains the CFD source code, the translator required to set up the CFD simulation from the knowledge base, the grid generator for the code, and all documentation (notes) pertinent to the CFD simulation. It also contains links to records of associated CFD simulation RUNs (Run 1, ...) and records that define the computing (e.g., parallel processing) MACHINES (Mach.1, ...) that are available in the distributed computing environment for running the CFD simulation. In general, a run-time MACHINE record will contain the CFD simulation object code, a configuration file to map the code onto the machine's architecture (if it is a parallel processor), and a run-time library to use during the formation of the load modules. If a machine can only be used in one way, then the load module can be pre-established.

An EXPERIMENT record contains the facility and test article parameters that make the experiment unique, and documentation pertinent to the experiment. The record also contains links to each measurement survey RUN (Run 1, ...) as part of the EXPERIMENT. Those records contain the parameters specific to the survey (laser position, etc.), the file of facility measurements taken during the survey, the file of raw laser measurements, and the computed file of statistically-processed velocity information. Survey documentation is also contained in the records.

The aforementioned knowledge base description is preliminary and has not been tested in the LSCF facility environment. It is anticipated that additions to and restructuring of the knowledge base will occur as the ICE prototype development proceeds.

Development Plans and Status

At this writing, work is proceeding on the buildup and testing of both the Experiment Support and Analysis Support subsystems. By the end of calendar year 1991, those subsystems are expected to be

operational and validated using precollected single-stage compressor test data and associated CFD results. Upgrading and expansion of the Hypercluster is underway. By August 1991, the 8-node/32 processor system should be operational. That system will be used to support the development of the multistage compressor CFD simulation and the CFD Support subsystem user interface. A parallel version of the average-passage model (for a single stage) is currently being developed for the iPSC/860 hypercube. That effort will form the basis for further parallelization of the model. Plans call for having a scalable, hierarchical implementation of the multistage model running on the Hypercluster by mid 1992. By mid-1993, the Experiment Support and Analysis Support subsystems are expected to be fully operational and integrated with a common user interface. That system will be directly tied in to the laser anemometry system and validated, on-line, in conjunction with planned tests of the large, low-speed multistage axial compressor. Functional integration of all ICE subsystems and on-line validation tests should be completed by mid-1994. During the course of the ICE system development, enhancements to the ICE subsystem designs and advances in the underlying hardware and software technologies are expected to occur. By 1995, we expect to have factored, into the ICE design, results from the multistage axial compressor tests and to be applying the ICE system to planned tests of advanced centrifugal compressor designs.

Concluding Remarks

The Multistage Compressor Flow Physics program is providing an opportunity for both propulsion CFD and flow physics experiments to exploit the tremendous advances that are taking place in high performance computing technology. Particularly important are those advances that will allow dedicated, high-speed, interactive computing to be used as an integral part of the propulsion research. The resultant gains in research quality

and productivity will have a major impact on making the "numerical test cell" a reality for propulsion. New capabilities are being put in place that will allow critical propulsion design issues to be resolved on the computer before hardware commitments are made. To the engine developer, this should mean fewer engine builds and tests being required with engine tests concentrated on final design validation and certification.

REFERENCES

1. "Current Capabilities and Future Directions in Computational Fluid Dynamics," National Research Council, NASA CR-179946, 1986.
2. Egolf, T.A. and Massar, J.P., "Helicopter Free Wake Implementation on Advanced Computer Architectures," Second International Conference on Basic Rotorcraft Research, University of Maryland, College Park, Maryland, Feb. 16-18, 1988.
3. Lytle, J.K., Remaklus, D.A., Szuch, J.R., Nichols, L.D., "Numerical Propulsion System Simulation," Third Air Force/NASA Symposium on Recent Advances in Multidisciplinary Analysis and Optimization, San Francisco, California, Sept. 24-26, 1990.
4. Mulac, R.A., Celestina, M.L., Adamczyk, J.J., Misegades, K.P., and Dawson, J.M., "The Utilization of Parallel Processing in Solving the Inviscid Form of the Average-Passage Equation for Multistage Turbomachinery," AIAA 87-1108, AIAA 8th Computational Fluid Dynamics Conference, Honolulu, Hawaii, June 9-11, 1987.
5. Wisler, D.C., "Loss Reduction in Axial-Flow Compressors Through Low-Speed Model Testing," ASME Journal of Engineering for Gas Turbines and Power, Vol. 107, pp. 354-363, 1985.
6. Milner, E.J. and Arpasi, D.J., "Simulating a Small Turbohaft Engine in a Real-Time Multiprocessor Simulator (RTMPS) Environment," NASA TM-87216, 1986.
7. Mulac, R.A. and Adamczyk, J.J., "The Numerical Simulation of a High-Speed Axial Flow Compressor," Accepted for presentation at 1991 IGTI Gas Turbine Conference, Orlando, Florida, June 3-6, 1991.
8. Whitfield, D.L. and Janus, M., "A Simple Time-Accurate Turbomachinery Algorithm with Numerical Solutions of an Uneven Blade Count Configuration," AIAA Paper 89-0206, Jan. 1989.
9. Rai, M.M., "Unsteady Three-Dimensional Simulations of Turbine Rotor-Stator Interaction," AIAA Paper 87-2058, 1987.
10. Kohn, L. and Margulis, N., "The i860 64-Bit Supercomputing Microprocessor," Supercomputing '89, pp. 450-456, Nov. 1989.
11. Blech, R.A., "The Hypercluster: A Parallel Processing Test-Bed Architecture for Computational Mechanics Applications," NASA TM-89823, 1987.
12. Williams, A.D., "The Development of an Intelligent Interface to a Computational Fluid Dynamics Flow-Solver Code," NASA TM-100908, Symposium on Advances and Trends in Computational Structural Mechanics and Fluid Dynamics, Oct. 17-19, 1988.

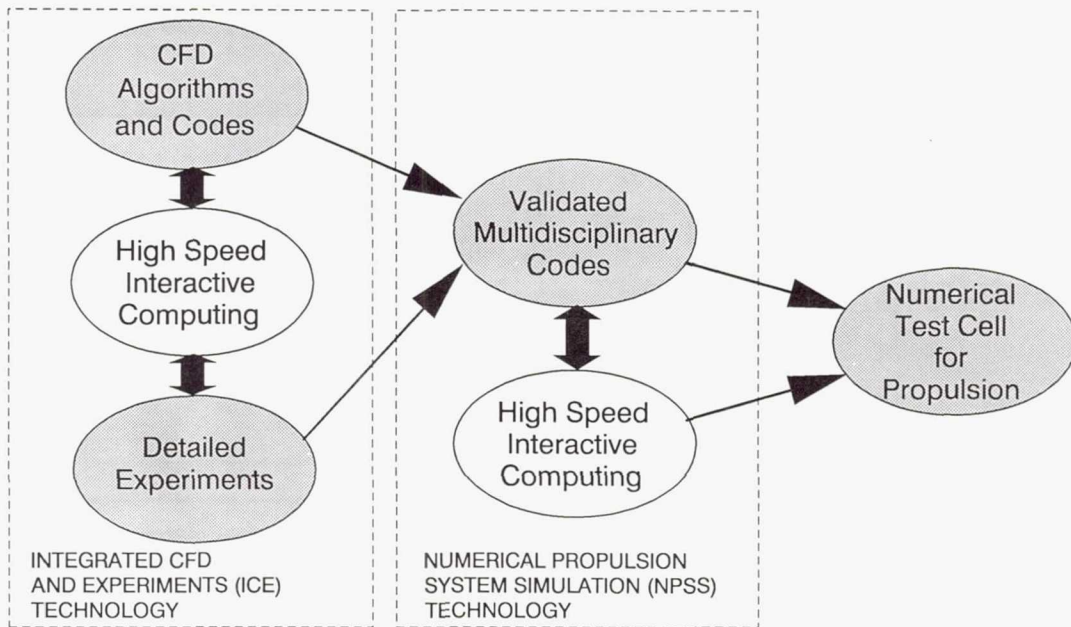

Figure 1.—The long range vision in aer propulsion analysis.

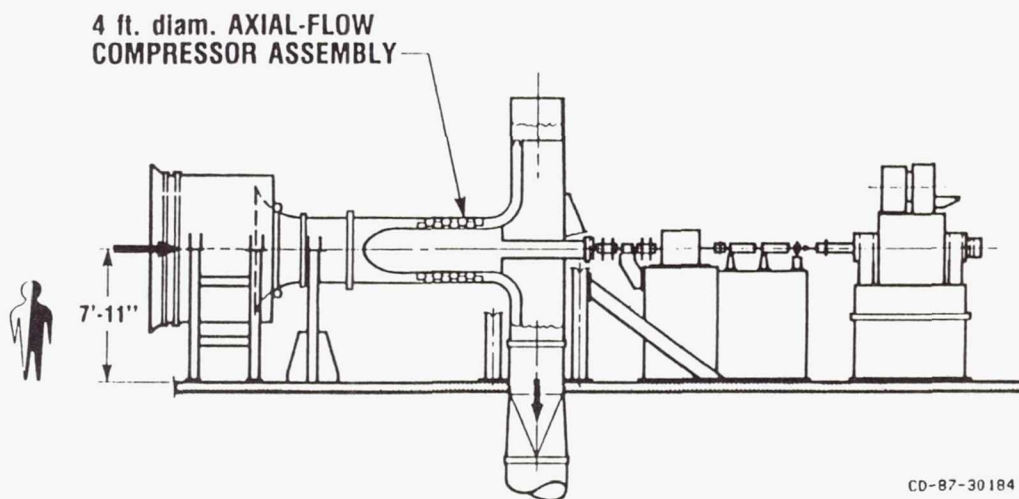

Figure 2.—Low speed multistage axial compressor.

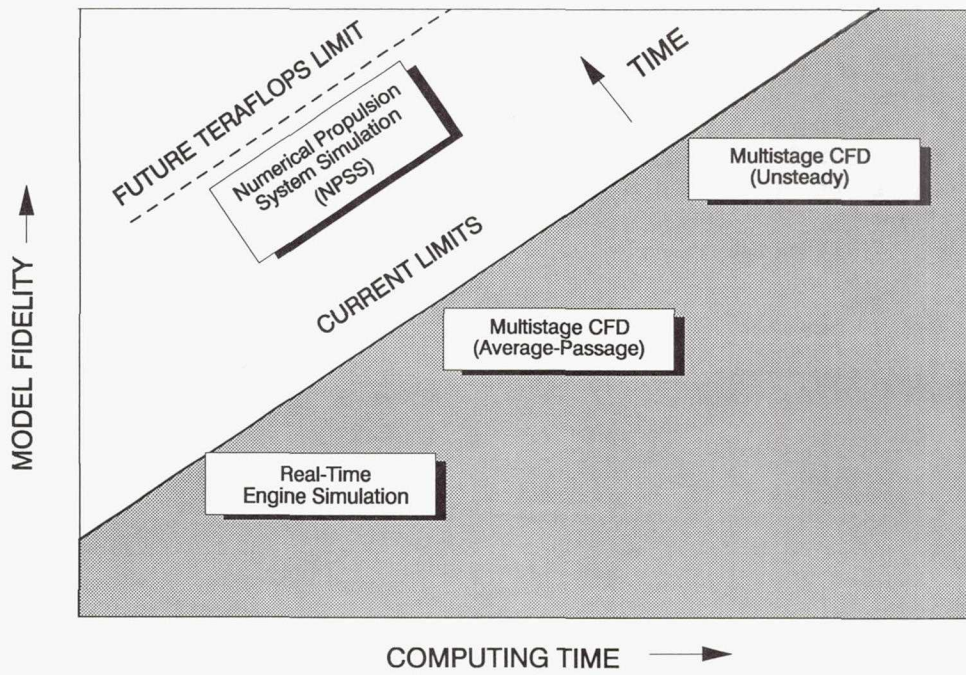

Figure 3.—Computer-imposed limits on CFD models for propulsion analysis.

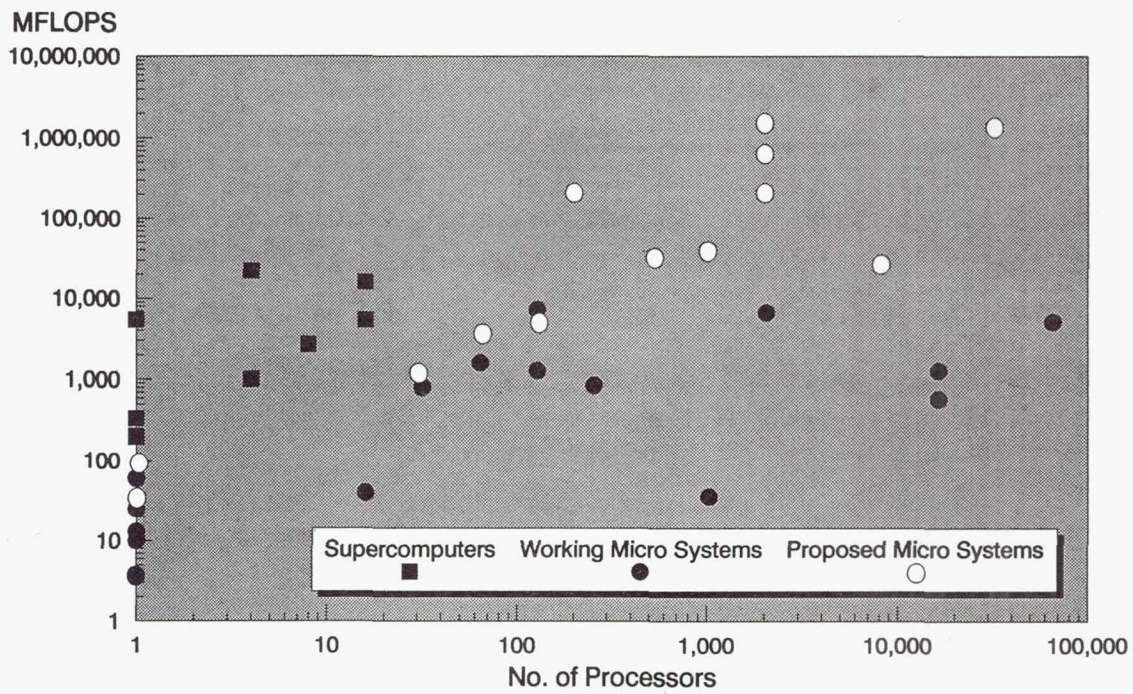

Figure 4.—Peak performance of high-performance computers.

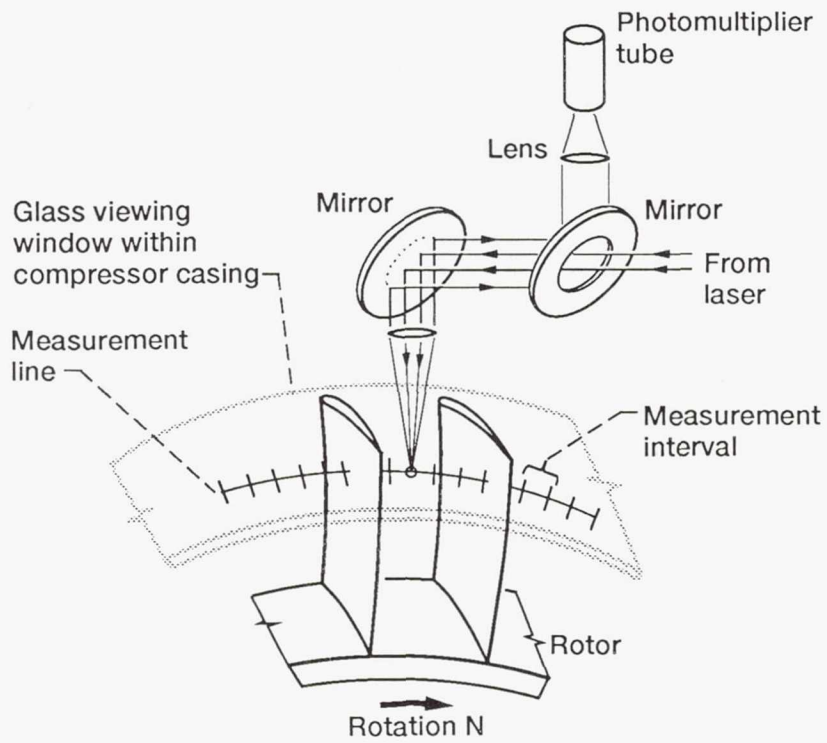

Figure 5.—Laser anemometer measurements of compressor flow velocities.

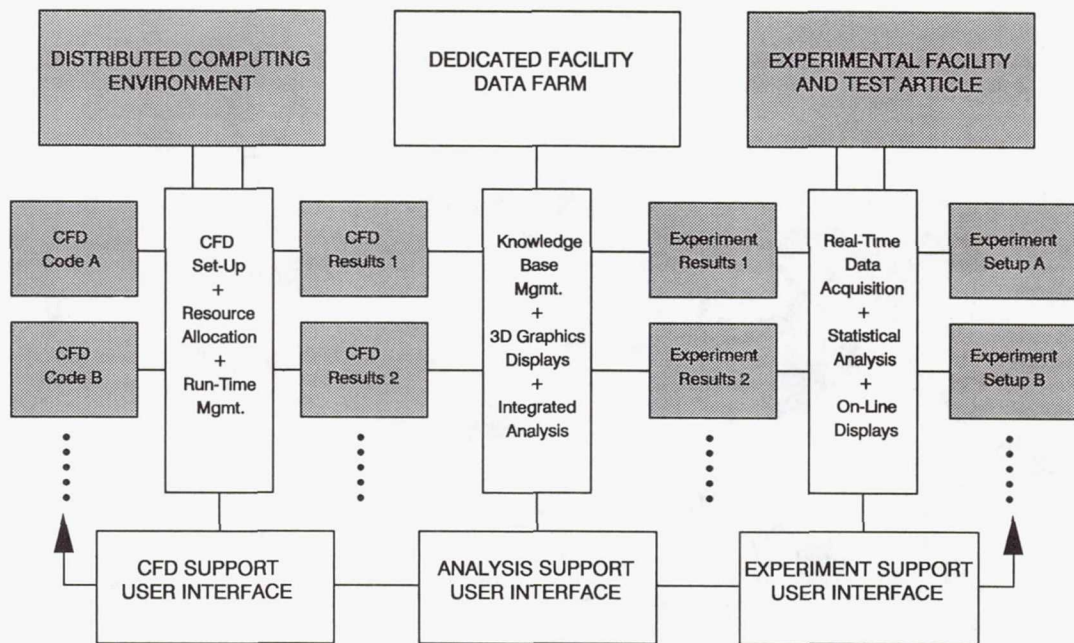

Figure 6.—ICE system architecture.

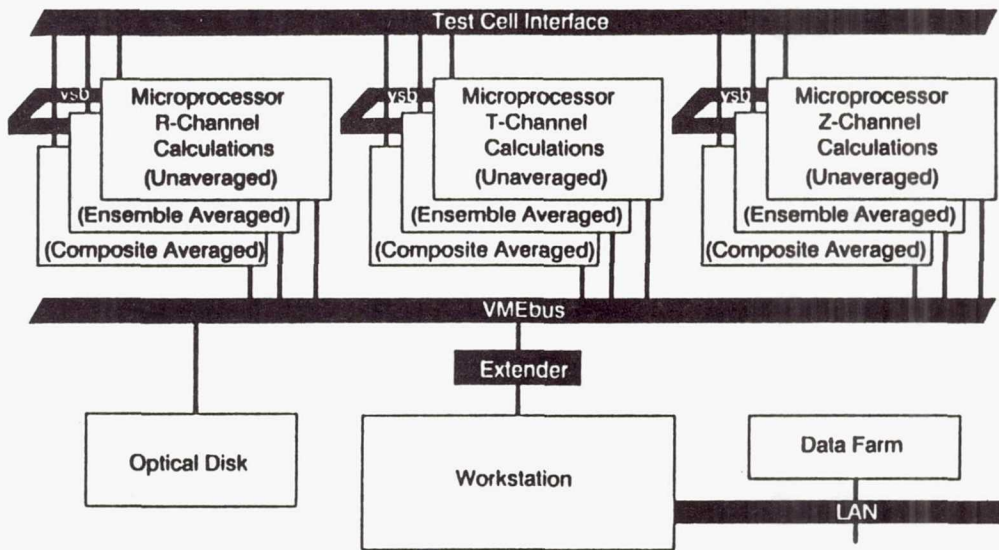

Figure 7.—ICE experiment support subsystem —parallel processing of measurements.

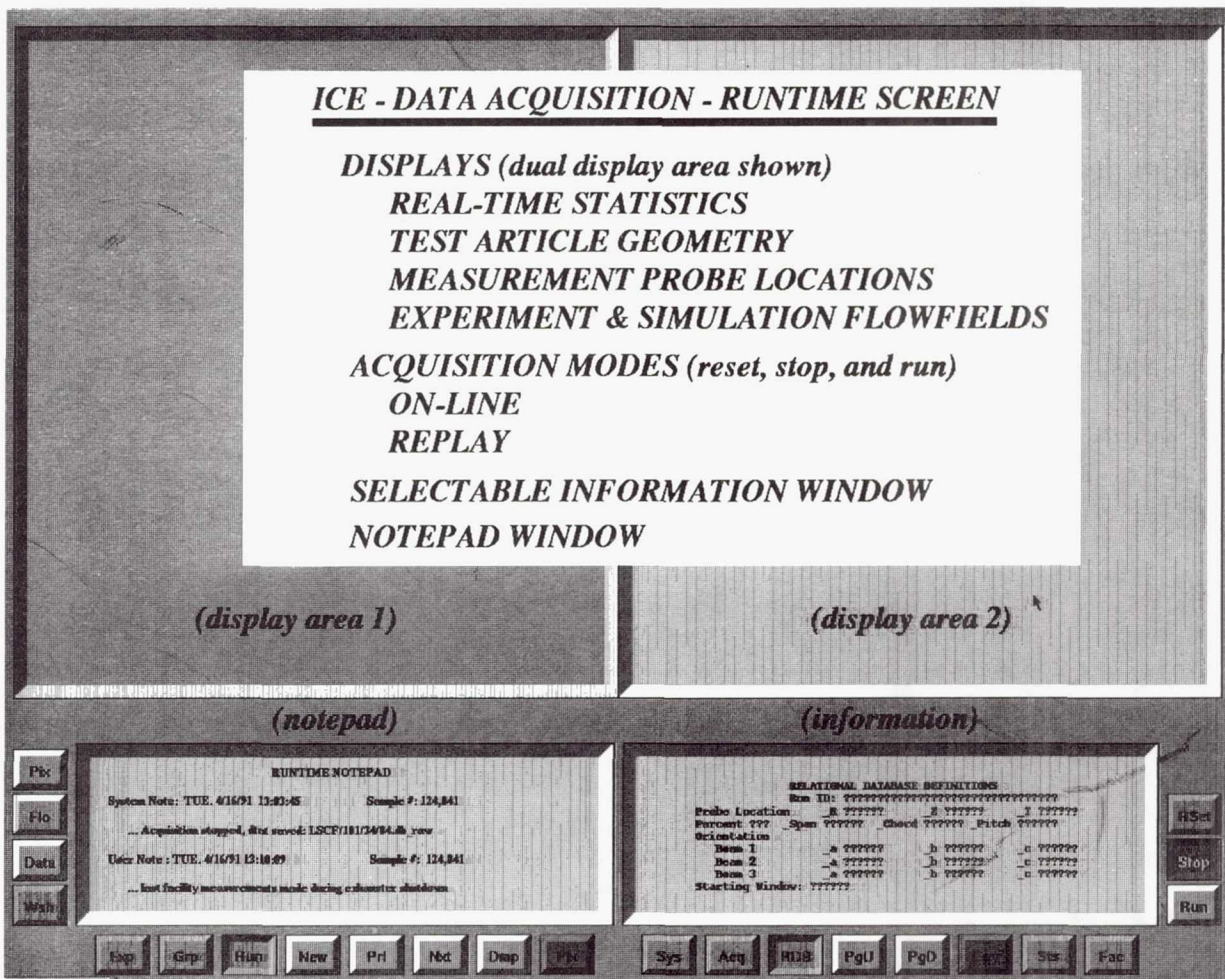

Figure 8.—ICE experiment support subsystem – user interface screen.

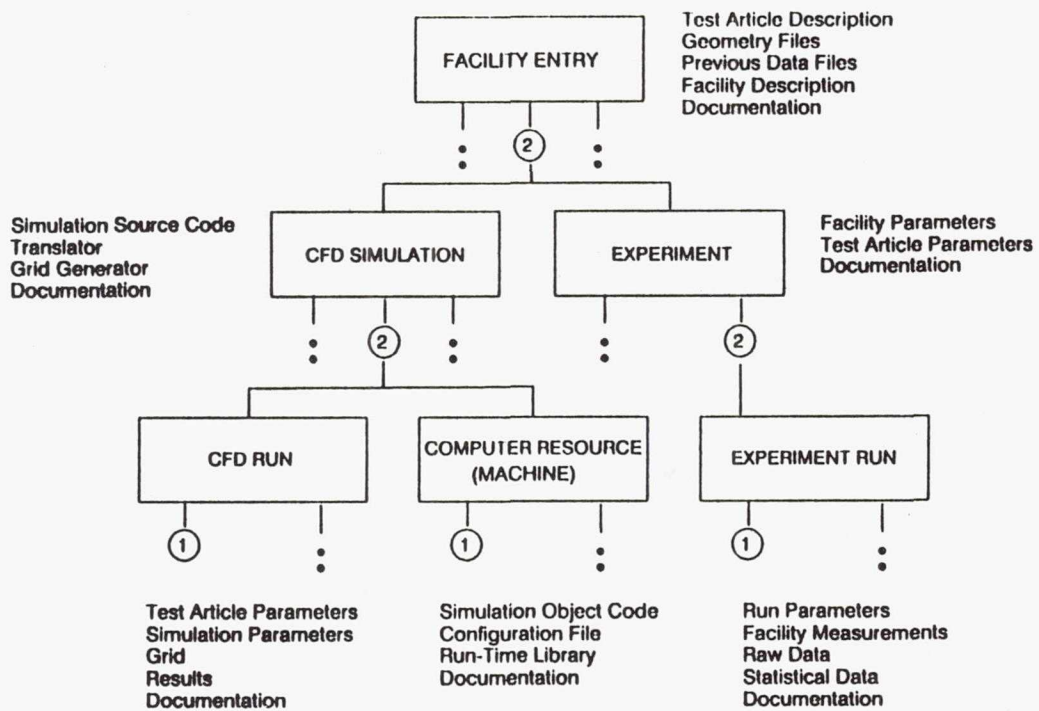

Figure 9.—Structure of ICE knowledge base.

Report Documentation Page

1. Report No. NASA TM - 104374		2. Government Accession No.		3. Recipient's Catalog No.	
4. Title and Subtitle Enhancing Aeropropulsion Research With High-Speed Interactive Computing				5. Report Date	
				6. Performing Organization Code	
7. Author(s) John R. Szuch, Dale J. Arpasi, and Anthony J. Strazisar				8. Performing Organization Report No. E - 6179	
				10. Work Unit No. 505 - 10 - 03	
9. Performing Organization Name and Address National Aeronautics and Space Administration Lewis Research Center Cleveland, Ohio 44135 - 3191				11. Contract or Grant No.	
				13. Type of Report and Period Covered Technical Memorandum	
12. Sponsoring Agency Name and Address National Aeronautics and Space Administration Washington, D.C. 20546 - 0001				14. Sponsoring Agency Code	
15. Supplementary Notes Prepared for the 10th International Symposium on Air Breathing Engines sponsored by the American Institute of Aeronautics and Astronautics, Nottingham, England, United Kingdom, September 1 - 6, 1991. Responsible person, John R. Szuch, (216) 433 - 3856.					
16. Abstract The NASA Lewis Research Center has committed to a long-range goal of creating a numerical "test cell" for aeropropulsion research and development. Efforts are underway to develop a first-generation Numerical Propulsion System Simulation (NPSS). The NPSS will provide a unique capability to numerically simulate advanced propulsion systems from "nose to tail". Two essential ingredients to the NPSS are: (1) experimentally-validated CFD codes and (2) high-performance computing systems (hardware and software) that will permit those codes to be used efficiently. To this end, the NASA Lewis Research Center is using high-speed, interactive computing as a means for achieving Integrated CFD and Experiments (ICE). This paper describes the development of a prototype ICE system for multi-stage compressor flow physics research.					
17. Key Words (Suggested by Author(s)) Simulation; Computers; Propulsion; Parallel processing (computers); Data processing; Fluid dynamics				18. Distribution Statement Unclassified - Unlimited Subject Category 62	
19. Security Classif. (of the report) Unclassified		20. Security Classif. (of this page) Unclassified		21. No. of pages 18	22. Price* A03