

IN-35

24763

P, 24

NASA CASE NO. MFS-28563-1
 PRINT FIG. #1

NOTICE

The invention disclosed in this document resulted from research in aeronautical and space activities performed under programs of the National Aeronautics and Space Administration. The invention is owned by NASA and is, therefore, available for licensing in accordance with the NASA Patent Licensing Regulation (14 Code of Federal Regulations 1245.2).

To encourage commercial utilization of NASA-owned inventions, it is NASA policy to grant licenses to commercial concerns. Although NASA encourages nonexclusive licensing to promote competition and achieve the widest possible utilization, NASA will consider the granting of a limited exclusive license, pursuant to the NASA Patent Licensing Regulations, when such a license will provide the necessary incentive to the licensee to achieve early practical application of the invention.

Address inquiries and all applications for license for this invention to NASA/Marshall Space Flight Center, Patent Counsel, Mail Code CC01, Marshall Space Flight Center, AL 35812. Approved NASA forms for application for nonexclusive or exclusive license are available from the above address.

Serial Number 07/710193

Filing Date June 3, 1991

NASA/MSFC

(NASA-Case-MFS-28563-1) RADIATION SENSITIVE
 AREA DETECTION DEVICE AND METHOD Patent
 Application (NASA) 24 p CSCL 148

N91-25388

Unclass

63/35 0024763

TECHNICAL ABSTRACT

RADIATION SENSITIVE AREA DETECTION
DEVICE AND METHOD

The present invention is directed to an radiation sensitive area detection device of high spatial resolution which employs a phosphor-containing film plate capable of storing the image produced by the incoming X-rays or other radiation, a laser light source, an optical fiber that projects the laser light onto the film and which receives fluoresced light from the film, and an intergrating sphere which receives fluoresced light from the fiber and directs it to signal processing. The device is particularly advantageous in that the optical fiber can be placed very close to the phosphor-containing film, and a near real-time image of an X-ray diffraction pattern can be obtained efficiently and with high spatial resolution.

The radiation sensitive detection device 10 comprises a helium-neon laser light source 12, a phosphor-containing imaging plate or screen 20, an optical fiber 16 for channeling the light from the laser light source to the screen and a integrating sphere 14 which receives and transmits the fluoresced light to a signal processing means including light receiving means such as photomultiplier tube 30. In operation, an X-ray or other radiation pattern is absorbed on the phosphor-containing film 12, and this stored image is caused to fluouresce by the stimulation of light from laser light source 12 which travels via optical fiber 16 onto the phosphor screen 20. The optical fiber 16 is controlled by means of a highly polished thin metal holder 18, and the fiber is maneuvered horizontally and vertically across the phosphor screen by means of servo motor-driven stages 22 and 24. After stimulation of light causes the phosphor screen to fluouresce, the fluoresced light

travels back through optical fiber 16 and into integrating sphere 14, where it becomes focused upon the light receiving means such as photomultiplier tube 30. From the photomultiplier tube, the light signal is processed preferably using discriminator 34, counter circuit 36 and computer 40. The operation of the present invention allows for producing a near-real-time image of an X-ray or other radiation diffraction pattern with high efficiency and excellent spatial resolution, and without the distortion of prior art devices.

The novelty of the invention appears to lie in the configuration of the device which allows the optical fiber 16 to be placed very close to phosphor screen 20, uses the same optical fiber to direct light onto the screen and receive the fluoresced light, and which uses an integrating sphere to focus the fluoresced light onto a photomultiplier tube where it is further processed to detect the X-ray diffraction pattern stored on the screen. The device allows for a high resolution, near-real time image using a side-by-side scanning procedure which avoids prior art problems including skewed-shaped pixels on the outer edges of the scan, and problems related to spontaneous fluorescence from outer regions of the phosphor screen which previously contributed to unwanted background noise.

Inventors: Daniel C. Carter, Diana L. Hecht, and
William K. Witherow

Employer: NASA/MSFC

Filing Date: June 3, 1991
Serial Number: 07/710193

NASA MFS 28563-1

RADIATION SENSITIVE AREA DETECTION
DEVICE AND METHOD

ORIGIN OF THE INVENTION

5 The invention described herein was made by employees of the United States Government and may be manufactured and used by or for the government for governmental purposes without the payment of any royalties thereon or therefore.

FIELD OF THE INVENTION

10 The invention relates to a radiation-sensitive area detection device for use in conjunction with X-ray, ultraviolet, or other radiation sources which uses a phosphor-containing film to store an X-ray image and transmit that image when stimulated by light, an
15 optical fiber which projects light on the film and directs the fluoresced light to an integrating sphere, and a signal processing means which converts the fluoresced light into a high-resolution image of the diffraction pattern originally formed on the phosphor-
20 containing film. The invention also relates to a method of obtaining a high resolution radiation diffraction image using this device.

BACKGROUND OF THE INVENTION

25 Radiation area detector systems have become a valuable tool for experimentation and research in a wide variety of scientific and medical applications. Over the past few years, these detectors have become increasingly important as analytical and diagnostic devices which are used in such diverse fields as
30 crystallography, medical radiography, electron microscopy, biophysics, and even astronomy. Previously, these area detection devices generally fell into either of two distinct types: (1) the multi-wire

proportional counter, such as described in Bateman et al, Nuc. Inst. Meth. Phys. Res. A259: 506-520 (1987), and (2) the T.V. detector such as disclosed in Kalata, Methods in Enzymology 114: 486-510 (1985). These two
5 types of area detection devices are still used today in various applications.

These previous devices, however, have suffered from several drawbacks. In particular, they are often extremely limited in terms of active area and spatial
10 resolution, and often experience high levels of spatial distortion and non-uniformity of response. The devices also generally require a prolonged exposure to X-rays in order to develop a satisfactory picture. In cases where an instantaneous image of a rapidly deteriorating
15 sample is required, these prior art systems have not been rapid enough to provide near real time images, and thus are not suitable for such an application.

In the field of protein crystallography, instantaneous imaging is almost always necessary, and a
20 device that can provide near real time images is often required. During crystal growth, protein single crystals are grown so that the three-dimensional structure of the protein can then be determined by X-ray or other radiation diffraction patterns. Typically, these grown protein crystals deteriorate
25 very rapidly with increasing time and handling, and the specific details of the protein structure will often be lost if an X-ray pattern from the crystals cannot be obtained within an extremely short period after their
30 formation. It is thus extremely important to develop systems for area detection which have rapid data acquisition and which can provide near real time imaging capabilities for X-ray diffraction patterns.

A relatively recent discovery of the unique properties of certain phosphor-containing films has enabled new developments in X-ray and ultraviolet-sensitive area detection devices. In particular, it has been found that a plate containing a barium fluorohalide (such as BaFX:Eu) crystal will absorb a particular fraction of incident X-ray or UV radiation by "trapping" an electron in a halogen ion vacancy or "F-center". Electrons so trapped will normally be stored at a half life of approximately 10 hours. However, if the film containing the trapped electrons is irradiated with visible light, the electrons in the F-center will be liberated to the conduction band which leads to the formation of Eu^{+2} ions in an excited state. These excited ions then relax to give off luminescence in proportion to the intensity of the X-ray or UV radiation originally absorbed by the film. It is thus possible through the use of such film to create a stored or latent image on the film which can almost instantaneously be dumped or otherwise transmitted to an image translation means by subsequent illumination of the film by an appropriate wavelength of light or other electromagnetic wave. Further, after the dumping of the image, the phosphor film will return to its original state so as to be reusable for further X-ray imaging.

Devices incorporating such a phosphor-containing film are also known in the art. An example of one is found in Miyahara et al, Nuc. Inst. Meth. Phys. Res. A246: 572-578 (1986), and this device essentially consists of a barium fluorohalide phosphor screen imaging plate, a laser beam reflected by a scanning mirror, a light guide for collection of the photostimulated luminescent radiation, and a tube for collecting the fluoresced light. In this device, an

He-Ne laser beam emitting light at about 632 nanometers is reflected by the mirror and used to illuminate the film which luminesces at around 390 nm in response to the laser stimulation. Another area detection device is also disclosed in U.S. Patent No. 4,933,558 (Carter et al), incorporated herein by reference, wherein a light source either directly or through a mirror illuminates the phosphor-containing film storing the X-ray image, and the fluoresced light is focused upon a charged coupled detecting element by means of a lens or an optical fiber bundle in the shape of a half-hour glass. Both of these devices can be used to scan the film line-by-line, but are limited in that the pixel resolution obtained in the line scan cannot be easily changed.

There are still other problems with prior art side-by-side scanning devices which have restricted their effectiveness. One such problem is that they tend to create skewed-shaped pixels on the outer edges, and there often are problems relating to spontaneous fluorescence which contributes to unwanted background noise. In addition, it is preferred that the means to illuminate the phosphor-containing film be physically as close to the film as possible, yet this is hard to accomplish using any of these prior devices. It is also desirable to accomplish injection and detection of the excitation and fluoresced radiation along the same optical path in order to maximize the efficient transmission of light and ensure a high spatial resolution in the scanning device.

It is thus a desirable object to develop an X-ray, UV or other radiation sensitive area device of high spatial resolution that can utilize a phosphor-containing film in a manner which allows for line-by-line scanning with easy manipulation of pixel

resolution, injection and detection of excitation and fluorescence using the same optical pathway, and the placement of the illuminating light source as physically close to the phosphor film as possible. A
5 device utilizing these features can be used successfully to produce near real time images of high spatial resolution from rapidly deteriorating samples such as would be involved in research in the field of protein crystallography.

10 SUMMARY OF THE INVENTION

In accordance with the present invention, a radiation-sensitive area detection device for use in conjunction with X-ray, ultraviolet, or other radiation source is provided which comprises:

15 a) a phosphor-containing film capable of receiving and storing an image formed by the pattern of incoming radiation falling on the film after deflection or transmission through a sample, and capable of fluorescing this pattern in response to stimulation
20 from light or other electromagnetic wave;

b) a light source capable of projecting light or other electromagnetic wave upon said phosphor-containing film so as to cause said film to fluoresce in proportion to the stored image formed by the pattern
25 of incoming radiation falling on the film;

c) an optical fiber capable of being positioned directly in front of the phosphor-containing film and capable of directing a variable amount of light or other electromagnetic wave from the light source onto
30 the phosphor-containing film so that said film fluoresces in proportion to the stored image and the fluoresced light travels back along said fiber to an integrating sphere capable of directing the light to a signal processing means;

d) an integrating sphere having a reflective inner surface capable of receiving the fluoresced light from said optical fiber and capable of directing said fluoresced light to a signal processing means; and

5 e) a signal processing means comprising a light receiving means capable of receiving the fluoresced light from said integrating sphere and transmitting a signal corresponding to the amount of fluoresced light from the phosphor-containing film to a signal
10 translation means and a signal translation means capable of translating the signal received from said light-receiving means to allow detection of the pattern formed on the phosphor-containing film as a result of incoming radiation falling on said film after
15 deflection or transmission through a sample.

The optical fiber is preferably held directly in front of the phosphor-containing film by means of a spring-loaded thin metal holder that can be moved horizontally or vertically across the phosphor-
20 containing film by motor-driven stages. Additionally, it is preferred that the holder contain a pinhole through which the light passing through the optical fiber can be varied before being directed onto the phosphor film. It is preferred that a photomultiplier
25 tube be employed as the light-receiving means of the invention. The detection device of the present invention is preferably retained in a light-proof compact housing which will ensure the high efficiency and superior spatial resolution. A method is also
30 provided for obtaining a near real time image of an X-ray or ultraviolet diffraction pattern of a sample utilizing this device.

BRIEF DESCRIPTION OF THE DRAWING FIGURES

Figure 1 is a perspective schematic view of an area detector in accordance with the present invention;

5 Figure 2 is a top cutaway view of an optical fiber used in accordance with the device of the present invention;

DETAILED DESCRIPTION OF THE PREFERRED EMBODIMENTS

10 According to the present invention, a radiation-sensitive area detection device for use in conjunction with an X-ray, ultraviolet or other radiation source, is provided, such as can be observed in the schematic drawing Figure 1. The device 10 primarily consists of a light source such as helium-neon laser 12 which directs light into and through integrating sphere 14 by
15 means of an optical fiber 16. The optical fiber 16 directs the light from the light source directly onto phosphor-containing film or imaging plate 20, and by moving the optical fiber across the phosphor film 20, a complete pattern of the image stored in the film can be
20 obtained.

In order to move the optical fiber 16 vertically and horizontally across the phosphor-imaging plate 20, means are provided such as servo-motor driven stages 22 and 24 which are connected to a fiber-optic holder 18
25 preferably made of a suitable highly polished thin metal, Teflon (polytetrafluoroethylene), or other suitable materials. The highly polished metal holder is preferred because it can be machined much thinner than the Teflon. The vertical servo-motor driven stage
30 22 is provided to move the optical fiber up and down vertically across the phosphor plate 20, and the

horizontal stage 24 is provided to move the fiber-optic holder 18 across plate 20 horizontally. If so desired, stepping motors can be used in place of the servo-motors.

5 In the preferred embodiment, both horizontal (or X-axis) stage 24 and vertical (or Y-axis) stage 22 have 250 mm travel capacity, at least 100 micron resolution, and are configured with incremental encoders and origin switches located at the motor end. By having both
10 stages motored by DC servo motors, one is able to use a controller with faster translation speeds and better control over specific parameters such as the PID (Proportional, Integral, Derivative) filters. Suitable for use as the horizontal or vertical stage is the MT
15 160.250 (354062) stage from the Klinger Scientific Corporation. Ideally, both motors are driven by servo motors can be controlled using a controller such as the DCS 750 Motor controller/driver. The stages can be
20 mounted by means of a mounting bracket such as the EQ 160 mounting bracket also produced by the Klinger Scientific Corp.

 If desired, one or both axis stages can also be powered by stepping motors to allow stepwise scanning across phosphor plate 20. In such a configuration, a
25 stepping motor-driven stage (not shown) such as the MT 160.200 (354085) stage available from the Klinger Scientific Company can be used that is connected to a stepping motor such as a VE 73PP series stepping motor.

 It is preferred that the translation stage 24 used
30 for the X-axis be equipped with a 2000 point shaft encoder, with each encoder pulse corresponding to about 10 microns. This configuration will allow the resolution to be adjusted in 10 micron steps. If the circuit is set to latch the count every 10 pulses, then
35 the resolution will be 100 microns. Accordingly, if

D.C. 5-28-71
W.K.W. 5-28-71
D.H. 5-28-71

the circuit is set to latch the ^{count}~~count~~ every 5 pulses,
the resolution will be 50 microns. It is also
preferred that the translation stage 22 used for the y-
axis be equipped with a 200 point shaft encoder, with
5 each encoder pulse corresponding to about 100 microns.
This configuration will allow for enhanced speed
capability for the scanning process.

In the preferred embodiment, the integrating
sphere 14 has portholes 26 and 28 which provide a
10 pathway for the optical fiber 16 to direct the light
from the light source 12 which travels through sphere
14, and which is directed onto the phosphor film 20 via
fiber-optic holder 18. After the phosphor film is
15 stimulated, the fluoresced light from the film travels
back through the optical fiber 16 and into the
integrated sphere 14 through porthole 28. The
integrating sphere preferably has an inner surface that
reflects at least about 95% and preferably about 98% of
the incoming light. The inner surface of the
20 integrating sphere can be coated with a roughly 98%
reflective paint, such as Kodak reflective paint,
having optional reflection preferably in the 400 nm
range. This will ensure proper reflectivity from the
integrating sphere to a light receiving means.
25 Suitable for use as the integrating sphere is the Model
No. 27-5560-01 available from Ealing Electro-Optics,
Inc.

Connected to integrating sphere 14 is a light
receiving means, preferably photomultiplier tube 30,
30 which is connected at porthole 32 to the interior of
sphere 14. Many other suitable light-receiving means
that are well known in the art, such as those disclosed
in U.S. Patent 4,933,558, can also be employed in the
invention. In the preferred embodiment,
35 photomultiplier tube 30 will have a peak wavelength and

high quantum efficiency at around 400 nanometers so as to best detect the fluoresced light. After receiving the fluoresced light from the integrating sphere, the photomultiplier tube will then transmit a signal
5 corresponding to the amount of fluoresced light received from the phosphor film 20 to the signal translation means. A photo multiplier tube with peak efficiency at around 400 nanometers is the Model No. R647-04 available from the Hamamatsu Corporation which
10 is suitable for use in the invention.

The signal processing means of the invention includes a light receiving means such as tube 30 and a signal translation means which is employed to detect the pattern originally formed on the phosphor film as a
15 result of incoming radiation falling on the film after deflection or transmission through a sample. In the preferred embodiment, the photomultiplier tube 30 transmits a pulsed signal in proportion to the fluoresced light that is emitted by the phosphor film
20 following stimulation by light source 12. This pulsed signal is transmitted to the signal translation means which in the preferred setup comprises a pulse preamplifier discriminator 34 that receives the pulses from the photomultiplier tube and outputs a signal that
25 can be counted. Suitable as the discriminator is the F-100 T available from Modern Instrumentation Technology, Inc. which outputs TTL signals in response to the photomultiplier pulses. Additionally, the signal translation means comprises a counting circuit
30 36 which receives signals from the discriminator 34. This counting circuit preferably uses encoder pulses from the motor driven stages 22 and 24 in order to determine the location of a particular data point and to provide for various step sizes depending on the

desired resolution (generally from about 50-100
microns). Counting circuit 36 also counts the light
pulses at each step and sends the count to computer 40,
the final element of the signal translation means, for
5 storage, image generation, or further numerical
analysis.

The device 10 will also preferably include an
outer light-proof housing 38 so as to eliminate
undesirable background light and maximize the
10 efficiency of the detection device. It is also
preferred that a secondary light source 42 be provided
which is capable of completely releasing any remaining
radiation in the phosphor film after the main scanning
is finished.

15 The phosphor film 20 of the present invention will
be one that can absorb incoming radiation so as to
retain a latent image of a diffraction pattern formed
after radiation, such as X-rays or ultraviolet rays are
transmitted or deflected by a sample such as a protein
20 crystal. It is preferred that films containing barium
fluorohalide crystals be used as the phosphor film in
the present invention. Most preferred are films or
plates containing a BaFBr:Eu²⁺ photostimulable phosphor
which have been most successful when used in the
25 present device. Other barium fluorohalide crystals
such as BaFCl have also been suitably used as phosphors
in the plate 20. Any other film that fluoresces in
proportion to the stored radiation in response to
stimulation by light may also be used in the invention.

30 In the preferred method of the invention, a
radiation diffraction image pattern is first stored in
the phosphor film, such as in the manner described
previously in U.S. patent 4,933,558, before light from
light source 12 is directed onto phosphor film 20 to
35 cause it to fluoresce and release this pattern. In

this scheme, radiation such as X-rays or ultraviolet light is directed to pass through a sample container such as a capillary tube which contains a crystal or other object to be studied. The container is generally
5 situated on a goniometer (or crystal positioner) which can ensure a 360° rotation of the chamber and produce a radiation diffraction pattern from the crystal onto the phosphor-containing film 20. The diffraction pattern will be stored in the phosphor film until the image is
10 released by light stimulation causing the phosphor to fluoresce.

When "dumping" or translation of the latent image stored by the phosphor film is desired, it is necessary to illuminate the film with a suitable source of light
15 or other appropriate electromagnetic wave. When the light source is an He-Ne laser light directed at the phosphor screen from the laser will cause the stored image to be released and the phosphor film will fluoresce at a wavelength of approximately 400
20 nanometers. In the preferred embodiment of the present invention, after the phosphor luminesces in response to the laser light, the light is collected via the same optical fiber that carried the laser beam onto the phosphor film. This light is carried back along
25 the optical fiber to the integrating sphere where it is reflected into the photomultiplier tube. Preferably, the photomultiplier tube is protected from the original laser beam by a filter which prevents the 633 nanometer wavelength from entering and damaging it. The inner
30 reflective coating of the integrating sphere as well as its shape minimizes the amount of light lost from the fluoresced light travelling along the optical fiber before being collected by the photomultiplier.

5 The optical fiber 16 that is used in the present invention thus must be capable of transmitting the beam from the light source such as He-Ne laser 12 onto phosphor screen 20 and at the same time channel fluoresced light from the screen back to the integrating sphere where it will be collected by photomultiplier tube 30. It is preferred that a high numerical aperture optical fiber comprised ^{of} ~~en~~ silica (preferably in pure-form) and capable of transmitting 10 wavelengths from between about 390-650 nm be employed in the present invention. Another suitable optical fiber is the HCS HCN/H optical fiber produced by the Ensign-Bickford Optics Company. This type of fiber will allow the approximately 633 nm wavelength 15 transmitted by the He-Ne laser light source to impinge upon the phosphor film 20 so as to cause fluorescence, while at the same time act to transmit the fluoresced light from the phosphor film which will be at a wavelength of approximately 400 nm.

20 It is important for the optical fiber 16 to be placed directly in front of the phosphor screen 20 and to be moved across the screen in such a manner as to obtain a high resolution pattern of the image formed on the screen with a minimum of distortion. Accordingly, 25 it is preferred that a spring-loaded holder 18 be used with the fiber-optic system of the present invention. This holder is preferably constructed out of a highly polished thin machined metal or Teflon so that it can be moved across the phosphor film without causing any 30 damage. A number of suitable metals can be used to construct the holder, as will be apparent to one skilled in th art. It is also possible that this holder can be comprised of a thin light-weight metal or other materials which have been coated with Teflon and 35 which are suitable for use in the invention. The

D.C. 5-28-91
W.K.W. 5-28-91
D.H. 5-28-91

holder 18 in conjunction with a fiber-optic assembly is best observed in Figure 2. The fiber-optic assembly 50 is comprised of an optical fiber 16 which is made up of a central core region 17 (normally about 300 microns) and an outer cladding 19 made of a high NA bonded hard polymer or other suitable materials.

The fiber 16 is thus constrained by means of the optical fiber holder 18 which is made of thin machined metal, Teflon or Teflon-coated material as indicated above. As shown in Fig. 2, the holder is characterized by a fiber optic chuck 52 which is centrally located in the holder and which retains optical fiber 16 in place. At the end of the optical fiber 16 that will be directly in front of the phosphor screen 20, there is a pinhole 54 which determines the resolution of the beam of incoming light. This pinhole 54 is preferably removable so that a variety of differently-sized pinholes, such as 50 microns, 100 microns, etc., can be used depending on the particular resolution that is sought. This replacable pinhole 54 allows quick adjustment of resolution so that the device of the present invention can be readily converted for a variety of different scannings. In the preferred embodiment, the device employs a pinhole made from a filter which passes only 400 nm light. In this configuration, the laser beam is sent through the central pinhole (e.g., at 50 or 100 micron diameter), and the fluoresced light is received over the entire face of the pinhole.

In the preferred method of carrying out the present invention, a diffraction image is stored on phosphor film 20 after a sample is impinged by X-rays, ultraviolet, or other radiation as described above. While the original diffraction image is formed on the phosphor screen 20, the fiber-optic holder and the

translation stages are moved to one side so as to not interfere with the projection and retention of the original pattern. Once the image is stored by the phosphor-containing film, the scanning to reveal that
5 image can begin.

In the preferred embodiment, a beam of He-Ne laser light from light source 12 is used to cause the phosphor screen 20 to luminesce in proportion to the amount of light stored at each location. The light
10 from laser 12 is transmitted along optical fiber 16 which passes through integrating sphere 14 and is channeled directly onto the phosphor screen by means of the fiber-optic holder 18. The phosphor screen 20 will luminesce in response to the laser light, and this
15 light is collected using the same optical fiber assembly that carried the laser beam. The high numerical aperture of the fiber and the positioning of the fiber directly on the phosphor ensure that the maximum number of photons from the screen are received.
20 The desired resolution can be obtained by choosing a pinhole having a particular size which will be controlled by holder 18. Preferably, a 100 micron resolution pinhole will be employed which will be suitable for many applications, but if necessary, this
25 resolution can be changed by using a pinhole having a different width, e.g., about 50 microns.

The scanning of the image is accomplished by moving the fiber-optic holder 18 by means of the motor driven stages 22 and 24. The stages are used to
30 position the fiber-optic holder 18 containing optical fiber 16 which both transmits the laser beam and receives the illuminated light. When scanning is about to be accomplished, the holder 18 is preferably positioned at the lower left-hand corner of the film.
35 The translation of the image is preferably accomplished

by moving the fiber-optic holder from the lower edge to the upper edge of the film, then moving it horizontally one unit or step to the side, followed by moving the vertical stage back to the lower edge of the screen, 5 stepping another horizontal step to the side, and repeating these steps until the film has been completely scanned by the fiber-optic holder 18. The upward and downward movement of the fiber-optic holder 18 accomplishes scanning without the prior art problems 10 which accompanied previous side-to-side scanners. In those prior art devices, side-to-side scanning created skewed-shaped pixels on the outer edges. As a further advantage of the present device, the particular scanning system of the invention eliminates any 15 spontaneous fluorescence from other regions of the phosphor which previously would have contributed to unwanted background noise.

In the present method, the fluoresced light is carried back through optical fiber 16 to the integrated 20 sphere 14 through porthole 28 where it is reflected onto the photomultiplier 30 connected at the side of the sphere. It is preferred that the photomultiplier be protected from the original laser beam by a filter (not shown) which prevents the 633 nm wavelength from 25 entering and damaging the tube. The sphere 14 has been designed with an inner reflective coating so as to minimize the amount of light lost that enters the sphere before being collected by the photomultiplier. In the preferred embodiment, the photomultiplier pulses 30 in response to the incoming light, and the output signal is then sent through a pre-amplified discriminator 34 and a counter circuit 36. The photon count from the photomultiplier which is sent to the discriminator is converted into TTL-level pulses. The 35 pulses are sent from the discriminator to counter

circuit 36 which counts the signals and then sends the number to a computer 40 via a parallel input/output board where the signals can be translated, stored, or processed^d further. The circuit which is used to count the light pulses received from the photomultiplier tube and amplifier system is also preferably used to count encoder pulses from the shaft encoder mounted along with the vertical DC servo-motor driven stage 22. In this configuration, the vertical stage is driven by a faster servo-motor rather than a stepwise motor, which reduces the total time needed for the scan. The encoder pulses received from the motor driven stages can be used to establish the exact position of the holder 18 when the light pulses received from the phosphor-containing film are counted. In a preferred mode, each pulse of the encoder from the vertical stage corresponds to about 100 microns, and to about 10 microns per pulse from the horizontal stage, but the resolution can be changed easily by changing the number of encoder pulses counted before the light-pulse count is latched and sent to the computer.

After the scan is finished, the fiber-optic holder can again be moved to the side to allow a second diffraction pattern to be stored by the phosphor-containing film. It is preferred that before a second image is projected onto the phosphorfilm, any remaining light that may be stored in the film should be released by flashing a bright light 42 which is mounted inside housing 38 which surrounds the scanning apparatus. In this manner, the film can be completely cleaned of the original pattern, and be made ready to store a second image. When a second diffraction image is stored in the film, the entire translation process can be repeated as indicated above. In this manner, a near

D.C. 5-28-71
W.K.W. 5-28-71
D.H. 5-28-71

real time image of high spatial resolution can be obtained without the distortions or problems in prior art systems employing photomultiplier tubes.

5 Other features and advantages inherent in the above disclosure will be obvious to those skilled in the art, and it is clear that a variety of alternate embodiments can be employed without departing from the scope of the present invention. For example, it is possible that instead of an integrating sphere, an
10 integrating cylinder, such as produced by Molecular Dynamics of Palo Alto, California, can be coupled to the scanning assembly and used in the processing of the signal corresponding to the fluoresced light from the phosphor-containing film. It is also possible to use
15 the detecting assembly of the present invention in drum scanner configurations. As a further embodiment of the present invention, it is sometimes desirable to cool the imaging plate by using a suitable thermoelectric device which can further reduce the problem of
20 spontaneous fluorescence and increase the efficiency of the scanning of the phosphor-containing film. In all of these embodiments, the present invention will provide a method and apparatus for obtaining X-ray and other radiation diffraction images of high quality,
25 high spatial resolution, and low distortion, on a near real time basis.

ABSTRACT OF THE DISCLOSURE

A radiation-sensitive area detection device for use in conjunction with an X-ray, ultraviolet or other radiation source is provided which comprises a
5 phosphor-containing film which releases a stored diffraction pattern image in response to incoming light or other electromagnetic wave, a light source such as a helium-neon laser, an optical fiber capable of directing light from the laser source onto the phosphor
10 film and also capable of channelling the fluoresced light from the phosphor film to an integrating sphere which directs the light to a signal processing means including a light receiving means such as a photomultiplier tube. The signal processing means
15 allows translation of the fluoresced light in order to detect the original pattern caused by the diffraction of the radiation by the original sample. The optical fiber is retained directly in front of the phosphor screen by a thin metal holder which moves up and down
20 across the phosphor screen and which features a replaceable pinhole which allows easy adjustment of the resolution of the light projected onto the phosphor film. The device produces near real time images with high spatial resolution and without the distortion that
25 accompanies prior art devices employing photomultiplier tubes. A method is also provided for carrying out radiation area detection using the device of the invention.

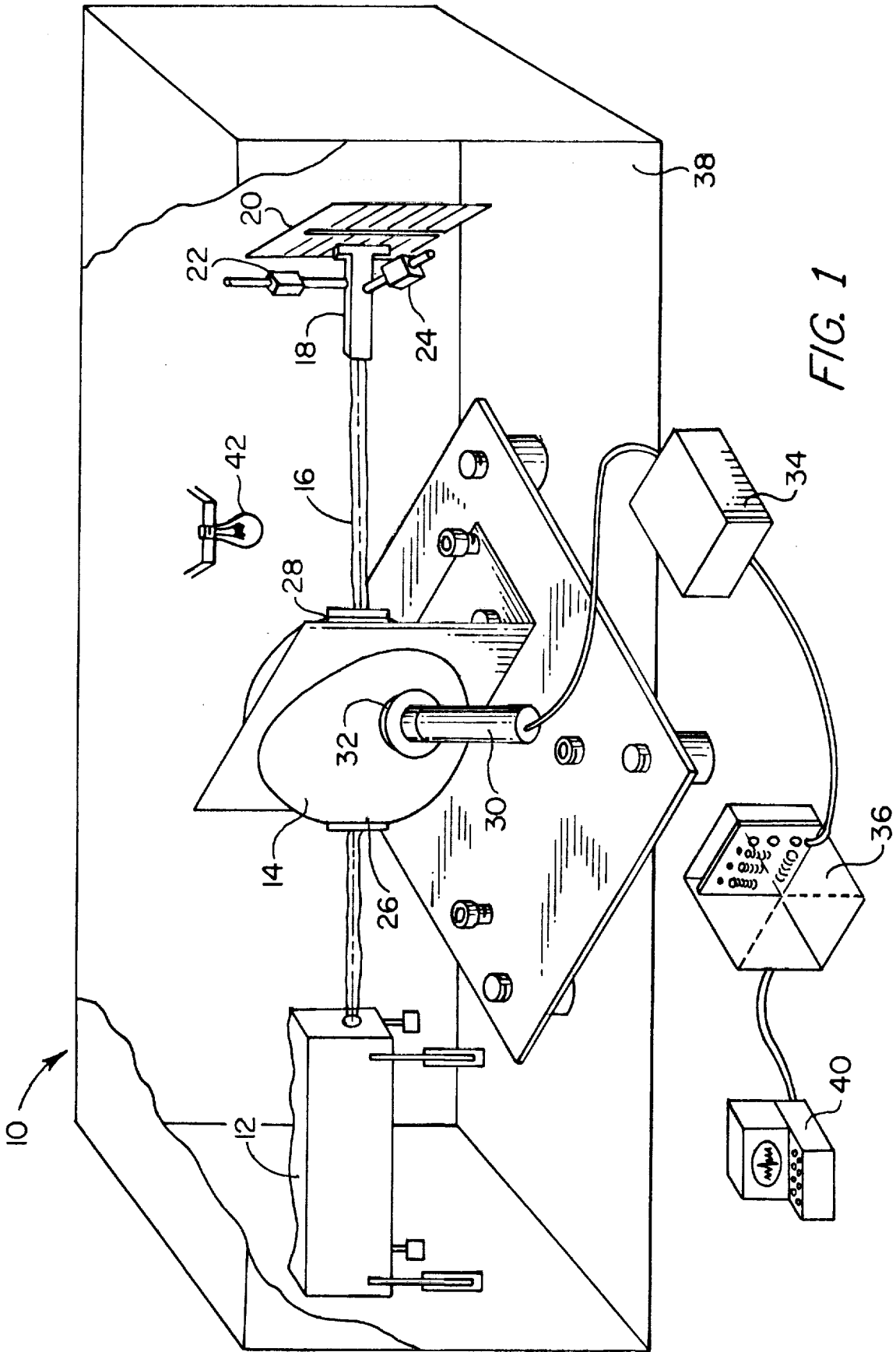

FIG. 1

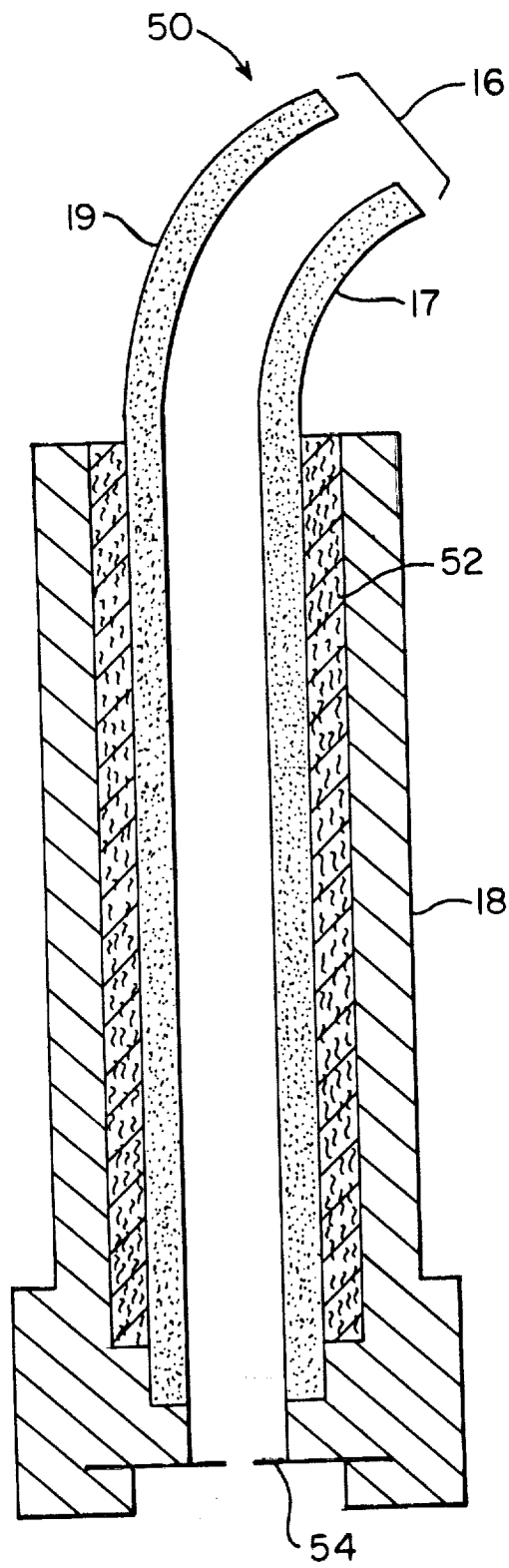

FIG. 2