

(NASA-TM-4221) NASA INFORMATION SCIENCES  
AND HUMAN FACTORS PROGRAM Annual Report,  
1990 (NASA) 225 p

NP1-27118

CSCL 05H

Unclass

H1/99 0025994

[The page contains extremely faint, illegible text, likely bleed-through from the reverse side of the document. The text is organized into several columns and paragraphs, but the characters are too light to be transcribed accurately.]

NASA Technical Memorandum 4291

NASA Information Sciences  
and Human Factors Program

*Annual Report, 1990*

Lee Holcomb, Ray Hood, Melvin Montemerlo,  
James Jenkins, Paul Smith, John DiBattista,  
Ramon De Paula, Paul Hunter, and David Lavery  
*NASA Office of Aeronautics, Exploration and Technology  
Washington, D.C.*



National Aeronautics and  
Space Administration

Office of Management

Scientific and Technical  
Information Program

1991



## **Introduction**

The Information Sciences and Human Factors (IS&HF) Division is one of five divisions that comprise NASA's Office of Aeronautics and Exploration Technology (OAET). This division sponsors research in both aeronautical and space technology, and Annual Report documents the most significant accomplishments during the past year. Each year, the Annual Report is prepared to serve as the primary mechanism for coordinating NASA activities with industry and industrial IR&D managers. This document also is intended to communicate significant technical accomplishments to NASA technologists, project engineers, other government agencies, and academia.

The IS&HF Program consists of seven major elements: Automation and Robotics, Computer Sciences, Communications, Controls and Guidance, Data Systems, Human Factors, and Sensor Technology. Accomplishments are presented in all seven categories with Controls and Guidance and Human Factors research represented in two sections, Space and Aeronautics.

The NASA Pathfinder Program was initiated in FY 1988 with the goal of providing a strong technology foundation for the nation's future space missions. The IS&HF Division has focused Pathfinder technology activities in Planetary Rover Technology, Human Factors/EVA suit, Automated Rendezvous and Docking, and Adaptive Hazard Avoidance Landing. In FY 1991, it is anticipated that more focused activities in Space Exploration technologies will be initiated.

Within the Base Aeronautics Human Factors Program, focused efforts in Aviation Safety/Automation were initiated in fiscal year 1989. The objectives of this program include the development of human-centered automation concepts for use in future transport aircraft and air traffic control (ATC) stations. The integration of highly automated aircraft into the future ATC system also will be addressed in this program augmentation. Beginning in FY 1990, the Airborne Wind Shear Detection and Avoidance research efforts were augmented to allow flight evaluation of Doppler radar, lidar, and infrared sensors.

To aid in communicating program efforts, the names and phone numbers of Headquarters program managers are included in this report along with the names and phone numbers of the key center technologists who conducted or managed the significant activities.

Division Director: Lee Holcomb  
(202) 453-2747

Deputy Director: Ray Hood  
(202) 453-2745

## NASA Directory

Center	Symbol
Ames Research Center Moffett Field, CA 94035	ARC
Ames Research Center Hugh L. Dryden Flight Research Facility Edwards, CA 93523	DFRF
Goddard Space Flight Center Greenbelt, MD 20771	GSFC
Headquarters NASA/OAET/RC Washington, DC 20546	HQ
Jet Propulsion Laboratory Pasadena, CA 91109	JPL
Lyndon B. Johnson Space Center Houston, TX 77058	JSC
John F. Kennedy Space Center Kennedy Space Center, FL 32899	KSC
Langley Research Center Hampton, VA 23665	LaRC
Lewis Research Center Cleveland, OH 44125	LeRC
George C. Marshall Space Flight Center Marshall Space Flight Center, AL 35812	MSFC

# Contents

<b>Introduction</b> .....	<b>iii</b>
<b>NASA Directory</b> .....	<b>iv</b>
<b>Automation and Robotics</b> .....	<b>1</b>
AutoClass III: An Automatic Classification System .....	2
Constraint-Based Scheduling .....	4
PI-in-a-Box, An Expert System for On-Board Experimentation .....	6
Telerobotics—Control and Execution .....	8
Large Knowledge-Based Systems Technology .....	10
Ground Data System Automation .....	12
High-Fidelity Computer Graphics Phantom Robot .....	14
Planetary Rover .....	16
Remote Manipulator System-Force Torque Sensor (RMS-FTS) .....	18
Traded and Shared Control .....	20
Remote Umbilical Development Program .....	22
Automated Assembly of Large Space Structures .....	24
LTM—A Dual-Arm Redundant Telerobotic System .....	26
Telerobotic Task Performance Evaluation .....	28
<b>Communications</b> .....	<b>31</b>
Optoelectronics Technology for Space Communications .....	32
SCOPE (Small Communications Optical Package Experiment) Breadboard .....	34
Space Laser Communication Technology .....	36
Configuration Definition Study of Large Deployable Geostationary Antenna Concepts .....	38
Large-Scale Antenna Surface Optimization Tests .....	40
60 GHz Traveling Wave Tube .....	42
Barium Dispenser Scandate Cathodes .....	44
High-Efficiency Traveling Wave Tube Amplifiers for Deep Space Communications .....	46
High-Efficiency UHF-TV Klystron .....	48
Scandate Oxide-Coated Cathodes .....	50
Submillimeter Wavelength Backward-Wave Oscillator .....	52
Theoretical Studies of Cathode Surfaces .....	54

<b>Computer Sciences</b> .....	<b>57</b>
Empirical Investigation of Sparse Distributed Memory Using Discrete Speech Recognition .....	58
Formal Verification of a Fault-Tolerant Clock Synchronization Algorithm .....	60
Mapping Unstructured Grids to Hypercubes .....	62
Performance Characterization of Machine Architecture .....	64
Performance Evaluation of an Implicit CFD Algorithm on a MIMD Hypercube .....	66
Two-Dimensional Shape Recognition Using SDM .....	68
Software Management Environment .....	70
Autonomous Exploration .....	72
Application and Assessment of Industry-Standard Guidelines for the Validation of Avionics Software .....	74
Automatic Generation of ADA Code .....	76
 <b>Controls and Guidance - Aeronautics</b> .....	 <b>79</b>
Ames/Langley Joint Simulation: 4D Aircraft/ATC Operations Study .....	80
Computer Aiding for Low Altitude Helicopter Flight Project .....	82
Field-Based Passive Ranging Using Matched Velocity Filter .....	84
Final Approach Spacing Tool .....	86
Terminal Area Operations with NAVSTAR Global Positioning System .....	88
Validation of Vision-Based Obstacle Detection Algorithms Using Flight Data .....	90
Automated Flight Test Management System (ATMS) Flight Test Engineers Workstation .....	92
X-29 High Angle-of-Attack Controls Technology .....	94
Demonstrated Incompatibility of Airborne and ATC-Generated 4D Descent Profiles .....	96
Evaluation of Candidate Wind Shear Detection and Clutter Suppression Algorithm .....	98
Flutter Suppression On An Active Flexible Wing .....	100
High-Temperature Fiber Optic Microphone .....	102
Laser Induced Fluorescence Diagnostics .....	104
Validation of Methods for Predicting Hypersonic Flight Control Forces and Moments .....	106
 <b>Controls and Guidance - Space</b> .....	 <b>109</b>
Adaptive Control Subsystem Development .....	110
Advanced Image Processors .....	112
Autonomous Star and Feature Tracking .....	114
Fiber Optic Rotation Sensor (FORS) .....	116



SHAPES (Spatial, High Accuracy, Position Encoding Sensor) .....	118
Coherent Launchsite Atmospheric Wind Sounder (CLAWS) Feasibility/Benefit Study .....	120
Closed-Loop Control Test on Mini-Mast .....	122
Personnel Launch System Approach and Landing Simulation Study .....	124
Advanced Control Evaluation for Structures (ACES) and Computational Control .....	126
Autonomous Rendezvous and Docking .....	128
<b>Data Systems .....</b>	<b>131</b>
Algorithms/Applications– FY90 Configurable High-Rate Processor System (CHRPS) .....	132
Automatic Image Data Encoding and Analysis .....	134
Configurable High-Rate Processor System (CHRPS) .....	136
Gallium Arsenide (GaAs) Pipeline Processor .....	138
SIMD CHIP– FY90 Configurable High Rate Processor System (CHRPS) .....	140
Source Encoding (Lossless Data Compression) .....	142
Data Storage Technology .....	144
Imaging Spectrometer Flight Processor–Lossless Data Compressor .....	146
MAX: Flight Multicomputer .....	148
Evaluation of ATAMM Performance on VHSIC Multiprocessor .....	150
SODR Controller Development .....	152
Spaceflight Optical Disk Recorder (SODR) .....	154
<b>Human Factors - Aeronautics .....</b>	<b>157</b>
Automated Recovery Recommendation System (RECORDS) Concept Designed, Implemented, and Evaluated for Aircraft Application .....	158
Brain-Wave Measures of Workload Show Promise for Transitioning From Laboratory To Flight Deck Simulator Environment .....	160
Flight Testing Validated Knowledge-Based Systems Concept for Primary Flight Display Information Management .....	162
Head Movement Correction Algorithm Eliminates False Translational Cues from Stereo 3-D Flight Display .....	164
Heads-Down Stereoscopic Flight Displays .....	166
Improved Prototype Decision-Aiding Concept and Pilot-Vehicle Interface (PVI) for In-Flight Diversions .....	168
Information Fusion to Improve the Detection of Wind Shear Threats .....	170
Performance Effects of Alternate Pathways and Stereo 3-D Presentation Determined in a Pictorial Display for Transport Landing Approach .....	172
<b>Human Factors - Space .....</b>	<b>175</b>
Advanced Extravehicular Activity (EVA) Suit Technology .....	176

Computer Graphic Representation of Visual Space .....	178
Dynamic Anthropometric Modeling.....	180
Virtual Interactive Environment Workstation .....	182
Symbolic Operator Model .....	184
Visualization for Planetary Exploration .....	186
Virtual Workstation for Planetary Exploration .....	188
EVA Aids .....	190
Human-Computer Interaction .....	192
Interface Design for User Control of Intelligent Systems .....	194
Strength and Motion Measurement.....	196
Strength and Motion Modeling .....	198
<b>Sensor Systems .....</b>	<b>201</b>
Improved Low-Temperature Readouts for Astronomical IR	
Detector Arrays.....	202
Space Qualified <sup>3</sup> He Cooler .....	204
Advanced Cryogenic Refrigerator for Space .....	206
Advanced Lidar Technology .....	208
Superconducting Magnetic Bearings .....	210
Diode-Pumped Neodymium Lasers .....	212
HgZnTe Materials and Device Technology.....	214
High-Temperature Superconductivity Material Applied to	
Devices for Aerospace Technology .....	216
Modeling of Multiply Doped Eye-Safe Solid-State Lasers for	
DIAL and Doppler Lidar .....	218
Titanium: Sapphire Development for Lidar .....	220

# Figures

<b>Automation and Robotics</b> .....	<b>1</b>
AutoClass III - Automatic Classification .....	3
Constraint-Based Scheduling .....	5
PI-in a Box .....	7
Real-Time Control of Intelligent Robotic Systems .....	9
Distributed Knowledge Base Management System .....	11
SHARP-Voyager .....	13
High-Fidelity Computer Graphics Phantom Robot .....	15
Planetary Rover .....	17
Remote Manipulator System-Force Torque Sensor .....	19
Traded Control .....	21
Shared Control .....	21
Remote Umbilical System and Seed Planting Robot .....	23
Automated Structural Assembly Laboratory .....	25
Dual-Arm Redundant Telerobotic System .....	27
Robotic Calibrated Task Board .....	29
<b>Communications</b> .....	<b>31</b>
Optoelectronics for Laser Communications at GSFC .....	33
SCOPE (Small Communications Optical Package Experiment)	
Breadboard .....	35
Space Laser Communication Technology .....	37
Large Deployable Antenna (LDA) Configuration Definition Guidelines .....	39
Deployable Truss Reflector Concept (Pactruss Design) .....	39
CSEI Surface Smoothness Tests .....	41
60 GHz TWT for Intersatellite Links .....	43
Thin Film Scandate Cathode .....	45
High-Efficiency TWT Technology For Deep Space .....	47
UHF Television Klystron with MDC .....	49
Scandate Oxide-Coated Cathodes .....	51
Submillimeter Backward-Wave Oscillator .....	53
Theoretical Studies of Cathode Surfaces .....	55
<b>Computer Sciences</b> .....	<b>57</b>
Discrete Speech Recognition Frequency Distribution .....	59
Formally Verified Fault-Tolerant Clock Synchronization .....	61
Map Irregular Problem to Regular Interconnection Topology .....	63
Performance Characterization of Machines .....	65
Comparison of ARC2D Performance .....	67
The Cortex Transform .....	69

Management of Complex Software Projects .....	71
Autonomous Exploration .....	73
Production of Realistic Software Error Data .....	75
ALS Case System .....	77
<b>Controls and Guidance - Aeronautics .....</b>	<b>79</b>
Air Traffic Simulation .....	81
Computer-Aided Low Altitude Helicopter Flight.....	83
Field-Based Passive Ranging Using Matched Velocity Filters .....	85
Simulator Evaluation of the Final Approach Spacing Tool .....	87
Terminal Approach Operations for GPS .....	89
Validation of Vision-Based Obstacle Detection	
Algorithms Using Flight Data .....	91
Automated Flight Test Management System .....	93
X-29 High Angle-of-Attack Controls .....	95
4D Trajectory Generation Techniques.....	97
Separation Conflict Induced by Incompatible Speed Schedules .....	97
Evaluation of Candidate Wind Shear Detection and	
Clutter Suppression Algorithm.....	99
Flutter Suppression for Active Flexible Wing.....	101
High-Temperature Fiber Optic Microphone .....	103
Laser Induced Fluorescence Diagnostics.....	105
Prediction of Forces and Movements for Flight	
Vehicle Control Effectors.....	107
<b>Controls and Guidance - Space .....</b>	<b>109</b>
High Performance Adaptive Control .....	111
Advanced Image Processor .....	113
Autonomous Star and Feature Tracking.....	115
Fiber Optic Rotation Sensor (FORS) .....	117
SHAPES: Spatial, High-Accuracy Position Encoding Sensor .....	119
On-Board Lidar Wind Sensor Range .....	121
First Active Control Test on Mini-Mast .....	123
PLS Approach and Landing Simulation Study .....	125
Advanced Control Evaluation for Structures (ACES) - II .....	127
Charged-Couple Device (CCD) Based Sensor .....	129
<b>Data Systems .....</b>	<b>131</b>
Lossless Data Compression .....	133
Comprehensive Vision System.....	135
CHRPS Architecture.....	137
GaAs Pipeline Processor .....	139

SIMD Chip .....	141
Source Encoding .....	143
Data Storage for Spacecraft .....	145
CHIP Functional Block Diagram .....	147
HIRIS Command and Data Subsystem .....	147
MAX Architecture .....	149
VHSIC Multiprocessor Flight Brassboard .....	151
SODR Controller Development .....	153
SODR Program Accomplishments .....	155
<b>Human Factors - Aeronautics .....</b>	<b>157</b>
Recovery Recommendations for Fault Management .....	159
Evoked Potential Monitoring Task .....	161
Workload Effects on Evoked Potential (EP) Peaks .....	161
PFD Information Management .....	163
Stereo 3-D Displays .....	165
Parallax Effect With and Without Correction Normalized to Screen Distance .....	165
Stereoacuity Experiment Results .....	167
DIVERTER–Decision Aiding for Diversions .....	169
Use of Information Fusion to Improve the Detection of Wind Shear Threats .....	171
Pilots' Visual Range-Tracking Task and Alternate Pathway Formats .....	173
Effect of Pathway Format on Simulated Landing Approaches .....	173
<b>Human Factors - Space .....</b>	<b>175</b>
Demonstration of EVA Suit Technology .....	177
Computer Graphic Representation of Visual Space .....	179
Dynamic Anthropometric Modeling .....	181
Virtual Interface Environments .....	183
Scheduler for MIDAS' Operator Model .....	185
2-D and 3-D Topographic Presentation of Viking Data .....	187
Virtual Workstation for Planetary Terrain Visualization .....	189
EVA Performance Aids .....	191
Human-Computer Interaction .....	193
Design for User Control of Intelligent Systems .....	195
Launch/Entry Suit Reach Measurement .....	197
Biomechanical Modeling .....	199
<b>Sensor Systems .....</b>	<b>201</b>
Improved Low-Temperature Readout Electronics for IR Detector Arrays .....	203
Sub-Kelvin Cooler Technology <sup>3</sup> He Cooler .....	205

Cryogenic Refrigerator for Space .....	207
OAET/GSFC Advanced Lidar Technology .....	209
Superconducting Magnetic Bearings .....	211
Diode-Pumped Neodymium Technology .....	213
HgZnTe Solves NASA Requirements for Reliable Longwave IR Detectors .....	215
High-Temperature Superconductivity Materials Applied to Devices for Aerospace Technology .....	217
Model Development For 2-Micrometer Eye-Safe Lidar .....	219
Titanium: Sapphire Laser Products .....	221

## **Automation and Robotics**

OAST created the Civil Space Technology Initiative (CSTI) to improve NASA space technology. Of particular concern has been the cost of NASA ground and flight operations, such that the CSTI program has focused significant resources on development and demonstration of automation and robotics technologies for space applications. Artificial intelligence and telerobotics, when applied to the space environment, have the capability to improve productivity and enhance safety significantly, as well as reduce the cost of NASA operations.

The Automation and Robotics Program is divided into two areas, with the Telerobotics Program focusing on automation for in-space servicing, assembly, and repair. Applications demonstrations are planned at NASA mission centers for the transfer of the technology into the operations environment. Underlying the demonstrations are five research areas that will develop expertise in robotics, supervisory control, advanced teleoperation, and launch processing systems. Coordination with DARPA's Automation and Robotics Program is achieved since NASA acts as a DARPA agent.

The Telerobotics Program has achieved major technology demonstrations through three significant activities: the automated assembly of a planar truss space structure, human/telerobot cooperative operations during repair of the Hubble Space Telescope in a neutral-bouyancy simulation, and completion of components of the Solar Max Repair mission using advanced teleoperations instead of astronaut EVA activities. The Artificial Intelligence Program has developed an operational readiness prototype expert system for monitoring the Shuttle communications systems and initial integration of the EXODUS system for diagnostics and control of the Shuttle Environmental Control System. Also, we developed an expert system for aiding in the evaluation of the communications systems for unmanned planetary spacecraft, which was first operationally used during the Voyager encounter with Neptune.

Major research goals were accomplished in the areas of telerobotics operator interface and data analysis techniques. In the operator interface element, higher-performance force reflecting hand controllers and triggers were tested for teleoperation. In the AI data analysis techniques element, a collaborative effort with DARPA began on research of intelligent communicating agents, while the Autoclass probabilistic reasoning system produced striking new classes of spectral objects when applied to Infrared Astronomical Satellite data.

In addition to the CSTI technologies, OAET has been reviewing the technology requirements for future planetary and lunar missions and has packaged these into the initiative called the Exploration Technology Program. In the area of exploration, a significant amount of automation and robotics research will be focused on the development of a planetary rover that would act in the place of humans in the scientific discovery efforts of the Moon and Mars, semi-autonomously, with only occasional communication and direction from Earth. This is a challenging problem in that the rover will effectively be a mobile laboratory with its own instrumentation, tools, and intelligence for self-navigation and rock sample acquisition and analysis. This development effort is a requirement unique to NASA and builds on the in-house expertise in automation and robotics that has resulted from the CSTI program.

Program Manager: Melvin Montemerlo  
NASA/OAET/RC  
Washington, DC 20546  
(202) 253-2744

## AutoClass III: An Automatic Classification System

---

AutoClass is an automatic classification program that will accept a data base of cases and find classes (if any) that best describe the cases. The approach used in AutoClass is based on Bayesian statistics and it determines how many classes and the class descriptions automatically. Previous methods, such as clustering, require the user to provide a "similarity measure" between cases and an indication of how many classes are present. AutoClass can handle a mixture of real and discrete value attributes and also missing data. It has already demonstrated its utility in analyzing many data bases, large and small.

NASA has many large data bases that are largely unanalyzed. AutoClass is a tool for preliminary data analysis that can give the user a different view of the data by showing the classes of objects in the data base. The insight generated by such classifications can be the basis for further investigation.

AutoClass was recently released for public use through Research Institute for Advanced Computer Science. This is a rewritten version of the original experimental software; it is much easier to use, relatively bug free, runs on many different systems, and has extensive documentation. We estimate that 30 sites have currently received the software. It has been used in house to analyze many data bases, including the recent new IRAS spectra classification (NASA ref. publ. #1217), and has discovered new classes of clouds (joint research with CalSpace). The current version of AutoClass is being extended to include hierarchical classification and to allow correlations between variables within a class.

### Technical Contact

Peter Cheeseman, ARC, (415) 604-4946



# AutoClass III — Automatic Classification

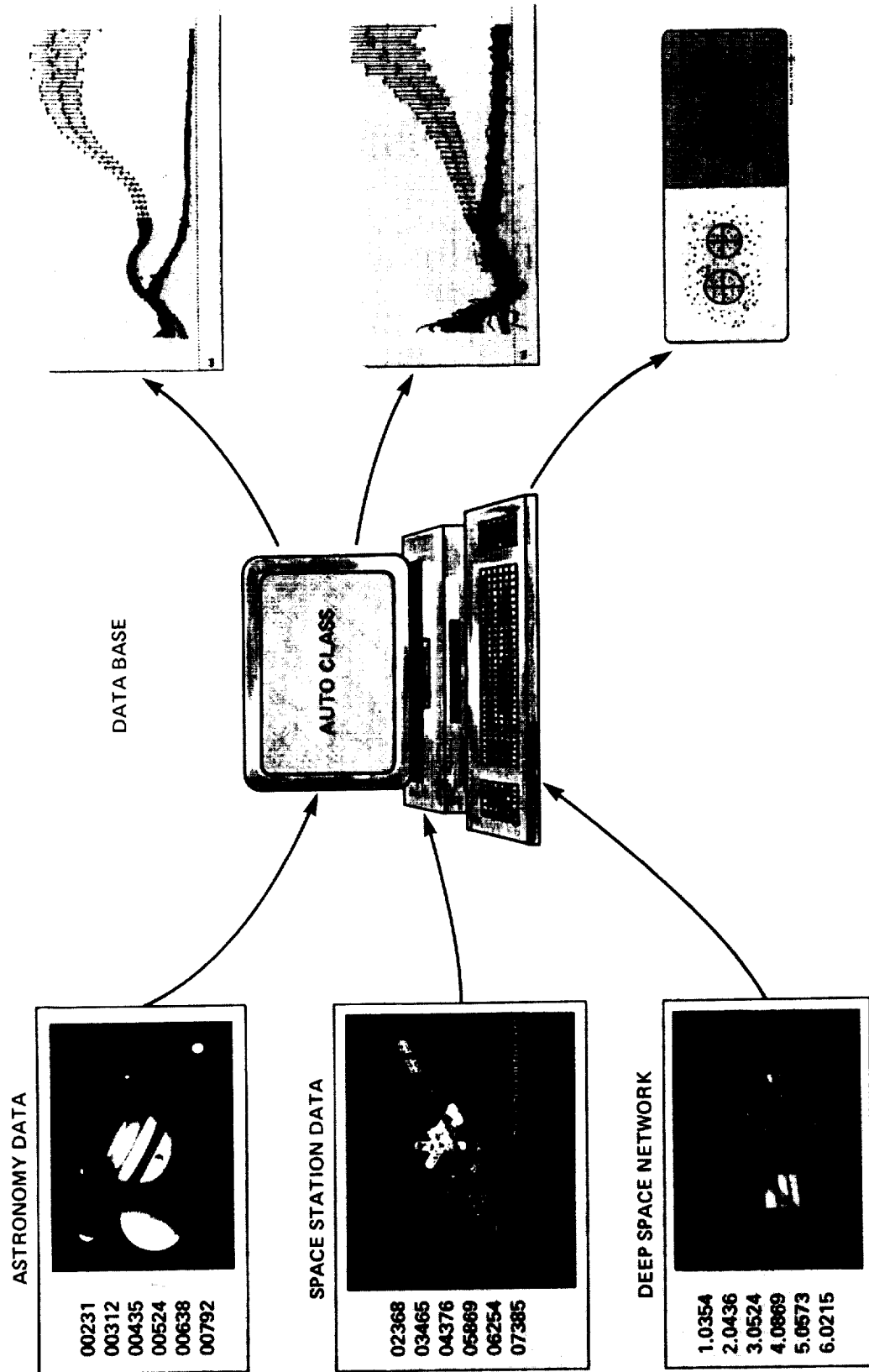

ORIGINAL PAGE IS  
OF POOR QUALITY

## Constraint-Based Scheduling

Constraint-based scheduling entails the application of heuristic search techniques to solve complex, real-world, scheduling problems. This project involves fundamental research in the development of heuristics and search algorithms to address such problems, tool development for encoding these heuristics and algorithms, and the production of an end application to Space Shuttle Orbiter Processing at the Kennedy Space Center (KSC).

Most off-the-shelf scheduling tools, such as those used at KSC, are deficient in that they have limited constraint languages, they sometimes fail to find an acceptable schedule even though one exists, they have non-interactive interfaces, they ignore optimization issues, and finally, they do not have the ability to reactively reschedule without performing a complete re-analysis.

In 1990, our efforts concentrated on four major foci: (1) the development of a generic scheduling and rescheduling tool, (2) the study of repair-based search algorithms for scheduling, (3) the application of machine learning to scheduling, and 4) the application and deployment of the scheduling tool at KSC for Space Shuttle processing. This application is a team effort supported by NASA Ames, Lockheed Artificial Intelligence Center, and the Lockheed Space Operations Corporation. In FY 1991, we plan to deliver an interactive scheduling tool that is effectively integrated into the KSC Shuttle Processing Data Management System (SPDMS-II).

The goal of our efforts in both repair-based search algorithms and machine learning is the quick production of better quality schedules. A repair-based scheduling algorithm is given a rough schedule and then uses heuristics to iteratively improve the weakest portions of the sched-

ule. We have demonstrated that these techniques offer significant improvements over traditional search methods in two NASA domains: KSC Space Shuttle scheduling and Hubble Space Telescope science scheduling. In our machine learning experiments, we have also demonstrated that it is indeed possible for a scheduling system to learn to predict scheduling bottlenecks and thus improve its own performance.

### Technical Contact

Monte Zweben, ARC, (415) 604-4940  
Steve Minton, ARC, (415) 604-6522

## Constraint-Based Scheduling

- Expected to reduce ground operations time and cost per launch by streamlining and optimizing operations.
- Supports dynamic rescheduling in response to resource conflicts, operational problems, and other unexpected conditions.
- Provides operations personnel with an on-line "window" to schedules that are in-process, projected or completed.

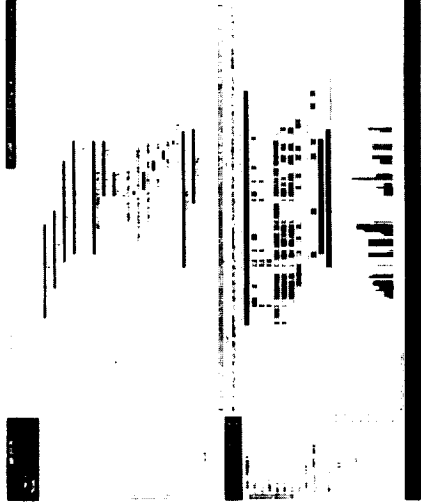

## PI-in-a-Box, An Expert System for On-Board Experimentation

Experimental science as conducted in existing spaceborne laboratories, such as Spacelab or future ones such as Space Station *Freedom*, is severely constrained in several respects: the PI is normally not on the spacecraft, and communication with the ground is limited in bandwidth and availability. Because the air-to-ground voice links are open, free discussion of experimental alternatives is inhibited. Furthermore, the experiment-specific decision-making ability of the crew is limited by the training they have received before the flight and by the time they have available in flight. The longer missions on board the Space Station make it more likely that contingencies will arise for which the crew will have had no adequate preparation. Crew members have voiced a strong desire to have available on board enough information about complex experiments to enable them to be productive, reactive scientists.

The purpose of the PI-in-a-Box project is to develop an intelligent assistant for the astronaut experimenter that contains much of the knowledge domain of the PI. The primary user of the system will be the astronaut performing an experiment, but use of the system by the PI and possibly by the Mission Manager is also envisioned. The initial emphasis is on real-time consultation between the astronaut and the program, and between the PI and the program, during all three phases of experimentation: before, during, and immediately after the flight. The program serves the following functions: signal quality monitoring, malfunction diagnosis, experiment protocol management, quick-look data analysis, determination of possible events of unusual significance, suggested protocol changes, and anticipation of needs for additional resources.

This system will increase the productivity of astronauts performing scientific experiments by enabling them to

have immediate access to the kind of information that normally can be obtained only by communication with the PI on the ground. The architecture of the system incorporates AI technology for diagnosis and troubleshooting, scheduling, protocol management, and for alerting the crew to unusual and potentially important phenomena. These functions are of general importance to space operations, and this system will provide a testbed for new ideas and for facilitating technology transfer.

The initial development of PI-in-a-Box is being carried out in the context of an experiment in vestibular physiology that was devised by Professor Laurence Young of MIT. We have built prototypes for a Protocol Manager, an Interesting Data Filter, a Diagnosis and Troubleshooting Module, a Data Acquisition and Data Quality Monitor, and a user interface. All the modules are integrated on two Macintosh computers for a series of tests to be run in the Baseline Data Collection Facility at JSC in preparation for ground support of a mission (SLS-1) scheduled for later this year. The first test (150 days before launch) was performed in March 1990 and demonstrated the ability of the system to work as a unit and to keep up with real-time data from the ground version of Young's experiment.

Technical Contact  
Silvano Colombano, ARC, (415) 604-4380

# PI-in a box

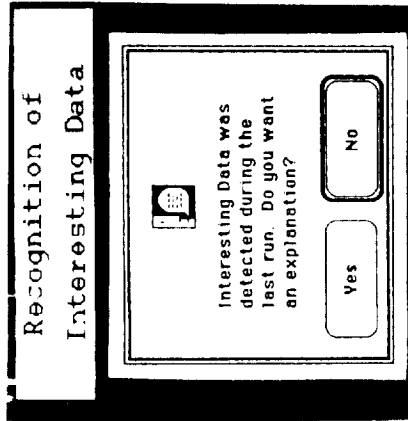
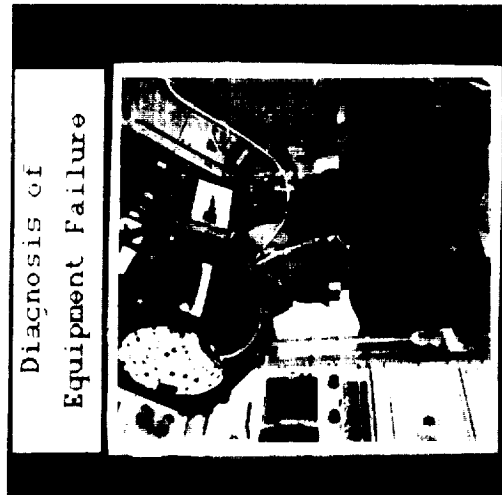

# PI-in-a-box

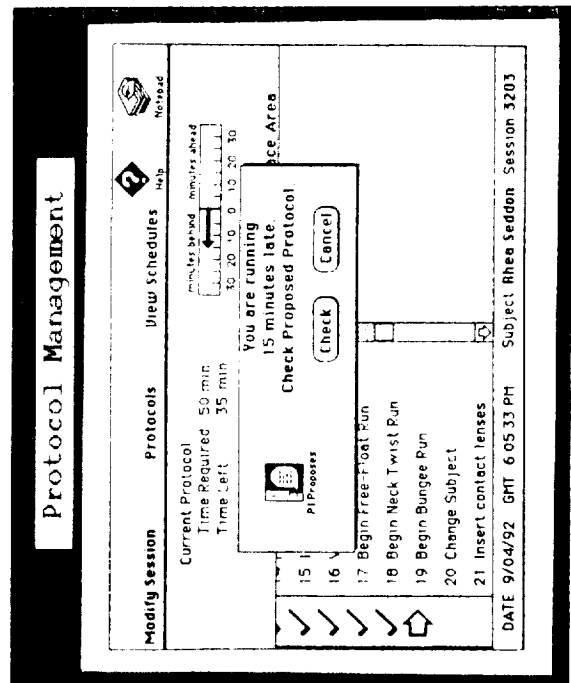
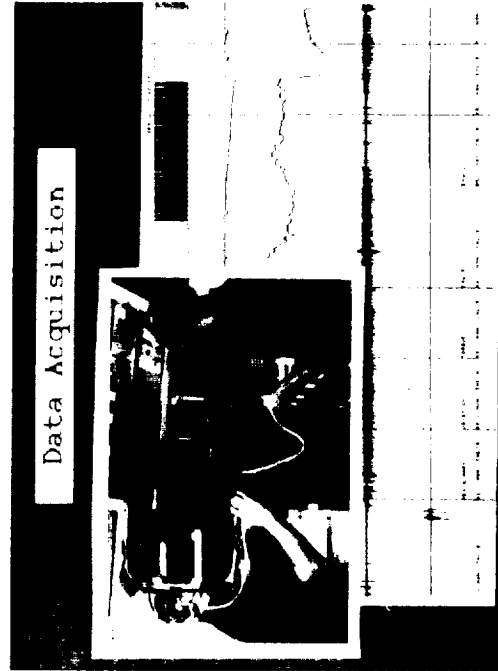

ORIGINAL PAGE  
BLACK AND WHITE PHOTOGRAPH

## Telerobotics - Control and Execution

---

Through the development and use of intelligent robots, an astronaut or crew member will be able to concentrate effort on complex tasks rather than on the execution of repetitive, labor-intensive tasks. This research effort focuses on the real-time control and task planning for mobile, cooperating two-arm robots and on the development and implementation of object-level control and execution including operator interface. Systems architecture challenges include autonomous navigation and task level control of cooperating robots, real-time control of cooperating arms involving multiple robots, and object manipulation and task planning strategies.

Separate research elements in artificial intelligence and robotics are being pursued in other research programs. However, they are not focused on the development and system integration of technologies required for the real-time control and execution of intelligent robotic systems. As a result, the evolution and integration of these separate technologies may be too costly to implement in an operational environment.

In 1989, object-based control using dual cooperating manipulators was developed, implemented, and demonstrated on a mobile robot with two cooperating arms. Object-based manipulation capabilities restricted to a planar motion was demonstrated for operations tasks involving object retrieval, manipulation, and assembly. This capability served as the basic infrastructure for the development and control of two or more two-cooperating arm robots performing interactive construction, assembly, and servicing tasks.

The design of a complete three-dimensional cooperating arms mobile robot has been completed, and construction of

the mobile robot (an air cushion vehicle) is in progress. Object-based control using cooperating manipulators located on a flexible mounting base has been demonstrated. This capability allows the investigation and simulation of many of the dynamic effects that will be encountered using the force torque system (FTS) manipulator system in conjunction with the Attachment, Stabilization, and Positioning System (ASPS) or when attached to the end of a larger manipulator such as the Shuttle RMS.

The real-time control algorithms have been demonstrated to the Space Station *Freedom* FTS contractor, and the software code has been provided to them. The advances made in dynamics, control, system integration, high-level operator interfaces, and overall system architecture have also been briefed to the FTS design team.

Technical Contact

Henry Lum, ARC, (415) 604-6544

# Real-Time Control of Intelligent Robotic Systems

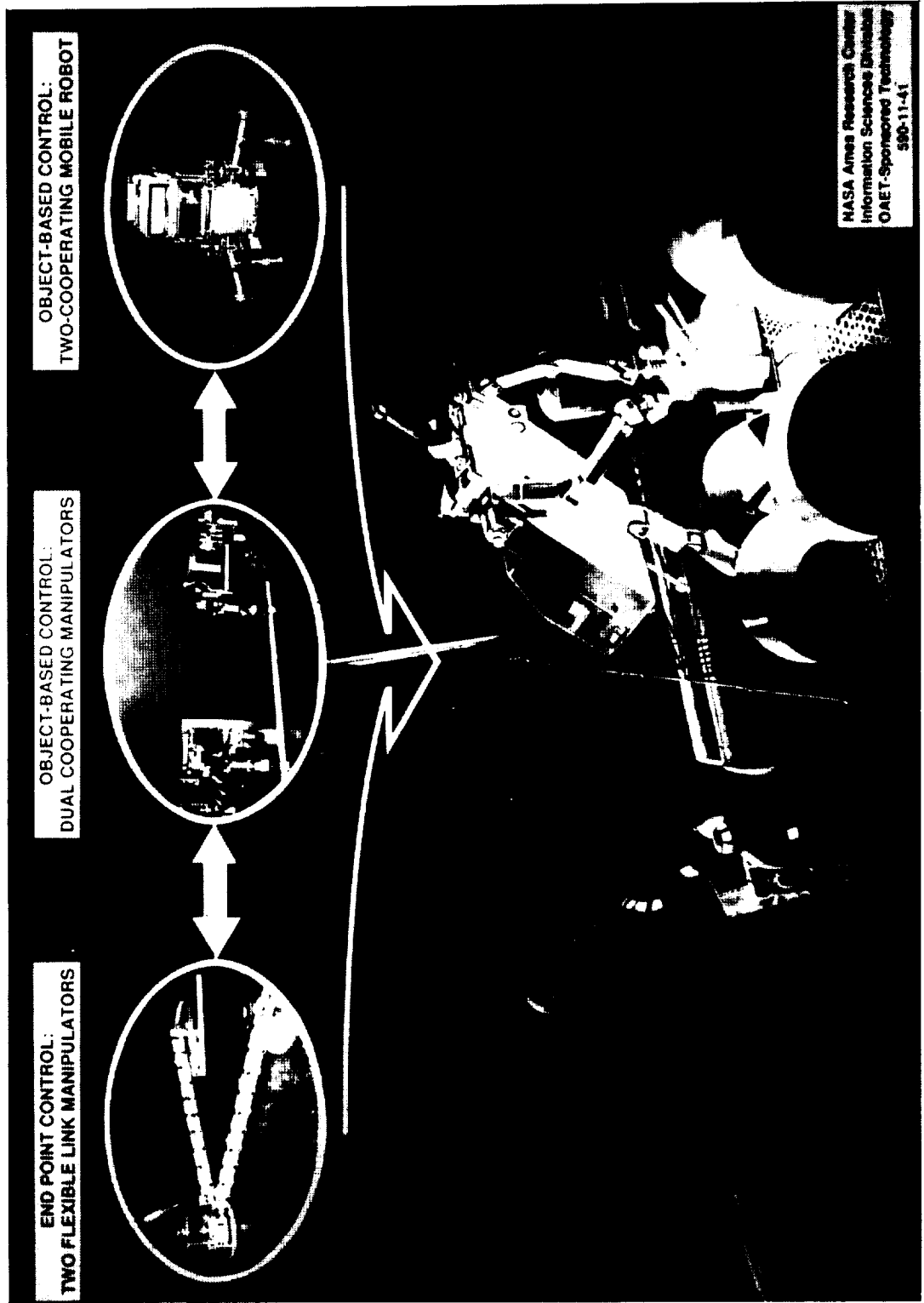

## Large Knowledge-Based Systems Technology

The increasing complexity of spacecraft platforms such as those for EOS will require advanced control center systems architectures to assist spacecraft operations in monitoring and analyzing hundreds of engineering parameters and in resolving anomalous situations. Expert or knowledge-based systems are now seeing limited use as spacecraft operators, however, these are still at the level of individual spacecraft functions. This task will develop the technologies needed for automated control center operations realized through the use of distributed cooperating knowledge-based systems, including expert systems. A major goal of this work will be to develop a methodology and framework to support the interconnection of discrete knowledge-based systems (e.g., expert systems monitoring individual spacecraft functions) to perform cooperative problem solving at the higher level of overall spacecraft operations. A prime operational goal of this task will be to devise a distributed knowledge-base testbed to be used to perform operational experiments involving distributed knowledge-based systems.

Current ground/space systems for spacecraft control depend on a highly synergistic mix of complex hardware/software systems and dedicated, highly trained operators functioning in a cooperative and collaborative manner to maintain effective and efficient operations. As these human/machine systems become more automated, in response and reaction to increasing operational complexity, more use will be made of knowledge-based system components. These will be configured and executed in a framework specifically designed to facilitate both coordination and cooperation in supporting operations, and high-level interfaces/interac-

tions with the system's human operators. This task helps provide the core technology development in knowledge-base management required to achieve this degree of automation.

A distributed testbed involving five machines on a network currently exists and has been demonstrated to the NASA AI Intercenter Working Group (AIIWG) and to various projects including EOS. Upgrades of the satellite simulator are currently under way and will include the use of a small robot. Upgrades to the user interface are also in progress and will concentrate on techniques for providing error and status messages. A concept paper on an Intelligent Control Center (ICC) is currently being developed. In a joint effort with Ames Research Center, we are also beginning to plan the application of these technologies to EOS.

Technical Contact

Robert Dominy, GSFC, (301) 286-4196



# Distributed Knowledge Base Management System

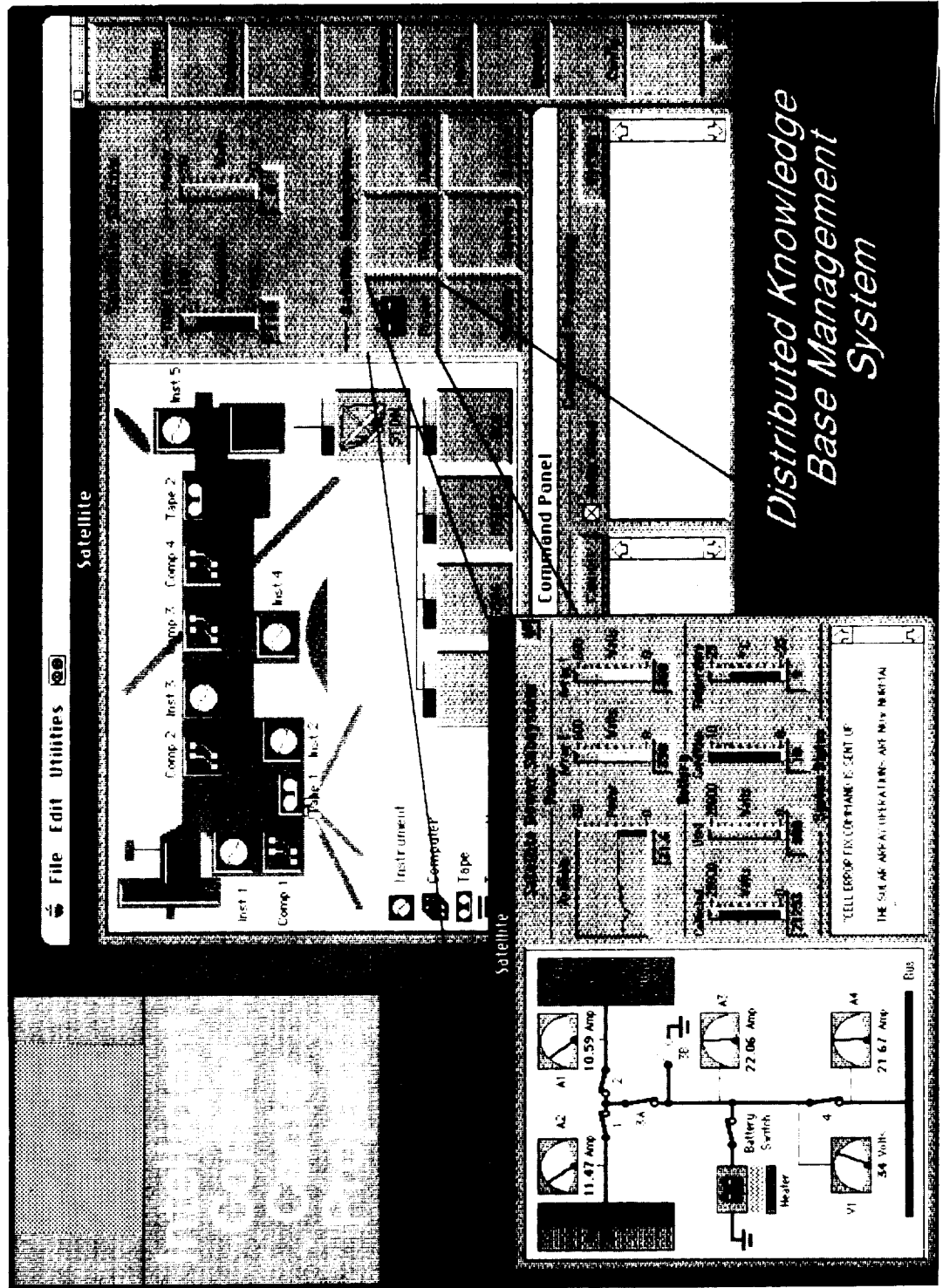

*Distributed Knowledge Base Management System*

ORIGINAL PAGE IS OF POOR QUALITY

## Ground Data System Automation

The objectives of this task are to develop and demonstrate applications of artificial intelligence to mission operations for unmanned planetary spacecraft and ground data systems, and to transfer the technology products to implementing organizations for use in developing operational systems.

The (Spacecraft Health Automated Reasoning Prototype) SHARP, a software system for monitoring the condition of interplanetary spacecraft and ground systems, was completed and evaluated in support of the Voyager II spacecraft's encounter with the planet Neptune. The system was used to monitor and analyze the health and status of the telecommunications link with the spacecraft during the encounter over a period of approximately 480 hours of operational testing. SHARP helped detect, find the cause of, and solve, a science data anomaly that appeared as a discrepancy in the relationship between Symbol Signal-to-Noise-Ratio and Bit Error Rate in the telemetry. The successful development of SHARP has shown the viability of artificial intelligence technology in a real-time operations application, and demonstrated specific performance parameters and design considerations for use in the development of operational systems. SHARP has shown that a knowledge system can detect and analyze important problems, which now take human operators minutes or hours, in a matter of seconds. The systemwide status monitoring afforded by SHARP helps operators assure correct system configuration and reduces commanding or configuration errors. The level of automation delivered by SHARP promises to reduce the real-time link analysis operations staff by a factor of five, with

similar savings possible in other subsystem areas.

SHARP's embedded diagnostic module was used to automatically detect anomalies and to make recommendations for corrective action. Other functions included analysis of predict residuals, antenna pointing performance, link status, and sequence of events execution. Dynamic graphical displays provided overviews of spacecraft and ground system status.

SHARP is currently being extended and ported to the SUN/4 Sparcstation for use and extended evaluation in Magellan telecommunications operations. The technology is being applied in the development of the Multimission Spacecraft Analysis System (MSAS) to automate routine monitoring and diagnosis functions for all JPL spacecraft, and is also being applied in the Deep Space Network (DSN) Network Operations Control Center (NOCC) upgrade where it will assist NOCC operators in monitoring the performance of the entire DSN telecommunications system. In FY 1991, a second prototype will be developed to assist DSN station Link Monitor and Control operators in controlling the station's systems during prepass calibration activities by automatically generating commands for operator enactment. The process of prepass calibration is currently labor intensive and subject to human error. An artificial intelligence approach could fully automate the process for big improvements in station performance.

Technical Contact:

David J. Atkinson, JPL, (818) 354-2555

# SHARP - Voyager

---



SCATTER PLOT FOR QUICK DIAGNOSTICS

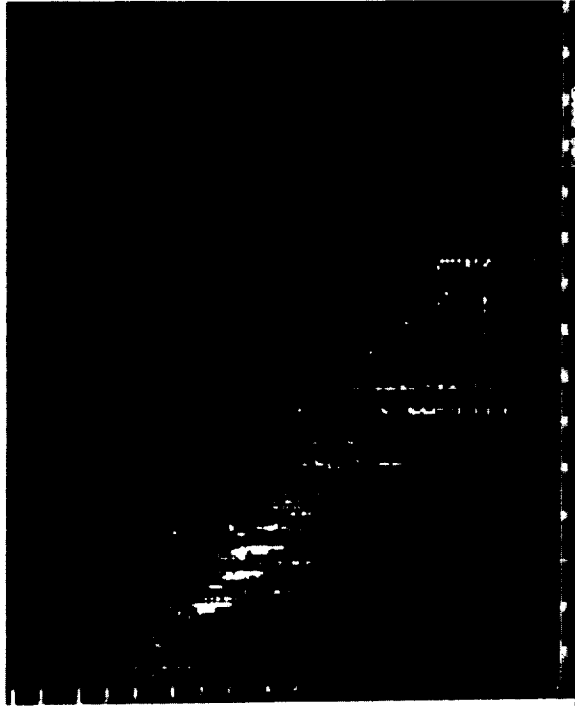

ERROR RATE vs. SIGNAL-TO-NOISE RATIO

## High-Fidelity Computer Graphics Phantom Robot

This task is focused at the use of the computer to create high-fidelity graphic images of telerobots (called "phantom robots") to help visualization of robot motion planning (called preview displays). The value of a computer graphics generated phantom robot depends on three factors: (1) high-fidelity graphics representation of the real robot and, if needed, high fidelity in the graphics representation of the work environment; (2) high-fidelity calibration of robot/environment graphic images to the TV images of the robot environment; and (3) high-fidelity interaction of the real robot controller with the phantom robot. This development work included all three factors.

The success of a telerobotic space operation relies partly on high-fidelity action planning and partly on control action verification capability before the action takes place. This capability requirement becomes even more significant when dual and/or redundant arm systems are operated in a constrained, realistic environment. High-fidelity preview displays will provide visually perceivable and realistic action planning/verification capability, thus reducing operation uncertainties and increasing operation safety.

The solid-shaded and wire-frame high-fidelity graphics representation has been extended to support a dual-arm system performing work on a multiwindow task board. This display has been augmented with real-time status display of robot arm joint variables. The motion of the robot system's graphics image is controlled from one or two 6-DOF force reflecting hand controllers in real time. Several tasks have been tested on this preview display (see

illustration) to outline the geometric conditions under which the dual-arm tasks become doable or undoable. This preview display also serves as an introductory training tool for operators. These displays also permit arbitrary perspective viewing of robot arms/work space relations unattainable from TV camera view. Calibration techniques have been developed to achieve a high-fidelity geometric overlay of robot arm graphic images over TV images (see illustration) for control experiments using predictive display.

### Technical Contact

A.K. Bejczy, JPL, (818) 354-4568

W.S. Kim, JPL, (818) 354-5047

S. Venema, JPL, (818) 354-1741

# High-Fidelity Computer Graphics Phantom Robot

- PREVIEW DISPLAYS HELP DUAL-ARM WORK PLANNING IN REAL TIME

CALIBRATED TASK SET-UP

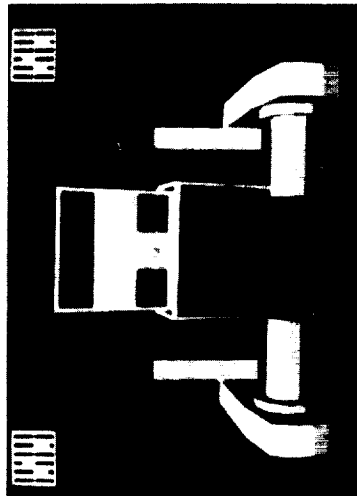

WORK UNDOABLE (ARMS COLLIDE)

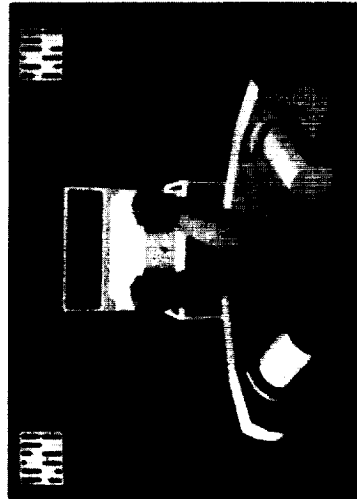

WORK DOABLE



- GRAPHICS CALIBRATION ENABLES ACCURATE MOTION PLANNING-AND-PREVIEW

CALIBRATION OF GRAPHICS  
IMAGE OF ROBOTS TO TV IMAGE  
OF REMOTE ROBOTS



OVERLAY OF CALIBRATED  
GRAPHICS IMAGES ON TV  
IMAGE OF REMOTE ROBOTS

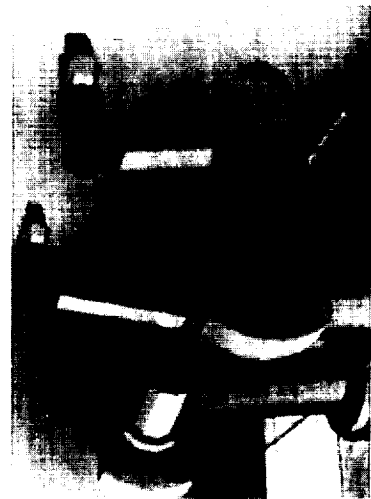

GRAPHICS IMAGES REAL-TIME  
MOTION ACCURATELY PREDICTS  
MOTION OF REMOTE ROBOTS



## Planetary Rover

The Planetary Rover (PR) program will develop, integrate, and validate the required technology to enable surface operations of the Space Exploration Initiative (SEI). Technology development efforts include sensing, perception, and control execution to enable autonomous navigation through rough natural terrain.

The PR program will provide technology for NASA SEI missions with planetary roverelements such as unmanned exploration and science, unmanned construction and mining, and piloted surface operations at a planetary outpost. The initial focus of the program has been the development of autonomous navigation technology for unmanned rovers. For unmanned missions, autonomous navigation significantly increases the traverse rate and, thus, the mission return under conditions of long communication delays. For manned missions, it offers the potential of freeing the astronauts for more creative tasks.

The construction of the rover navigation testbed, named "Robby," was completed in December 1989. Robby is a six-wheeled, three-body articulated vehicle. Compared to conventional four-wheel, single-body vehicles, it offers superior mobility. A commercial robot arm, to be used for future sample acquisition experiments, is mounted on the front body. The middle body contains an electronics rack to house the on-board processors and other electronics. It also serves as a mounting pedestal for the stereo camera navigation sensors. The rear body contains a commercial generator. Over 25,000 lines of new application software were developed and integrated on Robby to provide SAN

functionality. On May 7, 1990, the first continuous SAN traverse was achieved in the rough, natural terrain test course adjacent to the JPL facility. Continuous cycling, over the full test day, was accomplished and produced two complete SAN cycles and transition to a third cycle covering a range of 12 meters. Other accomplishments include:

- o development of mobility analysis tools which enhance the ability to design wheeled vehicles and enhance safety during path execution,
- o development of a novel fabrication technique for producing improved thermoelectric conversion materials and production of samples that showed a fourfold reduction in measured thermal conductivity, and
- o development of an unmanned science/exploration rover simulation tool that is being used to develop advanced mission operations technology.

Technical Contact

R. Bedard, JPL, (818) 354-4238

# Planetary Rover

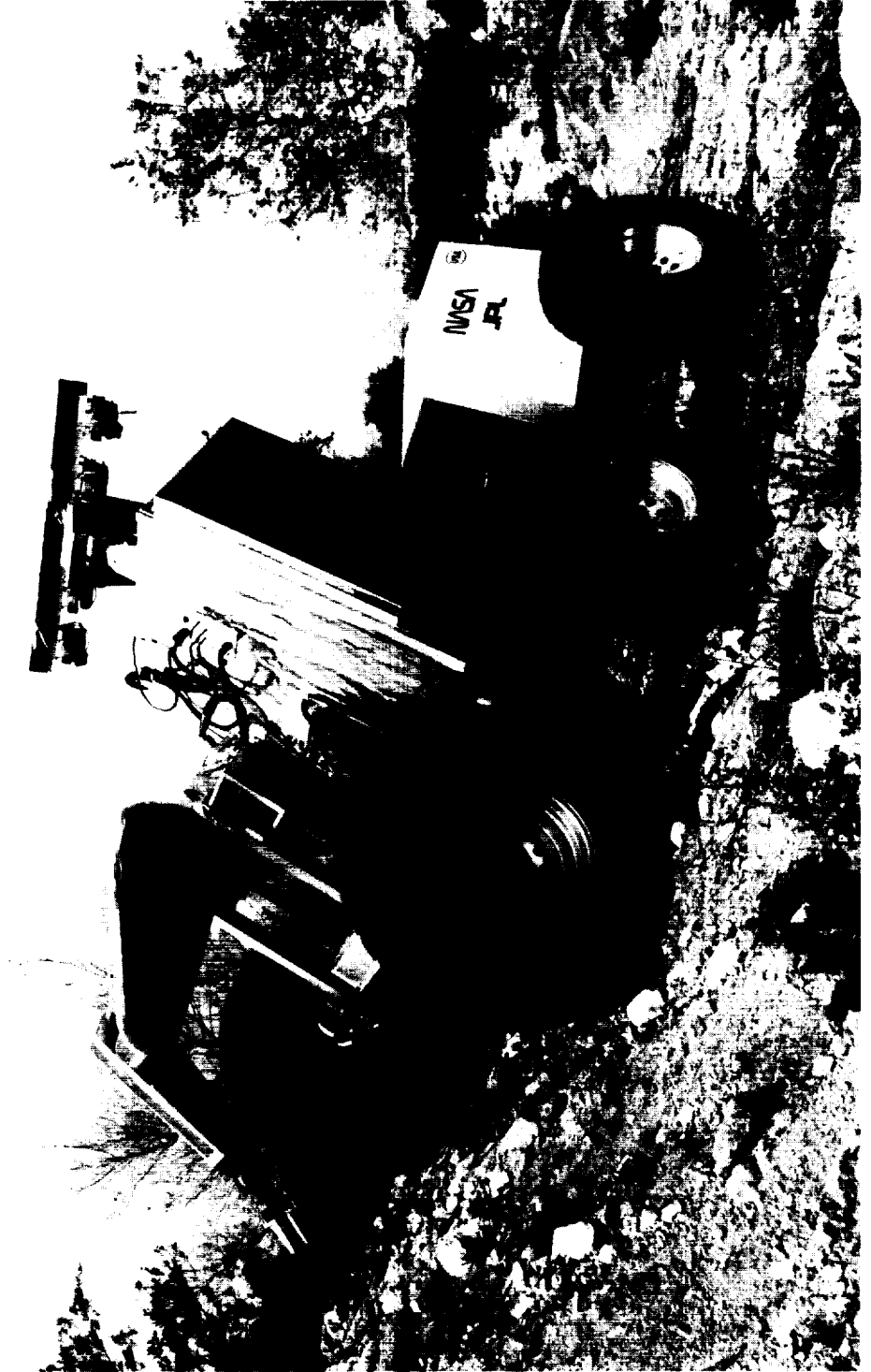

ORIGINAL PAGE  
BLACK AND WHITE PHOTOGRAPH

## Remote Manipulator System — Force Torque Sensor (RMS-FTS)

The force torque sensor (FTS) flight instrument serves as an enhancement to the Remote Manipulator System (RMS) by providing the detection of forces and torques acting upon the arm when in contact with other objects. Two major elements comprise the RMS-FTS system. A sensor element containing strain gauges and data acquisition electronics is attached to the RMS near the wrist joint. Information transmitted from the sensor element is received by an on-board computer element that translates the data into graphics and numerical video displays. These displays give the astronauts a highly accurate tool for observing imposed forces and torques acting on the arm in each of the six translational and rotational axes. The FTS system is currently targeted to be integrated into the Dexterous End Effector system at JSC for flight experiments in late 1992. With both sensitivity and resolution at a fraction of a pound, the RMS force torque sensor promises to be an essential tool for orbital servicing and assembly tasks.

The shuttle RMS has already proven itself to be critical to the success of several space missions, most notably the Solar Max satellite repair. Until now, the detection of forces acting upon the arm when in contact with other objects has not been available to the astronaut crew. Incorporation of the flight FTS onto the RMS, directly or as part of an end effector assembly, provides an operator with visual force feedback during manipulator operations involving constrained motion. This makes feasible operations requiring very small amounts of force (5 - 50 lbs). At times when comprehensive views of the worksite are not available, force torque sensing provides a sensor of "touch" to augment existing visual data in such operations as mating and demating connectors. Balancing end effector forces and torques can aid in positioning and alignment of the RMS arm in preparation for insertion and detachment

tasks. The magnitude and direction of excessive forces imposed by or on the RMS arm can be detected in real-time enabling immediate corrective action. Extensive range (configurable between 10 lbs. and 10,000 lbs. full scale) and high sensitivity (0.05% of full scale) give the RMS-FTS a wide applicability to both shuttle and space station based operations.

Deliverables to JSC include primary and backup flight units and a nonflight training unit for integration into the Manipulator Development Facility (MDF). Flight hardware and data interfaces to the Dexterous End Effector and shuttle systems have been established. The primary flight unit has been completed and is undergoing acceptance and environmental testing with expected shipment to JSC early in the fourth quarter of 1990. The training unit is destined for the last 2 years; the flight computer element for the backup unit has been successfully serving as the training unit in the MDF. With the delivery of the new training unit, the flight computer will be returned for recertification and integration with its accompanying flight sensor element. The backup unit will be tested and delivered to JSC by the end of the fourth quarter of 1990.

### Technical Contact

J. Hanson, JPL, (818) 354-8148  
A. Sirota, JPL, (818) 354-5696



# Remote Manipulator System — Force Torque Sensor

**FORCE-TORQUE VIDEO  
GRAPHICS DISPLAY**

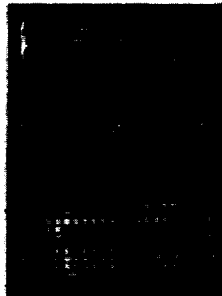

**DISPLAY ELECTRONICS ASSEMBLY (DEA)**

- FLIGHT COMPUTER
- GRAPHICS GENERATOR
- POWER DISTRIBUTION



**DATA COLLECTION ASSEMBLY (DCA)**

- SENSOR ELEMENT
- STRAIN GAUGES
- DATA COLLECTION ELECTRONICS

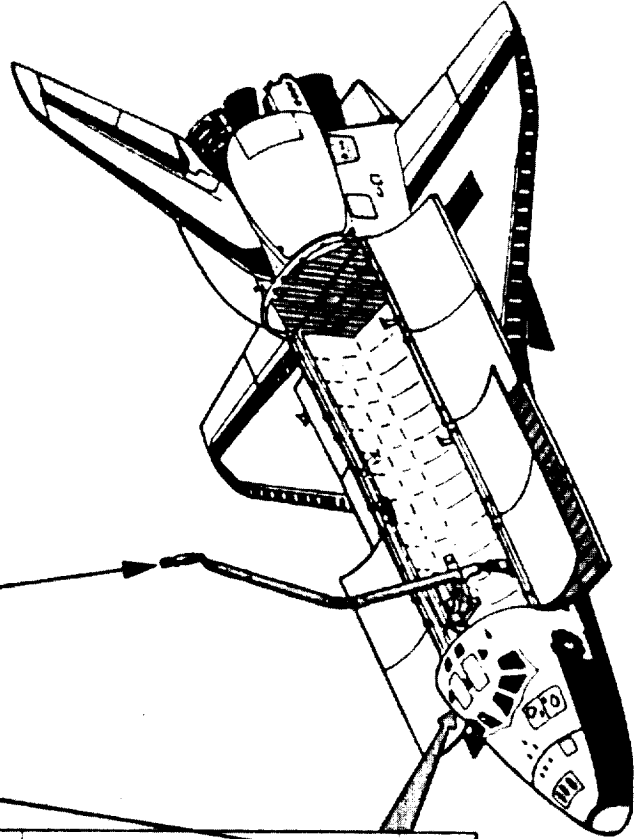
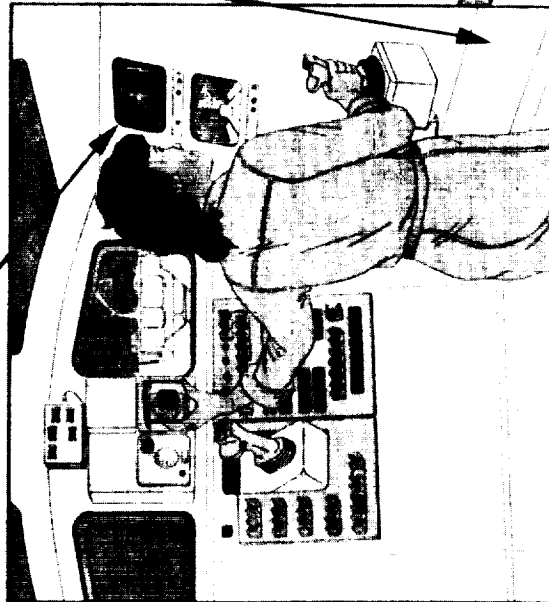

## Traded and Shared Control

The traded and shared control system at the telerobot testbed consists of the following: (1) 6-DOF PUMA 560 manipulators, two for manipulation and one as a camera platform; (2) two 6-DOF Force-Reflecting Hand Controllers, kinematically distinct from the manipulators; (3) an operator interface for autonomous task description and the setting of shared control and teleoperation parameters; (4) task execution sequence control; (5) autonomous task execution primitives including Generalized-Compliant-Motion, Move-To-Touch and Guarded-Motion; (6) dual-arm force reflecting teleoperation; and (7) real-time mixing of autonomous and teleoperation inputs. The system implements a local-remote architecture. The operator specifies tasks and inputs teleoperation commands at the local side, while the remote side executes autonomous tasks and merges the teleoperation inputs with autonomous control. Multiple, programmable modes of both teleoperation and autonomous telerobot control can be established. For example, a camera frame referenced mode is available for teleoperation, which synchronizes the hand controller coordinate reference with that of the manipulator as viewed in the camera image by the operator.

NASA requires traded and shared control as modes of control for the Flight Telerobot Servicer (FTS), NASA's first space telerobot. The laboratory breadboard system at the telerobot testbed provides a means for evaluating the utility of these control modes in performing tasks under space-like constraints, such as occluded views, recovery from task execution errors, and under conditions of time delay. For example, shared control provides the capability

for limiting contact forces and implementing real-time monitoring during teleoperation, features that ensure safety in space telerobotic operations.

Work is under way to include variable, programmable time delay for experimental validation. In the next year, force reflection and dual-arm cooperative control capability will be added to the present shared control capability, and a graphics-based operator interface will be implemented.

### Technical Contact

Paul G. Backes, JPL, (818) 354-3850

# Traded Control

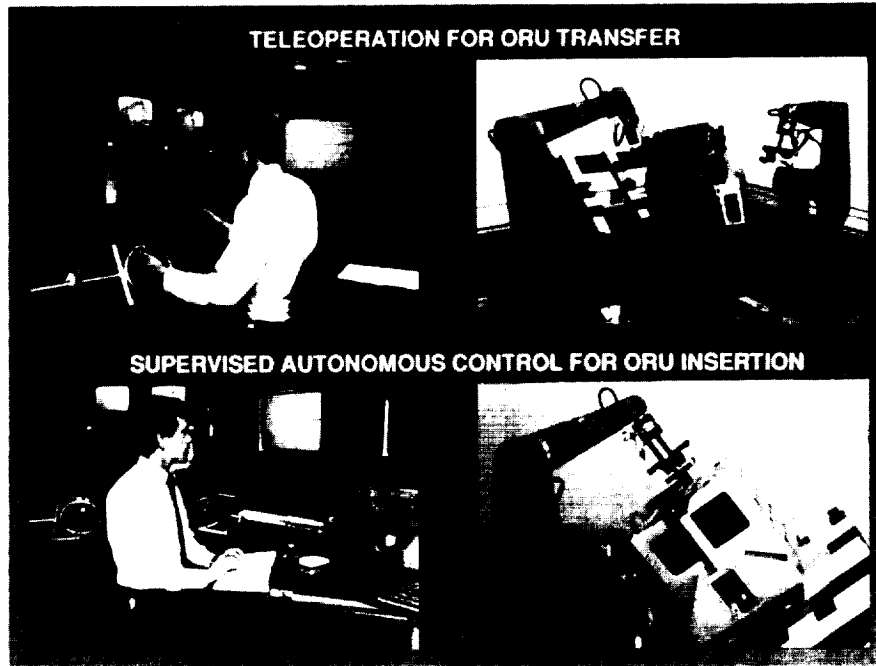

# Shared Control

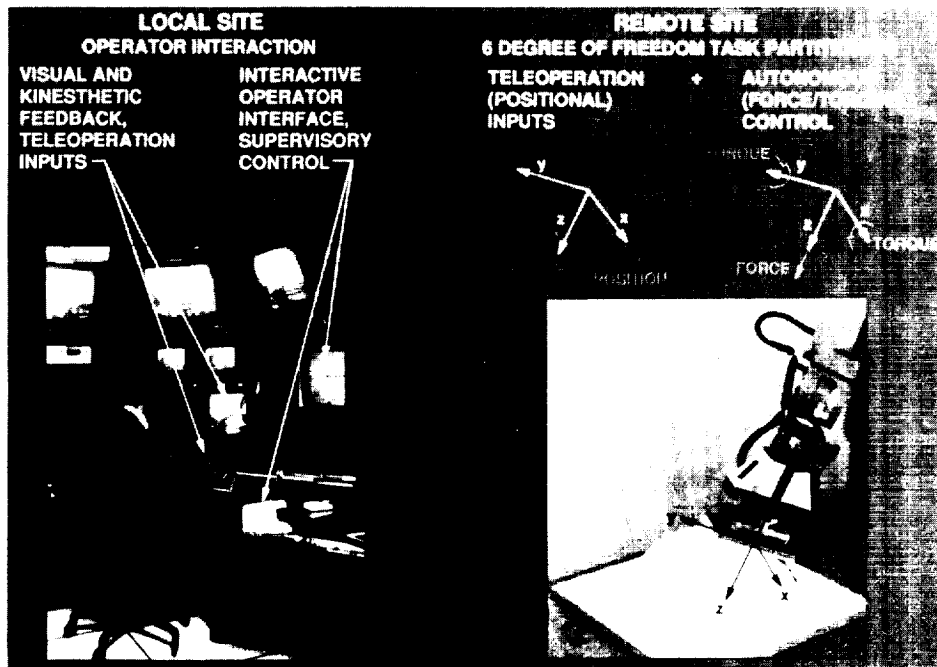

ORIGINAL PAGE  
BLACK AND WHITE PHOTOGRAPH

## Remote Umbilical Development Program

---

The objective of the Remote Umbilical Development Program is to develop an automated umbilical that will track and mate with a launch vehicle in 15 minutes (currently 17 hours manually) and, after all services are performed, disconnect and retract to a safe area; with the capability of remating and stabilizing the vehicle after an on-pad abort. This program is being conducted by the KSC Engineering Development Directorate and their Boeing support contractor.

For normal launches this umbilical system would permit unhurried disconnect and stowage minutes before lift-off. In the event of an aborted launch, it would reconnect quickly and automatically to allow vehicle drain and safe procedures to occur. Currently, the system is able to track, dock, and mate at speeds up to 2 1/2 inches per second, which satisfies current launch vehicle dynamic excursions. The process control loop controls the tracking, mating, connecting, and fluid flow sequences of operation. The mechanical subsystem consists of five major components: ASEA IRB-90 robot, the vehicle flight plate with a 5-dot target, the ground plate, the counterbalance system, and the fluid and electrical lines. The electrical subsystem interfaces all the sensors and hardware to provide status and to transmit commands between the operator or control software and the hardware. The software subsystem consists of two main programs: the Remote Umbilical Tracking and the Remote Umbilical Mechanism. The control system consists of two basic loops: vision tracking and process control. The vision tracking loop has a charged coupled camera connected to a DATAcube™ vision subsystem. Target coordinate data are transferred from the

vision subsystem to a supervisory computer where they are translated into the robot frame and a move command is generated in 33 ms.

A demonstration of the system was conducted in May 1990, and it successfully performed tracking, docking, mating, electrical continuity, and water-flow operations. The technology developed under this project will be used to design ground umbilicals for future launch vehicles.

### Technical Contact

Eric Rhodes, KSC PT-AST, (407) 867-2780

**Remote Umbilical System and Seed Planting Robot**

---

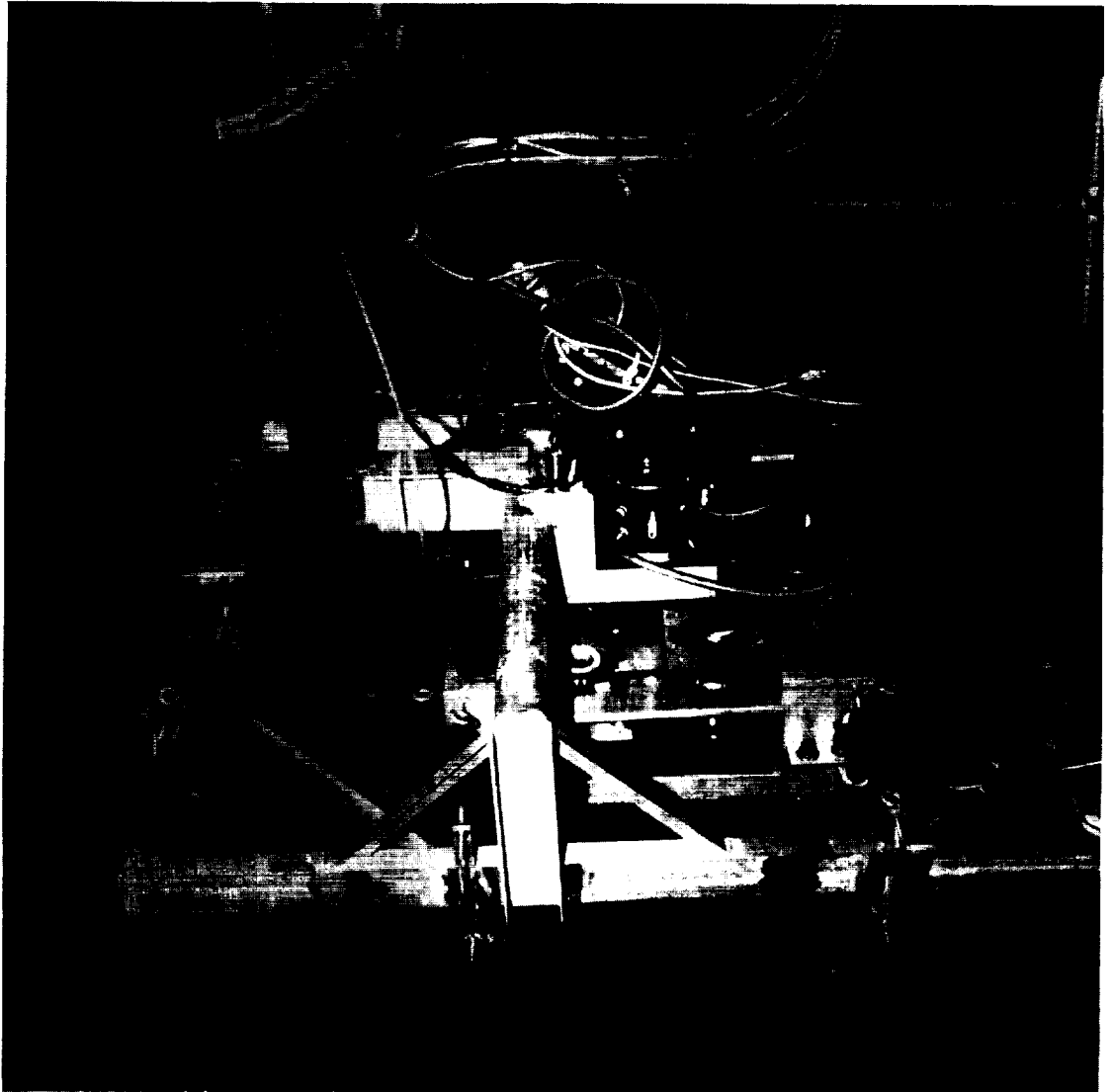

ORIGINAL PAGE  
BLACK AND WHITE PHOTOGRAPH

## Automated Assembly of Large Space Structures

---

The objective of this project is to investigate problems associated with assembling large space structures with automated telerobotic systems and to develop systems and techniques for such assembly tasks. A testbed facility will be designed and built to test hardware, software, and assembly techniques for in-space construction.

The Automated Structures Assembly Laboratory (ASAL) has been developed by LaRC. It consists of a standard industrial robot mounted on a two-axis carriage system to assemble 2-M-long struts into a tetrahedral truss structure mounted on a turntable. Specialized end effector hardware and the software necessary to automate the assembly task are being developed.

The ASAL facility became operational in December 1988, the end effector hardware and software bench testing was completed in January 1989, and actual robotic assembly testing began in February 1989. A force torque zeroing algorithm was developed to enable the end effector and joining mechanisms to work reliably, and by mid-May the first ring of the truss structure was successfully assembled. Development of assembly sequences and paths for the second ring is complete and assembly tests are imminent. Preliminary studies of sensor hardware and algorithms are also under way.

The experience of actually assembling a space truss structure with an automated system will identify practical problems and constraints associated with planned in-space construction. The assembly techniques and methodology as well as the software tools and techniques will be

directly applicable to an in-space construction facility.

During assembly testing for the second truss ring, generalized assembly sequences and paths for all subsequent rings will be developed. Sensor systems will be developed to minimize the need for a priori information. More generalized and flexible end effectors will be developed to perform more varied tasks such as installation of panels and modules on the structure. Knowledge-based sequence and path planning tools will be evaluated for the ASAL assembly tasks.

### Technical Contact

Ralph W. Will, LaRC, (804) 864-6672  
Marvin D. Rhodes, LaRC, (804) 864-3121

**Automated Structural Assembly Laboratory**

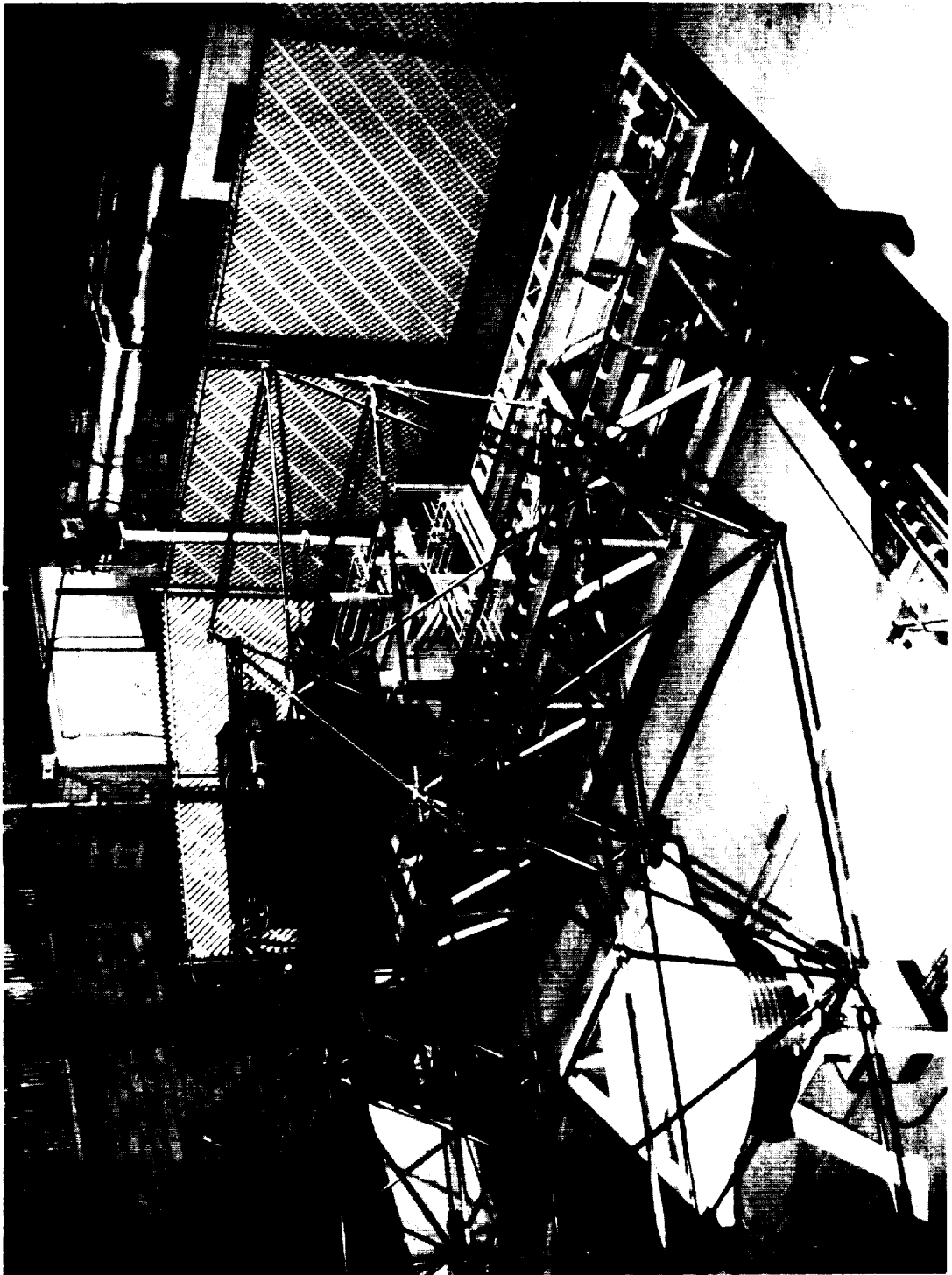

ORIGINAL PAGE  
BLACK AND WHITE PHOTOGRAPH

## LTM — A Dual-Arm Redundant Telerobotic System

---

The objective of this program is to develop, integrate, and demonstrate technology for space telerobots. A dual-arm telerobot incorporating multiple advanced technologies, will be developed and tested in representative tasks.

Early this year, the Laboratory Telerobotic Manipulator (LTM) became operational. Developed by Oak Ridge National Laboratory, based on LaRC requirements, LTM is a dual-arm manipulator that can function as a teleoperator and as a robot. LTM incorporates several unique technologies: (1) 7 DOF providing redundant kinematics, (2) traction (friction) drive for minimum backlash, (3) all wiring and motors internal, (4) fiber optic data lines, (5) modular construction, and (6) high-speed network of distributed computers.

Several of the LTM technologies have been incorporated into the Flight Telerobotic Servicer (FTS) being developed by GSFC: redundant kinematics, internal cabling, modu-

lar construction, and high-speed data. However, FTS will use conventional spur gear drives instead of traction drives. LTM provides the capability to simulate and evaluate software, hardware, and task elements of FTS.

A 6-DOF miniature controller is being interfaced to the 7-DOF LTM using control methods developed at LaRC. LTM will be used to evaluate a number of control input devices. The results of studies will be used to develop metrics for analyzing and predicting performance as a function of task and control.

### Technical Contact

Randolph W. Mixon, LaRC, (804) 864-6695  
Walter W. Hanks, LaRC, (804) 864-6696



**Dual-Arm Redundant Telerobotic System**

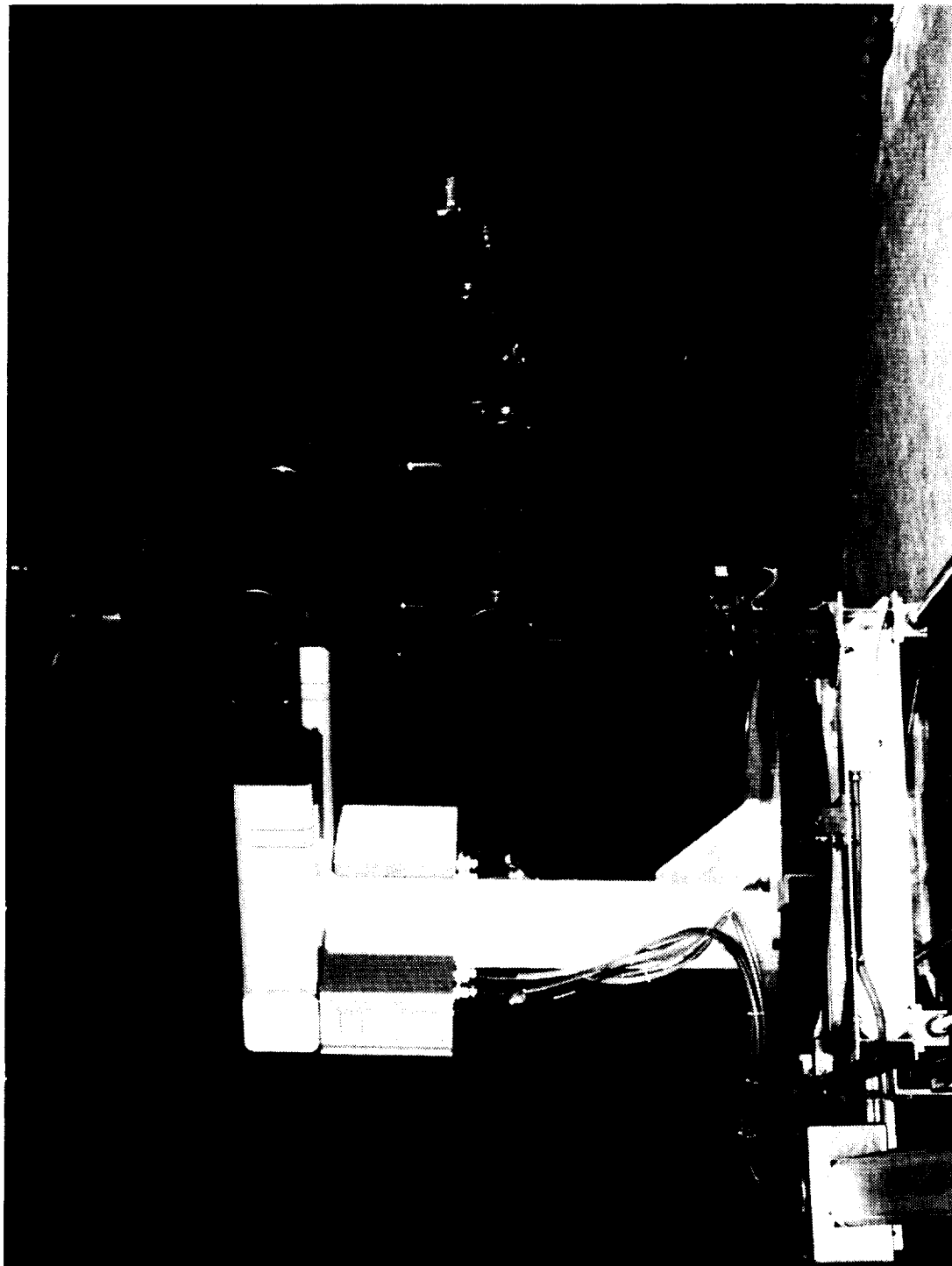

ORIGINAL PAGE IS  
OF POOR QUALITY

ORIGINAL PAGE  
BLACK AND WHITE PHOTOGRAPH

## Telerobotic Task Performance Evaluation

This effort is focused on developing a methodology for the testing and evaluation of telerobotic systems as they perform realistic tasks in real-time. Quantitative measurements are taken of performance relative to the task using repeatable test tasks that can be correlated to standard task analysis tools. These measurements are taken by a sensor task holder (taskboard), which can handle any of several different simulated tasks (either generic or project specific) while measuring positions, forces, and moments across the task interface, and key parameter signals (joint feedback or operator commands) within the telerobot under evaluation. These data can then be either correlated to optimal task performance or used for data base input for task analysis.

Traditional evaluation of telerobotic systems have previously relied on subjective operator evaluations and some piecewise event timings on test tasks devised by the individual tester from available elements. To provide the data needed for spacecraft designers and operations planners, more quantitative data are needed as well as a more systematic method of test evaluation and analysis.

The sensed taskboard and associated data system are under evaluation in the MSFC Flight Robotics Laboratory with some simple task simulators in a NASREM-controlled ProtoFlight Manipulator Arm testbed. Test data collected will be correlated with optimal trajectory data generated from analytical simulators. Enhancements are under way to replace the original spherical bearings and stand of the original taskboard. The planned configuration of a set of generic test tasks is under consideration for review by

OAET and other NASA groups. Tasks are designed to correlate with task analysis "primitives" used in the Flight Telerobotic Servicer Task Analysis Methodology and JPL Telerobotics EVA Joint Analysis System (TEJAS). Project-specific task simulators have been built or are being built for Space Station and Satellite Servicing. Future activities may include a low-cost version of taskboard and generic tasks for distribution to other agency telerobotics laboratories.

### Technical Contact

Thomas C. Bryan, MSFC/EB24, (205) 544-3550

**Robotic Calibrated Taskboard**

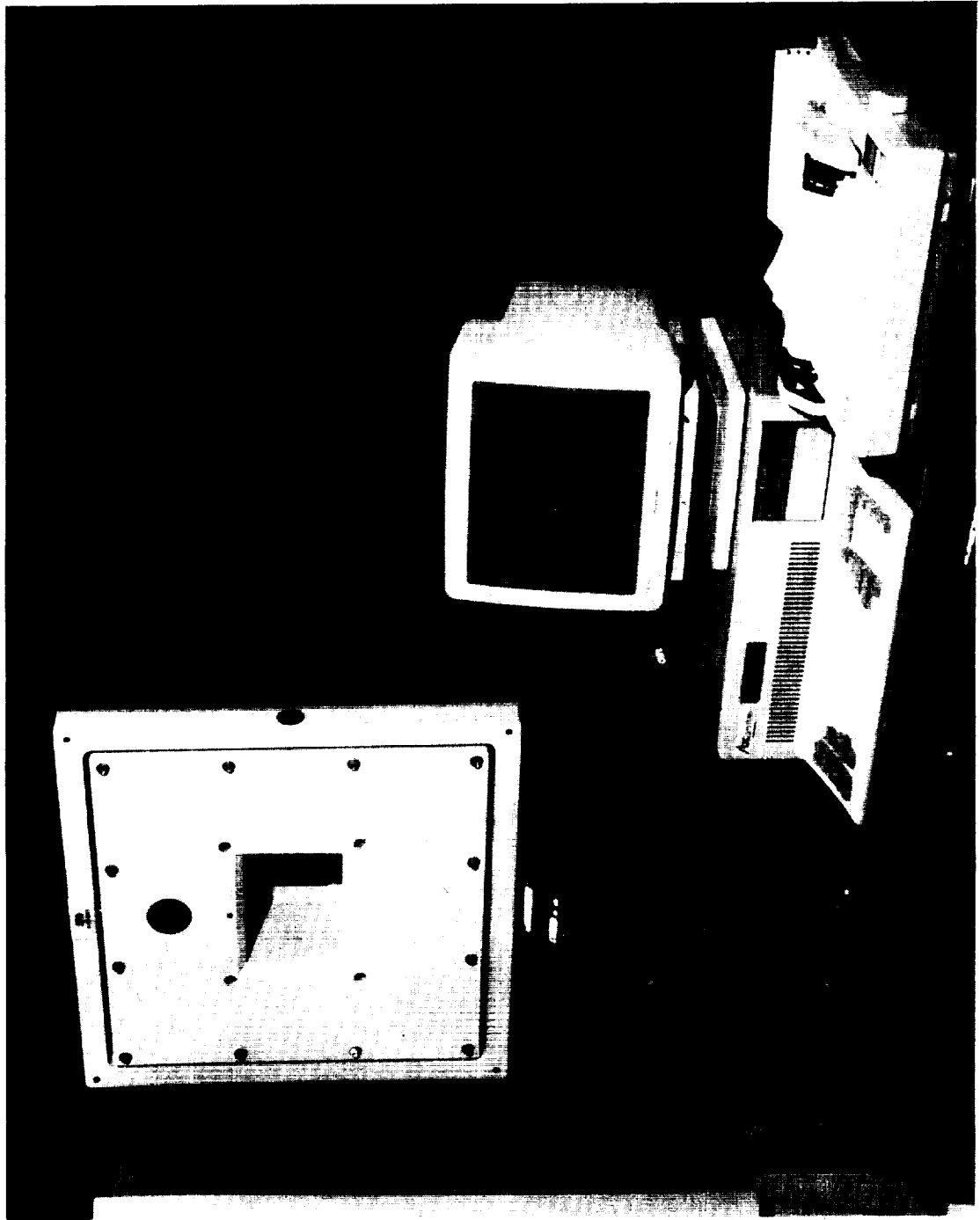

ORIGINAL PAGE  
BLACK AND WHITE PHOTOGRAPH



## Communications

The objective of the Communications Technology Program is to enable data transmission to and from low-Earth orbit, geostationary orbit, and solar and deep space missions. This can be achieved by maintaining an effective, balanced effort in basic, applied, and demonstration prototype communications technology through work in theory, experimentation, and components.

The program consists of three major research and development discipline areas: (1) microwave and millimeter wave tube component research and development; (2) solid-state monolithic integrated circuit research and development; and (3) free space laser communications component and device research and development. The research ranges from basic research in surface physics (to study the mechanisms of surface degradation under high temperature and voltage operating conditions, which impacts cathode tube reliability and lifetime) to generic research on the dynamics of electron beams and circuits (for exploitation in various micrometer and millimeter wave tube devices). Work is also performed on advanced III-V semiconductor materials and devices for use in monolithic integrated analog circuits (used in adaptive, programmable phased arrays for microwave antenna feeds and receivers), on the use of electromagnetic theory in antennas, and on developing technology necessary for eventual employment of lasers for free space communications for future low-Earth, geostationary, and deep space missions requiring high data rates with corresponding directivity and reliability.

Program Manager: Ramon P. De Paula  
NASA/OAET/RC  
Washington, DC 20546  
(202) 453-2748

## Optoelectronics Technology for Space Communications

The objective of this program is to develop and demonstrate the advanced transmitter and receiver optoelectronics technology required for direct detection high-performance spaceborne laser communications systems. The key programs and missions that experience technology from this effort are the Space Station Freedom Laser Communications Transceiver, the Advanced Tracking and Data Relay Satellite Optical Multiple Access communications program, the Flight Systems Demonstration and Development program, communications links to the proposed lunar base, and technology for commercial telecommunications.

The communications system requirements from these missions include high data rate digital transmission (> 1 Gbit/s) for two-way voice, video, and data over a 40,000 km distance. The approach to meet these requirements is research and development of high power (> 1 W average), high electrical to optical efficiency (> 10%) laser transmitters including semiconductor laser diodes and diode-pumped Nd:YAG lasers, high bandwidth (> 1 GHz), high current (> 300 mA) semiconductor laser drivers, high bandwidth (> 1 GHz), high optical throughput (> 90%) Nd:YAG laser modulators, super low ionization coefficient, k (SLIK), low noise, high-gain bandwidth avalanche photodiode receiver detectors, advanced high data rate optimum filter receiver design and development, life testing of semiconductor lasers to ensure space flight applicability, and semiconductor laser beam/power combining techniques for achieving a modulated 1-W, 1-Gbit/s light source.

During fiscal year 1990, GSFC made significant progress

in both transmitter and receiver optoelectronics technology. External cavity semiconductor lasers permit easy access to both longitudinal and transverse laser modes, while achieving high output powers. GSFC developed a 250-mW external cavity semiconductor laser, that produced a diffraction limited output beam, and continued collecting and analyzing laser life test data on the domestic Spectra Diode Laboratory 100-mW semiconductor lasers and several lower power Japanese products. A 380-ps, 300-mA laser current driver was demonstrated that produced 100-mW laser pulses.

Development continued on the Grating Laser Beam Combiner, and aperture and wavelength combining techniques were further explored. In the receiver optoelectronics area, GSFC developed a 220-Mbit/s optical receiver and continued performance and analysis of the 50-Mbit/s world record sensitivity (47 photons/bit) receiver. This included measurements of performance degradation as a function of laser extinction ratio and avalanche photodiode gain. Development continued on improving the performance of 1.06  $\mu\text{m}$  wavelength detectors for high power Nd:YAG lasers. For this purpose, GSFC continued working in conjunction with AT&T Bell to develop a low-noise staircase gallium arsenide avalanche photodiode.

Technical Contact

Michael A. Krainak, GSFC, (301) 286-2646

# Optoelectronics for Laser Communications at GSFC

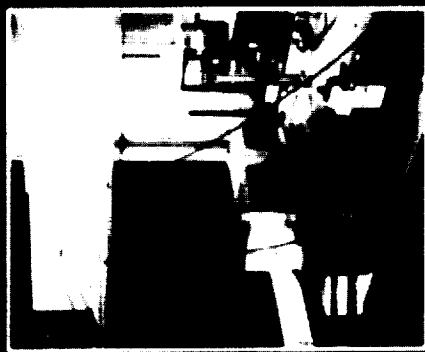

High Sensitivity Direct Detection Receiver  
 • World Record 47 photons/bit  
 • 50 Mbps, 220 Mbps

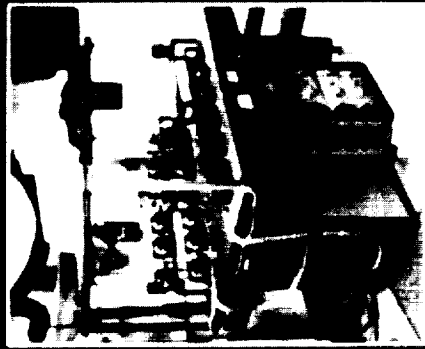

Lifetest Facility

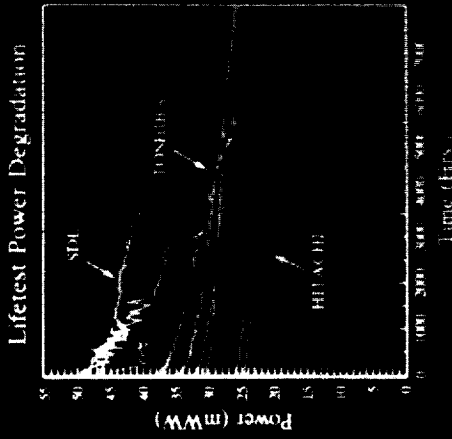

Lifetest Results

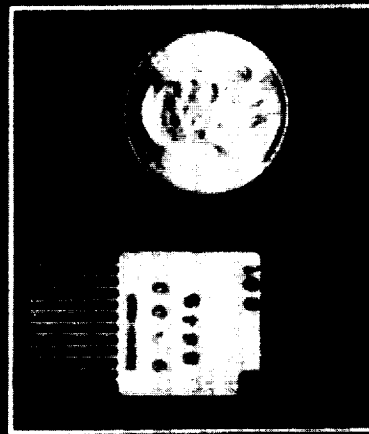

Hybrid Laser Diode Current Driver  
 • 380 ps, 300mA



Compact GRIN Lens  
 External Cavity Laser

## SCOPE (Small Communications Optical Package Experiment) Breadboard

---

The objective of this work unit is to design, assemble, and evaluate a small lightweight (<5 kg) optical breadboard assembly. To keep the mass of SCOPE as low as practical, the design is made very simple. When the optical package is pointed towards the laser beacon, a detector will locate the 532-nm light from the beacon and will command a two-axis steering mirror to align the incoming beacon light with the optical axis of the device. The intensity-modulated output of a diode-laser is then guaranteed to point back at the direction of the beacon. The transmit/receive aperture of the transceiver is only 1 cm, thus producing a relatively broad beam at the far-field, which reduces the complexity of the beam pointing. The entire SCOPE instrument will have a mass of less than 5 kg.

aircraft and/or spacecraft.

The optical portion of the breadboard has been designed, fabricated, and assembled. The quadrant-detector readout and steering mirror electronics have also been designed and tested, and computer analysis and simulation programs have been developed that analyze tracking loop, sensor (quad-cell) noise, and basic servo controller. In progress is the design and hardware implementation of the rest of the transceiver electronics and the alignment of the breadboard optics to demonstrate and evaluate an optical link.

A schematic of the SCOPE is shown along with the optical portion of the transceiver package with the optical components prior to and after assembly into the package.

This breadboard will be the first generation of optical transceivers to be built at JPL. Future generations will include a diode-pumped solid-state laser as the laser transmitter and will be intended for evaluation aboard

Technical Contact

James R. Lesh, JPL, (818) 354-2766

Hamid Hemmati, JPL, (818) 354-4960



# SCOPE (Small Communications Optical Package Experiment) Breadboard

- DESIGNED AND FABRICATED OPTICAL AND ELECTRONICS PORTIONS OF THE TRANSCIEVER PACKAGE
- USES 1 TO 10 MBITS/SEC MODULATION-RATE DIODE-LASER TRANSMITTER AND A 532 NM Nd: YAG LASER BEACON
- TRANSCIEVER WAS DESIGNED TO BE LESS THAN 15 CM X 15 CM X 15 CM IN SIZE AND LESS THAN 5 KG IN MASS

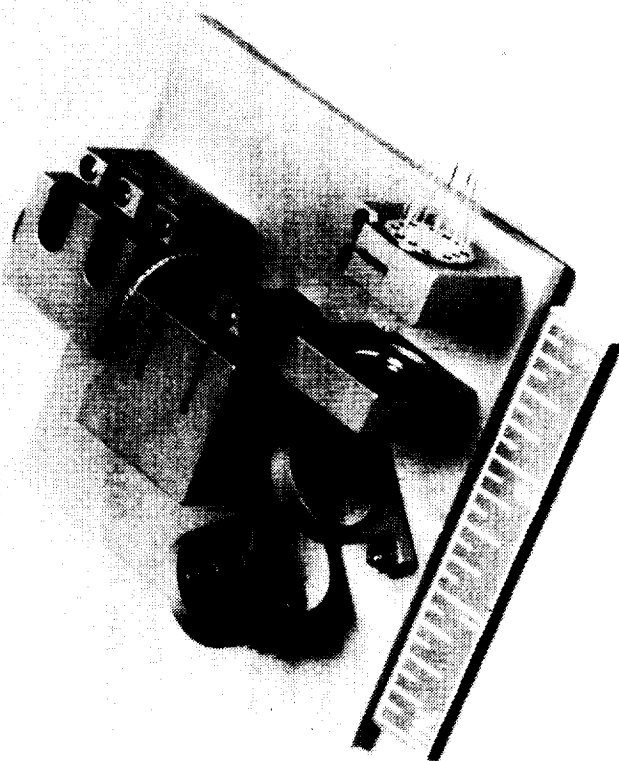
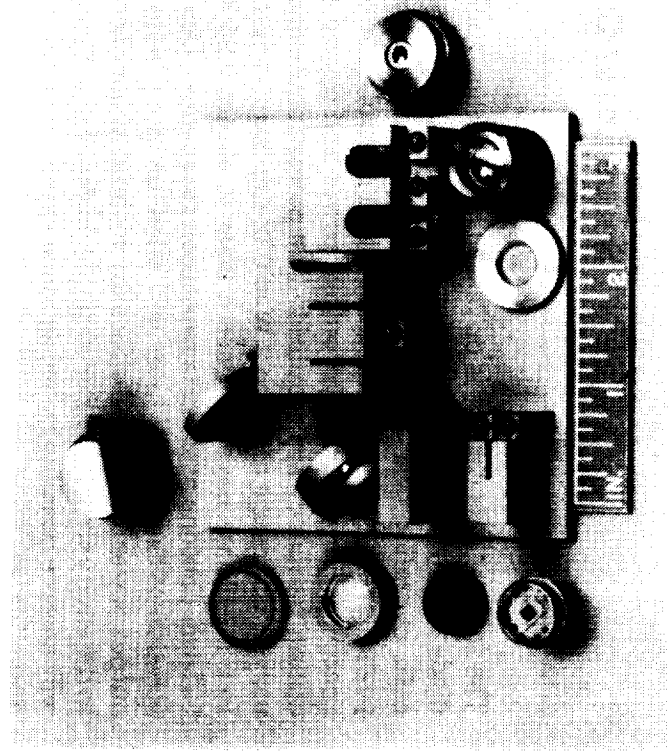
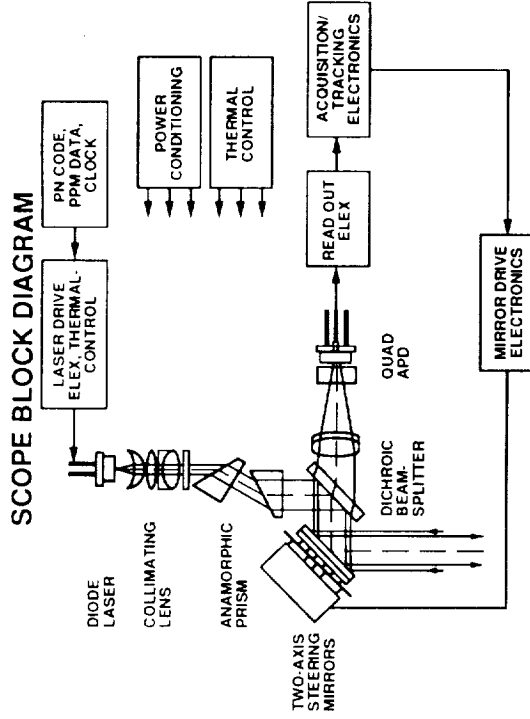

## Space Laser Communication Technology

The focus of this project is on laser transmitters, such as diode-laser-array pumped solid-state lasers, which yield high overall power efficiency, high peak and average power levels, and versatile modulation control. For each space mission a particular output power and pulsed repetition frequency are required. The power requirements vary in the range of 0.2 to 2 W of 532-nm laser radiation. In FY 1990 we have designed a laser to obtain 0.25 W of 532-nm photons at 25 kHz repetition frequency. Demonstration of the 0.25-W laser will allow us to scale-up the output power and overall efficiency without major changes to the cavity structure. For example, higher output powers will become possible by using more powerful input diode pump lasers.

Computer programs were developed to predict the continuous-wave and pulsed output characteristics of the Nd:YAG laser at 1.064  $\mu\text{m}$  and 0.532  $\mu\text{m}$  as a function of the cavity and pump laser parameters, and a laser cavity was designed that minimizes laser threshold and the requirements for beam-shaping optics inside the cavity. It was determined that intercavity losses (due to reflection, bulk scattering, and absorption) are the major contributors to optical-to-optical conversion efficiency. The laser was assembled and characterized for continuous-wave operation. Evaluation of the laser under pulsed-mode of operation and frequency-doubling is in progress.

Schematic of a laser design capable of 0.25 W average output power at 25 kHz repetition-rate is shown. The output of two 1-W diode laser arrays are summed and

focused into a Nd:YAG crystal placed inside a concave-planar laser cavity. An acousto-optic Q-switcher and a KTP frequency-doubler are placed within the cavity to generate pulsed output at 532 nm. The expected continuous-wave power compared with the experimental data and the expected average pulsed output as a function of pulsed repetition-rate are also shown.

### Technical Contact

James R. Lesh, JPL, (818) 354-2766

# Space Laser Communication Technology

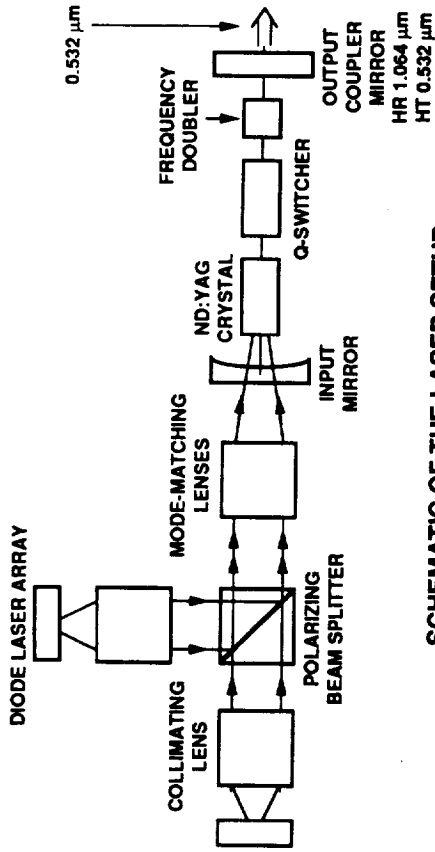

SCHEMATIC OF THE LASER SETUP

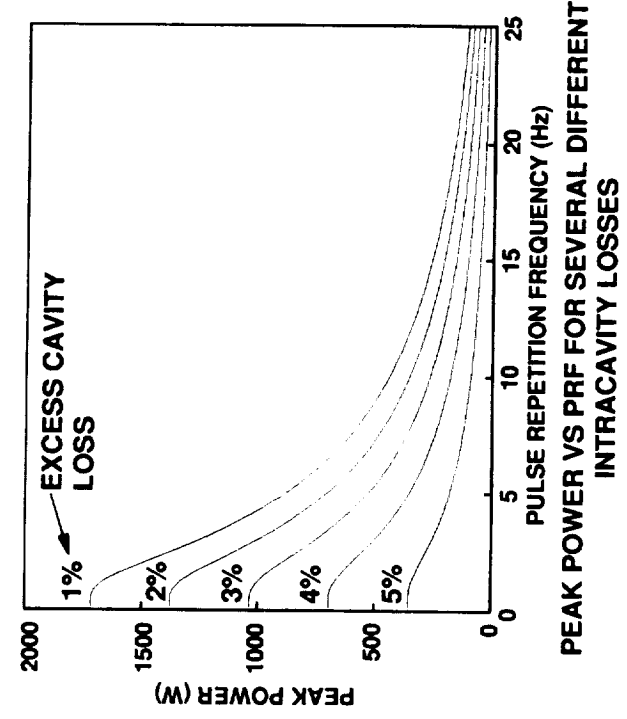
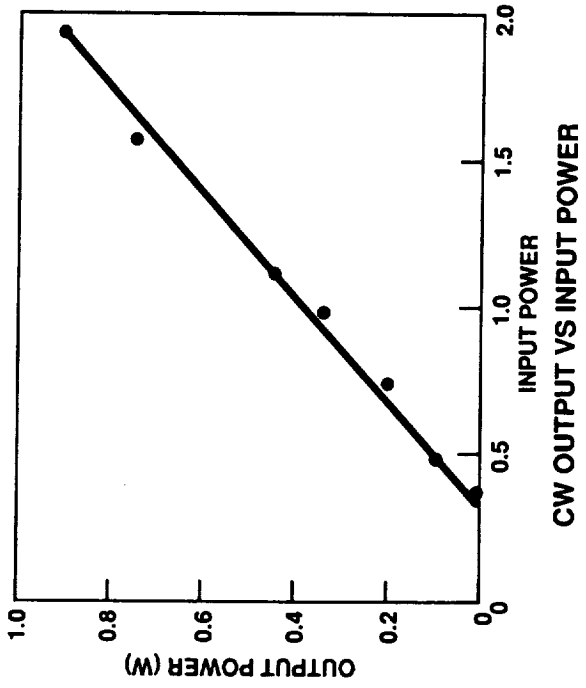

## Configuration Definition Study of Large Deployable Geostationary Antenna Concepts

This study was initiated to evaluate the structural feasibility of placing a large-scale, deployable radiometer antenna system in geosynchronous orbit. The basis for this study is to demonstrate technology development for global change, in particular, for radiometer instruments on the 5-50 GHz range.

The study considered several conceptual radiometer configurations before settling on a folded optics concept proposed by Dr. Peter Foldes. This concept uses a large offset reflector, a subreflector, and a feed system supported by a connecting truss. Design goals of the study are given in Figure 1.

This concept was used on a conceptual definition study conducted for NASA Langley by the Virginia Polytechnic Institute and State University and subcontractor ASTRO, Composite Optics, and ANT, Inc. The study considered several structural and reflector surface concepts, finally selecting the truss structure and rectangular surface facets as the preliminary design elements (Figure 2). The results of the preliminary analysis showed that the maximum antenna diameter achievable with existing launch capabilities is from 25-28 m. A further conclusion from this study is that the large number of piece-parts for a deployable system is a concern to system reliability.

The conceptual design phase has resulted in the initiation of several activities. First, a science benefit study is being conducted by a panel of remote sensing experts to define the uses for a 25-28 m geostationary radiometer (5-50 GHz). Second, a study has been initiated with Research

Triangle Institute to help Langley define and formulate development strategies for state-of-the-art radiometers and feed systems for this reflector system. The radiometer study includes beam efficiency requirements, scanning strategies (mechanical and phased array), and low-noise component requirements necessary for implementation. After completion of the science benefit and radiometer studies, a follow-on design phase is planned to develop a Large Deployable Antenna design, complete with drawings and specifications for a test article suitable for use in NASA and U.S. contractor facilities. A comparable erectable system design is being initiated by NASA Langley Structures Directorate, which is based on the same configuration geometry.

A test article will be constructed based on one of these designs to evaluate readiness for the global monitoring mission.

Technical Contact

Lyle C. Schroeder, LaRC, (804) 864-1832

# Large Deployable Antenna (LDA) Configuration Definition Guidelines

## LDA Configuration

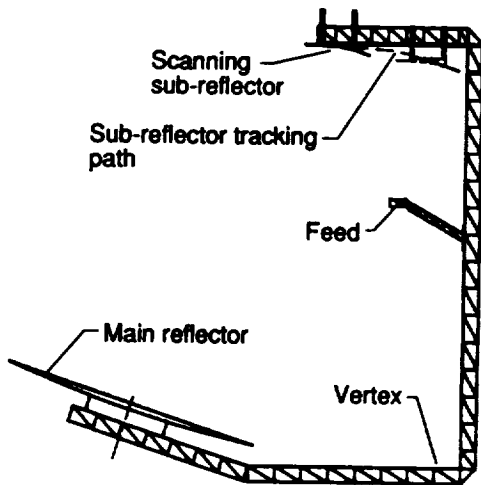

## Radiometer/Antenna Design Goals

Parameters	Requirement and/or Specification
Frequency range	5-50GHz
Main reflector size	40m
Subreflector size	0.5-0.6 x main reflector size
F/D	1.5-2.5
RMS surface accuracy (main & subreflector)	0.1mm
Portion of full disk to scan	
Mode 1 - full disk	$\pm 7.5^\circ$
Mode 2 - limited scan	$\pm 2.4^\circ$
Mode 3 - stare	dwell on small region(s)
Beam efficiency	>90%
Revisit requirements	1-3 hrs.
Thermal differential	100°

## Deployable Truss Reflector Concept (Pactruss Design)

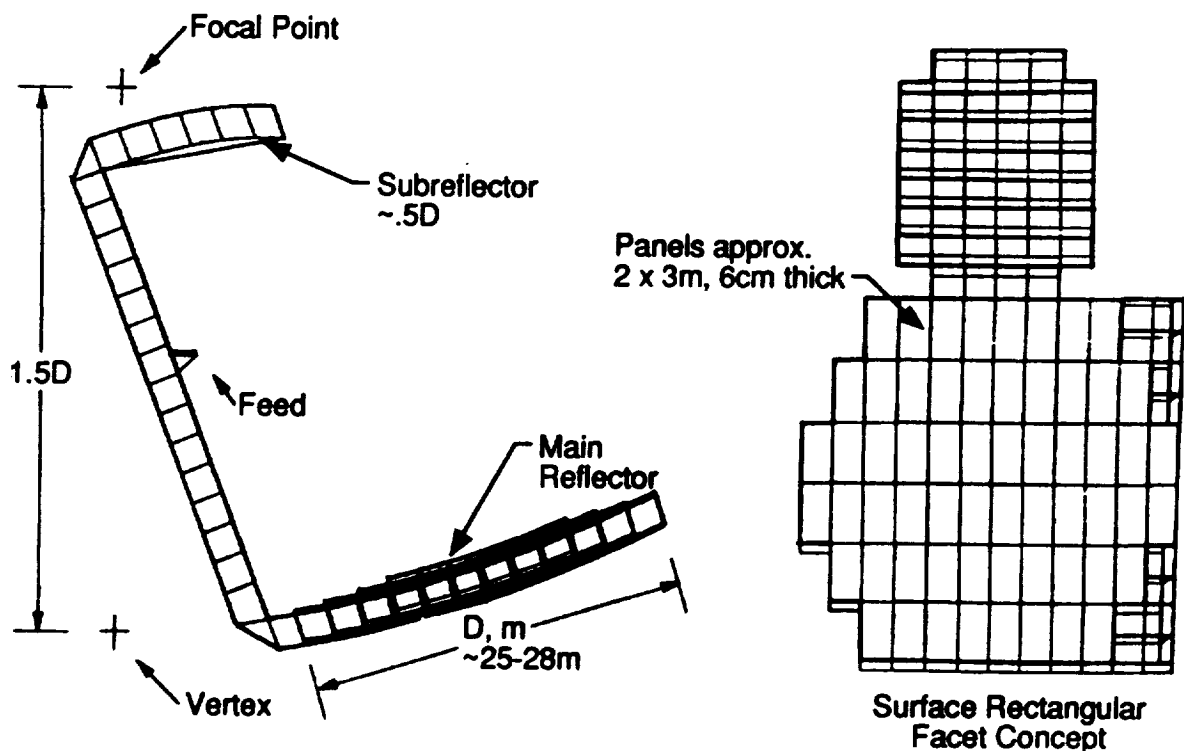

## Large-Scale Antenna Surface Optimization Tests

Langley Research Center has been a leader in technology development for large-scale microwave millimeter wave antennas. In 1985, a 15-m hoop/column antenna, designed and developed by Langley and the Harris Corporation was completed. This antenna was tested at Martin Marietta Denver Corporation to determine its antenna pattern characteristics and at Langley in the 15-Meter Thermal-Vacuum Chamber to determine its vibration characteristics. One lesson learned from these tests is that a large-scale antenna will generally require postdeployment adjustment to obtain the surface figure required for most microwave applications.

Currently, testing is under way to evaluate a computer-controlled actuator system to adjust the reflector surface roughness for the 15-m hoop/column antenna. One quadrant of this antenna was retrofitted with control/actuator motors to allow adjustment of the set of 28 rear control cords which, in turn, provided limited adjustment of the reflector surface.

A computer was used to implement required adjustment to the control/actuator motors, accurate to within 0.001 in. The system is employed by first using an optical sensor (in this case, stereo photography) to determine the offset at retroreflecting targets relative to a best-fit paraboloid. A code is then employed that calculates the optimum control cord adjustments necessary to optimally reduce the surface roughness, and the computer/actuator system adjusts the surface to the new positions. The cycle is repeated if necessary.

In the past year, the installation of the control/actuator system was completed and debugged. A preliminary set of tests indicated that planarity of the hoop structure may have been limiting optimum surface roughness. After reducing hoop planarity residuals by approximately a factor of 3, tests have been resumed. Preliminary results indicate that the limit in surface roughness is approximately 0.060 in. This limit is reached in one to three iterations which, in concept, could be achieved very rapidly in space, if a suitable optical sensor and computer were available.

The results of these surface optimization tests will be used as input test data for a method to reduce effects of surface distortion on electromagnetic signals. Analytical methods will be used to compensate the phase of signals for distortions caused by surface roughness. Prior studies have shown that the effects of surface distortion can be greatly reduced by using multiple antenna feeds. From this analysis, the effective surface roughness reduction can be evaluated.

Technical Contact

Lyle C. Schroeder, LaRC, (804) 864-1832

# CSEI Surface Smoothness Tests



## 15-M ANTENNA SMOOTHNESS OPTIMIZATION

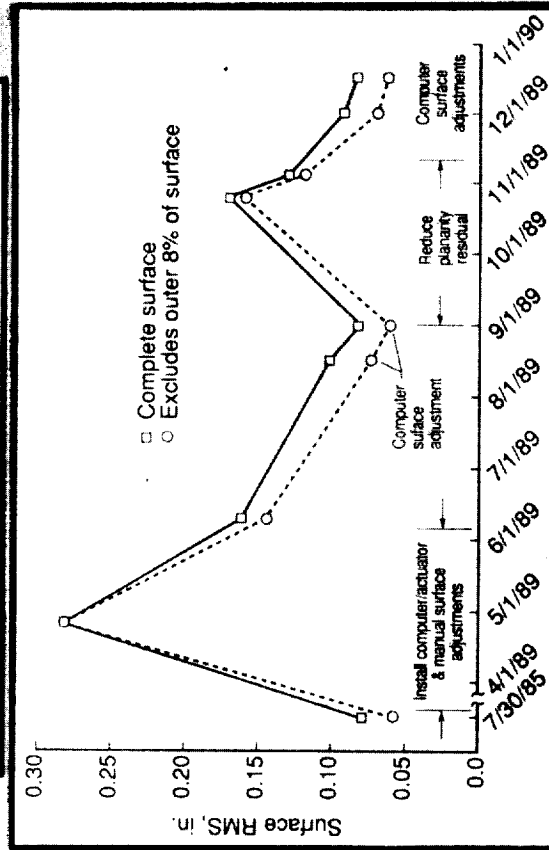

## RESULTS

- Optimization tests conducted over 5 month period.
- Two adjustments of the computer/actuator system reduces the surface smoothness to near the limit (~60mils)
- Adjustments can be made very rapidly.
- Very high speed, onboard adjustments are possible (with high speed optical sensors and a dedicated computer for mensuration and correction calculations).

## 60 GHz Traveling Wave Tube

The objective of this program is to develop a dual mode (75/30 W), 59 to 64 GHz traveling wave tube (TWT) for intersatellite communications. The TWT, designated the 961HA, is being developed by Hughes Aircraft Co., and employs a coupled cavity slow-wave structure with a two-step velocity taper and a NASA LeRC designed isotopic graphite multistage depressed collector MDC. Two TWTs will be fabricated and tested under the contract, with an option to purchase two more. The photograph is of an earlier development model (961H), which demonstrated the required high power and broad bandwidth. The emphasis of this program is the achievement of high overall efficiency, dual-power mode capability in the required operating band, and a substantial reduction in the MDC size and weight.

The design effort has been completed with promising results. Computer modeling indicates that the RF per-

formance of the TWT should be more than adequate. Computed MDC efficiencies in the 94% range indicate that the program objective of an overall TWT efficiency of 40% should be readily achievable.

Fabrication and bake-out of the first TWT has been completed, and testing will commence shortly. Unfortunately, the output match of the TWT deteriorated in the assembly brazing operation. Nevertheless, the output match appears to be adequate over portions of the operating band and will permit the evaluation of the dual mode gun, the MDC performance, and the measurement of the overall TWT efficiency. Fabrication of the second TWT is scheduled for August, 1990.

Technical contact

P. Ramins, LeRC, (216) 433-3521



## 60 GHz TWT for Intersatellite Links

- PREDICTED PERFORMANCE 59 TO 64 GHz BAND  
75/30 WATTS, 40% EFFICIENCY, (CY 90 COMPLETION)
- ENABLES MULTI-GBPS RATE mm WAVE LINKS
- SPACE QUALIFICATION PROGRAM IN PROGRESS BY AIR FORCE WITH NASA  
CONSULTATION

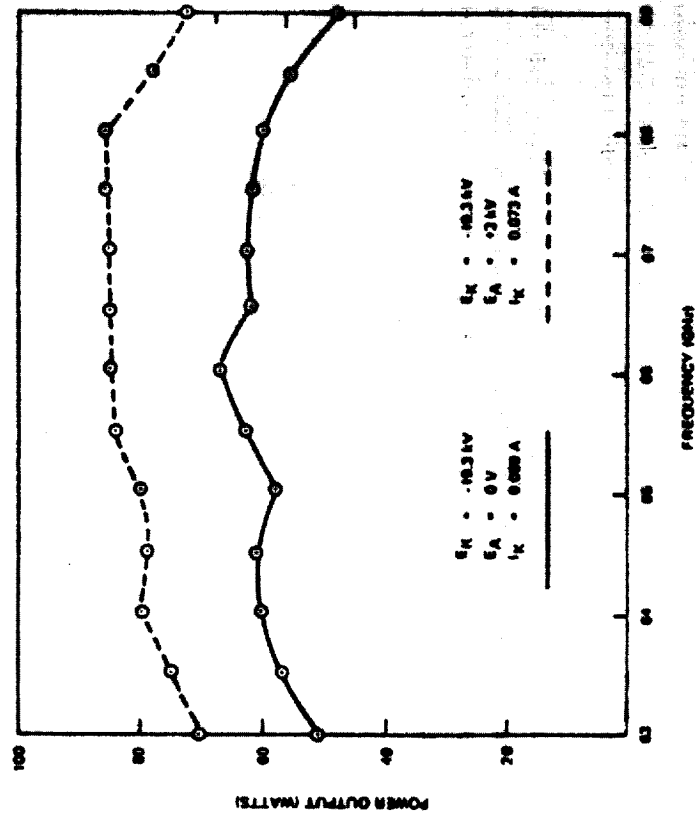
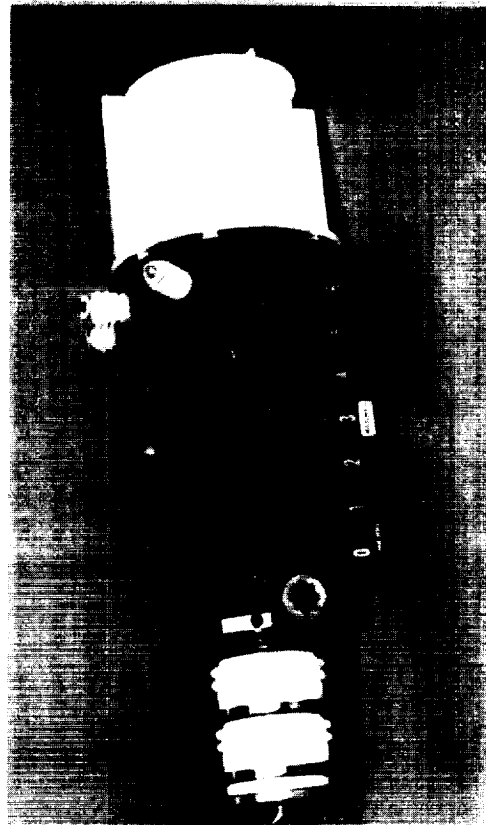

## Barium Dispenser Scandate Cathodes

---

The purpose of this in-house research is to investigate the chemistry of formation and atomic ordering of the Ba-O-Sc<sub>2</sub>O<sub>3</sub>-W surface and to determine their relation to the copious electron emission characteristic of the barium dispenser scandate cathode.

As shown in the figure at left, barium dispenser scandate cathodes can produce high emission current densities at relatively low operating temperatures (e.g., 10 A/cm<sup>2</sup> at less than 900°C). For this reason they are very promising for space tube applications.

At the present time there are no U.S. sources for this cathode. The most successful versions of the scandate cathode have been those developed by Philips of Eindhoven, Holland, and Hitachi of Japan, using different approaches, for potential use in high resolution CRTs. Because of the intense competition in this area, their cathodes are not available to U.S. industry.

A greater knowledge of the chemistry of formation, atomic ordering, and mechanism of operation of the electron-emitting surface, which have not been well understood, could lead to not only further improvements in emission properties, but also to the development of new methods of fabrication. The above research on scandate cathodes is being conducted by Dr. Ralph Forman of Analox Inc.

A thin replica of the barium dispenser scandate cathode electron-emitting surface has now been successfully synthesized on a tungsten foil substrate. The process used in the deposition of the film is depicted in the figure on the

right. The principal finding is that the electron emission and rate of Ba desorption are critically dependent on the presence of oxygen chemically bound to the Ba and Sc.

Future work will consist of further quantifying the film formation, identifying precisely the chemical states of the various elements, and investigating the effects of substrate materials other than tungsten.

Technical Contact  
E. Wintucky, LeRC, (216) 433-3510

## Thin Film Scandate Cathode

- **CATHODES PREVIOUSLY PRODUCED BY HITACHI & PHILLIPS - NOT AVAILABLE TO US INDUSTRY**
- **MORE THAN ORDER OF MAGNITUDE INCREASE IN CURRENT DENSITY AT SAME CATHODE TEMPERATURE OFFERS PROMISE OF VERY LONG LIFE**
- **LERC IN-HOUSE RESEARCH EXPLAINS MECHANISM OF OPERATION - PROVIDES BREAKTHROUGH OPPORTUNITY**

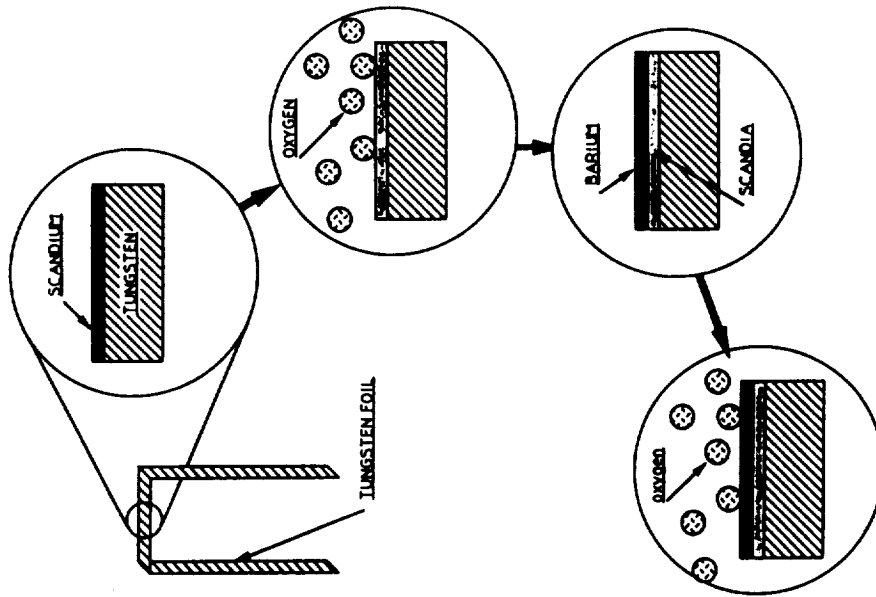

**BARIUM OXIDE ADHERES STRONGLY TO SCANDIUM OXIDE PRODUCING STABLE HIGH EMISSIVITY SURFACE**

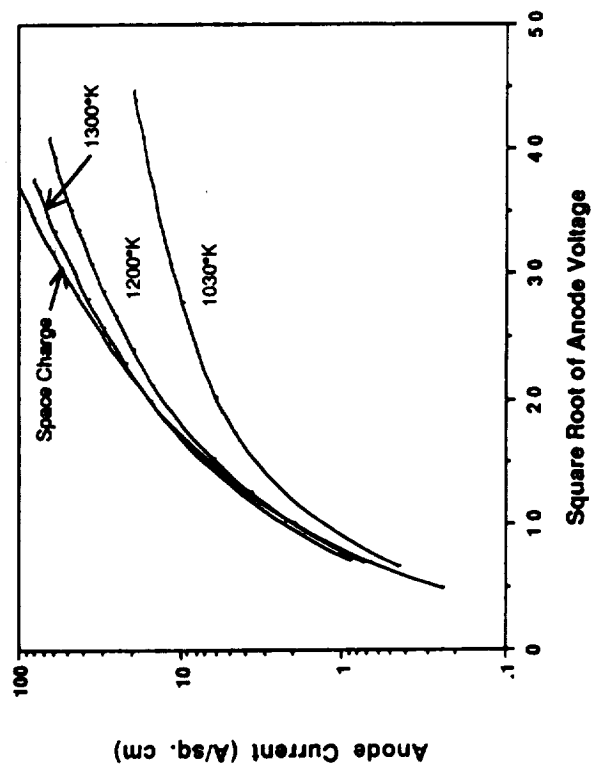

## High-Efficiency Traveling Wave Tube Amplifiers for Deep Space Communications

Ongoing programs at LeRC continue to provide the technologies needed for high-efficiency millimeter wave traveling wave tube amplifiers (TWTAs) for planned NASA deep space missions.

A current objective of this effort is to develop, in a contractual and cooperative effort with Varian Associates, Inc., a very high efficiency, high data-rate TWTAs operating in Ka-band (32 GHz) for the Cassini Mission to Saturn planned for launch in 1996. The required RF power output of the tube (TWT) is 7 W, while the DC input power to the electronic power conditioner (EPC) cannot exceed 20 W. Achieving this performance goal will essentially double the efficiency of Ka-band TWTAs presently available at this power level. In order to accomplish this significant increase in efficiency, several LeRC-developed technologies involving computer-aided design and experimental development efforts are incorporated into the TWT. These advances include improving the interaction between the electron beam and the electromagnetic wave as well as maximizing the recovery of energy in the spent electron beam.

An advanced helix interaction section with a LeRC-designed dynamic velocity taper (DVT) is a feature of the TWT. This "tapering" results in better synchronization between the circuit wave and electron bunches than can be realized with a constant helix pitch. The accompanying figure presents the power transfer function advantage of the use of the DVT helix over a uniform-pitch helix TWT design, providing sharply higher RF output power over the entire range of exciter (input drive) power shown. The design of

a high-efficiency multistage depressed collector (MDC) is also contributed by LeRC. In addition, during the fabrication process, the MDC electrode surfaces will be treated at LeRC using an in-house-developed process to suppress secondary electron emission.

The program will conclude with the delivery of four fully functional engineering model TWTs along with one breadboard model EPC. Coordination with JPL has produced packaging and testing requirements for the hardware delivered from this research and development program, to be a suitable immediate predecessor for the development of a flight model TWT for the Cassini Mission.

### Technical Contact

Arthur N. Curren, LeRC, (216) 433-3519

# High-Efficiency TWT Technology For Deep Space

---

Transfer Functions

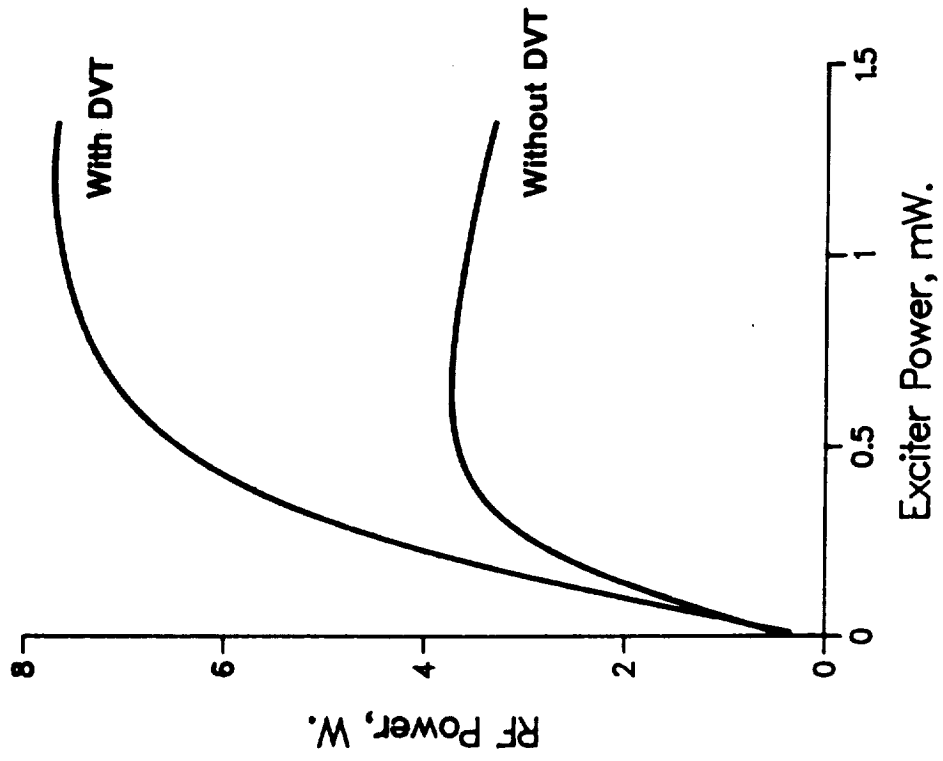

## High-Efficiency UHF-TV Klystron

The objective of this program was the application of NASA OAEF-developed multistage depressed collector (MDC) technology to double the overall operating efficiency of klystrons used in terrestrial UHF-television transmitter service. The program, was jointly sponsored by NASA, Varian Associates, and a cooperative group that included the National Association of Broadcasters, the Public Broadcast System, and some transmitter manufacturers.

Computer modeling codes were developed to model the RF performance of the UHF Klystron and to produce and evaluate spent-beam refocuser and MDC designs. An experimental program was conducted to verify the predicted MDC Klystron performance, and very good agreement was obtained between the computed and measured performance. The MDC Klystron, equipped with a four-stage collector with carbon-coated electrodes reduced the electrical input power for television operation to less than one-half compared to typical existing transmitters. Subsequently, satisfactory signal-quality performance was demonstrated under simulated television conditions.

The MDC Klystron amplifier for UHF was selected by *Research and Development* magazine for an "R & D-100" award as one of the 100 most-significant new technical products for 1989. The first two MDC Klystrons went into actual UHF-TV transmitter service early in 1990. It has been estimated that a typical UHF station could save \$75,000 per year in power consumption by upgrading its transmitter; nationwide, the savings could exceed \$25 million a year.

Technical Contact

P. Ramins, LeRC, (216) 433-3521

**UHF Television Klystron with MDC**

ORIGINAL PAGE  
BLACK AND WHITE PHOTOGRAPH

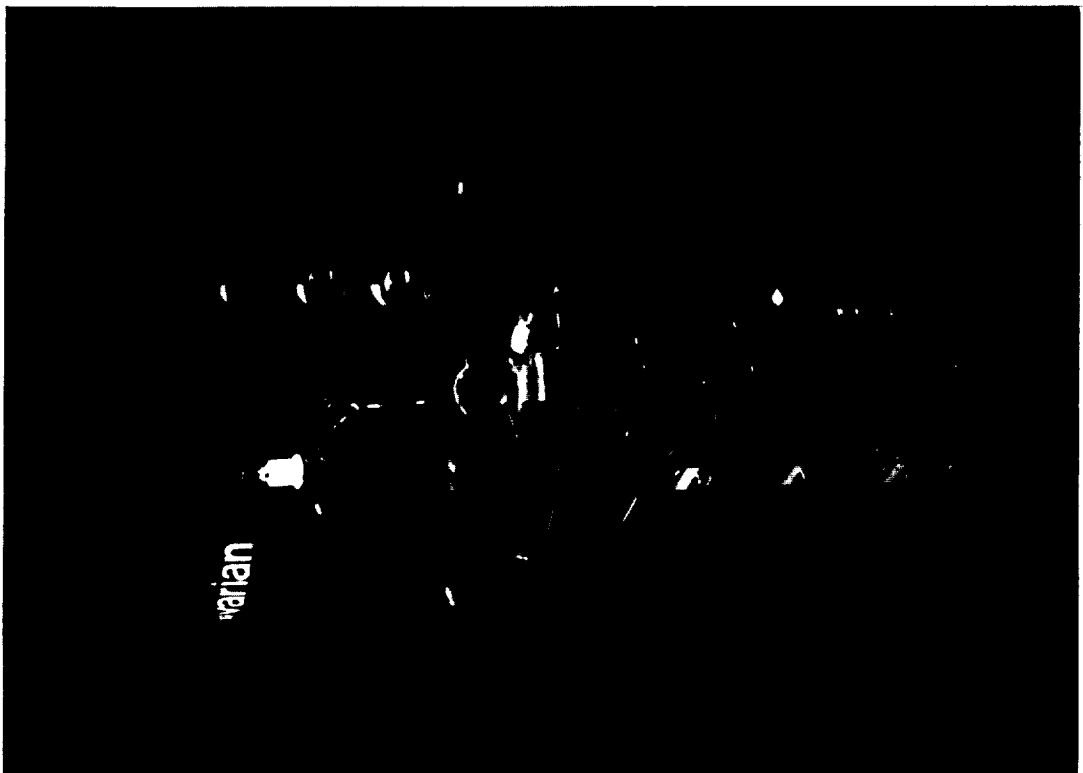

ORIGINAL PAGE IS  
OF POOR QUALITY

## Scandate Oxide-Coated Cathodes

The purpose of this effort is to evaluate the performance of oxide-coated cathodes with scandium oxide ( $\text{Sc}_2\text{O}_3$ ) added to the oxide coating and consequently to determine their potential for space tube applications.

Oxide-coated cathodes have a long history of successful application in NASA space tubes and, in comparison with barium dispenser thermionic cathodes, have advantages of simpler construction and lower operating temperatures. However, oxide cathodes until now have been relatively limited in emission current capability and therefore unsuitable for space tube applications requiring cathode current densities of more than  $0.5 \text{ A/cm}^2$ . Improvements in emission current density, e.g.,  $1 \text{ A/cm}^2$ , together with lifetime and reliability, could be of considerable benefit to NASA.

During the past decade, Mitsubishi Electric Corp of Japan, driven by the need to develop brighter electron sources for high resolution CRTs, achieved a major advance in oxide-coated cathode technology. With only a relatively minor modification in cathode fabrication, the addition of a small amount of  $\text{Sc}_2\text{O}_3$  to the oxide coating, cathode performance was significantly improved. Lifetimes of more than 30,000 hours at an average cathode loading of  $2 \text{ A/cm}^2$  were reported.

The only work on this type of cathode being done in the United States is that supported by NASA. Pulse tests (0.1% duty cycle at a peak current density of  $6 \text{ A/cm}^2$ ) confirm the capability of superior performance. Compared to cathodes with standard coatings, the  $\text{Sc}_2\text{O}_3$  cathodes

showed significantly shorter activation times, lower operating temperatures, and better life performance. Reduced operating temperature is directly related to increased cathode life.

A comparative life test at  $1 \text{ A/cm}^2$  continuous emission under tube-like conditions of two oxide-coated cathodes and two standard oxide-coated cathodes will begin in August 1990. As shown by the initial activity curves in the second of the two accompanying figures, the  $\text{Sc}_2\text{O}_3$  oxide-coated cathode has a significantly lower operating temperature for the same emission current density.

### Technical Contact

E. Wintucky, LeRC, (216) 433-3510



## Scandate Oxide-Coated Cathodes

**CATHODES WITH  $Sc_2O_3$  ADDED TO OXIDE COATING DEMONSTRATED BY JAPANESE TO HAVE LOWER OPERATING TEMPERATURES AND HIGHER CURRENT DENSITIES THAN STANDARD OXIDE CATHODES - 30,000 HOURS LIFE AT 2 A/cm<sup>2</sup> REPORTED**

**NOW USED COMMERCIALY IN HIGH RESOLUTION, LARGE AREA TVS - GOOD POTENTIAL FOR SPACE TUBE APPLICATIONS**

**PRELIMINARY RESULTS OF NASA LERC SUPPORTED TESTS CONFIRM CAPABILITY OF SUPERIOR PERFORMANCE**

**LIFE TESTING AT 1 A/cm<sup>2</sup> CONTINUOUS EMISSION UNDER TUBE-LIKE CONDITIONS ABOUT TO BEGIN**

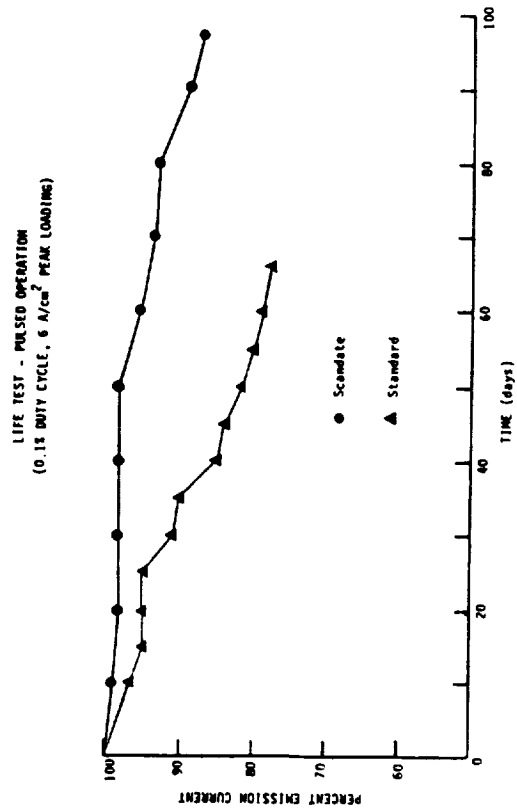

INITIAL ACTIVITY CURVES FOR CW OPERATION AT 1 A/sqcm

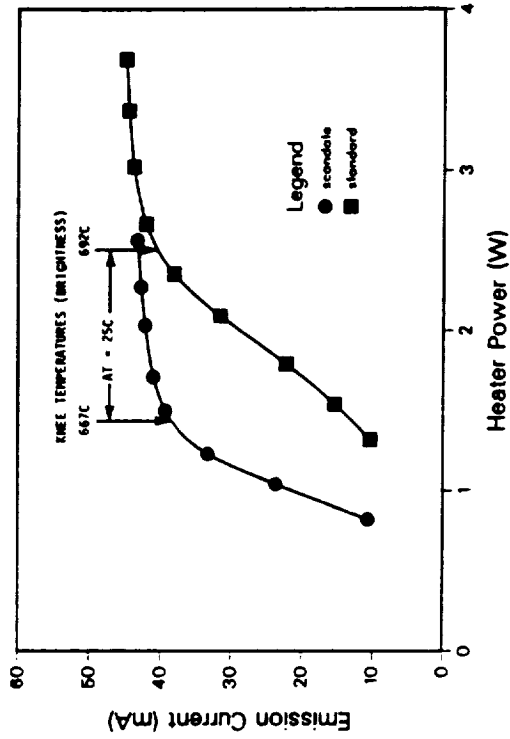

## Submillimeter Wavelength Backward-Wave Oscillator

The backward-wave oscillator (BWO) is an electron beam device with potential application as a voltage tunable local oscillator for spectrometers deployed above the Earth's atmosphere. The project goal is to produce an oscillator with an operating frequency of 2 THz.

The BWO appears to be the best choice to support this application. It is voltage tunable, can be phase locked, and can provide sufficient power for almost any of the envisioned systems including arrays of detectors for quick data recovery. The BWO program has produced a number of successful design innovations, including a microfabricated circuit on a diamond substrate, an optical output coupler, and a high impedance slow-wave structure.

The microfabrication technique developed at MIT Lincoln Laboratory has permitted the use of an interdigital line circuit. This is a fundamental backward-wave structure and has a higher impedance than the vane structure which is usually used at high frequencies. The circuit is etched onto a diamond substrate to facilitate the problem of passive cooling in space. It was found that a quasi-optical output coupler permits wideband operation. A tapered slot line antenna, having a cover plate to confine the radiation, feeds a sapphire lens collimator and transmits it through a window (quartz or sapphire) in the vacuum envelope.

A lanthanum hexaboride (LaB6) cathode is being installed into the experiment at LeRC. This cathode has the promise of long lifetime and is capable of the high emission densities required to overcome the severe losses occurring at THz frequencies. At this time the BWO has demonstrated a continuously tunable bandwidth of 78% (137-311.5 GHz). A measurement made at LeRC with a Golay cell detector calibrated against a CO<sub>2</sub> pumped far infrared laser indicates that the output power is 21.5 mW.

### Technical Contact

Norbert Stankiewicz, LeRC, (216) 433-3674

## Submillimeter Backward-Wave Oscillator

- **POWER OUTPUT 21 mW AT 270 GHz**
- **CONTINUOUSLY TUNABLE FROM 137 TO 311 GHz**
- **REDESIGNED ELECTRON GUN FOR CW OPERATION**
- **SAPPHIRE LENS FOR QUASI OPTICAL OUTPUT COUPLER**
- **NOVEL CIRCUIT DESIGN FOR EFFICIENT, COMPACT OSCILLATOR**

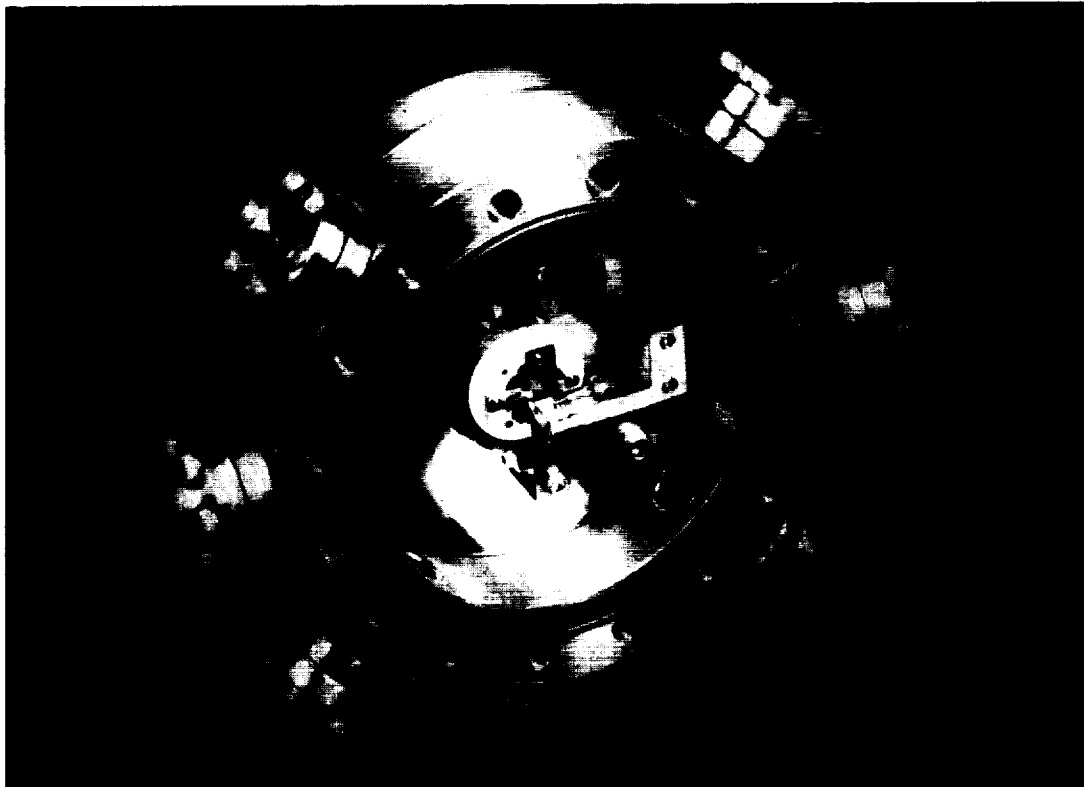

## Theoretical Studies of Cathode Surfaces

The purpose of this effort is to calculate the microscopic electronic properties causing the significant variations in electron emission enhancement (effective work functions) observed among the refractory 5d transition metals and alloys (e.g., W, W-Os, W-Ir) used for the electron-emitting surfaces of barium dispenser thermionic cathodes.

The basic approach consists of the application of modern computational methods of theoretical quantum chemistry (mainly the fully relativistic, scattered wave, X-alpha atomic cluster formalism) to the calculation of the electronic structure and charge transfer characteristics associated with the chemisorption of Ba and O on cathode-like surfaces. The theoretical study is being performed in house under contract by Dr. Wolfgang Mueller of Anatatom, Inc., using the CRAY computer facilities at LeRC.

Relativistic cluster calculations of important microscopic properties, such as dipole moment and dipole energy, have been carried out for Ba and O adsorption on representative 5d transition metals and alloys, using the dominant crystal faces present on actual cathode surfaces. The theoretical results show that the substrate crystal structure and crystallographic orientation play a dominant role in determining these properties. For the first time a potentially unambiguous and rigorous explanation for the relative effective work function minimum occurring with Ba/O adsorption on Os, W-Os, and W-Ir surfaces, which have the hexagonal close packed crystal structure, is now possible.

The figure on the left shows the effective work function

minimum for the Ba/O complex relative to W and Pt, which have body-centered cubic and face-centered cubic crystal structures, respectively. As shown in the figure on the right, the relative surface dipole moment for the Os substrate is also a minimum, whereas the dipole energy is a maximum (consistent with the experimentally observed higher Ba/O binding energy and greater thermal stability). The work function minimum, which occurs at higher Ba/O surface coverages, is determined by the competing effects of large dipole moment and the depolarization induced by interacting dipoles. Too large a dipole moment leads to greater depolarization and correspondingly a higher value for the work function minimum, as is illustrated for W and Pt.

Technical Contact

E. Wintucky, LeRC, (216) 433-3510

## Theoretical Studies of Cathode Surfaces

- INVESTIGATED EFFECTS OF SUBSTRATE CRYSTAL STRUCTURE ON SURFACE DIPOLE PROPERTIES OF BaO ON W(bcc), Os(hcp), Pt(fcc), AND ALLOY SURFACES USING RELATIVISTIC CLUSTER APPROACH.
- OPTIMUM FOR SURFACE DIPOLE (WORK FUNCTION) AND DIPOLE ENERGY (THERMAL STABILITY) FOUND FOR BaO ON Os AND W-Os ALLOYS (hcp).
- INTERPLAY BETWEEN MAGNITUDE OF SURFACE DIPOLE AND INDUCED DEPOLARIZATION OFFERS LONG AWAITED EXPLANATION OF EMISSION ENHANCEMENT OBSERVED FOR BaO ON W-Os ALLOY SURFACES.

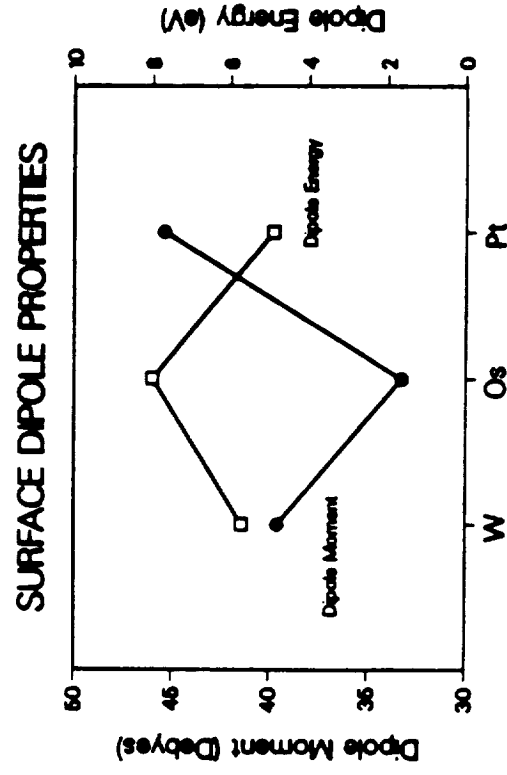
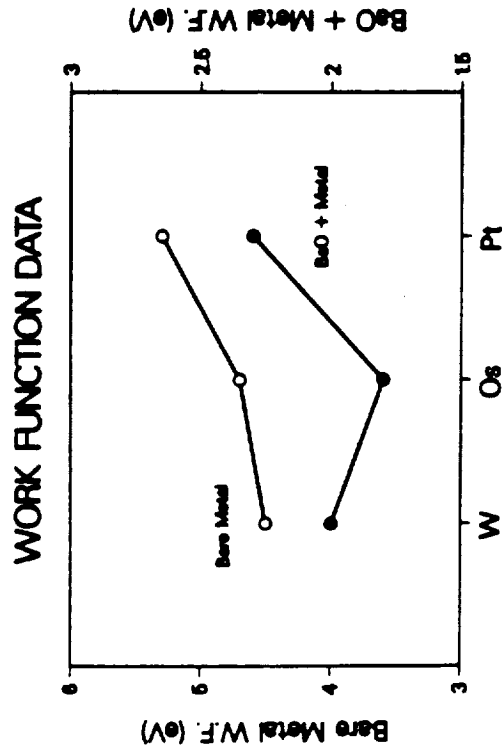



## **Computer Sciences**

The overall goal of the Computer Science Research Program is to foster the advancement of computing technology targeted at aerospace applications. This goal is being realized through a program of basic research and experimentation that focuses on developing core skills within the Agency in disciplines critical to NASA and on maintaining a strong university base of fundamental research in aerospace computer science.

The research program is improving the state of knowledge of fundamental aerospace computing principles. Computing technology in crucial space applications, such as software engineering for very reliable systems and information extraction from data collected by scientific instruments in space, is also being improved.

The program includes the development of special algorithms and techniques to exploit the computing power provided by high performance parallel processors and special purpose architectures. Problem areas of importance include computational fluid dynamics, computational chemistry, structural analysis, signal processing, and image processing. The computer architectures of interest include common and local memory multiprocessors, single-instruction stream/multiple data stream processors, static data flow processors, systolic arrays, and heterogeneous multiprocessors with custom processors. Research is conducted in programming languages and environments, parallel and distributed operating systems, and performance measurements.

Research is also being conducted in the fundamentals of data base logic. This work has resulted in the development of a common user interface for accessing data from several data bases even when the data bases being accessed have very different structures. This work provides the foundation that will enable NASA space data users access to multiple data bases independent of the physical distribution or structure of the data bases. This work will reduce the cost of such investigations and enable data base intensive scientific research that would otherwise be unaffordable. Other work is under way to develop and test an expert system that can serve as an assistant to researchers analyzing space-derived data.

Research is being conducted to improve techniques for producing reliable computing systems. That work is directed at both reducing the number of faults in software and making systems that are tolerant to faults. New approaches and methods for software management and engineering have been devised and are now being evaluated under real working conditions. In addition, emphasis is being placed on the automatic reuse of software to lower software production costs. Future objectives in a new software engineering initiative will include research on the theoretical foundation and extending and evaluating approaches for developing reliable complex software.

The Computer Sciences Program is coordinated with the Space Station's Software Support Environment (SSE) and the DoD-sponsored Software Engineering Institute (SEI) and ADA. NASA also participates with DoD and other national bodies on several advisory and technical coordination committees.

Program Manager: Paul H. Smith, (202)453-2753  
Paul Hunter, (202)453-2704  
NASA/OAET/RC  
Washington, DC 20546

## Empirical Investigation of Sparse Distributed Memory Using Discrete Speech Recognition

---

The primary purpose of this research is to use discrete speech recognition to identify factors that affect the performance of Sparse Distributed Memory (SDM) for highly correlated data.

The original theory of SDM assumed, for mathematical convenience, that data were distributed uniformly throughout the address space. This assumption is invalid for real-world data.

A progressive series of experiments using spoken digits demonstrates the efficacy of several adaptations of SDM for dealing with real-world data: e.g., error-correcting codes for labels, speech patterns used to determine placement of memory cells, a conservative write rule, choice of appropriate SDM model — the selected-coordi-

nate design worked best. Simulations using these adaptations showed dramatic performance improvements: from 49.6% to 99.3% accuracy on the test sets.

The experiments reveal the importance of matching details of memory architecture to the data of interest and to the scheme for encoding the data as binary patterns.

We plan to extend our research to use continuous-speech to probe SDM performance issues for time-varying phenomena.

Technical Contact  
Douglas Danforth, ARC, (415) 604-4998



## Discrete Speech Recognition Frequency Distribution

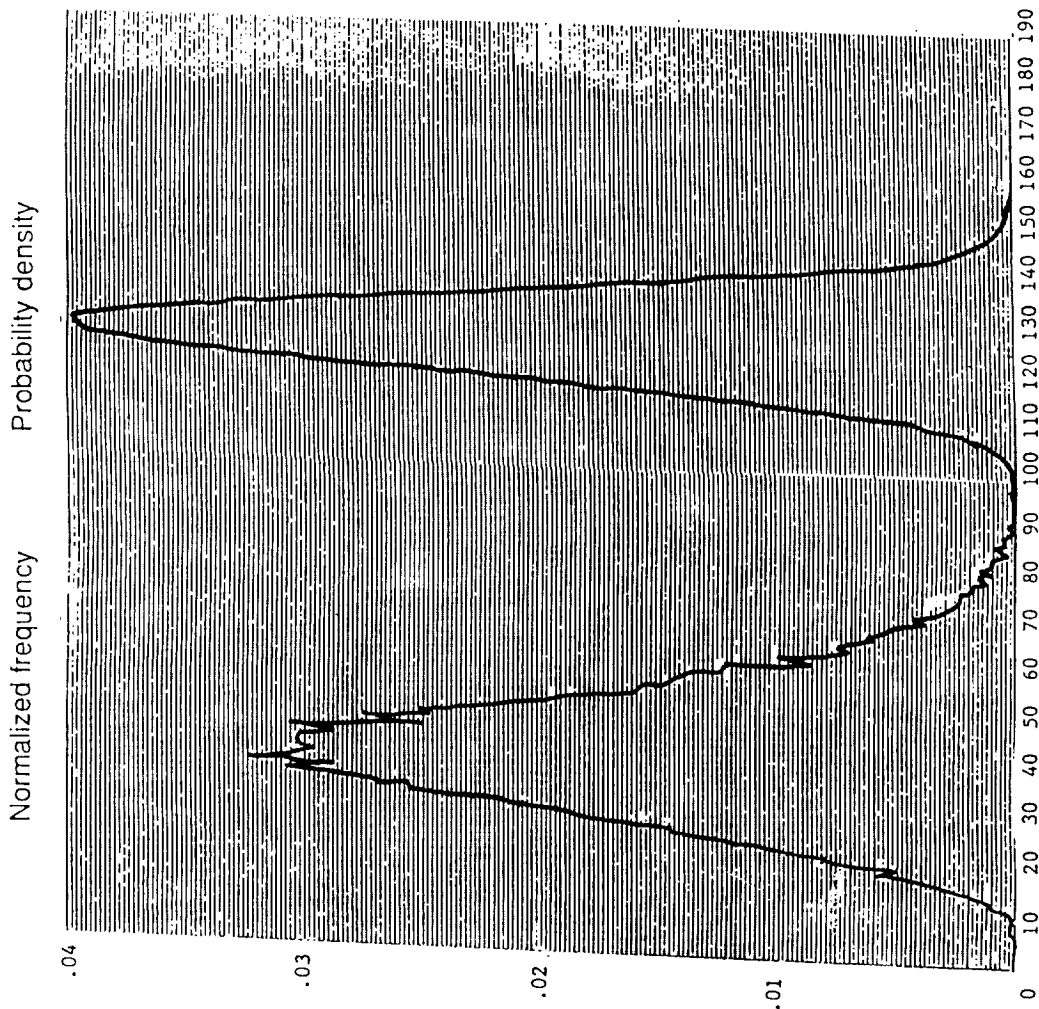

The curve on the left is the within-class distribution of digits. For example, various utterances of the digit "1" were encoded as binary patterns and compared to each other in terms of Hamming distance; then the frequency as a function of Hamming distance was tabulated. Similar tabulations for the other digits were pooled, with the results illustrated by the curve on the left. The binomial distribution on the right illustrates the expected frequency if the digits were randomly distributed in accord with the assumptions of the basic SDM model. The means are separated by 11 standard deviations.

## Formal Verification of a Fault-Tolerant Clock Synchronization Algorithm

---

The objective of this program is to perform a mechanically assisted formal verification of a fault-tolerant clock synchronization algorithm.

The reliability of a fault-tolerant computer system depends critically upon adequate synchronization between its redundant processors. It is important that the synchronization algorithm maintain proper synchronization of the good clocks even in the presence of other faulty clocks. Currently, ad-hoc techniques are used to develop the synchronization system of a fault-tolerant system. Unfortunately, synchronization systems can appear to be sound under a careful Failure Modes and Effect Analysis (FMEA) yet be susceptible to subtle failures. This work provides a formal mathematical basis for an existing algorithm.

The algorithm was defined using the Extended Special Language, which is based on typed, first-order predicate calculus extended to include higher-order constructs and lambda expressions. Using the EHDM (Enhanced Hierarchical Design Methodology) (mechanical) theorem-proving system, it was proved that the algorithm maintains the clocks within a bounded skew.

The Interactive Convergence Clock Synchronization Algorithm was verified. The formal verification process discovered several flaws in the original informal proof of the algorithm, even through the published data were unusually precise and detailed. The theorem was modified and successfully verified.

The performance theorem originally published was found to be flawed. These flaws were not discovered by the informal peer scrutiny to which the paper has been subjected since its publication. Clock synchronization algorithms are extremely important components of a fault-tolerant system yet are surprisingly easy to verify. This project provides another illustration of the increasing capabilities of formal verification methods. The clock synchronization problem is an asynchronous system that historically has posed difficulties for the formal methods approach.

The clock synchronization algorithm will be implemented in hardware and software. The correctness of the detailed design will be formally verified.

### Technical Contact

Ricky W. Butler, LaRC, (804) 864-6198

John Rushby and Frieder von Henke, SRI International

# Formally Verified Fault-Tolerant Clock Synchronization

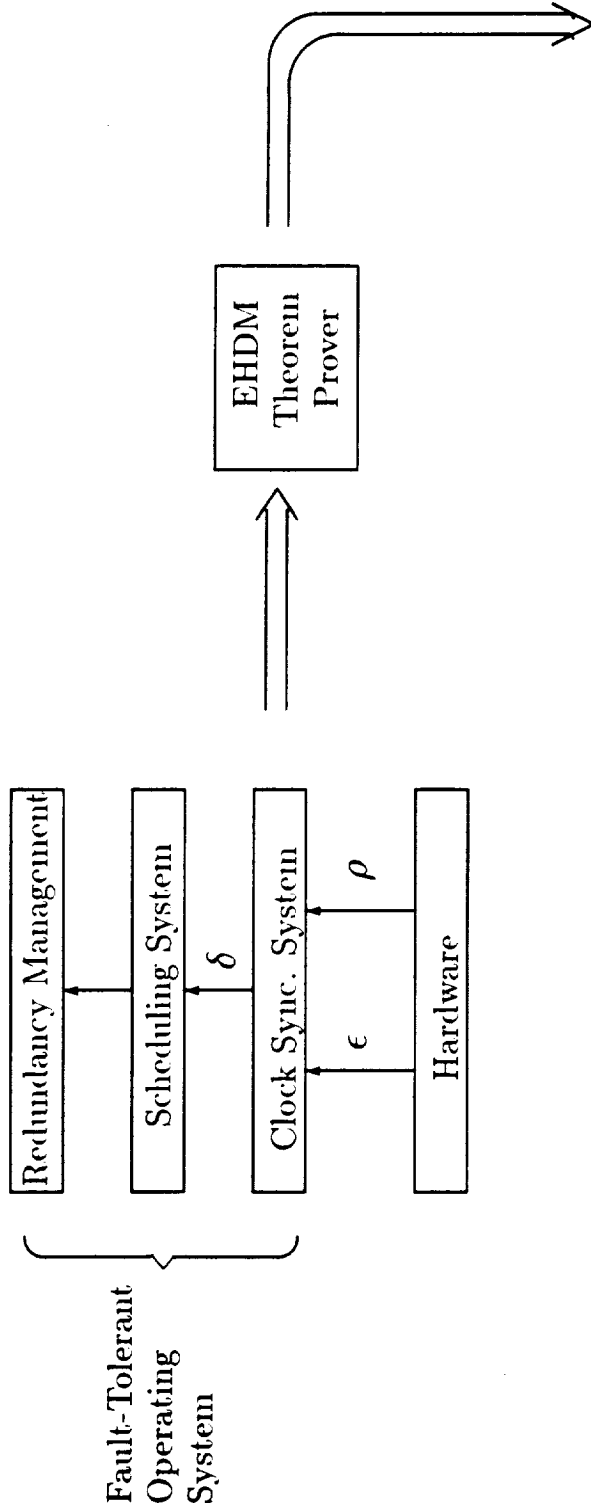

Proofs relating  $\delta$  to  $\epsilon$  and  $\rho$ :

- $\delta$  = clock skew bound
- $\epsilon$  = clock read error bound
- $\rho$  = clock drift rate bound

**lemma2a: Lemma**

$$\text{nonfaulty}(p, i + 1) \wedge |i| + \phi \leq R - S \wedge |i| \leq R - S \wedge T \in S^{(i)}$$

$$\supset |c_p^{(i)}(T + \phi + \Pi) - (c_p^{(i)}(T + \phi) + \Pi)| < \frac{\rho}{2} \times |i|$$

**lemma2b: Lemma**

$$\text{nonfaulty}(p, i + 1) \wedge |i| \leq S \wedge |i| \leq S \wedge T \in S^{(i)}$$

$$\supset |c_p^{(i)}(T + \phi + \Pi) - (c_p^{(i)}(T + \phi) + \Pi)| < \frac{\rho}{2} \times |i|$$

**lemma31A: Lemma**

$$SIC(p, q, i) \wedge \text{nonfaulty}(p, i + 1) \wedge \text{nonfaulty}(q, i + 1) \wedge$$

$$\supset |c_p^{(i)}(T^{(i+1)}) + \Delta_p^{(i)} - c_q^{(i)}(T^{(i+1)}) + \Delta_q^{(i)}|$$

$$\leq ((\delta + 2 \cdot \Delta) \cdot m + 2 \cdot (\rho \cdot S + r + \frac{\rho}{2} \times \Delta)) \cdot (n - m) / n$$

## Mapping Unstructured Grids to Hypercubes

---

The purpose of this research is to significantly increase the throughput for solving unstructured grid problems on massively parallel computers by reducing the communication time. Current focus is on the Connection Machine (CM).

We have developed a highly parallel graph-embedding technique and implemented it on the CM-2. It enables one to efficiently solve unstructured grid problems on massively parallel computers with regular interconnection topologies. The graph of the irregular problem is embedded into the graph representing the interconnection topology of the computer so that communicating processes are assigned to nearby processors.

Many implicit and explicit methods for solving discretized

partial differential equations require each point in the discretization to exchange data with its neighboring points every time-step or iteration. Thinking Machines Corporation has recently developed a new software package that reduces the time for general communication by a factor of 2 to 5. This mapping further reduces the communication time by a factor of 3.

Future activities include implementing a CFD application on the CM-2 for comparison with a similar application on the Cray YMP.

Point of Contact

Steven Hammond, ARC (RIACS), (415) 604-3962

# Map Irregular Problem to Regular Interconnection Topology

---

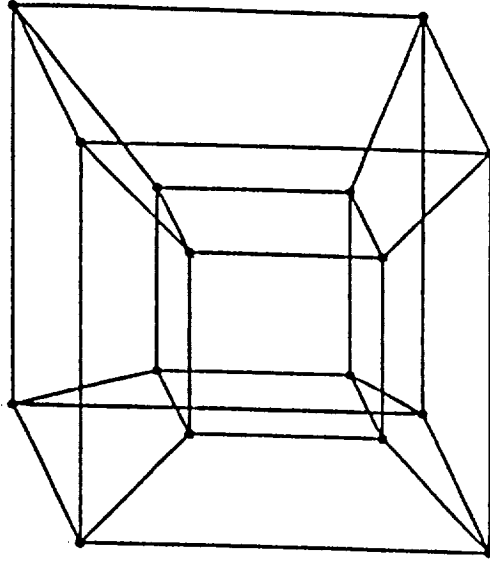
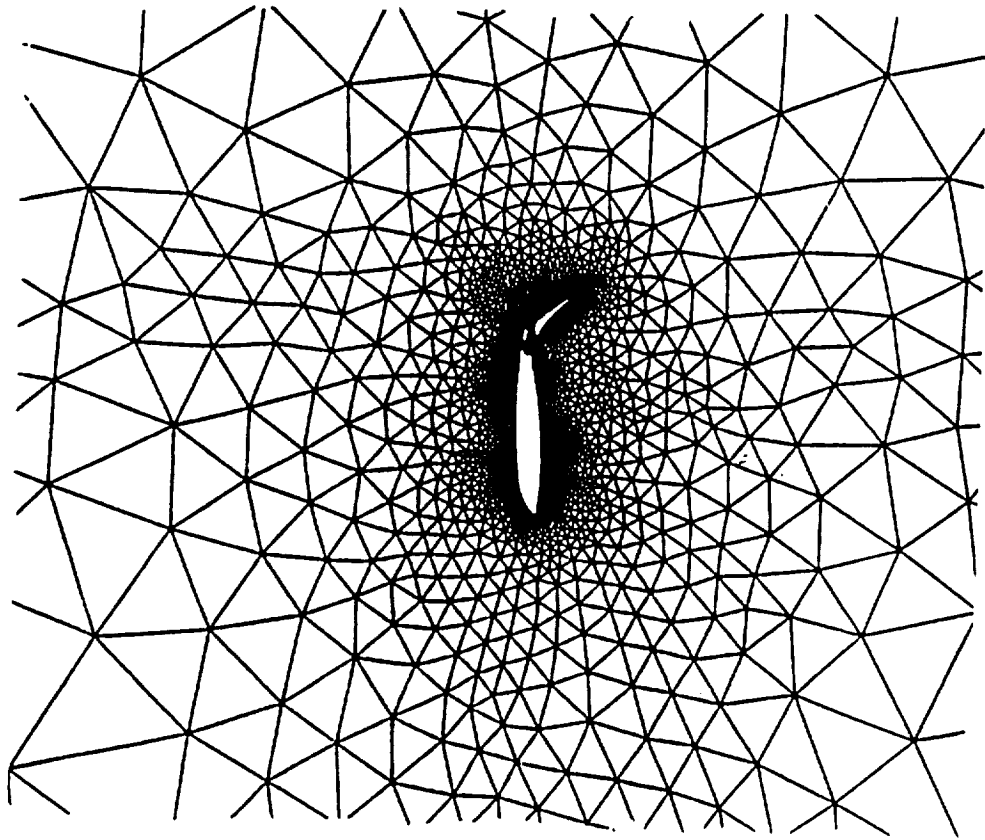

*4-Dimensional Hypercube*

## Performance Characterization of Machine Architecture

---

The main objective of this project is to develop a new methodology for the evaluation of different machine architectures and implementations. The idea is to construct a model of a machine based on its execution time for source language program constructs. Separately, one analyzes relevant source codes; by combining the analyses, one can evaluate the performance of any analyzed machine for any analyzed workload. Our efforts have been directed toward experimental methods for accurate machine characterization (the machine model), methods to maximize the accuracy of our performance predictions, and the use of the machine characterizations to analyze implementations and architectures.

Our research has produced a number of significant results:

- (a) Our methodology permits the evaluation of CPU performance with far less benchmarking effort than was previously needed. (b) Using our methodology, one can see why the observed performance occurs. Strong and weak points of various implementations can be determined and evaluated. (c) The variability of performance observed between two machines when run on a variety of benchmarks can be predicted and explained. (d) The sensitivity of a given machine's performance to variations on the workload can be explained and predicted. (e) The effect of improvements in machine performance can be predicted. (f) Our techniques can be used to characterize workloads.

The present status of this project is as follows: (1) We have developed a machine performance model consisting of 113 parameters which have been measured on a large set of machines ranging from supercomputers to high-performance workstations. (2) A large set of applications have

been characterized; these include the SPEC and Perfect Club benchmarks. Our results show the strength and weaknesses of these programs, and our methodology will help in the development of more representative benchmark workloads. (3) We have used the machine and program characterizations to validate our model by making execution time predictions and comparing these results with actual measurements. Very good accuracy has been observed. (4) We have investigated how our model can be used to compare the differences and similarities of machines and programs; we have proposed a set of metrics and have presented the results in reports and papers. (5) We are developing a set of experiments to characterize compiler optimization, and we are currently extending our execution time model to include the effect of optimizing compilers. (6) We have used our model to estimate the potential performance of the NEC SX-3 with respect to the performance of the NEC SX-2 and CRAY Y-MP/8128.

We plan to continue this project with the activities described above as "in progress," and by extending our model to include vector operations. A new machine characterizer will include a large number of experiments that will measure the performance of vector operations. In addition, we will extend our execution time model to produce approximate execution times for programs that use vector operations. We are investigating the applicability of vector performance prediction models to complement our scalar execution time prediction method.

Technical Contact

Alan J. Smith, ARC, (415) 642-5290

# Performance Characterization of Machines

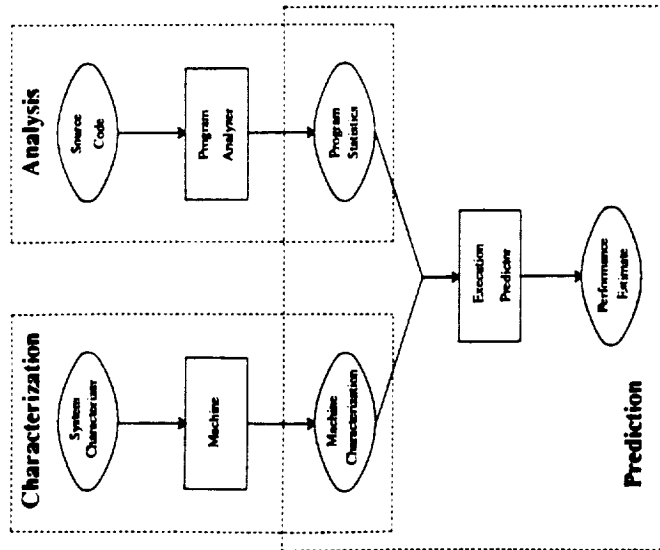

- Characterization of machines  
 Fortran abstract machine model  
 Model with 113 parameters  
 Experimental measurement of parameters  
 Thirty-five systems characterized
- Characterization of programs  
 Source code analyzer  
 Static and dynamic analysis  
 SPEC and Perfect Club benchmarks analyzed
- Execution time prediction of applications  
 Predictions for 16 machines and 25 programs  
 56% of the predictions have less than 10% error  
 88% of the predictions have less than 20% error

Performance Shapes of Reduced Parameters

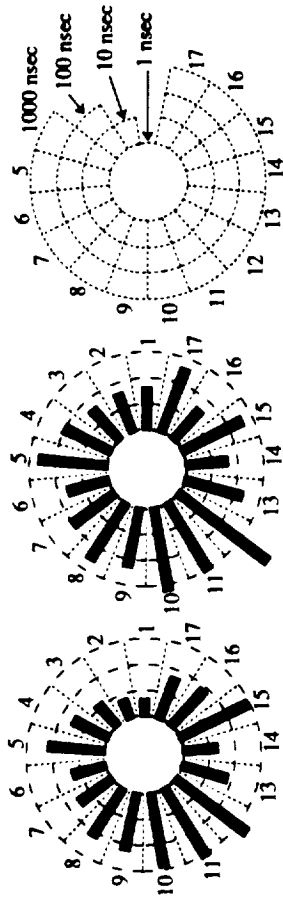

NEC SX-2 CRAY Y-MP/8128 CRAY X-MP/48

Execution Time Prediction

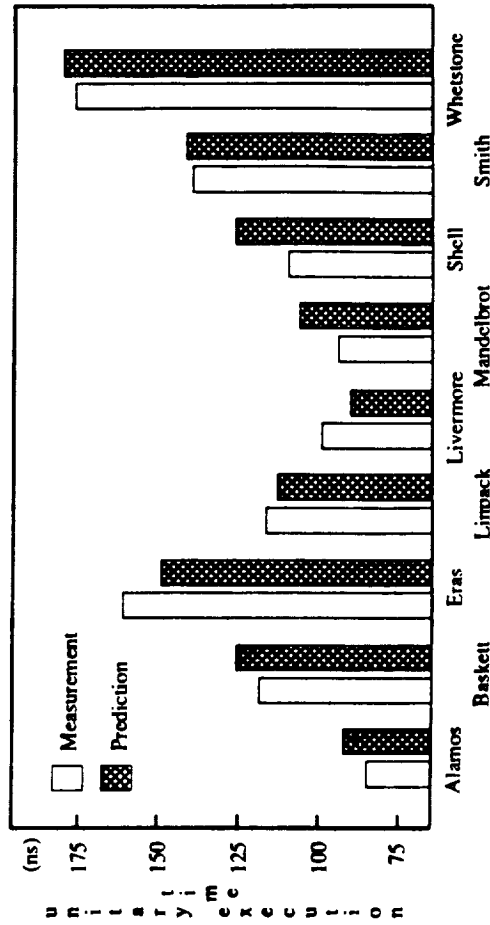

CRAY X-MP/48

## Performance Evaluation of an Implicit CFD Algorithm on a MIMD Hypercube

---

The objective of this program is to evaluate the performance of an implicit computational fluid dynamics (CFD) algorithm on a distributed-memory, multiple instruction stream, multiple data stream (MIMD) architecture. We plan to implement the functionality of ARC2D (2-D Euler/Navier-Stokes) code on the 128-node Intel Touchstone Gamma prototype (commercially known as the Intel Personal Supercomputer, model 860 [iPSC/860]).

The algorithm has been successfully mapped to the Touchstone architecture, and considerable effort was put into optimizing the code for the machine. In spite of the current FORTRAN compiler's inability to exploit pipelined arithmetic units on the i860 chip, overall performance and multiprocessor efficiencies appear promising. Current performance levels are below that of the single processor Cray Y-MP, but they are comparable to that of the Cray-2 and the Connection Machine (CM-2). The inadequate bandwidth of the data path to the node memory and of the internode communication network will continue to pose problems for implicit algorithms.

This work demonstrates that implicit CFD algorithms can be implemented on highly parallel distributed-memory MIMD architectures. It also identifies the architectural bottlenecks preventing the exploitation of the full performance potential of pipeline-reduced instruction set computing (RISC) chips. Removal of these bottlenecks will result in implementations of implicit CFD codes being implemented with sustained high performance and good scalability.

The ARC2D study will be completed by documenting the implementation details and results in a formal publication. Implementation of a 3-D implicit Navier-Stokes code (F3D) is currently under way. Issues related to the exploitation of functional parallelism, in addition to the data parallelism present in multiple overlapping grid applications, will be explored. The possibility of using implicit algorithms more suited for parallel processing with stronger convergence rates will be investigated as an alternative to the approximate factorization method.

Technical Contact

Sisira Weeratunga, ARC, (415) 604-3963



# Comparison of ARC2D Performance

Problem Size		NAVIER-STOKES CODE											
		Intel Touchstone		Cray-2		Cray Y-MP		Cray-2		Cray Y-MP			
		1	2	4	8	16	32	64	0.15	0.08	0.13	0.15	0.07
(192X64)	Sec./step	4.1	2.1	1.11	0.61	0.35	0.22	0.14	0.15	0.08	0.13	0.15	0.07
	MFLOPS	3.0	5.9	11.2	20.3	35.6	56.7	86.4	82	163	161	82	158
	Efficiency(%)	-	98	92	83	73	58	44	-	-	-	-	-
(256x80)	Sec./step	-	3.49	1.82	0.98	0.54	0.33	0.20	0.26	0.13	0.20	0.26	0.13
	MFLOPS	-	6.0	11.4	21	39	64	101.	79	161	101.	79	161
	Efficiency(%)	-	99	95	88	81	67	53	-	-	-	-	-
(320x128)	Sec./step	-	-	3.62	1.90	1.02	0.57	0.34	0.48	0.24	0.34	0.48	0.24
	MFLOPS	-	-	11.6	22	41	73	123	86	172	123	86	172
	Efficiency(%)	-	-	97	92	85	76	64	-	-	-	-	-
Problem Size		EULER CODE											
		Intel Touchstone		Cray-2		Cray Y-MP		Cray-2		Cray Y-MP			
		1	2	4	8	16	32	64	0.14	0.07	0.13	0.14	0.07
(192X64)	Sec./step	3.58	1.87	1.00	0.55	0.32	0.20	0.13	0.14	0.07	0.13	0.14	0.07
	MFLOPS	3.0	5.8	10.8	19.7	33.8	54.2	83.3	75	158	83.3	75	158
	Efficiency(%)	-	96	90	81	70	56	43	-	-	-	-	-
(256X80)	Sec./step	-	3.12	1.64	0.88	0.49	0.30	0.19	0.26	0.13	0.19	0.26	0.13
	MFLOPS	-	5.8	11.1	20.6	37.0	60.5	95.5	74	158	95.5	74	158
	Efficiency(%)	-	96	93	86	77	63	50	-	-	-	-	-
(320x128)	Sec./step	-	-	3.62	1.90	1.02	0.57	0.34	0.48	0.24	0.34	0.48	0.24
	MFLOPS	-	-	11.6	22	41	73	123	86	172	123	86	172
	Efficiency(%)	-	-	97	92	85	76	64	-	-	-	-	-

MFLOPS based on measurements using the Cray hardware performance monitor (hpm).  
Efficiency (%) = (( MFLOPS on one processor ) / N x ( MFLOPS on N processors )) \* 100.

## Two-Dimensional Shape Recognition Using SDM

---

The focus of this research was to test Sparse Distributed Memory (SDM) for recognizing two-dimensional shapes, using Andrew B. Watson's cortex transform for preprocessing.

A total of 280 random characters were selected from the US Postal Service Database of Handwritten Zip Codes as standard shapes. Half the characters were used to train the memory and half were used for testing. The test results can be compared with results of other groups using the USPS data base.

A preliminary study revealed that the low-pass filter of the cortex transform was suitable for an input representation for SDM. Accordingly, each character was scanned into an 8 X 8 black-white pixel array and filtered, yielding a four-bit gray-scale representation encoded as a 256-bit

binary pattern. After training the memory on half the characters, the SDM correctly labeled 86% of the test characters.

The method is very general inasmuch as no special features of written characters were used to improve performance. And it is fast — training requires less than 2 minutes. A system designed for character recognition at Bell Laboratories performed in a comparable measure at 88% correct but used hours of run-time for training.

Future plans are to continue investigating encoding methods, e.g., a very general contour map representation of two-dimensional shapes suggested by Kanerva.

Technical Contact  
Pentti Kanerva, ARC (RIACS), (415) 604-4996

# The Cortex Transform

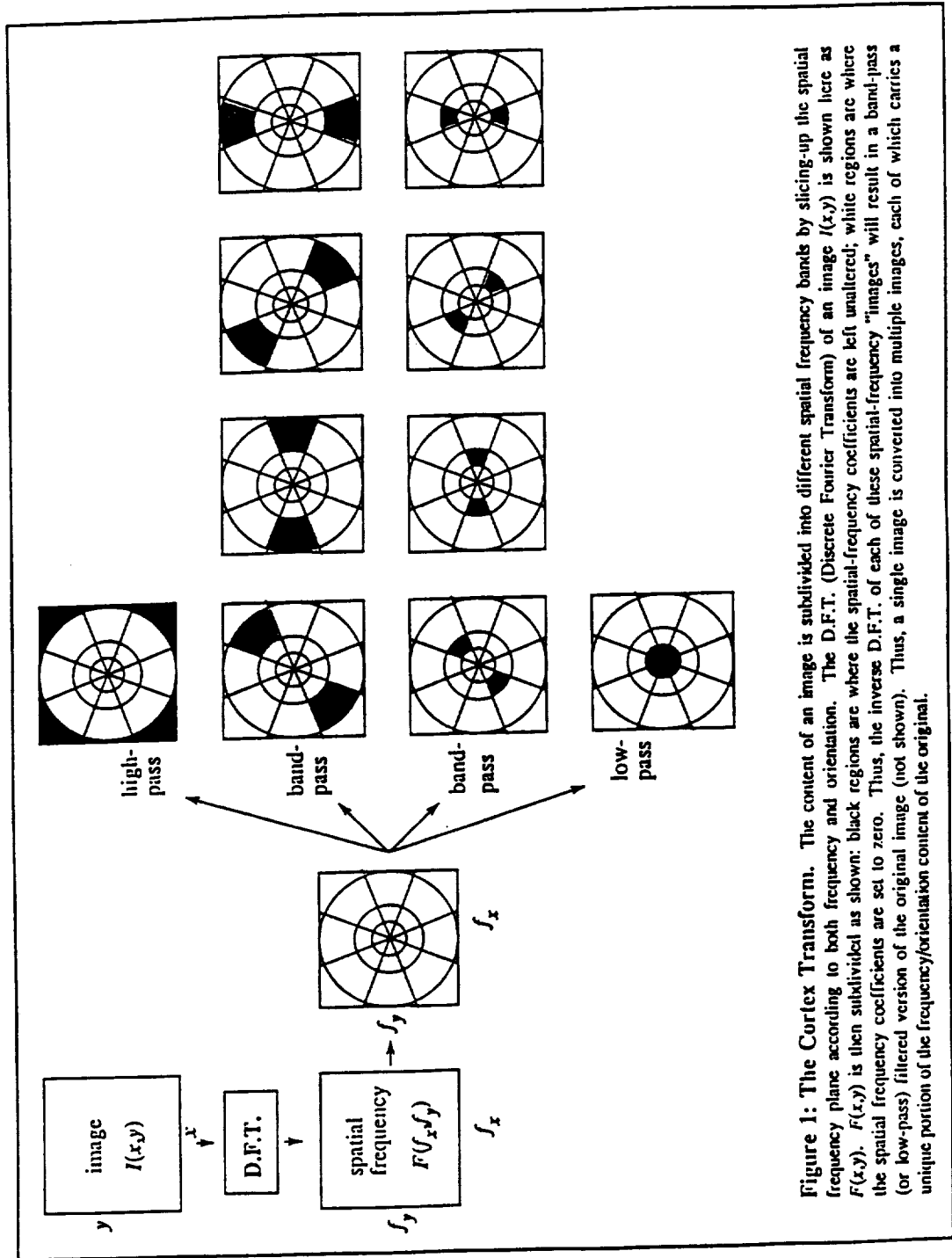

**Figure 1: The Cortex Transform.** The content of an image is subdivided into different spatial frequency bands by slicing-up the spatial frequency plane according to both frequency and orientation. The D.F.T. (Discrete Fourier Transform) of an image  $I(x,y)$  is shown here as  $F(f_x, f_y)$ .  $F(f_x, f_y)$  is then subdivided as shown: black regions are where the spatial-frequency coefficients are set to zero. Thus, the inverse D.F.T. of each of these spatial-frequency "images" will result in a band-pass (or low-pass) filtered version of the original image (not shown). Thus, a single image is converted into multiple images, each of which carries a unique portion of the frequency/orientation content of the original.

## Software Management Environment

---

The Software Management Environment (SME) is a software tool designed to assist a manager in monitoring, analyzing, and controlling an ongoing software project. The SME's major functions include tracking software project parameters; analyzing the differences between the current project's development patterns and the expected development patterns within the application environment; predicting characteristics such as milestones, cost, and reliability; assessing the overall quality of the project's development process; and providing advice and guidance on management of the software project. To provide these functions the tool continually examines available development data from the project of interest including manpower, software changes, computer utilization, and completed milestones and compares this information to data from past projects and to a model of the typical project.

During FY 1990, the SME has been extended and improved to include expert assessment of project problems and to model the project environment. With these extensions in place, the SME has been released for use by software managers within the Flight Dynamics Division at GSFC. By using the SME for ongoing software development projects within Flight Dynamics, the managers will be able to effectively compare, predict, and analyze key project parameters. This represents the first use of the SME on actual projects and will provide valuable insight into the accuracy and usefulness of the tool, as well as help to establish future research needs for the SME.

During the next year, the SME will be prepared for release to other organizations outside of Flight Dynamics. This

planned release will begin to establish the usefulness of such a tool in an environment beyond the one for which it was originally designed. Other planned research includes the development of an overall project assessment function and to begin examining ways of providing guidance to managers for solving development problems.

### Technical Contact

Jon Valett, GSFC, (301) 286-6564

# Management of Complex Software Projects

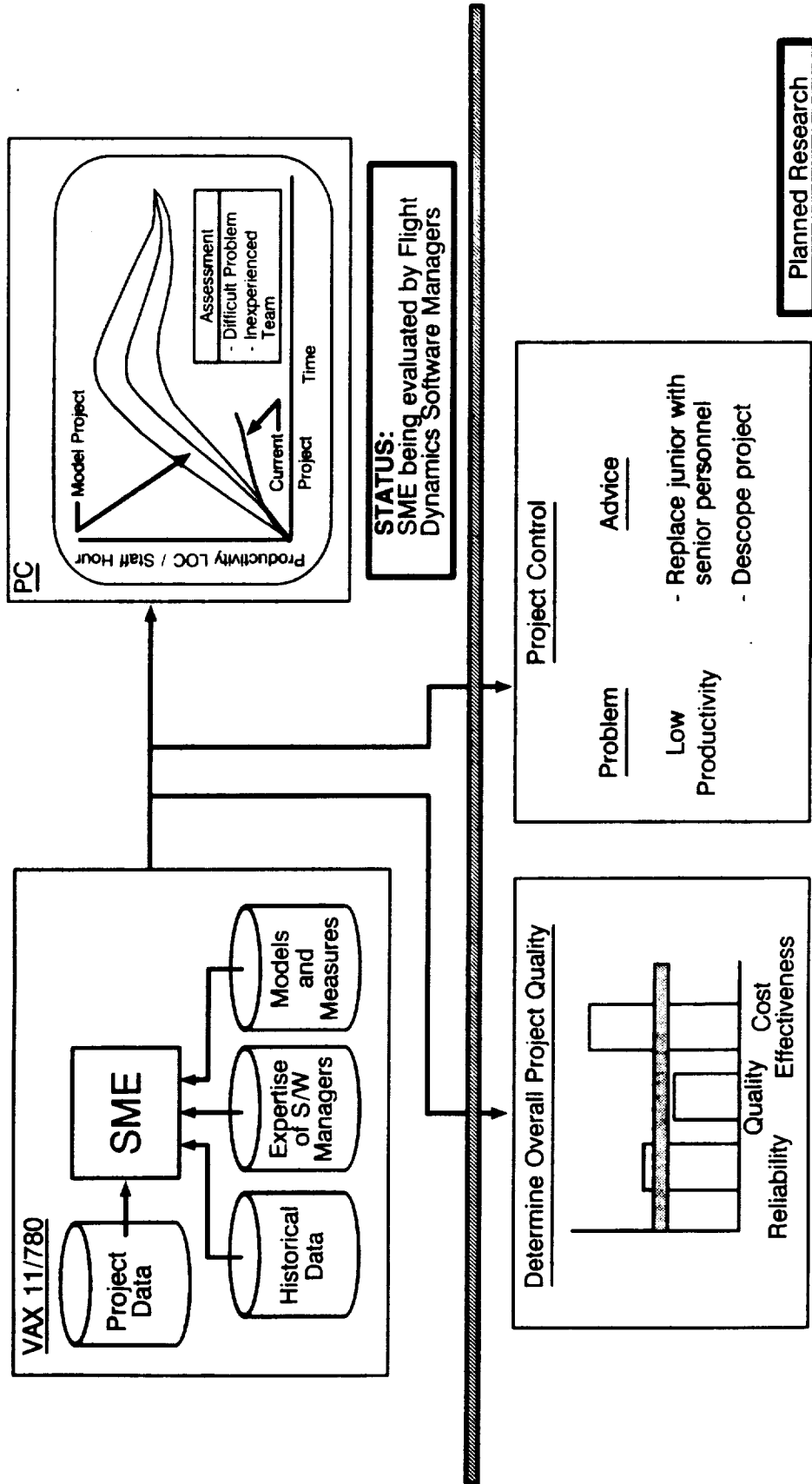

## Autonomous Exploration

---

Robotic and human exploration to the moon and Mars are anticipated in the coming decades. The robotic missions will serve to perform geological survey and surface characterization to collect samples and to return the necessary information about potential landing sites to enable safe and productive human missions. Vehicles for lunar and planetary exploration will carry complex scientific imaging instruments, including imaging spectrometers capable of collecting data points at several hundred wavelengths for each pixel. To exploit the full capabilities of these instruments, methods must be developed for real-time information extraction, multisensor fusion, and automated decision making to drive instrument reconfiguration. On-board interpretation of the data from a suite of instruments will be required for site characterization, for collecting samples, and for choosing desired traversal paths on a ground-roving vehicle.

The objectives of this task are to develop and implement autonomous, real-time methods of high-dimensional image data reduction, information extraction, and goal-driven decision making. Data from multiple instruments may be fused to provide a more complete interpretation of a scene. A hierarchical, multiresolution approach in both spectral and spatial domains reduces computational requirements by concentrating the analysis on image areas that prove potentially interesting during initial, low-computation analysis. This approach includes iterative cycles of data acquisition and interpretation, decision making, and instrument reconfiguration.

The working system analyzes both single band imagery (to extract shape and textural information) and multispectral images (to determine geologic composition). The spectral classification steps, performed on simulated neural networks, include assessing classification accuracy so that poorly classified or unknown mineral classes may be handled appropriately. The system has been designed so that at each step in the hierarchical analysis procedure, information from other instruments may be incorporated if available. All available data are used to decide whether to continue examining a region and with what instruments. The system is capable of specifying the spectral bands of importance for the next step in the analysis, so that the imaging spectrometer may be automatically reconfigured.

Although the existing design is primarily aimed at supporting autonomous robotic exploration, many elements will transfer readily to support systems for human exploration. In particular, the analysis and interpretation of multiple complex data sets will still be performed by machine during human exploratory missions. Further development of the existing data analysis system will enable the collection and interpretation of instrument data to provide human explorers with information in a form that will allow them to perform most effectively.

### Technical Contact

Susan J. Eberlein, JPL, (818) 354-6467

Jerry E. Solomon, JPL, (818) 354-2722

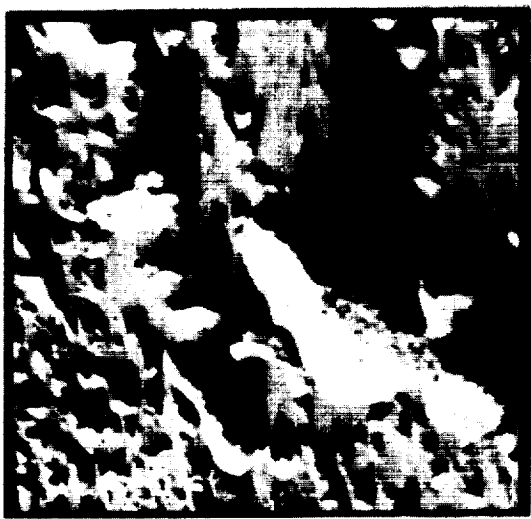

# Autonomous Exploration

Automated Spatial Segmentation



Hierarchical Spectral Analysis



CLASS	COLOR
Inosilicates, Sorosilicates, Carbonates	
Phyllosilicates, Borates, Sulfates, Phosphates	

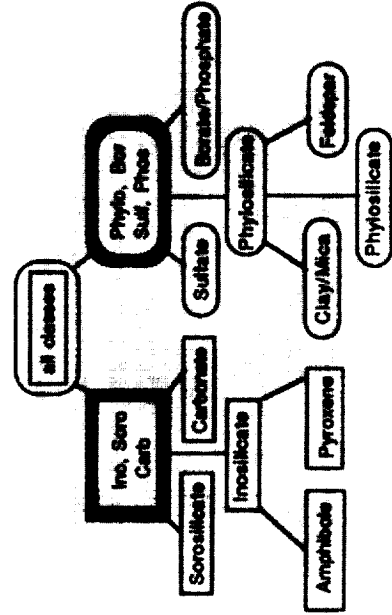

## Application and Assessment of Industry-Standard Guidelines for the Validation of Avionics Software

---

The objective of this program is to incorporate industry standards for the development of real-time software into an experimental testbed for studying the failure process of avionics software and assess the effectiveness of methods that comply with those standards.

Verification activities were defined along with configuration management and software quality assurance policies for the development of Guidance and Control Software (GCS) in accordance with the FAA Radio Technical Commission for Aeronautics RTCA/DO-178A guidelines for the certification of avionics software. These verification procedures were applied in the generation and testing of three independent versions of the GCS code. All software error data needed to assess the effectiveness of software development and verification methods and provide the basis for software reliability model development were collected.

Verification and validation activities in accordance with the DO-178A standards for avionics software have been defined and implemented in the development process of the GCS versions. Software error data are being collected throughout the development cycle.

Although many software reliability experiments have been conducted, these experiments have not considered complex avionics software that is critical to mission success. The GCS experiment provides a realistic baseline for investigating the failure behavior of avionics software. Employing the DO-178A guidelines will yield error data from real-time software developed according to industry standards,

and the integrity of the error data along with the ability to reproduce it are guaranteed by the implementation of the verification plan. Since adequate models for dependable estimation of software reliability do not currently exist, the error data from the GCS experiment will provide an indispensable basis for improving software reliability models. This experiment further establishes a pragmatic baseline for investigating the effectiveness of development methods, such as those prescribed by the FAA, for avionics software.

The next steps in this program are to complete testing of the three GCS versions and analysis of the resulting software error data and develop more precise software reliability models and more effective software development procedures based on this information.

### Technical Contact

Kelly J. Hayburst, LaRC, (804) 864-6215

Anita M. Shagnea, Research Triangle Institute



# Production of Realistic Software Error Data

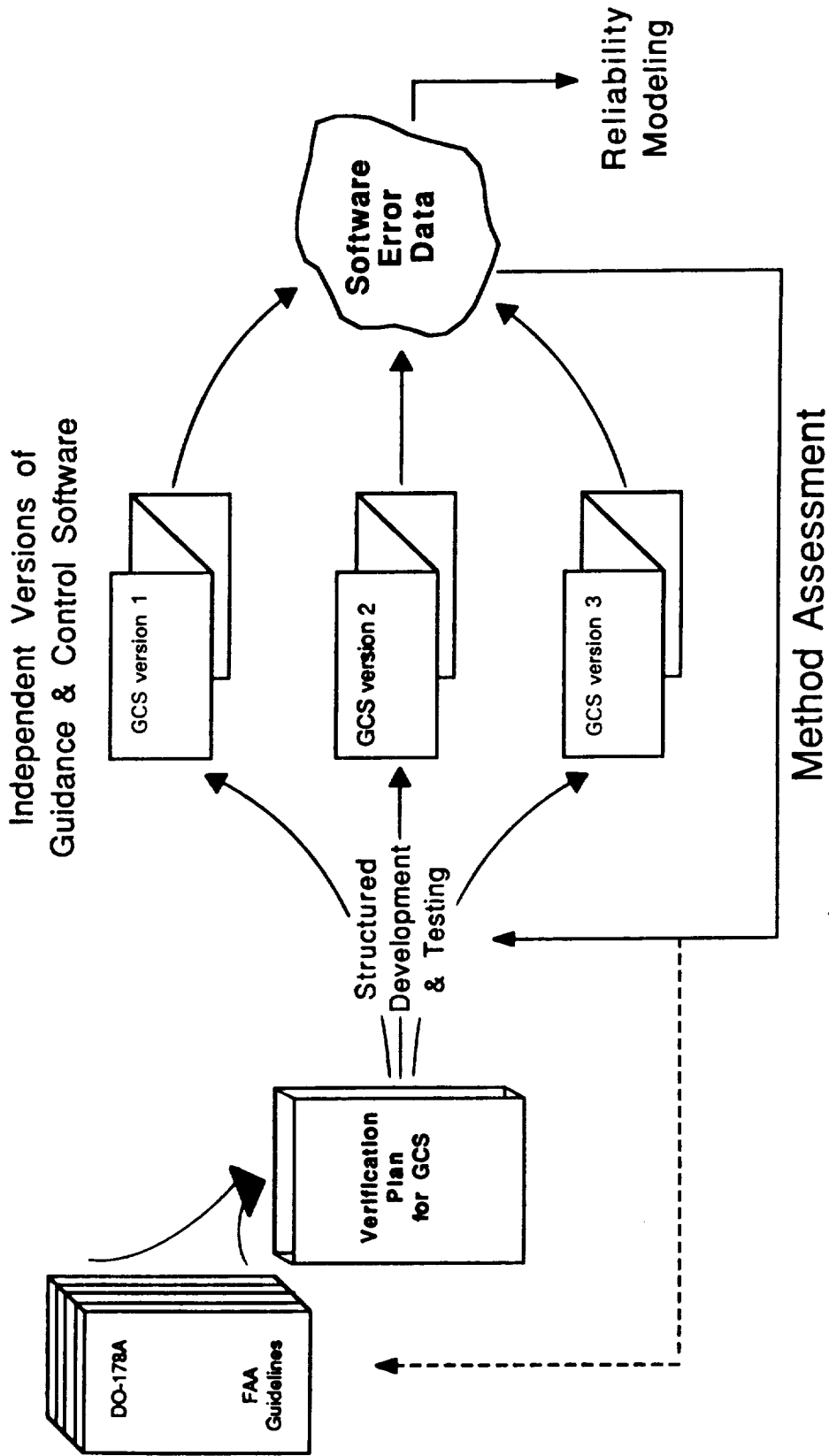

## Automatic Generation of ADA Code

The objective of this program is to demonstrate and assess the ability of the Charles Stark Draper Laboratory (CSDL) Computer-Aided Software Engineering (CASE) system to generate ADA flight control code. The Advanced Launch System (ALS) Advanced Development Program is sponsoring the development of a Computer-Aided Software Engineering (CASE) tool by the Charles Stark Draper Laboratory that could dramatically improve the software development process and reduce production and maintenance costs. As a demonstration of this tool, the flight control system software of the Boeing 737 autopilot autoland was produced using the ALS CASE system.

ADA source code and specification documentation were automatically generated with the ALS CASE system. The specifications for the autoland design were reverse-engineered from inspections of FORTRAN flowcharts and source code. The software requirements were interactively specified in the form of hierarchical engineering block diagrams via the system's highly flexible, graphic interface. The requirements defined by these diagrams were checked for data type consistencies by the CASE system and captured in a centralized knowledge base. The knowledge base was then used to automatically produce executable code and a formatted requirements document. A test methodology was developed which maximized coverage but minimized the number of tests. Duplicate tests were run on both the FORTRAN and ADA code and then the results compared. Open and closed loop tests uncovered 11 discrepancies. Nine of these errors were attributed to mistakes in the entry of the specifications into ALS CASE (human errors, analogous to programming errors). Two errors were traced to the FORTRAN code. No errors were

traced to the ALS CASE system.

The development and testing of "real" software applications, such as the autopilot autoland, will lend much to the credibility of the ALS CASE system. In addition to the two errors found in the FORTRAN code, several ambiguities and inconsistencies were discovered in the specification as a result of using the ALS CASE diagram methodology. ALS CASE has the potential to significantly increase the reliability of the generated code by (1) checking for inconsistencies, ambiguities, and completeness of the specification; (2) allowing the user to specify software using engineering notation and block diagrams that are familiar; (3) automatically performing the usually error-prone transformation to ADA code; and (4) supporting reuse of code. The ALS CASE effort has demonstrated the feasibility of a knowledge-based approach to software development and has identified areas that warrant research to further automate the software development process.

Progress is being made to enhance the ALS CASE system in a number of areas. These include a software design methodology interface, an automated testing facility, and project management capabilities. As a further demonstration, the guidance and control software for the final decent phase of a planetary lander is being generated using the ALS CASE system. This code will be used in a software error-data gathering experiment to be conducted by Langley and the Research Triangle Institute.

Technical Contact

Carrie K. Walker, LaRC, (804) 864-1704

John J. Turkovick, LaRC, (804) 864-1704

# ALS Case System

## *Conventional Approach*

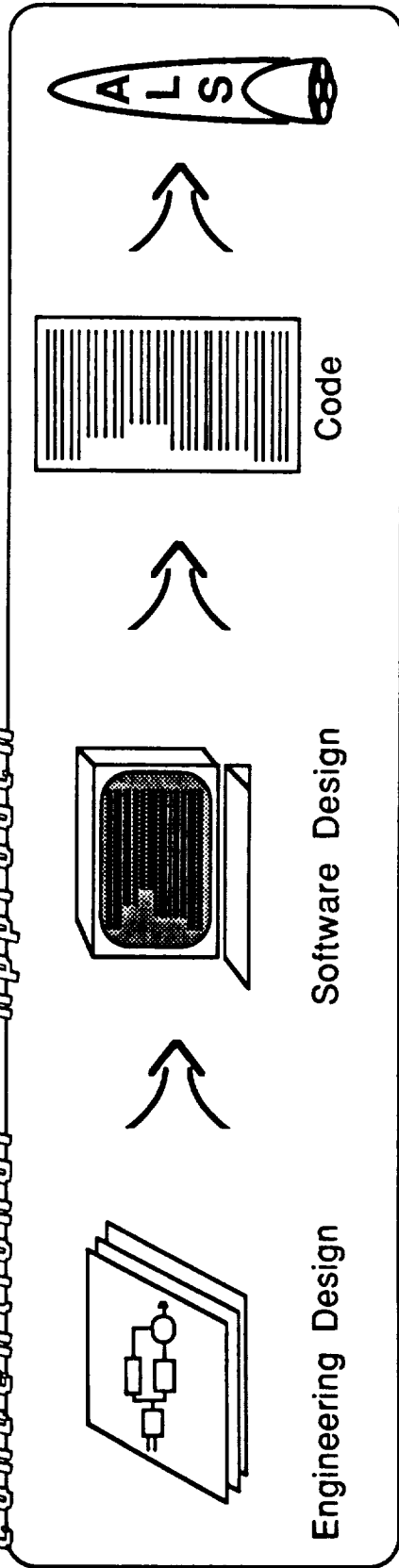

## *ALS CASE*

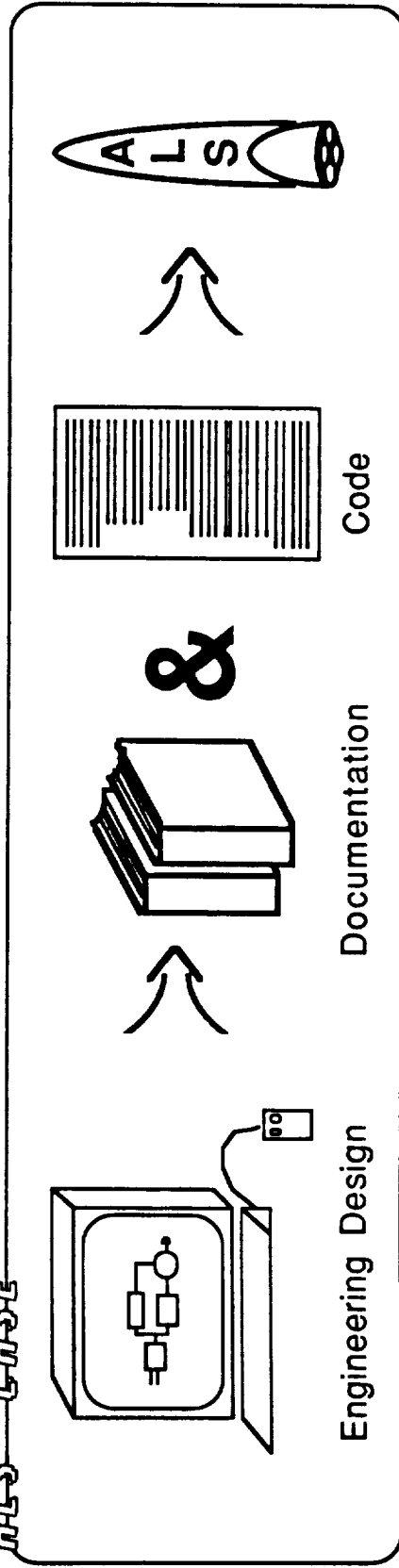



## **Controls and Guidance – Aeronautics**

The overall objective of the Aeronautics Controls and Guidance Program is to provide a validated technology base leading to the development and exploitation of new concepts, analysis/design methodologies, and flight systems for future civil and military aircraft. This technology base will provide increased efficiency, effectiveness, reliability, and safety for new aircraft. The program is organized in broadly applicable, generic elements and in more focused vehicle-specific elements. The generic elements are Control Theory, Guidance Technology, and Flight Crucial Systems. Vehicle-specific elements are Generic Hypersonics, Subsonic Transport/Commuter/General Aviation, Rotorcraft, and Fighter/Attack.

Research in the Control Theory element is directed toward the development of improved flight control analysis/design methodologies for highly integrated, robust flight control systems. These methodologies will account for strongly coupled, nonlinear plant dynamics. In order to develop an understanding of the dynamics of new vehicles, such as VSTOL and High Alpha research vehicles, system and parameter identification methods are being developed. New control approaches and concepts are exploiting emerging technologies such as artificial intelligence. Research in the Guidance Technology element involves the development of satellite precision navigation concepts and advanced technologies for wind shear detection and avoidance. Flight Crucial Systems research is directed toward the development of design, assessment, and validation methodologies for flight crucial systems. Increasing emphasis will be placed on developing engineering tools that support cost-effective certification of future fly-by-light systems in flight crucial applications.

Generic Hypersonics research is focused on development of multidisciplinary modeling methods, integrated aero/propulsion controls, handling qualities criteria, trajectory optimization for hypersonic vehicles, and instrumentation for both flight and ground testing. In the Subsonic Transport element, activities are directed toward technologies that will provide more efficient civil transport operations in the future National Airspace System. The development of efficient 4-D guidance/control systems leading to enhanced efficiency and capacity in the terminal area is a major thrust in this element. Technology developments in automated mission management and goal-directed flight path management leading to automated nap-of-the-earth flight capability are areas of emphasis in the Rotorcraft element. Research in the Fighter/Attack element is focused on advanced guidance and control concepts for future superagile aircraft, development of automated flight test techniques, and development of multidisciplinary design methodologies for highly interactive dynamic systems.

The Aeronautical Controls and Guidance Program involves analytical and experimental research performed by in-house, university, and industry personnel. Extensive use of ground-based simulation is a characteristic of the program, with selected flight experiments being conducted in a variety of aircraft. More emphasis is being placed on carrying the most promising concepts into flight evaluation and validation programs.

Program Manager: Ray V. Hood  
NASA/OAET/RC  
Washington, DC 20546  
(202) 453-2745

## Ames/Langley Joint Simulation: 4D Aircraft/ATC Operations Study

A real-time simulation was conducted to evaluate the effectiveness of the NASA Ames developed Center/TRACON Automation System (CTAS) in assisting controllers with the management of mixed traffic (4D equipped and unequipped aircraft) and the impact of CTAS on piloted 4D equipped aircraft operations. This ATC experiment is unique in that it was the first joint simulation involving both ARC and LaRC.

The focus of the experiment was to study the operational issues concerning the handling of 4D equipped aircraft in the arrival flow. The real-time ATC simulation facility at Ames was used to create the ATC environmental and traffic scenarios for the controller test subjects. The major components of the ATC simulation included: (1) the pseudopilot simulation, which generated and controlled the air traffic, and (2) the traffic management advisor (TMA) which provided the Center controllers with a variety of automation tools for the sequencing of traffic. The final approach spacing tool (FAST), which assists in TRACON operations, was employed in an auxiliary capacity to study the TRACON flows generated by the Center arrival activity. The LaRC TSRV 737 piloted simulator was used to introduce 4D traffic into the arrival flow. The ARC and LaRC facilities were connected via transcontinental voice and data links. This experiment employed six active Center controllers as test subjects, working in teams of two. The pilot subjects, used by LaRC for the TSRV, were current 737 captains from several major air carriers.

It was determined that the accommodation of a 4D aircraft

in the arrival flow requires careful coordination of procedures between the pilot and the controller. Otherwise, conflicts may develop that add to the controller's workload. Special emphasis was placed on the development of efficient, yet effective, procedures and phraseology for 4D operations. However, the experience of the simulation leads to the broad conclusion that a ground-to-air data link may be required for proper integration. Overall, the response from the controller subjects was favorable; they strongly encouraged the development and operational implementation of the ground-based automation tools. The controllers were quite enthusiastic about the 4D capabilities demonstrated by the TSRV and they appreciated how airborne 4D capabilities could improve the efficiency of air traffic control.

The simulation demonstrated the capability of the ATC Automation Laboratory to examine complex issues in the design of future ATC concepts. Results from this study have been presented at several technical meetings and seminars. Additional simulations are planned to further refine the automation tools and procedures as well as develop new capabilities such as a simulation of an air-to-ground data link and advanced 4D pseudoaircraft. The long term goal, however, is to prepare the automation tools for evaluation with live traffic.

Technical Contact  
Steven Green, ARC, (415) 604-5431

# Air Traffic Simulation

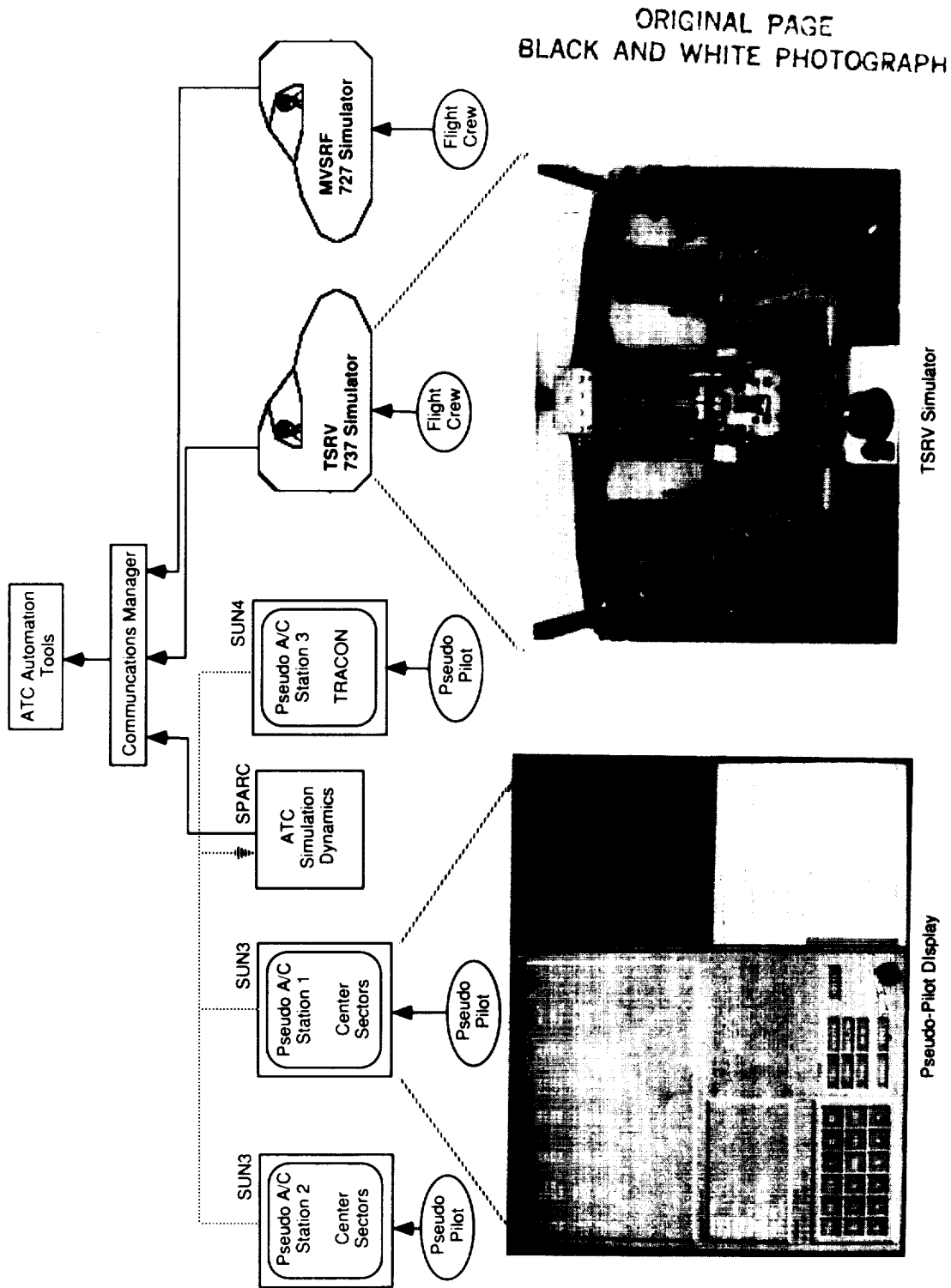

## Computer Aiding for Low Altitude Helicopter Flight Project

---

Helicopters that operate in threat areas have a need for low-level, maneuvering penetration capability for night-time and adverse weather conditions. Currently, low-level penetration is accomplished through the use of terrain following (TF) radars, forward-looking infrared (FLIR) systems, and night vision goggles (NVG). This combination is in place in the USAF Special Operations Forces (SOF) CH-53 Pave Low III aircraft and proposed for the U.S. Army's SOF aircraft. Though these systems provide a low-level penetration capability, the development of digital terrain maps, advanced navigation systems, and high speed on-board computer systems enable more effective terrain masking performance.

As an element the Automated Nap-of-the-Earth (ANOE) Program, a low-altitude guidance concept that takes advantage of knowledge of terrain to define a valley-seeking trajectory for improved low-level penetration performance has been developed. The basic algorithm and control/display designs have been developed and successfully tested in piloted simulations over the past few years. The last simulation, completed in January 1989, included Army, NASA, and Air Force Pilots, and has led to a Memorandum of Agreement (MOA) between NASA-Ames and the U.S. Army Avionics Research and Development Activity (AVRADA) for a joint flight experiment in the AVRADA UH-60 STAR helicopter.

In support of the flight evaluation two simulations have been scheduled on the NASA-Ames Vertical Motion Simulator. The first was initiated in June 1990 and will be a detailed operational evaluation of the algorithm using a

UH-60 aircraft model, a helmet mounted display, and a terrain model of the Carlisle Pennsylvania area which is the test area for actual flight test. Major research issues will include conversion of the display symbology from the head-up-display format to the helmet-mounted display and an evaluation of the effect of navigation errors on operational performance. The second simulation will include an interface with a replication of the flight computer and will be used to validate the flight software and develop the detailed flight test plan. The flight test is scheduled for August 1991.

### Technical Contact

Harry N. Swenson, ARC, (415) 604-5469



# Computer-Aided Low Altitude Helicopter Flight

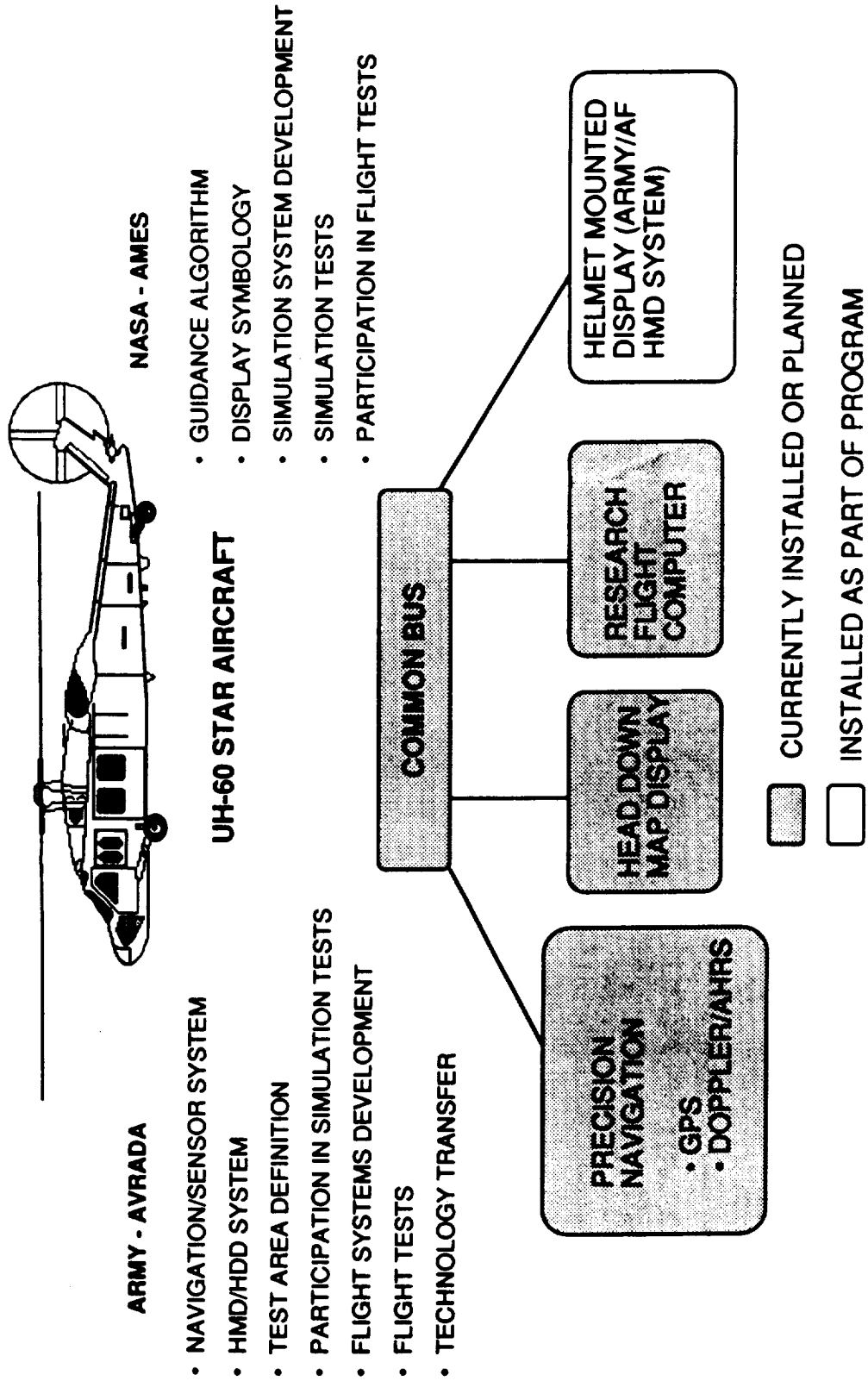

## Field-Based Passive Ranging Using Matched Velocity Filter

Helicopters in covert nap-of-the-earth operations require passive ranging for obstacle avoidance. A single or a stereo pair of visual or infrared forward-looking cameras can be used to produce a stream of images (per camera) called optical flow. The 3-dimensional location, particularly the range, of some chosen objects of all discernible points in the field of view can be recovered from the optical-flow imagery. Feature-based localization suffers from the need to identify objects between successive frames, whereas field-based methods operate on all pixels that are identified by their gray-level rather than by shape. Velocity filtering (VF) is a particular field-based method that has been used as a track-before-detect method for target detection. It is very efficient computationally because it is inherently parallelizable.

Accomplishments to date include doing the theoretical and performance analysis work for the VF method and developing the VF algorithm which has produced very encouraging results on real laboratory data. Last year, the algorithm was interfaced with the SUN workstation environment rather than functioning as a stand-alone program. This environment enables us to share the image data base — especially that obtained recently from a helicopter test flight, and also enables us to display data and results in a variety of ways using perspective views, false color, and animation methods.

It has been experimentally shown that the VF algorithm, like most other algorithms, has its own advantages and shortcomings. Our goal is to incorporate ideas and meth-

ods from fundamentally different types of algorithms so as to complement weaknesses of one by strengths of another. Work has been done in pixel region growth in order to average the algorithms results over more than one pixel at a time and thus increase its robustness.

Currently, the VF algorithm is being modified to improve and extend its performance and robustness. One of the important issues is extending the existing algorithm to operate on data from a maneuvering vehicle. In addition, theoretical work is in progress to determine the range accuracies obtainable from combined stereo/optical-flow passive ranging. A special emphasis is given to range accuracy degradation caused by non-perfect sensor/platform alignment.

Technical Contact  
Yair Barniv, ARC, (415) 604-5451

# Field-Based Passive Ranging Using Matched Velocity Filters

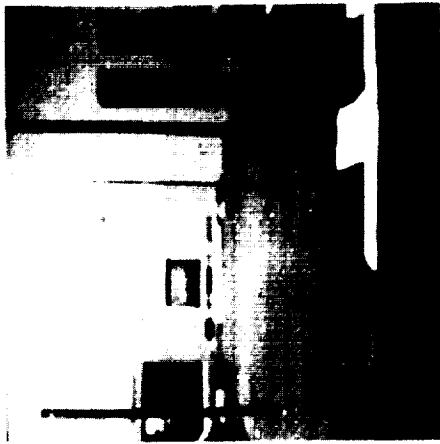
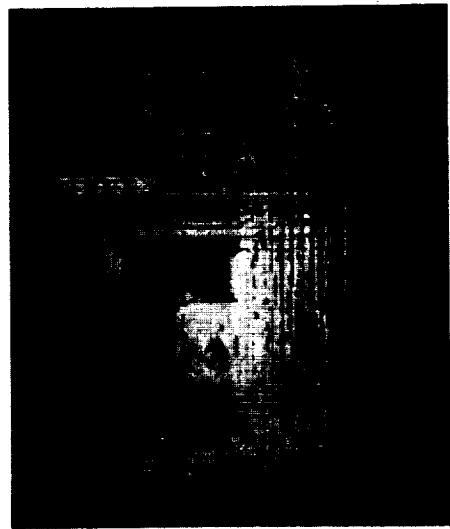

Image Sequence



Range Image

$$H(\bar{k}, \omega) = \frac{S^*(\bar{k}, \omega)}{N_0} \exp(-j\omega T)$$

$$h(\bar{r}, t) = F^{-1} [H(\bar{k}, \omega)]$$

$$I_c(\bar{r}, t) = \iiint I(\bar{\rho}, \tau) h(\bar{r} - \bar{\rho}, t - \tau) d\tau d\bar{\rho}$$

(shift and add)

Matched Filtering

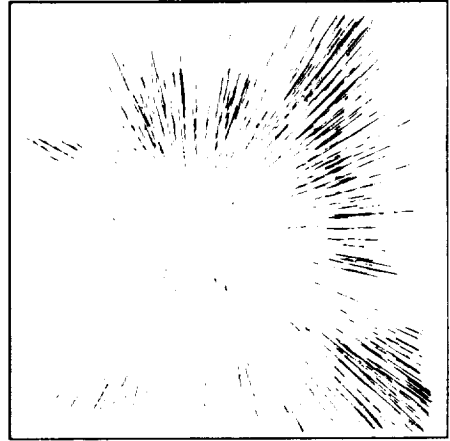

Optical Flow

ORIGINAL PAGE  
BLACK AND WHITE PHOTOGRAPH

ORIGINAL PAGE IS  
OF POOR QUALITY

## Final Approach Spacing Tool

The Final Approach Spacing Tool (FAST), an element of the integrated Center/TRACON Automation System (CTAS) designed at NASA-Ames, was evaluated by operational air traffic controllers in a real-time simulation. The simulation addressed the issues of interarrival spacing at the runway, airspace utilization, and controller acceptance.

The FAST system monitors each aircraft's current state (position, airspeed, and heading) and predicts arrival time based on the local TRACON's standard arrival operations, the controller's inputs, the aircraft's performance characteristics, and current weather conditions. Based on a conflict-free scheduled arrival time at the runway, an efficient path to the runway is synthesized using speed control, path stretching, and path modification. The suggested path and speed commands are displayed to the controller automatically or by using mouse-controlled functions through color graphic display.

All major components of FAST have been completed: (1) a trajectory synthesis algorithm that predicts aircraft arrival times based on aircraft performance and weather conditions; (2) an off-route vectoring advisory capability; (3) a rescheduling capability for arrival position shifts within the TRACON; (4) a missed approach and tower enroute advisory capability; (5) an interactive controller graphical interface; and (6) communications links and protocols to the traffic management advisor (TMA) and Center descent advisor (DA) controller displays.

A real-time simulation evaluation was conducted in January 1990. Operational controllers were fed runway

capacity-limited arrival rates for Instrument Flight Rules (IFR) conditions with a mix of heavy and large aircraft. The evaluation demonstrated that the automation achieved a decrease in interarrival spacing at the runway of 9 seconds. This translates to an increase in landing rate of 4.6 aircraft per hour. In addition, controllers used up to 10 n.m. in additional airspace along the final approach course when no automation advisories were available. The evaluation questionnaire showed strong controller acceptance of the FAST system, and the Denver TRACON chief expressed interest in evaluating this concept at his facility.

A follow-on simulation is scheduled for July. This simulation will determine the benefits of FAST without automation in the Center DA and will evaluate the effects of varying wind conditions. Live traffic evaluations could be conducted as early as 1991 if the FAA chooses to approve the installation of a demonstration system.

### Technical Contact

Tom Davis and Heinz Erzberger, ARC, (415) 604-5452

## Simulator Evaluation of the Final Approach Spacing Tool

---

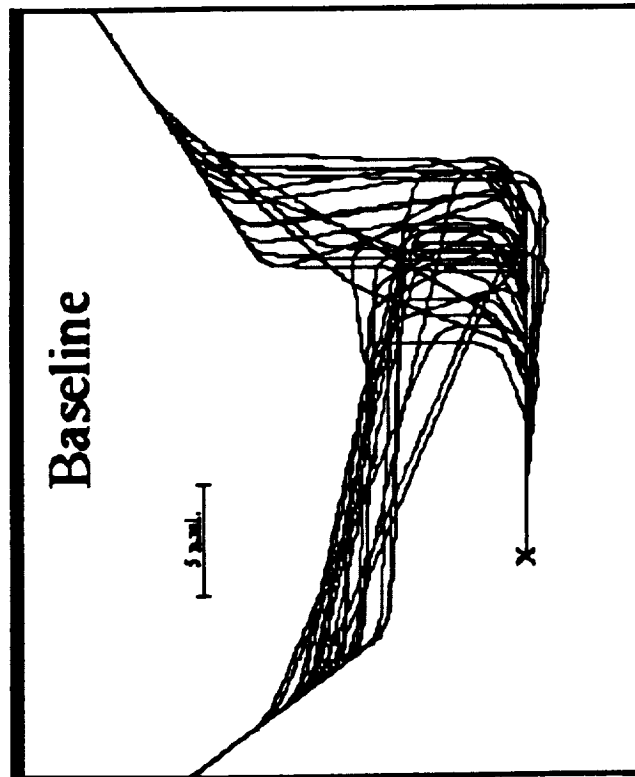

**Landing Rate 38.8 A/C per HR**

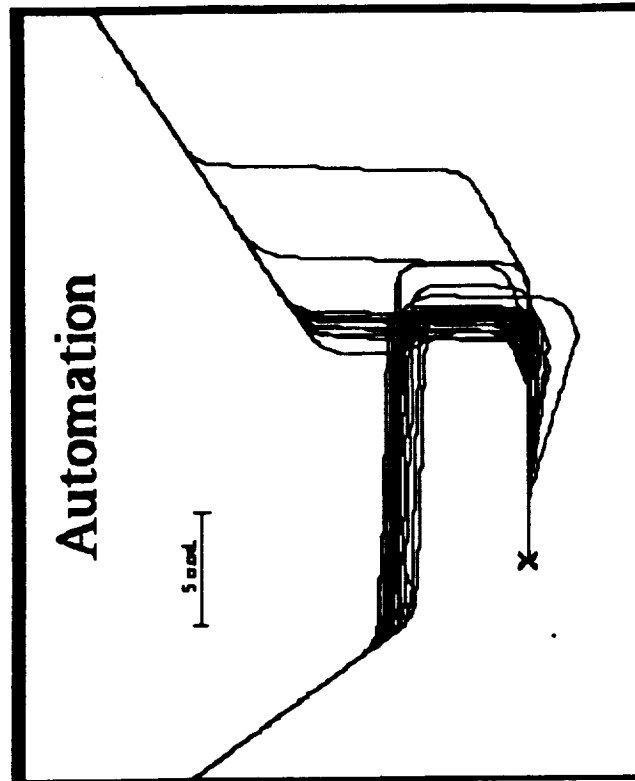

**Landing Rate 43.4 A/C per HR**

**Increase of 4.6 Aircraft/Hour Using Integrated ATC Automation Aids**

## Terminal Area Operations with NAVSTAR Global Positioning System

The Global Positioning System is a constellation of 24 satellites that provides 16-m Precision Military Code (P-Code) navigation accuracy, and 100-m Coarse Acquisition Code (C/A-Code) accuracy. Local corrections to satellite range measurements uplinked to the aircraft are the basis of Differential GPS (DGPS) navigation, which provides an even more precise position solution. Three meter or better accuracy is expected with the current P-Code receivers navigating in the differential mode. The C/A code has been shown to achieve 10-m accuracy in a differential configuration. Even greater accuracies can be achieved by tracking the carrier frequency. Because of the significant improvement in accuracy attainable with DGPS, NASA has entered into a joint program with DoD and FAA to determine the actual improvement based on flight evaluations and to develop operational procedures for making effective use of the DGPS capability.

The project is divided into two distinct phases. Phase 1 will evaluate the differential capability of the NAVSTAR GPS to provide precise three-dimensional positioning and control operations. Phase 2 will evaluate operational uses of DGPS in the civil environment including approach and information using the P-Code of the NAVSTAR GPS in terminal approach and landing and procedures to support more efficient air traffic control operations. A major research activity will be aimed at the development of techniques for tracking the carrier frequency in flight in order to achieve even greater navigational accuracy in support of precision approach and landing guidance.

Hardware components including three P-Code GPS Re-

ceivers, two Inertial Navigation Units, and three VME-based research computers have been installed and tested in laboratory, airborne, and ground systems. Key software modules, including sensor interface, real-time data display and collection, and truth data collection, have been developed and tested. Primary components of the airborne and ground reference systems were installed in a NASA twin turbo-prop aircraft (NASA 701) and a mobile ground reference station. Initial flight tests were completed at the Crows Landing facility. Nineteen approaches in three flights were flown during the period from April 20 to May 8, 1990. The test aircraft was tracked by laser and radar during testing to provide the true position solution.

During the next several months more of the DGPS system software will be developed. Particular emphasis is being placed on development of a navigation filter that integrates information from the GPS Receiver and the Inertial Navigation Unit. Initial flight tests of the fully integrated DGPS system are scheduled for August 1990. Final navigation and guidance system evaluation flight tests are scheduled for November 1990.

Technical Contact

B. David McNally (415) 604-5440

T. Schultz (415) 604-5440.

# Terminal Approach Operations for GPS

King Air



DGPS Mobile Ground Station

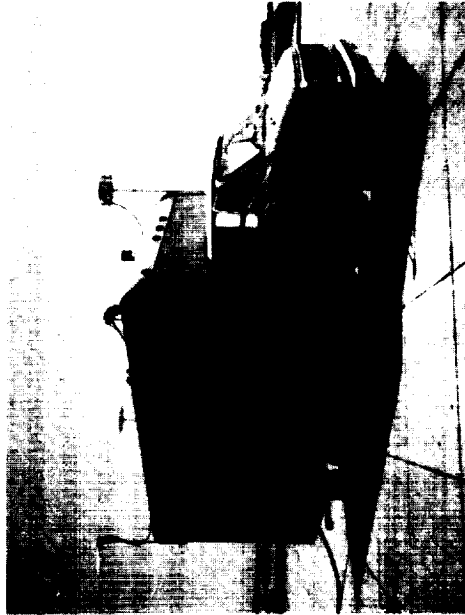

Airborne Equipment Racks

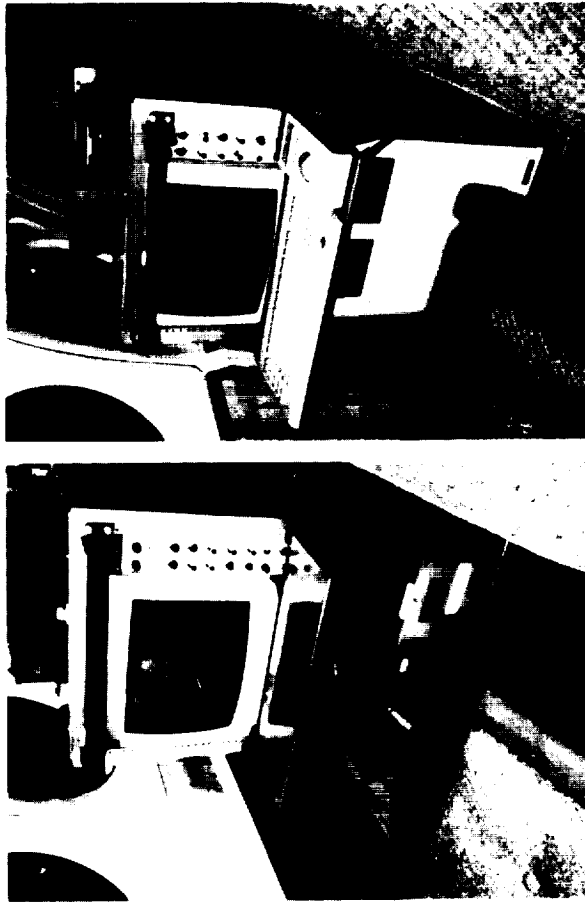

Satellite No. 6 Correction

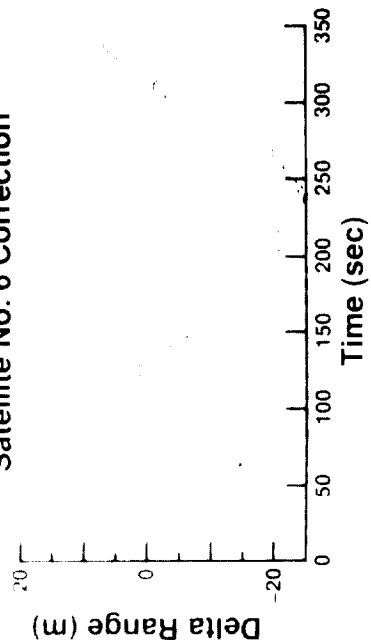

## Validation of Vision-Based Obstacle Detection Algorithms Using Flight Data

The objective of this project is to develop a database from test flight measurements that will allow verification of computer vision obstacle detection and passive range estimation algorithms for use in pilot-aiding during rotorcraft nap-of-the-earth (NOE) flight.

Research in image-based obstacle detection and passive range estimation has led to the development of several candidate algorithms. A real-world data set based on actual flight data is necessary for further development and for evaluating these algorithms for use in NOE applications. In the absence of available real-world rotorcraft data which integrates the required data components, the NOE Image and Truth (NOE-IT) Data Acquisition Test Flight Project has been undertaken to develop data necessary for implementation and validations of a computer vision based obstacle detection system. Implementation of the system will require three major data components: (1) video imagery data; (2) motion states of the video camera; and (3) camera calibration parameters. Validation requires direct measurements of the obstacle range relative to the rotorcraft for comparison with the results of the vision-based passive ranging algorithms. In addition, the video imagery, motion state measurements, and true range information must be correlated with respect to time.

NOE-IT employs an instrumented Boeing CH-47B Chinook (NASA 737) as a testbed on which a video camera and recording equipment is installed to provide the imagery data. Rotorcraft motion is obtained from the inertial navigation unit and other on-board instruments whose output is transmitted to a ground station. With the results of the calibration analysis, the camera motion states can

be derived from the directly measured rotorcraft motion. Laser tracking provides ground truth measurement of the rotorcraft's location, while both laser tracking and surveying provide the obstacle locations to complete the data set.

Significant post-flight processing is required to transform the raw measurements collected during test flight into a form suitable for the validation of passive range estimation algorithms. Calibration of the camera is necessary to accurately determine its position and orientation with respect to the helicopter body axes so that rotorcraft state measurements may be transformed into the camera's axes system. It is also used to determine the camera's internal properties such as the focal length which are used directly by the vision algorithms. State estimation techniques are required during post-flight processing to ensure internal consistency among rotorcraft state measurements before algorithm validation can be undertaken.

A full camera calibration analysis has been performed leading to the development of a new calibration methodology, and state estimation techniques have been employed to ensure internal consistency among rotorcraft state measurements. Focus is on completion of consistency checking between the video imagery, camera motion, and true range measurements to demonstrate integrity of the data set prior to use in research and validation activities.

### Technical Contact

Phillip Smith, ARC, (415) 604-5469  
Banavar Sridhar, ARC, (415) 604-5450



# Validation of Vision-Based Obstacle Detection Algorithms Using Flight Data

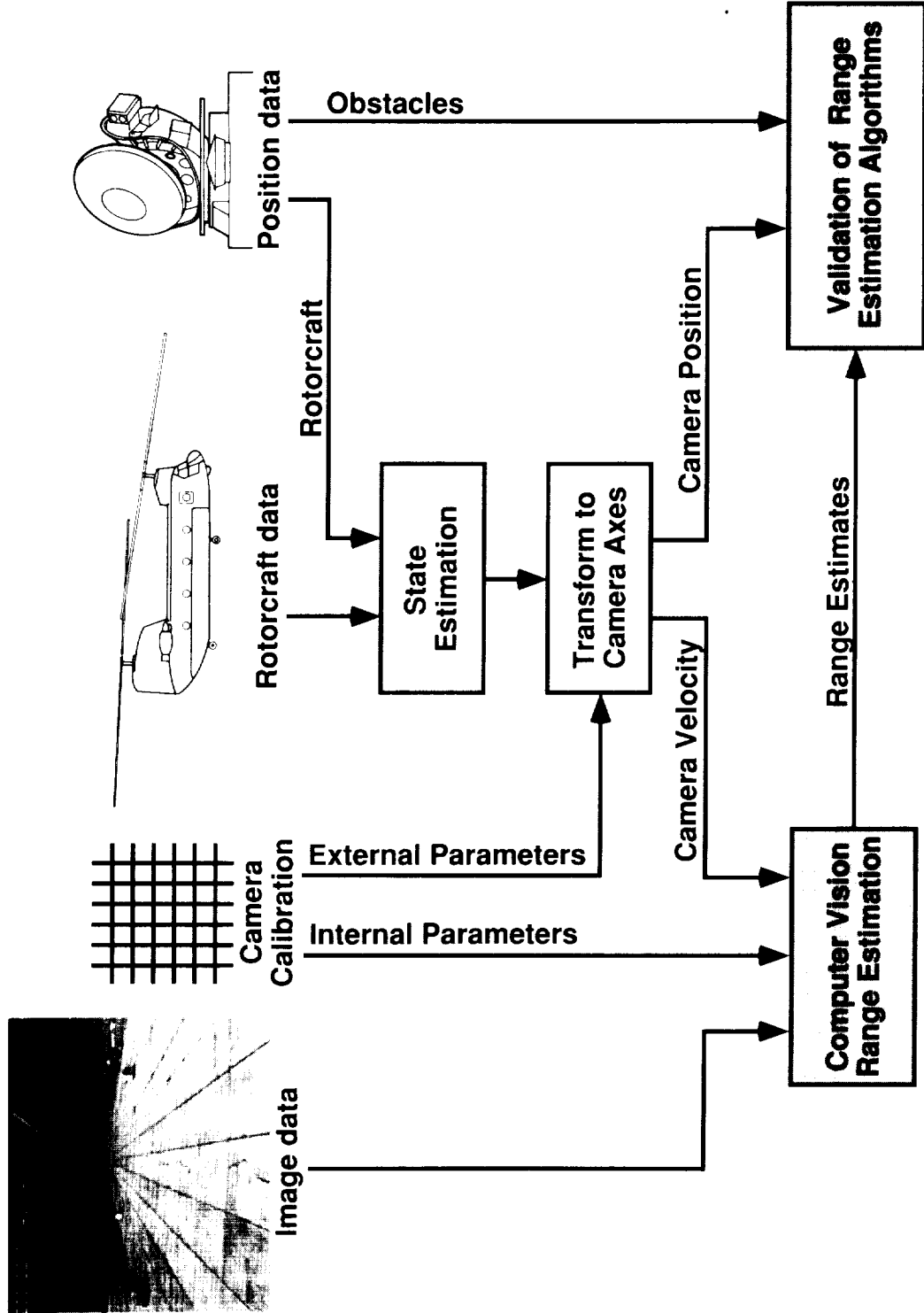

ORIGINAL PAGE  
BLACK AND WHITE PHOTOGRAPH

## Automated Flight Test Management System (ATMS) Flight Test Engineers Workstation

---

The Automated Flight Test Management System (ATMS) Flight Test Engineers (FTE) workstation is a tool that combines numeric and symbolic computation to aid in the planning, scheduling, and validation of a flight test program. The ATMS combines expert system technology with conventional numeric processing to provide a flight test planning tool, on-line simulation of the flight, and automatic flight card generation.

ATMS allows the flight test engineer to plan research flights at the block, flight, and maneuver levels. An expert system then arranges the maneuvers in a flight to optimize fuel, range, and time. After the flight has been planned, on-line simulations can be run to validate the flight. Finally, ATMS aids in the preparation of the flight cards that are used in the actual research flight.

ATMS significantly aids the flight test engineer by capturing and utilizing knowledge about flight test planning. ATMS also aids in the validation of planned flights and helps to automate the time-consuming task of flight card preparation.

ATMS has evolved over the past year from a prototype to an operational system. ATMS is currently being used to plan research flights for the F-18 High Alpha Research Vehicle. Several organizations such as the Air Force Flight Test Center, Lockheed, and McDonnell Douglas have shown interest in ATMS.

### Technical Contact

Eugene L. Duke, ADFRF (805) 258-3802

# Automated Flight Test Management System

FLIGHT #	_____
MANEUVER	_____
ALTITUDE	_____
VELOCITY	_____
...	_____
...	_____
...	_____

**Flight card  
generation**

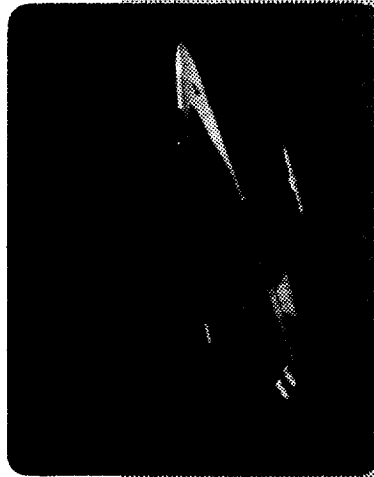

**Research flight**

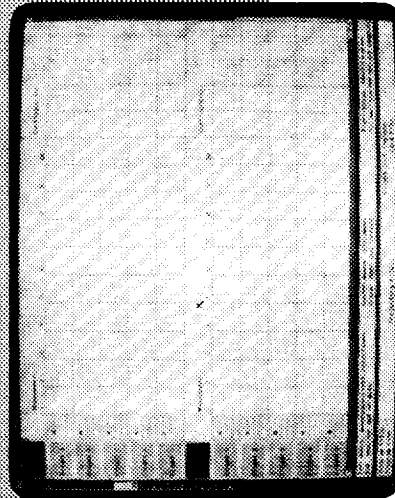

**Flight test planning**

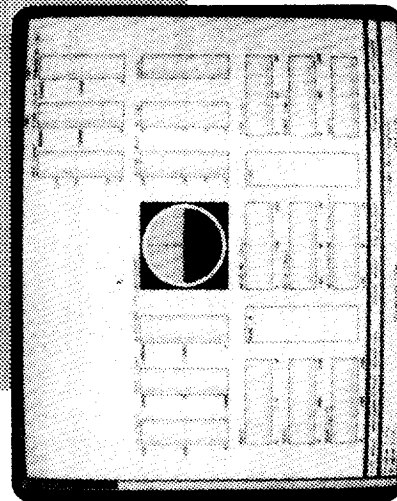

**On-line simulation**

## Features

- Tool for flight test planning, scheduling, and validation
- Presently in use on Sun workstation to plan F-18 HARV flights
- In final stages of porting to the X window system

## X-29 High Angle-of-Attack Controls Technology

The X-29 is a single-seat fighter-type airplane with a 30 degree forward-swept wing. The airplane, designed and built by Grumman Aerospace Corporation, was specially modified for high angle-of-attack (AOA) flight to include a spin recovery chute system and a specially modified high AOA flight control system.

The software and hardware that make up the flight control system were modified to provide three-axis maneuvering up to wing stall and to provide pitch pointing capability up to the maximum AOA (40 and 70 degrees, respectively). These control laws were built on the original control laws with enhancements that start to fade in at moderate AOA. Most of the changes in the control laws were made to simplify the feedback structure. At high AOA the control system was designed such that lateral stick movement commands the velocity vector roll rate (no AOA and sideslip coupling). The aileron commands are strictly a function of pilot lateral stick and roll rate feedback. The rudder command is computed from pedal inputs, lateral stick (ARI for coordination) through a lead-lag filter, and washed-out stability axis roll rate feedback loop. The high gain pitch control of the low AOA flight control system was generally sufficient for high AOA. Modifications included changes to the Automatic Camber Control schedules, AOA feedbacks added to provide long period pitch stability, and AOA and g-limiters. These control law changes were designed primarily using the nonlinear simulation. High AOA flight control concepts were checked using linear analysis, but the nonlinearities of high AOA require a nonlinear simulation. Hardware-in-the-loop and airplane-

in-the-loop simulations were used for verification and validation testing.

Initial flight tests have demonstrated a much better than expected wing-rock free envelope (up to 35 degrees AOA). The wing-rock that develops is very mild and lateral-directional control degraded in a graceful manner, according to the X-29 pilots. Stability axis roll rates have proved to be similar to the predictions and are shown in the accompanying figure. In-flight Dial-A-Gain tests have shown that even higher roll performance is possible with reduced roll rate feedback without noticeable wing rock up to 35 degrees AOA (approximately a 15% increase in rate for a 20% reduction in feedback gain). Pitch axis control was less than predicted, largely due to high levels of static instability, which did not decrease as much as expected with increased AOA. To offset this, a flight control system modification was made to increase the pilot pitch axis control power by 30 to 100% across the flight envelope.

More flights to test fully the high AOA capabilities, the military utility and agility of the X-29, and surface and vortex flow patterns are planned for late summer FY 1990 and early to mid FY 1991.

Technical Contact

Robert Clarke, ADFRF, (805) 258-3799

# X-29 High Angle-of-Attack Controls

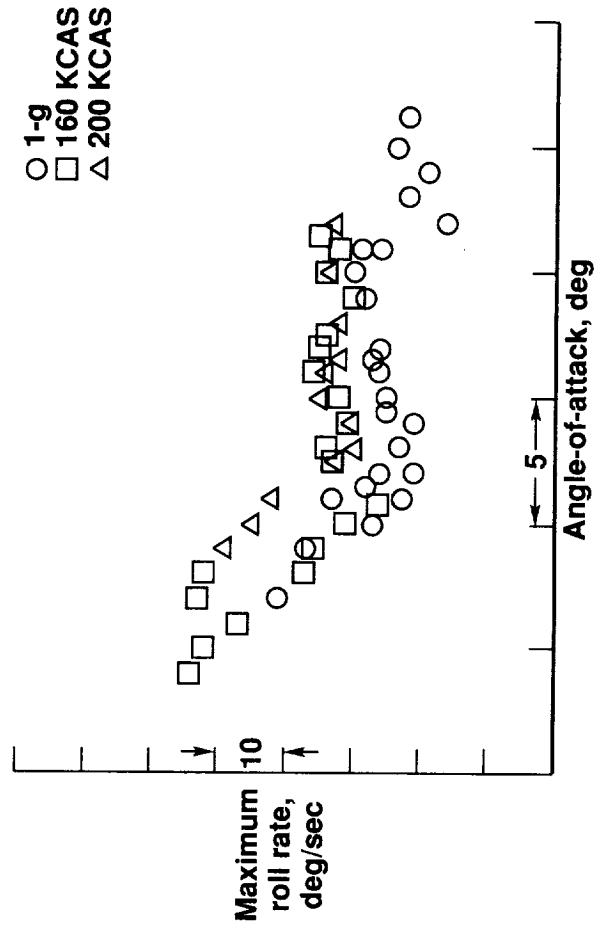
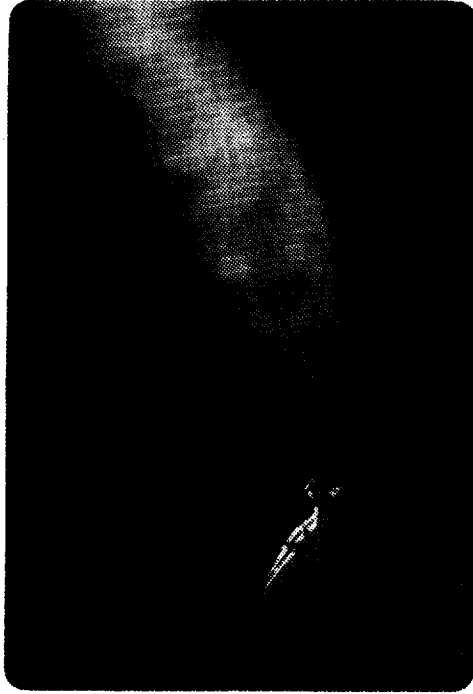
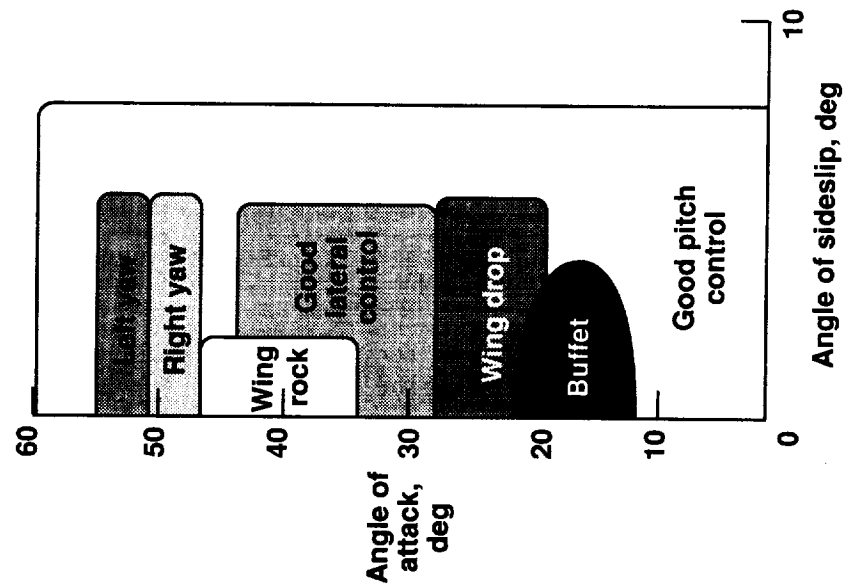

## Demonstrated Incompatibility of Airborne and ATC-Generated 4D Descent Profiles

Advanced Air Traffic Control (ATC) systems are being developed which contain time-based (4D) trajectory predictions of aircraft. Incompatibilities between these ATC-generated profiles and those generated by airborne 4D Flight Management Systems (FMS) may introduce system problems. The objective of this effort was to operate an airborne 4D FMS in a 4D ATC system with known speed strategy differences.

The Langley TSRV cockpit simulator, flown by airline pilots, was linked in real-time to the Ames Descent Advisor (DA) simulation, operated by active air traffic controllers. Computer-generated traffic was directed by DA-generated speed and descent commands by the controllers to achieve scheduled metering-fix arrival times. The TSRV cockpit used on-board FMS-generated speeds to achieve arrival times specified by the controller. Figure 1 provides a comparison of minimum fuel and ATC speed schedules versus assigned flight time for the test scenario. Test conditions were flown with TSRV using either the minimum fuel (incompatible) or ATC (compatible) speed strategy. Figure 2 illustrates the worst-case separation conflict that could occur with incompatible speed schedules. An offset route scenario was also tested to allow TSRV to fly the minimum fuel speed schedule on a parallel route to avoid the in-trail separation conflict.

The 4D procedures and FMS operation were well received by the airline pilots, who achieved an arrival time accuracy of 2.9 seconds standard deviation time error. Incompatibility between airborne and ATC-generated speed sched-

ules produced numerous traffic conflicts that required controller intervention. With compatible speed schedules, no conflicts were encountered. The offset route scenario was found to be confusing to the controllers and less efficient than flying compatible speeds on the same route. When heavy traffic forced vectoring of all traffic, compatibility of speed schedules was no longer an issue since all aircraft were at minimum speeds.

These tests demonstrated that incompatibility between 4D airborne and ATC speed schedules can result in unacceptable system performance. The relatively modest efficiency advantage of minimum fuel speed schedules can be lost when ATC intervention is required to prevent conflicts. Further work is required to develop procedures and/or identify information transfer between air and ground needed for successful, cooperative time-based ATC.

Additional joint experiments are planned as 4D ATC concepts evolve. Specific areas of interest are wind modeling errors, data-link transfer of trajectory parameters, and refined 4D clearance procedures designed to prevent in-trail conflicts.

Technical Contact

David H. Williams, LaRC, (804)864-2023

## 4D Trajectory Generation Techniques

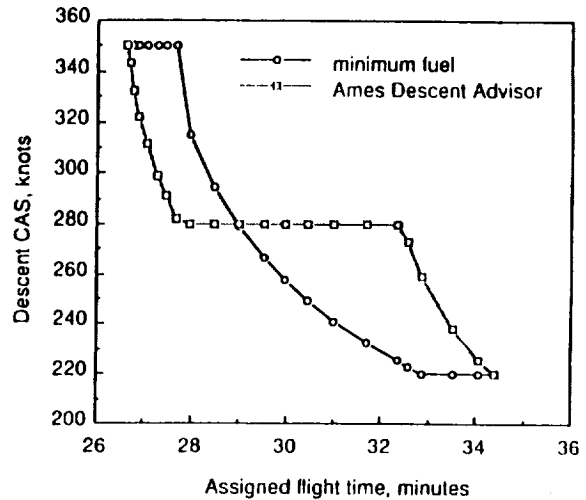
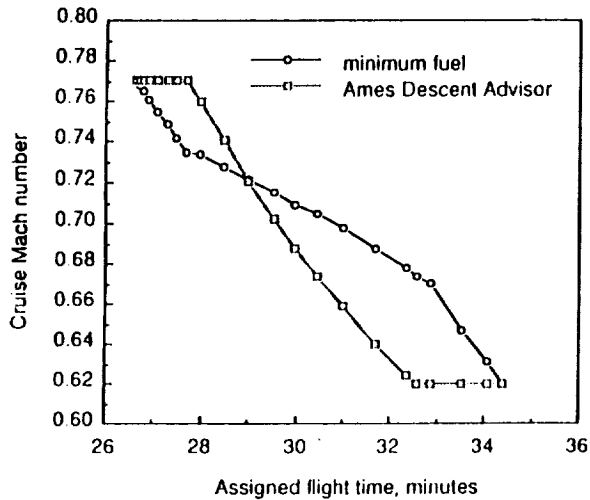

## Separation Conflict Induced by Incompatible Speed Schedules

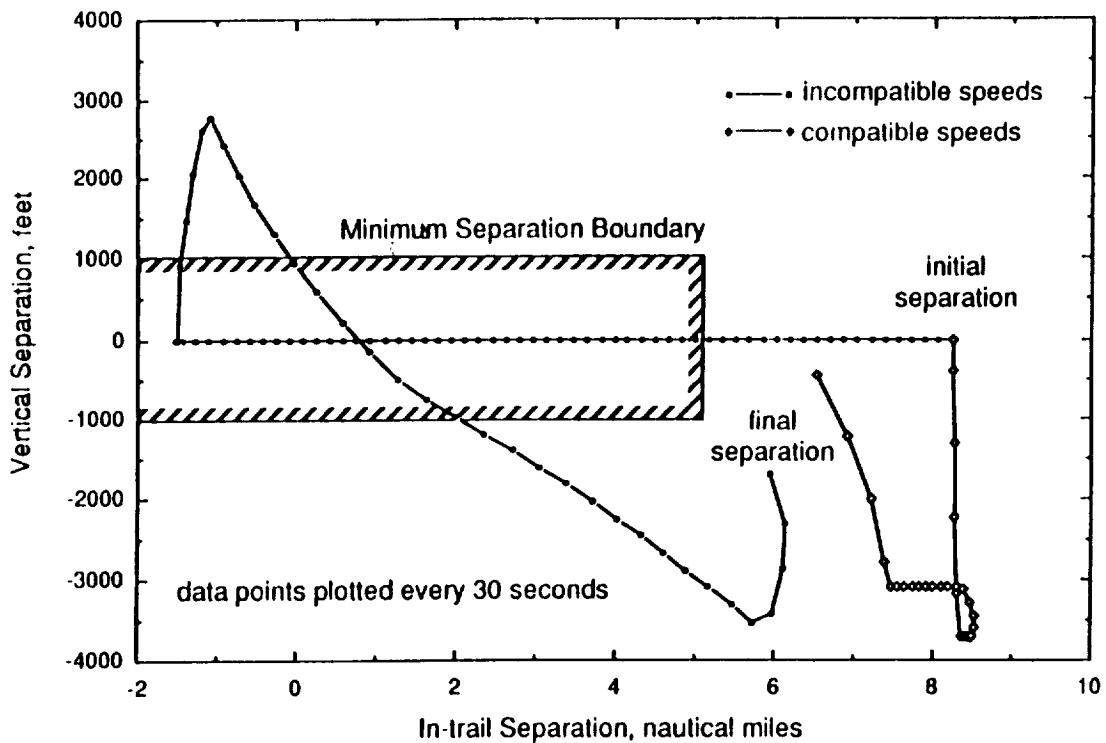

## Evaluation of Candidate Wind Shear Detection and Clutter Suppression Algorithm

A number of candidate wind shear detection and clutter suppression algorithms have been developed. These include (1) ground clutter reduction and rejection by antenna tilt control, range limiting, wide receiver dynamic range with separate AGC for each range bin, and use of various clutter rejection filters, both fixed and adaptive; (2) derivation of average wind velocity and spectral width in each range cell by use of adjacent pulse-pair and/or FFT Doppler spectral averaging; (3) derivation of the horizontal shear hazard index (F-factor) using the velocity measurements over several range bins. This technique minimizes the effect of erroneous velocity measurements from moving ground clutter, since moving clutter targets generate wide Doppler spectra in comparison to weather spectra; and (4) for each azimuth scan of the radar, the centroid and area of hazardous regions that exceeds a hazard index threshold is calculated.

Hazardous regions with areas greater than a specified size are tracked from scan to scan. Small areas are not tracked, since these areas are usually false targets resulting from moving vehicles or small wind shear areas not hazardous to aircraft. If a hazardous region is tracked for a number of scans and its centroid is within 30 to 40 seconds of the aircraft, an alarm is sounded and a display showing the location and extent of the hazardous area is provided.

The accompanying figure shows displays generated by simulating a radar mounted on the UAL 395 aircraft scanning the July 11, 1988 Denver microburst, during landing at Stapleton Airport. The left display shows contours of measured radial velocity, through the microburst, over a range of 0.5 to 5 km and azimuth angle range of  $\pm 21^\circ$ . Velocity contours from moving vehicle ground clutter can be seen at the outer range of the display.

The right display shows contours of hazard index with a shear hazard area in the microburst correctly identified by the radar. Antenna tilt control, weighted least-squares hazard estimate, and hazard area tracking algorithms were utilized in this simulation. The false hazards produced by moving vehicles were either suppressed or ignored by the radar.

Signal and data processing algorithms that incorporate range limiting, antenna tilt control, clutter filtering, least-squares estimation, and hazard tracking have been developed. Simulation studies using these algorithms have shown the microburst wind shear hazards can be successfully detected in the presence of severe ground clutter. Had a Doppler radar incorporating these algorithms been operating on UAL 395, the pilots might have been warned in sufficient time to avoid the hazardous wind shear.

Technical Contact  
Emedio Bracalente, LaRC, (804) 864-1810



**Evaluation of Candidate Wind Shear Detection and Clutter  
Suppression Algorithm**

**WINDSHEAR RADAR DISPLAYS OF  
JULY 11, 1988 DENVER MICROBURST**

**Wind Velocity  
Display**

**Windshear Hazard  
Display**

Antenna TR - 2.7°

21° -211

50 50

50 50

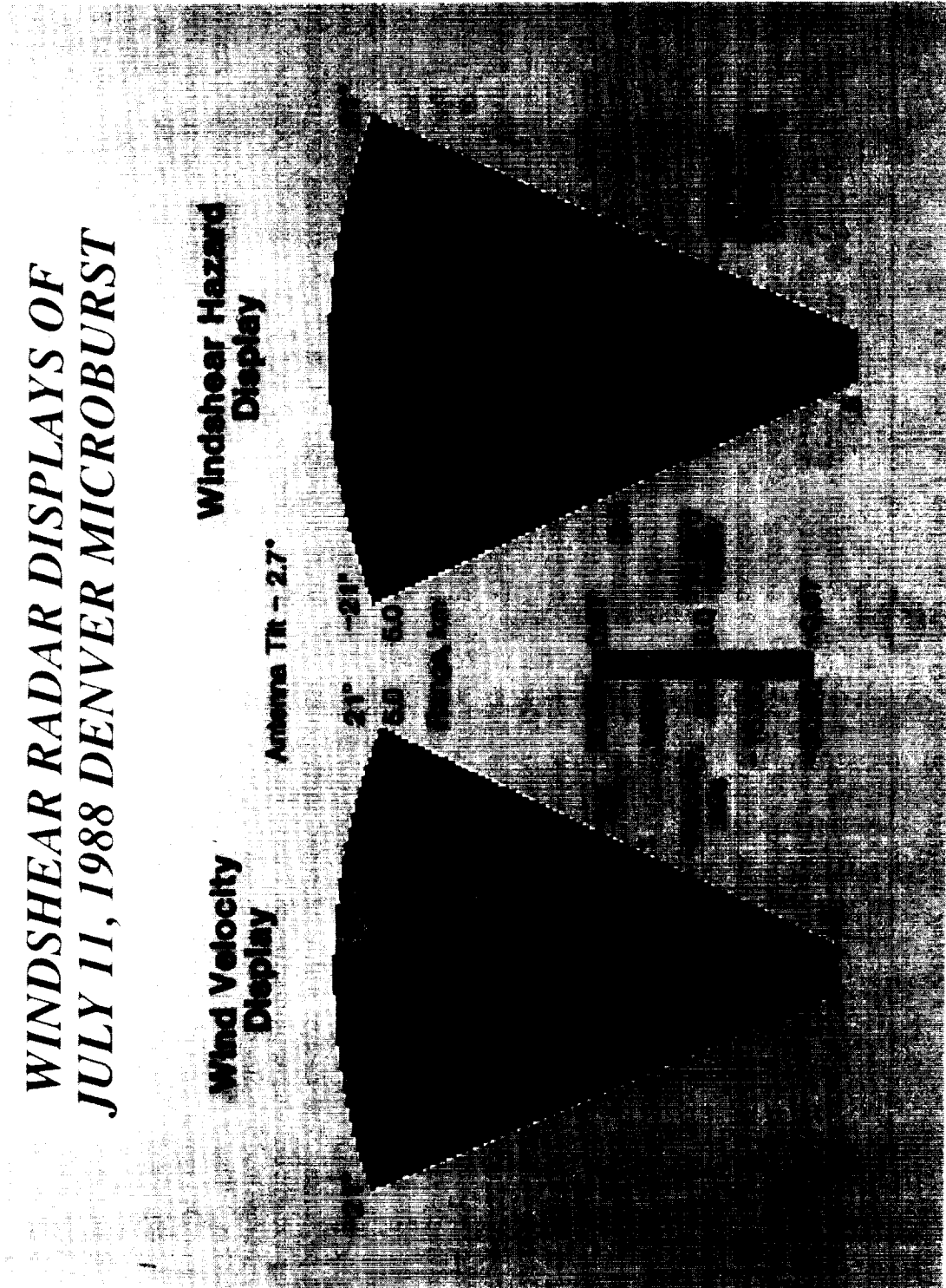

ORIGINAL PAGE  
BLACK AND WHITE PHOTOGRAPH

## Flutter Suppression On An Active Flexible Wing

The objective of this research is to design a flutter suppression system and experimentally demonstrate the ability to significantly expand the operational envelope of an advanced aircraft configuration by exploiting active control technologies.

A full-span, free-to-roll, active flexible wing (AFW) wind tunnel model (see graphic) was used as a testbed for demonstrating active flutter suppression. A linear math model of the airframe (with roll motion restrained) was used to design a flutter suppression system (FSS). The design method employed root locus and Nyquist techniques and relied on a fundamental physical understanding of the flutter mechanism. A unique aspect of the design is that it takes advantage of an effective pole/zero cancellation associated with the first wing torsion mode at low dynamic pressure, and pole/zero migrations with variations in dynamic pressure. The design was performed in the continuous domain but was implemented digitally. The design was evaluated and fine tuned using a high fidelity, nonlinear simulation. The AFW model was then "flown" in the Transonic Dynamics Tunnel to evaluate the validity of the math model, identify flutter boundaries, and test the FSS.

The FSS was shown to successfully stabilize the vehicle, despite discrepancies in the design model, to a dynamic pressure 45 psf above flutter. Though the math model of the AFW proved to represent the key aspects of the flutter mechanism, there were considerable differences between the flutter frequency (and flutter dynamic pressure) predicted by the math model and that observed experimentally. At a dynamic pressure of 270 psf, turbulence in the wind

tunnel induced structural deformations that exceeded preset safety limits. However, the control system was still adding sufficient damping to stabilize the vehicle with commanded control surface deflections and rates well within allowable limits. The control system also exhibited excellent stability margins as measured by experimentally determined singular value and Nyquist plots. As an added benefit, the FSS demonstrated significant gust load alleviation properties below flutter as indicated by reduced acceleration levels.

This study demonstrated that clean-wing flutter suppression is feasible and it reinforced the need for accurate modeling and a thorough understanding of the physical phenomenon being controlled. Positive design attributes include suppression of flutter 20% above the open-loop flutter point, simplicity of implementation, gust load alleviation properties, and robustness to uncertainties in flutter frequency and flutter dynamic pressure.

Future work will initially be aimed at determining the actual closed-loop flutter point for the current FSS. Additional damping will be added via the FSS to decrease the response to turbulence and so increase the operational limit of the FSS beyond a dynamic pressure of 270 psf. Additional design improvements to increase the flutter dynamic pressure of the closed-loop system beyond the current limit will be investigated, as will the potential for simultaneously suppressing flutter while executing rapid rolling maneuvers. A wind tunnel test to address these objectives is tentatively planned for mid-1990.

Technical Contact

Martin R. Waszak, LaRC, (804) 864-4015

# Flutter Suppression for Active Flexible Wing

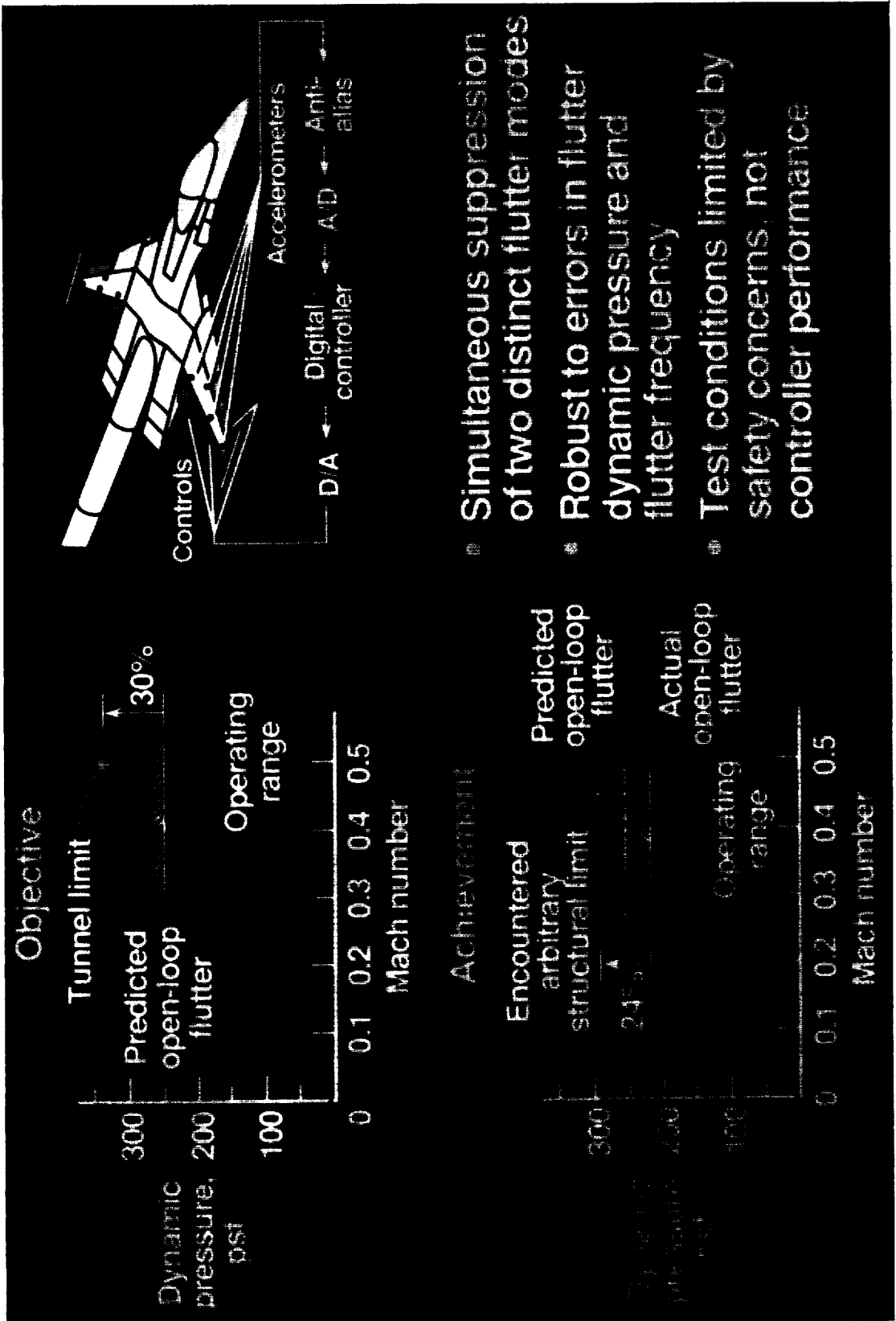

## High-Temperature Fiber Optic Microphone

---

The objective of this program is to investigate and develop improved fiber optic/electro-optic, detection and sensing systems for the fiber optic microphone in order to extend its minimum detectable sound pressure level (SPL) by 54 dB.

The fiber optic concept was developed by Dr. A. J. Zuckerwar (NASA LaRC) and Prof. F. W. Cuomo, University of Rhode Island (URI). It has the potential to achieve the high temperature (2000 °F) and high frequency (200 KHz) response required for aeroacoustic load measurements needed for National Aero Space Plane (NASP) development and flight testing. This capability has been identified by General Dynamics as a key sensor technology development for the X-30 research vehicle and is supported by the NASP Joint Project Office. This sensor is targeted to meet the required combined performance range of 130-190 dB (ref. 20 µPa) SPL, 200 KHz bandwidth, and to operate at temperatures up to 2000 °F.

The first prototype fiber optic microphone, which was built at LaRC and tested at URI, was found to have a minimum detectable SPL of 146 dB — 16 dB above the required minimum level. An examination of the fiber optic sensor data link was conducted in the IRD fiber optic sensor laboratory, and noise sources were identified. The amplifier has been redesigned to include a new ultra-fast photodiode/op-amp, which has a nominal minimum detectable power level of 10 nW and a bandwidth that exceeds the required 200 KHz. A DC offset is provided to balance out the detector quiescent level which increases the system detectable range. The minimum detectable SPL was decreased to 131 dB (10 Hz BW). An electrostatic actuator will be used to calibrate the sensor at high temperatures. Since the actuator has a maximum SPL of 92 dB, it will be necessary to further reduce the minimum detectable SPL

of the sensor. This improvement in minimum SPL will require narrowing the bandwidth to 1 Hz and increasing the fiber optic optical power from 40 to 600 µW.

Technical Contact

A. J. Zuckerwar, LaRC, (804) 864-4658

# High-Temperature Fiber Optic Microphone

## Prototype microphone

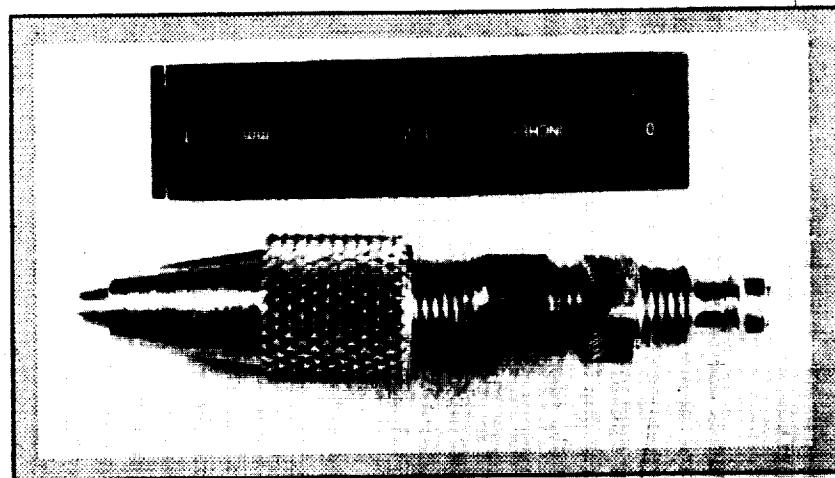

## Performance requirement/results

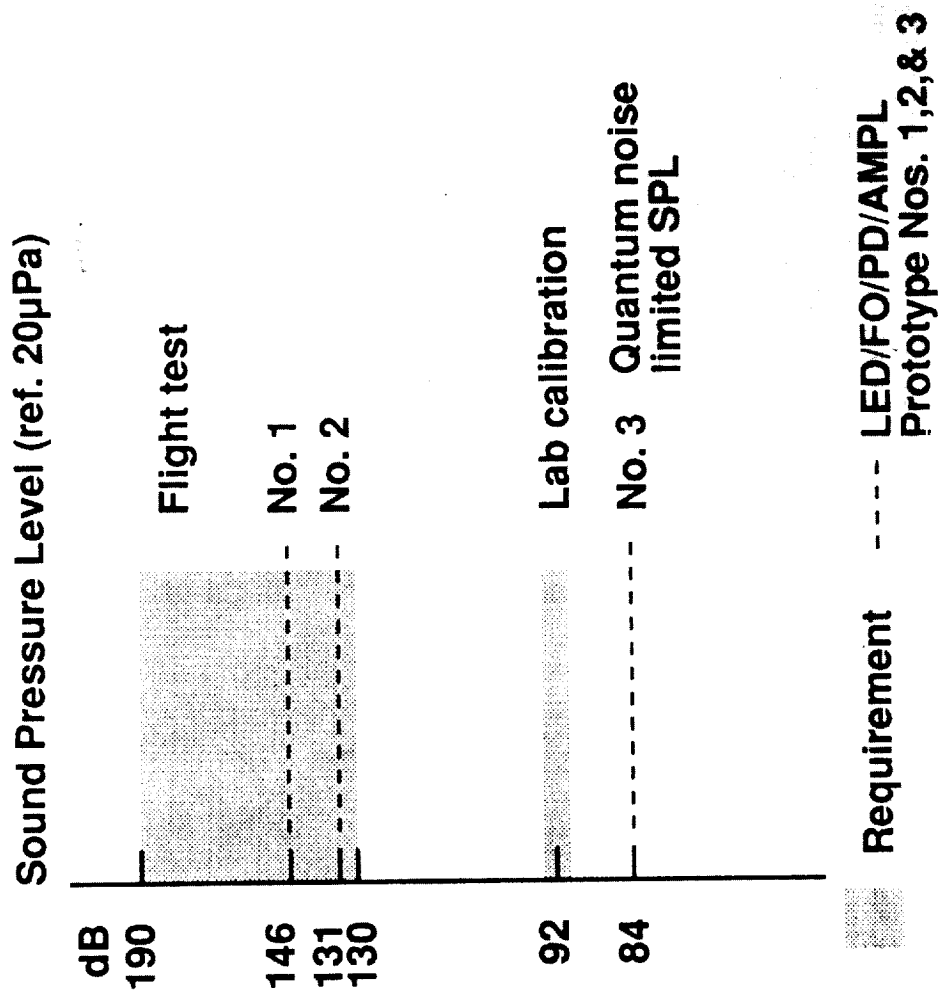

## Laser Induced Fluorescence Diagnostics

The objective of this program is to develop Laser Induced Fluorescence (LIF) techniques for visualization and quantitative measurements in supersonic and hypersonic flow fields, with particular emphasis on supersonic combustion.

One of the most critical technology needs in the Agency's hypersonic propulsion technology and computational fluid dynamics (CFD) validation research program is the need for spatially resolved, disturbance-free measurements of local gas flow properties of chemically reacting flows. The newly evolving nonintrusive diagnostic of LIF will provide much of the needed research data. Specifically, a high-power, tunable ultraviolet excimer laser will be used to generate LIF in OH and O<sub>2</sub>, and an intensified solid state camera will be used to record and quantify the resultant 2-D fluorescence.

The solid-state camera system is presently operational and the excimer laser was received from the manufacturer in June 1990. Laboratory research has continued during the excimer procurement phase using an existing Nd:YAG pumped dye laser system. Using this system, we have demonstrated 1-D visualization of OH along a line in a flat flame burner and single point measurements of O<sub>2</sub> LIF in a heated cell. The preliminary dye laser studies demonstrated that it is possible to locate a single laser frequency which will simultaneously excite two upper state vibrational levels. By recording the ratio of line intensities from these levels, it is possible to determine the gas temperature using a single laser pulse. Single pulse capability with LIF is particularly important to high speed combustion diagnostics where it is necessary to "freeze" the flow in order to study the turbulent fluctuations. These techniques will be demonstrated this coming year in test cell 2.

The excimer-intensified camera system will provide the capability of taking 2-D "freeze-frames" of density and temperature in fluid flows. In particular, it will provide O<sub>2</sub> and OH snapshots for studying hypersonic and combustion flows. Other gases, such as NO and H<sub>2</sub>O, also will be studied using this technique.

Technical Contact

R. J. Balla, LaRC, (804) 864-4608

# Laser Induced Fluorescence Diagnostics

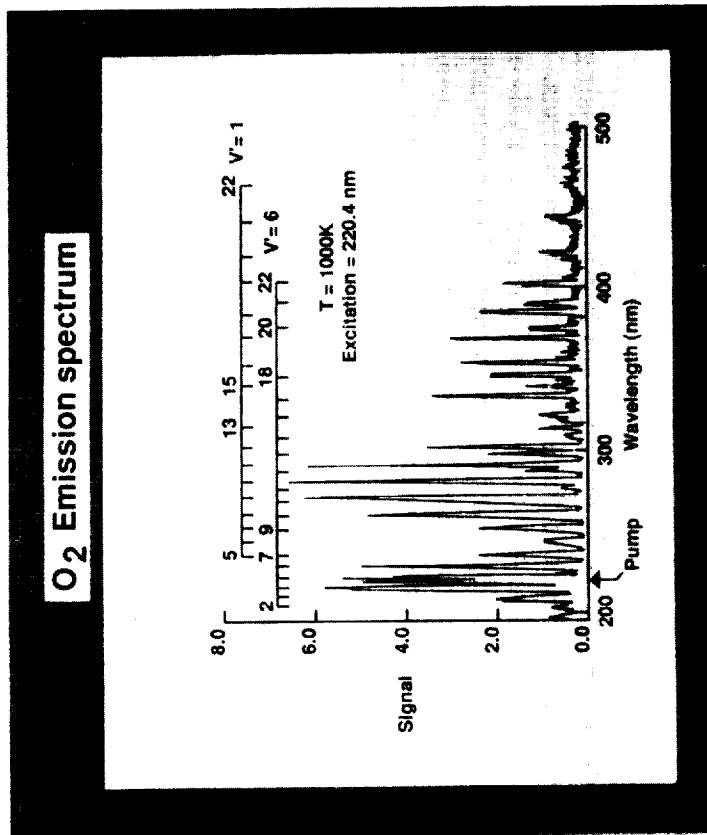
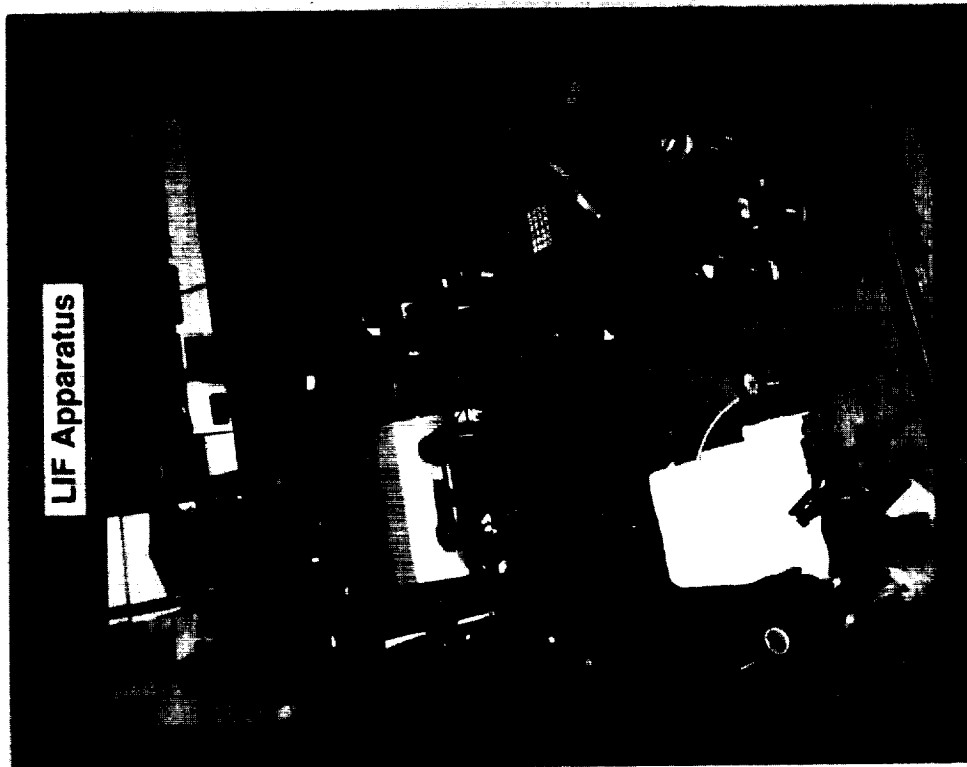

## Validation of Methods for Predicting Hypersonic Flight Control Forces and Moments

Before assessing flight control systems for hypersonic vehicles, it is important to understand the strengths and limitations of prediction tools. For conceptual control design a set of tools has been integrated into an industry-standard computer program, the Aerodynamic Preliminary Analysis System (APAS). Although several studies have examined this code's ability to predict overall vehicle dynamics, no systematic study has explored its ability to predict the control forces and moments generated by the aerodynamic effectors. Thus, the goal of this activity was to determine the range and accuracy of APAS for predicting control forces and moments for hypersonic vehicles.

An assessment of the capabilities for predicting flight control forces from low subsonic to high hypersonic speeds, including the subsonic/supersonic panel methods and hypersonic local flow methods, which are part of APAS, was undertaken. The validation effort covered three configurations for which wind tunnel and/or flight test data are available, namely the Space Shuttle Orbiter, the North American X-15, and a hypersonic research airplane concept.

Predicted control forces and moments generated by various control effectors were compared with previously published data. Results indicate that predictions of longitudinal stability and control derivatives are acceptable for conceptual controls design use. Results for most lateral/directional control derivatives are acceptable for conceptual design purposes; however, predictions at supersonic Mach numbers for change in yawing moment due to aileron deflection and the change in rolling moment due to rudder deflection are not acceptable. Including shielding

effects in the analysis has little effect on lift and pitching moments while improving drag predictions.

The accomplished research provides a first step toward a computationally efficient method for predicting flight control forces and moments. The accuracy range and validity of APAS as a predictive code is established for suitability as a conceptual design tool. Also, a catalogue of existing data for comparison with other prediction methods is available.

A second phase of research has begun for assessing uncertainties in the force and moment predictions. Improvements to APAS will be made after an analysis of the physics is undertaken. For example, if moments are not predicted well because pressure distribution is not predicted well, appropriate modification to the code will be implemented.

Technical Contact

John D. Shaughnessy, LaRC, (804) 864-4014



# Prediction of Forces and Moments for Flight Vehicle Control Effectors

Predictive Codes compared with exp't'l data.



North American X-15



Hypersonic research airplane

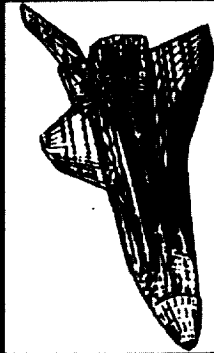

Space shuttle orbiter

- Objective
  - Examine abilities of aerodynamic codes for predicting controls forces and moments
- Approach
  - Assess accuracy and range of codes
    - Subsonic/supersonic panel
    - Hypersonic inclination
    - Viscous/wave drag

## Assessment of Control Derivatives

$$C_{L_{\delta_e}} \quad C_{D_{\delta_e}} \quad C_{m_{\delta_e}} \quad C_{n_{\delta_a}} \quad C_{l_{\delta_a}} \quad C_{n_{\delta_v}}$$

$M_\infty$

Subsonic

Transonic

Supersonic

Lo hypersonic

Hi hypersonic

• Coverage: trends ok, magnitude poor, not useful

- Accomplishments Summary
  - Accuracy, range, validity of codes demonstrated
  - Anomalies identified
  - Suitability for use in design established
  - Uncertainty analysis conducted



## **Controls and Guidance - Space**

The Space Controls and Guidance Research and Technology Program is directed toward improving the next generation of space transportation systems: the President's Lunar/Mars Initiative, large future spacecraft, space systems such as the Space Station, large communication antennas, and high-precision segmented reflector telescopes and interferometers. The new generation of transportation vehicles is being challenged with demanding requirements to provide an order of magnitude reduction in cost as well as an increase in capability; the Lunar/Mars Initiative will require reliable avionics systems; and future orbital facilities will have demanding control requirements for pointing and stabilization, momentum management, build-up and growth accommodation, and disturbance management.

To address advanced launch requirements, research and technology for adaptive guidance is being pursued. A forward-looking laser, detecting wind velocity in advance of the vehicle, provides the data for calculating, on board, the desired load alleviation trajectory. This technology has the capability to provide large reductions in operations support in the planning and generation of the mission software and mission control. In support of the Lunar/Mars initiative, the Advanced Information Processing System (AIPS) forms the basis for our research and technology program into highly reliable fault tolerant distributed control systems. AIPS, along with long-lived, reliable avionic system components, will greatly assist our ability to realize the President's Initiative. For complex space systems, computational controls are being developed to provide cost-effective, high-speed, high-fidelity control system simulation and analysis and synthesis tools. The thrust of this work will be to develop methods and software to enable a 4 orders-of-magnitude improvement in analysis and real-time hardware-in-the-loop simulation for control design certification. To address future orbital facilities requirements, an advanced technology program is under way in system identification, distributed control, and advanced sensors and actuators. A new area is under way utilizing advances being made in microsensors and motors for acceleration and rate gyros; this produces highly reliable systems based on high multiples of hardware redundancy.

Program Manager: John D. DiBattista  
NASA/OAET/RC  
Washington, DC 20546  
(202) 453-2743

## Adaptive Control Subsystem Development

---

The research objective is to develop an adaptive control subsystem for application to emerging space systems, including future large flexible spacecraft, space platforms, and advanced space exploration vehicles. The overall approach involves a multilevel adaptation methodology to provide controller designs that ensure high performance in the presence of major system changes, such as large parameter jumps, hardware failures, anomalies, operational disturbances, and changes in mission objectives, as well as, local phenomena including drifting parameters, model uncertainties, and environmental disturbances. This concept will provide robust stabilization and control with enhanced performance for future space systems.

Accomplishments in FY 1990 have been made in both the theoretical and experimental fronts. On the theoretical front, a new adaptation technique, denoted as auto-tuning, has been developed for vibration damping of spacecraft having non-collocated actuators and sensors. A second theoretical advance proves that for structures with collocated actuators and sensors, there always exists a bounded feed-forward gain, which guarantees stability of the closed-loop adaptive system in the presence of a pure time delay. Experiments were successfully conducted which validated this latter result and demonstrated robustness of the adaptive algorithm to input saturation and time delay effects.

Research and development for FY 1991 includes the further advancement of the state of the art for adaptive control of non-collocated spacecraft. Theoretical work covering concept development, algorithm design, and

stability analysis for single-input/single-output algorithms are scheduled for this coming year. On the experimental side, the six-input/six-output adaptive regulator design will be extended to the model reference tracking problem, further advancing unprecedented work on experimental adaptive control for multivariable systems of this size.

### Technical Contact

Shyh J. (Don) Wang, JPL, (818) 354-7288  
 Fred Y. Hadaegh, JPL, (818) 354-8777

# High Performance Adaptive Control

**Goal:**  
Develop a Multi-Level Autonomous Adaptive Control System for Advanced Spacecraft

- Payoffs:**  
Enabling Technology for
- On-Board Spacecraft Autonomy
  - High Performance Control in Uncertain and Time-Varying Environments
  - Advanced Control for Space Exploration Missions

- Accomplishments:**
- Developed Robust Multivariable Adaptive Theory and Experiment
  - Demonstrated Robustness to Time Delay and Saturation
  - Developed Auto-Tuning Adaptation Concept

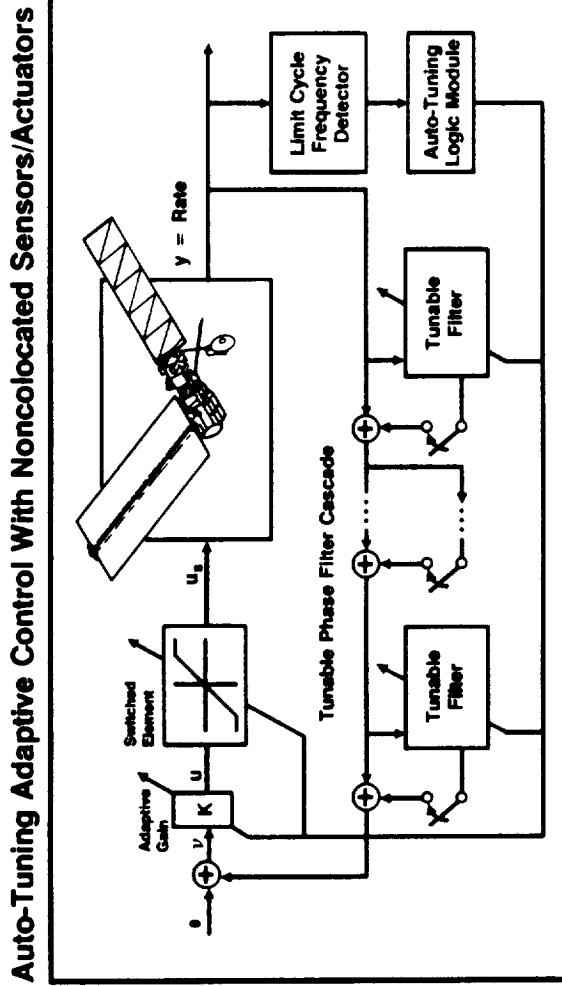

- Burst Destabilizing Modal "Bubbles"
- Achieve Near Colocated Performance

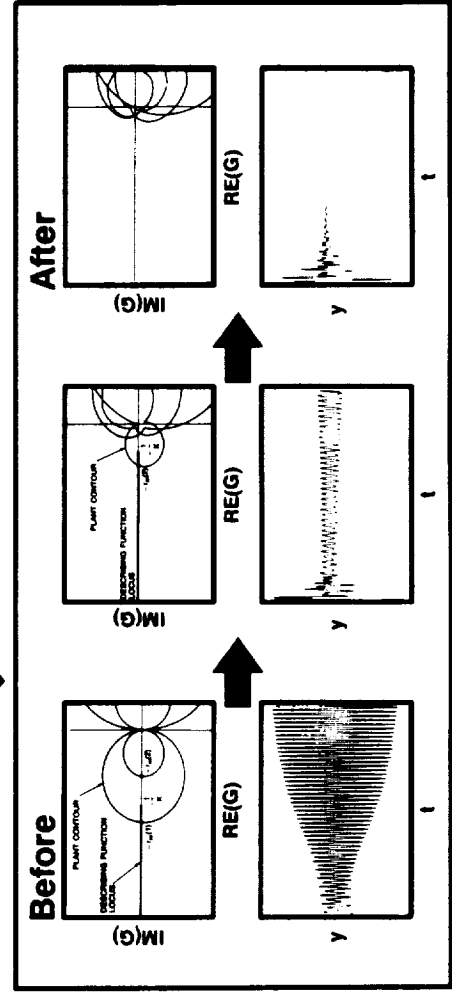

## Advanced Image Processors

---

The objective of this task is to develop and demonstrate efficient algorithms for real-time extraction of geophysical/biophysical parameters from imaging spectrometer and other high-rate imaging instrument data streams, and to carry out design evaluation and demonstration of prototype hardware processing architectures for implementation of these algorithms.

In cooperation with representative remote sensing science users of imaging spectrometer data, efficient algorithms for extraction of specific geophysical/biophysical parameters are being developed and validated with aircraft imaging spectrometer data sets. This group of science users is also providing direct input-specific functional requirements for on-board processing of high-rate imaging instrument data. The hardware architecture issue is being addressed through the use of state-of-the-art commercial board-level multiprocessor computing products. This approach takes advantage of the rapidly developing commercial applications of very high speed computational chip technology, and provides a cost-effective means for arriving at candidate architecture/processor technology for flight implementation within the next 3 to 4 years. Two, or possibly three, iterations of architecture/processor evaluations are planned over the period of FY 1990 through FY 1993. The activity culminates with a final recommendation for a specific architecture/processor combination for applications to flight missions requiring high-rate processing of multiparameter imaging instrument data, such as imaging spectrometers, and demonstrations of the functional capabilities of the candidate system.

The initial "high-water" benchmark functional requirement is the computational intensive problem of performing spectral mixing decomposition to provide quantitative assessment of the percent composition of surface constituents on a pixel-by-pixel basis. The first iteration architecture/processor product chosen is a single-board (VME bus compatible) multiprocessor parallel architecture consisting of four AT&T DSP32C digital signal processing (DSP) chips with distributed memory running at 50 MHz with an aggregate processing capability of 100 MFLOPS. The board has been installed in a Sun-4 testbed along with appropriate drivers and a library of analysis routines. A software environment for carrying out test and evaluation of candidate architectures also has been put into place. Initial tests of the first-iteration architecture indicated that this particular product can perform the complete spectral mixing decomposition operation in under 10 msec per pixel processor on input imaging spectrometer data consisting of 32 spectral bands with three principal mineralogical constituents.

### Technical Contact

Jerry E. Solomon, JPL, (818) 354-2722

# Advanced Image Processor

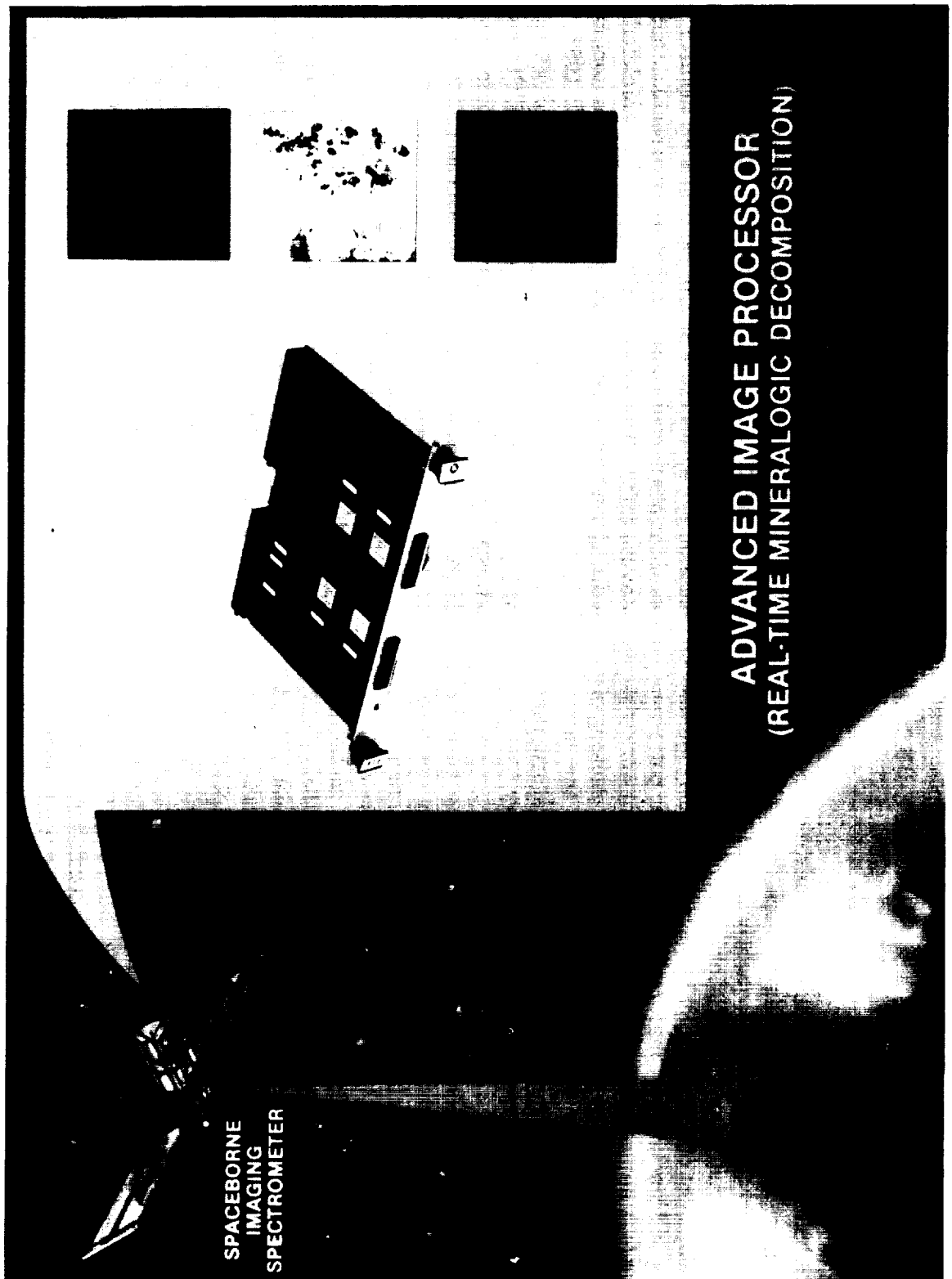

ADVANCED IMAGE PROCESSOR  
(REAL-TIME MINERALOGIC DECOMPOSITION)

## Autonomous Star and Feature Tracking

The objective of this task is to develop advanced optoelectronic tracking and pointing sensors to autonomously identify/recognize and subsequently track features of interest. In particular, the initial objective of this work is the development of a sensor capable of autonomously identifying and tracking the "features" formed by star patterns, i.e., a fully autonomous star tracker. Subsequent work will expand in scope to include identification and tracking of various planetary features and "novelties," the latter representing unusual or suddenly appearing features that fall outside the sensor's catalog of "the ordinary."

Availability of fully autonomous star, and eventually feature trackers, will significantly impact the basic operation of spacecraft and space-based instruments. A more capable star tracker may allow the use of lower performance gyroscopes and might, in some instances, eliminate the need for gyros altogether. More efficient and independent modes of fault/loss-of-attitude recovery, based on identification of any catalog star (rather than just the Sun and Canopus) can be employed. Feature trackers will allow science instruments to be pointed and scanned relative to a point or points of interest rather than inertial coordinates, possibly eliminating the need for tedious mosaicking and overlap matching. Moreover, the instruments can be used more selectively, recording only "novel" information rather than everything in sight and thereby greatly reducing the volume of information that must be transmitted by the spacecraft and subsequently processed on the ground.

During FY 1990, the Autonomous Tracker effort has suc-

cessfully demonstrated identification of a selected (upright) feature against a large and somewhat noisy visual environment. Although decidedly a long way from fully autonomous feature-based tracking, demonstration of this capability represents a promising first step towards recognition of selected planetary features in a realistic optical environment. The Tracker effort has also completed the editing, restructuring, and documenting of an autonomous star-tracking algorithm and code. During FY 1991, this code will be integrated with a sky simulation and eventually with a breadboard charge-coupled device (CCD)-based star-tracker in a demonstration of autonomous star-tracking capability. The resulting baseline tracker system will serve as a point of comparison for future hardware and software developments. Among the most promising of these developments are neural net-based pattern recognition and processing systems. The ability of such systems to rapidly identify patterns based on noisy and/or incomplete information makes them ideal candidates for use in a robust and autonomous star/feature tracker.

### Technical Contact

Randy Bartman, JPL, (818) 354-5320  
Fred Y. Hadaegh, JPL, (818) 354-8777



# Autonomous Star and Feature Tracking

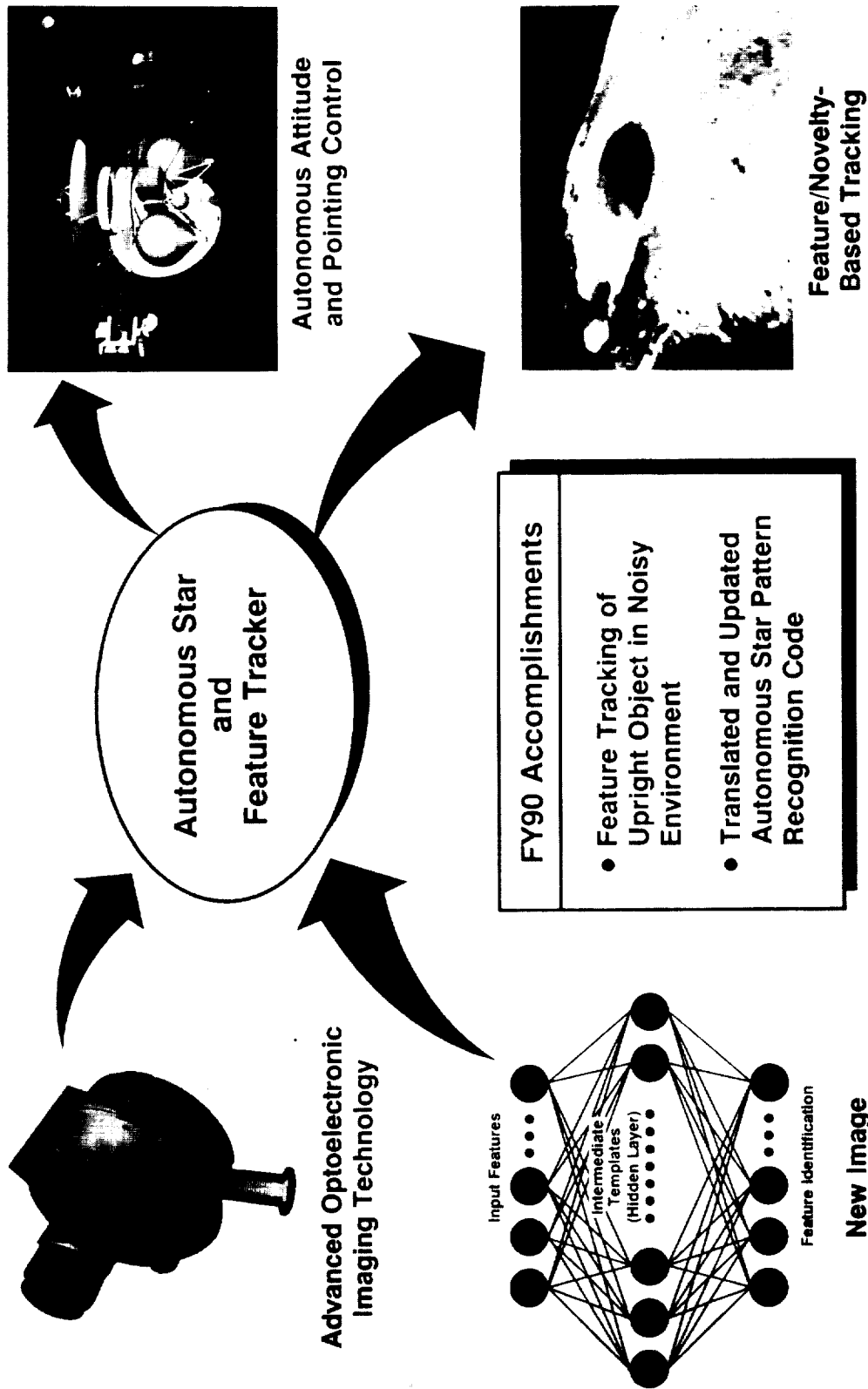

## Fiber Optic Rotation Sensor (FORS)

The objectives of the FORS task are to develop an all-solid-state, navigational-grade inertial rotation sensor for space applications and to transfer this technology to industry.

FORS is based on a phenomenon known as the Sagnac effect: two light waves propagating in opposite directions around a closed path will experience a relative phase shift, the size of which is directly proportional to the product of the area enclosed by the path and the path's inertial rotation rate. This phase shift can be detected and measured by optical interferometric techniques. With the advent of low-loss optical fiber, it has become possible to create a compact sensor capable of resolving very small ( $< 0.01$  degree/hr) rotation rates by winding long lengths of fiber on a relatively small coil form. The enclosed area of the resulting optical path is equal to the product of the number of winds in the coil and the area of the coil and is thus proportional to the product of the total length of the fiber and the diameter of the coil form. The path's large effective area magnifies small rotation rates to produce minute, but nonetheless, measurable phase shifts.

FORS optical source and detectors are high-reliability components developed by the telecommunications industry. The central component of FORS is an integrated optical circuit (IOC), which incorporates the various beam splitters, polarizers, and phase modulators used in FORS onto a single chip, thereby guaranteeing their stable alignment of these components. FORS also incorporates a unique optical signal processing circuit that greatly reduces the overall performance impact of drift and nonlinearity on the sensor's drive and control electronics. Most apparent

in the figure is the overall thermal-mechanical packaging concept used in the FORS brassboard. As in any high-performance inertial sensor, the design and implementation of the sensor package plays a significant role in determining the final performance capabilities of FORS. The FORS brassboard package has been designed by the Charles Stark Draper Laboratory as part of a joint CSDL/JPL effort to develop FORS for use on the CRAF/Cassini mission. The effort, which began in August 1989, is intended to culminate with CSDL's delivery of full four-axis flight units in 1993. During FY 1990, the effort has focused on transfer of the FORS technology to CSDL and fabrication of the brassboard. The latter should be under test by August 1990.

Other organizations are also participating in a FORS technology transfer program. An industry briefing on FORS technology in November 1989, was attended by over 50 engineers and managers representing 35 government and industrial organizations. One major corporation is currently participating in FORS technology transfer, and active discussions are continuing with several other organizations. This transfer effort will continue in FY 1991.

### Technical Contact

Bruce Youmans, JPL, (818) 354-8661

Fred Y. Hadaegh, JPL, (818) 354-8777

## Fiber Optic Rotation Sensor (FORS)

---

### Mock-up of FORS Brassboard

(Package designed by Charles Stark Draper Laboratory  
as part of a NASA / CSDL joint development program)

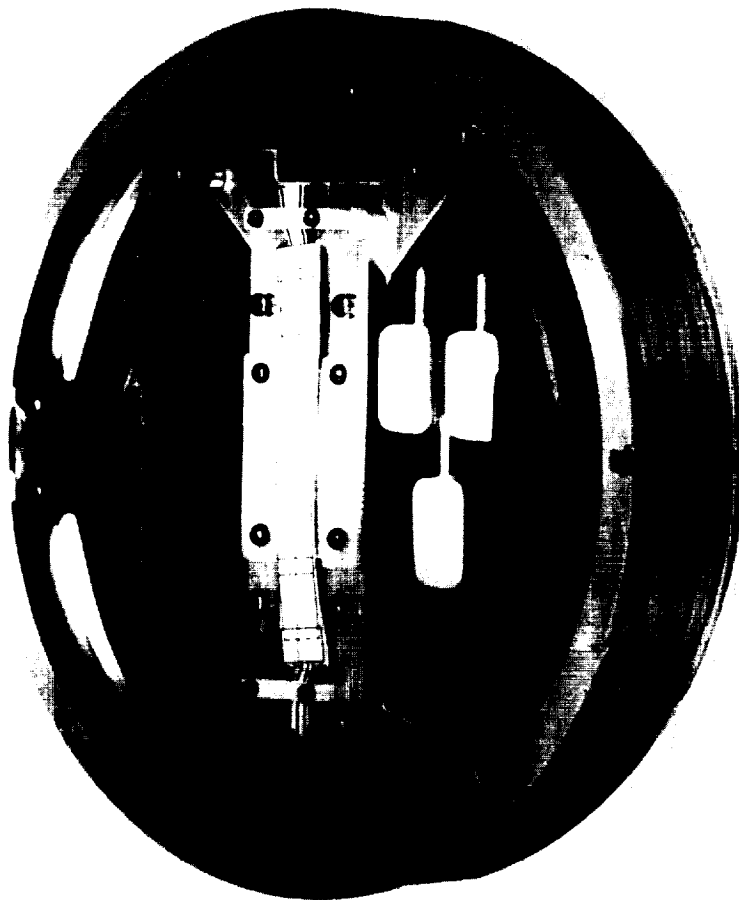

← → ~18 Centimeters → ←

## SHAPES (Spatial, High Accuracy, Position Encoding Sensor)

The objective of this task is to develop a control sensor able to make simultaneous 3-D position measurements of multiple (up to 50) targets. These measurements need to be made with submillimeter accuracy and with a sufficient data bandwidth for system identification, shape, and vibration control of large space structures.

SHAPES, which combines optical angle measurements with time-of-flight range measurements, has the special capability of dynamically tracking many targets simultaneously. The sensor makes use of laser diodes, charge-coupled device (CCD) imaging detectors, and a picosecond-resolution streak tube to provide 3-D position sensing of retroreflector targets. Multitarget tracking capability is required to determine both static and dynamic in-orbit characteristics of large antennas, platforms, and the Space Station. SHAPES measurements can be used to check structural alignment and overall geometry during each assembly phase of the Space Station to verify correct assembly. The SHAPES technology can also be used to determine absolute payload pointing/position from navigational base reference position measurements. In addition, a derivative of SHAPES could be used as a rendezvous and docking sensor at ranges up to 40 km.

The principal accomplishments of FY 1990 were the completion of the 3-D breadboard fabrication and the integration and test of the range and angular measurement functions. The figure shows the angular position camera with a custom, wide-angle, 14 mm F/14 lens mounted with the ranging remote optical head. The return optical pulses are transmitted to the streak tube camera by optical fibers.

The breadboard includes a multiprocessor data acquisition and experiment control system, which is not shown. The sensor measures the 3-D position of 24 targets with a resolution of 0.1 mm in range and 0.05 mrad in angular position over a 32-degree field of view at a data update rate of 10 Hz. Two-phase and dual-frequency operation of the streak tube allows unambiguous range measurement to a range of 50 mm at the design accuracy. A test facility was designed for detailed characteristics of the sensor.

Completion of the detailed characterization and transfer of the technology to industry will be accomplished in FY 1991.

### Technical Contact

Noble Nerheim, JPL, (818) 354-2547

Fred Y. Hadaegh, JPL, (818) 354-8777

# SHAPES: Spatial, High-Accuracy, Position Encoding Sensor



## Payoffs

- Sensing for Static Shape and Dynamic Control of Large Structures
- Payload Pointing

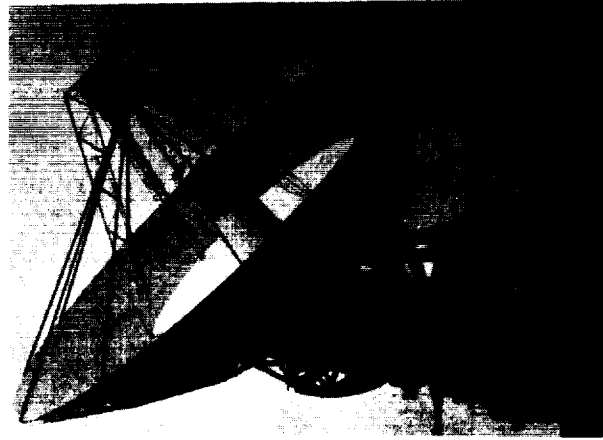

## Accomplishments

- Completed Fabrication of 3-D Breadboard Hardware Components
- Completed Multi-Processor Data Acquisition and Experiment Control System
- Integrated Range and Angular Measurements

## Coherent Launchsite Atmospheric Wind Sounder (CLAWS) Feasibility/Benefit Study

The effort assessed the cost and technological timeliness of using a pulsed Doppler Lidar (Light Detection and Ranging) wind profiler to obtain accurate launch corridor wind profiles in real time, in support of Shuttle and unmanned booster guidance.

Several candidate Lidar sensor configurations were postulated, and their performance was assessed via end-to-end Monte Carlo simulations. In parallel, high-level Lidar guidance sensor models were proposed and used in a trade study that examined the impact on mission availability and performance of variations in sensor range and accuracy. Both ground-based and on-board sensors were considered. A currently feasible ground-based solid-state CLAWS sensor can provide accurate real-time wind profiles for guidance in any normal flight weather; an on-board system would be necessary for flight in rain or very heavy cloud cover. This latter situation might arise in emergency, or high-priority military missions.

Solid-state CLAWS systems, such as those studied in this activity, can virtually eliminate spurious wind-related launch delays. The technology currently exists to support these systems at reasonable cost.

The practical impact of this study is growing. The findings have motivated follow-on, ground-based hardware demonstration activities supported by the Advanced Launch System (ALS) and NASA bridging programs. Several launch vehicle contractors have begun examining the use of ground-based and/or on-board sensors under internal research funds. A two-phase hardware demonstration

program will result in a brassboard system capable of supporting launch operations at Kennedy Space Center by 1993.

### Technical Contact

Daniel D. Moerder, LaRC, (804) 864-6495

# On-Board Lidar Wind Sensor Range

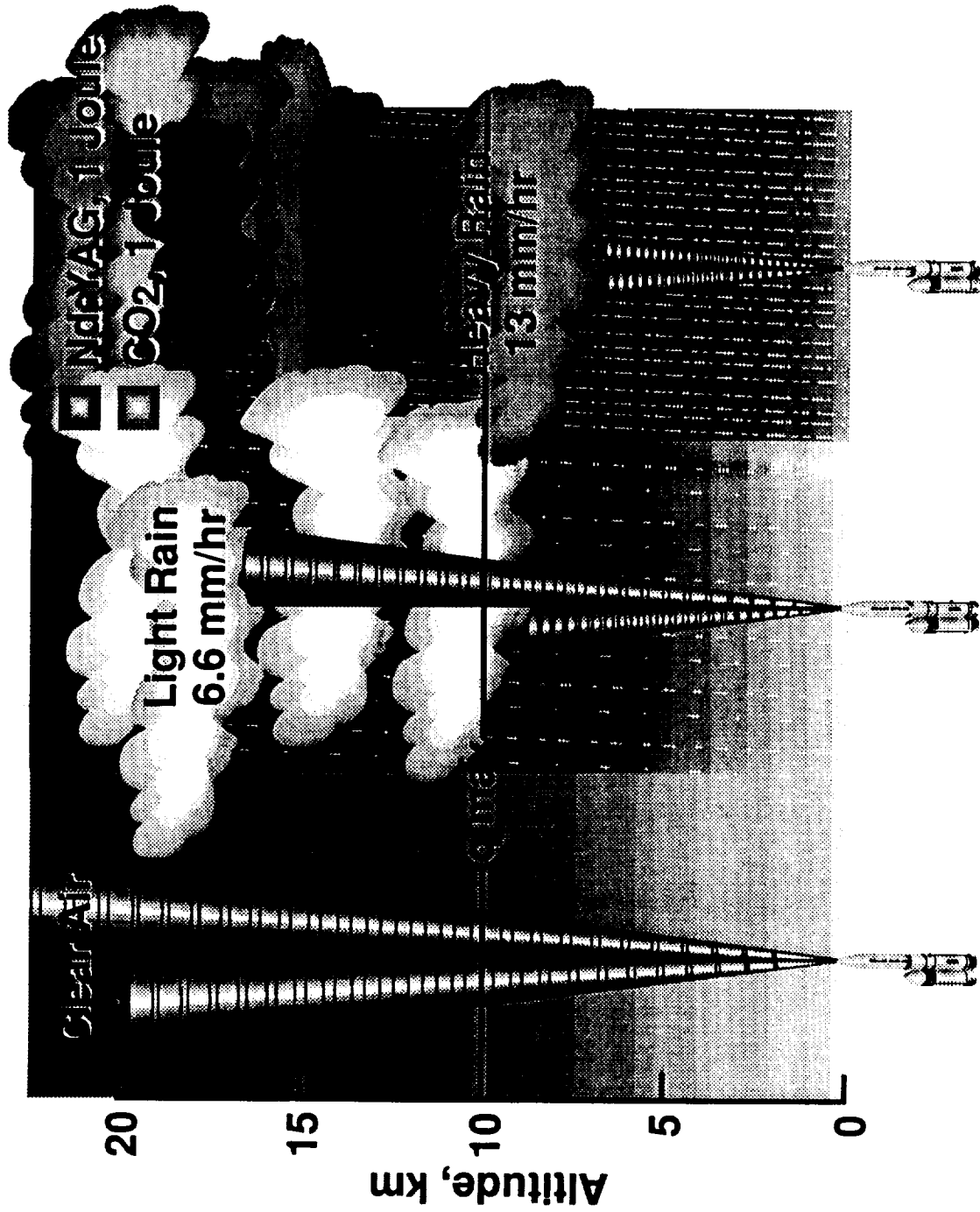

## Closed-Loop Control Test on Mini-Mast

The objective of this research is to develop a high-gain feedback control law for the Mini-Mast and to validate it via simulation and laboratory experiments. A modern control law was designed using the ORACLS design package. It was tested in simulations and then in hardware using the Mini-Mast facility.

Open-loop sinusoidal input tests using the torque-wheel actuators (TWA) were made at resonant frequencies of the structure. Data taken from these tests were processed to identify the resonant frequencies, damping coefficients, and control effectiveness of the actuators. A Linear Quadratic Gaussian (LQG) control law was designed to achieve a 30% damping coefficient at the first resonant frequency. This performance was verified in simulation using the identified resonant frequencies, damping coefficients, and control effectiveness of the actuators. The control law was then tested using the Mini-Mast facility.

The accompanying figure contains time histories of tests on the facility and the pretest simulation. For comparison, the next to the lower trace was taken from an open-loop test run with start conditions as close as possible to those of the closed-loop test. The top trace is the TWA command input in the Y direction. In this test, excitation of the structure was provided by a 30-second sinusoidal input of the y-axis TWA at the first resonant frequency of the structure. The control law was then engaged. The second trace from the top is the output of a noncontacting displacement sensor at the C apex of bay 18 of the Mini-Mast. The effectiveness of the control system in providing damping can be noted by comparing the open-loop test (free

decay) with the same trace in the closed-loop (controlled response).

This was the first closed-loop control test of the Mini-Mast and as such has developed procedures that will profit future guest investigators who may use the facility. This satisfies the FY 1989 planned accomplishment for Mini-Mast Control Law Design. Additionally, it has shown that torque wheels can be effective tools for damping larger flexible structures.

Further tests of this control law on the Mini-Mast are planned to examine the control system response to the flexible modes that the control law was designed to suppress.

Technical Contact

Raymond C. Montgomery, LaRC, (804) 864-6615



# First Active Control Test on Mini-Mast

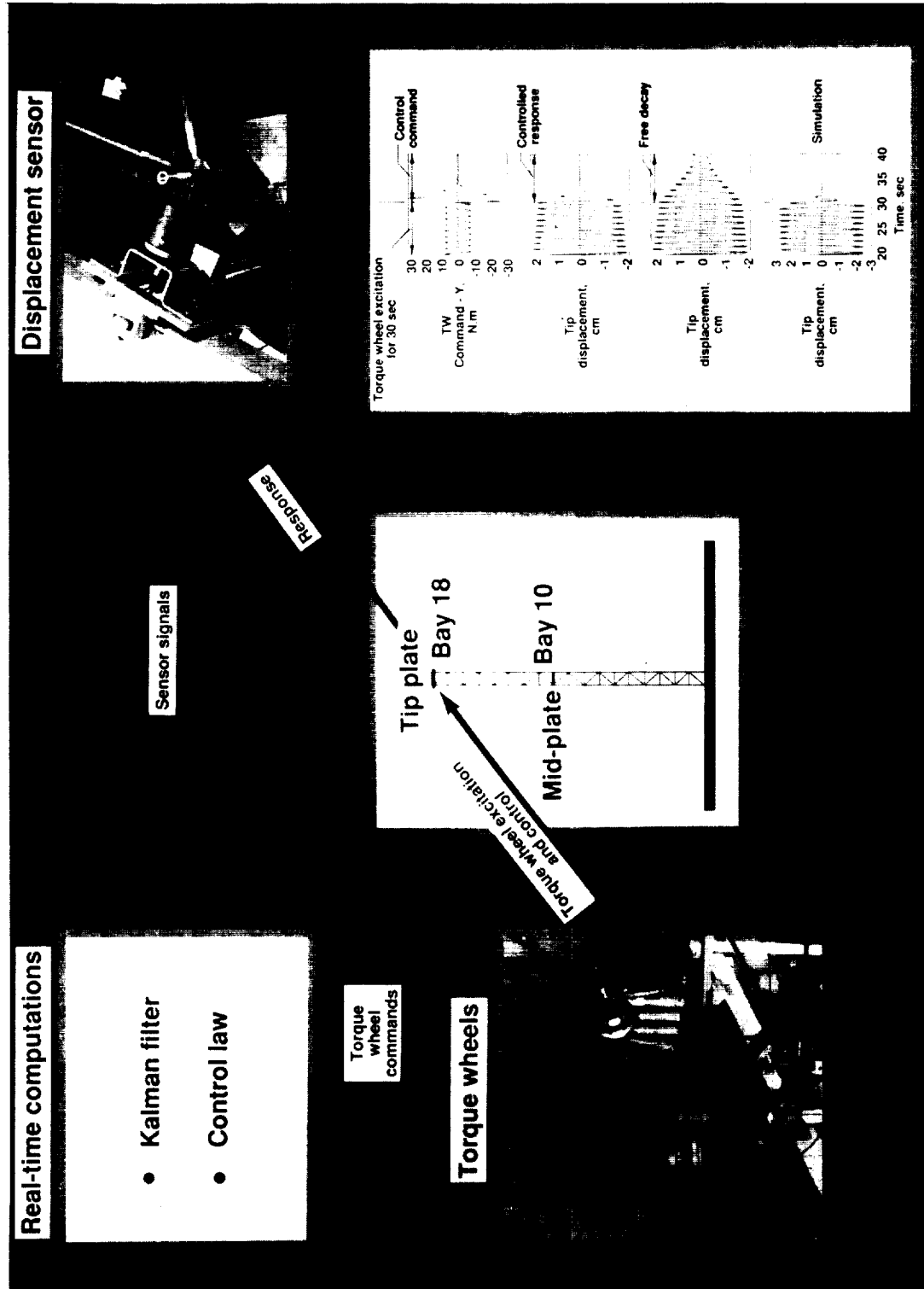

## Personnel Launch System Approach and Landing Simulation Study

The personnel launch system (PLS) concept has been proposed to ferry astronauts to and from a space station using a Titan IV booster for vertical takeoff and performing an unpowered horizontal landing. The reusable vehicle, which could bring a pilotless crew back to Earth under automatic control, is in preliminary design stages. To identify and correct flight control/flying qualities deficiencies early in the conceptual vehicle design process, a piloted simulation study of vehicle approach and landing characteristics has been initiated using the Langley Terminal Systems Research Vehicle (TSRV) simulation cockpit. The objectives are to identify potentially beneficial vehicle configuration improvements, to define candidate control laws, and to investigate a range of landing techniques using both manual and automatic control modes.

A subsonic aerodynamic model was developed from wind tunnel tests of the vehicle with appropriate corrections for landing gear and ground effects. Manual and autoland control laws and a flight director display concept were developed. The 6DOF nonlinear vehicle model was installed and validated on the TSRV fixed-base simulator. An approach trajectory consisting of a steep constant velocity outer glideslope, a constant "g" preflare, and a shallow inner glideslope to precision landing was developed for piloted and autoland control evaluation. LaRC and DFRC research pilots and JSC astronauts will conduct evaluations of the manual control system and of switching transients during manual takeovers from the autoland system. In addition, vehicle performance concerns, such as landing speeds, touchdown sink rates, crosswind capability, and required runway lengths are being studied.

Successful manual landings using both the flight director display and instrument-only approach techniques, under no wind, headwind, tailwind, and steady crosswind conditions were accomplished. The flight director display was shown to lower the touchdown dispersion by roughly 50%, and to lower the touchdown sink rates from an average 8 ft/sec to less than 5 ft/sec. Also, successful landings were demonstrated with early versions of an autoland system under the same conditions. Test pilots and astronauts rate the vehicle handling qualities satisfactory on the outer glideslope. However, because of rapid deceleration during flare on the inner glideslope, they suggest that vehicle design modifications should be investigated to increase the low lift-to-drag (L/D) ratio. Cursorry parametric studies of L/D have indicated that ratings could be improved from acceptable to satisfactory through fairly small L/D increases. Modifications to the flight control configuration and landing gear design were also based on these results.

Early evaluation of a conceptual PLS vehicle design has identified handling qualities/flight control problems. Basic modifications to the vehicle configuration have been identified. LaRC and DFRC research pilots and JSC astronauts are participating in parametric studies of variations in vehicle weight and L/D and flight control issues on landing performance. The simulation will be moved to the Visual Motion Simulator during late summer 1990.

Technical Contact

E. Bruce Jackson, LaRC, (804) 864-4013

# PLS Approach and Landing Simulation Study

PLS Vehicle - Tail Strike and Flare View Angles

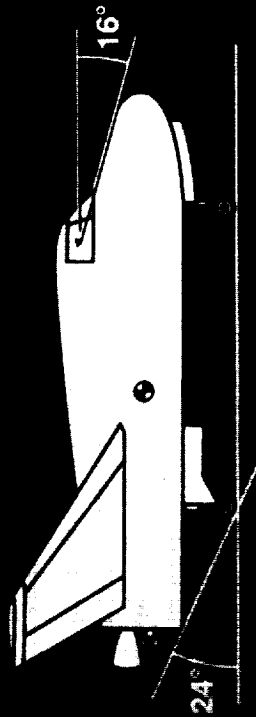

- Subsonic aero model developed from wind tunnel data
- Stability augmentation added to improve handling qualities
- Visual landings demonstrated
- Flight directory display developed
- Parametric study underway



PLS Subsonic Lift to Drag Ratio

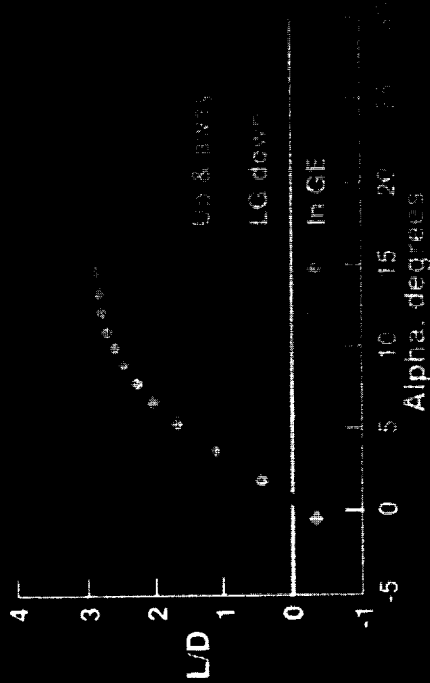

PLS approach & landing trajectory



## Advanced Control Evaluation for Structures (ACES) and Computational Control

---

The objectives of this program are to develop, test, and verify advanced control techniques on a large, complex space system and to effect modeling and control methods that are computationally efficient and repeat the test and verification process for these methodologies.

The control technology program (ACES-II) was conducted in the ACES-I laboratory environment, which has a large complex space system with 17 sensors, 9 effectors, and a series of computers, in which the advanced control algorithms are housed and are used to close the loop between the sensors and effectors. Four control techniques, Positivity, Decentralized Pole Placement (DPP), High Authority Control/Low Authority Control (HAC/LAC), and Model Error Sensitivity Suppression (MESS), were tested in the ACES-I laboratory. Previously, these control methods had only been evaluated analytically and not verified in a complex hardware environment. With the ACES facility, control verification can be effected using time response techniques, frequency response methods, robustness analysis, and failure mode analysis. Also, in the computational control area, modeling tools are being enhanced (TREETOPS improvements) and a control methodology is being developed that precludes the necessity of solving large order, simultaneous, nonlinear matrix equations. Once these computational control elements are effected, these elements will be tested and verified in the ACES-I laboratory and the newly developed Multibody Modeling Verification and Control Lab Complex.

In the ACES-II program, frequency response analysis, robust analysis, and failure mode analysis were performed

on Positivity, DPP, HAC/LAC, and MESS. Based upon the ACES-I control synthesis, all the control methods had their positive and negative points, but the method with the most positive points was DPP.

### Technical Contact

Henry B. Waites, MSFC, (205) 544-1441

# Advanced Control Evaluation for Structures (ACES) - II

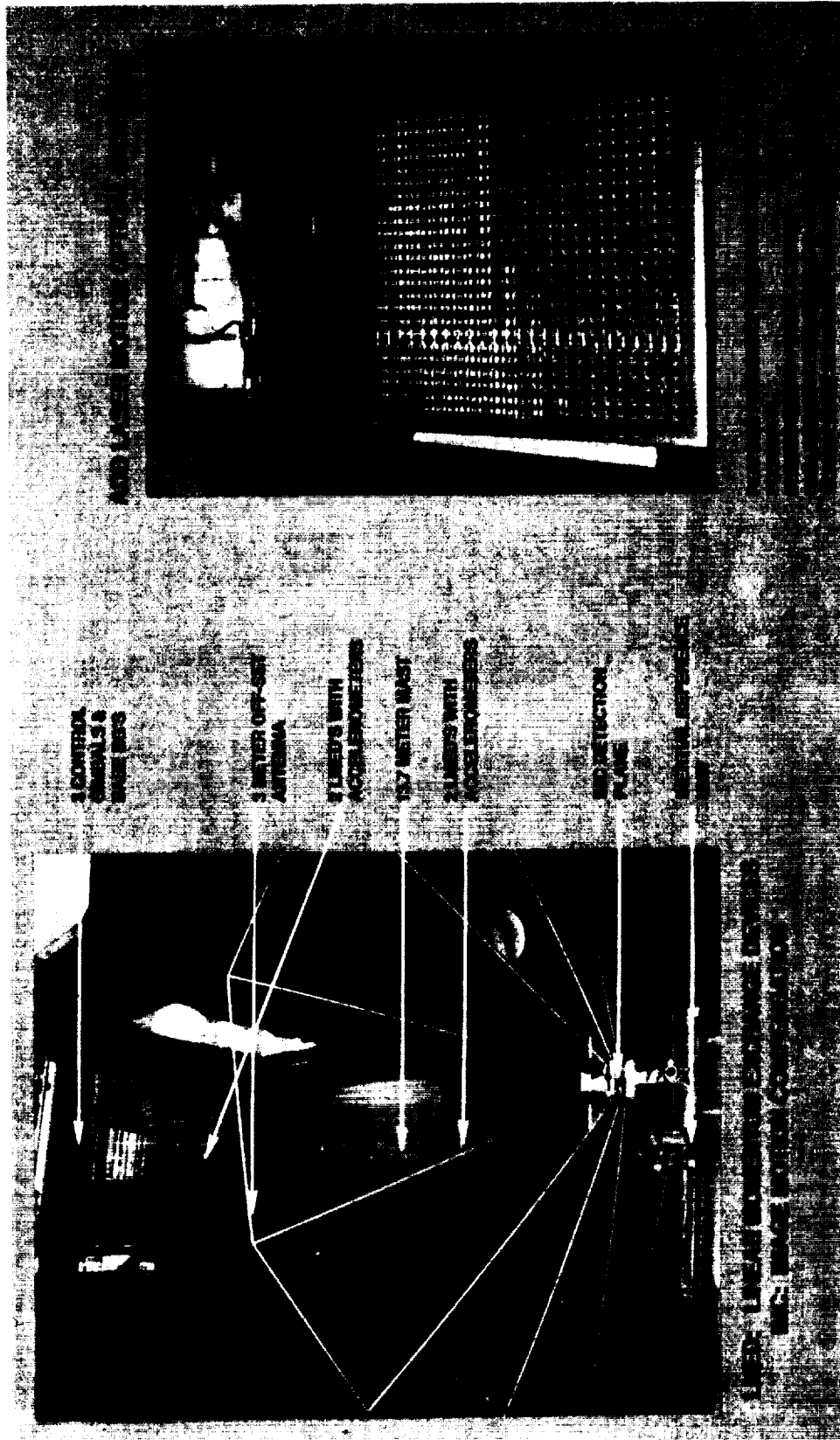

ORIGINAL PAGE OF POOR QUALITY

ORIGINAL PAGE BLACK AND WHITE PHOTOGRAPH

## Autonomous Rendezvous and Docking

The objective of this effort is to define, develop, and evaluate autonomous rendezvous and docking guidance and control algorithms for planetary and lunar mission applications using input from one or more navigation sensors.

The study was conducted using the MFSC air-bearing vehicle (ABV) and flat-floor facility. A charged-couple device (CCD) based sensor was used to track a three-point docking target illuminated by 10 laser diodes. This sensor provides the coordinates of the three points in the field-of-view; an inverse-perspective algorithm is used to compute relative states in the chase vehicle reference frame. Six independent control channels are used to generate thruster commands for the X, Y, Z, roll, pitch, and yaw axes. Each channel consists of a proportional-derivative controller with rate-limiting capability. This technique was fully validated using the ABV to simulate the chase vehicle and a Hubble Space Telescope (HST) model as the target vehicle. The ABV has acceleration capabilities that are representative of estimated planetary spacecraft reaction control system capabilities. The HST model is coated with reflective multi-layer insulation, which potentially causes reflections and mistracking.

Numerous tests of this system were conducted in FY 1989 and FY 1990, which resulted in considerable refinement and upgrading of the technology. The result was a system capable of tracking the target from as far away as 150 feet, in the presence of ambient light and spurious reflections from the multilayer insulation. A docking success rate of virtually 100% was obtained, using docking latches requir-

ing plus or minus two degrees and plus or minus two inches of alignment accuracy. All of the system components are low-cost off-the-shelf items, including the CCD sensor and 80386/80387 based computer.

### Technical Contact

Richard Dabney, MSFC/ED13, (205) 544-1473

Ricky Howard, MSFC/EB24, (205) 544-3536

Mike Book, MSFC/EB24, (205) 544-3699

**Charged-Couple Device (CCD) Based Sensor**



ORIGINAL PAGE IS  
OF POOR QUALITY

ORIGINAL PAGE  
BLACK AND WHITE PHOTOGRAPH





## **Data Systems**

The Data Systems Program consists of research and technology devoted to controlling, processing, storing, manipulating, and analyzing space-derived data. The objectives of the program are to provide the technology advancements needed to enable affordable utilization of space-derived data, to increase substantially the capability for future missions of on-board processing and recording and to provide high-speed, high-volume computational systems that are anticipated for missions such as the evolutionary Space Station and Earth Observing System.

The Data Systems Program supports fundamental research in such areas as laser diodes, supports work to select and provide the appropriate on-board processor technology for future NASA missions, and also supports the development of two flight processors with special architectures. The ongoing support for solid-state laser research leads directly to the development of a nine laser diode array that is used in the Optical Disk Recorder. Some laser research efforts are focusing on Space Station data handling applications. These devices are being developed to handle both the 300 Mbit/sec basic data rate and the much higher rates needed to support networking and computer internal communications. Complementary research is being supported to characterize the fundamental performance and properties of various alternative networking.

NASA missions require processors that will work very reliably in the space environment. Computer systems for missions in polar orbit and some planetary missions must operate reliably in high radiation environments. The Data Systems Program capitalizes on the dramatic advances in electronics, computer systems, and software that are occurring in both the public and private sectors. It fosters and leads the development of technologies required to meet NASA's unique data systems needs. NASA technical expertise is being applied in cooperative arrangements with DoD, and products from the DoD VHSIC program and other DoD developments are being assembled into processors for testing and evaluation.

The Advanced Digital Synthetic Aperture Radar (SAR) Processor includes a special architecture and algorithms to process SAR data. The unit will have a compute rate of 6000 megaflops per second. The Massively Parallel Processor (MPP) is being used for ground processing of space image data, SAR data, and spectral analysis. The MPP utilizes 16,384 processors. The research applications developed on the MPP have verified the expected tremendous computational power of the MPP for the target applications. Researchers outside of NASA in several universities, research centers, and industry have been given access to the MPP to gain an understanding of its capabilities, and they have applied these unique resources to a broad range of computational problems.

Future objectives through the Civil Space Technology Initiative in High Rate/High Capacity Data include data system architectural studies for new space initiatives, significant advances in technologies and capabilities for on-board image processing, data compression, high-volume block access storage, data networks, spectrometry, and adaptive sensor control.

Program Manager: Paul Hunter  
NASA/OAET/RC  
Washington, DC 20546  
(202)453-2704

## Algorithms/Applications – FY90 Configurable High-Rate Processor System (CHRPS)

The focus of this program is to develop and demonstrate algorithms and applications that can exploit, in Earth orbit, the high-capacity processing capabilities provided by Configurable High Rate Processor System (CHRPS). These algorithms are generally categorized as data compression and data analysis. We plan to demonstrate that the CHRPS concept will allow scientists, from their laboratory, to program and control on-board high-rate processing and receive only the meaningful results at their workstations.

In FY 1990, this task developed a lossless data compression package that provides a selection of compression algorithms from which a user can choose the one most appropriate to the data set at hand. This package was presented to the National Space Science Data Center (NSSDC) User Group and installed on the NSSDC VAXCluster for experimental use by that user community.

In addition, a multispectral image compression scheme was developed based on region growing and quadtree data structures that compress multispectral images to three different levels: browse, moderate loss, and lossless. Browse resolution results of this scheme are shown on the accompanying illustration in the righthand column. This scheme achieves a 20:1 compression ratio by locating and retaining only the edges of regions and discarding the texture information held within the regions. New schemes retaining different types of information are targeted for development in FY 1991.

The SPAM (Spectral Analysis Manager) software was

installed on the Science Information Systems Center's VAXCluster. Two SPAM analysis approaches, spectral matching and mixture analysis, were selected for FY 1991 use in evaluating the effect of data compression on AVIRIS analyses.

In FY 1991, evaluation of a least three approaches to data compression for AVIRIS data will be performed. Analysis scenarios for use in data compression evaluation of simulated MODIS data will be selected. Three additional algorithms will be added to the baseline (NSSDC) compression package. Evaluation will be performed of at least three approaches to data compression for MODIS data. A report will be prepared comparing results using the baseline (NSSDC) compression package for a wide variety of data set types.

Technical Contact

James C. Tilton, GSFC, (301) 286-9510

# Lossless Data Compression

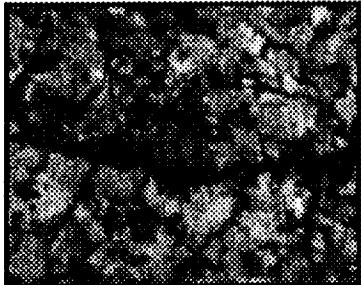
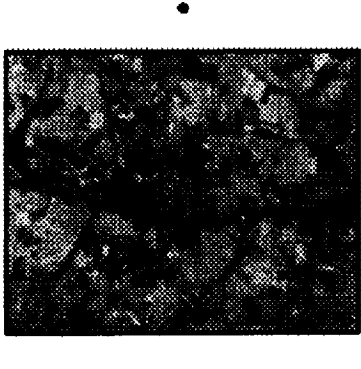
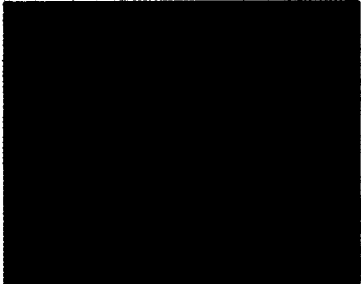
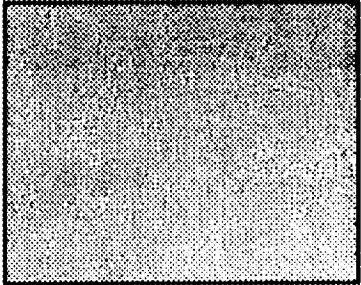
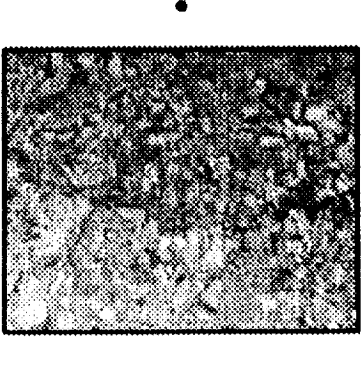
<p>Compressed by <b>UNIX "compress"</b> lossless technique</p>		<p>Compressed by <b>Block Averaging</b> on 4 by 4 Blocks</p>		<p>Compressed by <b>Region Growing</b> delineating statistically similar areas followed by lossless compression</p>		<p>Range of Techniques Tailored to Users Retaining Different Types of Information</p>
<p><b>Data Images</b> <i>Information Retained</i></p>	<p>Compression: 1.7:1 Error: 0.0</p>	<p>Compression: 20.1:1 Error: 0.20</p>	<p>Compression: 21.3:1 Error: 0.29</p>	<p>•••</p>	<p>•••</p>	
<p><b>Difference Images</b> <i>Information Lost</i></p>				<p>•••</p>	<p>•••</p>	
<p>Data is Thematic Mapper Imagery, bands 1-6 from near Ridgely, Maryland Bands 2, 4 &amp; 6 are displayed</p>	<p>Edge information lost Texture information lost</p>		<p>Edge information retained Texture information lost</p>		<p><b>Browse Resolution Images</b> Error is band average Normalized Mean-Square Error (NMSE)</p>	

## Automatic Image Data Encoding and Analysis

Our main objective is to perform fundamental research in automated approaches for encoding multispectral imagery data into image segments based on the spatial structure of the multispectral data and to investigate automated methods for analyzing this encoded data on a segment-by-segment basis. A secondary objective is to develop criteria for evaluating the effectiveness of our analysis approaches on NASA remotely sensed image data.

There are a variety of ways for determining ground reference data for satellite remote sensing data. One of the ways is to photo-interpret low altitude aerial photographs and then digitize the cover types on a digitizing tablet. The resulting ground reference data can then be registered to the satellite image, or, alternatively, the satellite image can be registered to the ground reference data. Unfortunately, there are many opportunities for error when using a digitizing tablet and the resolution of the edges for the ground reference data depends on the spacing of the points selected on the digitizing tablet. One of the consequences of this is that when overlaid on the image, errors and missed detail in the ground reference data become evident. This task developed an approach for correcting these errors and adding detail to the ground reference data through the use of a highly interactive, visually oriented process. This process involves the use of overlaid visual displays of the satellite image data, the ground reference data, and a segmentation of the satellite image data.

Several programs were implemented on the Science Information Systems Center (SISC) VAXCluster and with an IVAS image display system to effect interactive editing of

an edge map from an image segmentation so as to leave only those edges that correspond to boundaries between the ground cover types distinguished by the ground reference file. The resulting refined ground reference file then can be used for more accurate evaluation of new image analysis algorithms.

At the point funding ran out for this task, the interactive line editing programs have been applied to a 128 x 256 pixel portion of a Landsat Thematic Mapper data set, giving excellent results. When more funds become available, this refinement technique will be applied to several other tests' data sets and ground reference files.

### Technical Contact

James C. Tilton, GSFC, (301) 286-9510

# Comprehensive Vision System

- Goddard research focuses:**
- Image Representation, and Image Standards
  - Image Understanding

Comprehensive vision system for two-dimensional, multispectral image data

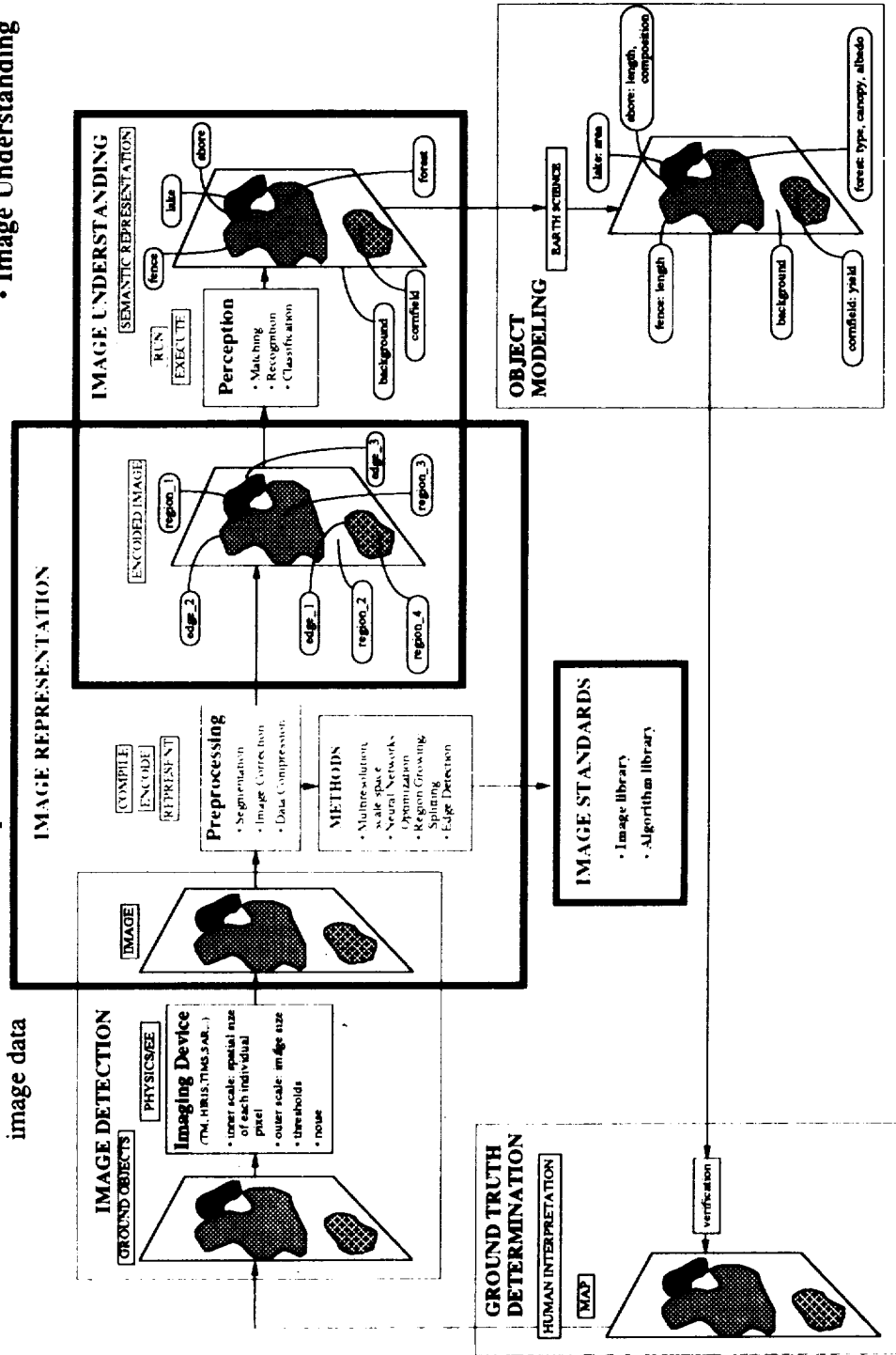

## Configurable High-Rate Processor System (CHRPS)

The goal of the Configurable High-Rate Processor System (CHRPS) is to provide the architecture, system control, and high-rate data handling interfaces needed to support on-board compression, information extraction, and automated operations of high-rate imaging missions.

The next generation of imaging sensors will provide measurement capability at finer spectral and spatial resolutions, resulting in data rates exceeding the capability of the Tracking and Data Relay Satellite System (TDRSS) and exceeding the capacity of ground-processing systems and analysis teams. Interdisciplinary studies will require coordinated observations and integrated analysis of data from these sensors. The CSTI Data System Program is developing image processing and optical disk recorder technology to support on-board data compression, information extraction, and data buffering for these high-rate missions.

The objective of CHRPS is to apply high-rate network technology and develop the packet telemetry handling interfaces to enable the processing and buffering components to be configured for a range of operations from single instrument data compression to multisensor fusion and feature extraction. The CHRPS development will produce a phased testbed to demonstrate technology components for project applications such as EOS to support the integration of technology into space platform architectures and to support the evaluation of on-board processing functions. Support is building within NASA and the DoD to use the CHRPS testbed as a technology demonstration resource.

During FY 1990, the two contract study teams preparing Phase-B designs for the EOS Data/Information System completed special emphasis studies defining project requirements for high-capacity processing on board the EOS platforms. Generation of high-level data products for direct broadcast to low-cost ground stations emerged from these studies as the prime subject of interest to the EOS Project because EOS may fly direct broadcast on POP-A but with no processing or storage. The EOS Project stated that Code R activity (to develop prototype and demonstrate enhancing technologies in support of the direct broadcast capability) will make significant contributions to the EOS Project, if requested funding levels are approved.

In FY 1991 we will develop and refine scenarios for on-board data product computation in support of the EOS direct broadcast capability. This activity will be performed in collaboration with the EOS Project and will be used as an avenue to achieve continued visibility of the concept within the EOS Project.

Technical Contact

Dan Dalton, GSFC, (301) 286-5659

# CHRPS Architecture

## CHRPS Onboard Concept

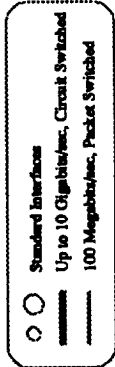
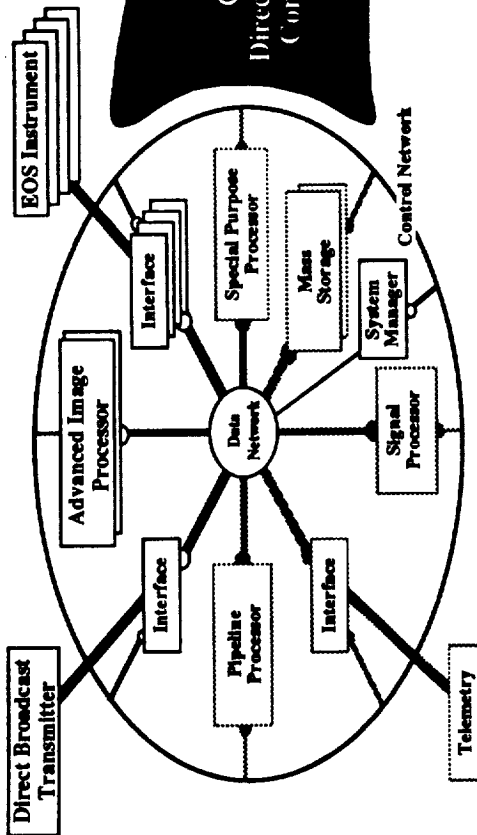

Onboard processing and storage can be used on EOS Platforms to generate high level data products for direct broadcast to low cost ground stations.

### Enables:

- Modestly equipped ground stations
- More products to the ground
- Evolvable products



EOS Testbed



CHRPS Direct Broadcast Testbed

The Direct Broadcast testbed develops and demonstrates complex real-time functionality:

- Depacketization
- Level 0 processing
- Level 1 processing
- Simultaneous formation of multiple products
- Packetization and coding for downlink

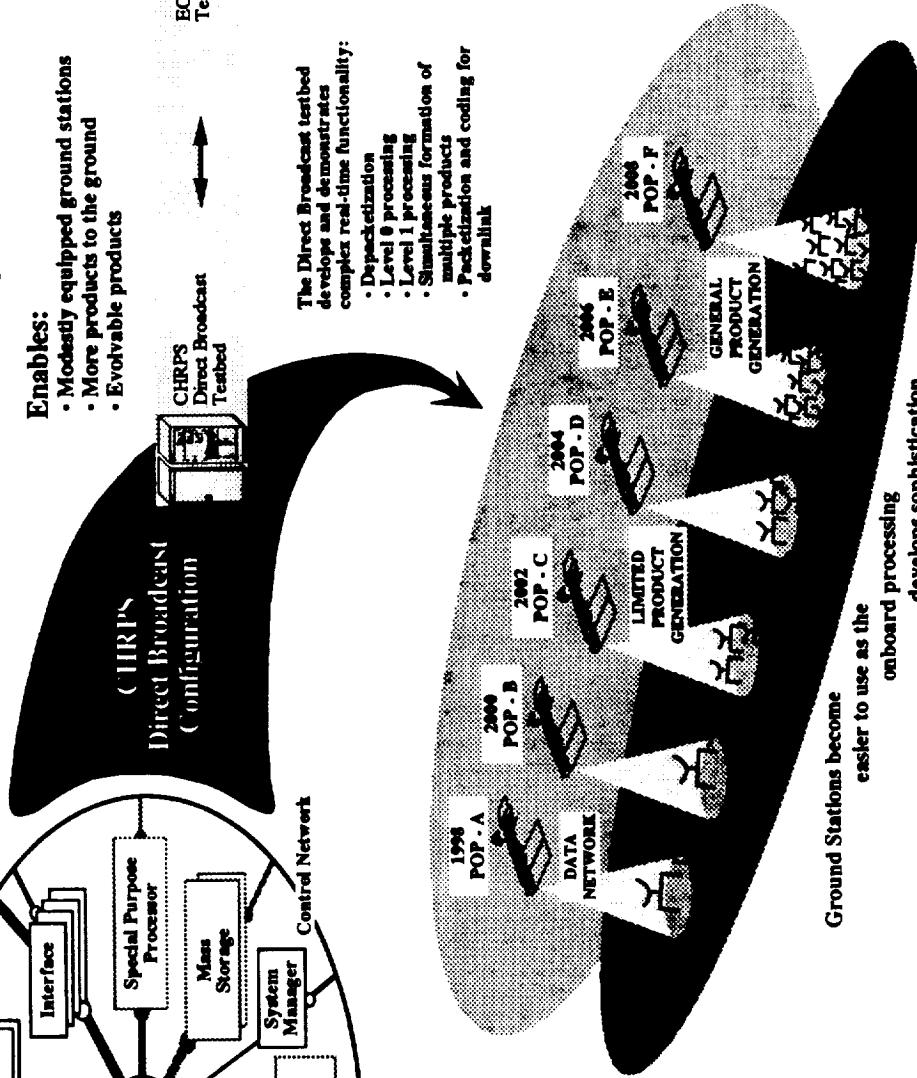

Ground Stations become easier to use as the onboard processing develops sophistication.

## Gallium Arsenide (GaAs) Pipeline Processor

The objective of this program is to advance on-board ultrahigh-speed data acquisition and processing of scientific data. The Earth Observatory Spacecraft/Geodynamics Laser Ranging System (EOS/GLRS) scientific requirement is to acquire data in "snapshots" at rates up to 12 billion bits per second and to preprocess data on board prior to transmission to ground using radiation hard, low-power integrated circuit technology. The solution lies in a pipeline processor architecture implemented in high-speed GaAs technology.

NASA and the Office of Naval Research (ONR) initiated a program with Rockwell International for the development of an advanced, Ultrahigh-Speed Data Acquisition (USDA) system. This system will be capable of digitizing an incoming analog signal at 8-bit resolution and a sampling rate of 1.5 giga-samples per second, storing the resulting digital information for a period of 1.4 msec, and upon command, reading out the stored information at a rate compatible with the pipeline data processing hardware. The high-speed data acquisition system addresses an immediate need within NASA for data recording in the GLRS. It also addresses generic requirements within the Navy, particularly in providing the basis for flexible, affordable, light weight, satellite-based electronic systems with advanced capabilities. The ultrahigh-speed electronics technologies developed in this program are key technologies for advanced communication systems, high bandwidth remote sensing and signal processing, and high-rate data processing.

Development of High Electron Mobility Transistor (HEMT) memory circuits has been proceeding at Rockwell under ONR/NASA sponsorship. This effort has led to the demonstration (in FY 1990) of fully functional 1K Random Access Memory (RAM) and 99.8% functional 4K RAMs with ultrahigh-speed (read access time down to 0.6 nsec) and low power (chip power of 0.3 W for 1K RAM), with an access time of 2.0 nsec. Also, in FY 1990 the University of Idaho completed the architecture design of a general purpose pipeline processor which uses a reconfigurable data path processing chain.

### Technical Contact

Warner H. Miller, GSFC, (301) 286-8183



# GaAs Pipeline Processor

## NASA POTENTIAL USERS:

GEODYNAMIC LASER RANGING SYSTEM  
DIGITAL AUTO-CORRELATION SPECTROMETER  
DSN / DIGITAL RECEIVER

## PARTICIPANTS:

OFFICE OF NAVAL RESEARCH  
ROCKWELL IRD  
NASA

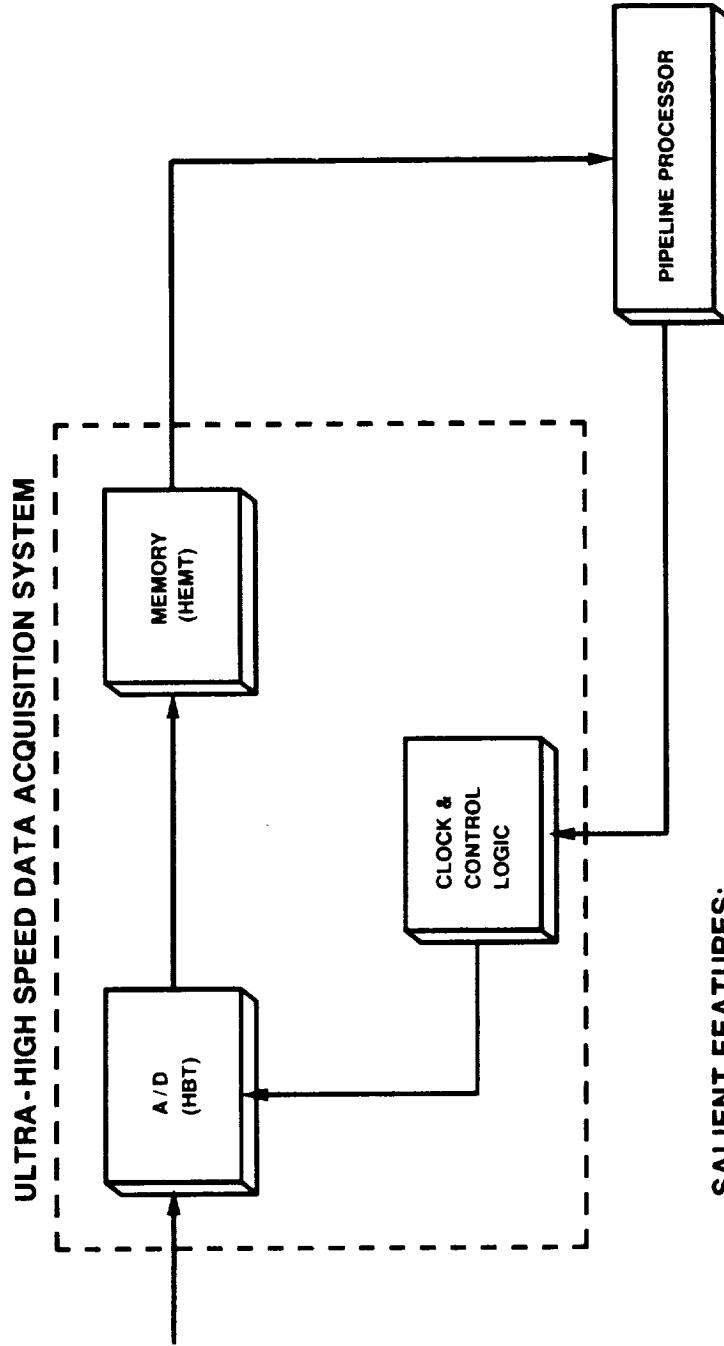

## SALIENT FEATURES:

DIGITIZATION RATE: 1500 MILLION SAMPLES PER SEC. AT 8 BITS PER SAMPLE  
STORAGE PERIOD: INCREMENTS OF 1.4 MICRO-SEC.  
POWER: LESS THAN 15 WATTS

## SIMD CHIP – FY90 Configurable High Rate Processor System (CHRPS)

The objective of this research is to demonstrate the feasibility of a flight-qualified compute engine able to sustain at least one gigaflop per second when performing data compression and image analysis algorithms.

Most data compression and image analysis algorithms including synthetic aperture radar signal processing can be readily performed by computers with a very large number of processing elements controlled by a main control unit. This type of computer architecture is generally called the Single-Instruction-stream Multiple-Data-stream (SIMD) architecture. The SIMD architecture is a good match to applications that involve massive numbers of data elements, all being processed in a similar manner. It is inherently more energy efficient than any other parallel computer architecture since only one controller and one program memory are required to control a massive number of processors.

In FY 1990, the Microelectronics Center of North Carolina (MCNC), operating under a second year NASA grant, designed, fabricated, and demonstrated on a test board a fully functional custom CMOS integrated circuit containing 128 processing elements implemented with 1,109,340 transistors. A rad-hard version of this chip is the basic building block of a massively parallel gigaflop compute node.

In FY 1991, we will contract with AT&T Bell Laboratories to define the approach, schedule, and cost to produce a rad-hard version of the MCNC chip.

We will explore the establishment of collaborations with several Earth scientists and astrophysicists involving application of a high rate processor to address their upcoming requirements. Candidate areas are prototype Earth Observing System (EOS) instrument testing in aircraft, EOS direct readout data product formation in space, and Hubble Space Telescope (HST) third generation instrument imbedded processing. We will derive requirements and detailed scenarios based on a network architecture or an imbedded processor to express their requirements.

We will initiate design of a scalable prototype system incorporating the MCNC chip component to address the processing and data handling requirements derived from the above mentioned collaborations. Options for packaging such a prototype system include high-density approaches such as the stacked silicon modules being developed by Irvine Sensors, and the thermal conduction unit being developed by MCNC.

Technical Contact  
James Fischer, GSFC, (301) 286-3465

# SIMD Chip

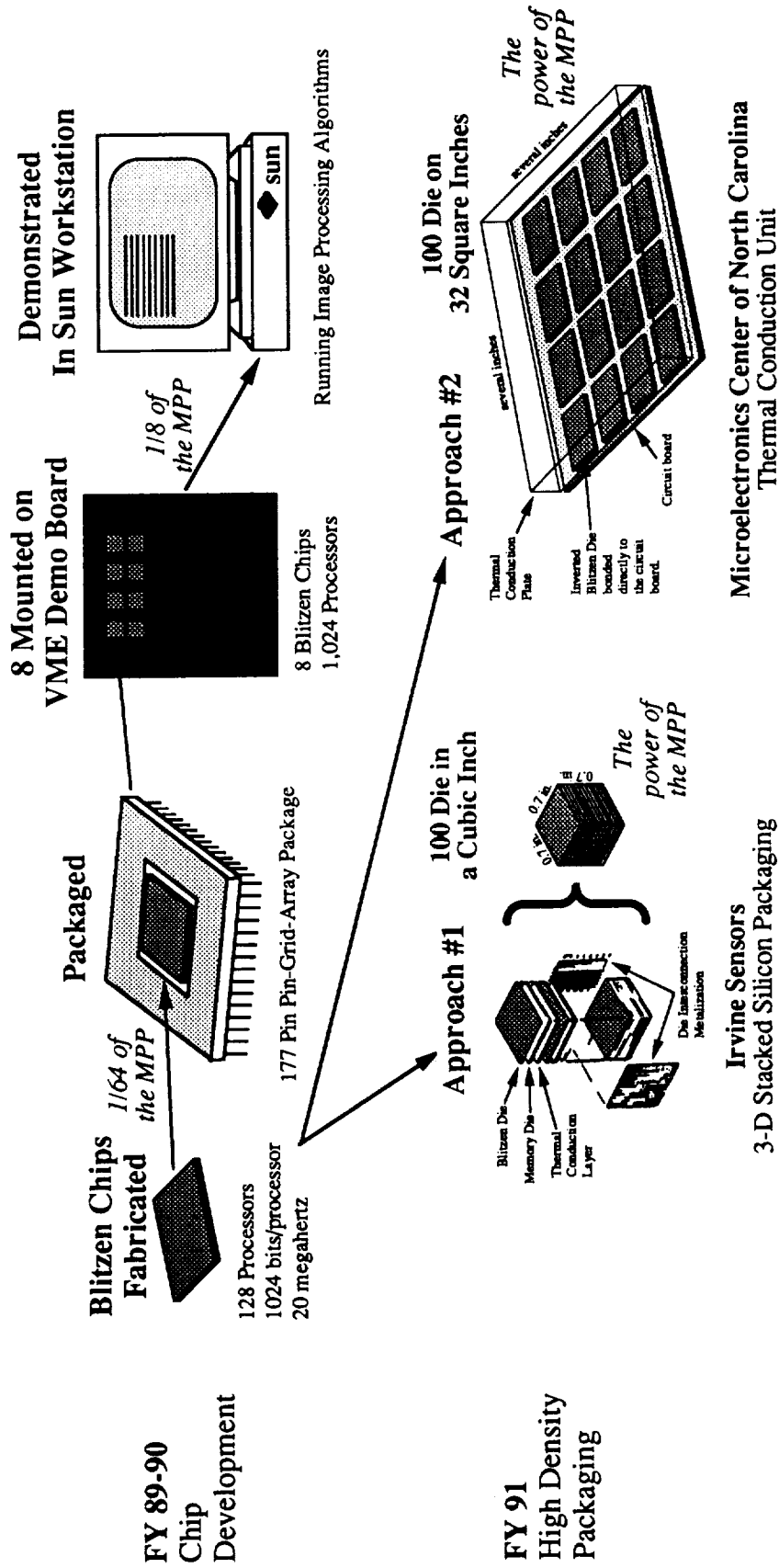

- FY 91**  
High Density Packaging
- FY 92**  
Utilization
- Enable accelerated development time tables for prototype EOS instruments**
- Collaborate with two Earth scientists developing prototype imaging sensors
  - Demonstrate high speed processor systems performing realtime data processing in their aircraft onboard data systems.

## Source Encoding (Lossless Data Compression)

The objective of this program is to develop source encoding technology to maximize information return from science instruments on space platforms by reducing the requirements for on-board storage and/or channel communication bandwidth.

High resolution imaging science instruments in conjunction with large space platforms are driving the telemetry bandwidth requirements to exceed what is currently available in the NASA Tracking and Data Relay Satellite System (TDRSS). As a result of the TDRSS bandwidth constraints some form of on-board processing is required to reduce the science instrument data rate. In addition, by reducing the science data rate additional information can be stored on the on-board tape recorder prior to playback through the telemetry channel. In the past, lossless data reduction was mostly implemented with the well-known Huffman code, an optimal source coding scheme for known data statistics which determines the code book. The code book assigns shorted code words to source samples occurring more frequently and longer code words to less-frequent samples. From our analysis at GSFC we have established that the Rice coding scheme is a collection of Huffman codes designed at various entropy ranges, without the need to store any code book. The major advantage of Rice's coding scheme is its simple coding structure, which lends itself easily to hardware implementation.

Completed in FY 1990 was a Very Large Scale Integration (VLSI) logic design of a multiuser source coder and decompressor chip set at the University of Idaho. The source coder is adaptive to source statistics and can oper-

ate at data rates up to 10M samples per second. Also completed were data compression simulations (based on the VLSI design algorithm) for both imaging and nonimaging science data sets. These simulations included data generated by the following instruments: Michelson Doppler imager/SOHO, NRL and Lockheed instruments on Orbiting Solar Laboratory (OSL), and Lunar Gamma-Ray Spectrometer. Initiated in FY 1990 was a design of a Configurable High-Rate Processor (CHRP) testbed Image Instrument Simulator (IIS) with data compression capability. The IIS will generate imaging data, compress the data, format the data into variable length packets, and deliver the data to the CHRP testbed. This testbed will be used with TDRSS to demonstrate lossless image data compression.

Technical Contact

Warner H. Miller, GSFC, (301) 286-8183

# Source Encoding

**VLSI TECHNOLOGY**  
HIGH SPEED - UP TO 10 MEGA SAMPLES PER SEC.  
LOW POWER - LESS THAN 1 WATT  
RADIATION HARD - GREATER THAN 100 KRAD

**POTENTIAL USERS**  
SOHO - MICHELSON DOPPLER IMAGER  
OSL - HIGH RESOLUTION TELESCOPE AND SPECTROGRAPH  
- X-RAY/ULTRA VIOLET IMAGER  
- VISIBLE SPECTROGRAPH  
- PHOTOMETRIC FILTERGRAPH  
LUNAR - GAMMA-RAY SPECTROMETER

**EXAMPLE:**  
MULTISPECTRAL IMAGING  
DATA RATE OF 450M BPS  
EXCEEDS TDRSS CAPABILITY

**SOURCE ENCODING  
(LOSSLESS DATA COMPRESSION)**

COMPRESSED MULTISPECTRAL  
IMAGE DATA RATE 225M BPS  
COMPATIBLE WITH TDRSS

**SCIENCE BENEFIT**  
AT LEAST A FACTOR OF 2 INCREASE IN  
ONBOARD & ARCHIVAL STORAGE CAPACITY  
AND TELECOMMUNICATION BANDWIDTH

**FEATURES**  
APPLICABLE TO MULTI USERS BOTH  
IMAGING & NON-IMAGING  
ADAPTIVE TO VARYING SCENE STATISTICS  
NO DISTORTION IN RECONSTRUCTED IMAGE

## Data Storage Technology

---

The purpose of this task is to evaluate the state of magnetoresistive (MR) fixed-tape head technology for achieving high data rate and high-capacity data storage and to identify an attractive method for simultaneously achieving high data rate and high-capacity recording with high reliability, effective data rate matching, and low mass, volume, and power.

The evaluation results indicate that MR head technology is an extremely viable and promising technology, and that storage density using MR head technology is at least three times greater than optical storage densities. Results also indicate that reliability figures using MR heads are one to two orders of magnitude greater than those achieved with

rotary head tape recorders. MR heads can be developed to achieve 300 Mbps and terabit storage in tape recorder formats with low mass, volume, and power. Additionally, high-performance and compact memory modules can be designed that offer higher performance than block access optical and magneto-optical disk drives. Communication has been established with corporations that include Applied Magnetics, IBM, Kodak, Odetics, and Storage Tek, and discussions are under way to support NASA technically in our follow-on FY 1991 baseline demonstration effort.

### Technical Contact

Romney R. Katti, JPL, (818) 354-3054

# Data Storage for Spacecraft

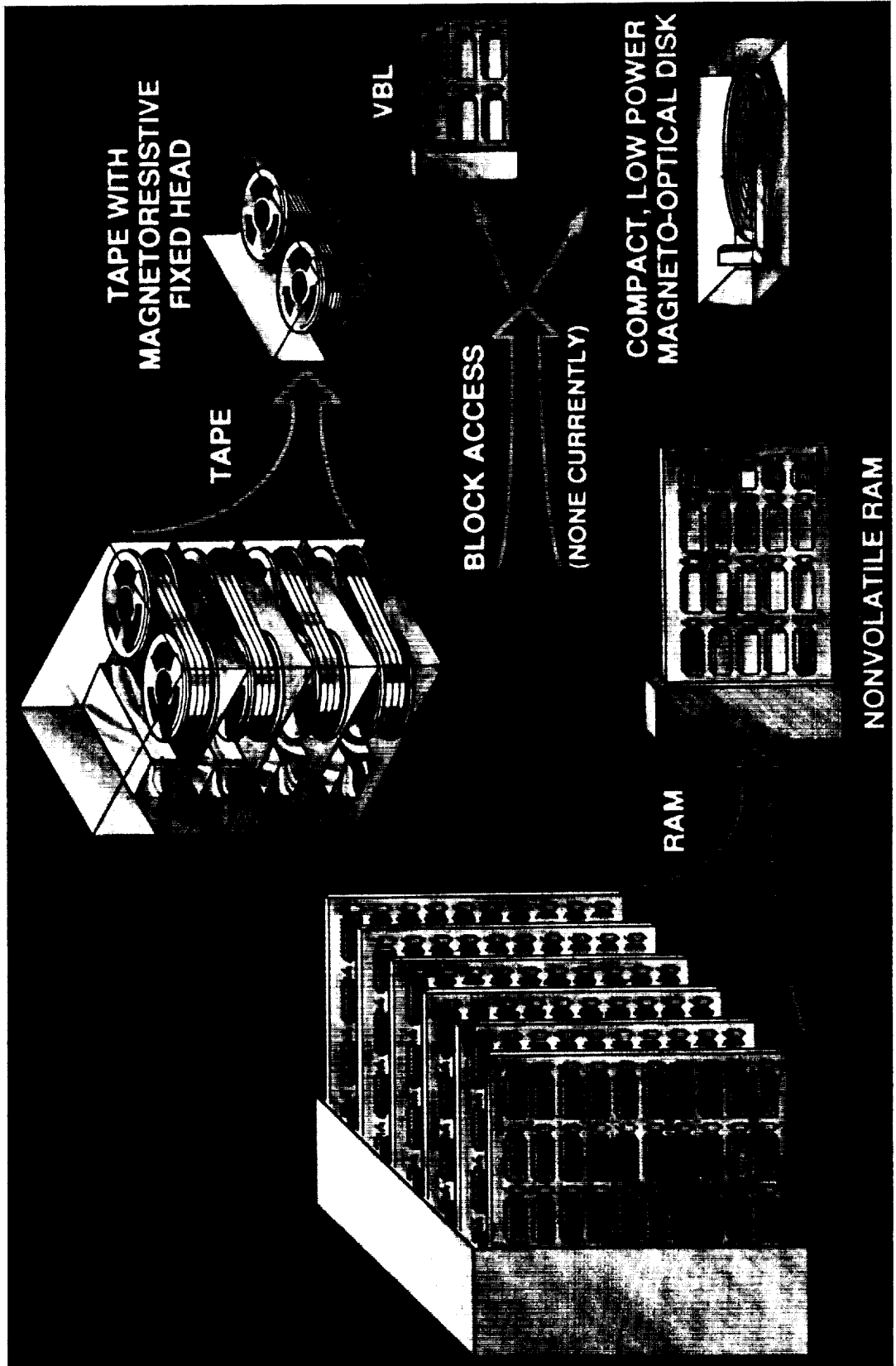

## Imaging Spectrometer Flight Processor — Lossless Data Compressor

The objective of this task is to develop lossless data compression technology for high-rate (up to 500 Mbps) imaging spectrometer focal plane array data for an Earth-orbiting HIRIS mission. Its compression ratio is about 2 to 1. The specific goal is to develop and demonstrate a compressor chip qualified for space by the end of FY 1990.

The unprecedented expanding capabilities of remote sensing imaging systems such as the HIRIS/MODIS has left a big gap in our ability to transmit and store the massive volume of data produced by these systems. In order to utilize the scientific potential of these instruments, without placing unreasonable requirements on telemetry channel bandwidth, a lossless data compression technology must be developed before other high-ratio data compression schemes become available. Such capabilities can enhance the value of advanced NASA space missions from both a science and an operational perspective at minimum cost.

Future Earth-viewing EOS HIRIS systems and planetary flight missions, even in the experimental states, produce large data volumes that tax heavily both the telemetry channel and the storage unit. On-board lossless data compression will reduce by a factor of two the (1) instrument data rates/volumes; (2) instrument data storage requirements; and (3) instrument data downlink requirements. Furthermore, the Very Large Scale Integration (VLSI) implementation will result in reducing the chip count by a factor of five and the system power by a factor of three. Another significant benefit of lossless data compression is more effective ground transmission.

Both the detailed algorithm definition and the performance evaluation of the lossless data compression schemes have been accomplished, and the VLSI design, layout, simulation, and fabrication have been completed. Major milestones for the remainder of FY 1990 consist of finishing testbed fabrication, checkout, and the compressor chip demonstration.

### Technical Contact

Robert E. Anderson, JPL, (818) 354-0213



# CHIP Functional Block Diagram

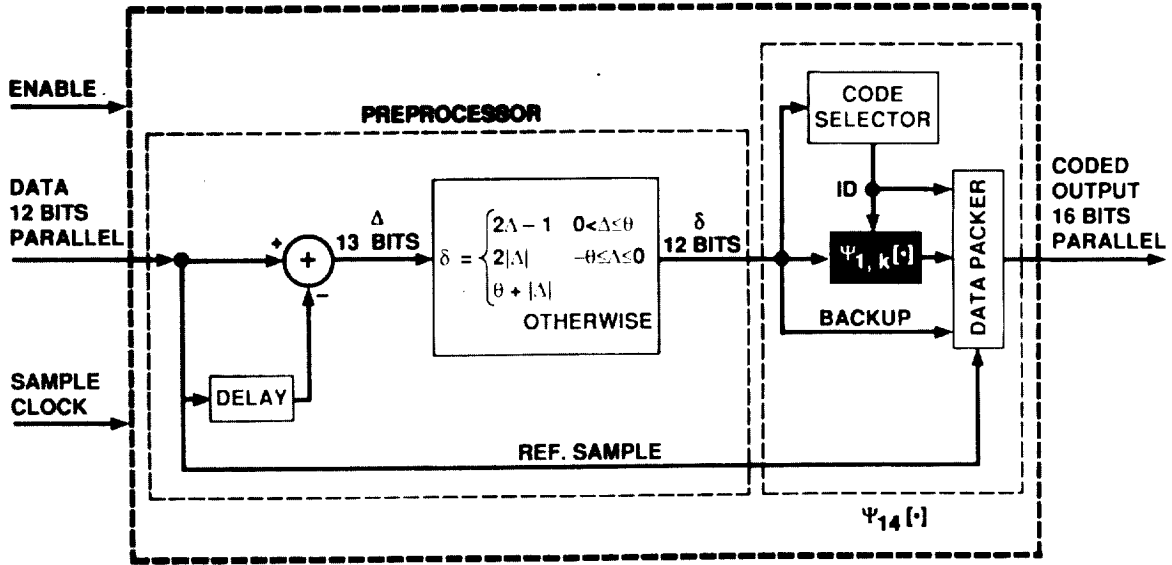

# HIRIS Command and Data Subsystem

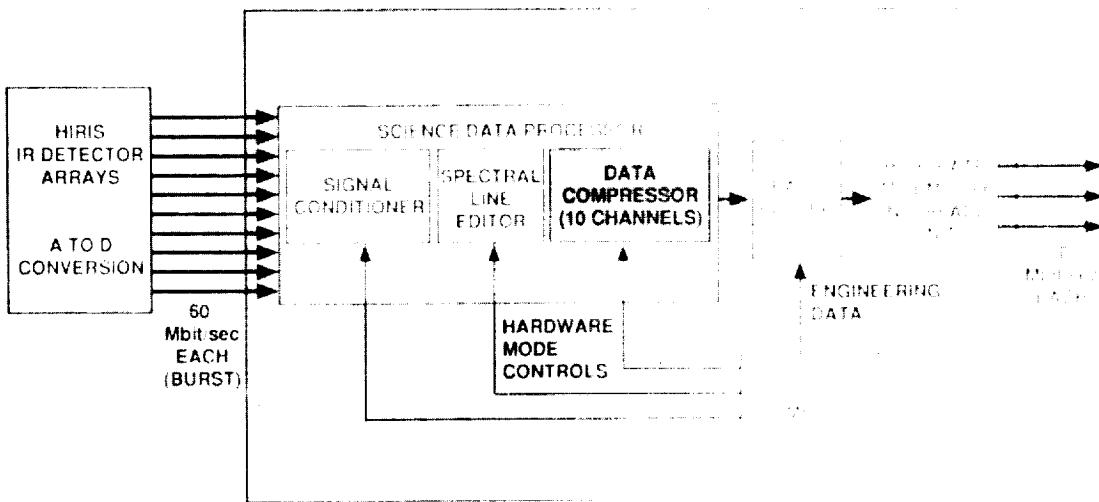

ORIGINAL PAGE IS  
OF POOR QUALITY

## MAX: Flight Multicomputer

The focus of this program is to develop a real-time, general-purpose computing system and environment that addresses the high reliability needs of interplanetary spacecraft and planetary rovers. MAX is a fault-tolerant parallel-computing architecture specifically adapted to tight resource limitations. It has been designed to support a large, heterogeneous collection of tasks in an unpredictable, event-driven environment, and is easily reconfigurable to a wide range of mission requirements.

On-board computational processing technology has unique requirements and constraints. In order to keep costs down and make optimal use of the available hardware without sacrificing reliability, the MAX architecture was developed. MAX consists of any number of conventional computing elements connected via a dual network topology. One network operates as the prime data highway between these elements and I/O, the other as a broadcast medium that synchronizes tightly coordinated real-time events and tasks. Orchestrating these elements is a very high level operating system that allows these tasks to execute in a highly nondeterministic, event- and data-driven environment while maintaining appropriate redundancy for increased reliability.

With the advent of new high-performance spacecraft processors developed by DoD, integrated autonomous spacecraft operation is now possible. The MAX architecture leverages these new device capabilities into a unique system-oriented approach based on hardware resource pooling. This approach maximizes the utility of available hardware and software resources in order to minimize

system mass, power, and volume without compromising reliability.

In 1990, the MAX program continued implementation of fault-tolerant features and of software development tools. A MAX system with three computing modules has been delivered to ARC for independent evaluation. Redundant execution of critical application code with voting of results has been implemented and tested. Very Large Scale Integrated Circuit (VLSI) implementation of the MAX interprocessor communication controllers has begun. A demonstration application that controls an autonomous planetary rover is being developed.

JPL and LaRC have developed a joint plan and specification for the COSMOS computer system, which will combine and build on their experience with dataflow control of multiprocessor systems. This system will use Very High Speed Integrated Circuit (VHSIC) components developed under DoD sponsorship and is projected to handle the foreseeable general-purpose computing needs of NASA missions as well as those of JPL.

FY 1991 plans include completion of the VLSI communications chips and the MAX software tool set. Plans also include starting the implementation of COSMOS on MAX hardware.

Technical Contact  
Blair Lewis, JPL, (818) 354-0912

# MAX Architecture

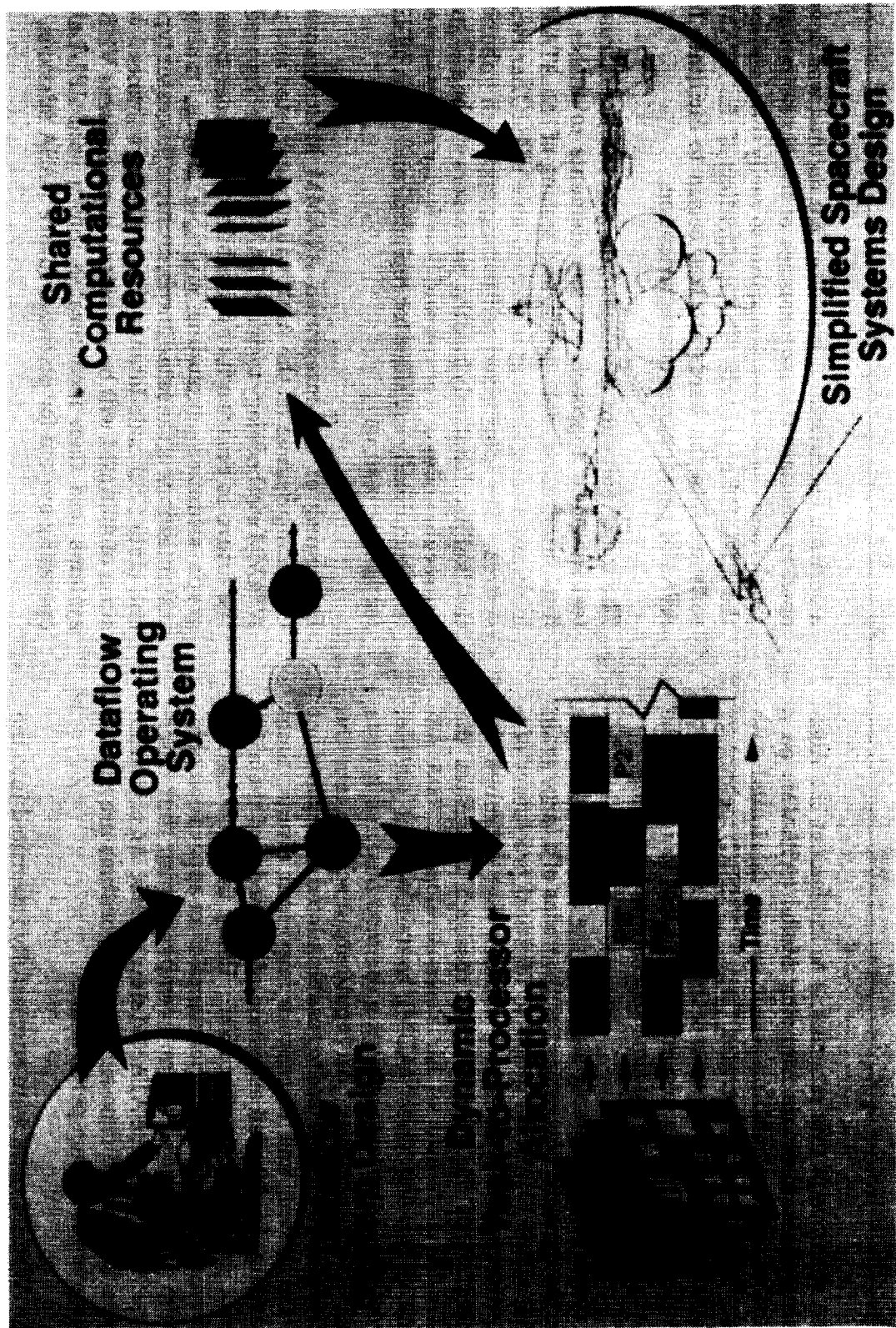

## Evaluation of ATAMM Performance on VHSIC Multiprocessor

The objective of this program is to implement the Algorithm to Architecture Mapping Model (ATAMM) on a general-purpose multiprocessor system fabricated with Very High Speed Integrated Circuit (VHSIC) technology to evaluate the performance of the initial ATAMM concept and to identify enhancements to ATAMM to advance the state-of-the-art for real-time spaceborne processing.

A concurrent processing strategy, the ATAMM provides for the dynamic assignment of the nodes of a large grain application algorithm graph to identical processors of a multiprocessor system in a manner that optimizes the execution of the graph. This research integrates the ATAMM rules into an Air Force-developed 1750A Advanced Develop Model (ADM), containing four parallel processors interconnected on a common bus, and it tests the ATAMM strategy. An input/output scheme uses the system's 1553B interface to pass simulated data in and out of the system and to capture important events, time-marking the detailed execution of the nodes of the algorithm graph during execution. Using the time-marked information, detailed performance of an application algorithm is then analyzed and compared with that determined from separate ATAMM simulations. An algorithm coded in Ada and time-simulated algorithms are used to characterize system performance.

The ATAMM rules were successfully integrated into the Kernel Operating System (KOS), which provides the basic communication functions for the ADM, and the analyzer playback software was completed. The implementation included the intermixing of processor self-testing with

algorithm execution. A test interface method was developed to evaluate the performance of the time-simulated graphs and the Ada test algorithm to verify the viability of the ATAMM approach. The integration of the ATAMM software into the hardware was begun to facilitate full ATAMM performance characterization.

The major software developments and the nonintrusive test interface approach are key elements to enable the final integration, debugging, and testing of the ATAMM multiprocessing strategy in an available VHSIC hardware system. The intermixed self-testing approach enhances the likelihood that only healthy processors will be assigned to execute nodes of a graph and that faulty processors can be automatically excluded (or replaced) and taken off-line for further testing.

Debugging of the integrated ATAMM Multicomputer Operating System on the ADM will be completed and the ATAMM methodology tested. ATAMM will be enhanced in the future to broaden its applicability to a wider class of graph situations including multiple graphs, multiple instantiations of the same graph, multiple processor types, and statistical node-latency times. These enhanced versions of ATAMM will be evaluated in spaceborne VHSIC systems and then incorporated into a joint JPL/LaRC operating system for potential future NASA missions.

Technical Contact

Paul J. Hayes, LaRC, (804) 864-1491

**VHSIC Multiprocessor Flight Brassboard**

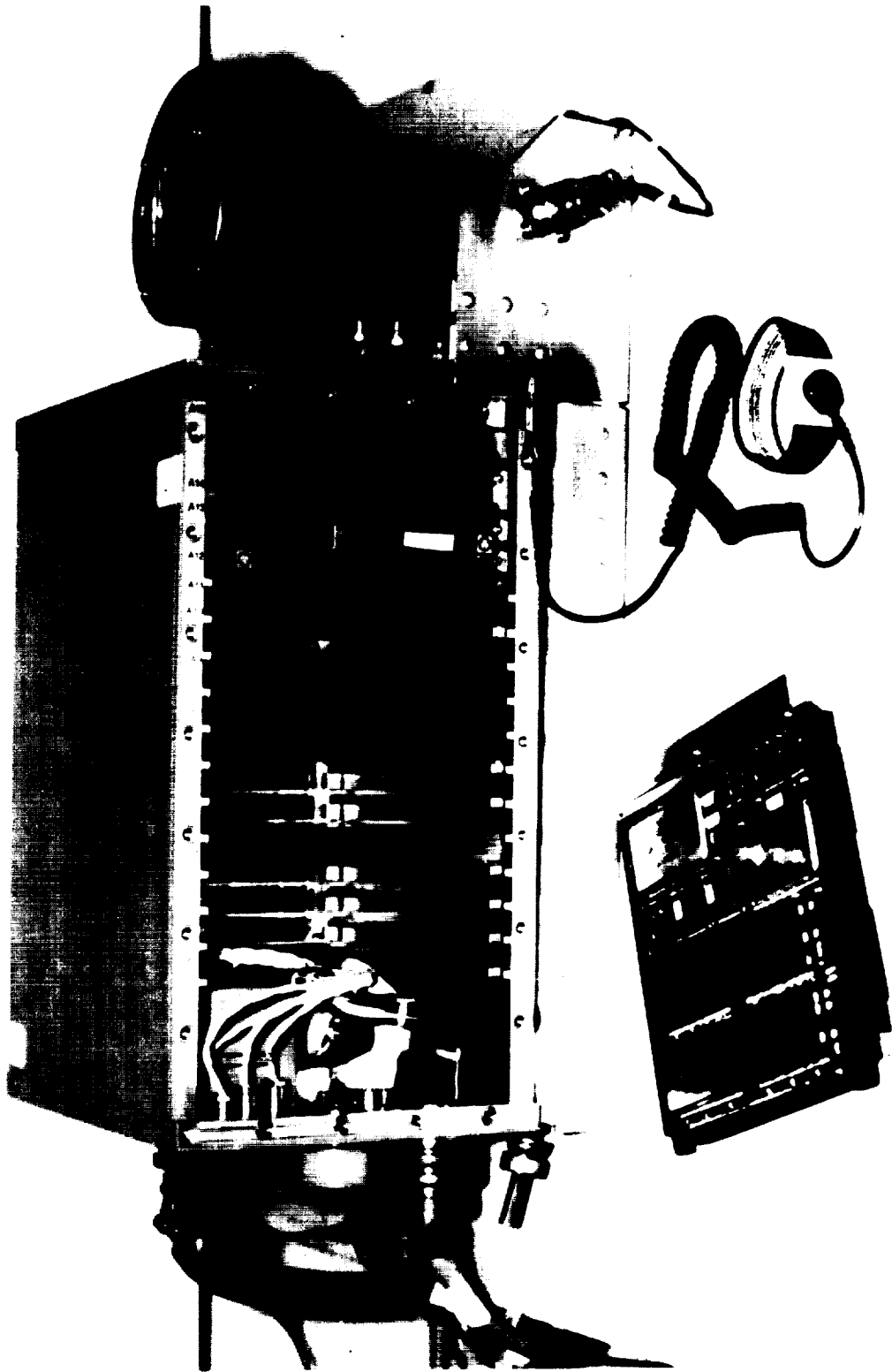

ORIGINAL PAGE IS  
OF POOR QUALITY

ORIGINAL PAGE  
BLACK AND WHITE PHOTOGRAPH

## SODR Controller Development

The objective of this companion program to the Spaceflight Optical Disk Recorder (SODR) development program is to develop a versatile, modular controller that, when combined with SODR disk drive modules, will provide high-performance mass storage systems that meet NASA high-rate, high-capacity spaceflight needs of the 1990s and beyond. The goal is to develop a system with a capacity of greater than 1 terabit (120 gigabyte), up to a 1.8 gigabit-per-second input and output rate, and configurable, expandable architecture to satisfy various applications.

The controller is the enabling element of a versatile recorder. The thrust of this program is to develop a system architecture and controller that allows development of a generic drive unit and provides application-specific user interfaces and expansion in rate and capacity. The focus of the program is application aboard polar-orbiting platforms in support of the Earth Observing System (EOS).

A phased development is planned from breadboard through engineering development and flight qualification. The current emphasis is breadboard design and demonstration of a 2-port operation at 150 megabits-per-second simultaneous read and write or 300 megabits-per-second read or write. This includes verification of system concepts, establishment of operational guidelines, and definition of user interfaces and commands. Breadboard development will culminate in integration with a breadboard drive unit and testbed system demonstration.

During the past year, breadboard controller development has continued. The preliminary design was completed and

culminated in a successful design review, which was attended by government cosponsors and representatives from GSFC. A prototype multiprocessor operating system kernel has been developed and tested. Plans have been formulated and the interface defined for demonstration in a GSFC testbed. EOS application requirements have been established, and a strawman interface and operation scenarios have been defined. Since it is not feasible to breadboard a complete system, a system modeling activity has been included. The model design is complete, and coding has begun.

### Technical Contact

Thomas A. Shull, LaRC, (804) 864-1837

# SODR Controller Development

- BREADBOARD CONTROLLER PRELIMINARY DESIGN COMPLETE
- MULTI-PROCESSOR OPERATING SYSTEM KERNEL PROTOTYPED
- STRAWMAN CONTROLLER-TO-DRIVE AND GSFC TESTBED INTERFACE DEFINED
- EOS APPLICATION REQUIREMENTS AND DATA SCENARIOS ESTABLISHED
- SYSTEM MODEL DESIGN COMPLETE

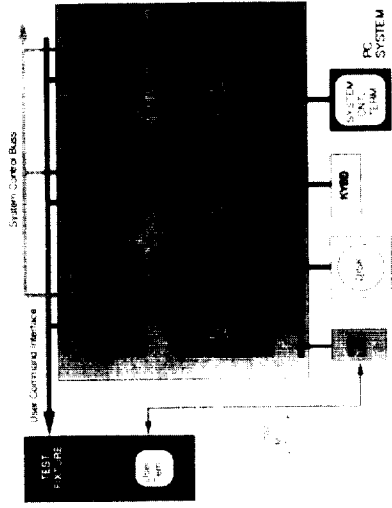

SYSTEM CONTROLLER CONCEPT  
DEMO OF MULTI-PROCESSOR OPERATION

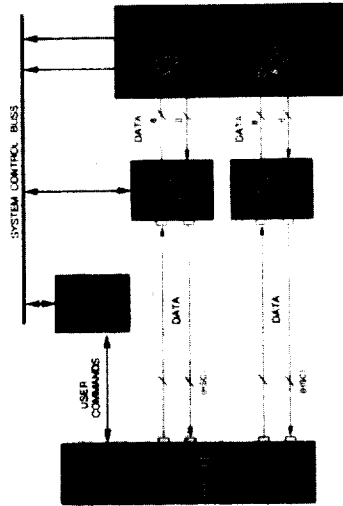

TOP LEVEL BREADBOARD TEST BED  
TWO PORT OPERATION WITH DRIVE SIMULATOR



SODR TO EOS INTERFACE  
MASS DATA STORAGE RESOURCE

## Spaceflight Optical Disk Recorder (SODR)

High-rate, high-capacity data storage has been identified as an enabling capability for future NASA missions including Earth observation, geostationary missions, and planetary exploration in the 1990s and beyond. The SODR program has been established to develop components and subsystems based on rewritable optical disk technology, which forms the basis for high-performance, mass storage systems. There are three technology development areas: 14-inch magneto-optic (MO) media; multielement diode laser arrays; and a multitrack electro-optic head assembly. Feasibility was demonstrated in 1988 and the FY 1990 goal to demonstrate a full eight-track recording has been achieved. Written data are shown in the polarized microscope photo of the "mark" on the media. This represents a 133-megabit per-second data transfer rate and 5-gigabyte (4 X 10<sup>10</sup> bit) capacity on one disk surface exceeding the rate and capacity of any other known disk data storage device.

Also during the past year, a new laser structure was developed that enables more efficient (generating less heat), thus longer-lived devices. Samples have been delivered and are under test at LaRC. A nine-element laser has exceeded 1,000 hours of burn-in (at David Sarnoff Research Center). Glass substrate media have been produced and undergone environmental testing, and media performance optimization for harsh environments is proceeding. This technology is directly transferable to a companion Air Force program. A NASA-sponsored NIST/NASA/DoD/industry working group has been formed to establish rugged 14-inch MO media test standards.

An associated modular controller is being developed at Langley to produce a configurable, expandable system supporting the use of multiple drive modules to obtain data rates in excess of 1 gigabit-per-second (a rate that exceeds any other known or planned optical recording device or flight tape recorder) and capacities up to 1.2 terabits (160 gigabytes).

The current work represents significant technology risk reduction toward development of a completely flight-qualified optical disk drive and controller. NASA and Navy funding are being used to initiate procurement of a brassboard drive unit for flight demonstration in FY 1994.

### Technical Contact

Thomas A. Shull, LaRC, (804) 864-1837



# SODR Program Accomplishments

**MEDIA DEVELOPMENT  
GLASS DISK DELIVERED / TESTED**

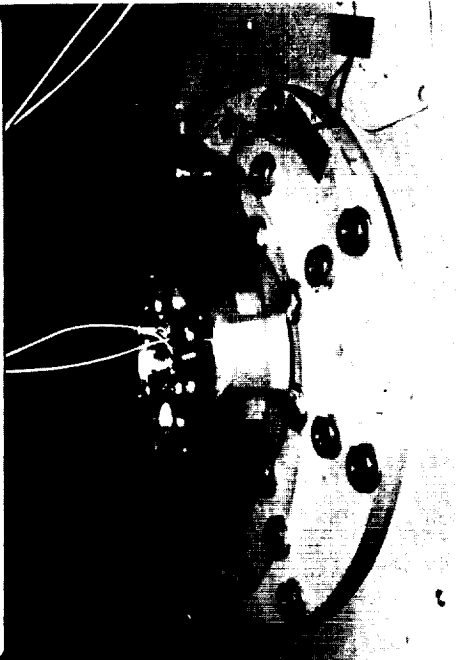

**LASER DEVELOPMENT  
ENHANCED ARRAY DELIVERED / TESTED**

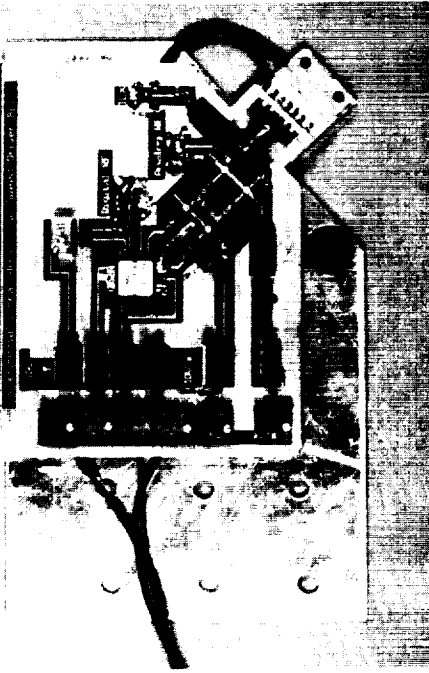

**DRIVE DEVELOPMENT  
ENHANCED BREADBOARD COMPLETE**

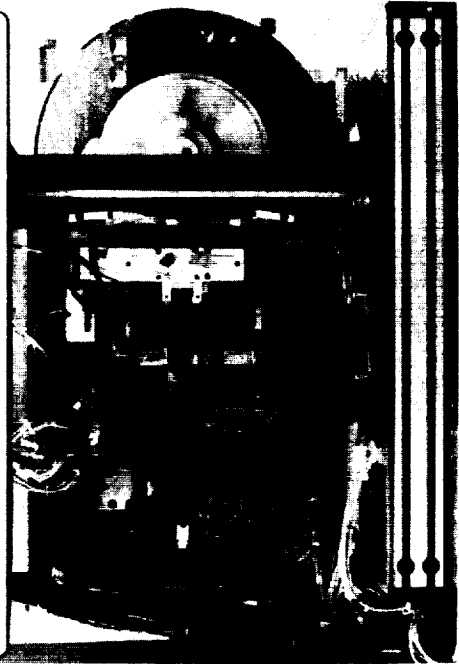

**DEMONSTRATION  
EIGHT TRACK RECORDING @ 133 MBPS**

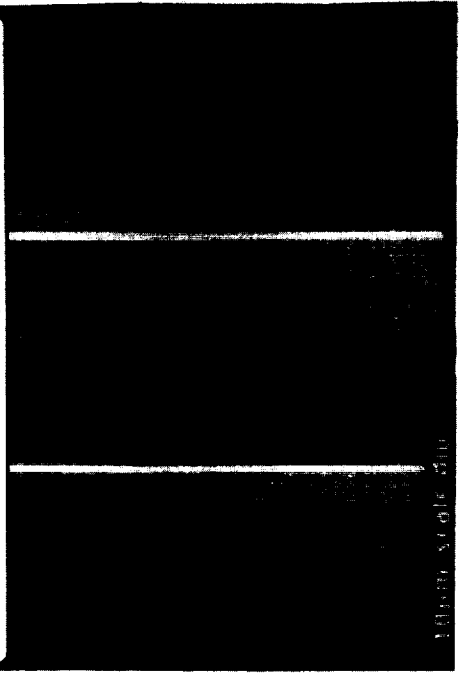



## **Human Factors – Aeronautics**

The objectives of the Aeronautics Human Factors Research and Technology Program are to provide the technology base and capability to design effective crew-cockpit systems and to advance solutions to human factors problems affecting air transport and rotorcraft safety and effectiveness.

In the past 5 years, major steps in cockpit automation have occurred with the introduction of more flexible electronic displays and a variety of automated flight system management devices. They enable third-generation jet aircraft (i.e., B757/767, MD-80/90, and B747-400) to have fully automatic routine flight from takeoff to rollout, regardless of weather, and with reduced inflight workload. Higher levels of automation have been associated with certain problems as well as benefits. The air traffic management system has not kept pace to permit full use of these capabilities. Changes in ATC instructions on the flight crew's tasks, especially during descent or in terminal areas, result in very high workloads and, under some conditions, may divert the crew from monitoring and managing the aircraft's progress and safety.

Major steps in cockpit automation have occurred with the introduction of more flexible electronic displays and a variety of automated flight system management devices. A major focus of human factors research has been directed toward new human-centered interfaces and displays that provide increased margins of safety while taking into account the potential value of computer-based and automated system technology. The multiyear program of research, beginning in FY 1989, is focused on new display technology for use by cockpit crews, human-centered automation, and better use of information processing and management systems within the cockpit and between flight decks and air traffic control stations.

For the past year, NASA researchers at Ames Research Center and Langley Research Center, together with their cooperating universities and contractors, have developed large display devices and presentation methods for restricted visibility cockpits. Other research in computational vision and three-dimensional auditory methods have allowed an expansion of human capabilities to deal with increasingly complex information systems.

NASA researchers, with their academic counterparts, have identified effective methods to reduce fatigue during long, Pacific-rim flights. As a result of these field studies, the value of preplanned, in-seat rest has been identified and quantified.

In the area of helicopter research, NASA has identified major advantages of low level displays for nap-of-the-earth flight. Certain display characteristics can enable the pilot, under heavy workload conditions, to guide the rotorcraft through obstacles under both day and reduced-visibility conditions.

Progress continues to be made in dealing with the complex problems that exist in in-flight diagnostics and datalink methods and in the effects of boredom on cockpit crews.

Program Manager: James P. Jenkins  
NASA/OAET/RC  
Washington, D.C. 20546  
(202) 453-2750

## Automated Recovery Recommendation System (RECORS) Concept Designed, Implemented, and Evaluated for Aircraft Application

---

Aircraft accident and incident analyses reveal that many disastrous aircraft accidents involve multiple subsystems failures. The primary objective of this research effort was to design and implement a knowledge-based system concept to recommend responses to failures involving multiple subsystems. A second objective was to perform a preliminary evaluation of pilot interaction with the RECORS concept.

The input to the recovery recommendation process is a set of fault hypotheses; its output is a description of fault effects and a set of recommended crew responses. The knowledge for the RECORS concept was acquired by interviewing pilots, reviewing airline training tapes and training and operations manuals, and observing pilots in a flight simulator. The primary knowledge base of RECORS consists of qualitative causal models of aircraft subsystems (electrical, fuel, hydraulic), effectors (engines, control surfaces, gears), forces acting on the aircraft (drag, thrust, gravity, lift), and the current flight profiles (air speed, altitude). As shown in the figure, the knowledge encoded in the models is used for assessing fault effects on flight phases and goals, generating recovery procedures, and explaining the reasoning. A preliminary engineering evaluation of the concept was done by having four airline pilots interact with the workstation implementation of RECORS for fault scenarios based on actual accidents and incidents.

A prototype aiding system concept called RECORS has been designed and implemented. Among the preliminary results of the engineering evaluation was that pilots seem

to use different mental models of the aircraft systems for situation assessment than they do for response. This is important because different mental models imply different information is required to support reasoning with those models. For situation assessment, pilots liked having information about the whole aircraft and its individual components. For response, the pilots preferred information about the controls as a single unit rather than divided into individual components. Pilots liked the integrated display because it showed multiple subsystems, and pilots commented that the RECORS concept also had significant potential utility for training.

RECORS was designed to recommend responses (corrective actions) to flight crews, particularly in failure situations involving multiple subsystems. The RECORS concept provides the potential for improved flight crew situation awareness of fault effects and for complete and appropriate responses to faults.

Technical Contact

Kathy Abbott, LaRC, (804) 864-2018

# Recovery Recommendations for Fault Management

## Faultfinder

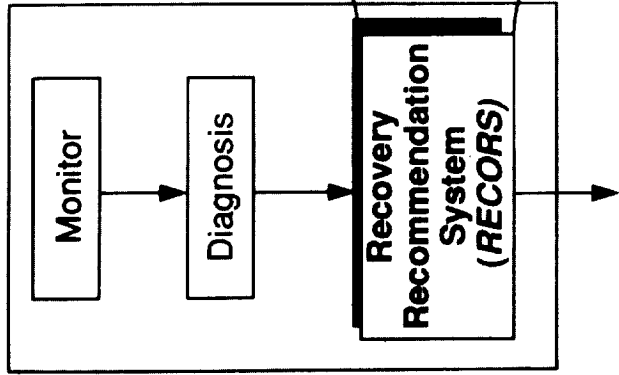

## What RECORS Does:

- Assesses Fault Effects on Flight Phases/Goals

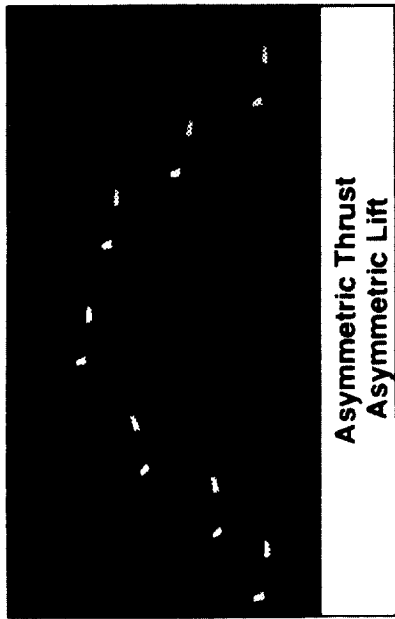

Asymmetric Thrust  
Asymmetric Lift

- Generates Recovery Procedures for
  - Novel Faults
  - Multiple Independent Faults
  - Multiple Subsystems

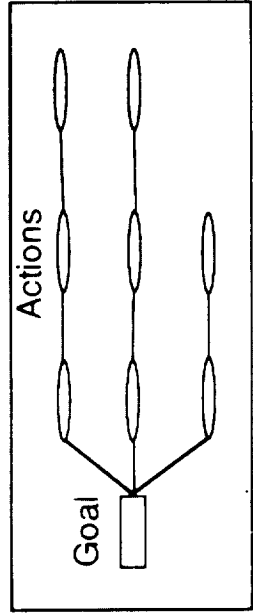

## Brain-Wave Measures of Workload Show Promise for Transitioning From Laboratory to Flight Deck Simulator Environment

Most previous investigations that have addressed the relationship between evoked electrical brain potentials (EPs) and mental workload have focused on responses elicited by a secondary task. To be useful in evaluating the workload of human operators in real-world systems, EP methodology must avoid the use of contrived, and possibly interfering, secondary tasks. The objective of this study was to determine the extent to which EPs elicited by stimuli, as they are processed naturally, would reflect the cognitive workload demands of a complex task.

A laboratory task was designed that provided discrete stimuli to elicit EPs and allowed the manipulation of mental workload, yet was analogous, in many ways, to the types of monitoring activities that are performed in operational environments. In this task, 12 subjects monitored a circular arrangement of six two-digit readouts (see Figure 1). On each trial, the value of one of the readouts changed. Only a subset of the display was salient to subjects, in that they were instructed to monitor either one or three of the six readouts and to report critical readout changes (readout changes that exceeded pre-specified boundaries). EPs were obtained by recording the brain electrical activity following each display change.

Two components of the EP that reflected cognitive workload were discovered. Figure 2 represents EP amplitude components at 250 msec and 450 msec obtained in response to only the critical readout changes in both monitored and non-monitored readouts. The results at 250 msec reveal differences between EPs due to the number of readouts being monitored, regardless of whether the changing (and

eliciting) readout was being monitored or not. The results at 450 msec reveal differences between EPs only when the monitored readout is changing.

These findings appear promising as a way of distinguishing background events (not monitored) from foreground events (monitored) and assessing workload on the basis of EP responses to either event. The results demonstrate the usefulness of EPs as indicators of mental workload in any setting that offers the ability to time-lock recording to a discrete eliciting stimulus.

The assessment technology developed here will be applied to determine the attentional and workload characteristics of a graphics display concept developed for the automated flight deck, the engine monitoring and control system (E-MACS). Laboratory studies will reveal how well the results for numerical displays, described here, will generalize to spatial graphic displays represented by the E-MACS.

Technical Contact

Alan T. Pope, LaRC, (804) 864-6642

Richard L. Horst, ARD Corporation

# Evoked Potential Monitoring Task

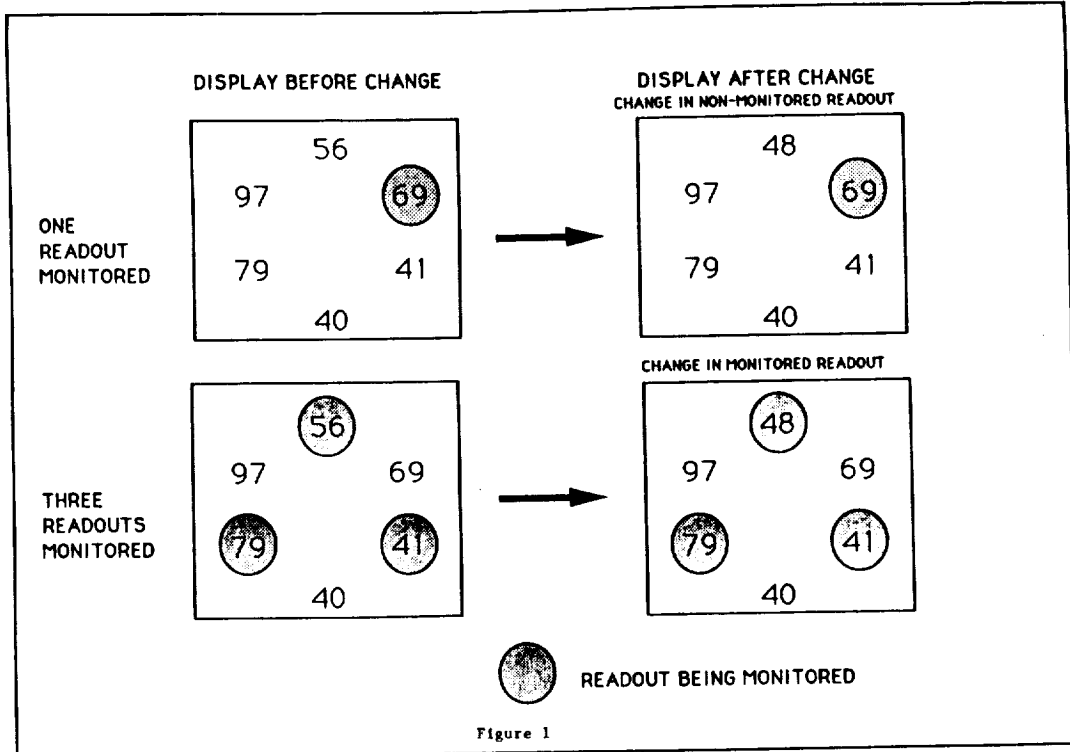

## Workload Effects on Evoked Potential (EP) Peaks

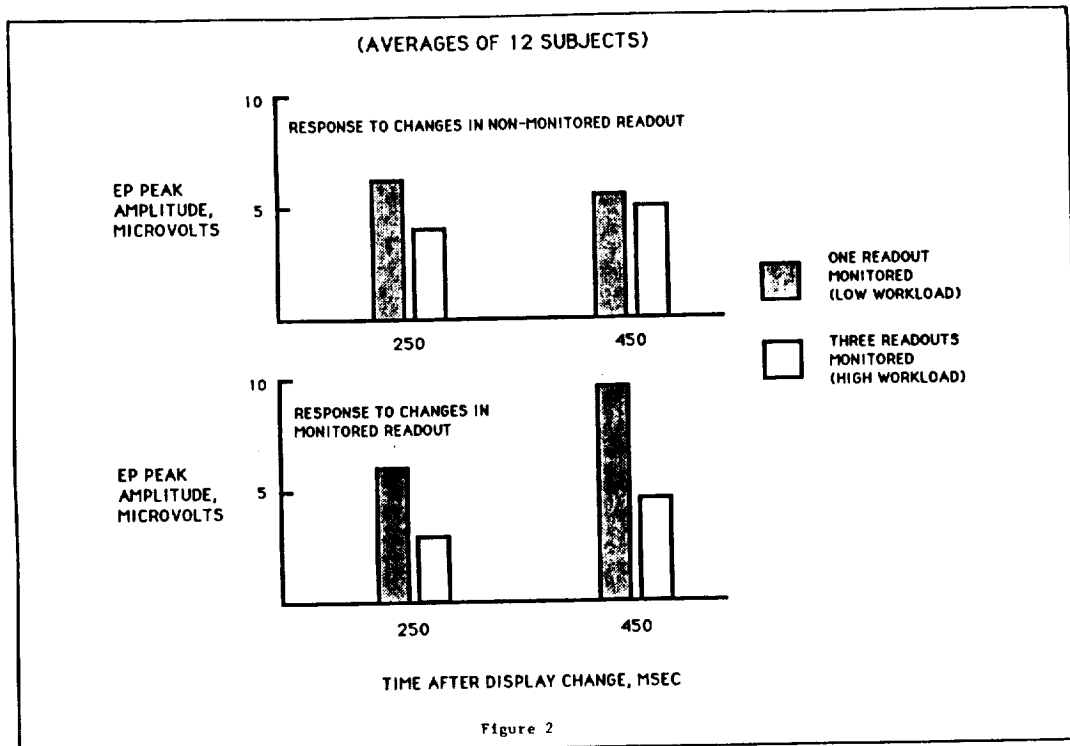

## Flight Testing Validated Knowledge-Based Systems Concept for Primary Flight Display Information Management

An overall research objective has been established to develop concepts that will help flight crews manage extensive amounts of information. As an initial step towards this overall objective, managing information on the primary flight display (PFD) is being explored using a task-tailoring approach. This approach requires complex logic which has led to difficult-to-manage software when traditional programming techniques were used. As a result, a knowledge-based system (KBS) approach was chosen over the traditional programming approach, based on an earlier study that found KBS architectures easier to manage given complex applications. The objective of this particular study was to test the KBSs, collectively called the Task-Tailored Flight Information Manager (TTFIM), in flight to validate their implementation and integration and to confirm the software engineering advantages of the KBS approach in an operational environment.

TTFIM consists of two KBSs, one for information selection and the other for flight phase detection (see figure), and was validated on board the TSRV aircraft in two stages. The first stage of flight tests, in which the flight engineer manually entered the flight phase, was directed at testing the KBS that selected the display information to be presented. The second KBS, for flight phase detection, was tested with a flight-test envelope consisting of multiple repetitions of each flight phase represented in the KBS and with multiple transitions between the flight phases.

The flight tests successfully validated the KBS concept for PFD information management. Correct presentation of information on the PFD during all flight tests validated

the implementation of the information selection KBS and the integration of the two KBSs with each other and with the existing TSRV systems. As expected, the KBS for information selection was not as computationally fast as its equivalent traditional system when selecting some information, but this did not interfere with cockpit operations. The flight-phase detection KBS was successful for all elements within the flight-test envelope except one, with the one logic error that was causing the problem being easily isolated (on-line) given the KBS environment. The flight tests confirmed the software engineering advantages of using KBS architectures for this application and were the first in a civil transport aircraft involving integrated KBSs running in Lisp in real time. The KBSs produced in this effort have also provided a platform that will ease future testing of display philosophies (e.g., task tailoring) by easing the effort required for logic modifications. The flight-phase detection logic developed for this application can be used for other automation tasks needing flight-phase input.

A pilot evaluation of this task-tailored PFD management philosophy is planned. Additionally, plans to change the PFD logic in the TSRV simulator, to make it consistent with the PFD logic on the TSRV aircraft, are being pursued.

Technical Contact

Wendell R. Ricks, LaRC, (804) 864-6733



# PFD Information Management

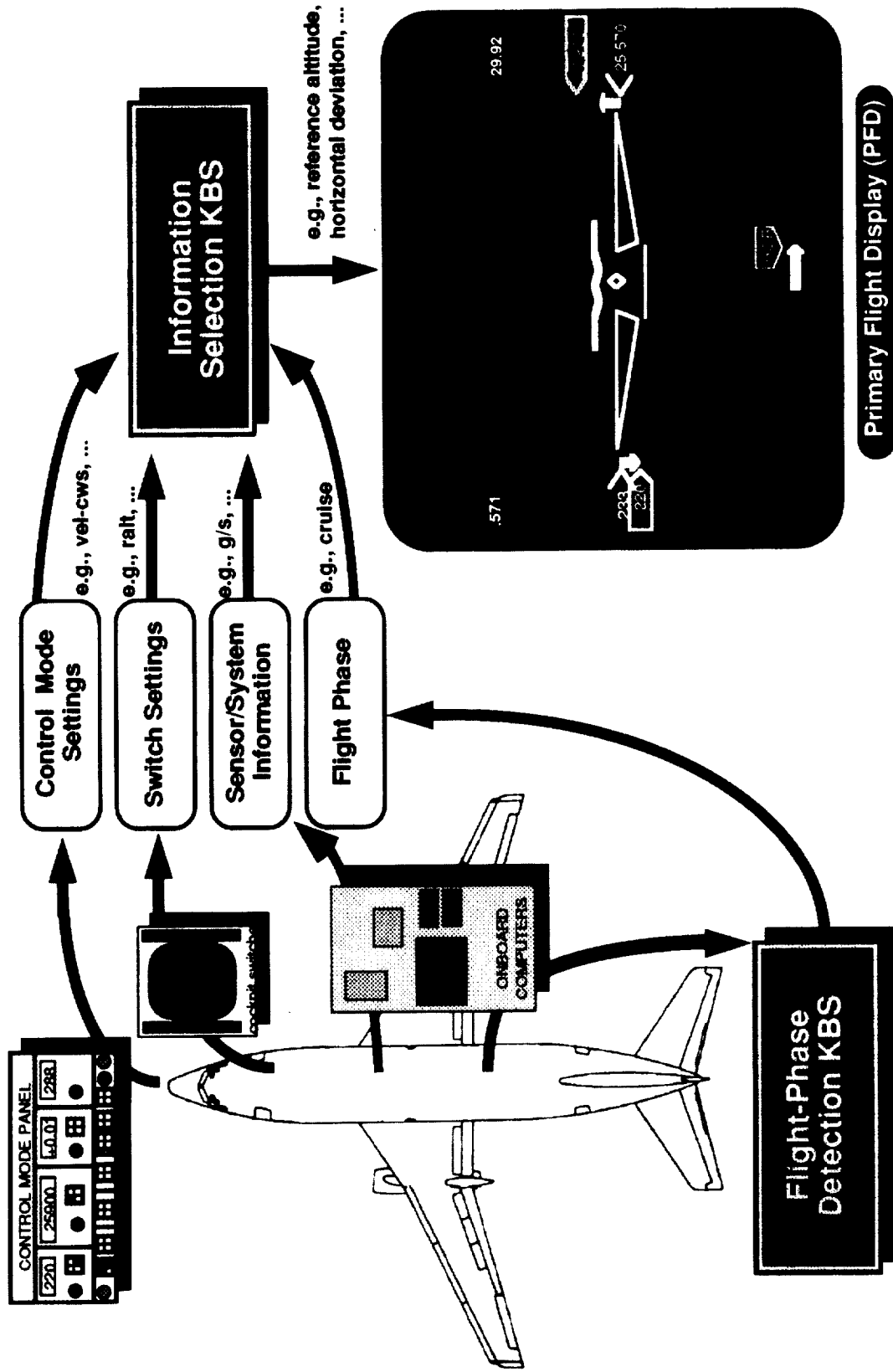

## Head Movement Correction Algorithm Eliminates False Translational Cues from Stereo 3-D Flight Display

"Real-world," 3-D, pictorial displays incorporating true depth cues via stereopsis techniques have proven to be effective means of displaying complex information in a natural way to enhance situation awareness and provide increases in pilot/vehicle performance. However, head movements can seriously distort the depth information embedded in stereo 3-D displays, as the transformations used in mapping the visual scene to the depth-viewing volume depend on location of the viewer. The goal of this effort was to provide parallax corrections for head movements, based on head-movement sensor input data, to the lateral disparity calculations used to generate stereo displays and to verify their accuracy.

Figure 1 illustrates the parallax concept that is employed to produce objects behind a flight display monitor screen via stereo pairs (lateral disparity). If the subject viewing a stereo display moves away from the display screen, and the lateral disparity is not corrected for this movement, the perceived object will appear to retreat farther from the screen. Conversely, if the subject moves toward the screen, the object appears to also move toward the screen. Thus, any head movement effect is exaggerated by the accompanying object movement. To further confuse the viewer, objects presented in front of the screen move in directions opposite to those of objects located behind the screen. An algorithm was developed and implemented that corrects the lateral disparity calculations, based on head-movement sensor input data, to eliminate these exaggerated and confusing object movements. A verification experiment was conducted in the Crew Station Systems Research Laboratory. Since fore/aft movement effects are more

exaggerated than other degrees-of-freedom, the results of the experiment are reported here only for that movement.

Figure 2 presents empirical data from three subjects (nine trials per data point) that validate the movement correction algorithm. The percentage of perceived error is plotted against the object depth placement position (both axes are normalized to screen distance) for both a 20% backward and a 20% forward head movement. Curves are presented for the cases of no head movement, head movement without correction, and head movement with correction.

The head movement correction algorithm effectively eliminates the distortions of depth information embedded in stereo 3-D displays and stabilizes 3-D images to provide a natural "look around the object" capability. These errors are most disruptive with large-screen displays (e.g., projected displays), which allow some freedom for head movement.

The head movement correction algorithm will be used in further applications of stereo 3-D displays, particularly those involving large screen displays, and for helmet-mounted displays with unrestricted head movement.

### Technical Contact

Russell V. Parrish, LaRC, (804) 864-6649  
Steven P. Williams, LaRC, (804) 864-6649

# Stereo 3-D Displays

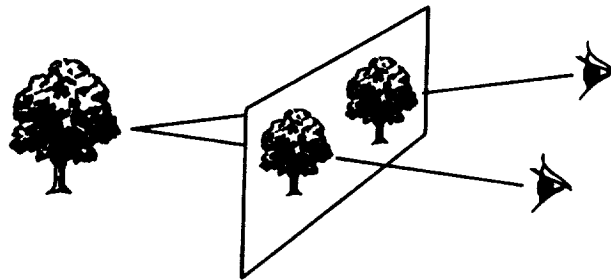

## Parallax Induced Depth Perception

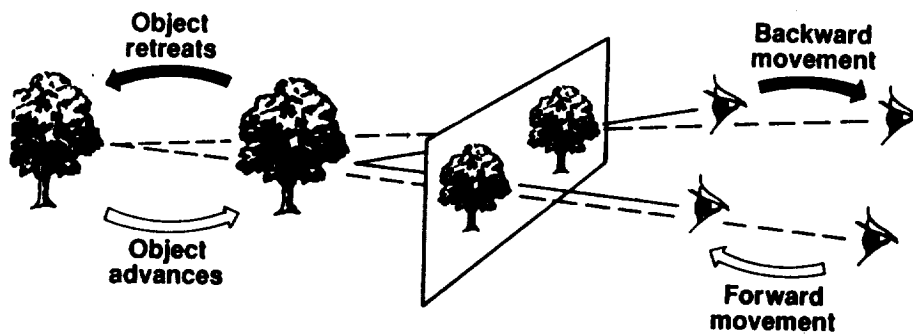

## Head Movement Effects with Constant Lateral Disparity

Figure 1

## Parallax Effect With and Without Correction Normalized to Screen Distance

### NORMALIZED TO SCREEN DISTANCE

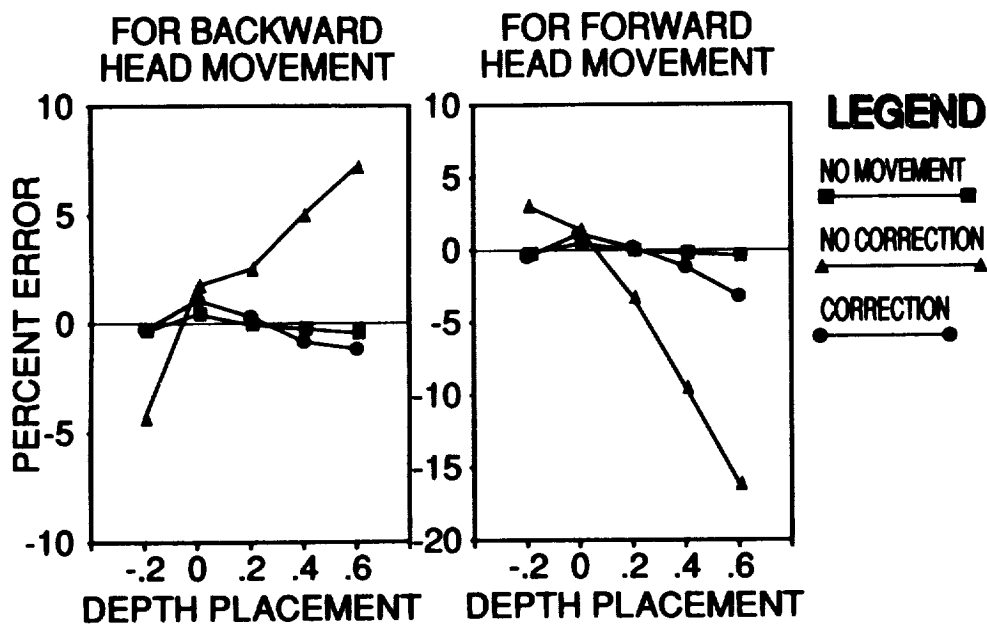

Figure 2

## Heads-Down Stereoscopic Flight Displays

Current electronic technology can provide high-fidelity pictorial displays under flicker-free conditions that incorporate depth in the display elements. The application of stereoscopic (true depth) cuing to advanced heads-down flight display concepts offers potential gains in pilot situation awareness and improved task performance, but little attention has been focused on a fundamental issue involving its use. The goal of this effort was to resolve the question of whether short-term use of heads-down stereoscopic displays in flight applications would degrade the real-world depth perception of pilots using such displays.

Stereoacuity tests are traditionally used to measure the real-world depth perception of a subject. Stereoacuity is the smallest resolvable difference in depth, determined from the measurement of attempted placements to the same depth of two targets originally positioned at different distances from the observer. Eight transport pilots flew repeated simulated landing approaches using both nonstereo and stereo 3-D heads-down pathway-in-the-sky displays. At decision height on each approach, the pilots transitioned to a stereoacuity test using real objects rather than a 2-D target test apparatus.

Statistical analysis of stereoacuity measures, comparing a control condition of no exposure to any electronic flight display with the transition data from nonstereo displays and stereoscopic displays, revealed no significant differences for any of the conditions. The mean values of stereoacuity for each condition, averaged over pilots and replicates, are shown in Figure 1. The data for each individual pilot are shown in Figure 2. Tests for statistical

significance for the individual data did reveal some difference. In only one instance (pilot 2) was depth perception degraded from the control condition, and that case was significant only for the transition from nonstereo displays. In all other cases, there were either no differences or the acuity was improved over the control condition. Clearly, transitioning from a heads-down stereoscopic display has no more effect on real-world depth perception than transitioning from a nonstereo display.

A fundamental issue challenging the application of stereoscopic displays in heads-down flight applications has been resolved with the determination that real-world depth perception is unaffected by the short-term use of stereo 3-D displays.

Another fundamental issue challenging the application of stereoscopic displays in flight situations—the effect of long-term stereoscopic display exposure on pilots' stereoacuity—will be investigated.

### Technical Contact

Anthony M. Busquets, Steven P. Williams,  
Russell V. Parrish, LaRC, (804) 864-6649

## Stereoacuity Experiment Results

**Control Condition Vs. Transition From Flight Displays  
(Averaged Data From 8 Pilots)**

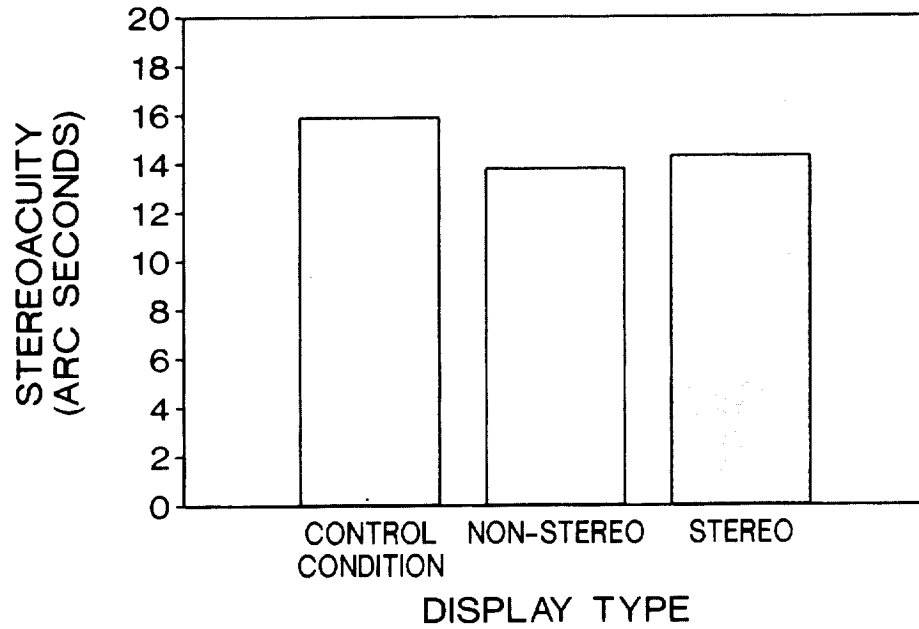

Figure 1

**Control Condition Vs. Transition From Flight Displays  
(Individual Pilot Results)**

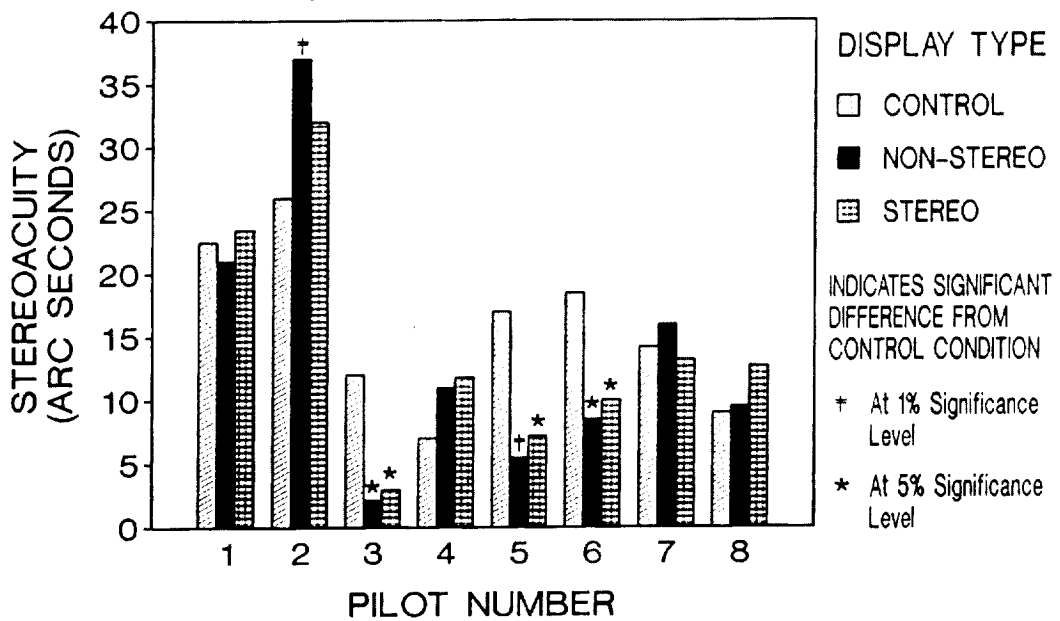

Figure 2

## Improved Prototype Decision-Aiding Concept and Pilot-Vehicle Interface (PVI) for In-Flight Diversions

A current problem in flight operations is the high pilot workload required while responding to flight plan diversions, especially during critical flight phases. The overall objective of the Phase I research effort was to develop concepts based on artificial intelligence (AI) techniques to reduce pilot workload and to provide guidelines for the integration of AI concepts into current and future flight management systems. This work was performed under NASA contract by Lockheed Aeronautical Systems Company. The objective of the Phase II task was to develop concepts for the pilot-vehicle interface and to improve the prototype decision-aiding software functions developed in Phase II.

Using the results from Phases I and II, the information flow between DIVERTER (the expert system developed for this effort), the pilot, the on-board systems, and external sources such as ATC was assessed. The pilot-vehicle interface requirements were then determined, and a rigorous specification of an interface concept and the design process that produced this concept was completed. The specification of the design process included the alternatives that were considered and the reasoning behind each design decision made. The function of the DIVERTER prototype software was improved by (1) integrating the selection process for airfields and routes; (2) dynamically predicting movement of weather cells; and (3) modularizing the code so that the demonstration drivers for the aircraft simulation and map display can be replaced easily by links to a research simulator such as NASA's Advanced Concepts Simulator (ACS).

A presentation of the interface design and a demonstration of the improved DIVERTER prototype software have both been accomplished. The pilot-vehicle interface concept and its accompanying design process specification will provide a solid foundation as well as flexibility during definition of simulator cockpit displays. The DIVERTER demonstration software package incorporates all specified enhancements and has many improved features for highlighting the capabilities of the decision-aiding concept.

The current progress in this research effort further demonstrated the feasibility of decision aiding for flight plan diversions. The expected benefit of integrating these concepts into flight management systems is enhanced flight safety through a reduction in peak crew workload.

During the next phase of this research effort, which will be conducted on-site at LaRC, the DIVERTER decision-aiding concept will be tested in the Advanced Concepts Simulator. In future phases, flight tests aboard the ATOPS TSRV B-737 aircraft are also planned.

Technical Contact  
Michael T. Palmer, LaRC, (804) 864-2044

## DIVERTER – Decision Aiding for Diversions

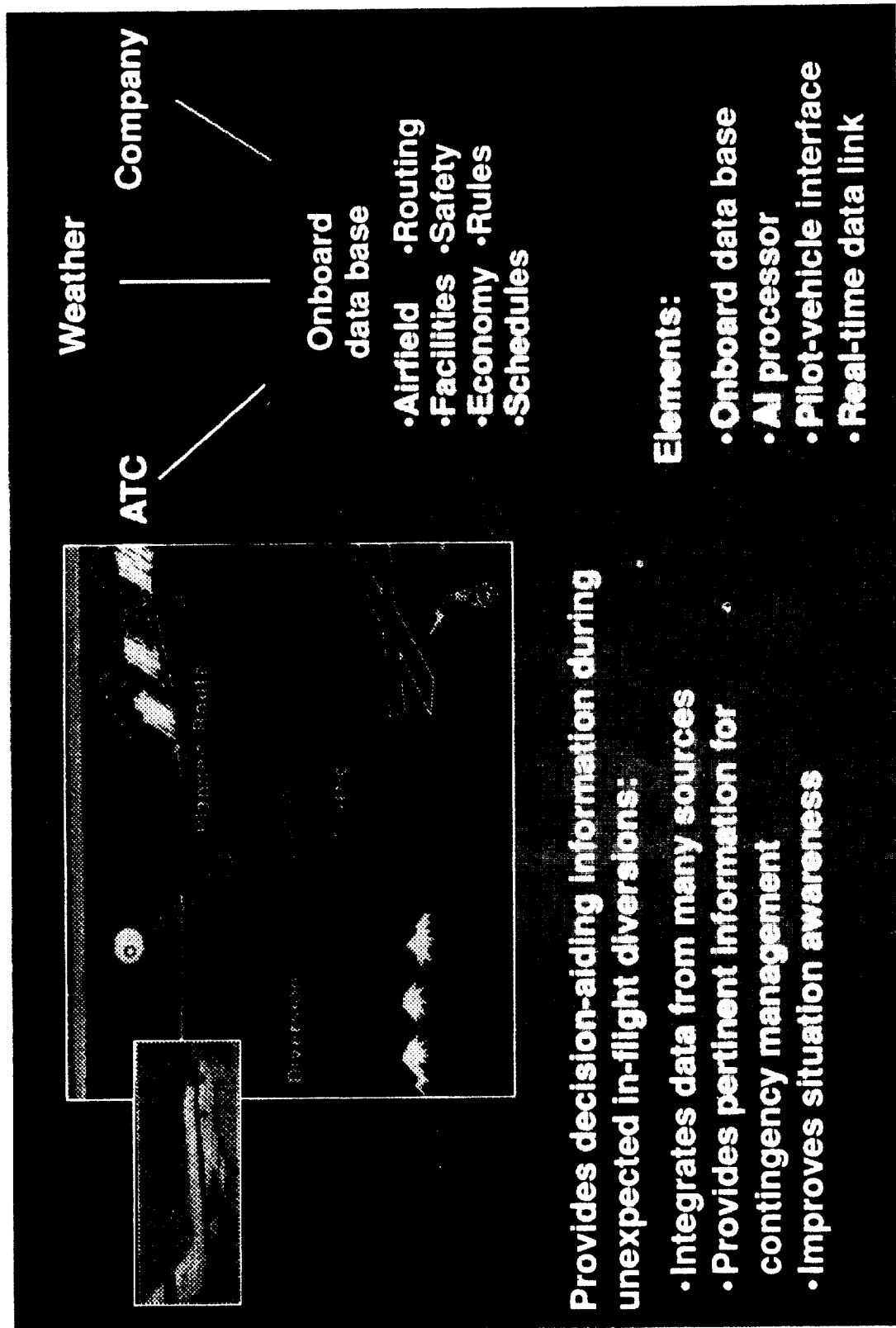

## Information Fusion to Improve the Detection of Wind Shear Threats

The objective of this study was to explore the fusion of different types of wind shear detection information with corroborating weather information to produce a more reliable estimate of the wind shear hazard than each of the wind shear detection methods could have produced independently. Such an increase in reliability could increase the probability of wind shear detection and reduce the number of nuisance warnings.

The FAA has developed a training aid to help pilots recognize and avoid wind shear. This training aid instructs the pilot to collect data from different weather sources and combine that information with his/her own visual and tactile information. The training aid provides an excellent example of information fusion. The first step toward the objective was to automate the information integration outlined in the training aid using an expert systems approach. Expert systems were chosen because the fusion structure developed within the training aid (i.e., rules) mapped well to this approach.

The grant produced a research prototype wind shear recognition expert system which attempts to detect and classify wind shears through various sources of input data (e.g., ATIS reports, LLWAS, air data, pilot visual sightings, and PIREPS). The prototype produces rudimentary assessment of the wind shear and rudimentary guidance (e.g., "high probability of wind shear!" and "abort takeoff"). The prototype has 140 rules and is written in Common-Lisp on a Symbolics Lisp machine. The study also identified issues that will need to be explored such as the usefulness and availability of certain inputs, the effects of

false alarms on flight crew confidence, and user interface.

The prototype produced in this effort provides a basis for exploring the fusion of wind shear-related information to provide a more complete and accurate assessment of hazardous wind shear. The lessons learned from this exploration can aid the development of systems that help reduce the number of inadvertent encounters with wind shear while minimizing the number of false/nuisance alarms. Such systems could lead to improved safety with a minimal impact on operational efficiency.

Future plans for this effort include the fusion of airborne forward-look sensor data into the detection process, an increased use of evidential reasoning with the prototype, an improved simulation of airport and aircraft for testing the prototype, and an assessment of aircraft safety versus pilot acceptance in the presence of false alarms and missed alarms.

### Technical Contact

David A. Hinton, LaRC, (804) 864-2040

Paul C. Schutte, LaRC, (804) 864-2019

Robert F. Sengel, Princeton University, (609) 452-5103



# Use of Information Fusion to Improve the Detection of Wind Shear Threats

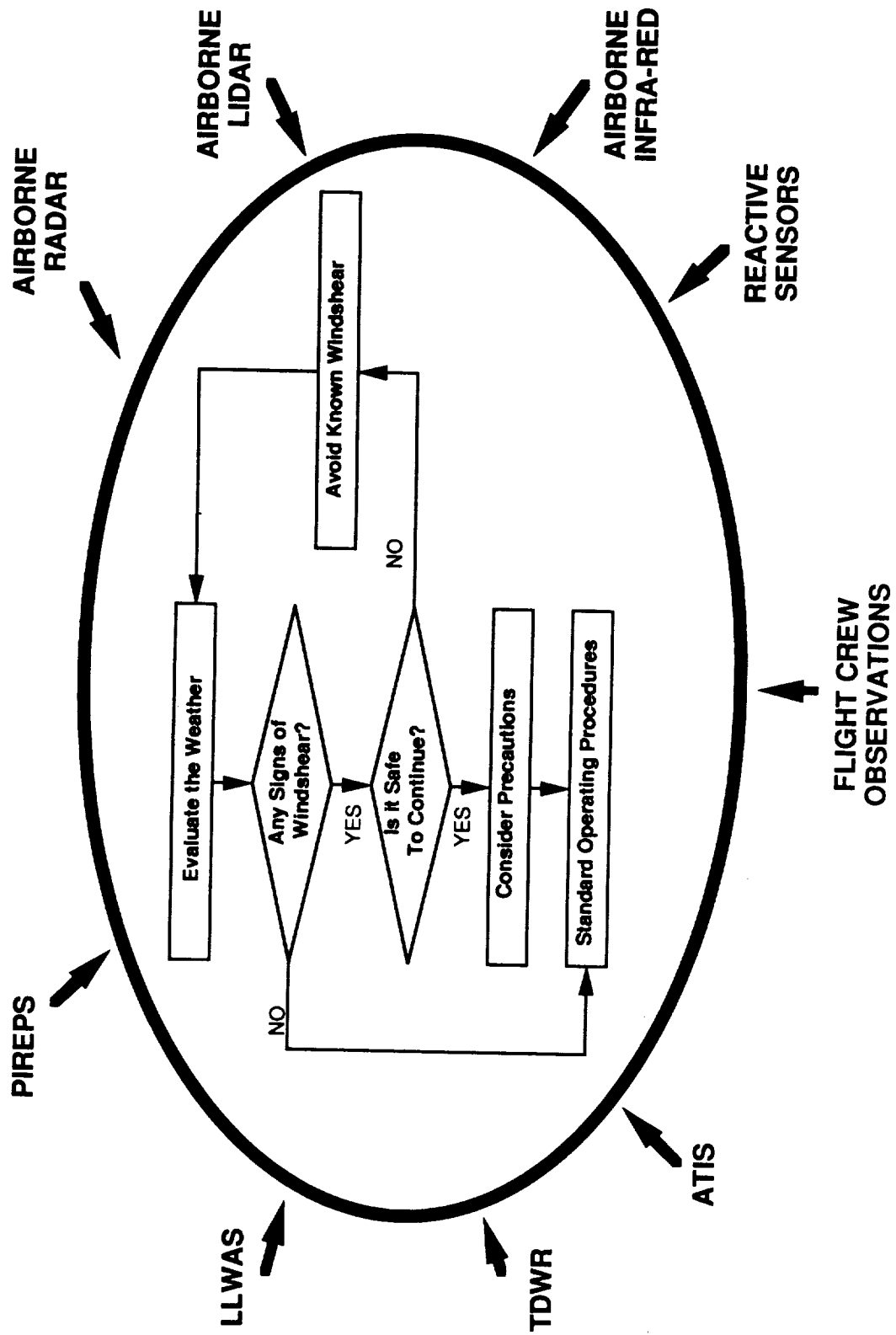

## Performance Effects of Alternate Pathways and Stereo 3-D Presentation Determined in a Pictorial Display for Transport Landing Approach

The objective of this research was to determine the performance of the "pathway-in-the-sky" format in a transport complex-path approach and the effectiveness of two competing pathway formats, and further, to investigate the effect of their presentation in stereo vs. nonstereo modes.

A real-time, piloted simulation experiment assessing performance in a transport landing-approach-in-turbulence task was conducted. The experiment compared an NADC-like tile pathway and a goalpost pathway presented in stereo and nonstereo modes. Figure 1 illustrates the alternate pathway formats as well as the visual task chosen for the experiment (i.e., maintaining range separation with a lead aircraft while flying the desired curved, decelerating, descending, landing approach pattern). Separation was regulated with the location of the desired range marker element.

Figure 2 presents the mean standard deviation of path error results from seven Air Force transport pilots who each flew 20 approaches with each display format. The overall operational precision of both formats proved to be exceptional. The variation in vertical path error as indicated by the standard deviation was 10% less for the tile format, the variation in lateral path error was 11% less for the goalpost format, and the difference in variation in range path error was not statistically significant. The inclusion of stereo depth cues improved range-separation performance by 18% over the nonstereo control condition.

"Pathway-in-the-sky" integrated, pictorial display formats appear to offer exceptional path-control precision for future

transport operational environments that require complex-path approaches. While the objective data results for the competing pathways do not appear to be operationally significant, most pilots preferred the tile format for vertical control and the goalpost format for lateral control maneuvering. All pilots preferred the enhanced range and rate-of-course cues provided by the stereo version of the formats.

Innovative concepts will be explored to exploit the strengths of each of the above formats (e.g., incorporating the vertical sides of the goalpost into the tile format - a rough format), and stereopsis cuing enhancements will continue to be investigated.

### Technical Contact

Anthony M. Busquets, LaRC, (804) 864-6649

Russell V. Parrish, LaRC, (804) 864-6649

Steven P. Williams, LaRC, (804) 864-6649

# Pilots' Visual Range-Tracking Task and Alternate Pathway Formats

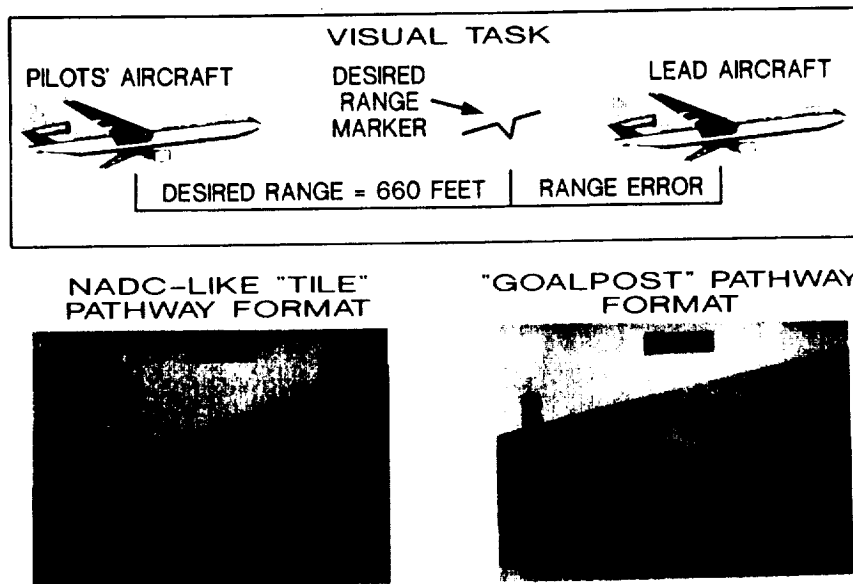

Figure 1

## Effect of Pathway Format on Simulated Landing Approaches

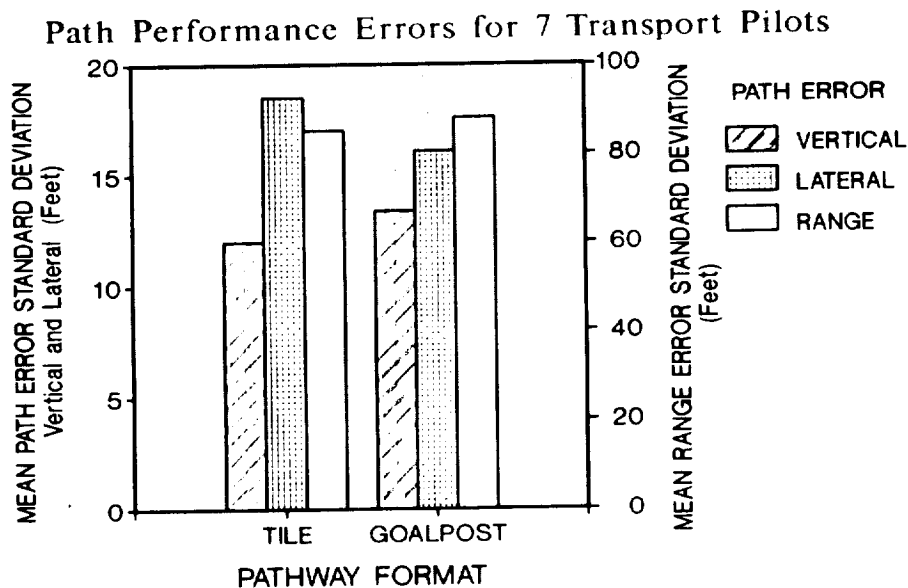

Figure 2



## Human Factors - Space

The major goal of the Space Human Factors Program is to provide the technology that will enable safe and productive human performance throughout and after space flights and planetary/lunar missions of long duration. Two elements of the program are Human Factors and Extravehicular Activity Systems. The Human Factors element has three major subgoals:

Human Performance Models, Data, and Tools allow us to understand human activities in the physical, mental, and perceptual domains and to identify important lessons learned about human activities from prior space and lunar missions. To this end, Johnson Space Center is using a laser-based human body mapping system to measure different anthropometric sizes and shapes for incorporation into a large data base. This data base is employed, along with a spatial computer image graphics system, to analyze human motion under zero-gravity conditions, from the simulated human bodysized figure performing a variety of new activities on board Space Station *Freedom* or the Shuttle orbiter. At Ames Research Center, human performance models for computer-aided engineering, a program initially developed for aeronautical applications, are being modified for space applications.

Crew Support and Enhancement address the development of technology and its applications for the evaluation of the crew's living and working activities in the spacecraft, in the planetary/lunar habitat, and on planetary/lunar surfaces. During the year, a number of projects were completed. At Johnson Space Center, new computer graphics were developed, particularly new graphics methods for portraying procedures that reduce human error. Also, advances in information management methods for application to Shuttle maintenance operations were developed at Ames Research Center. Data from Kennedy Space Center operations are being used as a testbed for managing information processing in Shuttle maintenance operations.

Human-Automation-Robotic Systems determine the means by which humans and automated or semi-autonomous systems can effectively work together. A major project at Ames Research Center is the development of the Virtual Workstation as a user interface device for exploring lunar or planetary surfaces. The effort this year has been to obtain a MARS-like data base and begin to employ it in simulated missions. At Johnson Space Center, effort was directed toward identifying the best location of visual sensors for teleoperations.

The second major area of technology development is Extravehicular Activity (EVA) Systems. In the past year a formal test and evaluation program for the AX-5 and the Zero PreBreathe Mark III EVA suits was completed, and results were evaluated by an internal NASA panel of experts and astronauts from Ames Research Center and Johnson Space Center. Research to develop a voice-actuated control system for commanding a data display on EVA suits was completed. Initial concepts for a wrist-mounted electronic display for EVA suits were developed at Johnson Space Center.

Program Manager: James P. Jenkins  
NASA/OAET/RC  
Washington, DC 20546  
(202) 453-2750

## Advanced Extravehicular Activity (EVA) Suit Technology

---

The ARC has an ongoing program to address EVA suit technology requirements for the Space Station and advanced exploration missions. A product of this effort has been the development of the Ames AX-5 space suit. The overall objectives of this development effort have been to provide a high-mobility suit technology that eliminates the need for prebreathing, provides increased hardware and systems life span, minimizes maintenance, provides increased hazard protection, and accommodates a large population sizing capability.

As part of the overall evaluation process, a series of tests have been established at JSC to assess the performance of advanced suit concepts as compared to the current Space Shuttle EMU. These tests consist of mobility

range comparisons, torque force work capability, general workstation performance assessment, and the EASE/ACCESS structure simulation.

Throughout 1989, additional test of the AX-5's mobility and range of motion were completed in the JSC Weightless Environment Test Facility (WETF) and in the KC-135 Zero-Gravity Aircraft. Suit joint cycle life tests have been completed as part of the Suit Evaluation test matrix. The AX-5 suit joints passed all cycle life tests. The AX-5 is currently undergoing modification to incorporate a waist bearing.

### Technical Contact

Hubert C. Vykukal, ARC, (415) 604-5386

**Demonstration of EVA Suit Technology**

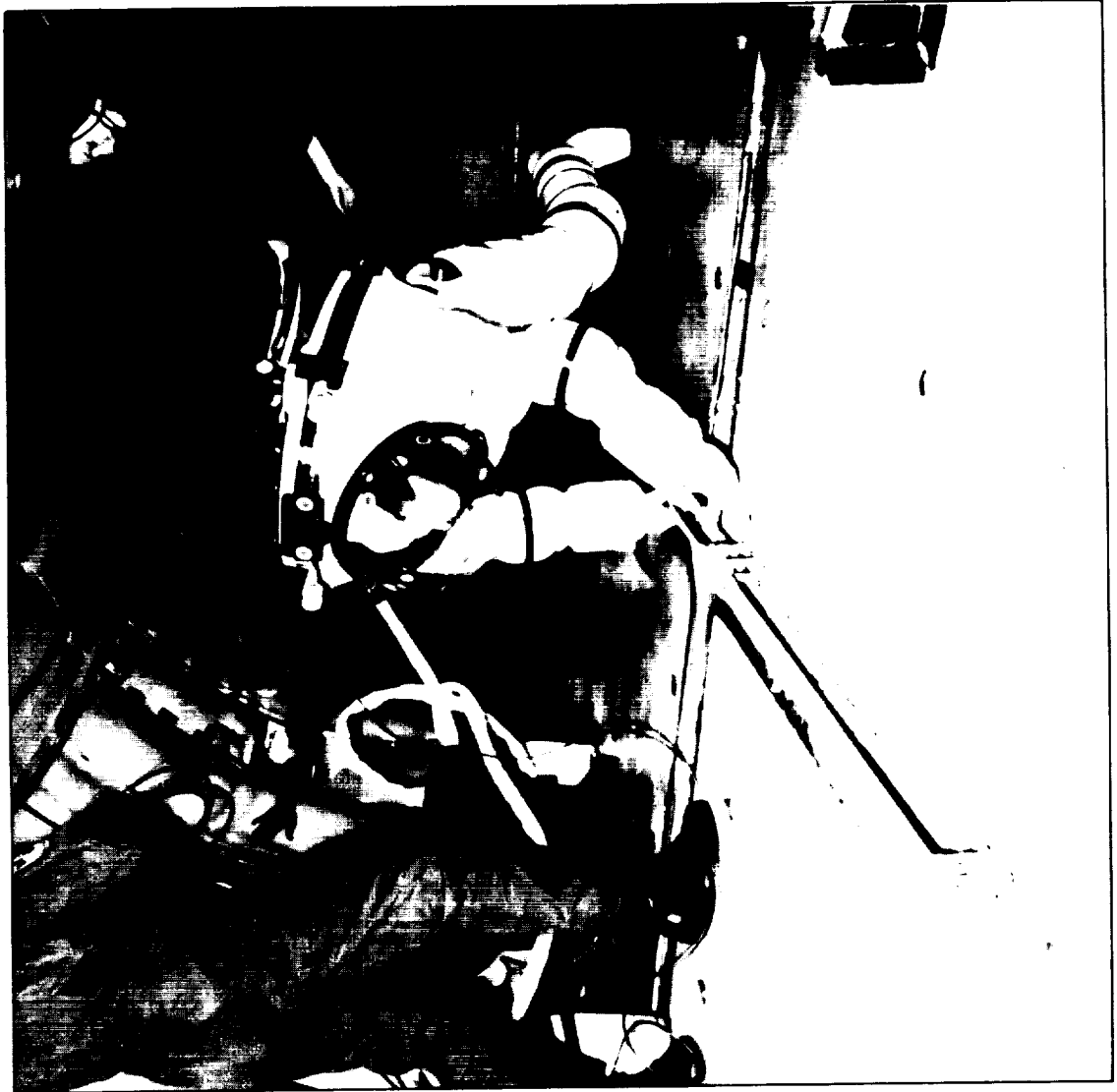

ORIGINAL PAGE IS  
OF POOR QUALITY

ORIGINAL PAGE  
BLACK AND WHITE PHOTOGRAPH

## Computer Graphic Representation of Visual Space

This research effort in human visual representation will develop computer graphic methods for delineating and testing hypotheses about the relationship between two-dimensional visual field maps and the three-dimensional visual space served, under the conditions of (1) changing eye position; (2) occlusion by structures that are part of or mounted on the observer, such as facial structures, goggles, or headgear; (3) occlusion by environmental objects; (4) normal and abnormal defects of the visual field, such as blind spots and areas of temporarily reduced visibility due to local adaptation and photopigment bleaching; and (5) variables that alter the focus of environmental objects on the retinas (accommodation and pupillary responses). Combined with other models being developed under the A<sup>3</sup>I program, the computational methods produced by this grant with Dr. Aries Arditì at the New York Association for the Blind will enable crew station designers using MIDAS to perform visibility assessments of potential cockpit designs while still in the conceptual development phase. Such design tools have a tremendous potential to reduce overall design cost and enhance the quality of the final product.

A three-dimensional computer-aided design tool developed by the A<sup>3</sup>I program staff will be used to rapidly develop prototype geometric models of representative cockpit controls and displays. JACK, a geometrical model (mannequin) that can be resized, of pilot anthropometrics is used to determine pilot head position and pilot point of regard in the field of view. Instantaneous field of view computations based on these factors will determine which volumes in the visual space can be seen and which are

obstructed from view in both eyes and therefore cannot be seen. The volumes will be visualized by rendering the space in different colors with respect to the simple criterion of visibility, or the space can be rendered with the invisible elements removed. This approach provides the first step toward enabling the crew station designer to see the way a control or display will appear to the pilot's eyes under actual ambient lighting conditions, obstructions, and head/eye positions, rather than solely representing the control or display under typically ideal conditions.

Initiated in 1988, a preliminary version of this binocular volumetric field of view model has been integrated with the A<sup>3</sup>I MIDAS workstation in preparation for demonstrations scheduled during the summer of 1990.

### Technical Contact

James O. Larimer, ARC, (415) 604-5185



# Computer Graphic Representation of Visual Space

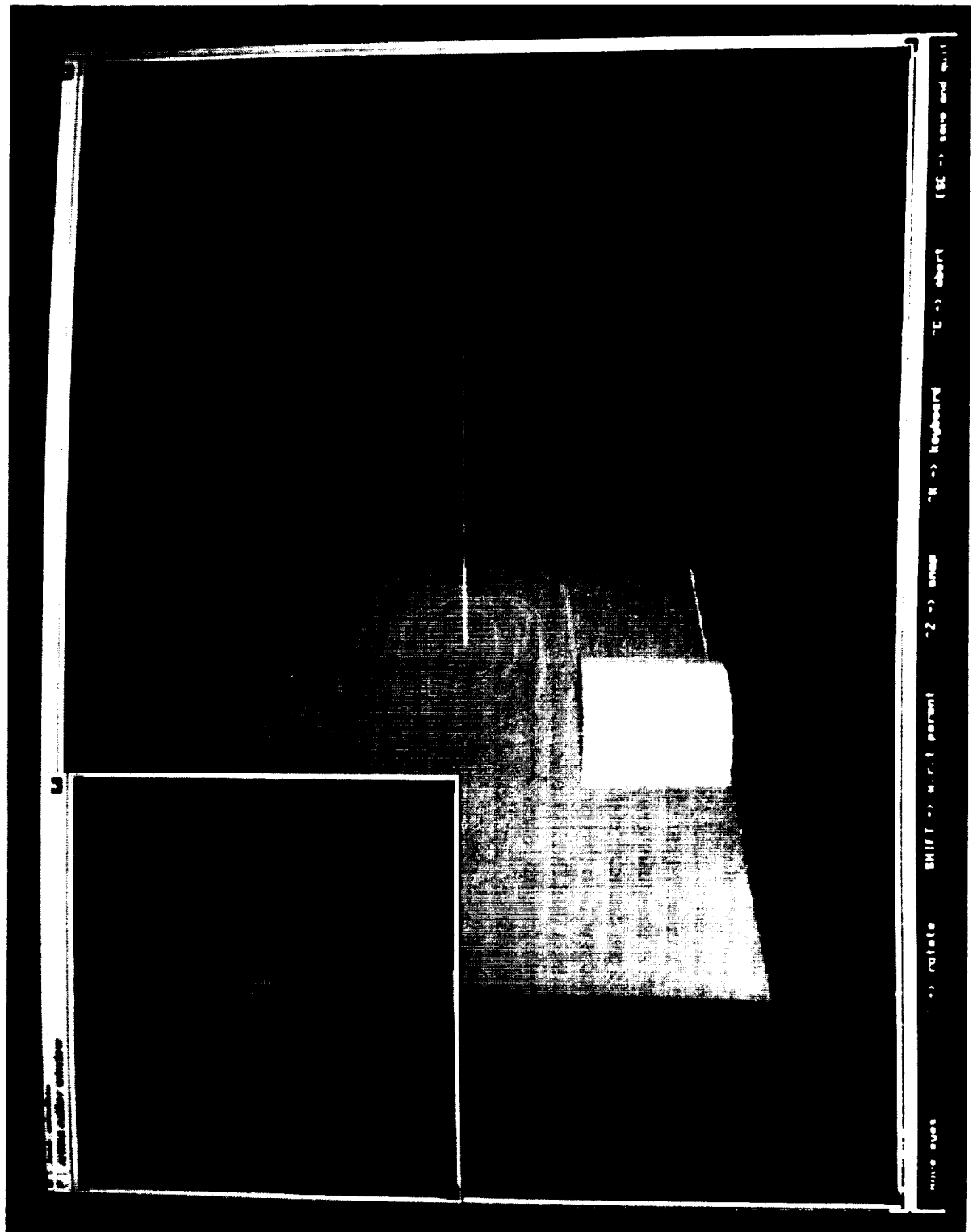

ORIGINAL PAGE IS  
OF POOR QUALITY

ORIGINAL PAGE  
BLACK AND WHITE PHOTOGRAPH

## Dynamic Anthropometric Modeling

One of the most fundamental requirements for model-based human engineering and analysis in a wide array of applications is a representation of human anthropometry and motion. A grant with Dr. Norm Badler at the University of Pennsylvania has been established to meet this need with easily created, realistic, and physically quantifiable human figure motion via an interactive computer graphics system for human modeling in a three-dimensional space environment. Major research topics within this project include (1) task simulation mechanisms that facilitate animation of human movement by developing an interface between artificial intelligence and graphic motion control; (2) reporting task simulation results with graphic animations and various workload performance measures including reach and view assessments, collision and interference detection, strength or reaction force assessment, and psychomotor task load; and (3) the use of human characteristics such as hand preference or fatigue within the task simulation.

The resulting computer program, JACK, allows the user to select different sized male and female human figures or graphic mannequins in the 5th, 50th, and 95th percentile body size based on NASA astronaut demographics. These mannequins can then be placed within a three-dimensional object environment created and stored using a number of modeling packages. Articulation is achieved using a goal-solving technique based on specifying body joint orientations or end-effector (limb) goals. Flexibility constraints have been installed to eliminate unreasonable movements. Kinematic and inverse kinematic controls are applied so that goals and constraints may be used to position and

orient the figure, with external/internal forces and torques applied to produce motion. A movement time concept based on Fitt's Law has been incorporated based on reach site distance and width.

Supporting graphic output in wire-frame, solid filled, or smooth shaded modes, key poses can be stored and interpolated for animation, allowing environmental limitations to be detected as a function of human size and movement characteristics. In addition, by attaching the "view" of the environment to the mannequin's eye, JACK displays a perspective corresponding to what the mannequin would see while moving in the environment, providing the first step toward further analysis and conclusions about object occlusion and visibility.

Begun in the fall of 1987, JACK is being further enhanced, both in house and by the developer, as an integral part of A<sup>3</sup>I's MIDAS workstation.

Technical Contact

Barry R. Smith, ARC, (415) 604-4264

**Dynamic Anthropometric Modeling**

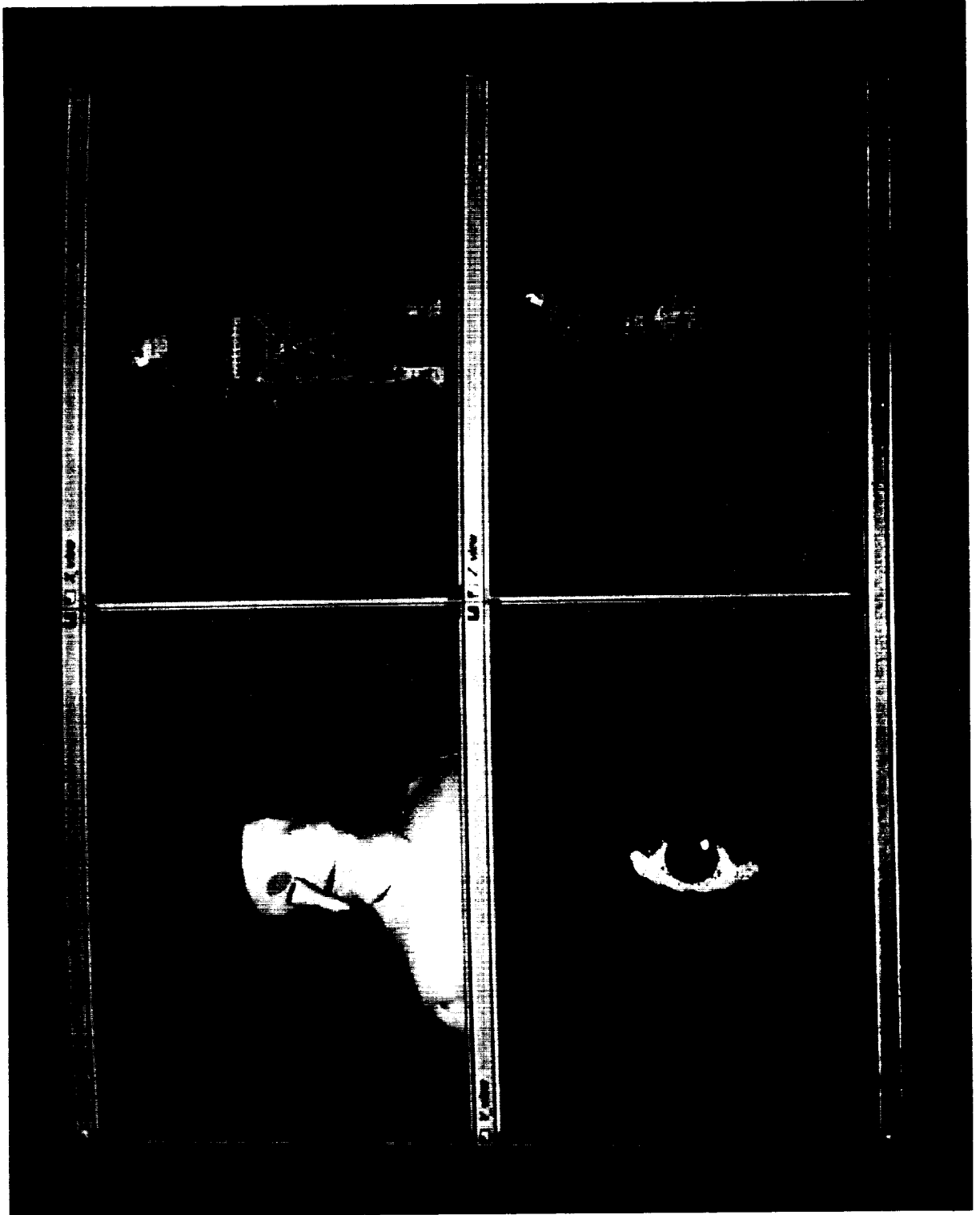

ORIGINAL PAGE  
BLACK AND WHITE PHOTOGRAPH

## Virtual Interactive Environment Workstation

Human capabilities outside vehicles and shelters will be a vital element of Space Station, Lunar base, and Mars exploration missions. Because extravehicular activity (EVA) will account for much of the human presence and robots will assist in many chores, telepresence and interactive visualization systems will provide essential crew performance enhancement capabilities.

To support NASA's mission requirements for augmented human capability, the Human Interface Research Branch (Code FLM) is continuing to develop the Virtual Interactive Environment Workstation (VIEWS). This device is a multisensory personal simulator and telepresence device consisting of a custom-built, wide field-of-view stereo head-mounted display, a custom video processor, magnetic head tracker, fiber optic gloves, magnetic gesture trackers, voice input/output, and an audio symbology generator. The VIEWS is being developed to enable greatly improved situation awareness in complex spatial environments; to enable high-fidelity telepresence for control of telerobots; to simulate workstations, cockpits, and module interiors; and to enable improved scientific visualization interfaces for exploration of planetary surface data.

The third-generation monochrome viewer and video processor electronics have been completed. Ad hoc demonstration software has been replaced by a system software library for programming the viewer, tracker, and glove. A directional acoustic signal processor, the 'convolvotron', has been designed and is being fabricated. Initial Operational Capability (IOC) of the pro-

TOTYPE system will be achieved by the end of the year. Upon reaching IOC, the hardware and software will be integrated into a stable configuration for user interface research, and generic development will end. Recently, a major documentation activity has been completed, and technology transfer activities are increasing.

Application software is under development for a joint effort between NASA Ames and NASA's Jet Propulsion Lab (JPL) in which the VIEWS will be used to provide an alternate operator interface in telerobotics supervisory control. In another project, a highly dextrous anthropomorphic end-effector under development at JPL and the Ames VIEWS will demonstrate high-fidelity dextrous telepresence between Ames and JPL.

### Technical Contact

Stephen R. Ellis, ARC, (415) 604-6147  
Michael W. McGreevy, ARC, (415) 604-5784  
Elizabeth M. Wenzel, ARC, (415) 604-6290  
Dr. James O. Larimer, ARC, (415) 604-5185

# Virtual Interface Environments

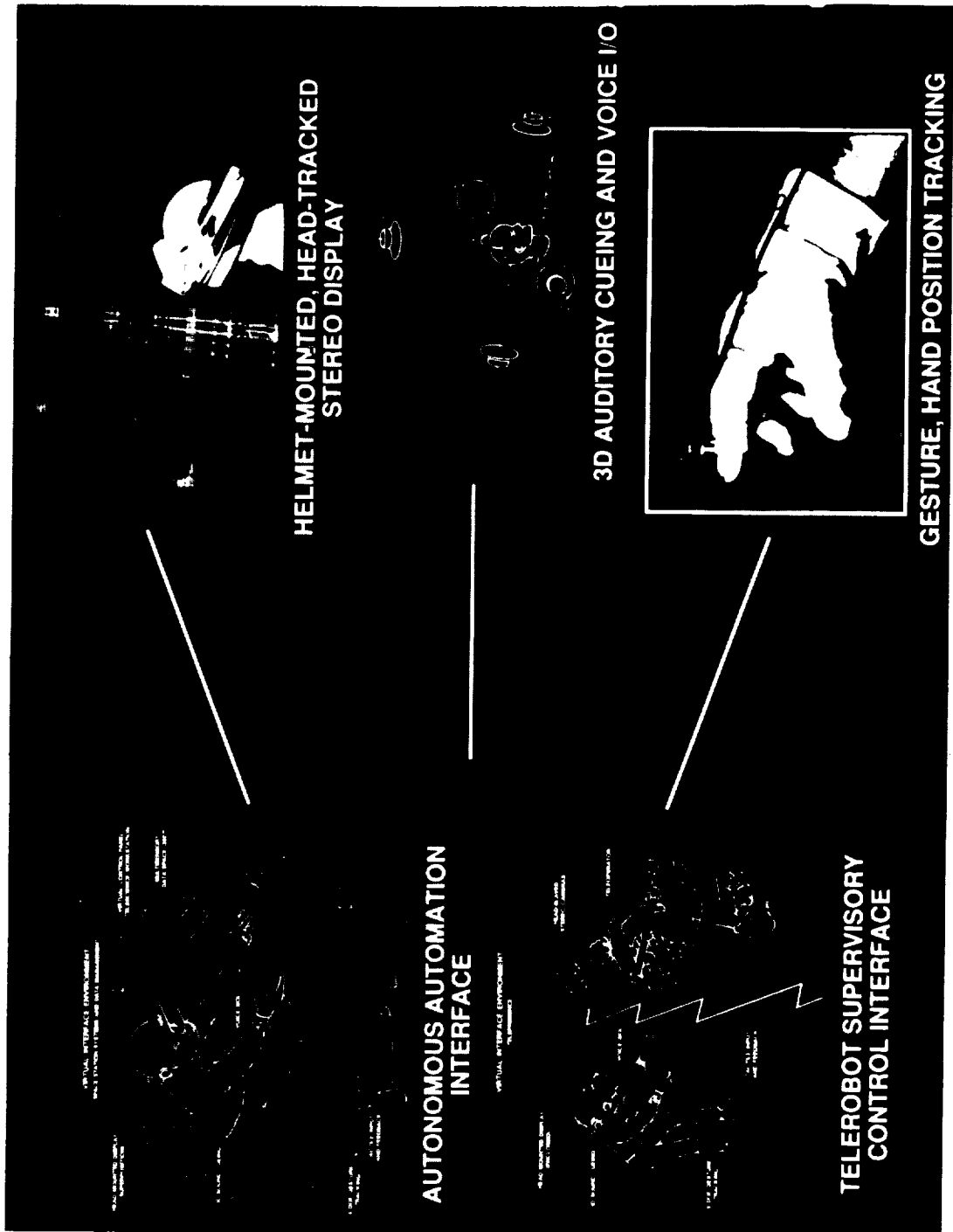

ORIGINAL PAGE IS  
OF POOR QUALITY

ORIGINAL PAGE  
BLACK AND WHITE PHOTOGRAPH

## Symbolic Operator Model

This component of the Man-machine Integration Design and Analysis System (MIDAS) is complex and continuously evolving. It currently contains two major subcomponents: the scheduling and loading models. During a simulation, this model attempts to execute assigned mission activities subject to specified constraints, state variables, and other simulation object requirements. This model accomplishes this action by (1) updating the simulated operator goal list to delete terminated or inappropriate goals; (2) examining equipment and world state variables to determine if event-response activities are required; (3) tracing the decomposition of mission goals to their lowest level, finding matching equipment operation patterns or activities that will satisfy them; (4) sorting these matched goal-activity patterns by priority; (5) interacting with the scheduling and loading operator model components as appropriate; and (6) executing these activities subject to physical resource (hand, eye, etc.) requirements, visual, auditory, cognitive, and psychomotor (VACP) load limits, and temporal/logical constraints.

This constraint-based, opportunistic model of operator scheduling behavior was developed using the blackboard architecture provided as part of the Generic Expert System Tool (GEST). The scheduler contains modular components or knowledge sources that represent individual stages in the scheduling process, with an extended task-based decomposition (a "divide-and-conquer" technique) used to partition the overall scheduling problem. It closely interacts with the MIDAS task-loading model for reasoning about resource interactions between plausible concurrent tasks.

The task-loading model is based on current research in multiple resource theory, scaling, workload, and perception. Based on attributes of the mission tasks, world state, operator, and crew station equipment, a resource classification taxonomy is used to classify individual tasks in terms of their demands on the visual, auditory, cognitive, and psychomotor processing dimensions. In addition, conflict matrices are used to describe the interactions of these resource demands across different processing dimensions and tasks. An initial version of the task-loading model has been coded in Symbolics Common Lisp.

### Technical Contact

Barry Smith, ARC, (415) 604-4264

E. James Hartzell, ARC, (415) 604-5743

Irving C. Statler, ARC, (415) 604-6938

# Scheduler for the MIDAS Operator Model

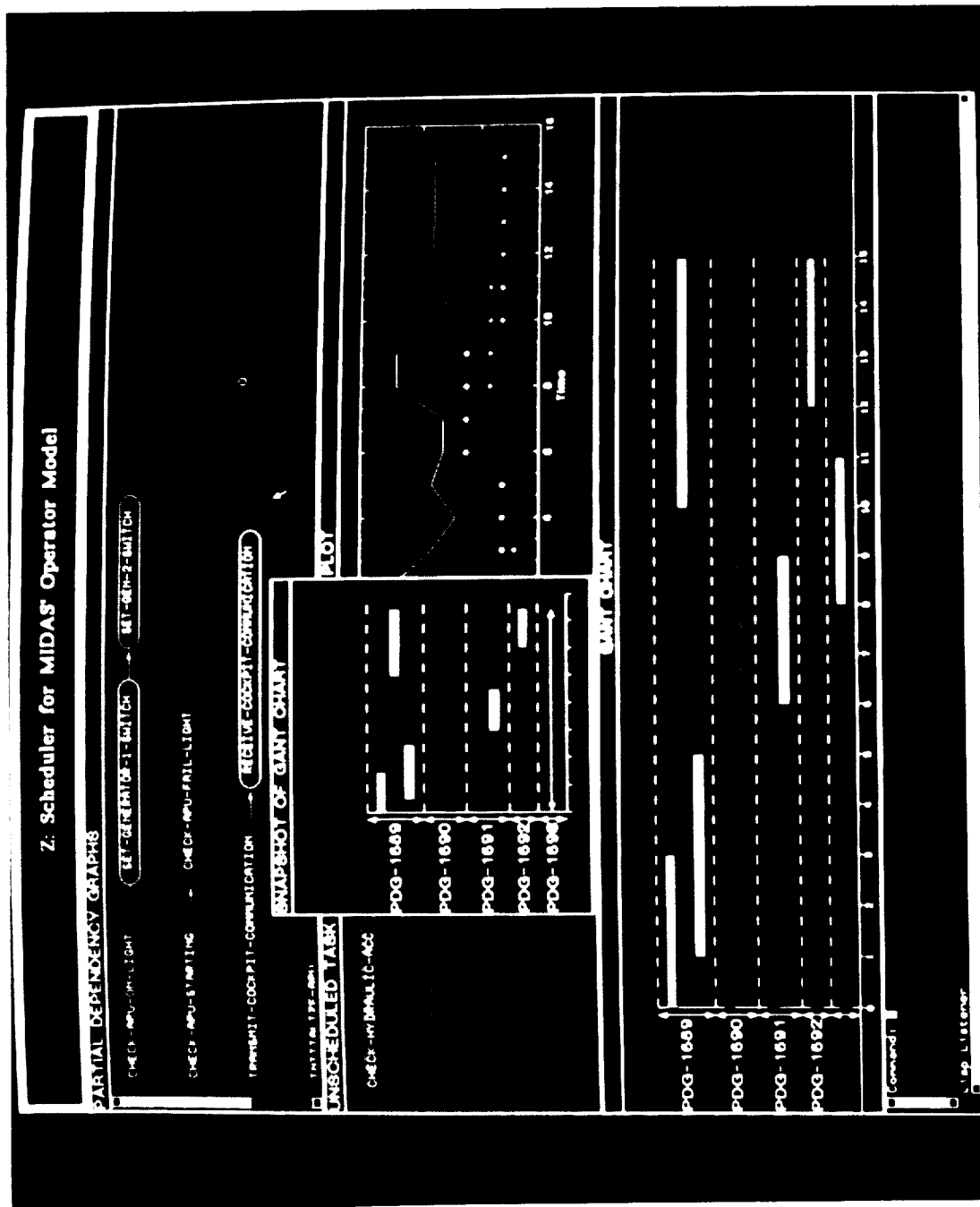

## Visualization for Planetary Exploration

The objective of this project is to develop a terrain visualization and exploration system to allow NASA users, such as astro-geologists and rover vehicle managers, to observe and analyze planetary terrain features on a highly interactive, color, three-dimensional display graphic system.

RIACS is supporting the Visualization for Planetary Exploration (VPE) project, directed by Dr. Michael McGreevy, Aerospace Human Factors (Code FLM). RIACS support consists of computer system design plus software design and development. The VPE project is developing a graphics-workstation-based terrain visualization and exploration system, which generates color 3-D images based on actual planetary terrain elevation and imagery data. Users may explore the terrain dynamically by changing the viewing position. The system will include "virtual reality" capability by means of a stereo head-mounted display to provide the user with a full-field-of-vision scene manipulated by a helmet. This project will also create and analyze tools that enable research into the human factors of geological exploration.

Digital terrain data of Mars has been obtained from U. S. Geological Survey (NSSDC) and collected into a VPE data base. We can display Mars terrain with elevation-coded color, sun illumination shading, and texture mapping. The workstation user can select a region of the planet, render a 3-D view of the region, and then "fly" around in the terrain via workstation input controls (mouse). Image detail can be varied to trade off animation update time for image realism. The terrain-rendering software has been partially interfaced to the helmet-mounted display. A

method for synthesizing higher resolution terrain data from actual elevation data has been developed and tested with Mars data. All software is written for X windows and UNIX environments.

Users will be able to explore planetary terrains with a high degree of interaction (as opposed to precomputed movie animations). Realism will be higher than that available in current or previous systems as a result of the "virtual reality" methods employed. Although the system will not provide the same capabilities as commercial image-generation systems (flight simulators), it is being developed on a workstation that costs an order of magnitude less than such systems and, thus, will be practical for installation directly in a science or project laboratory at one or more centers. The plan is to continue system development.

Technical Contact

Lewis E. Hitchner, ARC (RIACS), (415) 962-7764



## 2-D and 3-D Topographic Presentation of Viking Data

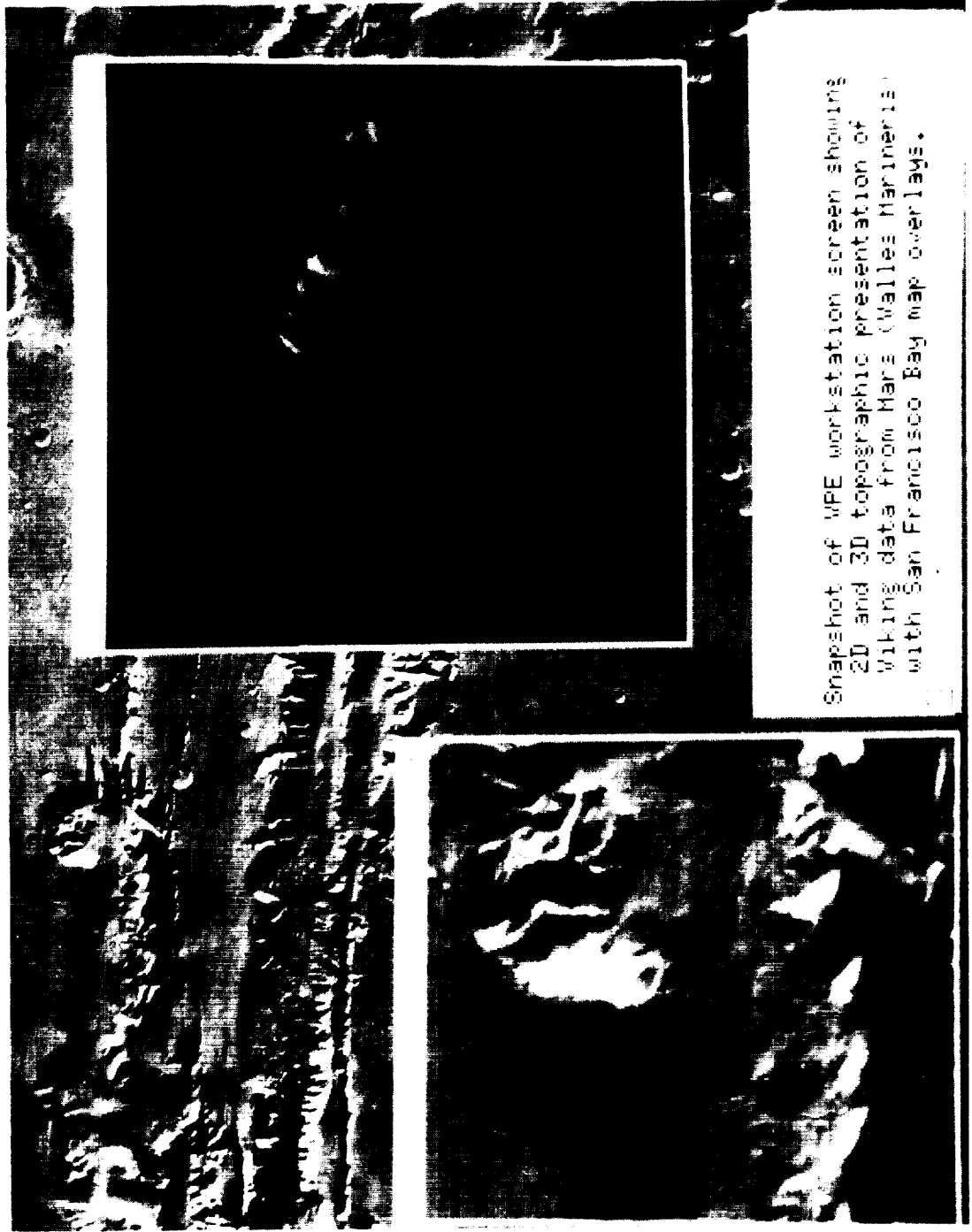

Snapshot of WPE workstation screen showing  
2D and 3D topographic presentation of  
Viking data from Mars (Valles Marineris)  
with San Francisco Bay map overlays.

ORIGINAL PAGE IS  
OF POOR QUALITY

ORIGINAL PAGE  
BLACK AND WHITE PHOTOGRAPH

## Virtual Workstation for Planetary Exploration

The objective of this program is to conduct research and development of crew interfaces for in-space terrain exploration systems. The approach is to (1) review mission operational experiences, mission constraints and opportunities, and the state of the art in exploration technology; (2) investigate user behavior and requirements; and (3) enlist interdisciplinary expertise to develop, implement, demonstrate, and evaluate advanced crew interfaces. Field studies have been conducted in desert terrain to understand operations central to planetary surface exploration. In addition, a planetary terrain visualization testbed is under development to support focused user-interface research. This powerful computer system provides dynamic interaction with planetary terrain data (currently Mars and Earth, but easily applicable to Venus, Earth's moon, or other planetary bodies).

The OAET Virtual Workstation is a powerful user interface device for NASA's mission-oriented applications, including computational fluid dynamics, planetary data visualization, in-space telepresence, and Space Station telerobotics. Beyond these applications, the Virtual Workstation is also a uniquely useful user-interface research device. Using head-tracked head-mounted displays, the Virtual Workstation provides the user with a vivid experience of three-dimensional space. It can be used with computer graphics systems as a personal simulator, surrounding the user with a virtual interactive environment. Alternatively, it can utilize helmet-attached cameras and other sensors to provide telepresence. In either case, an instrumented glove may be used to detect hand shape and position to enable the user to manipulate objects in computer generated or remote environments.

Preliminary discussions with planetary geoscientists indicate there is a strong scientific interest in the development of Virtual Workstation technology for planetary surface telepresence. A leading concept is to extend the reach of human exploration beyond the perimeter of manned EVA by use of telepresence from centrally manned bases to numerous unmanned rovers. Geoscientists with decades of experience in field work believe that human presence contributes a tightly coupled and essential interplay of cognitive, perceptual, manipulative, and locomotor skills that can complement automated rover operations. By using telepresence, these unique human skills may be applied over a greater area at an earlier date.

The Virtual Workstation is of interest to the Office of Space Flight for possible use on Space Station *Freedom*. Under the Advanced Development Program, a study is under way to determine the design accommodations, also known as "hooks and scars," that may be required to support eventual use of the OAET Virtual Workstation on board Space Station *Freedom*. The utilization of this technology for Space Station automation and telerobotics is currently being studied under the OAET Automation and Robotics program, in cooperation with Dr. Guy Boy of NASA Ames Research Center.

### Technical Contact

Michael W. McGreevy, ARC, (415) 604-5784

Stephen R. Ellis, ARC, (415) 604-6147

# Virtual Workstation for Planetary Terrain Visualization

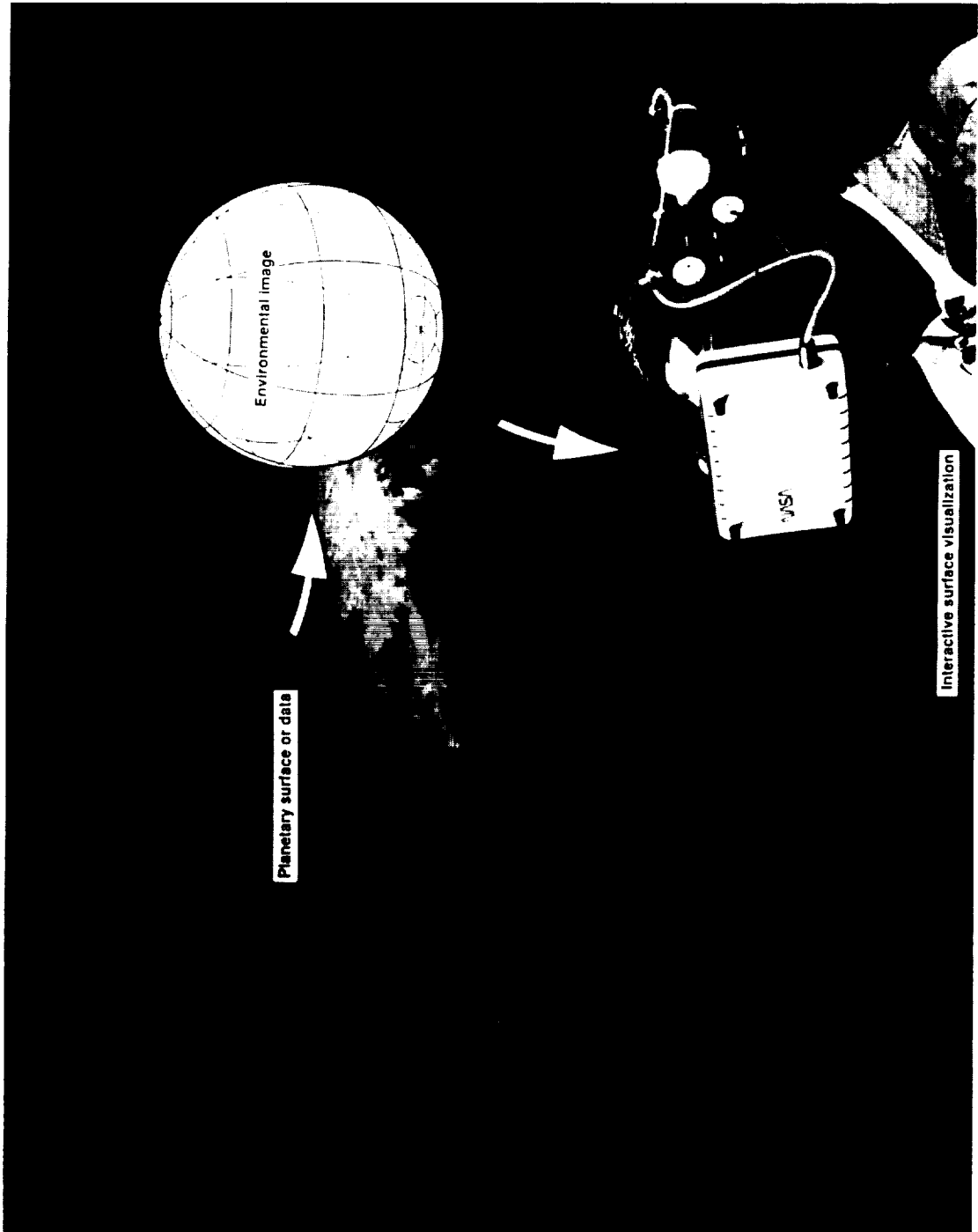

ORIGINAL PAGE IS  
OF POOR QUALITY

ORIGINAL PAGE  
BLACK AND WHITE PHOTOGRAPH

## EVA Aids

The objective of this research is to determine what information and capabilities should be available to an Astronaut in Extravehicular Activity (EVA). Crucial work in servicing and repairing satellites must be done in EVA. When an astronaut is working outside of the Shuttle, for instance, the resources within the Shuttle are not available. With no direct access to flight data files, computers, or the direct link to mission control, careful consideration must be given to identifying the aids required by the astronaut to service and repair a satellite.

Details of suit operation, procedures for repair, and drawings to show the astronaut what he or she is supposed to look for are key elements to be examined. A Helmet Mounted Display (HMD) can provide this information by projecting it onto the upper part of the EVA helmet, where it is out of the astronaut's primary field of view. Another option to be considered is a cuff checklist. Currently, this cuff checklist is made of paper, which is hard to control and update. A new project is under way to develop an electronic cuff checklist in which data would be displayed on an LCD screen, and paging would be controlled by buttons or voice command.

Voice command for EVA has received considerable attention because it allows the astronaut to call up new information while leaving his or her hand free. One of the more serious problems with voice command is a tendency for the voice recognizer to interpret and respond to an extraneous word as one in its vocabulary. This happens because the EVA astronaut often maintains an ongoing conversation with the crew in the shuttle, and only occasionally would need

to use the voice command system. Experiments are being conducted to determine parameters of voice recognition that would allow the software to distinguish a valid command from conversation with the shuttle.

Other tests have been run using the hard upper torso and helmet space suit, (with its attendant airflow noise) which point to a particular placement of the microphone and which required high confidence scores for voice recognition to effectively eliminate the tendency of the voice recognizer to respond to extraneous conversation and to respond only to voice command.

Point of Contact

Barbara Woolford, JSC, (713) 483-3701

## EVA Performance Aids



- VOICE INPUT IS TESTED FOR FALSE RECOGNITIONS

- MICROPHONE PLACEMENT IS STUDIED FOR VOICE COMMAND RECOGNITION ACCURACY

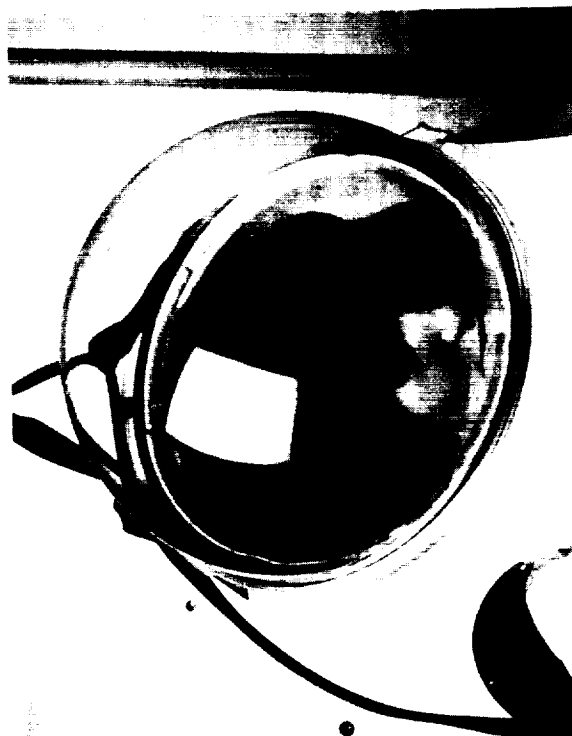

ORIGINAL PAGE IS  
OF POOR QUALITY

ORIGINAL PAGE  
BLACK AND WHITE PHOTOGRAPH

## Human-Computer Interaction

The study of human-computer interaction focuses on the avenues of communication between the crew and spacecraft systems. Research in the JSC Human-Computer Interaction Laboratory (HCIL) emphasizes that the crew and spacecraft systems form an integrated, multiagent system and, through the design of human-computer interfaces, attempts to find new ways in which that integrated system can function more effectively. In this manner, the important goals of the integrated crew/spacecraft system are reached more efficiently, with less chance of the occurrence of anomaly. Two of the more important areas in which the HCIL has made steady progress toward this end are in the electronic display of procedures and in the study of interfaces to intelligent (expert) systems.

The HCIL has a mature line of research investigating the most appropriate form of electronically presenting procedural information. The results of several experiments have allowed the HCIL to formulate general guidelines concerning the format, context, and level of detail at which to present procedural information. Based on the results of these experiments, the HCIL is currently building a system for demonstrating the optimal method of electronically displaying procedures. Also, the HCIL is now interested in investigating possibilities for the adaptive display of procedures, so that the interface may alter the contents and format of procedural information based on a crew member's interactions or on the task.

Interfaces to intelligent systems is a new HCIL research area. The laboratory has made significant progress in its initial investigation of many issues particularly relevant

to HCI with intelligent and expert systems. Three experiments investigated the best way to code the large amount of data returning from an expert system. These experiments have demonstrated the valuable use of many coding techniques, while also indicating the limited use of color as a symbolic language. Research investigating the optimal level of detail for the presentation of expert system explanations has been completed. Finally, an experiment examining the relative effectiveness of the Space Station's automated thermal control system (TEXSYS) displays was carried out, emphasizing expert versus novice performance. The results showed that the particular display that is best for presenting expert system data depends on the kind of system state that is indicated by that data. Based on these results, four more experiments investigating expert system fault management, display format, and expert system function allocation have been planned. The main goal of this research is to provide designers of intelligent system interfaces with guidelines for HCI design.

Technical Contact

Marianne Rudisill, JSC, (713) 483-3706

# Human-Computer Interaction

- DEFINE INFORMATION NEEDED BY USER
- DETERMINE MOST EFFECTIVE PRESENTATION
- DESIGN NEW RESEARCH TECHNIQUES FOR FUNCTION ALLOCATION



HUMAN-COMPUTER INTERACTION

- COGNITIVE AND PERFORMANCE MODELING USED TO MAKE PREDICTIONS ABOUT USER INTER-FACE

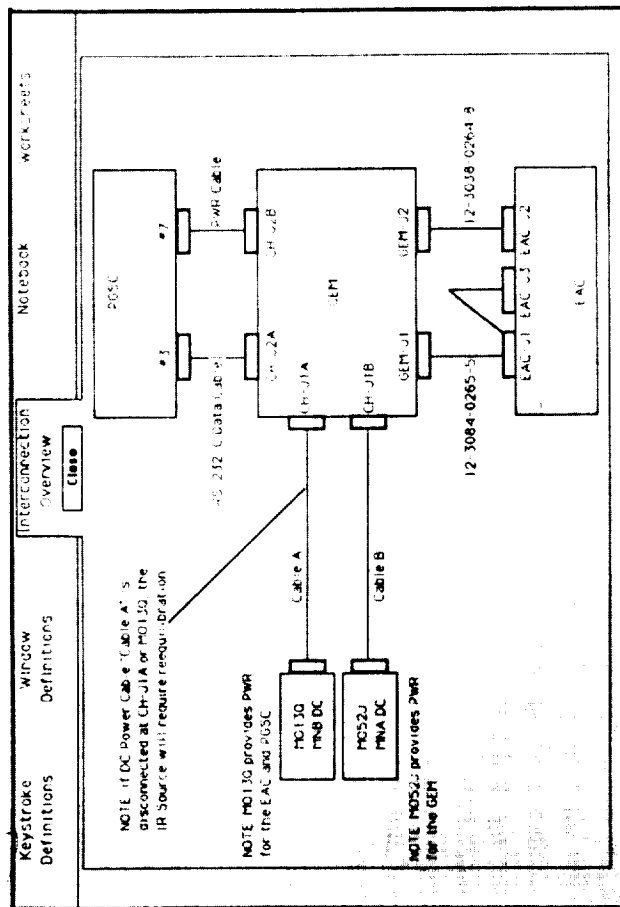

- ELECTRIC DESIGN OF PROCEDURES PROTOTYPE

## Interface Design for User Control of Intelligent Systems

The objective of this project is to increase user control and understanding of intelligent systems for dynamic monitoring and fault management, by developing supporting user interface design technologies and processes. This year, a proof-of-concept prototype of a user interface development system and methodology has been completed. The system can be used to design interfaces for intelligent systems for fault management that use schematics, diagrams, and models of the structure and function of the managed system.

The proof-of-concept prototype is designed to support interface prototyping and design of intelligent systems for effective human interface. The software has been demonstrated using a fault management scenario for a space thermal control system, in which a model-based intelligent system shares the fault management task with the human operator. The prototype illustrates several desirable capabilities for developing user interfaces: (1) separation of the user interface from the intelligent system; (2) object-oriented data-model layer and architecture to handle information transfer between user and intelligent system; (3) early consideration of information requirements from intelligent system and user; and (4) integration of intelligent system interface with conventional software, to handle embedded intelligent systems.

Another major part of the project has been to develop qualitative models for engineered systems to support effective user interface. These system models are used to support user understanding of the status of the managed system, explanations of system behavior, and concrete

interactions between the user and the intelligent software. Modeling work was completed this year. Results include a set of reusable qualitative model parts for core phenomena in engineering thermodynamics, which can be combined to build models for such systems as refrigerators, steam plants, and space thermal control systems. Compositional modeling techniques have been developed for integrating qualitative and quantitative model information and several optional types of detail that are controlled by explicit modeling assumptions. Thus, several types and levels of explanation can be supported.

A lessons-learned report, "Graphic Interfaces to Intelligent Fault Management Systems: Issues and Guidelines," summarizes what has been learned in this project so far. A proposal for a follow-on project to apply the results of the prototype work in space programs has been developed. This project would produce requirements documents for User Interface Development Systems and Intelligent System Development Environments to support effective user interface design for intelligent systems.

Technical Contact

Jane T. Malin, JSC, (713) 483-2046



# Design for User Control of Intelligent Systems

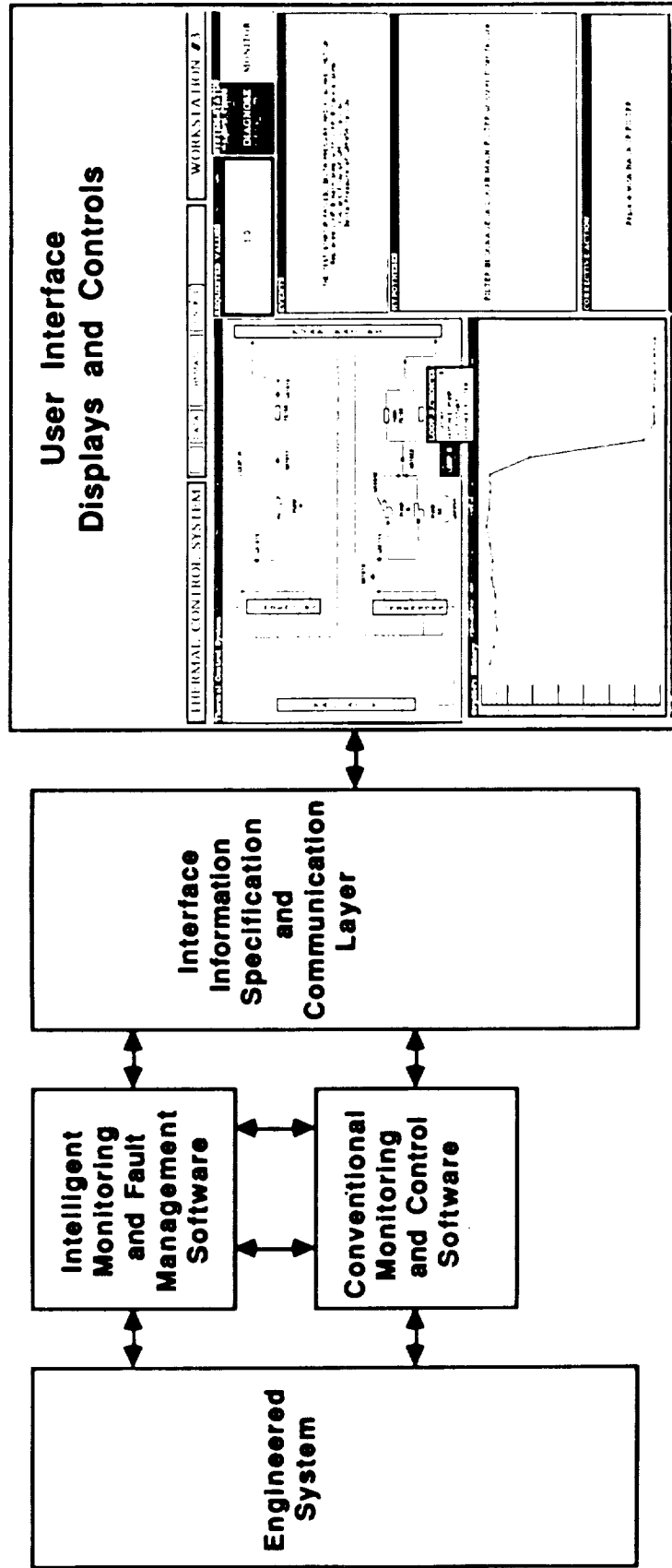

**USER CONTROL AND UNDERSTANDING**

**DESIGN METHODOLOGY AND SOFTWARE AND SYSTEM ARCHITECTURE**

## Strength and Motion Measurement

The support for empirical studies of strength and motion has contributed greatly to both the theoretical modeling efforts and the issues that arise in actual operations. During the year, the researchers on this project have assisted in comparing performance capabilities of the two zero pre-breathe suits, have assisted in qualifying a shoulder bearing for flight, have worked on determining loads imparted to a foot restraint or structure by an EVA crew member doing a task, and have studied the effect of space suits on strength. One key study that was very significant to operational requirements was the analysis of the effect of the new launch/entry suit on performance in the cockpit.

Crew members aboard the Space Shuttle are subjected to accelerations during ascent that range up to 3 g in the chest-to-back direction. Despite the experience of 33 missions, no truly quantitative reach study using actual crew equipment has ever been conducted. This lack of reach performance data has resulted in uncertainty regarding emergency procedures that can realistically be performed during actual Shuttle ascent versus what is currently practiced in ground-based simulators. This uncertainty has increased with the introduction, on STS-26, of the current Launch Entry Suit (LES). There were concerns that the survival equipment incorporated into this suit would further degrade performance during ascent accelerations.

A study was developed to quantify the crew's performance while wearing the LES under both a 1-g and 3-g load. Four veteran astronaut pilots, three veteran mission specialists,

and four naive airmen were test subjects for this study. Quantitative measurements were obtained from photogrammetric data captured while each subject rode the Brooks Air Force Base centrifuge and performed a variety of reach tasks. To date, the analysis of these data has demonstrated that Shuttle crews in training can expect to maintain all of the overhead reach capability evident in good simulator runs and suffer only moderate degradation in the forward reach performance during the launch phase of an actual Shuttle mission. Analysis of visual performance and 6-g data is in progress. Potential Space Station applications of this data include predicting reach performance during Assured Crew Return Vehicle (ACRV) operations.

Technical Contact

Tandi M. Bagian, JSC, (713) 483-3699

## Launch/Entry Suit Reach Measurement

- ASSESS PERFORMANCE AT 1-G AND 3-G
- MEASURE REACH BY 3-D VIDEO TRACKING
- ANALYZE DATA TO DETERMINE REACH LIMITS
- APPLY RESULTS TO:
  - SHUTTLE
  - SPACE STATION
  - ASSURED CREW RETURN VEHICLE



LAUNCH SUIT IN CENTRIFUGE

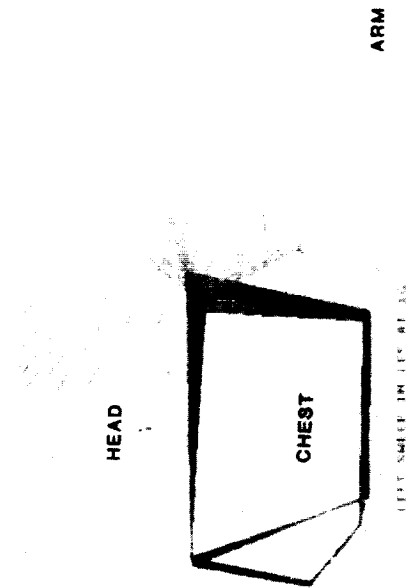

SWEEP OF LEFT ARM AT 1-G

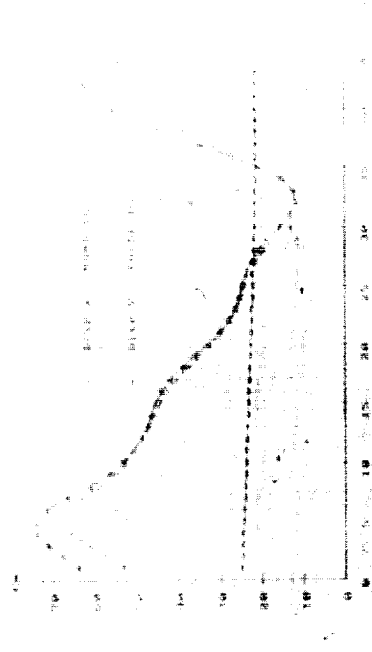

GRAPHICAL REPRESENTATION OF JOINT POSITION DURING REACH SWEEP

## Strength and Motion Modeling

---

The ability to predict the force that an astronaut can exert on a piece of equipment, or on part of a structure, is important to human factors engineers and to mission planners. It enables them to specify loads that the equipment must sustain, and to predict how the crew members will handle large masses. For example, this year a trash compactor was designed for use in the Shuttle. It was designed to be manually operated both to save power and to provide exercise for the crew. The design engineers needed to know how much force a relatively weak astronaut could exert so they could determine the mechanical amplification needed, and they needed to know how much force a relatively strong astronaut could exert so they could build the equipment to be sturdy enough to withstand the likely high loads.

A new capability in PLaid, the human factors computer-aided design system, will permit such calculations in the future. This year, strength data were collected for single joint motions through a range of angles, at varying velocities. Polynomial equations were fit to the data and stored in the program's data base. Then a motion, that of turning a ratchet wrench, was simulated by the software. For each point in the wrench's rotation, the position of the crew member, which was required to move the wrench to that angle, was calculated. The resultant angles were used to determine, from the empirical curves, the force applied by the astronaut at each joint. The resultant force, determined by vector addition, was calculated and plotted in two ways. One way was a series of bar graphs shown on the screen with the motion, which gave the force predicted for each joint, and the resultant force. The other way was

a color-coded curve showing the entire range of motion with the force determining the color at each point.

The model will be validated this year, and data will be collected from more subjects so that a range of values, rather than just one, can be predicted. In addition, a more general class of motions will be allowed. While the present algorithm is designed for rotation of an object, there are many other patterns of motion possible. The animation capabilities of PLaid permit showing quite complex movements with only a few inputs by the analyst. These animation capabilities will be tied to the force calculation model so that any motion can be easily simulated.

Technical Contact

Barbara Woolford, JSC, (713) 483-3701

# Biomechanical Modeling

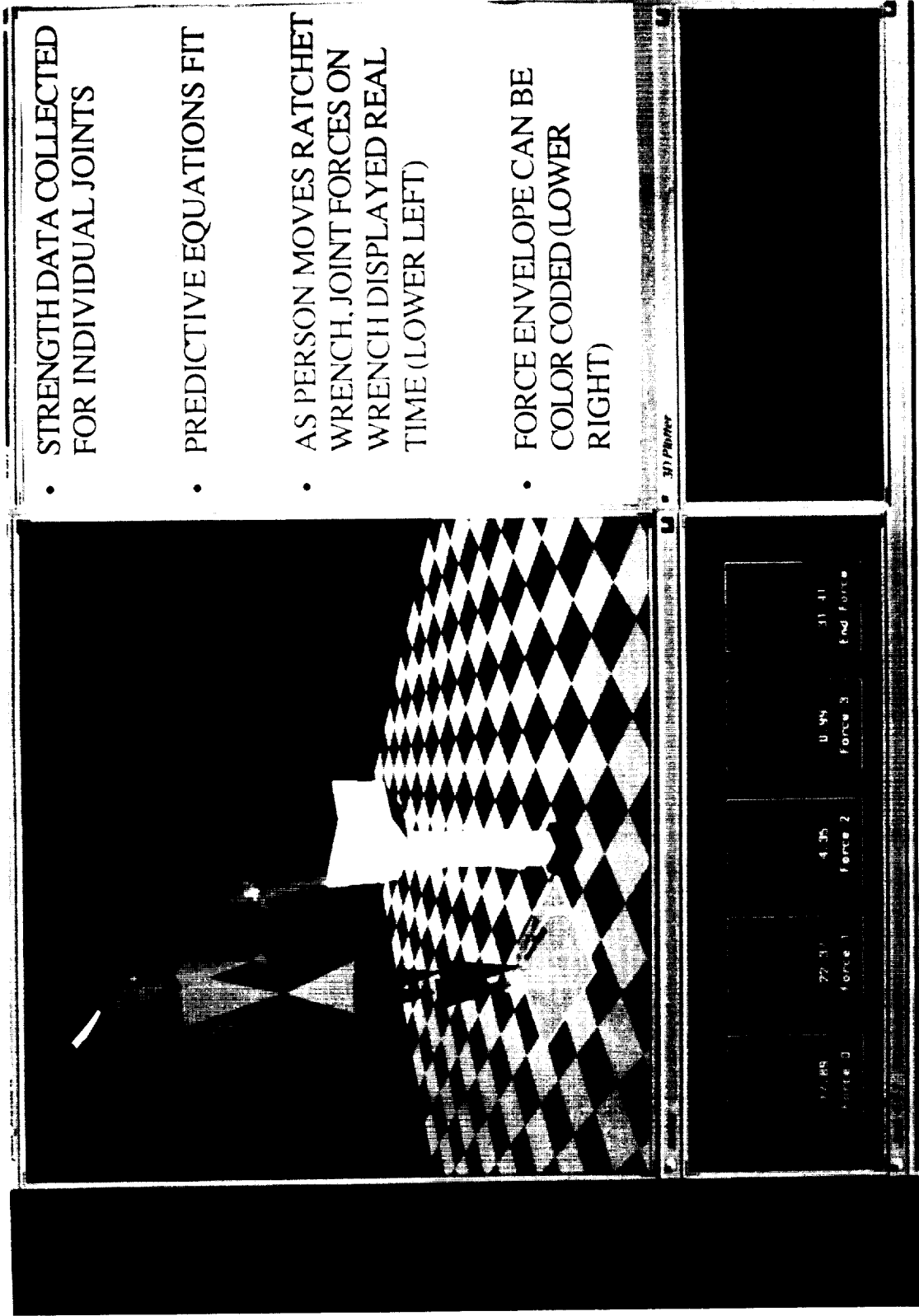

- STRENGTH DATA COLLECTED FOR INDIVIDUAL JOINTS
- PREDICTIVE EQUATIONS FIT
- AS PERSON MOVES RATCHET WRENCH, JOINT FORCES ON WRENCH DISPLAYED REAL TIME (LOWER LEFT)
- FORCE ENVELOPE CAN BE COLOR CODED (LOWER RIGHT)



## **Sensor Systems**

The objective of the Sensor Technology Program is to provide necessary expertise and technology to advance space remote sensing of terrestrial, planetary, and galactic phenomena through the use of electromagnetic and electro-optic properties of gas, liquid, and solid-state materials technology.

The Sensor Technology Program is divided into two subprograms: a base research and development part and a Civil Space Technology Initiative (CSTI) part. The base research and development consists of research on artificially grown materials such as quantum well and superlattice structures with the potential for new and efficient means for detecting electromagnetic phenomena. Research is also being done on unique materials and concepts for detector components and on devices for measuring high-energy phenomena such as UV, x-, and gamma rays that are required observables in astrophysical and solar physics missions.

The CSTI program is more mission driven and is balanced among four major research and development disciplines: (1) detector sensors; (2) submillimeter wave sensors; (3) lidar/DIAL sensors; and (4) cooler technology. The first discipline plans to develop large spatial imaging format arrays in the near (1 - 30 mm wavelength) and far (30 - 200 mm wavelength) infrared portions of the electromagnetic (EM) spectrum. These goals are crucial to enable spaceborne remote sensing for the various terrestrial, planetary, and astrophysical missions. The submillimeter discipline is dedicated to developing the technology to enable heterodyne receiver instruments for remote sensing in the 300 to 3000 GHz frequency regions of the EM spectrum with a focus on developing local oscillators, frequency mixers, and quasi-optical technology in this region. Backward wave oscillators, lasers, and quantum well devices may also have potential as oscillators. In the third area, DIAL/lidar (DIAL stands for Differential Absorption Lidar, and lidar means light detection and ranging) consists of research on techniques for enabling active remote sensing in which a coherent source such as a laser is used to probe the environment. Research is concentrated on technology for obtaining tunable, frequency stable, and pure space qualifiable lasers. Finally, in the last discipline, research is focusing on technology to enable cryogenic coolers in the Kelvin to sub-Kelvin temperature regions in support of efforts in the detector and submillimeter wave sensor thrusts. Work includes research on various cooler concepts such as the pulse tube, adiabatic, Helium 3, and zero-gravity refrigerators and their corresponding component development.

Program Manager: Ramon P. De Paula  
NASA/OAET/RC  
Washington, DC 20546  
(202) 453-2748

## Improved Low-Temperature Readouts for Astronomical IR Detector Arrays

The performance of integrated infrared (IR) detector array technology is commonly limited by the cryogenic electronics required to read out these arrays. In hybrid IR arrays, these electronics are indium-bump-bonded to a detector substrate, and the electronics must operate at the detector temperature, which can be 2 K or lower. In a pioneering development project, supported by OAET, OSSA (Space Infrared Telescope Facility, SIRTf), and the University of Hawaii, state-of-the-art, low-temperature design techniques have been employed to design readouts that should dramatically improve overall low-temperature (< 10 K) IR focal plane performance in SIRTf. These devices will allow measurements of basic low-temperature field-effect transistor (FET) parameters to be made, which should uncover the fundamental reasons why achieved low-temperature FET noise performance is commonly 3-5 times worse than predicted FET noise.

Valley Oak Semiconductor (Westlake Village, California) is developing the designs and layouts for this project, based on their dramatic success with 70 K arrays for the second-generation Hubble Space Telescope IR spectrometer. The basic approach is to produce n- and p-type metal-oxide semiconductor FETs (MOSFETs) on a thin (2  $\mu\text{m}$  or less), lightly doped epitaxial layer. The epitaxial doping of about  $2 \times 10^{14} \text{ cm}^{-3}$  is about 25 times lower than that used for room-temperature applications; this will allow the layer to remain fully depleted even at very low temperatures. This approach is expected to eliminate the excess  $1/f$  noise, anomalous current-voltage characteristics, and hysteresis seen in earlier devices operated at < 10 K.

The layout includes a large number of test structures. Included are individual FETs, in which the width-to-length ratio, oxide type (conventional  $\text{SiO}_2$  or oxynitride), oxide thickness (250 or 150 Å), epi doping, and p-well doping are all parametrically varied. These individual FETs are also grouped into basic "unit cell" test circuits, the configuration that connects to individual detector array pixels. To establish producibility and yield issues, a series of arrays of these FETs will be fabricated: a  $1 \times 32$  array (applicable to the SIRTf photometer and spectrograph), and  $128 \times 128$  and  $256 \times 256$  arrays (applicable to the SIRTf camera and spectrograph and the University of Hawaii instruments).

The new devices are being produced in the state-of-the-art TRW foundry, which accommodates 1.25  $\mu\text{m}$  design rules. Their low-pressure silicon epitaxial reactor is ideally suited for producing the epi layers, and their novel "retrograde" p-well provides a base for an n-on-p FET structure which does not freeze out below 10 K. Devices will be available in late August 1990, and testing at a number of SIRTf institutions (including ARC, GSFC, JPL, U. Arizona, U. Rochester, Cornell U., Santa Barbara Research Center, Rockwell International, and Cincinnati Electronics) will commence shortly thereafter.

Technical Contact

Craig R. McCreight, ARC, (415) 604-6549



# Improved Low-Temperature Readout Electronics for IR Detector Arrays

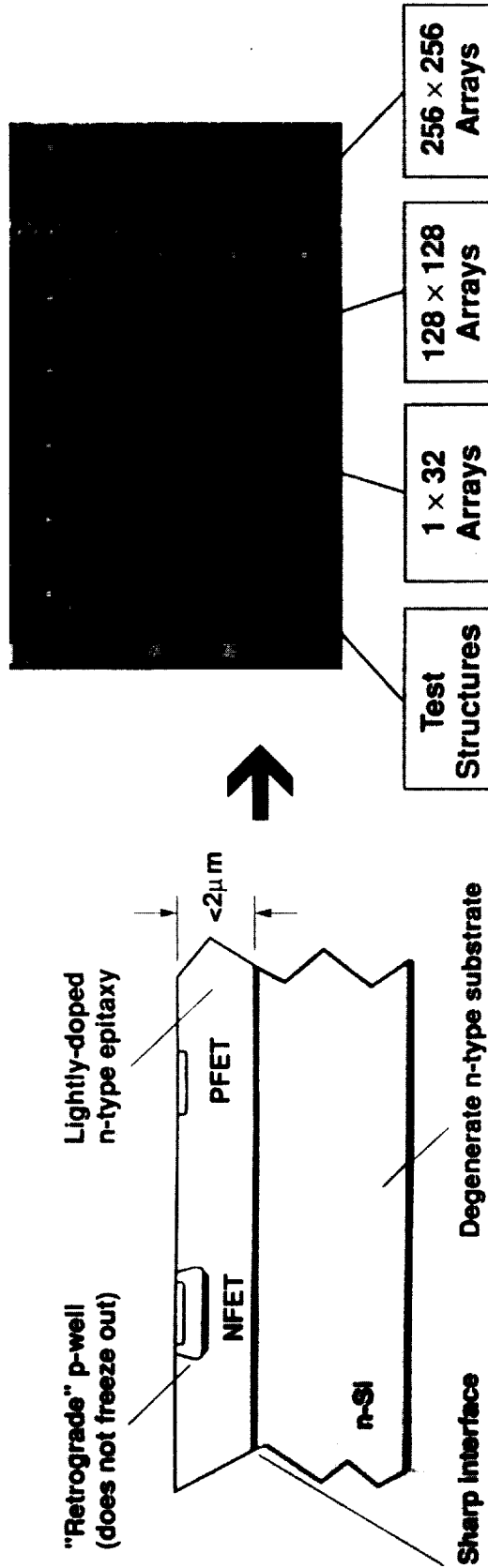

Goal: Well-behaved, low-noise common readouts for SIRTf instruments

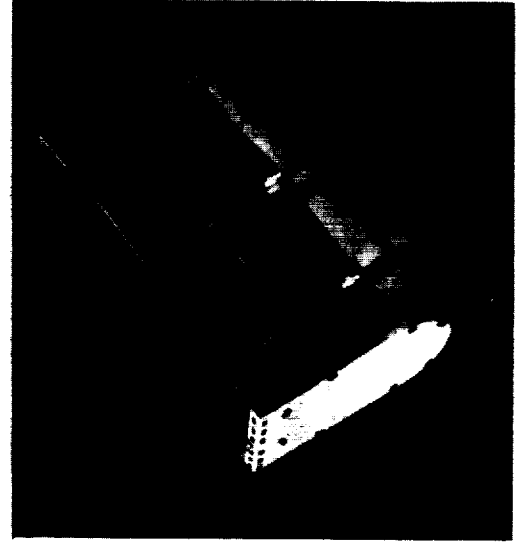

- Design by Valley Oak Semiconductor; Fabrication at TRW VHSIC foundry
- Novel low-doped epitaxial structure yields:
  - No freezeout even at temperatures  $< 10$  kelvin
  - 2-3x lower noise
  - 2x higher density
  - Improved radiation hardness
  - Simple circuit (source-follower)

## Space Qualified $^3\text{He}$ Cooler

The objective of this project was to develop and flight test a space qualified cooler for cooling infrared sensors to temperatures below 0.3 K. Development progressed from a level 1 technology (basic principles observed) to a level 7 technology (in-space demonstration).

The previous technology as used on IRAS (Infrared Astronomical Satellite) and COBE (Cosmic Background Explorer) only allowed cooling to about 1.5 K. The performance of infrared bolometers improves as  $T^{6/2}$ . Hence their sensitivity will increase by a factor of 50 by cooling to 0.3 K. Other applications include the study of critical phenomena at the  $^3\text{He}/^4\text{He}$  tricritical point in the absence of gravitational mixing (0.87 K) and the optimization of high stability clocks for navigation and relativity experiments (0.5-0.8 K).

Cooling is the result of evaporation of a liquid cryogen ( $^3\text{He}$ ). A means of confining the boiling liquid in the

absence of gravity had to be found and demonstrated. Surface tension was used to confine the liquid cryogen in a porous ( $\sim 20 \mu$  pores) cooper matrix. This technique was perfected in a series of laboratory demonstrations using -1 g. During these tests the liquid was held at the top of a chamber by surface tension. The surface tension forces were strong enough to contain the boiling cryogen while gravity tried to pull the liquid out. A qualified flight cooler was built and successfully flown on a sounding rocket in the fall of 1989. The cooler operated normally during launch and during the 10 minutes of 0-g in flight. The evaporated cryogen is pumped away with a charcoal sorption pump.

A portion of this work was done at the University of Oregon and at the University of California at Berkeley

Technical Contact  
Peter Kittel, ARC, (415) 604-4297

# Sub-Kelvin Cooler Technology <sup>3</sup>He Cooler

**Space Qualified Sub-Kelvin Cooler for  
Infrared Observations  
Basic Physics Experiments in 0-g**

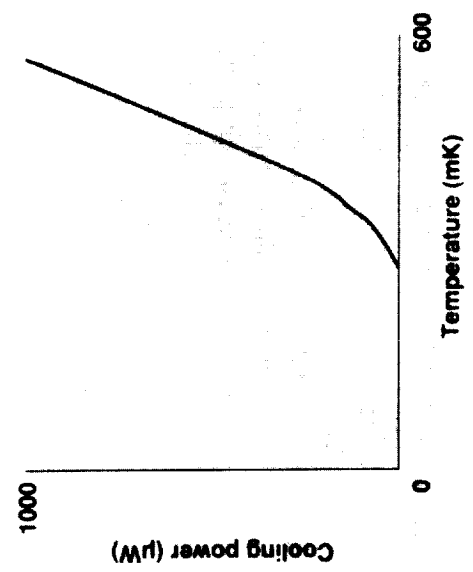
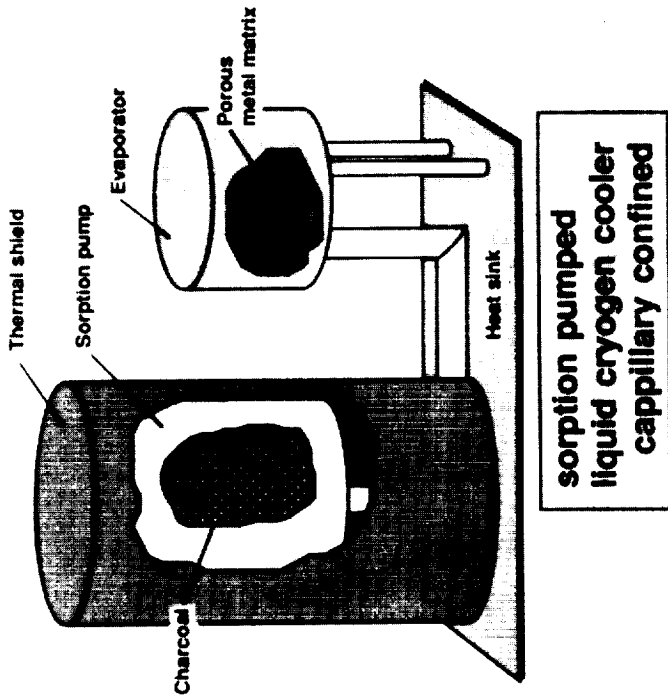
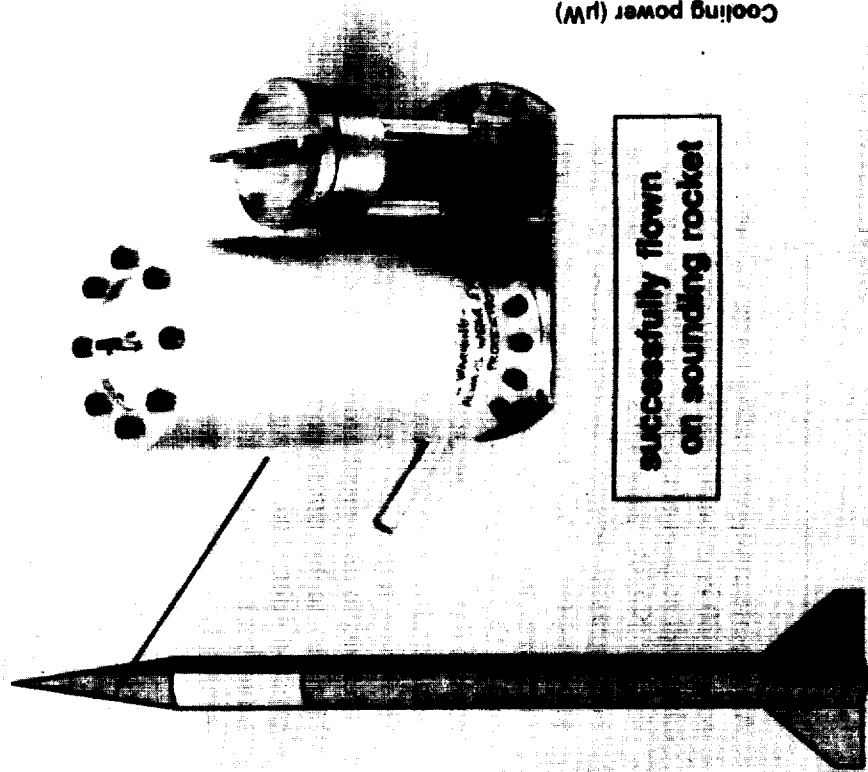

## Advanced Cryogenic Refrigerator for Space

A long-life cryogenic refrigerator capable of cooling detectors to 30 K is being developed by NASA for instruments that will be part of the Earth Observing System (EOS) and future NASA programs in Earth science, astronomy, microgravity science, interplanetary science, and human exploration. NASA needs improved spectral, spatial, and temporal sensitivity to meet its scientific goals. In many cases, these goals can only be met by using cryogenically cooled detectors. Sensitive detectors requiring cryogenic temperatures have been available for more than a decade. However, a long-life, reliable cryogenic refrigerator (often referred to as a mechanical cooler) to cool these detectors has yet to be developed. Only instruments with very limited lifetimes, using massive stored cryogen coolers, have been able to take advantage of the sensitive cryogenically cooled sensors.

The advanced cryogenic refrigerator will build on the single-stage Stirling cycle cooler technology that is presently under development. The goal of the program is to produce a highly reliable cryogenic cooler with a 10-year on-orbit lifetime. The cooler is to be designed for high efficiency, low input power, small size, and low weight. The cooler will also be optimized for low vibration and low electromagnetic interference.

A contract for the development of the advanced cryogenic refrigerator will be released early in 1991, and it is expected that an advanced brassboard cooler will be available by the end of 1993. A number of important tasks were completed during fiscal year 1990 to prepare for the development of the advanced cooler. A testbed has been established at

GSFC to test the most life-limiting aspect of the present Stirling coolers, namely the clearance seals. A second testbed has been completed at the National Institute of Standards and Technology to test regenerative heat exchangers (regenerators). Improved regenerators could greatly improve the efficiency of multistage, low temperature Stirling coolers. Finally, advanced cooler concepts have been successfully pursued. One particularly promising Stirling cooler concept developed over the last 2 years eliminates all clearance seals and regenerators. This novel approach may yield long life with high reliability, low vibration, and unprecedented efficiency.

Technical Contact

Stephen H. Castles, GSFC, (301) 286-5405

# Cryogenic Refrigerator for Space

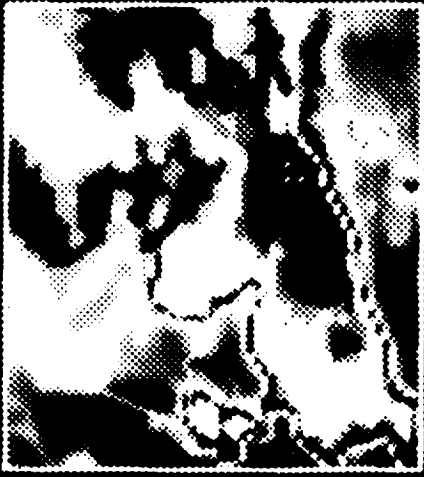
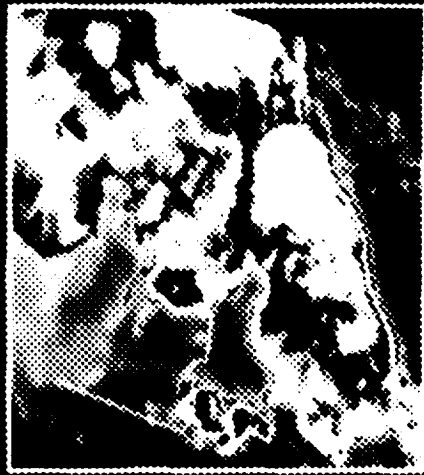
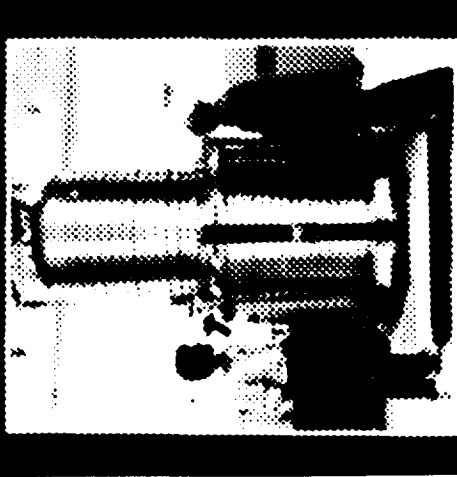
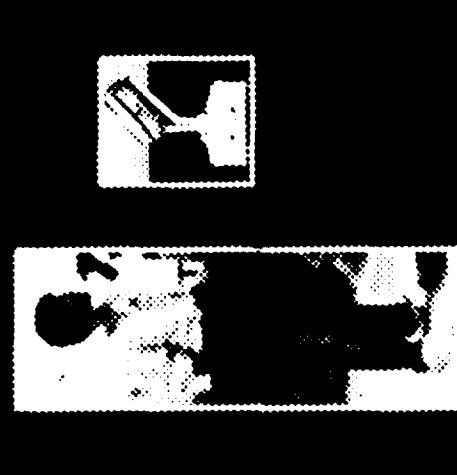
<p>EARTH SCIENCE</p> 	<p>INCREASED ↑ SPECTRAL COVERAGE</p>	<p>EARTH SCIENCE</p> 
<p>1985</p> 	<p>DECREASED SIZE ↑ AND WEIGHT</p>	<p>1985</p> 
<p>1000 KG MASS 0.8 YEAR LIFE</p>		<p>15 KG MASS 5 TO 10 YEAR LIFE</p>

ORIGINAL PAGE IS  
OF POOR QUALITY

ORIGINAL PAGE  
BLACK AND WHITE PHOTOGRAPH

## Advanced Lidar Technology

The focus of this research is in two areas: (1) development of line-narrowed near infrared solid-state laser sources and (2) evaluation of Raman frequency conversion techniques for tunable mid-infrared lasers.

Currently available intracavity line-narrowing technology, such as etalons and Littrow gratings, cannot attain the very narrow linewidths required to obtain atmospheric pressure and temperature measurements using differential absorption lidar (DIAL). GSFC is therefore pursuing advanced semiconductor laser injection seeding (locking) of solid-state alexandrite laser resonators. The approach is to use a low power (10 mW) continuous wave (cw) 760-nm GaAs laser diode beam as a seed source that serves to lock the frequency of the high energy solid-state laser to its own lasing frequency as the solid-state laser comes above threshold. A novel diode laser frequency stabilization scheme is used to ensure that the seed source wavelength is in turn locked and stabilized to the wavelength of the absorption feature being probed.

Nonlinear optical frequency conversion techniques are being investigated at GSFC for the purpose of developing a near continuously tunable laser source from 0.5- to 20- $\mu\text{m}$  wavelength. The technical approach adopted here is to use a commercial, tunable near infrared alexandrite or titanium-doped sapphire laser in conjunction with multiple Stokes shift Raman scattering in gases. In theory, this single, widely tunable laser transmitter could be used to measure meteorological parameters such as pressure, temperature, and water vapor in the near infrared as well as aerosols and pollutants in the mid-infrared. The

current state of the art is such that a variety of lasers are required to probe this region of the optical spectrum.

Proof of principle diode injection seeding of pulsed alexandrite lasers has been recently demonstrated, as has the measurement of oxygen A-band absorption in the newly fabricated optoacoustic cell. These demonstrated technologies were incorporated in a Code SE development program in June of 1990 for further evaluation.

GSFC and Brown University tested the concept of seeding stimulated Raman scattering in gases using a fiber-generated continuum. In the absence of a seed source, the stimulated Raman signal is typically initiated by blackbody or spontaneous emission, and as a consequence, high laser pump powers are required to achieve conversion efficiencies of even a few percent. The seeding experiments were carried out in C methane at 37 atmospheres using 80 psec, 532-nm pump pulses. The methane gas provided an energy shift of the pump beam of  $2,914\text{ cm}^{-1}$ , putting the first Stokes line at 630 nm. The wideband optical radiation continuum generated in a germanosilicate fiber was calculated to have approximately 200 times the energy at 630 nm than spontaneous emission noise. Experiments are currently under way to determine the effectiveness of seeding the Raman process with a fiber continuum to increase the conversion efficiency into the first Stokes order without increasing the pump power.

Technical Contact

Bernard D. Seery, GSFC, (301) 286-8942

# OAET/GSFC Advanced Lidar Technology



Injection Seeded  
Alexandrite Laser



Frequency  
Stabilization Apparatus



Optoacoustic Cell



Sequential Stokes  
Scattering



Stimulated Raman  
Scattering With Fibers

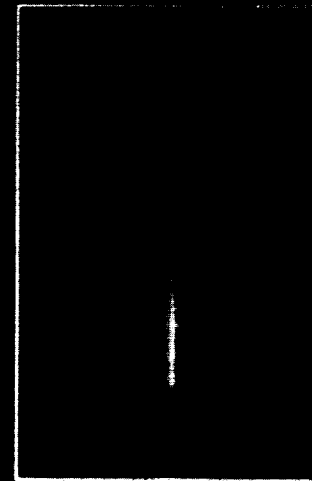

Seeded Raman Spectrum  
from 532 to 850 nm

Variable  
Line-Narrowed  
Near-Infrared  
Laser Sources

Raman Frequency  
Conversion for  
Mid-Infrared Lasers

## Superconducting Magnetic Bearings

The objective of this project is to develop and build an engineering model of a radial passive superconducting magnetic bearing (SCMB) for on-orbit operation of high-speed machinery with the emphasis on mechanical cryocoolers.

Measurements of levitation force, stiffness, and drag have been performed for various superconducting materials. As a result of these tests quench melted Y-Ba-Cu-O ceramic was identified as the best candidate for superconducting magnetic bearings (SCMB) at the present time. It was observed that 5-fold to 6-fold improvement in load capacity can be obtained by decreasing the temperature from 77 K to 4.2 K. Materials fabricated at Catholic University and Japan had the highest magnetization and lift force. For example, the Catholic University sample showed load capacity of 2 psi (14 KPa) at 77 K, which increased to 15 psi (105 KPa) at 4.2 K. A working model of partially enclosed SCMB was built by Cornell University and GSFC and successfully demonstrated at several meetings. A study was performed by Massachusetts Institute of Technology (MIT) that identified several high-payoff applications for SCMB in space. These applications include vibration isolators for cryogenic coolers, oscillating gimbals, cryocoolers, cryoturbopumps, cryoalternators, cryofluid circulators, and space turbines. These applications are of interest to NASA, SDIO, DARPA, DOE, and other agencies. Consequently, a draft Interagency SCMB Development Program has been prepared by GSFC and MSFC and distributed to the agencies for comments.

Recently a contract was prepared for Cornell University to

perform engineering characterization of passive SCMB. Comments from agencies interested in a joint SCMB program will be incorporated in the final draft, which will be presented to NASA Headquarters. An effort is under way to map the magnetic field within the magnet/superconduct gap, and a set-up is under design to measure the magnetic stiffness of the magnetic disc levitated inside a superconducting cylinder. The SCMB model should be operational in FY 1990.

Technical Contact

Yury Flom, GSFC, (301) 286-3274



# Superconducting Magnetic Bearings

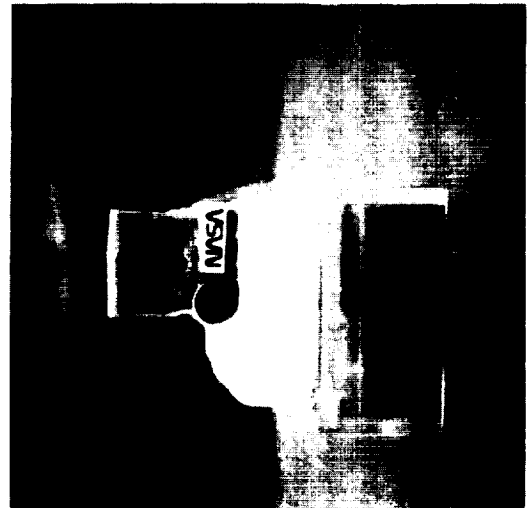
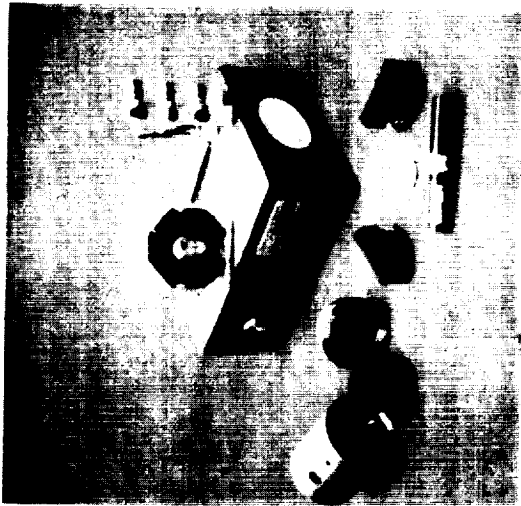

COMPONENTS OF SCMB MODELS  
WORKING MODEL OF  
PARTIALLY INCLOSED SCMB

LEVITATION OF MAGNET INSIDE  
SUPERCONDUCTING CYLINDER

## Diode-Pumped Neodymium Lasers

Conventional neodymium (Nd) lasers are pumped by broadband flashlamp technology, which is inherently inefficient, unreliable, and bulky. Laser-diode-pumped Nd technology, on the other hand, promises high efficiency, long-autonomous operation, and compact packaging. These characteristics are well suited for airborne and space-based remote sensing applications. However, before diode-pumped Nd lasers can be designed for these applications, many physics and engineering questions need to be answered. Physical parameters of Nd laser materials such as emission and absorption cross-sections, excited-state absorption, and self-absorption need to be quantified in order to predict laser system performance for remote sensing applications.

YAG, YLF, BEL, Phosphate Glass, and Vanadate are some of the more promising host materials for Nd lasers being investigated for remote sensing applications. Although the strongest laser transition for all of these materials is nominally at 1.06  $\mu\text{m}$ , other important parameters are significantly different. Comparison of the performance of these materials then requires a good understanding of the physical parameters of the materials so that conditions for lasing can be individually optimized for each. For example, the well-known material, Nd:YAG, has a strong absorption peak at 0.808  $\mu\text{m}$  and a upper-state lifetime of 240  $\mu\text{s}$ . A lesser known material, Nd:YLF, has a strong absorption peak at 0.792  $\mu\text{m}$  and lifetime of 480  $\mu\text{s}$ . From this information, it is immediately evident that optimization of the performance of these materials will require pumping each with diodes operating at different wavelengths and with different pulsewidths.

Laser-diode-pumped Nd lasers will provide reliable, efficient, and compact sources of 1.06- $\mu\text{m}$  photons in the fundamental, and photons in the second and third-harmonics of the fundamental, at 0.53  $\mu\text{m}$ , respectively. The Nd lasers and the harmonics will provide the source for measuring aerosols directly. In addition, the second harmonic of Nd lasers can be used to pump Ti:Al<sub>2</sub>O<sub>3</sub> lasers. Using the latter laser, water vapor as well as pressure and temperature can be measured.

Parameters such as absorption, lifetime, and excited state absorption (ESA) have been measured for the majority of the Nd materials. YLF and YAG exhibited ESA, which can be a detriment to system efficiency. An effort to quantify the extent of the ESA as a function of pump is under way. This will add significantly to capabilities of scaling these two materials for high-power outputs. Resonator and coupling designs have been implemented and major components have been ordered or are being fabricated. Laser diode arrays (wavelength matched for pumping YAG, YVO<sub>4</sub>, and BEL) have been delivered and are in the process of being characterized.

Technical Contact

James C. Barnes, LaRC, (804) 864-1637

# Diode-Pumped Neodymium Technology

ONE OF THREE SDL 25W ARRAYS USED TO PUMP Nd LASERS



DIODE ARRAY PUMPED Nd LASER APPARATUS IN DEVELOPMENT

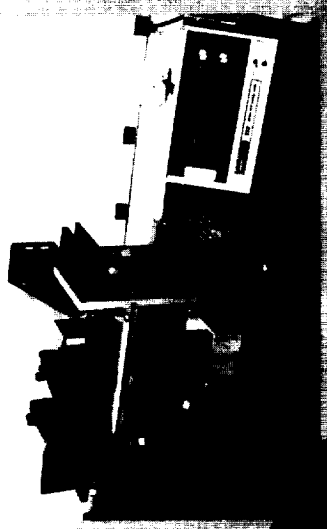

**DIODE  
ARRAY  
PUMPED  
Nd  
TECHNOLOGY**

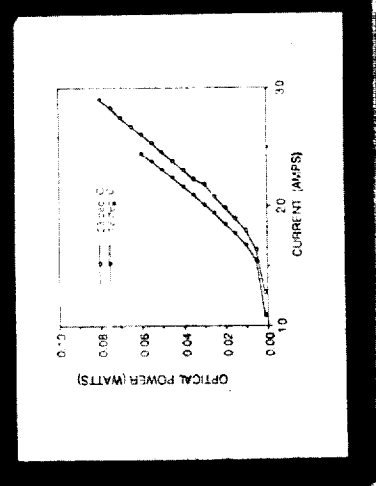

DIODE ARRAY POWER AS A FUNCTION OF CURRENT

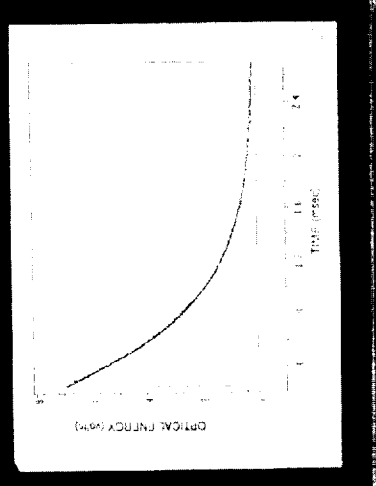

Nd:YLF FLUORESCENCE LIFETIME OF  $>400 \mu\text{s}$  CONDUCTIVE FOR DIODE ARRAY PUMPING

ORIGINAL PAGE  
BLACK AND WHITE PHOTOGRAPH

## HgZnTe Materials and Device Technology

There is a critical national need for infrared (IR) detector technology to meet NASA mission requirements for the 1990s and beyond. The EOS instruments require photo-voltaic (PV) IR detectors in large linear and area array formats having unprecedented sensitivity and resolution covering the mid-IR (3-5  $\mu\text{m}$ ) and the far-IR (8-20  $\mu\text{m}$ ). These detectors will be expected to operate unattended for periods of 5 or more years. Present IR detector technology is based on HgCdTe devices that are difficult to process in array formats, unstable in their electro-optical properties, suffer from poor reliability, and have not demonstrated PV technology beyond 13  $\mu\text{m}$ . The objective of this program is to develop advanced IR materials and devices in HgZnTe having improved robustness and reliability for remote sensing applications from satellite platforms.

HgZnTe materials for the mid-IR and far-IR have been developed, and 270 x 1 linear arrays have been fabricated. Initial measurements on the 270 x 1 arrays at 80 K and 30 K have yielded outstanding results; the spectral response has been extended to beyond 20  $\mu\text{m}$ ,  $D^*$  sensitivities are greater than  $1 \times 10^{10}$ , and the responsivities are greater than  $1 \times 10^4$ . French investigators (Triboulet at SAT) have reported HgZnTe single devices to 15  $\mu\text{m}$  that are bakable (can be mounted in long-life dewars), and SAT is now offering HgZnTe IR single devices as part of their standard IR product line.

Near-term plans are to complete characterization of the current linear array, deliver an array to JPL and LaRC for additional testing, and initiate development of far-IR HgZnTe diodes. The technology being developed on this

program has direct application to several of the planned EOS missions, AIRS, MODIS-N, and SAFIRE.

Technical Contact

William E. Miller, LaRC, (804) 864-1720

# HgZnTe Solves NASA Requirements for Reliable Longwave IR Detectors

HgZnTe Materials development

**Materials growth**  
HgZnTe 1988 accomplishment

100 μm

1988 Device quality substrates

HgZnTe vacuum bake results

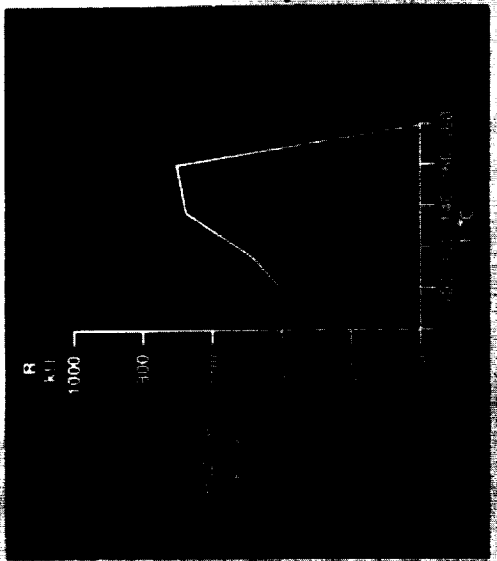

1990 Enhanced bake stability

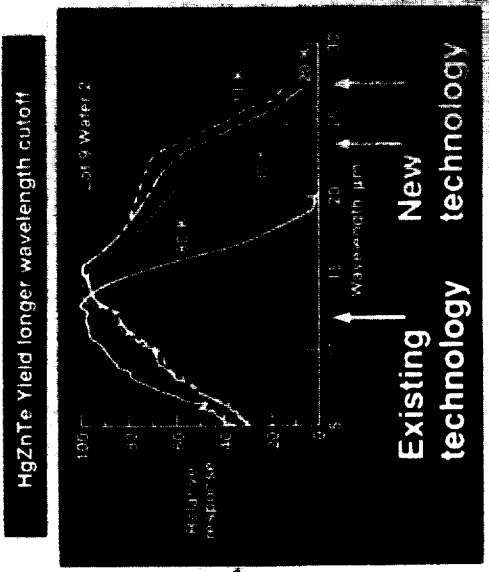

1989 Device quality epi layers

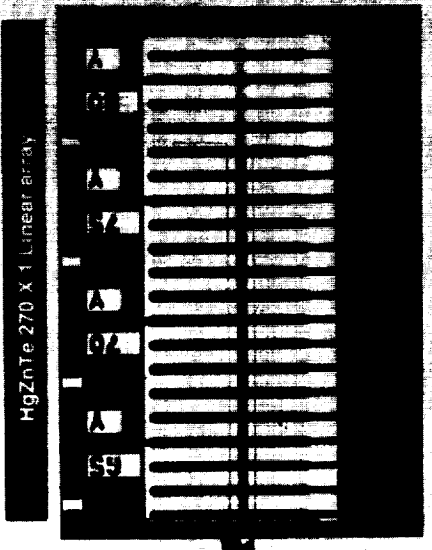

1990 Longwave (>20μm) arrays demonstrated

ORIGINAL PAGE  
BLACK AND WHITE PHOTOGRAPH

## High-Temperature Superconductivity Material Applied to Devices for Aerospace Technology

The high thermal conductivity ceramic superconductor LaRC-sponsored effort presently focused on developing and demonstrating the feasibility of fabricating composite linear bearings using the Meissner effect (shown in figure) and rigidly supported, environmentally protected superconducting circuit elements such as conductors, coils, connectors, and crossovers on dielectric substrates for microelectronic applications with emphasis on a specific application for the NASA-SAFIRE program (i.e., a low-noise, low thermal conductivity, superconducting grounding strap for a highly sensitive, far-infrared, atmospheric detector [see figure]). Based on the theory that these superconducting ceramics are brittle by nature, the devices should be fabricated on pre-formed, sintered, and tested material bonded to a rigid substrate such as in a hybrid circuit. This concept has the advantages of (1) pretesting the superconducting material separate from the substrate, (2) optimization of the superconducting properties of the material without limitations imposed by the substrate, (3) wider selection of substrate materials, since the high temperature processing step precedes mounting onto the printing circuit board, (4) freedom from firing shrinkage and other numerous material compatibility problems, and (5) anticipated high reliability because of its rigid design and encapsulation from the environment.

A collaborative and interactive testing program between personnel at Clemson University and Westinghouse Savannah River Company is directed toward obtaining first-time field test data on the superconducting ground strap described above. The program is designed to provide preliminary real-time data on the suitability of using the

123 superconducting material and devices made from it in a space environment, and to point out at an early stage any deficiencies that may result from the tests. The deficiencies, if any, will be corrected and retested wherever possible.

The specific tests of primary concern are designed to critically evaluate the various materials (e.g., 123 ceramic, epoxy encapsulants, substrates, and connectors), and devices made from them in an environment that simulates, as closely as possible, the actual conditions in space. Accordingly, these include (1) long-term stability in a high vacuum, (2) radiation damage due to high-energy gamma rays, (3) degradation of properties as a result of thermal cycling and thermal shock, (4) mechanical stability due to vibration, (5) moisture sensitivity, and (6) loss of superconductivity due to exposure to magnetic fields (see figure).

In addition to the superconductor device produced at Clemson University, the Christopher Newport College Physics Department has developed and is optimizing a low-electric resistant joint material ( $10^{-6} \Omega$ ) for use in connecting the ceramic superconductor into the circuit. Successful tests have been performed on typical specimens for thermal shock, moisture sensitivity, and mechanical strength (see figure).

Technical Contact

John D. Buckley, LaRC, (804) 864-4557

# High-Temperature Superconductivity Materials Applied to Devices for Aerospace Technology



SPACE ENVIRONMENT COMPATIBILITY  
TEST OF GENERIC CIRCUIT ELEMENTS

Circuit Elements      Simultaneous Space Conditions

Superconducting Devices and Circuit Elements for Space Applications

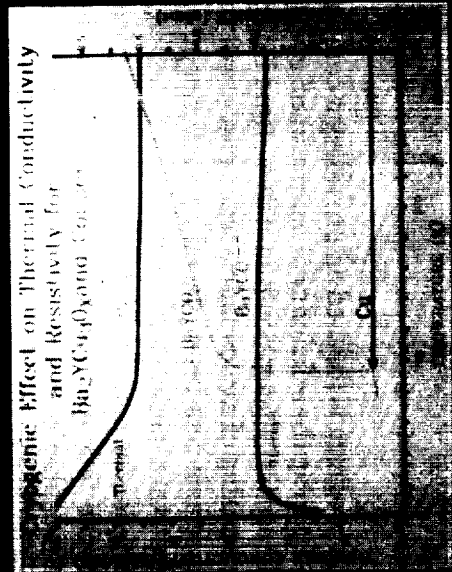
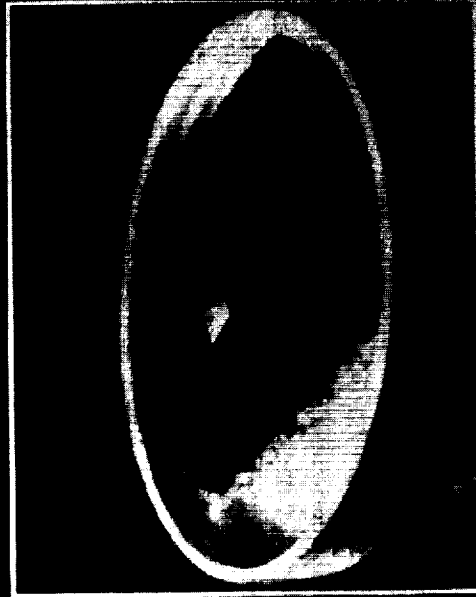

## Modeling of Multiply Doped Eye-Safe Solid-State Lasers for DIAL and Doppler Lidar

This research program is focused on providing a computer model for optimizing the efficiency of narrowband eye-safe lasers for differential absorption lidar (DIAL) and Doppler lidar remote sensing of atmospheric trace gases and wind velocity. Emphasis has been placed on multidoped rare earth ion solid-state lasers that operate near  $2\ \mu\text{m}$ , which offer the potential for both high efficiency frequency conversion into the  $2\text{-}5\ \mu\text{m}$  vibration-rotational bands of several key atmospheric constituents or can be used directly for wind velocity/shear sensing.

Laser performance depends critically on many variables, which include mirror reflectivities, cavity losses, type and concentration of lasing and co-dopant ions, and laser pump intensity. To vary these parameters in the laboratory would be difficult, time consuming, and cost prohibitive. By exercising a validated computer model, a detailed understanding of the physical interaction mechanisms can be gained and predictions can be made to enable the researcher to accurately judge which of the variables to more closely examine in the laboratory.

The detailed rate equation model previously developed to describe energy transfer and laser activity for multiple ion-doped rare earth lasers has been upgraded to include several new up-conversion interactions. This model has been applied to describe laser performance of a room temperature thulium and holmium codoped yttrium aluminum garnet (Tm:Ho:YAG) laser pumped with a chromium doped gadolinium scandium aluminum garnet (Cr:GSAG) laser-simulating diode laser pumping. The rate constants necessary to characterize the Tm-to-Tm

and Tm-to-Ho energy transfer processes, as well as the additional up-conversion interactions, have been obtained from NASA-LaRC spectroscopic measurements. The model has been validated by comparing with experimental results for a variety of rod lengths, pump intensities, output couplers, and dopant concentrations.

Technical Contact

Clayton H. Bair, LaRC, (804) 864-1556



# Model Development for 2-Micrometer Eye-Safe Lidar

## IMPROVED PERFORMANCE LASER DESIGN

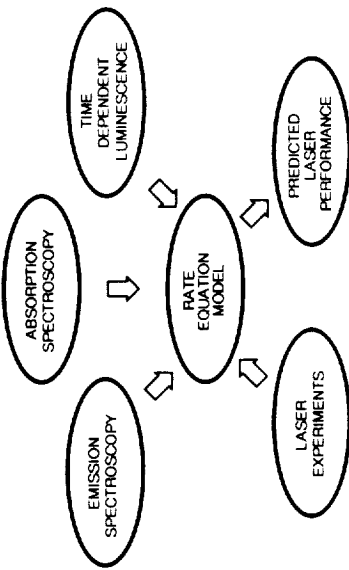

## RATE EQUATION MODEL SUMMARY

- 13 COUPLED, NON-LINEAR, DIFFERENTIAL EQUATIONS
- ION POPULATION EQUATIONS (6  $T_m$ , 4  $H_o$ )
- PHOTON EQUATIONS (3 LASER WAVELENGTHS)
- TERMS INCLUDED: LINEAR FLUORESCENCE

BI-LINEAR ENERGY TRANSFER

PHOTON-ION INTERACTION

THERMAL OCCUPATION FACTORS

COMPARISON OF MEASURED AND CALCULATED DECAY OF THE  $T_m$  PUMP LEVEL IN CO-DOPED YAG

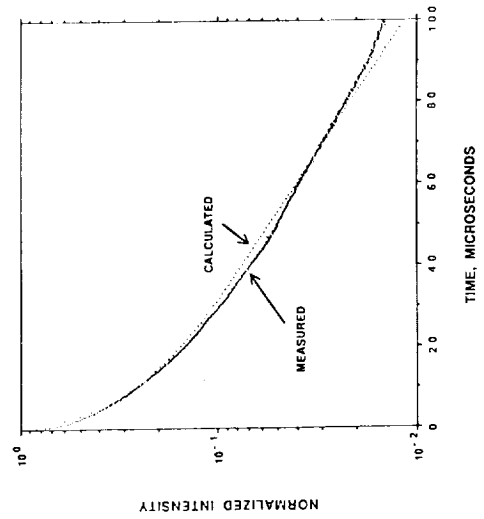

PHOTON DENSITY AS A FUNCTION OF TIME FOR ROOM TEMPERATURE  $Tm:Ho:YAG$  LASER

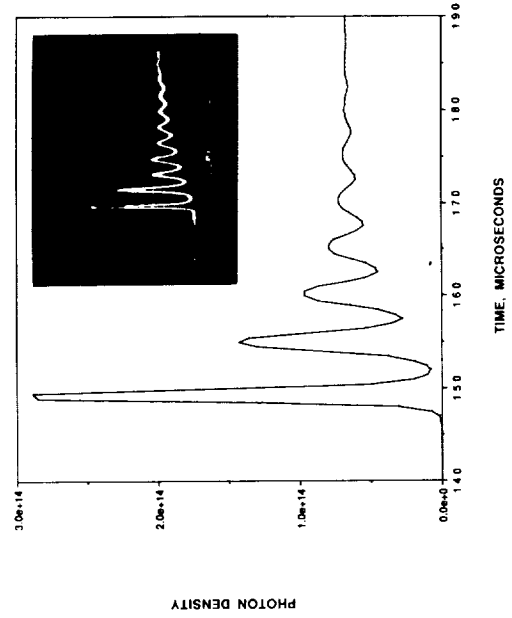

## Titanium: Sapphire Development for LIDAR

Ti:Al<sub>2</sub>O<sub>3</sub> is an efficient, high-gain, tunable laser source that spans the spectral region from 0.65 μm to 1.1 μm. Unlike alexandrite, another tunable source, Ti:Al<sub>2</sub>O<sub>3</sub> has a large effective emission cross-section. Consequently, it can operate efficiently and reliably at low-energy densities. With the advent of diode-pumped Nd lasers, this material can be laser-pumped efficiently and reliably. The overall system efficiency of a diode-pumped, frequency-doubled Nd laser pumping Ti:Al<sub>2</sub>O<sub>3</sub> is in excess of 5%.

Ti:Al<sub>2</sub>O<sub>3</sub> provides a frequency-agile solid-state laser source in the 0.65 μm to 1.1 μm region for Lidar and DIAL experiments. The laser accesses weak H<sub>2</sub>O absorption bands around 0.73 μm and the stronger absorption bands around 0.94 μm. This wide spectral coverage allows accurate water vapor measurements for a wide dynamic range of water vapor concentrations. Pressure and temperature can be measured using oxygen bands around 0.76 μm. These bands are also accessible with Ti:Al<sub>2</sub>O<sub>3</sub>. Thus, a single-Lidar instrument would perform three important DIAL measurements. Recent frequency doubling of Ti:Al<sub>2</sub>O<sub>3</sub> by contractors at LaRC with better than 50% conversion lends promise to tripling capabilities to the ultraviolet. This would allow a Ti:Al<sub>2</sub>O<sub>3</sub> system to address NO and OH radicals as well.

Water vapor and pressure/temperature measurements continue to surface as prime scientific parameters in the atmospheric sciences and meteorological community. Knowledge of global water vapor distribution is required for studying climate, the hydrological cycle, and meteorological processes, and temperature distribution provides invaluable science on tropopause heights and meteorological conditions. In addition, such sources are valuable

research tools in the spectral region where dye laser performance is limited.

A Ti:Al<sub>2</sub>O<sub>3</sub> power oscillator, operating at 10 Hz, and with subpicometer linewidths has demonstrated 430 mJ pulsed energy output at LaRC under a NASA LaRC funded contract. This output was demonstrated at the important wavelengths around 0.73 μm and 0.76 μm with better than 35% optical-to-optical efficiency. The subpicometer linewidths were accomplished by seeding the power oscillator with a cw-ring single-mode oscillator also developed under the contract. The cw-oscillator has led to a commercial device, and a version of the power oscillator is being developed by the contractor and will be available this summer. The 430 mJ Ti:Al<sub>2</sub>O<sub>3</sub> laser has been accepted for delivery at LaRC, and is presently being characterized.

The Ti:Al<sub>2</sub>O<sub>3</sub> laser system is being proposed to replace alexandrite as the laser transmitter for NASA's Lidar Atmospheric Sensing Experiment (LASE) mission to measure H<sub>2</sub>O vapor profile. In a series of independent experiments, the Ti:Al<sub>2</sub>O<sub>3</sub> laser met all of the LASE requirements. LaRC is currently performing engineering of the laser to simultaneously meet the LASE transmitter requirements.

Technical Contact

James C. Barnes, LaRC, (804) 864-1637

# Titanium: Sapphire Laser Products

THE SCHWARTZ ELECTRO-OPTICS TITAN CW-RING LASER WAS RECOGNIZED AS A TOP TEN NEW PRODUCT

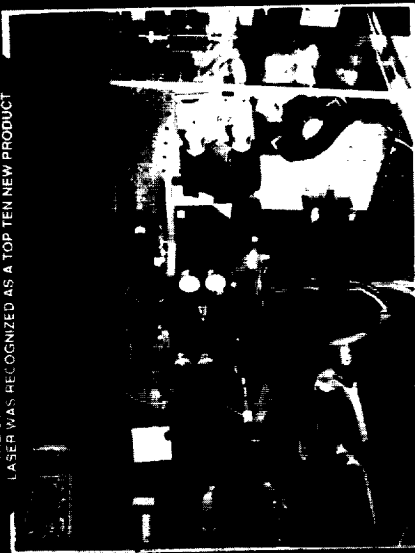

THE SEO POWER OSCILLATOR WAS OFFERED AS A PRODUCT AT THE 1980 CLEO CONFERENCE

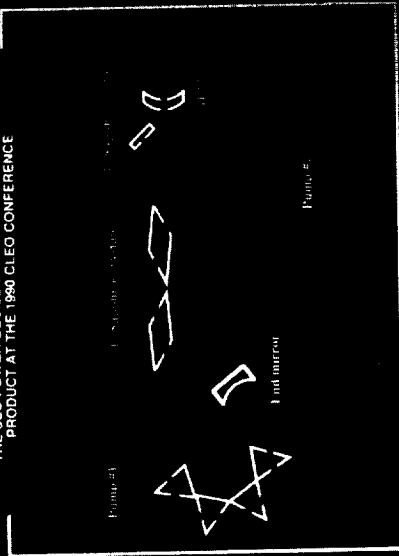

## TITANIUM SAPPHIRE LASER PRODUCTS DEVELOPED UNDER NASA RTOP

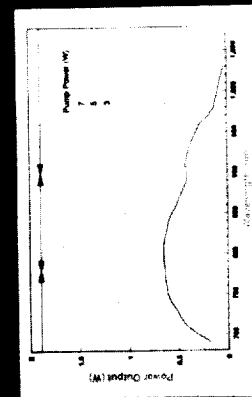

FORMING GUIDES FOR TITAN CW STANDING-WAVE RING CAVITY

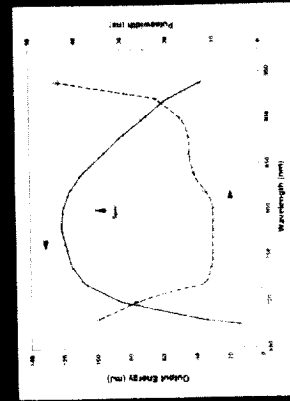

LASER PERFORMANCE OF TITAN PULSED TITANIUM SAPPHIRE LASER





# Report Documentation Page

1. Report No. NASA TM-4291		2. Government Accession No.		3. Recipient's Catalog No.	
4. Title and Subtitle NASA Information Sciences and Human Factors Program--Annual Report, 1990			5. Report Date May 1991		
			6. Performing Organization Code RC		
7. Author(s) Lee Holcomb, Ray Hood, Melvin Montemerlo, James Jenkins, Paul Smith, John DiBattista, Ramon De Paula, Paul Hunter, and David Lavery			8. Performing Organization Report No.		
			10. Work Unit No.		
9. Performing Organization Name and Address NASA Office of Aeronautics, Exploration and Technology Information Sciences and Human Factors Division			11. Contract or Grant No.		
			13. Type of Report and Period Covered Technical Memorandum		
12. Sponsoring Agency Name and Address National Aeronautics and Space Administration Washington. DC 20546			14. Sponsoring Agency Code		
			15. Supplementary Notes		
16. Abstract <p>This report contains fiscal year 1990 descriptions of technical accomplishments in seven sections: Automation and Robotics, Communications, Computer Sciences, Controls and Guidance, Data Systems, Human Factors, and Sensor Technology.</p>					
17. Key Words (Suggested by Author(s)) Controls Guidance Navigation Automation Robotics Human Factors Computer Science Data Systems Sensors Communications			18. Distribution Statement Unclassified--Unlimited  Subject Category 99		
19. Security Classif. (of this report) Unclassified		20. Security Classif. (of this page) Unclassified		21. No. of pages 221	22. Price A10



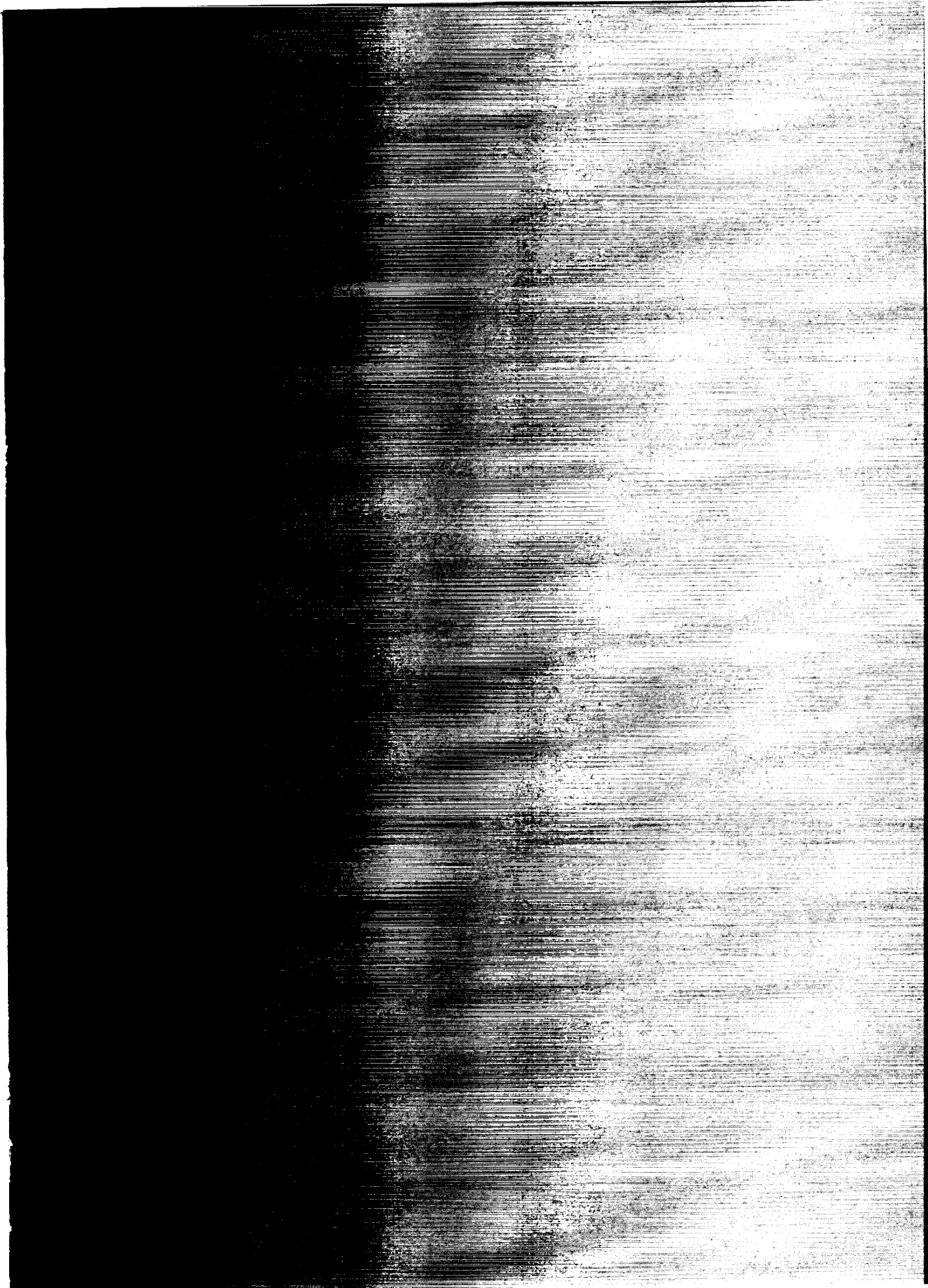

National Aeronautics and  
Space Administration  
Code NTT

Washington, D.C.  
20546-0001

Official Business  
Penalty for Private Use, \$300

**NASA**

National Aeronautics and  
Space Administration

Washington, D.C.  
20546

**SPECIAL FOURTH CLASS MAIL  
BOOK**

Postage and Fees Paid  
National Aeronautics and  
Space Administration  
NASA-451

Official Business  
Penalty for Private Use \$300



L2 001 TH-4291 9105308990569A

NASA  
CENTER FOR AEROSPACE INFORMATION  
ACCESSIONING DEPT  
P O BOX 8757 BWI ARPT  
BALTIMORE MD 21246

**NASA**