

8-21-71
E 6353

NASA
Technical Memorandum 104496

AVSCOM
Technical Report 91-C-034

Surface Fatigue Life of M50NiL and AISI 9310 Spur Gears and R C Bars

Dennis P. Townsend
*Lewis Research Center
Cleveland, Ohio*

and

Eric N. Bamberger
*General Electric Company
Cincinnati, Ohio*

Prepared for the
International Conference on Motion and Power Transmissions
sponsored by the Japan Society of Mechanical Engineers with the participation of
ASME, I. Mech. E., VDI, I.E.T., CSME and other societies
Hiroshima, Japan, November 24-26, 1991

NASA



SURFACE FATIGUE LIFE OF M50NiL AND AISI 9310 SPUR GEARS AND RC BARS

Dennis P. Townsend
National Aeronautics and Space Administration
Lewis Research Center
Cleveland, Ohio

and

Eric N. Bamberger
General Electric Company
Cincinnati, Ohio

ABSTRACT

Spur gear endurance tests and rolling-element surface fatigue tests were conducted to investigate vacuum-induction-melted, vacuum-arc-remelted (VIM-VAR) M50NiL steel for use as a gear steel in advanced aircraft applications, to determine its endurance characteristics, and to compare the results with those for standard VAR and VIM-VAR AISI 9310 gear material. Tests were conducted with spur gears and rolling-contact bars manufactured from VIM-VAR M50NiL and VAR and VIM-VAR AISI 9310. The gear pitch diameter was 8.9 cm (3.5 in.). Gear test conditions were an inlet oil temperature of 320 K (116 °F), an outlet oil temperature of 350 K (170 °F), a maximum Hertz stress of 1.71 GPa (248 ksi), and a speed of 10 000 rpm. Bench rolling-element fatigue tests were conducted at ambient temperatures with a bar speed of 12 500 rpm and a maximum Hertz stress of 4.83 GPa (700 ksi). The VIM-VAR M50NiL gears had a surface fatigue life that was 4.5 and 11.5 times that for VIM-VAR and VAR AISI 9310 gears, respectively. The surface fatigue life of the VIM-VAR M50NiL rolling-contact bars was 13.2 and 21.6 times that for the VIM-VAR and VAR AISI 9310, respectively. The VIM-VAR M50NiL material was shown to have good resistance to fracture through a fatigue spall and to have fatigue life far superior to that of both VIM-VAR and VAR AISI 9310 gears and rolling-contact bars.

INTRODUCTION

Recent developments by aircraft turbine engine groups and others have required the use of fracture-resistant bearing materials for integral rolling-element bearing races. Higher speed bearings require races with good fracture toughness to prevent serious failures after a race fatigue failure (i.e., spall) occurs. The use of advanced high-hot-hardness steels for aircraft engine bearings and aircraft transmissions for helicopters, VSTOL, and geared fans or turboprops has been shown^{1,2} to extend the operating life at higher operating temperatures. In addition the use of high-hot-hardness materials can considerably lengthen operating times if the lubrication and cooling system fails and the operating temperature increases.

Several high-hot-hardness carburizing grade gear steels have been developed in recent years, and tests with these materials have shown longer

surface fatigue lives than standard AISI 9310 gear steel.³⁻⁵ A more recent high-hot-hardness steel, M50NiL, was developed originally as a carburizing-grade race material for rolling-element bearings. It improved fracture toughness while retaining hot hardness and long bearing fatigue life.⁶ This material was developed from the standard AISI M50 bearing material by reducing the carbon content to improve the fracture toughness and by adding a small amount of nickel to stabilize the austenite and to prevent the formation of excessive amounts of ferrite and retained austenite.⁶ With its reduced carbon content the M50NiL material can be case carburized to give a hard bearing surface while retaining a tough core. Rolling-contact (RC) fatigue tests with M50NiL⁶ have shown it to have excellent surface fatigue life.

The objectives of the research reported herein were (1) to investigate M50NiL for use as a gear material, (2) to determine the surface endurance characteristics of M50NiL, and (3) to compare the results with those for standard VAR and VIM-VAR AISI 9310 aircraft gear materials. To accomplish these objectives, tests were conducted with spur gears and RC test bars manufactured from M50NiL. For comparison purposes spur gears and RC test bars manufactured from VAR and VIM-VAR AISI 9310 were also tested for fatigue life. The gear pitch diameter was 8.9 cm (3.5 in.). Test conditions for the gears included an inlet oil temperature of 320 K (116 °F) that resulted in an outlet oil temperature of 350 K (170 °F), a maximum Hertz stress of 1.71 GPa (248 ksi), and a speed of 10 000 rpm. The rolling-element fatigue tests^{6,7} were conducted with 0.952-cm (0.375-in.) diameter test bars. The RC tests were conducted at ambient temperature with a bar speed of 12 500 rpm and a maximum Hertz stress of 4.83 GPa (700 ksi).

APPARATUS AND PROCEDURES

Gear Test Apparatus

The gear fatigue tests were performed in the NASA Lewis Research Center's gear fatigue test apparatus (Fig. 1). This test rig uses the four-square principle of applying the test gear load so that the input drive only needs to overcome the frictional losses in the system. Oil pressure and leakage flow are supplied to the load vanes through a shaft seal. As the oil pressure on the load vanes inside the slave gear is increased, torque is applied to the shaft. This torque is transmitted

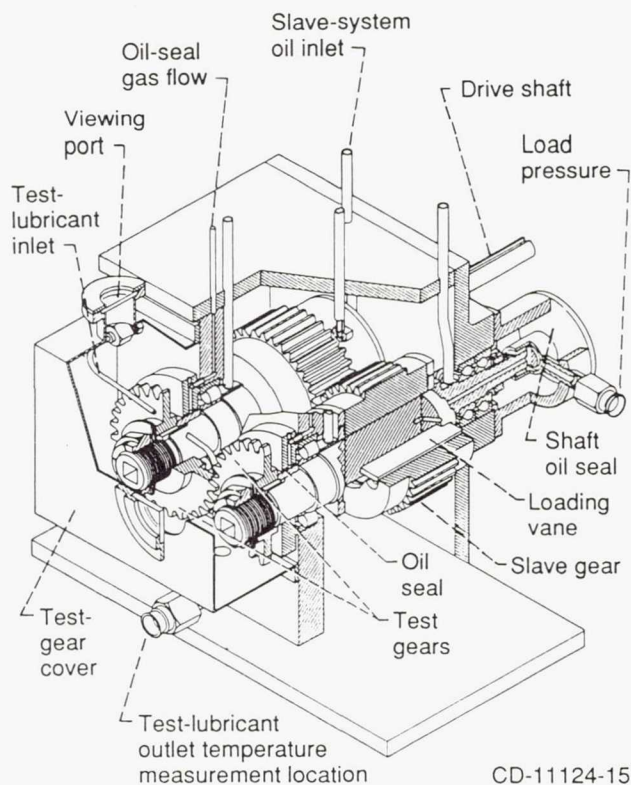

CD-11124-15

Figure 1.—NASA Lewis Research Center's gear fatigue test apparatus.

through the test gears back to the slave gear, where an equal but opposite torque is maintained by the oil pressure.

Separate lubrication systems are provided for the test gears and the main gearbox. The two lubrication systems are separated at the gearbox shafts by pressurized labyrinth seals. Nitrogen is the seal gas. The test gear lubricant is filtered through a 5- μ m nominal fiberglass filter.

The belt-driven test rig can be operated at several fixed speeds by changing pulleys. The operating speed for the tests reported herein was 10 000 rpm.

Rolling-Contact Fatigue Tester

A cylindrical test bar is mounted in the precision chuck. The drive motor attached to the chuck drives the bar, which in turn drives two idler rollers. Load is applied by closing the rollers against the test bar with a micrometer-threaded turnbuckle and a calibrated load cell. Lubrication is supplied by a drop feed system. The test bar rotates at 12 500 rpm and receives 25 000 stress cycles per minute. The maximum Hertz stress was 4.83 GPa (700 ksi).

Test Gears and RC Bar Specimens

The dimensions of the gears are given in Table I. The test specimens for the RC fatigue tester were cylindrical bars 7.6 cm long with a 0.952-cm diameter. The surface finish was 0.13 to 0.20 μ m.

The large mating rollers had a diameter of 19 cm and a crown radius of 0.635 cm. The surface finish of the rollers was the same as that of the test bars.

TABLE I. - GEAR DATA
[Gear tolerance per AGMA class 12.]

Number of teeth	28
Module	3.2
Pressure angle, deg	20
Pitch diameter, cm	8.890
Tip relief, cm	0.0013
Tooth width, cm	0.64
Surface finish, Nm	0.41

Test Material

The 9310 test gears and RC bars were manufactured from either vacuum-arc-remelted (VAR), consumable-electrode vacuum-melted (CVM), or vacuum-induction-melted, vacuum-arc-remelted (VIM-VAR) AISI 9310.

The M50NiL test gears and RC bars were manufactured from VIM-VAR material. This M50NiL material was developed from a standard AISI M50 by reducing the carbon content from 0.85 to 0.13 to provide improved fracture toughness and adding a small amount of nickel (3.4 percent) to stabilize the austenite and to prevent the formation of excessive amounts of ferrite and retained austenite.

The chemical composition of the test gears and RC bars is given in Table II. The heat treatment procedure for the gears and RC bars is given in Table III. The gears and RC bars were case carburized and hardened to case hardness of RC 60. The case and core photomicrographs of the 9310 and M50NiL are shown in Figs. 2(a) and (b), respectively. The retained austenite for the M50NiL is much higher than would be expected for the treatment procedure specified in Table III. This high level of retained austenite was apparently the result of missing the deep freeze treatment. It was not expected that the absence of the deep freeze would significantly change the fatigue life of the M50NiL gears.

Lubricant

All the gears were lubricated with a single batch of synthetic paraffinic oil, which was the standard test lubricant for the gear tests. The

TABLE II. - CHEMICAL COMPOSITION
OF TEST MATERIALS,
wt %

Element	AISI 9310	M50NiL
Carbon:		
Core	0.11	0.13
Case	.81	.86
Manganese	.58	.28
Phosphorus	.003	.002
Sulfur	.004	.002
Silicon	.26	.18
Copper	.21	.05
Chromium	1.38	4.21
Molybdenum	.13	4.30
Vanadium	-----	1.19
Nickel	3.20	3.44
Cobalt	-----	.01
Iron	Balance	Balance

physical properties of this lubricant are summarized in Table IV. Five vol % of an extreme-pressure additive designated Lubrizol 5002 (partial chemical analysis given in Table IV) was added to the lubricant.

The RC test specimens were lubricated with a standard diester test lubricant that met the

MIL-L-7808G specification. The fluid was a mixture of two base stocks, a diester plus a (trimethylol propane) polyester. The additives in this fluid included antioxidants, load-carrying additives, metal passivators, a hydrolytic stability additive, and a silicone antifoam additive. The types and levels of the additives are proprietary.

Test Procedure

Gears. After the test gears were cleaned to remove their protective coating, they were assembled on the test rig. The test gears ran in an offset condition with a 0.30-cm tooth-surface overlap to give a load surface on the gear face of 0.28 cm, allowing for an edge radius on the gear teeth.

If both faces of the gears were tested, four fatigue tests could be run for each set of gears. All tests were run-in at a load per unit length of 1230 N/cm for 1 hr. The load was then increased to 5800 N/cm, which resulted in a pitchline maximum Hertz stress of 1.71 GPa. At the pitchline load the tooth bending stress was 0.21 GPa if plain bending was assumed. Combining the bending and torsional moments due to the offset load, gave a maximum stress of 0.26 GPa.

Operating the test gears at 10 000 rpm gave a pitchline velocity of 46.55 m/sec. Lubricant was supplied to the inlet mesh at 800 cm³/min and 320±6 K. The lubricant outlet temperature was nearly constant at 350±3 K. The tests ran continuously until the rig was automatically shut down by the vibration detection transducer (located on the gearbox adjacent to the test gears) or until 500 hr of operation without failure were completed. The lubricant circulated through a 5-μm fiberglass filter to remove wear particles. For each test 3.8 liters of lubricant were used. At the end of each test, the lubricant and the filter element were discarded.

The pitchline elastohydrodynamic (EHD) film thickness was calculated by the method of Dowson.⁸ Assuming the contact temperature was equal to the outlet oil temperature. The EHD film thickness for these conditions was computed to be 0.33 μm, which gave an initial ratio of film thickness to composite surface roughness h/σ of 0.55 at the 1.71-GPa pitchline maximum Hertz stress.

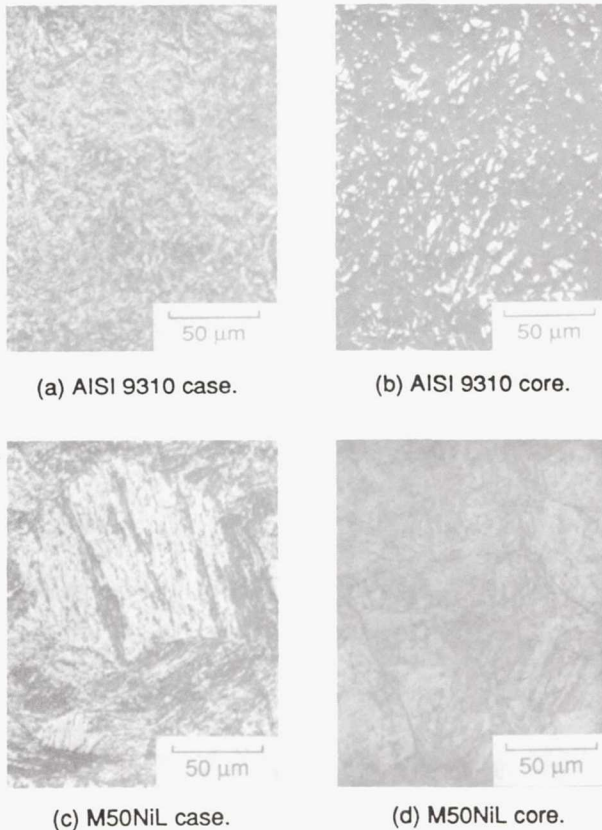

Figure 2.—Case and core microphotographs of AISI 9310 and M50NiL test samples.

TABLE III. — HEAT TREATMENT PROCEDURE FOR MATERIALS TESTED

Step	Process	AISI 9310		M50NiL	
		Temperature, °F	Time, hr	Temperature, °F	Time, hr
1	Preoxidation	----	----	1750	a ₂
2	Carburizing	1650	8	1750	b ₁₂
3	Tempering	1200	10	1200	c ₂
4	Preheating	----	----	1500	-----
5	Austenizing or hardening	1500	2.5	2025	.25
6	Quenching	----	----	1100	.2
7	Tempering	----	----	975	2
8	Deep freezing	-120	----	-100	d ₁
9	Tempering	350	2	975	2 + 2

^aAir.

^bAt 0.7 CP.

^cOil quench.

^dOmitted by error on gears.

TABLE IV. — LUBRICANT PROPERTIES

Property	Synthetic paraffinic oil plus additives ^a
Kinematic viscosity, cm ² /sec at	
100 °F	31.6x10 ⁻²
210 °F	5.5x10 ⁻²
Fire point, °F	500
Pour point, °F	65
Specific gravity	0.8285
Specific heat at 100 °F J/kg K	2190

^aEP additives: Lubrizol 5002 (5 vol %) containing 0.03 vol % phosphorus and 0.93 vol % sulfur.

Each running surface on a pair of gears was considered as a system and, hence, a single test. Test results were evaluated by using Weibull plots calculated by the method of Johnson.⁹ (A Weibull plot is the number of stress cycles versus the statistical percentage of gear systems failed.) Since the gears were run in an offset condition, four tests were obtained from each pair of gears.

RC tests. Fatigue testing was also performed in the RC rig. The test bar was installed and the rollers were brought against the bar by using the turnbuckle. The load applied was sufficient to allow the bar to drive the contacting rollers and the bar was accelerated to the 12 500-rpm test speed.

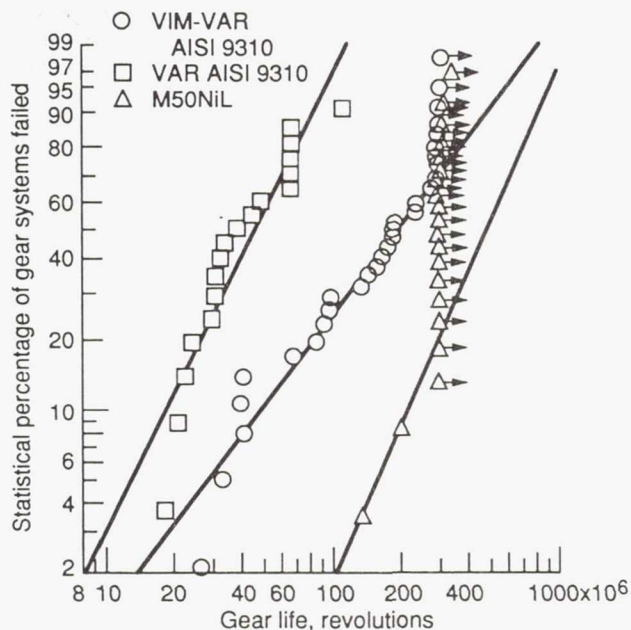

Figure 3.—Surface fatigue life of VAR and VIM-VAR AISI 9310 and M50NiL test gears. Speed, 10 000 rpm; maximum Hertz stress, 1.71 GPa (248 ksi); temperature, 350 K (170 °F); lubricant, synthetic paraffin with 5 vol% lubrizol 5002 (EP additive). Arrows denote suspension of tests.

When the rollers and the test bar were in thermal equilibrium at a bar temperature of ~305 K, the full load of 1250 N was applied to give the test bar a maximum Hertz stress of 4.83 GPa. When a fatigue failure occurred, the rig and related instrumentation were automatically shut down by a vibration detection system. The axial position of the test bar in the drive chuck was changed to a new running track before testing was resumed. Test results were also evaluated according to the methods of Johnson.⁹

RESULTS AND DISCUSSION

Gear Life Results

One lot each of VAR AISI 9310, VIM-VAR AISI 9310, and VIM-VAR M50NiL spur gears were endurance tested. Test conditions were a tangential load of 5.788 N/cm, which produced a maximum Hertz stress of 1.71 GPa, and a speed of 10 000 rpm. The gears failed by classical subsurface pitting fatigue. The pitting fatigue life results of these tests are shown in the Weibull plots of Fig. 3 and are summarized in Table V. These data were analyzed by the method of Johnson.⁹

The VAR AISI 9310 material exhibited 10- and 50-percent pitting fatigue lives of 18.8×10^6 and 46×10^6 stress cycles, respectively. The failure index was 18 out of 19. A typical fatigue spall that occurred near the pitch line is shown in Fig. 4(a). This spall is similar to those observed in rolling-element fatigue tests. The pitchline pitting is the result of high subsurface shearing stress, which develops subsurface cracks.

Pitting fatigue life results of the gears made from VIM-VAR AISI 9310 material are also shown in Fig. 3. The 10- and 50-percent surface fatigue lives were 48×10^6 and 200×10^6 stress cycles, respectively. The failure index was 24 out of 33. Nine suspensions did not fail after completing 500 hr of testing. The 10-percent life of the VIM-VAR AISI 9310 was more than two times, that of the VAR material. The confidence number for the 10-percent life level was 92.5 percent, which indicates that the difference is statistically significant. (The confidence number indicates the percentage of time the relative lives of the material will occur in the same order). These data indicate that for longer life the use of VIM-VAR AISI 9310 steel is preferred over VAR AISI 9310 steel.

TABLE V. - FATIGUE LIFE RESULTS FOR TEST GEARS AND ROLLING-CONTACT BARS

Material	System life, millions of stress cycles, 10 percent	Weibull slope	Confidence number at 10-percent life level, percent ^a
Gears:			
VAR AISI 9310	18.8	2.1	----
VIM-VAR AISI 9310	48	1.3	92.5
VIM-VAR M50NiL	217	2.3	99
Rolling-contact bars:			
VAR AISI 9310	4.2	2.3	----
VIM-VAR AISI 9310	6.84	2.26	76
VIM-VAR M50NiL	90.6	2.1	99

^aPercentage of time that the 10-percent life obtained with VAR AISI 9310 will have the same relation to the 10-percent life obtained with VIM-VAR AISI 9310 or VIM-VAR M50NiL.

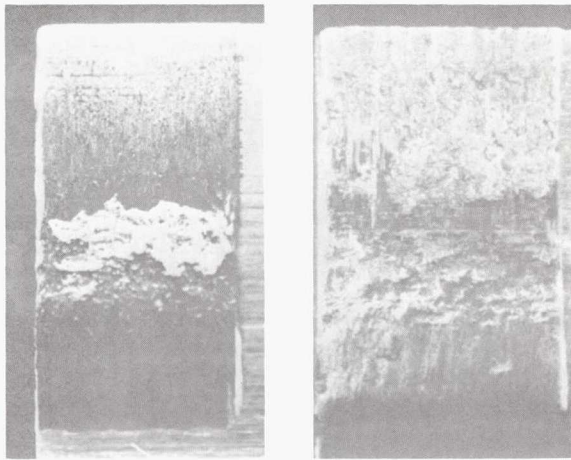

(a) AISI 9310 gears.

(b) M50NiL gears.

Figure 4.— Typical fatigue spall of AISI 9310 and M50NiL test gears. Speed, 10 000 rpm; maximum Hertz stress, 1.71 GPa (248 ksi); temperature, 350 K (170 °F); lubricant, synthetic paraffin with 5 vol % lubrizol 5002 (EP additive).

The pitting fatigue life results of the gears made from VIM-VAR M50NiL material are also shown in Fig. 3. The 10- and 50-percent surface fatigue lives were 217×10^6 and 496×10^6 stress cycles, respectively. The failure index was 2 out of 20. Eighteen suspensions ran 500 hr without failure. A typical fatigue spall for the VIM-VAR M50NiL gear is shown in Fig. 4(b). Some of the M50NiL gears were deliberately run with a surface fatigue spall for up to 12 additional hours without a tooth fracture occurring. This indicated that the M50NiL has a good fracture toughness since no tooth fractures occurred even though gears were run with fatigue spalls and thus increased dynamic loads. The 10-percent surface fatigue life of the VIM-VAR M50NiL was more than 11 times that of the VAR AISI 9310 and more than 4 times that of the VIM-VAR AISI 9310. The confidence numbers for the M50NiL were 99 percent compared with the VAR 9310 and 92.5 percent compared to the VIM-VAR 9310, both of which are statistically significant.

Rolling-Element Life Results

Test bars of VAR AISI 9310, VIM-VAR AISI 9310, and VIM-VAR M50NiL were tested in the RC fatigue tester. The test data were originally reported in Refs. 6 and 7. One lot of each material was tested. The RC bars were tested at a maximum Hertz stress of 4.83 GPa and a bar speed of 12 500 rpm. The RC tests were run at ambient temperature with a MIL-L-7808G lubricant. The results of these tests are shown in the Weibull plots of Fig. 5 and are summarized in Table V. These data were analyzed by the method of Johnson.⁹ A typical surface fatigue spall for an RC test specimen is shown in Fig. 6.

The VAR AISI 9310 RC test bars exhibited 10- and 50-percent pitting fatigue lives of 4.2×10^6 and 9.4×10^6 stress cycles, respectively. The failure index was 10 out of 10.

The VIM-VAR AISI 9310 RC test bars had 10- and 50-percent pitting fatigue lives of 6.84×10^6 and 15.74×10^6 stress cycles, respectively. The failure index was 10 out of 10. The confidence number for the difference in the 10-percent lives of the VAR and VIM-VAR 9310 test bars was 76 percent.

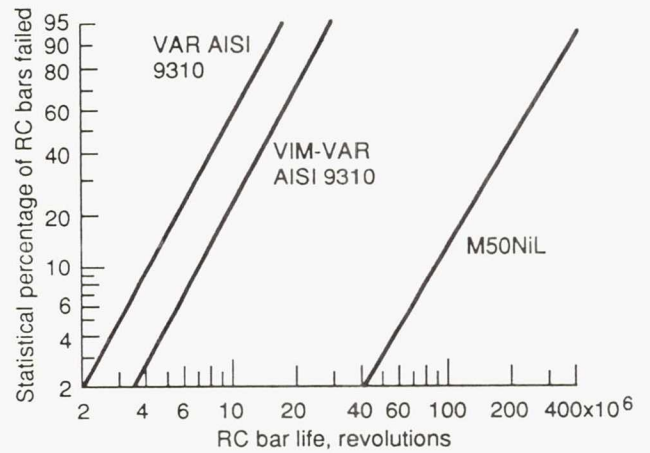

Figure 5.—Rolling-contact fatigue life of VAR and VIM-VAR AISI 9310 and M50NiL in rolling-contact fatigue tester. Maximum Hertz stress, 4.83 GPa (700 ksi); bar speed, 12 500 rpm; temperature, ambient; lubricant, MIL-L-7808G.

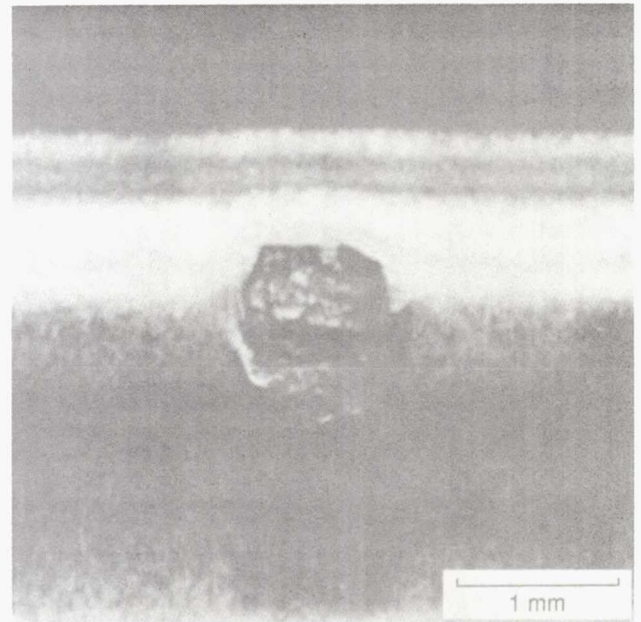

Figure 6.—Typical rolling-element fatigue failure.

The VIM-VAR M50NiL RC test bars had 10- and 50-percent pitting fatigue lives of 90.6×10^6 and 219×10^6 stress cycles, respectively. The failure index was 5 out of 20. The confidence number for the difference in life between the M50NiL bars and the VAR and VIM-VAR AISI 9310 was 99 percent, a statistically significant difference.

From the results of the data for the gear tests and the RC test bars for VAR AISI 9310, VIM-VAR AISI 9310, and VIM-VAR M50NiL it is concluded that the VIM-VAR 9310 material is superior to the VAR material for surface fatigue life. This conclusion was not unexpected since a cleaner steel would have fewer inclusions, where fatigue spalls tend to originate, and therefore longer fatigue life.

VIM-VAR M50NiL was shown to be far superior in life to either VAR or VIM-VAR AISI 9310, being

4.5 times the VIM-VAR 9310 for gears and 13.2 times the VIM-VIR 9310 for RC bars and 11.5 times the VAR 9310 for gears and 21.6 times the VAR 9310 for RC bars. These life differences are very large and indicate that the VIM-VAR M50NiL offers a significant advantage as a gear material over VIM-VAR AISI 9310. In addition the VIM-VAR M50NiL gear material exhibited good fracture toughness and thus is very attractive as a gear material. The higher temperature capability of the M50NiL 589 K also enhances this material for gear applications where this requirement is needed such as high-speed aircraft and aircraft that must operate for up 1 hr after loss of lubricant.

SUMMARY OF RESULTS

Spur gear endurance tests and rolling-element surface tests were conducted to investigate VIM-VAR M50NiL steel for use as a gear steel in advanced aircraft applications, to determine its endurance characteristics, and to compare the results with those for standard VAR and VIM-VAR AISI 9310 gear materials. Tests were conducted with spur gears and rolling-contact (RC) bars manufactured from VIM-VAR M50NiL and VAR and VIM-VAR AISI 9310. The gear pitch diameter was 8.9 cm. Gear test conditions were an inlet oil temperature of 320 K, an outlet oil temperature of 350 K, a maximum Hertz stress of 1.71 GPa, and a speed of 10 000 rpm. Bench rolling-element fatigue tests were conducted at ambient temperature with a bar speed of 12 500 rpm and a maximum Hertz stress of 4.83 GPa.

The following results were obtained:

1. The VIM-VAR M50NiL test gears had a 10-percent surface fatigue life that was 4.5 times that of the VIM-VAR AISI 9310 and 11.5 times that of the VAR AISI 9310 material.
2. The VIM-VAR M50NiL RC test bars had a 10-percent surface fatigue life that was 13.2 times that of the VIM-VAR AISI 9310 and 21.6 times that of the VAR AISI 9310 material.
3. The VIM-VAR M50NiL was shown to have good resistance to fracture through a fatigue spall in a gear tooth and to have fatigue life far superior to that of VAR and VIM-VAR AISI 9310 in both gear and RC bar tests.

References

1. Parker, R.J., Bamberger, E.N., and Zaretsky, E.V., "Bearing Torque and Fatigue Life Studies With Several Lubricants for Use in Range 500 °F to 700 °F," NASA TN D-3948, 1967.
2. Bamberger, E.N., Zaretsky, E.V., and Anderson, W.J., "Effects of Three Advanced Lubricants on High-Temperature Bearing Life," *Journal of Lubrication Technology*, Vol. 92, No. 1, Jan. 1970, pp. 23-33.
3. Townsend, D.P., Parker, R.J., and Zaretsky, E.V., "Evaluation of CBS 600 Carburized Steel as a Gear Material," NASA TP-1390, 1979.
4. Townsend, D.P., and Zaretsky, E.V., "Endurance and Failure Characteristics of Modified VASCO X-2, CBS 600 and AISI 9310 Spur Gears," *Journal of Mechanical Design*, Vol. 103, No. 2, Apr. 1987, pp. 505-515. (NASA TM-81421).
5. Townsend, D.P., "Surface Fatigue Life and Failure Characteristics of EX-53, CBS 1000 M and AISI 9310 Gear Materials," NASA TP-2513, 1985.
6. Bamberger, E.N., and Kroeger, D.J., "Rolling Element Fatigue Life of a Carburized Modified M50 Bearing Steel," NASA CR-168295, 1984.
7. Nahm, A.H., "Rolling Element Fatigue Testing of Gear Materials," R78AEG476, General Electric, Cincinnati, OH, 1978, NASA CR-135450.
8. Dowson, D., and Higginson, G.R., *Elasto-Hydrodynamic Lubrication*. Pergamon Press, New York, 1966.
9. Johnson, L.G., *The Statistical Treatment of Fatigue Experiments*. Elsevier Publication Co., New York, 1964.

1. Report No. NASA TM-104496 AVSCOM TR-91-C-034		2. Government Accession No.		3. Recipient's Catalog No.	
4. Title and Subtitle Surface Fatigue Life of M50NiL and AISI 9310 Spur Gears and R C Bars				5. Report Date	
				6. Performing Organization Code	
7. Author(s) Dennis P. Townsend and Eric N. Bamberger				8. Performing Organization Report No. E-6353	
9. Performing Organization Name and Address NASA Lewis Research Center Cleveland, Ohio 44135-3191 and Propulsion Directorate U.S. Army Aviation Systems Command Cleveland, Ohio 44135-3191				10. Work Unit No. 505-63-36 1L162211A47A	
				11. Contract or Grant No.	
12. Sponsoring Agency Name and Address National Aeronautics and Space Administration Washington, D.C. 20546-0001 and U.S. Army Aviation Systems Command St. Louis, Mo. 63120-1798				13. Type of Report and Period Covered Technical Memorandum	
				14. Sponsoring Agency Code	
15. Supplementary Notes Prepared for the International Conference on Motion and Power Transmissions sponsored by the Japan Society of Mechanical Engineers with participation of ASME, I. Mech. E., VDI, I.E.T., CSME and other societies, Hiroshima, Japan, November 24-26, 1991. Dennis P. Townsend, NASA Lewis Research Center; Eric N. Bamberger, General Electric Company, Cincinnati, Ohio.					
16. Abstract Spur gear endurance tests and rolling-element surface fatigue tests were conducted to investigate vacuum-induction-melted, vacuum-arc-remelted (VIM-VAR) M50NiL steel for use as a gear steel in advanced aircraft applications, to determine its endurance characteristics, and to compare the results with those for standard VAR and VIM-VAR AISI 9310 gear material. Tests were conducted with spur gears and rolling-contact bars manufactured from VIM-VAR M50NiL and VAR and VIM-VAR AISI 9310. The gear pitch diameter was 8.9 cm (3.5 in.). Gear test conditions were an inlet oil temperature of 320 K (116 °F), an outlet oil temperature of 350 K (170 °F), a maximum Hertz stress of 1.71 GPa (248 ksi), and a speed of 10 000 rpm. Bench rolling-element fatigue tests were conducted at ambient temperatures with a bar speed of 12 500 rpm and a maximum Hertz stress of 4.83 GPa (700 ksi). The VIM-VAR M50NiL gears had a surface fatigue life that was 4.5 and 11.5 times that for VIM-VAR and VAR AISI 9310 gears, respectively. The surface fatigue life of the VIM-VAR M50NiL rolling-contact bars was 13.2 and 21.6 times that for the VIM-VAR and VAR AISI 9310, respectively. The VIM-VAR M50NiL material was shown to have good resistance to fracture through a fatigue spall and to have fatigue life far superior to that of both VIM-VAR and VAR AISI 9310 gears and rolling-contact bars.					
17. Key Words (Suggested by Author(s)) Gears Fatigue life Rolling contact loads			18. Distribution Statement Unclassified - Unlimited Subject Category 37		
19. Security Classif. (of the report) Unclassified		20. Security Classif. (of this page) Unclassified		21. No. of pages 8	22. Price* A02