

N91-28118

CHARACTERIZATION OF QUANTUM WELL STRUCTURES USING A PHOTOCATHODE ELECTRON MICROSCOPE

M.G. Spencer
Department of Electrical Engineering
Howard University
Washington, D.C.

C.J. Scott
Naval Research Laboratory

555-76
26636
P-4

Introduction

Present day integrated circuits pose a challenge to conventional electronic and mechanical test methods. Feature sizes in the submicron and nanometric regime require radical approaches in order to facilitate electrical contact to circuits and devices being tested. In addition, microwave operating frequencies require careful attention to distributed effects when considering the electrical signal paths within and external to the device under test. In this paper an alternative testing approach which combines the best of electrical and optical time domain testing will be presented, namely photocathode electron microscope quantitative voltage contrast (PEMQVC).

Comparison of Test Methods

High speed electrical characterization of microstructures using a stroboscopic quantitative voltage contrast electron beam probe has advantages over mechanical and optical methods. For comparison the photocathode electron microscope and other time domain test methods are listed in table 1.[1]. It can be seen that the PEMQVC offers superior spatial and temporal resolution at the expense of voltage accuracy. Electro-optic probing eliminates some of the spatial transition problems which can introduce considerable error in high frequency mechanical probe measurements. Alternatively, when characterizing micron scale structures, electron beam testing has the following advantages over the electro-optical method: 1) the spatial resolution of the electron beam is limited to the minimum primary gaussian electron beam current waist (typically $\geq 80\text{\AA}$) as compared to the diffraction limited beam waist of monochromatic light (typically $\geq 1\mu\text{m}$), 2) the sampling media is not limited to materials with intrinsic birefringence such as GaAs and LiTaO₃ so that silicon, InP and other materials with low electrooptic figures of merit can be tested, and 3) the necessity of gold coating and polishing the backside of the test sample is eliminated.

PEMQVC Components

A standard SEM is modified by: 1) replacing the conventional thermionic electron gun with a photo-excited electron gun, 2) enhancing the SE detector electrostatic environment to measure the energy spectrum of the scattered secondary electrons, and 3) providing feed-throughs for electrical signals. Schematic diagrams of a conventional SEM and the photocathode electron microscope are shown in Figure 1. The instrument can be used in a dual mode for either conventional SEM work or time domain characterization if the SEM conversion is done properly. A circuit can be examined for visual defects and then exercised at speed functionality evaluation. There are three different test modes the photocathode electron microscope can operate in: 1) static voltage contrast, 2) quantitative voltage contrast, and 3) stroboscopic voltage contrast. The first mode gives a qualitative indication of voltage levels on the sample. The second mode gives a quantitative voltage for the sample but no time domain information. The third mode gives both voltage and time quantitatively.

The photostated provides a picosecond electron source by photoemission of electrons using a frequency quadrupled Nd Yag (1.06 μm) laser source. A KDP crystal is used for the first frequency doubling stage and a BBO crystal is used for the second frequency doubling stage. BBO is an efficient second harmonic generation medium for the 532/266 nm doubling process. The emission surface is a 200Å thick Au layer on a polished 40 mm Al_2O_3 substrate. The photo cathode is held at the primary electron acceleration potential ($\sim 1\text{KV}$).

A Feuerbaum [2] or planar type detection scheme is used to quantize the SE spectral shift (Fig. 2). This type of analyzer simplifies the electrostatic field pattern analysis for detector refinement for achieving higher measured signal resolution. The retarding potential sets the lower limit of integration for the photomultiplier tube (PMT). The nonlinear photomultiplier tube (PMT) "S curve" currents are linearized using a computer controlled feedback loop to establish the required retarding potential to maintain a preset PMT output current. The retarding potential is equal to the sample potential. Temporal delay is implemented on the optical bench with a right angle prism on a sliding optical rail.

Summary

The electron beam testing apparatus will provide direct experimental verification for numerical simulations and a means of contactless probing of devices and interconnects at spatial and temporal resolutions not achievable by any other means. When the flexibility and high spatial resolution of the electron beam technique is combined with the inherent high speed capabilities of optical pulse generation, this contactless probing method may prove to be an essential tool in any integrated circuit research and development facility.

References

- [1] G. Chiu, J. Halbout, and P. May, J. Vac. Sci. Technol. 6,1814 (1988)
- [2] H.P. Feuerbaum, SEM/I, pp. 285-296, (1979)

	t_r	V_r	x	Jitter
Superconductive	20ps	$1\mu\text{V}/\sqrt{\text{Hz}}$	100um	5ps
Analog	25ps	$7\mu\text{V}/\sqrt{\text{Hz}}$	100um	10ps
E-Beam Strobe	100ps	$3\text{mV}/\sqrt{\text{Hz}}$	0.1um	10ps
E-Beam Photo	5ps	$3\text{mv}/\sqrt{\text{Hz}}$	0.1um	5ps
E/O Sampling	5ps	$5\mu\text{V}/\sqrt{\text{Hz}}$	3um	5ps

Table 1.
Time domain measurement comparison.

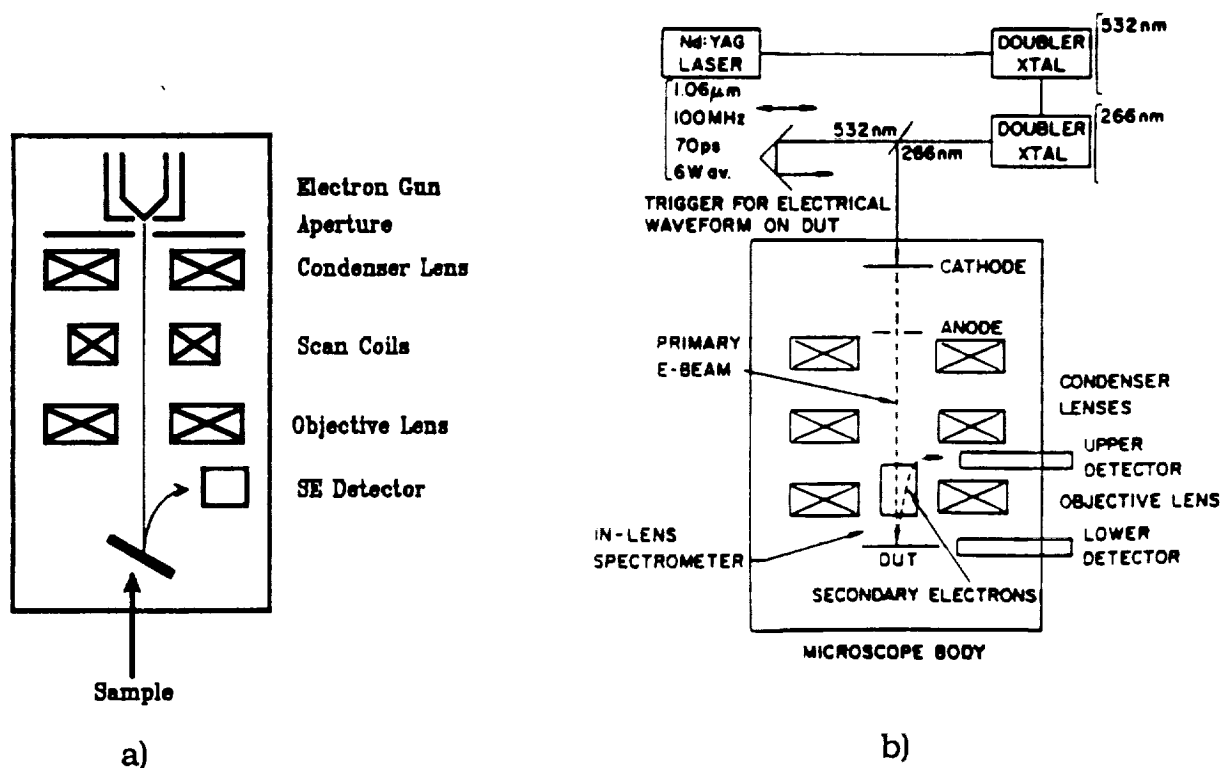
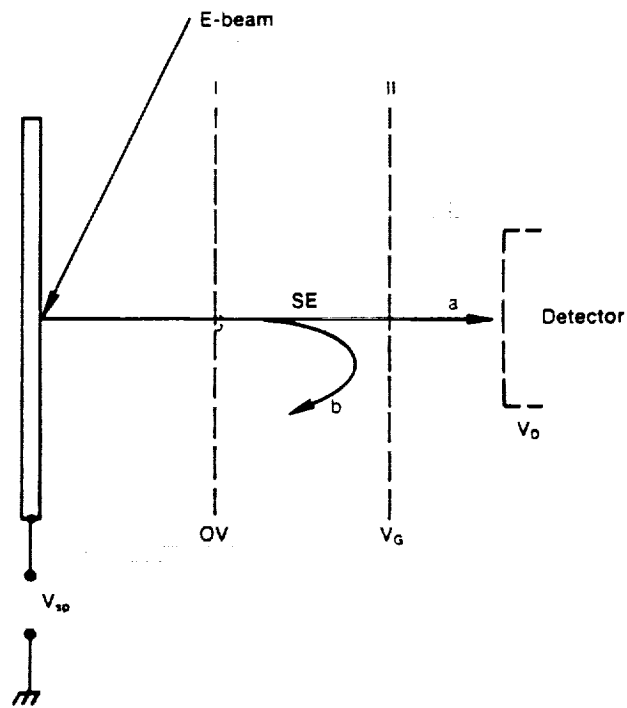

Figure 1.
Schematic diagrams of
a) a conventional SEM and
b) a photocathode electron microscope.



$$I_{SED} = I_{SEmax} \int_{eV_G}^{50eV} N(E + eV_{sp}) dE$$

Figure 2.
A Feuerbaum type SE detector.