

PRESENTATION 2.3.5

N 9 1 - 2 8 2 3 3

**OPTICAL DIAGNOSTIC INVESTIGATION
OF LOW REYNOLDS NUMBER NOZZLE FLOWS**

OPTICAL DIAGNOSTIC INVESTIGATION OF LOW REYNOLDS NUMBER NOZZLE FLOWS

Michael M. Micci
Department of Aerospace Engineering

I. Research Objectives and Potential Impact on Propulsion

Small high performance chemical rocket motors and electric propulsion devices operating at low power levels (<25 kW) suffer from high nozzle losses due to the low Reynolds number of the exhaust flow. The Reynolds number with the diameter of the nozzle throat as the characteristic dimension is:

$$\text{Re} = \frac{\rho u D}{\mu}$$
$$\propto \frac{DP_o}{T_o}$$

As chemical and electric thruster research and development strives for higher chamber temperatures to increase performance, the future trend for nozzles will be for decreasing Reynolds numbers. Current methods for estimating rocket nozzle performance assume a boundary layer along the interior wall with an inviscid core. However at low Reynolds numbers the wall boundary layer fills most if not all of the nozzle interior producing a large amount of viscous dissipation. Nozzle efficiency, the ratio of the delivered specific impulse to the ideal specific impulse, has been measured as low as 60% at a Reynolds number of 200. Computational techniques are beginning to be able to examine such flows but the need exists for experimental verification of both numerical results as well as design changes in existing hardware.

The majority of experimental measurements to date have consisted of thrust and discharge coefficient, both global quantities which give little information about the detailed physical processes occurring. Different studies looking for the optimal nozzle wall contour for low Reynolds number flow among cones of various angles, bell-shaped nozzles and trumpet-shaped nozzles, reached different conclusions. The only detailed measurements of flow properties were taken by Rothe using an electron beam diagnostic in a low pressure nozzle flow. Rothe measured density and temperature as a function of axial and radial location in the nozzle and found that for low flow Reynolds numbers the static temperature would rise in the nozzle expansion due to viscous dissipation.

The objectives of this program are to obtain temperature, density and velocity profile measurements in the expansion region of low Reynolds number nozzles through the use of optical diagnostics. An LIF system will be used to probe the expansion of a microwave-heated expansion in the Center vacuum facility. The experimental measurements made in this program will be compared to numerical predictions obtained by Drs. Charles Merkle and Lyle Long.

II. Current Status and Results

The majority of the effort expended to date in this program has been involved in the build-up of the Center vacuum facility. The vacuum chamber has a 1 meter inside diameter and is 5 feet long. Figure 1 is a diagram of the vacuum chamber with pump, microwave gas heater and LIF system. The Stokes mechanical pump and the Stokes diffusion pump were installed and connected with their requisites utilities, electricity, cooling water and exhaust vents, this past year. To date, the pumps have achieved a minimum pressure of $1.9 \cdot 10^{-4}$ Torr with no mass flow through the system. This corresponds to an altitude of 101 km. The diffusion pump has a zero flow rate specification of 10^{-4} Torr. Small leaks through the mounting threads of the two pressure transducers prevented a lower pressure from being achieved. Since both these pressure transducers were in temporary positions above the diffusion pump and are being relocated in the vacuum chamber, an extensive effort to seal these threads was not undertaken. However, new fittings for these transducers which will provide better high vacuum sealing are being procured.

With the check-out of the diffusion pump completed, the vacuum chamber has been mated with the diffusion pump.

A tunable laser system for use as a pump source for an LIF system has been identified. A Quanta-Ray pulsed Nd:YAG laser will be frequency doubled and used as the pump for a Quanta-Ray pulsed dye laser. This will provide an output at wavelengths of 654-647 nm for use in pumping the First Positive system of N_2 . The output of the dye laser will be frequency doubled again to reach the 337 nm wavelength to excite the Second Positive system of N_2 . Nitrogen has been chosen because its molecular nature will allow the examination of nozzle frozen flow losses due to nonequilibrium effects.

The LIF system will be used to obtain simultaneous measurements of temperature, density and velocity in the expansion flows from low Reynolds number nozzles. Density will be obtained from the absolute intensity integrated over the entire fluorescing line. An Optronics calibrated tungsten strip lamp has been procured and has been used successfully for emission spectroscopy absolute continuum measurements of the electron temperature in a microwave-heated helium plasma. Temperature of the heavy particles (neutrals and ions) will be obtained by measuring the Doppler broadened linewidth of fluorescing lines. Figure 2 shows the amount of Doppler broadening (including Stark broadening) for the Second Positive system of N_2 as a function of temperature. An electronically tunable Fabry-Perot etalon has been procured this past year which when combined with the Spex 0.5 meter monochromator which was purchased with funding from a prior grant should give a frequency resolution of 0.004 Angstroms.

The velocity of the gas will be determined from the Doppler shift of the fluorescing lines. Figure 3 plots the Doppler line shift of the 337 nm line of the Second Positive system for N_2 as a function of velocity. It can be seen by comparing Figures 2 and 3 that the Doppler line shift is much greater than the Doppler broadening, thus the broadening will not interfere with the velocity measurement.

Since the laser system is to be procured during the next fiscal year, the Fabry-Perot etalon is initially being used to measure the Doppler broadening and line shift of emitting lines to determine the temperature and velocity of a microwave-heated plasma expanding to atmospheric pressure and a velocity of Mach 1. Figure 4 is a drawing of the experimental system being used to make these measurements. The emitted light from the exhaust plume will be collected in the direction of the velocity measurement and compared to light collected in a direction where the gas has no directed velocity to determine the Doppler shift. The Fabry-Perot etalon is used as a very narrow bandwidth optical filter.

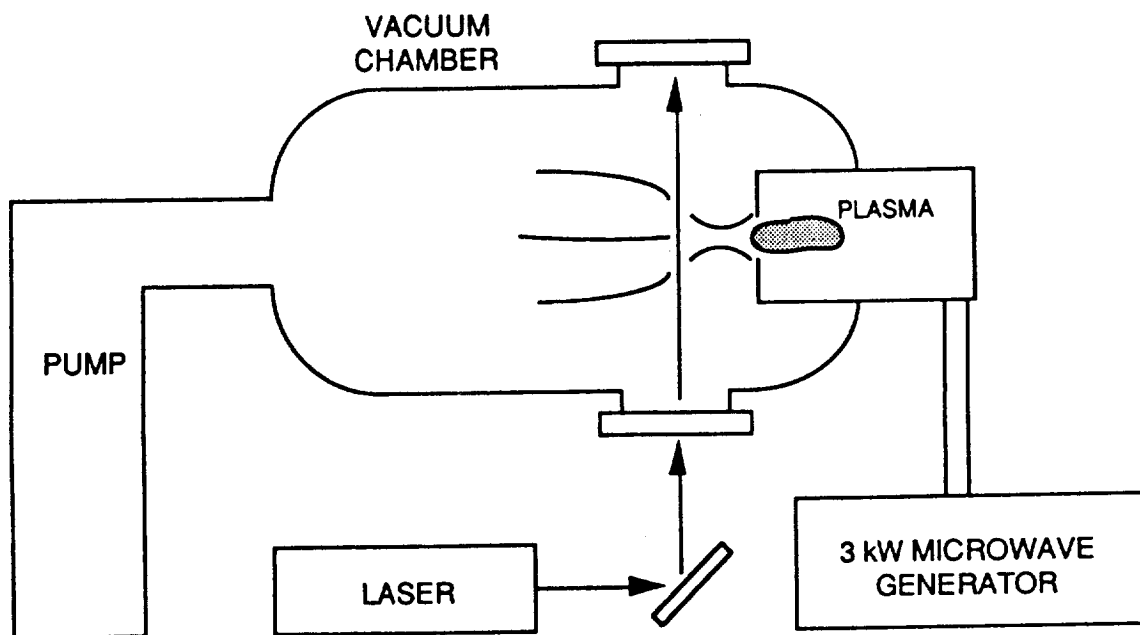

Fig. 1 Diagram of experimental facility to optically examine nozzle flows.

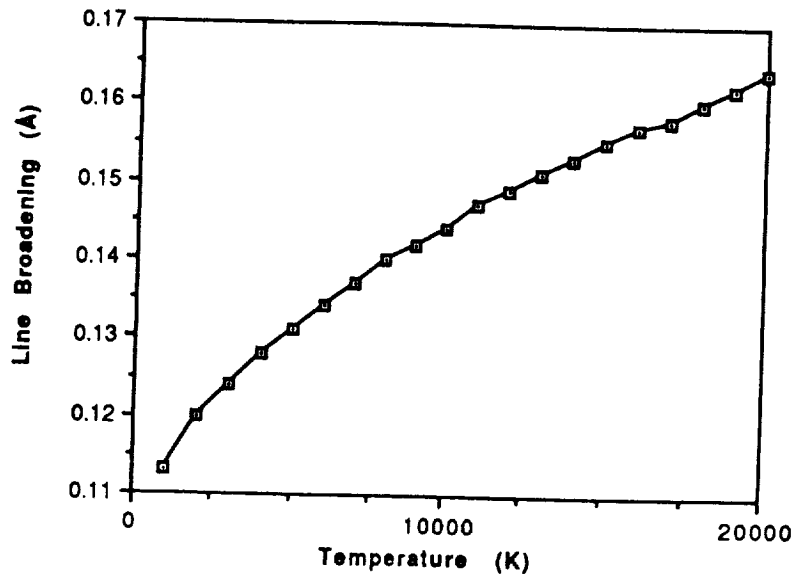

Fig. 2 Doppler line broadening for the 337 nm line of N_2 as a function of temperature.

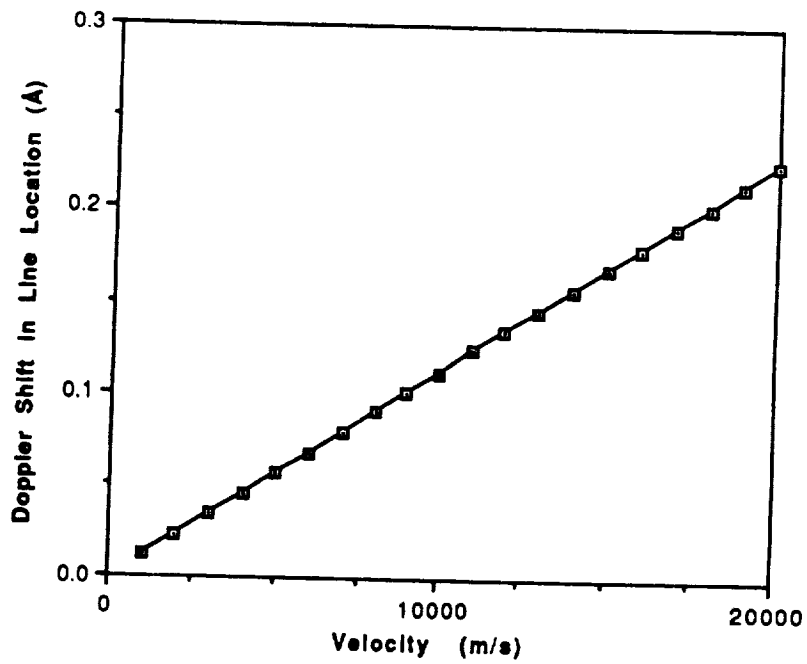

Fig. 3 Doppler line shift for the 337 nm line of N_2 as a function of velocity.

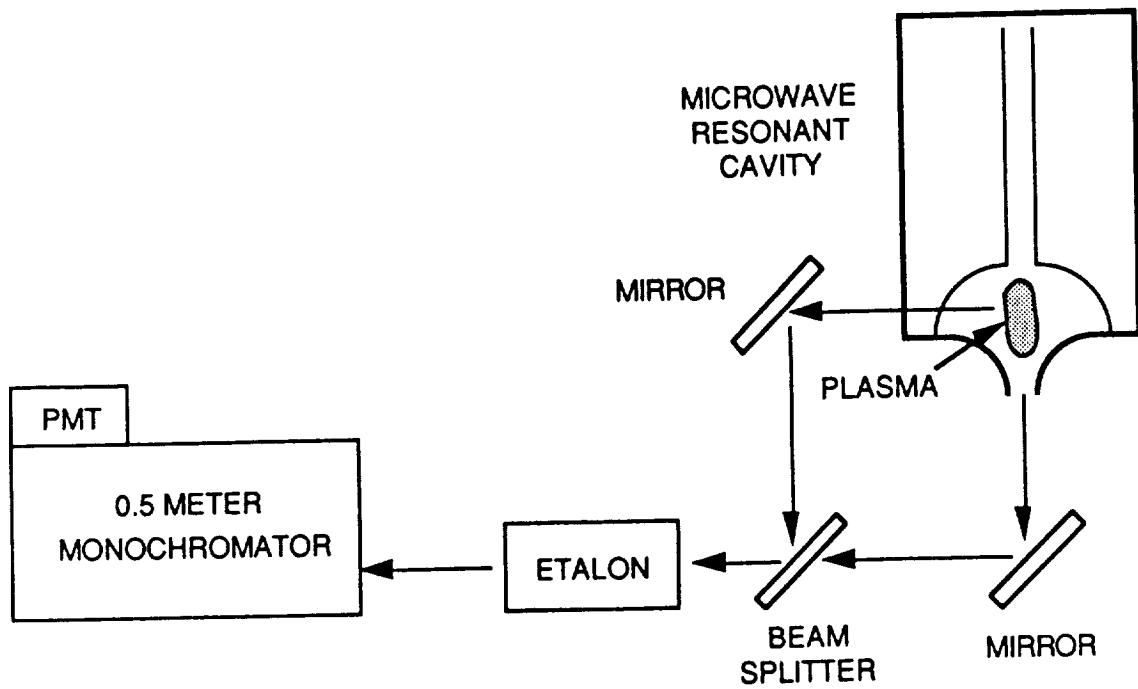

Fig. 4 Experiment to use Fabry-Perot etalon to measure Doppler line broadening and Doppler line shift of emitting microwave-heated plasma.

III. Proposed Work for Coming Year

The Stokes mechanical and diffusion pumps will be operated with the vacuum chamber attached and the minimum obtainable pressure as a function of mass flow rate and gas composition into the chamber will be measured. Early success with no gas flow through the system indicates that a good vacuum should be obtainable with experimentally significant mass flows. A fitting for the high vacuum pressure transducer which seals by the use of two O-rings instead of thread sealant is being procured and should solve the leakage problems experienced during the pump testing.

The interim tunable laser system being shared with Dr. Santoro for the LIF diagnostic should be in place in an adjacent laboratory by July 1, 1990. A system will be designed and constructed to divert the output beam through an opening in the wall between the laboratories into the window of the vacuum chamber which is located approximately nine feet above the laboratory floor. The laser beam will be intentionally reflected just prior to entering the window in order to aim it at the location of interest in the chamber. Additional windows are located on the chamber at positions opposite and perpendicular to the window through which the beam is entering while the nozzle exhaust is directed along the axis of the chamber.

The operation of the electronically tunable Fabry-Perot etalon as a very narrow bandwidth optical filter to measure Doppler broadened linewidths and Doppler shifts will be tested in an emission spectroscopy system. Gas will be heated to temperatures between 10,000 and 13,000 K in a microwave resonant cavity and accelerated to sonic velocities by expanding through a converging nozzle to atmospheric pressure. The principle disadvantage of emission spectroscopy compared to LIF is that emission spectroscopy is a line of sight measurement whereas LIF is a point measurement. Thus the initial results with the Fabry-Perot etalon will be somewhat degraded because of the averaging taking place through the measuring volume.

A circular microwave waveguide capable of applying the full 2.5 kW which is available to heat a gas is scheduled for delivery early in the grant year. A rectangular waveguide was used in prior experiments, however a rectangular waveguide generates a plasma which is attached at two locations to the waveguide walls. In order to generate a plasma which is not in contact with the waveguide walls, a circular waveguide was designed which will generate a plasma which is located along the waveguide axis. It will initially be tested with a choked converging nozzle expansion to atmospheric pressure and then integrated with the end flange of the vacuum chamber for expansions through converging-diverging nozzles to low pressures.

Finally, the use of LIF to measure density, temperature and velocity in the supersonic exhaust region of a microwave-heated gas flow will be evaluated. The laser will be used to excite the gas and the Fabry-Perot etalon in conjunction with the 0.5 meter monochromator will be used to measure the fluorescence signal. Spatial profiles of density, temperature and velocity in the radial direction will be measured. Initial nozzle geometries will be conical and property variations in the axial direction will be obtained by testing with nozzles of varying expansion ratios. Eventually, different nozzle contours such as bell and trumpet shaped will be tested.