

7-16-11
E6487

NASA Technical Memorandum 105187

The NASA Lewis Research Center Internal Fluid Mechanics Facility

A.R. Porro, W.R. Hingst, C.A. Wasserbauer,
and T.B. Andrews
*Lewis Research Center
Cleveland, Ohio*

September 1991



The NASA Lewis Research Center Internal Fluid Mechanics Facility

A. R. Porro, W. R. Hingst, C. A. Wasserbauer, and T. B. Andrews
*NASA Lewis Research Center
Cleveland, Ohio 44135*

Introduction

Current research efforts at NASA Lewis Research Center are focused towards a better understanding of the physics of internal duct flows that are encountered in aircraft engine applications. These include both engine inlet diffuser ducts and nozzle transition ducts.

Aircraft engine inlet diffuser ducts are used both for inlet flow diffusion and total pressure recovery as well as directing the inlet flow to the gas turbine compressor face. These diffusers tend to have complicated geometries which may lead to undesired flow distortion at the compressor face if not designed properly. In addition to cross-sectional area changes of the duct, there may be geometric changes where the duct cross section may transition from a rectangular or 'D' shape at the inlet to a circular cross section at the exit. The flow physics may be further complicated by the addition of bends in the duct required by the engine-airframe integration process.

The current research interest in nozzle transition ducts leans towards those that have a geometric cross-sectional change from initially circular to superelliptical at the duct exit. These ducts are used for two-dimensional thrust vectoring nozzle applications. Since the interface region between the aircraft engine and nozzle is limited in length, these ducts are designed such that the geometry transition is accomplished in a minimum of streamwise distance, so a potential for flow separation exists.

In order to design these ducts efficiently and cost effectively, designers are beginning to use CFD codes to predict the aerodynamic characteristics of these ducts with limited success. However, some of these duct designs are non-axisymmetric and produce highly three-dimensional internal flows, so more advanced CFD techniques must be developed to predict the performance of these duct designs. As these advanced CFD techniques emerge, fundamental internal duct flow experiments must be conducted to generate a CFD code calibration database. An experimental facility has been built here at NASA Lewis Research Center to meet this need. That is, the Internal Fluid Mechanics Facility has been designed specifically for testing of duct type flows. This purpose of this paper is to describe this facility in detail.

Facility Description

A photograph of the Internal Fluid Mechanics Facility is shown in Fig. 1, and a facility schematic is shown in Fig. 2. The facility consists of three main components: (1) the settling chamber, (2) the test region, and (3) the exhaust region. The facility is connected to a laboratory-wide sub-atmospheric exhaust system which generates pressure ratios necessary to allow flow through the facility. The current configuration, as shown in Fig. 1, uses ambient air as the supply pressure source for the facility. However, there are provisions to connect the settling chamber to a laboratory-wide high pressure air supply system in order to operate the facility at higher pressure ratios and mass flow rates. Use of the laboratory-wide air supply and exhaust system gives this facility the capability to run continuously.

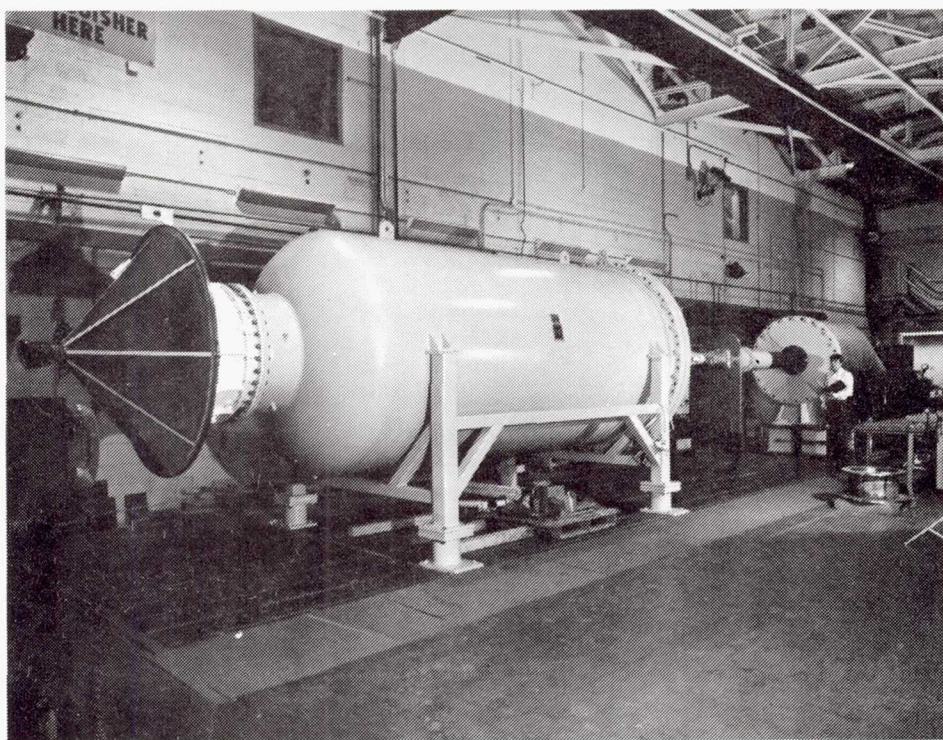

Figure 1. Photograph of Internal Fluid Mechanics Facility.

Settling Chamber

The settling chamber, or plenum, is used to diffuse and condition the incoming flow to the test region. The facility air intake is located in line with the flow axis of the facility and is used to direct the incoming air into the plenum portion of the settling chamber. The bellmouth assembly shown in Fig. 1 is mounted to the external portion of the air intake when using ambient air as the supply air. When using the laboratory

high pressure air supply, the bellmouth is replaced by an air supply line that attaches directly to the facility air intake.

The plenum has an axisymmetric design with a circular cross section. As shown in Fig. 2, a perforated spreader cone is installed near the plenum entrance to insure proper diffusion and mixing of the incoming flow throughout the plenum. This approach was suggested by Pope and Goin [1].

At station 7.5 a coarse one-half mesh flow conditioning screen is used to reduce the mean flow nonuniformities after the flow exits the perforated cone. Farther downstream at station 14.75, a honeycomb/screen combination is used to remove the small scale turbulence in the flow just before it enters a contraction section. This flow conditioning configuration was suggested by Burley and Harrington [2].

A contraction section is used to transition the flow from the plenum into the facility test region. The nominal diameter of the plenum is 5 ft. while the nominal diameter of the contraction section at the test region entrance is nominally 8 in. This yields a rather large area contraction ratio of 59. This large contraction ratio ensures a uniform flowfield at the entrance of the test region. Appendix A discusses the plenum aerodynamic components in detail.

Test Region

The next section of the Internal Fluid Mechanics Facility is the test region where the experimental hardware is installed. The test region is very versatile in the sense that any duct flow hardware can be installed in this region as long as proper interfaces are designed to mate the test hardware to the settling chamber and diffuser regions of the facility. The test region allowable maximum length is approximately 15 ft. Therefore, the experimental hardware must be designed to fit within this dimension. However, in order to use the facility without a major redesign of the exhaust region as shown in Fig. 2, the experimental hardware can have a maximum length of 9.67 ft. and a minimum length of only 6.17 ft.

Fig. 3 shows a typical experimental hardware installation in the facility. In this case, a nozzle transition duct is installed in the facility. The cross section of the duct is initially circular and transitions to a superelliptic (nominally rectangular) cross section at the duct exit. In addition to the transition duct, two additional experimental components are installed in the test region.

The first additional component is an 8.04 in. diameter constant area circular duct 30 in. in length. It is used as an interface between the settling chamber contraction section and the transition duct and also allows a turbulent boundary layer to develop. This duct is available for use with subsequent model hardware. In fact, the flowfield measurements that document the facility flow quality were made in this duct. These results will be presented in a later section of this report.

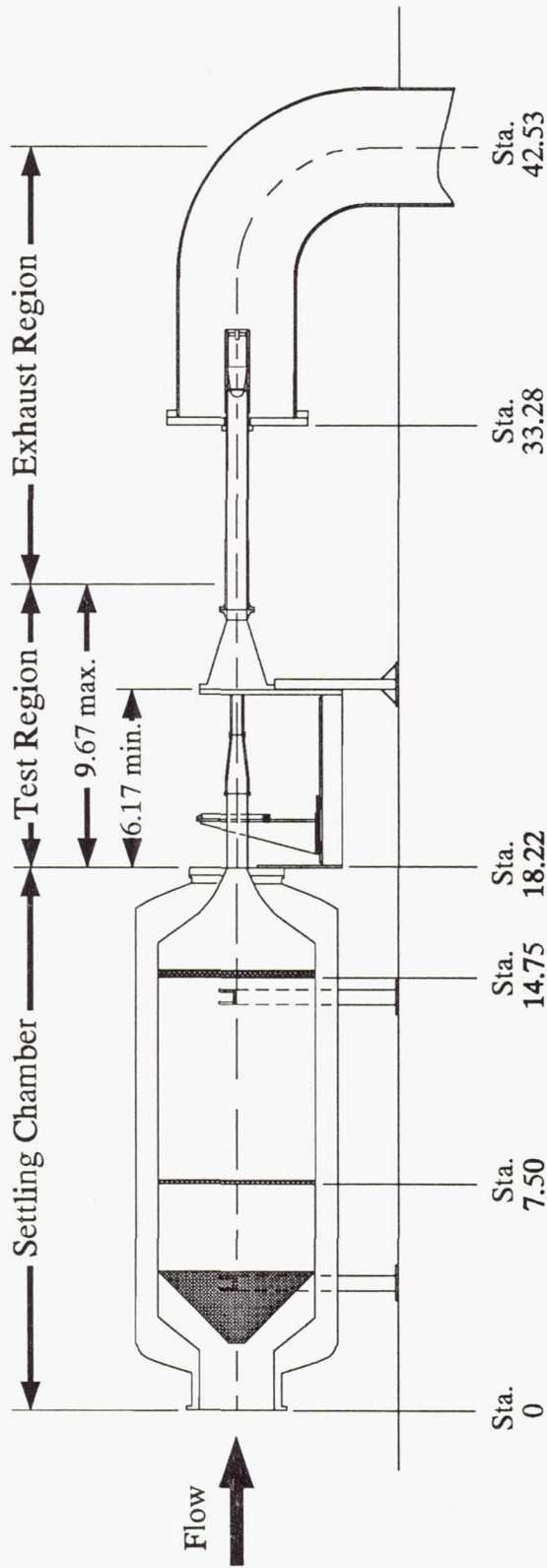

Figure 2. Schematic of Internal Fluid Mechanics Facility. Dimensions are given in feet.

The other additional component for this experiment is a superelliptic downstream duct that is used to connect the transition duct to the diffuser portion of the facility. This duct is specifically designed for this experiment and probably would not be used in later experiments. This is typical of the kind of hardware/facility interfaces used and that should be considered when designing an experiment for this facility. A detailed discussion of the model hardware/facility interfaces is found in Appendix B.

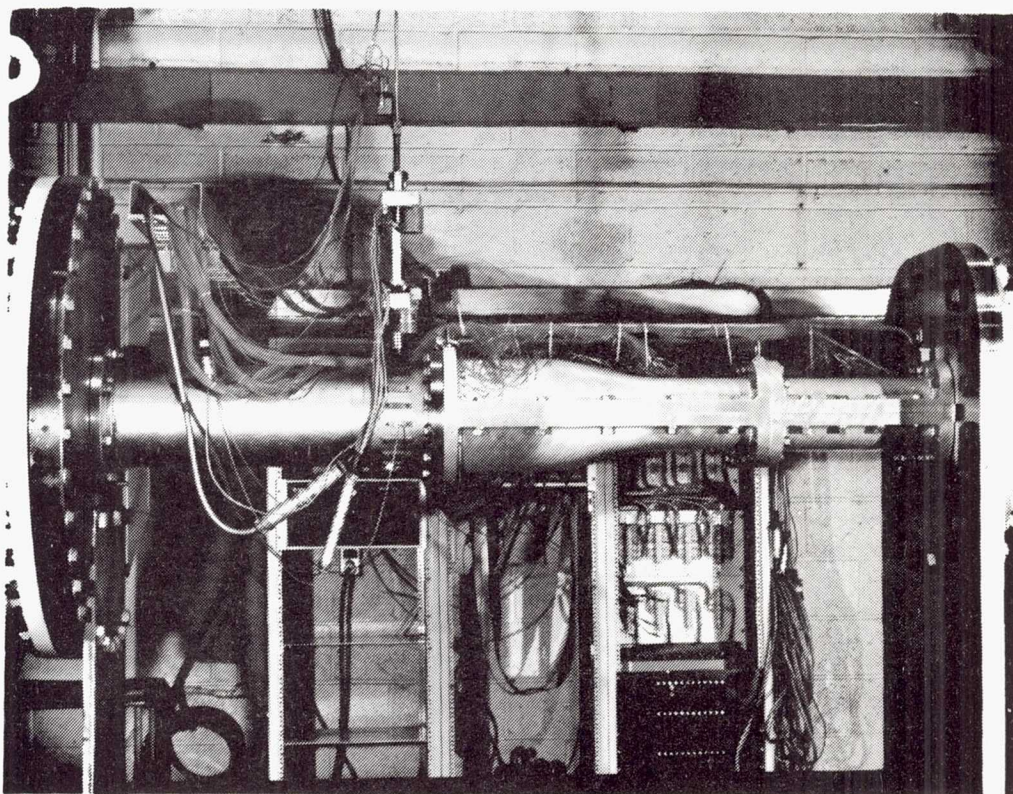

Figure 3. Photograph of the transition duct experiment hardware installed in the Internal Fluid Mechanics Facility.

Exhaust Region

The final section of the Internal Fluid Mechanics Facility is the exhaust region. Its primary function is to direct the air flow into the laboratory-wide sub-atmospheric exhaust system after exiting the facility test region. Since the laboratory exhaust system has the capability of maintaining a stable sub-atmospheric exhaust pressure for very high mass flow rates, the exhaust portion of the facility does not necessarily have to be designed to act as an efficient diffuser.

For the transition duct experimental hardware installation, the exhaust region as shown in Fig. 4 uses a conical transition piece with an inlet diameter of 18 in. and exit diameter of 10 in. which is used to connect the experimental hardware to the facility exhaust system. A mating flange with a superelliptical cut out is attached to the upstream end of this exhaust transition piece. A circular pipe is connected to the downstream side

of the exhaust transition piece and is used to direct the flow into the laboratory exhaust system. This pipe houses an adjustable mass flow plug which is used to control the airflow throughout the entire facility.

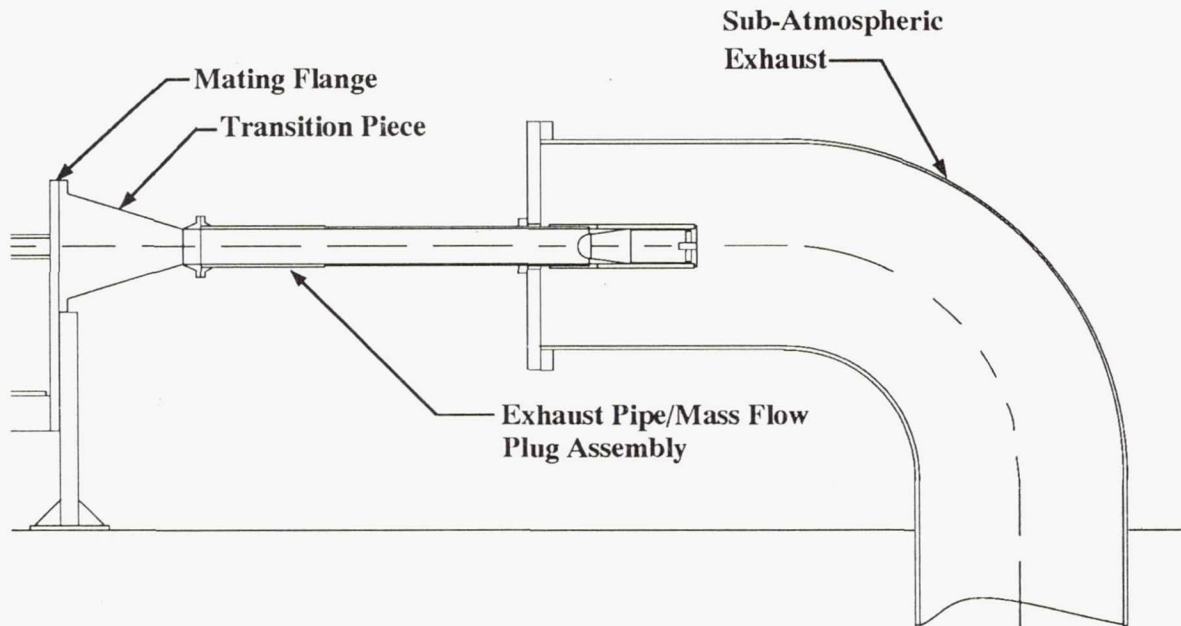

Figure 4. Schematic of facility exhaust region.

The circular exhaust pipe is designed to be moved along its axial centerline to accommodate a range of test model lengths. If a model longer than 9.67 ft. must be tested in the facility, the existing exhaust pipe/mass flow plug assembly cannot be used, and a suitable replacement must be designed to act as an experimental hardware/facility interface and flow control device.

A large 48 in. flange is used as an interface between the Internal Fluid Mechanics Facility and the laboratory exhaust system. As shown in Fig. 2, it is located at Station 33.28. This flange can be replaced with redesigned flanges in order to accommodate future experiments. For example, if a duct were to be tested whose exit plane is not aligned with the inlet plane such as is found in 'S' diffusers, a new exhaust mating flange can be designed with the exhaust opening offset from the facility centerline.

Instrumentation and Data Acquisition Capability

Facility test data such as pressure measurements, temperature measurements, and various analog data are gathered by a microcomputer-based data acquisition system called ESCORT II, which is a standard at NASA Lewis. This system monitors and displays important test parameters in near real time with three second updates of the data. When a data point is recorded, the ESCORT II system essentially stores a "snapshot" of the data for future data reduction and analysis. Because of the relatively slow updates of this data system, only steady flow data can be acquired.

Pressure data are acquired by an independent electronically-scanned pressure (ESP) system which, in turn, transfers the data to the ESCORT II system. The ESP system in this facility has the capability to monitor 124 pressure channels simultaneously. All pressure ports use 5 psi differential transducers with a quoted accuracy of ± 0.1 percent of full scale. In order to mate the test model pressure ports to the ESP system, 1/16 in. O.D. steel tubing leads must be used.

The instrumentation also has the provision to monitor 36 type 'E' Chromel-Constantan thermocouples for various facility and test hardware temperature measurements. One thermocouple is reserved for measurement of the facility total temperature and is located in the settling chamber. Therefore, 35 thermocouples can be used for the model hardware. Standard size type 'E' male connectors should be used in order to properly interface with the facility instrumentation.

The ESCORT II data system also can acquire analog data. Currently, there are 54 analog data channels available. This count does include the temperature data since the data system considers the thermocouple channels as analog input. However, only the actual thermocouple channels being used count as analog data input. The remaining analog data channels can be used for other types of instrumentation such as potentiometers or other analog positioning sensing devices.

With the advent of digital technology, digital encoders are being used more frequently for probe position sensing. The ESCORT II data system does have a limited capability to handle these types of data input. At this time, no more than four encoders can be used at one time for position sensing applications.

Facility Instrumentation Hardware

The previous section discussed instrumentation that is generally available for a test program while this section details specific instrumentation hardware already incorporated into the Internal Fluid Mechanics Facility.

The settling chamber has both a pressure and temperature probe which are used to monitor the facility stagnation conditions. These probes face upstream and are attached to the coarse one-half mesh screen near the facility axial centerline. Therefore, the

stagnation conditions do not take into account the pressure losses due to the screen-honeycomb combination. These losses are quantified and presented in the Facility Flow Quality section of this report.

A static pressure tap is located in the exhaust region of the facility and is used to monitor the pressure in the sub-atmospheric portion of the facility. The exhaust pressure, along with the plenum stagnation pressure, can be used to set the facility operating conditions. There is no provision to monitor a reference upstream static pressure in the test region of the facility unless the 30 in. boundary layer duct is used as a part of the experimental hardware. Alternatively, the experimental hardware could be designed to include a reference static pressure tap to monitor the facility operating conditions.

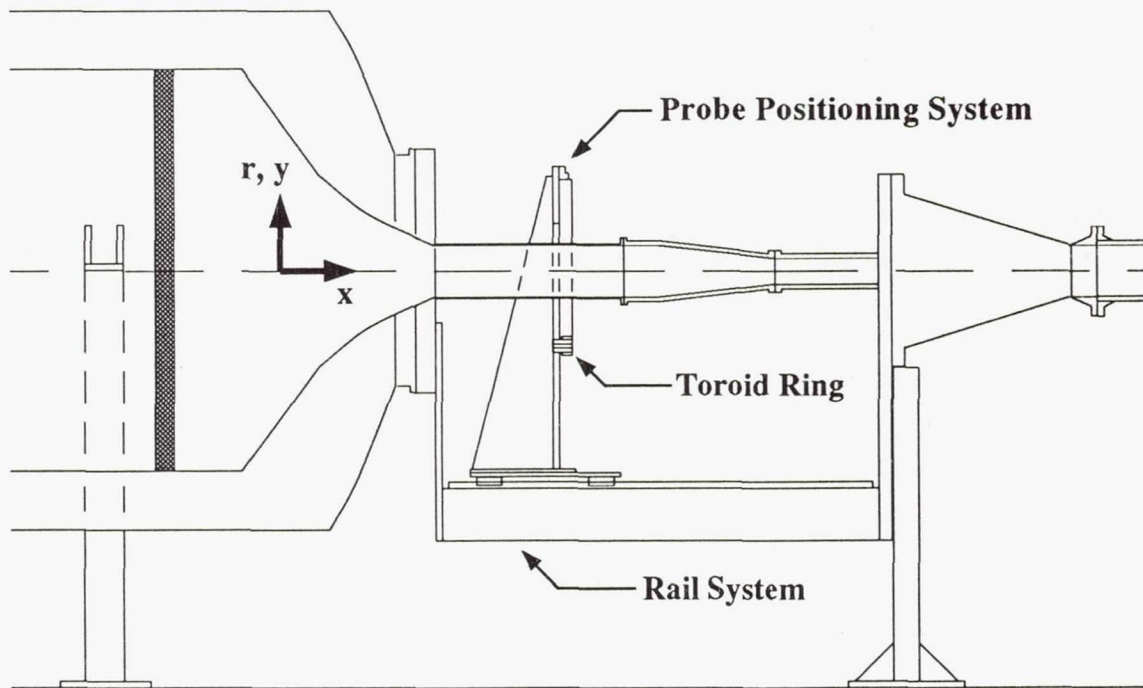

Figure 5. Schematic of probe positioning system.

The mass flow plug which is currently installed in the exhaust region of the facility uses a potentiometer to sense its position. If this system were carefully calibrated, it also could provide a means of determining the facility operating condition. However, previous attempts to employ this method were unsuccessful due to a non linear behavior of the system. Use of the facility pressures to set operating conditions was more reliable.

Aerodynamic measurement instrumentation such as pitot pressure and hot-wire probes can be incorporated into a facility probe positioning system in order to conduct flowfield

surveys of the test hardware. A sketch of the probe positioning system as it is installed in the facility is shown in Fig. 5.

In the current facility configuration, the probe positioning system is mounted on a rail system which allows probe movement in the test region along the facility centerline (x-axis). Since the rail system is designed to traverse the length of the current test hardware only, it must be redesigned if a longer model is installed in the facility. A toroid ring assembly is incorporated into the probe positioning system and is mounted concentrically about the facility centerline. The toroid ring is used to give the probe positioning system a cylindrical coordinate (r,θ) movement capability. A linear traversing mechanism is attached to the ring and is used for cartesian coordinate (y,z) positioning when the toroid ring is locked in place to fix the probe at the 90 degree radial location.

Facility Operating Conditions

A typical facility operating curve of freestream operating Mach number versus facility mass flow rate is shown in Fig. 6. This curve specifically applies to the existing test hardware which uses the 8.04 in. diameter circular upstream boundary layer duct and the downstream mass flow control assembly. The freestream Mach numbers and mass flow rates were calculated at an axial distance 26 in. downstream of the plenum contraction section. Since this curve was generated only as an aid to assess the overall facility performance, the mass flow rates were calculated by using a constant freestream velocity which neglects the mass flow deficit due to the boundary layer growth.

In this case, the facility was not connected to the high pressure supply system so ambient air was used as the supply pressure for the facility. Use of the facility in this mode does not allow for the control of the facility total pressure. Therefore, for a constant Mach number, only one mass flow rate is available as shown in Fig. 6.

The laboratory high pressure supply system allows for the control of the facility plenum pressure. When the facility is used in this mode, a variety of mass flow rates can be chosen for a constant Mach number operating condition. In addition to total pressures above atmospheric pressure, the laboratory supply system has the capability to provide sub-atmospheric facility total pressures. If an experiment is designed to use an 8.04 in. circular inlet duct diameter, the maximum facility flow rate using the high pressure supply would be approximately 45 lb_m/s.

Facility Flow Quality

As with the mass flow data, the facility flow quality is documented by using the upstream boundary layer duct of the existing facility hardware. Aerodynamic measurements in the form of total pressure and duct wall static pressure measurements were made at an axial location equivalent to 3.2 duct diameters (26 in.) downstream of the plenum contraction section exit. In addition to the pressure measurements, hot

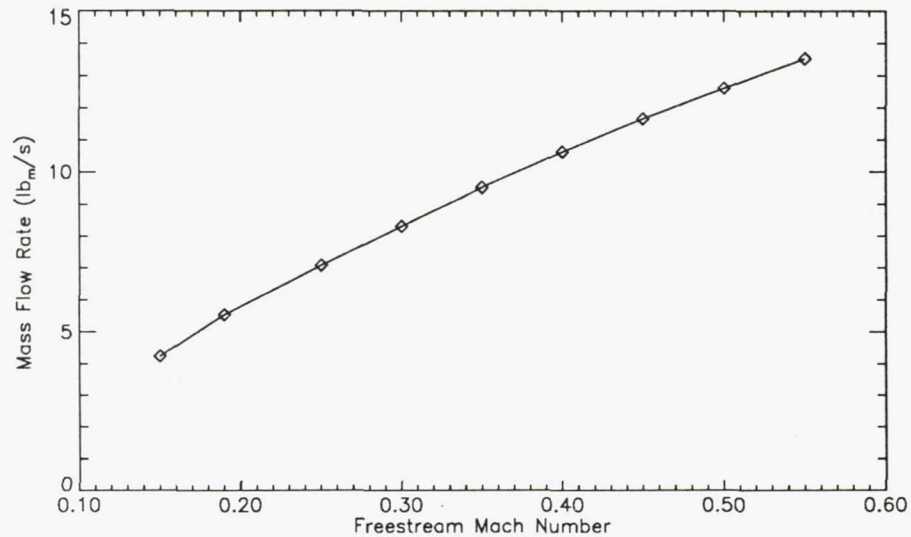

Figure 6. Typical facility operating curve using ambient supply air.

Table 1. Facility Calibration Conditions

Nominal Mach Number	Actual Mach Number	Freestream Velocity (ft/s)	Plenum Pressure (psia)	Flow Conditioning Pressure Loss ($\Delta P_o/P_o$)
0.2	0.196	221.07	14.44	0.0011
0.3	0.298	334.45	14.44	0.0012
0.4	0.399	444.74	14.44	0.0022
0.5	0.499	551.43	14.44	0.0032

wire measurements were made by Reichert [3] to quantify the facility freestream axial turbulence.

The test conditions used to document the facility flow quality are tabulated in Table 1. Also shown in the Table are the total pressure losses associated with the flow conditioning devices in the plenum. These losses show a consistent behavior except for the nominal Mach number case of 0.20. This discrepancy is attributed to the fact that the total pressure loss at this condition becomes minimal and is at the same order of magnitude as the accuracy of the transducer used to monitor this pressure loss. If a more accurate pressure transducer was used, the observed total pressure loss would be consistent with the other data.

Duct Mach number profiles are shown in Fig. 7 for facility nominal operating Mach numbers of 0.2, 0.3, 0.4 and 0.5. The local Mach numbers were obtained by using

isentropic relations that relate the local static pressure and total pressure measurements to a local Mach number. This approach assumes the the static pressure is constant at this axial plane and is equal to the measured wall static pressure. Two wall static pressure taps circumferentially spaced 180 degrees apart showed that no substantial static pressure gradient existed at this measurement plane. The results indicate that the plenum contraction and downstream duct combination produces a well-behaved flowfield with a uniform core and wall boundary layers approaching 10 percent of the duct radius.

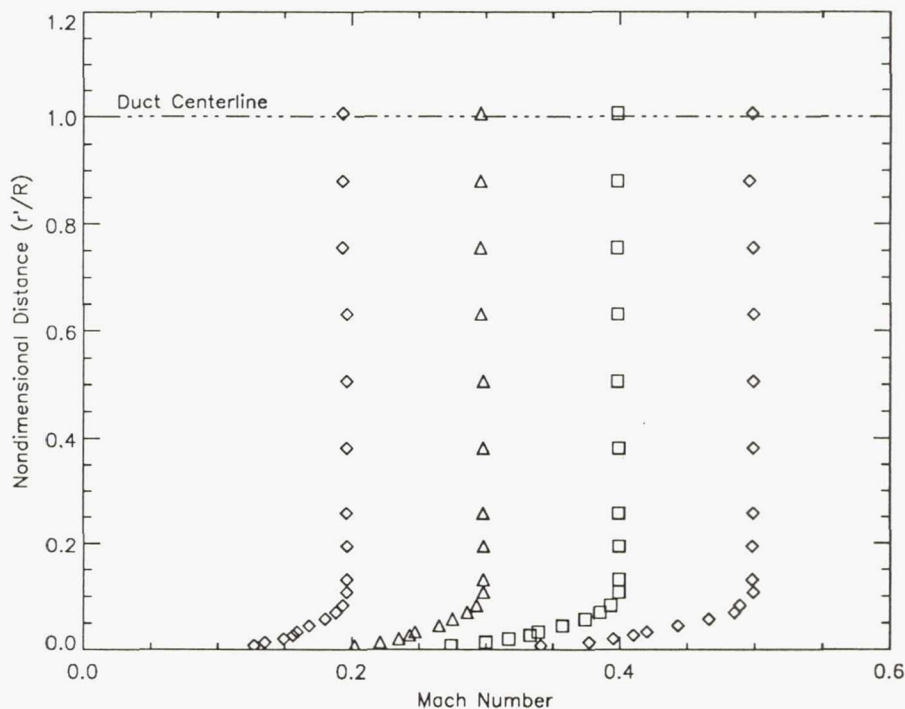

Figure 7. Experimentally-measured boundary layer duct Mach number profiles.

At each operating condition, the wall boundary layers were analyzed by using a turbulent boundary layer wall-wake correlation [4]. The correlation results, along with the boundary layer data presented in Figs. 8-11 show that at most conditions, the boundary layers are well behaved and match a turbulent boundary layer profile. However, there seems to be some scatter in the Mach 0.5 data since the wall-wake analysis does not match the data as well as the lower Mach number conditions.

Reichert [3] investigated the freestream axial turbulence levels in the facility using the same upstream boundary layer duct. Over a range of facility operating conditions from a nominal Mach number of 0.3 to 0.5, the measured turbulence intensity varied from 0.64 to 0.69 percent of the average freestream velocity.

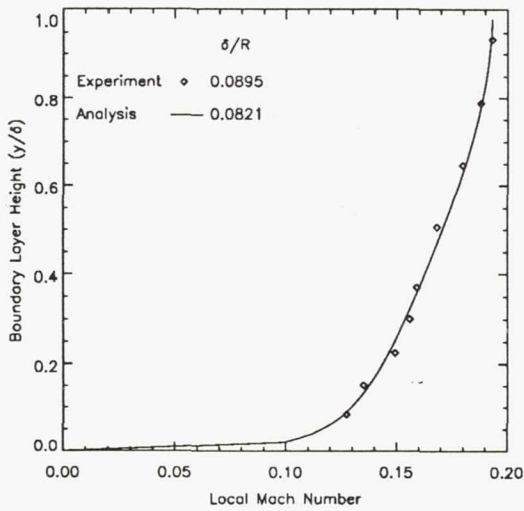

Figure 8. Facility boundary layer profile, $M_\infty = 0.2$.

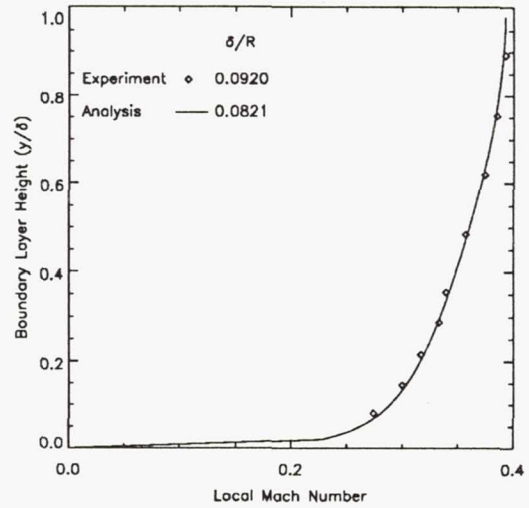

Figure 10. Facility boundary layer profile, $M_\infty = 0.4$.

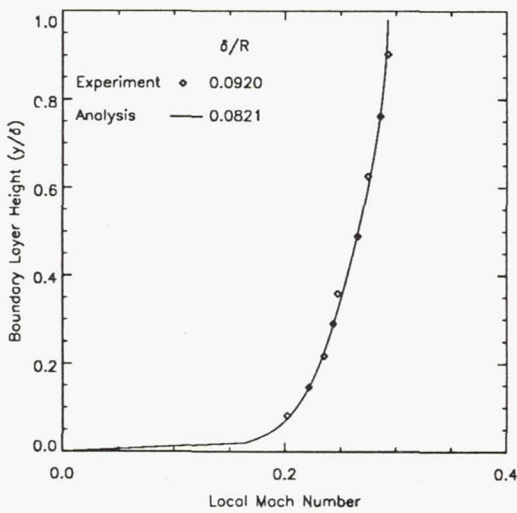

Figure 9. Facility boundary layer profile, $M_\infty = 0.3$.

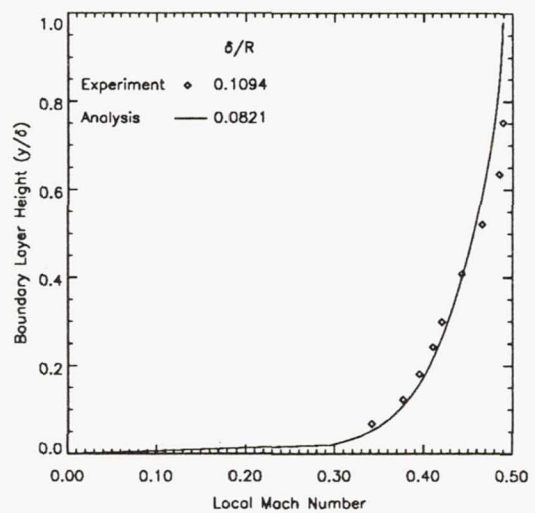

Figure 11. Facility boundary layer profile, $M_\infty = 0.5$.

Summary

An experimental facility specifically designed to investigate internal fluid duct flows has been built at the NASA Lewis Research Center. It is built in a modular fashion so that a variety of internal flow test hardware can be installed in the facility with minimal facility reconfiguration. The facility and test hardware interfaces are discussed, along

with design constraints of future test hardware. The plenum flow conditioning approach is also detailed. Available instrumentation and data acquisition capabilities are discussed.

The incoming flow quality has been documented over the current facility operating range. The incoming flow produces well behaved turbulent boundary layers with a uniform core. For the calibration duct used, the boundary layers approached 10 percent of the duct radius. Freestream turbulence levels at the various operating conditions varied from 0.64 to 0.69 percent of the average freestream velocity.

Appendix A. Aerodynamic Design of Facility Flow Conditioning

A schematic of the flow conditioning configuration installed in the plenum of the Internal Fluid Mechanics Facility is shown in Fig. 12. The flow conditioners can be divided into three categories: (1) the flow spreader cone, (2) the screens and honeycomb, and (3) the contraction section.

Since the plenum is an axisymmetric design with the supply air entrance located in line with the flow axis of the facility, there is the possibility that the incoming air flow will not properly diffuse and fill the entire plenum chamber. This could adversely affect the facility flow quality if not corrected. In anticipation of this potential problem, a flow spreading device is designed whose function is to adequately diffuse the incoming supply air. The device used is a perforated cone assembly suggested by Pope and Goin [1]. In this facility, the flow spreader cone is designed to have an included angle of 90 degrees and 40 percent open area. The perforation geometry uses an array of 1/4 in. diameter circular holes to produce the necessary open area.

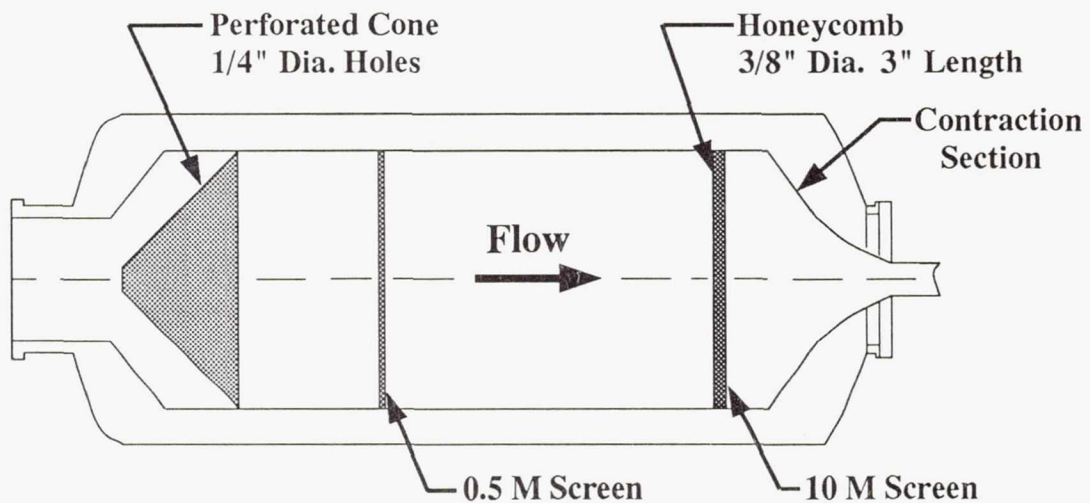

Figure 12. Schematic of facility aerodynamic flow conditioning.

The next set of flow conditioners are the screens and honeycomb. These devices are used to lower the freestream turbulence and flow angularity in the facility. Traditional flow conditioning approaches typically use a series of fine mesh screens spaced a discrete distance apart, and sometimes these screens are preceded by a honeycomb assembly. The configuration used for this facility is viewed as an unconventional arrangement because it uses a very coarse mesh upstream screen followed by a honeycomb/single fine mesh screen assembly. The design criteria for the upstream screen and screen/honeycomb combination used in this facility will be reported subsequently. Mr. Richard R. Burley

of the NASA Lewis Research Center conveyed these design criteria to the authors via private communication.

Various flow conditioning techniques were investigated by Burley and Harrington [2] including a configuration similar to what was used for this facility. Although this configuration was not the best in reducing turbulence, it was chosen because of two important factors. The first factor is ease of installation. In the traditional configurations, isolated fine mesh screens are spaced a discrete distance apart which requires an elaborate tensioning and mounting assembly to be fabricated for the screens. These assemblies tend to be quite costly and often are difficult to integrate into an existing plenum design. In the case of the configuration chosen for this facility, the single fine mesh screen is attached directly to the honeycomb structure which eliminates the need for additional structural support devices and screen tensioning hardware.

The second factor to consider is the flow conditioning approach as a whole. In addition to using the screens and honeycomb to reduce turbulence, a judicious choice of contraction section geometry will also aid in the turbulence reduction process. In this facility, the contraction section area ratio is 59. With a contraction ratio this large, the additional increment in turbulence reduction gained by using an elaborate honeycomb and multiple screen flow conditioning design would be small compared to the additional costs incurred by integrating this complicated design into the facility.

The first screen in the plenum is designed to have a very coarse grid. The purpose of this screen is to reduce the mean flow nonuniformities after the flow exits the perforated cone by enhancing the flow mixing process. The aerodynamic design criteria for this screen is to have a Reynolds number based on the mesh spacing greater than 10^4 and at least 60 percent open area. In order to satisfy these requirements, a one-half mesh screen was chosen (1 wire per 2 in.) with 7/16 in. diameter rods.

In order to allow the enhanced mixing caused by the coarse screen to decay, Burley suggests that the honeycomb/screen combination be located between 20 and 40 coarse mesh lengths downstream. For this facility, 40 mesh lengths was chosen because this distance locates the honeycomb/screen combination closest to the plenum contraction section. This resulted in a flow conditioner spacing of 80 in.

For the downstream honeycomb/screen combination, the honeycomb is used to reduce the transverse components of turbulence, while the fine mesh screen reduces the axial turbulence levels. Several design criteria must be considered in order to integrate the two flow conditioners. In particular, the ratio of the honeycomb cell length dimension (L) to cell size dimension (D) must fall between 6 and 12. In addition to this, the ratio of the fine screen mesh size to the honeycomb mesh size must be between 3 and 4. Also, as with the coarse mesh upstream screen, the fine mesh screen requires an open area of at least 60 percent.

The honeycomb chosen to be used in this facility has a hexagonal-shaped cell cross-section, so the cell size dimension is defined to be the distance between two opposing

flats of the hexagon. An effective mesh spacing for the honeycomb can also be defined as the number of these flats parallel to each other in a one inch span.

Taking the design criteria into consideration, the following components were chosen for the facility downstream flow conditioning: (1) a honeycomb with 3/8 in. cell size and a cell length of 3 in., and (2) a 10 mesh downstream screen with 60 percent open area. For the honeycomb this yields an L/D ratio of 8 which is in the range of the prescribed design limits. Based on the honeycomb cell size, the effective honeycomb mesh size is 2.67. This results in a screen mesh to honeycomb mesh ratio of 3.75, again within Burley's suggested design limits.

The final flow conditioning component is the plenum contraction section which directs the flow from the plenum into the test region. The large contraction ratio of the facility allows for a simplified design of the contraction section geometry and also facilitates the ease of manufacture. The inlet and exit diameter of the contraction section are 61.90 in. and 8.04 in., respectively. The total length of the contraction section is approximately 30 in.

The contraction section design is divided into two segments. The upstream segment has a linear cross section which translates into a conical spool section for the actual facility hardware because of the axisymmetric facility design. The downstream segment geometry is more complicated; a cubic polynomial describes this cross-section geometry. The critical design constraint is that the slope of each contour be equal at the juncture of each segment and at the exit of the contraction section/boundary layer duct interface.

The contraction section geometry was analyzed by using an axisymmetric parabolized Navier-Stokes computer code before being fabricated. The analysis indicated that no flow separation would occur in the contraction section, and that it would produce a uniform flowfield in the test section's boundary layer duct with boundary layers approximately 10 percent of the duct radius. The facility flow quality measurements presented earlier show the same results, i.e., there was no evidence of upstream flow separation, and the resulting duct boundary layers approached 10 percent of the duct radius.

Appendix B. Description of Model Hardware/Facility Interfaces

This Appendix discusses the interfaces needed to properly install a test model in the Internal Fluid Mechanics Facility. This discussion is divided into two parts: the first part details the hardware needed to interface with the plenum contraction section, while the second section discusses the facility exhaust system interfaces.

Test Section Inlet Interfaces

Currently, there are two ways to connect the model hardware to the upstream portion of the facility. The hardware can be bolted directly to the exit of the contraction section, or the 30 in. circular duct can be used as an intermediate interface. In both cases, the model interface hardware must have a circular cross section with an 8.04 in. nominal I.D. As mentioned earlier, the 30 in. circular duct is useful in applications that require a boundary layer to be ingested into the test model.

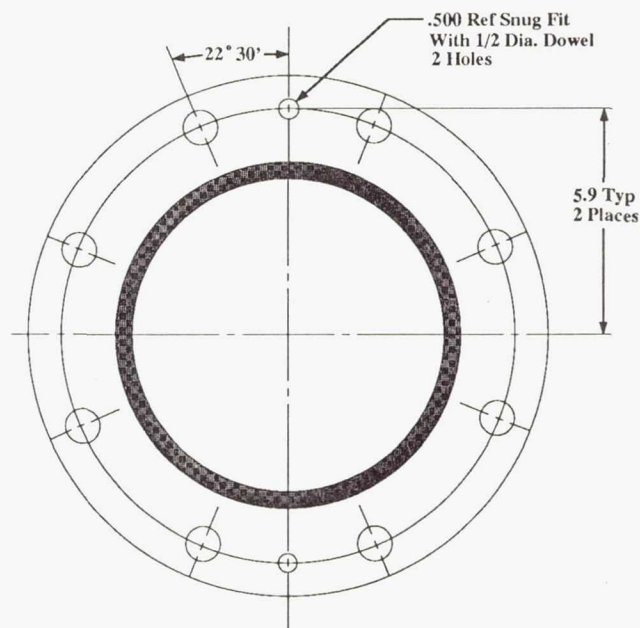

Standard Slip-On Flange 8 in., 150 lb

Figure 13. Schematic of connection to facility contraction section. Linear dimensions are given in inches.

A schematic of the flange that is at the exit of the contraction section is shown in Fig. 13. As annotated in the Figure, this connection uses a standard 8 in., 150 lb flange with the addition of holes for locating dowel pins. This is the connection that must be considered when interfacing the test hardware directly to the plenum contraction section. At the contraction section/test section interface, there must be a provision to properly seal the connection so no airflow leakage occurs. Therefore, a gasket or o-ring must be

used at this interface. If an o-ring is used to form the seal, a groove must be cut into the 8 in. test hardware flange. A typical o-ring groove design that has been used successfully in this facility is shown in Fig. 14.

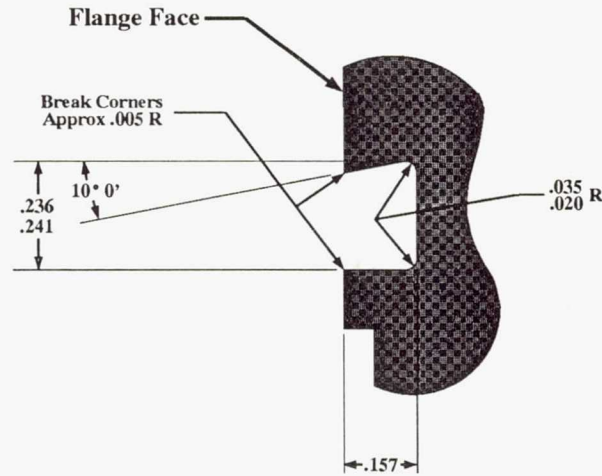

Figure 14. Schematic of o-ring groove design used for flange interfaces. Linear dimensions are given in inches.

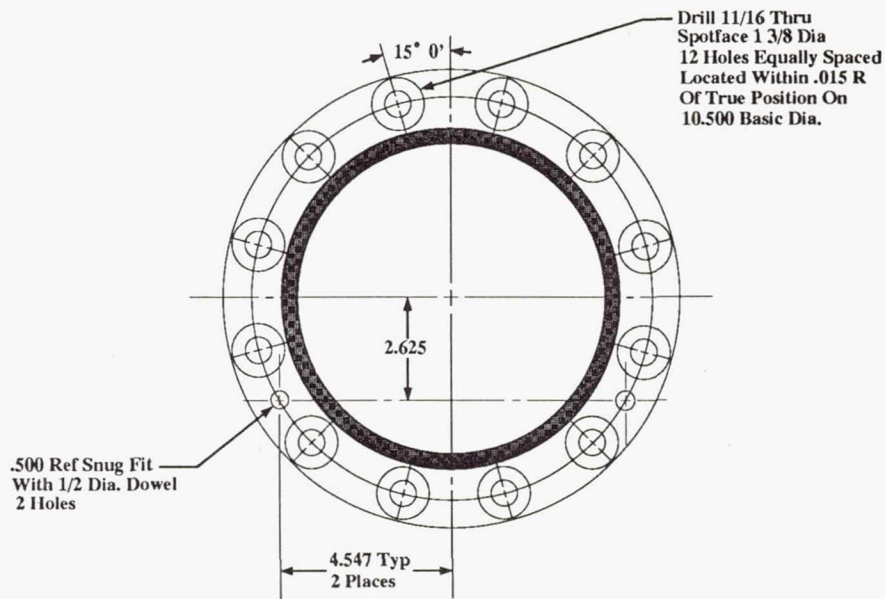

Figure 15. Schematic of connection to 30 in. duct. Linear dimensions are given in inches.

When using the 30 in. duct as an intermediate interface, the connection shown in Fig. 15 is used to interface to the model hardware. This flange is not a standard, so the bolt pattern shown in the Figure must be used. Also shown are the holes for the locating dowel pins. In this case, the 30 in. duct has an o-ring groove milled into the flange, so no o-ring groove would be needed for the test hardware interface flange.

Test Section Exit Interfaces

As with the test section/plenum interface, there are two ways of mating the test hardware to the exhaust region of the facility. The simplest case is when the exit geometry of the test hardware has a circular cross section with the same diameter as the exhaust pipe/mass flow plug assembly. In this case, the transition spool piece and mating flange shown in Fig. 4 are removed so that the test hardware connects directly to the exhaust pipe/mass flow plug assembly. When this interface approach is used, the test hardware must be lengthened somewhat to accommodate the missing transition spool piece and mating flange. Note that the exit diameter of the facility piping is 10 in., not the inlet diameter of 8 in. The mating flange for this connection is shown in Fig. 16. It is a standard 10 in. weld neck flange. Instead of using a standard sealing gasket for this flange, an o-ring groove may be milled in to the gasket surface of the flange for better sealing characteristics.

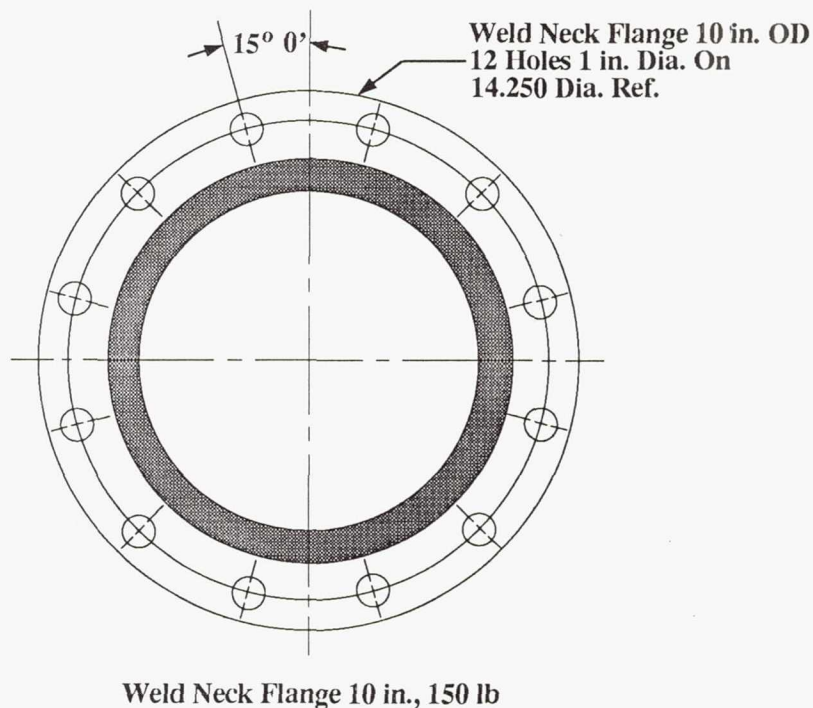

Figure 16. Schematic of connection to facility exhaust duct. Linear dimensions are given in inches.

If the experimental hardware does not have a 10 in. circular cross-sectional geometry at its exit plane, then the exhaust transition spool piece and mating flange can be used as a test hardware/facility interface. In this case, the mating flange opening is customized to match the experimental hardware exit geometry. A schematic of the mating flange used for the transition duct experiment is shown in Fig. 17. This particular mating flange has a superelliptic cutout that allows the transition duct hardware to be connected to

the facility exhaust region. New mating flanges with hardware specific cutouts can be designed using the general specifications shown in Fig. 17.

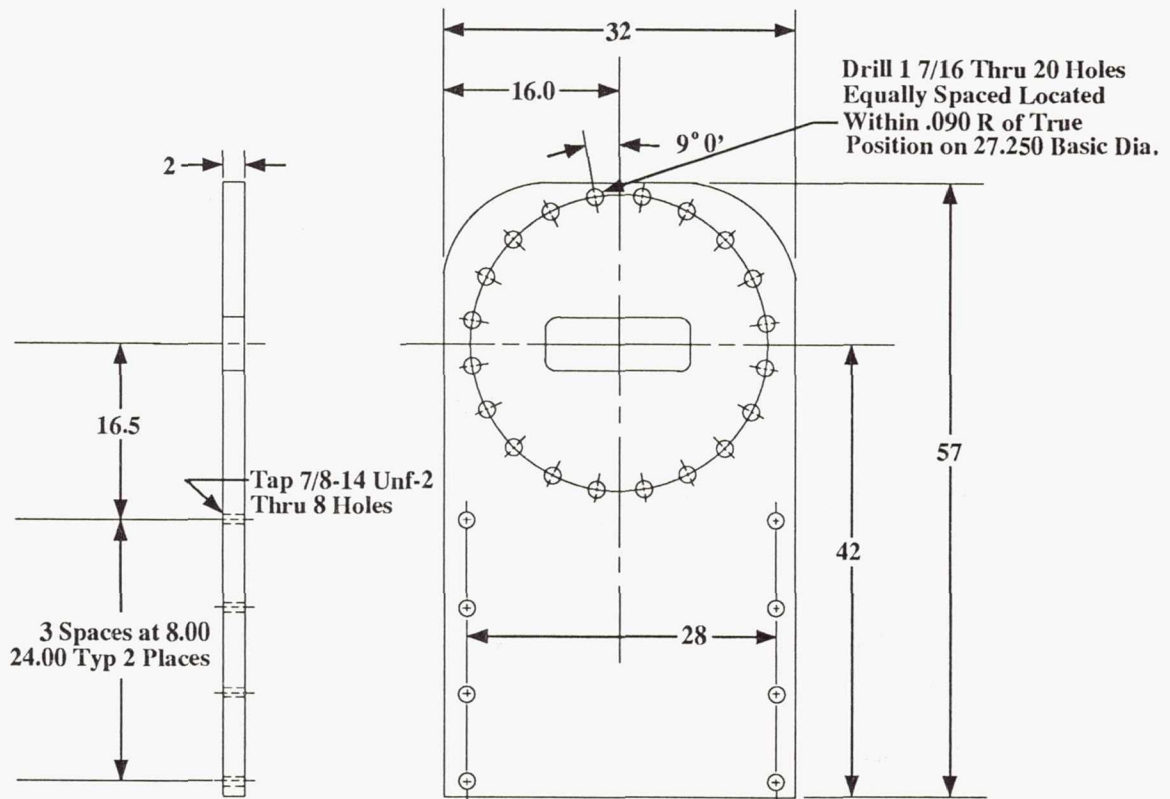
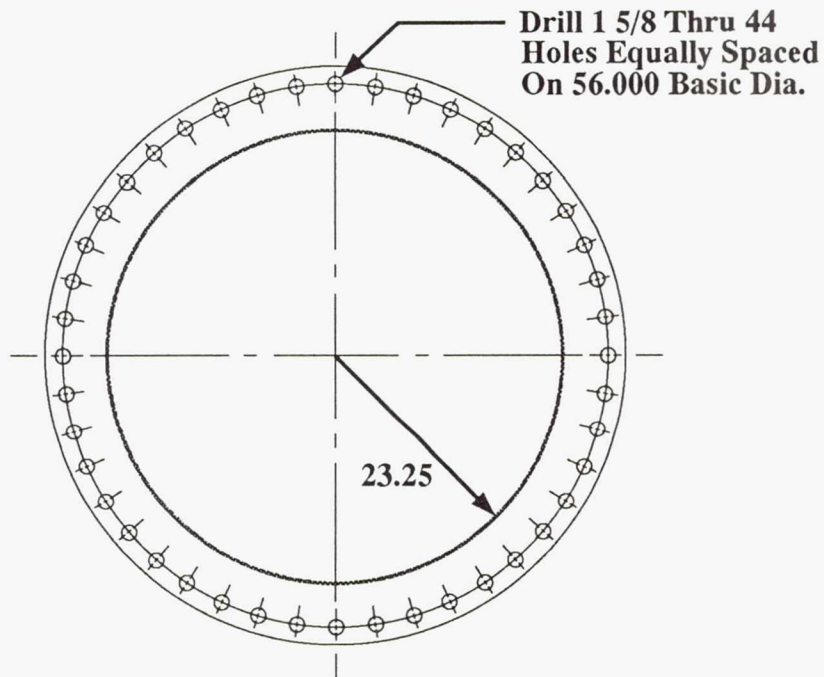

Figure 17. Schematic of mating flange used for the transition duct experiment. Linear dimensions are given in inches.

Fig. 18 shows a schematic of the 48 in. exhaust flange which is used as an interface between the Internal Fluid Mechanics Facility and the laboratory exhaust system. As mentioned previously, modified flanges with test specific cutouts can be used if necessary. For example, if a duct was tested whose exit plane was not aligned with the facility centerline, a modified flange could be designed with an off-centerline cutout to match the test hardware. The only limitation is that the cutout must lie within the 23.25 in. radius shown in the Figure.



**Raised Face Steel Blank Flange
48 in., 150 lb. Alter As Shown**

Figure 18. Schematic of facility exhaust flange. Dimensions are given in inches.

References

- [1] Pope, A. and Goin, K.L., *High Speed Wind Tunnel Testing*. Malabar, FL: Robert E. Krieger Publishing Company, 1978.
- [2] Burley, R.R. and Harrington, D.E., "Experimental Evaluation of Honeycomb/Screen Configurations and Short Contraction Section for NASA Lewis Research Center's Altitude Wind Tunnel." NASA TP 2692, 1987.
- [3] Reichert, B.A., *A Study of High Speed Flows in an Aircraft Transition Duct*. PhD thesis, Iowa State University, Ames, IA, 1991. (Also NASA TM 104449).
- [4] Sun, C.C. and Childs, M.E., "Wall-Wake Velocity Profile for Compressible Nonadiabatic Flows," *AIAA J.*, vol. 14, pp. 820-822, June 1976.

REPORT DOCUMENTATION PAGE

Form Approved
OMB No. 0704-0188

Public reporting burden for this collection of information is estimated to average 1 hour per response, including the time for reviewing instructions, searching existing data sources, gathering and maintaining the data needed, and completing and reviewing the collection of information. Send comments regarding this burden estimate or any other aspect of this collection of information, including suggestions for reducing this burden, to Washington Headquarters Services, Directorate for Information Operations and Reports, 1215 Jefferson Davis Highway, Suite 1204, Arlington, VA 22202-4302, and to the Office of Management and Budget, Paperwork Reduction Project (0704-0188), Washington, DC 20503.

1. AGENCY USE ONLY (Leave blank)	2. REPORT DATE September 1991	3. REPORT TYPE AND DATES COVERED Technical Memorandum	
4. TITLE AND SUBTITLE The NASA Lewis Research Center Internal Fluid Mechanics Facility		5. FUNDING NUMBERS WU - 505 - 62 - 52	
6. AUTHOR(S) A.R. Porro, W.R. Hingst, C.A. Wasserbauer, and T.B. Andrews		8. PERFORMING ORGANIZATION REPORT NUMBER E - 6487	
7. PERFORMING ORGANIZATION NAME(S) AND ADDRESS(ES) National Aeronautics and Space Administration Lewis Research Center Cleveland, Ohio 44135 - 3191		10. SPONSORING/MONITORING AGENCY REPORT NUMBER NASA TM - 105187	
9. SPONSORING/MONITORING AGENCY NAMES(S) AND ADDRESS(ES) National Aeronautics and Space Administration Washington, D.C. 20546 - 0001		11. SUPPLEMENTARY NOTES Responsible person, A.R. Porro, (216) 433 - 5921.	
12a. DISTRIBUTION/AVAILABILITY STATEMENT Unclassified - Unlimited Subject Category 09		12b. DISTRIBUTION CODE	
13. ABSTRACT (Maximum 200 words) An experimental facility specifically designed to investigate internal fluid duct flows has been built at the NASA Lewis Research Center. It is built in a modular fashion so that a variety of internal flow test hardware can be installed in the facility with minimal facility reconfiguration. The facility and test hardware interfaces are discussed, along with design constraints of future test hardware. The plenum flow conditioning approach is also detailed. Available instrumentation and data acquisition capabilities are discussed. The incoming flow quality has been documented over the current facility operating range. The incoming flow produces well behaved turbulent boundary layers with a uniform core. For the calibration duct used, the boundary layers approached 10 percent of the duct radius. Freestream turbulence levels at the various operating conditions varied from 0.64 to 0.69 percent of the average freestream velocity.			
14. SUBJECT TERMS Wind tunnels; Fluid mechanics facility		15. NUMBER OF PAGES 22	16. PRICE CODE A03
17. SECURITY CLASSIFICATION OF REPORT Unclassified	18. SECURITY CLASSIFICATION OF THIS PAGE Unclassified	19. SECURITY CLASSIFICATION OF ABSTRACT Unclassified	20. LIMITATION OF ABSTRACT