

9/12/91
E6479

NASA Technical Memorandum 105183

Measurement Techniques for Cryogenic Ka-Band Microstrip Antennas

M.A. Richard
Case Western Reserve University
Cleveland, Ohio

K.B. Bhasin
Lewis Research Center
Cleveland, Ohio

C. Gilbert and S. Metzler
Ball Communications Systems Division
Broomfield, Colorado

and

P.C. Claspy
Case Western Reserve University
Cleveland, Ohio

Prepared for the
13th Annual Meeting and Symposium of the Antenna
Measurement Techniques Association
sponsored by the National Institute of Standards and Technology
Boulder, Colorado, October 7-11, 1991

NASA

MEASUREMENT TECHNIQUES FOR CRYOGENIC KA-BAND MICROSTRIP ANTENNAS

M.A. Richard
Case Western Reserve University
Department of Electrical Engineering
Cleveland, Ohio 44106

K.B. Bhasin
National Aeronautics and Space Administration
Lewis Research Center
Cleveland, Ohio 44135

C. Gilbert and S. Metzler
Ball Communications Systems Division
Broomfield, Colorado 80020

P.C. Claspy
Case Western Reserve University
Department of Electrical Engineering
Cleveland, Ohio 44106

ABSTRACT

The measurement of cryogenic antennas poses unique logistical problems since the antenna under test must be embedded in the cooling chamber. In this paper, a method of measuring the performance of cryogenic microstrip antennas using a closed cycle gas-cooled refrigerator in a far field range is described. Antenna patterns showing the performance of gold and superconducting Ka-band microstrip antennas at various temperatures are presented.

1. INTRODUCTION

Printed circuit antennas have been the focus of much research in recent years as candidates for applications such as satellites where weight and volume are a premium [1]. In theory, many-element microstrip arrays could rival the gain of traditional parabolic dishes. However, microstrip antennas have high ohmic losses which act to limit the maximum obtainable gain. This problem is compounded at millimeter wave frequencies since the surface resistance of metals increases with $f^{1/2}$, causing microstrip transmission lines to be much more lossy.

It is well known that ohmic losses may be reduced significantly by cooling the circuit to cryogenic temperatures. Gold has a resistance temperature coefficient of approximately $10 \text{ n}\Omega \text{ cm/K}$. Computer simulations show that a reduction in temperature from 300 K to 77 K translates to 10 dB/m less loss at 30 GHz for a microstrip line on 0.25 mm alumina. The use of cryogenics has the additional benefit of reducing the noise figure of the system, which is critical for radiometric antennas. Recently, much attention has been given to the use of high temperature superconductors (HTS) as a solution to the problem of gain limitation in many-element microstrip array antennas [2,3]. According to [3], an HTS 100 element linear array at 35 GHz could experience a gain increase of 8 to 10 dB over an identical copper array. Measurements of 35 GHz HTS ring resonators have shown an improvement in microstrip line attenuation of 10 dB over identical gold circuits when both are at 77 K. [4]

In a practical sense, measuring the performance of antennas at cryogenic temperatures is quite difficult. If the antenna is to be cooled in a cryogen such as liquid nitrogen or liquid helium, a radio-transparent dewar must be used. In general such an arrangement allows performance measurements only at two temperatures: room temperature and the boiling point of the cryogen. This type of cryostat has been used by [5] to measure electrically small superconducting arrays at 650 MHz and by [6] to measure a 500 MHz HTS dipole. A gas refrigerator, on the other hand, has the advantage that the temperature can be set to any value within its range. However, a vacuum must be maintained, which necessitates the use of some type of radio-transparent vacuum jacket.

In this paper, we discuss the design of a temperature-controlled cryostat which has been used to successfully test planar superconducting microstrip arrays at 30 GHz. To our knowledge this is the first reported use of a gas refrigerator for cryogenic antenna measurements.

2. DESIGN

The cryostat used is based upon a CTI-Cryogenics compressor and cold head. The unit is a closed-cycle helium refrigerator. A Lakeshore Cryogenics temperature controller controls the current through a heater element to provide temperature control over the system. The two-stage cold finger is enclosed by a stainless steel tube, capped with a lid machined from high-density polyethylene (HDPE) as shown in Fig. 1. HDPE was chosen because of its low relative permittivity (2.34) [7] and loss tangent and because it is inexpensive in comparison to other polymers such as teflon. The lid is spherical with an inner radius of 12.7 cm and thickness of .508 cm. A hermetically sealed coaxial feedthru (two back-to-back "K" sparkplug launchers) passes the RF into the vacuum chamber. Semirigid coaxial cable connects the feedthru to the antenna test fixture.

The antennas used are 4 element microstrip arrays with a resonance at 31.7 GHz. The antennas were patterned onto their respective substrates, magnesium oxide (MgO) and lanthanum aluminate (LaAl_2O_3), and assembled into a brass test fixture (Fig. 2). A 50Ω gold microstrip feed line patterned on an alumina substrate separates the coax-to-microstrip transition (Wiltron V-connector) from the antenna. The test fixture was made as thin as practically possible to reduce the thermal loading of the cryostat, thereby hastening the cool-down and warmup times involved. Wire bonds connect the feed line to the antenna. To test the antennas, each test fixture was in turn mounted at the second stage of a 2-stage closed-cycle helium refrigerator. A high-density polyethylene (HDPE) cap serves as both a vacuum jacket and a radome. S-parameter (S_{11}) measurements using an HP 8510B were done by calibrating to the coaxial connector inside the cryostat while at room temperature. The entire cryostat was mounted on a plexiglass stand, which in turn was fastened to the rotating pedestal of a far-field antenna range for pattern measurements in the receive mode (Fig. 3).

3. ANTENNA MEASUREMENTS

This setup was used to measure H-plane patterns of the aforementioned Ka-band microstrip arrays. The arrays were fabricated with high-temperature superconductors (HTS) and, for comparison purposes, with evaporated gold. The antennas were measured at 30 K, 70 K and room temperature (295 K). In addition, the array patterns of the gold antennas were measured with and without the HDPE lid to judge the effect of the radome. The measured patterns are shown in Fig. 2. Comparison of the patterns with and without the lid show the H-plane patterns to be essentially unchanged, except for a 3-dB amplitude decrease when the lid is removed. This is most likely a result of the lid acting as a dielectric lens, thereby weakly focusing the radiation. The thickness of the HDPE lid was chosen arbitrarily, and at the resonant frequency of the antennas is 1.22 dielectric wavelengths. The gold antenna patterns show a 3 dB increase in received power as the temperature is lowered from 295 K to 30 K. The HTS arrays show a distinct difference in pattern below and above the critical temperature (T_c), with the received power increasing by more than 10 dB below T_c .

4. CONCLUSIONS

A specially designed cryogenic unit has been developed for the measurement of microstrip antennas at temperature down to 25 K. The use of the unit was demonstrated by measuring far-field patterns and the reflection coefficients of superconducting and gold Ka-band microstrip arrays. H-plane measurements show no substantial effects resulting from the presence of the HDPE radome.

ACKNOWLEDGMENT

The authors would like to thank Mr. Ed Smith for his help in the measurement of these antennas, and Dr. R.Q. Lee for his constructive suggestions. One of the authors (M.A. Richard)

acknowledges support through a NASA Space Grant / Ohio Aerospace Institute Doctoral Fellowship.

5. REFERENCES

1. Ely Levine, Gabi Malamud, Shmuel Shtrikman, and David Treves, "A Study of Microstrip Array Antennas with the Feed Network," *IEEE Trans. Antennas and Propagat.*, vol. AP-37, no. 4, pp. 426-434, Apr. 1989.
2. R.C. Hansen, "Superconducting Antennas," *IEEE Trans. on Aerospace and Electronic Systems*, vol. 26, no. 2, pp. 345-354, March 1990.
3. Robert J. Dinger, "Some Potential Antenna Applications of High Temperature Superconductors," *Journal of Superconductivity*, vol. 3, no. 3, pp. 287-296, 1990.
4. C.M. Chorey, K.B. Bhasin, J.D. Warner, J.Y. Joesfowicz, D.B. Rensch, and C.W. Nieh, "An Experimental Study of High Tc Superconducting Microstrip Transmission Lines at 35 GHz and the Effect of Film Morphology," *IEEE Trans. on Magnetics*, pp. March 1991.
5. G.B. Walker, Clovis R. Haden, and O.G. Ramer, " *IEEE Trans. Antennas and Propagat.*, vol. AP-25, no. 6, pp. 885-887, Nov. 1977.
6. S.K. Khamas, M.J. Mehler, T.S. Maclean, C.E. Gough, "High Tc Superconducting Short Dipole Antenna," *Electronics Letters*, vol.24, no. 8, pp. 460-461, April 1988.
7. Karlheinz Seeger, "Microwave Measurement of the Dielectric Constant of High-Density Polyethylene," *IEEE Trans. Microwave Theory and Tech.*, vol. 39, no. 2, pp. 352-354, Feb. 1991.

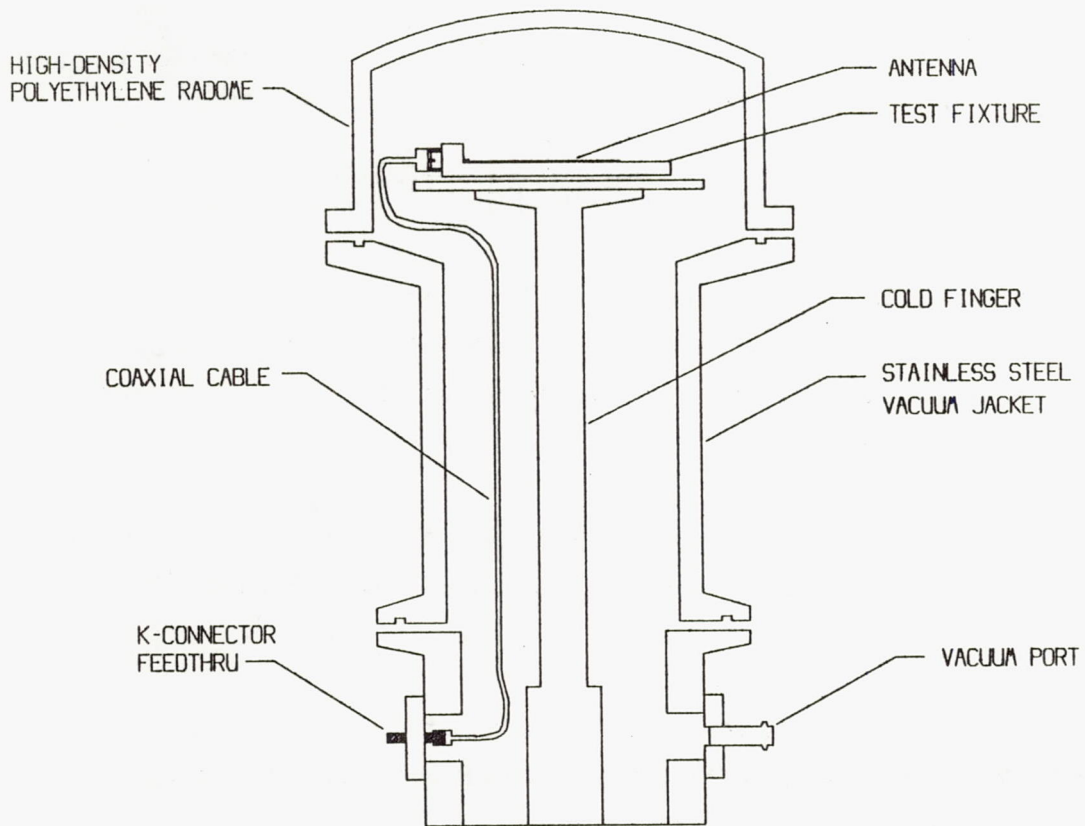

Fig. 1. Cryogenic antenna test unit.

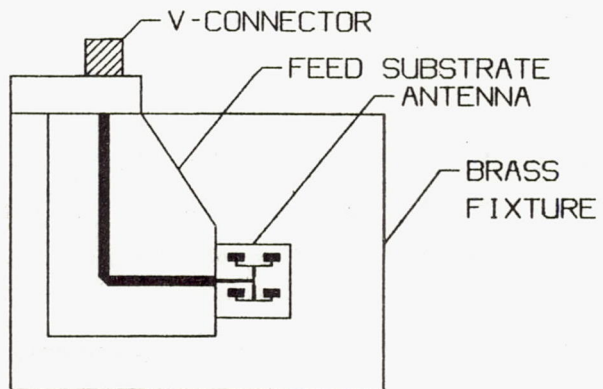

Fig. 2. Four element microstrip antenna in brass test fixture.

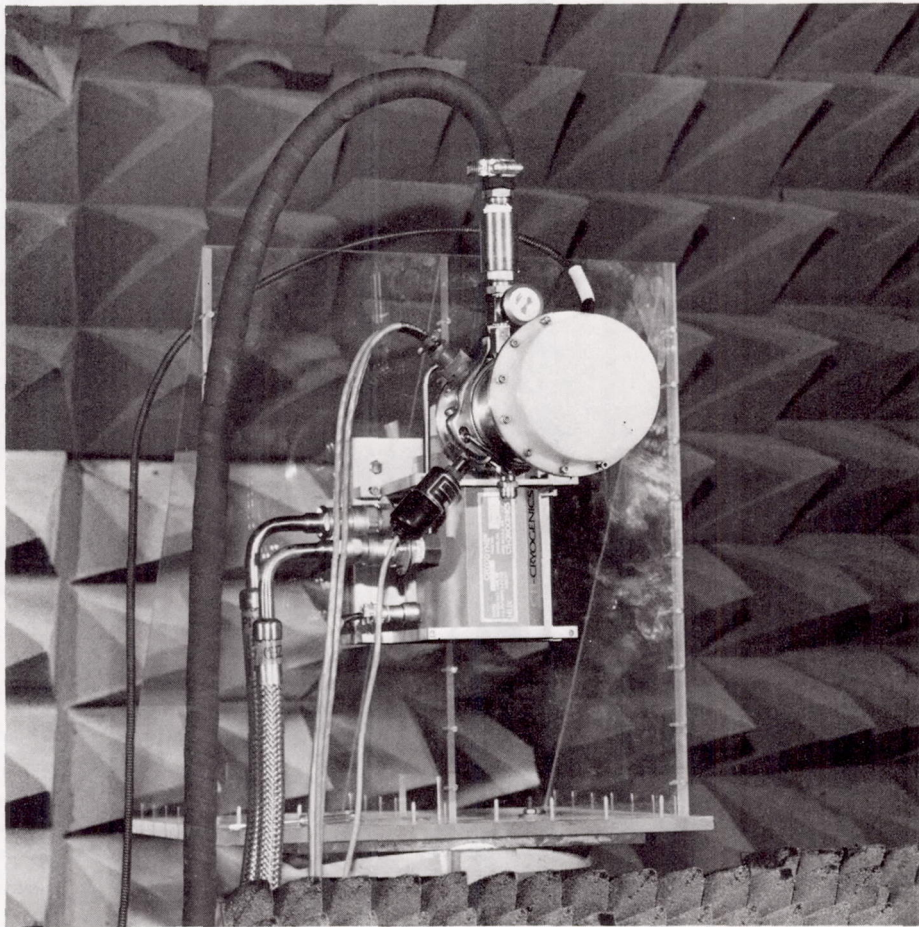

Fig. 3. Cryogenic unit mounted on rotating pedestal of the far field antenna range.

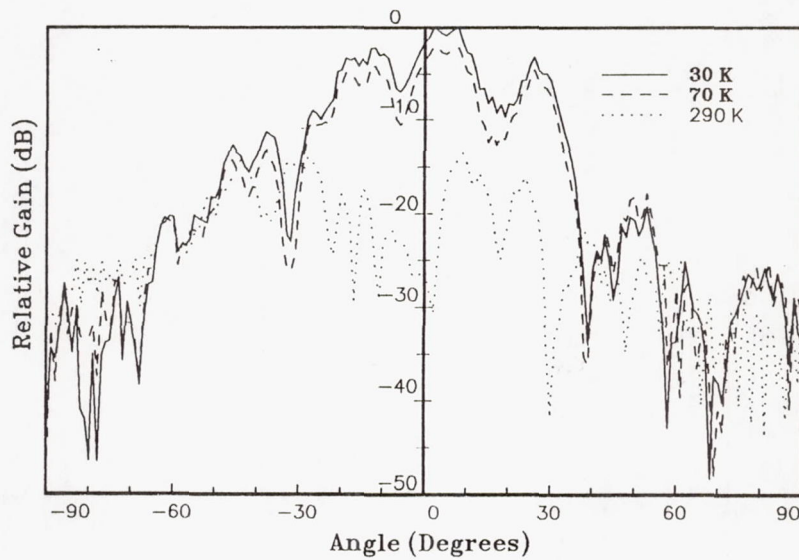

Fig. 4. H-plane patterns of 4-element HTS array on MgO substrate taken at 290, 70, and 30 Kelvin.

REPORT DOCUMENTATION PAGE

Form Approved
OMB No. 0704-0188

Public reporting burden for this collection of information is estimated to average 1 hour per response, including the time for reviewing instructions, searching existing data sources, gathering and maintaining the data needed, and completing and reviewing the collection of information. Send comments regarding this burden estimate or any other aspect of this collection of information, including suggestions for reducing this burden, to Washington Headquarters Services, Directorate for Information Operations and Reports, 1215 Jefferson Davis Highway, Suite 1204, Arlington, VA 22202-4302, and to the Office of Management and Budget, Paperwork Reduction Project (0704-0188), Washington, DC 20503.

| | | | |
|--|--|---|--|
| 1. AGENCY USE ONLY (<i>Leave blank</i>) | 2. REPORT DATE | 3. REPORT TYPE AND DATES COVERED Technical Memorandum | |
| 4. TITLE AND SUBTITLE Measurement Techniques for Cryogenic Ka-Band Microstrip Antennas | | 5. FUNDING NUMBERS WU 506-59-4C | |
| 6. AUTHOR(S) M.A. Richard, K.B. Bhasin, C. Gilbert, S. Metzler, and P.C. Claspy | | 8. PERFORMING ORGANIZATION REPORT NUMBER E-6479 | |
| 7. PERFORMING ORGANIZATION NAME(S) AND ADDRESS(ES) National Aeronautics and Space Administration Lewis Research Center Cleveland, Ohio 44135-3191 | | 10. SPONSORING/MONITORING AGENCY REPORT NUMBER NASA TM-105183 | |
| 9. SPONSORING/MONITORING AGENCY NAMES(S) AND ADDRESS(ES) National Aeronautics and Space Administration Washington, D.C. 20546-0001 | | 11. SUPPLEMENTARY NOTES Prepared for the 13th Annual Meeting and Symposium of the Antenna Measurement Techniques Association sponsored by the National Institute of Standards and Technology, Boulder, Colorado, October 7-11, 1991. M.A. Richard, Case Western Reserve University, Department of Electrical Engineering, Cleveland, Ohio 44106 (work partially funded by the | |
| 12a. DISTRIBUTION/AVAILABILITY STATEMENT Unclassified - Unlimited Subject Category 33 | | 12b. DISTRIBUTION CODE | |
| 13. ABSTRACT (<i>Maximum 200 words</i>) The measurement of cryogenic antennas poses unique logistical problems since the antenna under test must be embedding in the cooling chamber. In this paper, a method of measuring the performance of cryogenic microstrip antennas using a closed cycle gas-cooled refrigerator in a far field range is described. Antenna patterns showing the performance of gold and super-conducting Ka-band microstrip antennas at various temperatures are presented. | | | |
| 14. SUBJECT TERMS Microwave antenna; High temperature superconductivity; Low temperature tests | | 15. NUMBER OF PAGES 10 | |
| 17. SECURITY CLASSIFICATION OF REPORT Unclassified | | 16. PRICE CODE A03 | |
| 18. SECURITY CLASSIFICATION OF THIS PAGE Unclassified | 19. SECURITY CLASSIFICATION OF ABSTRACT Unclassified | 20. LIMITATION OF ABSTRACT | |

11. Supplementary Notes (continued)

NASA Space Grant College Fellowship's Program, Grant Number NGT-40016, and a NASA Space Grant Fellowship from the Ohio Aerospace Institute). K.B. Bhasin, NASA Lewis Research Center. C. Gilbert and S. Metzler, Ball Communications Systems Division, Broomfield, Colorado 80020. P.C. Claspy, Case Western Reserve University, Department of Electrical Engineering. Responsible person, K.B. Bhasin, (216) 433-3676.