

NASA Technical Memorandum 105139

A Qualitative View of Cryogenic Fluid Injection Into High Speed Flows

R.C. Hendricks, J. Schlumberger, and M. Proctor
Lewis Research Center
Cleveland, Ohio

Prepared for the
XVIIIth International Congress of Refrigeration
Montreal, Canada, August 10-17, 1991

NASA

A QUALITATIVE VIEW OF CRYOGENIC FLUID INJECTION

INTO HIGH SPEED FLOWS

R.C. Hendricks, J. Schlumberger, M. Proctor
National Aeronautics and Space Administration
Lewis Research Center
Cleveland, Ohio 44135

ABSTRACT

The injection of supercritical pressure, subcritical-temperature fluids air and nitrogen, into a two-dimensional, ambient, static-temperature and static-pressure supersonic tunnel and free jet supersonic nitrogen flow field was observed.

Observed patterns with fluid air were the same as those observed for fluid nitrogen injected into the tunnel at 90° to the supersonic flow. The nominal injection pressure was of 6.9 MPa and tunnel Mach number was 2.7.

When injected directly into an opposing tunnel exhaust flow the observed patterns with fluid air were similar to those observed for fluid nitrogen but appeared more diffusive. Cryogenic injection creates a high density region within the bow shock wake but the standoff distance remains unchanged from the gaseous value. However as the temperature reaches a critical value T^*,inj the shock faded and advanced into the supersonic stream. For both fluids nitrogen and air the phenomena was completely reversible.

INTRODUCTION AND OBJECTIVES

The fracturing of a supercritical-pressure water stream discharged to ambient conditions has been studied by Field and Lesser /1/. The shock structure is evidenced in his photographs and stream breakup is cataclysmic. Droplets are rapidly disbursed. The fracturing of sub- and supercritical-pressure, radial inward flows has been studied by Hendricks, et al. /2/. Motion pictures of the flow between parallel disks spaced 0.076 mm apart show rapid stream breakup immediately downstream of the exit plane. The flow appears finely disbursed with the potential of fluid fracture occurring within the passage.

The penetration of a supersonic flow field by cryogen injection was found to be strongly dependent on the flow Mach number, the cryogen injection pressure (P_i/P_c), and injector geometry /3/. The normalized penetration distances were found to be less than those of Reichenbach and Horn /4/, but followed similar trends with injection pressures.

From these experiments /1/, /4/ it is clear that supercritical-pressure jets fracture almost immediately after discharge and that fluid streams can penetrate supersonic flow fields. It is also clear that when high pressure fluid nitrogen at $T_{inj} < T^*,inj = 90$ K, is injected directly into a gaseous supersonic flow the shock front becomes diffusive /5/.

Herein we describe a qualitative investigation of injecting fluid air, a mixture, into a supersonic flow similar to that described in /4/, /5/.

MATERIAL AND METHODS

The experiment is classically simple. A Mach 2.7 two-dimensional gas nitrogen tunnel is coupled with a high pressure cryogenic source (Figure 1).

The tunnel operates at 2.3 MPa in the chamber, achieving Mach 2.7 at ambient pressure. This flow field is maintained for nearly 720 mm and provides ample distance for flow observations via the 25 mm Lucite cover plates. The tunnel cross section was 16 by 25 mm at the throat and 16 by 106 mm at the constant section.

The tunnel was calibrated by using several types of probes that measured stagnation pressures in the exhaust stream as described in /3/.

Fluid air was passed through a copper coiled heat exchanger in a liquid nitrogen bath open to ambient to both reduce and maintain constant injection temperature.

For tunnel injection at 90° a flush mounted 3.2 mm I.D. copper tube was used. Temperature and pressure were measured prior to injection.

For injection into and opposing the supersonic free flow a 3.2 mm O.D. by 1.6 mm I.D. copper tube was mounted 25 mm above the nozzle exhaust plane and centered in the exhaust stream. The pressure was measured prior to injection and the temperature was measured less than 0.5 diameters from the tube tip. The thermocouple ball was soldered to the tube and the lead wires tightly wrapped around the tube out of the flow field.

A second injector (Figure 2), had a 1.6 mm I.D. injection port, arbitrary external geometry, no thermocouple, and was mounted approximately 105 mm above and centered in the nozzle exhaust stream.

A shadowgraph scheme was devised to observe the flow field and the results were recorded on videotape. The flow field noise level was intense and strongly effected some videocameras. The flow details are strictly qualitative.

RESULTS AND DISCUSSION

Data was difficult to acquire and interpret, as reported in /3 and 5/, and the injected jet "fluttered" unstably. The interface of the free stream and injected fluid was diffusive, two phase, and unstable; only data for the developed flow injection ports are discussed.

For injection 90° to the tunnel wall the nominal cryogen fluid injection pressure was set to 6.9 MPa to determine if the penetration distance for fluids air and nitrogen differed. For the case cited, and within the limits of these tests, no significant difference was found. The penetration distance was up to one-half the tunnel width and further tests eliminated.

In all instances the injected fluid forms a diffusive region rather than a sharp shock front and is rapidly swept downstream. The region resembles a separation bubble (Figure 3).

For jet injection the shock front dissipation for fluid air and nitrogen was also similar. The shadowgraph images illustrate the nature of the flows. Figures 4(a) and 5(a) show gaseous nitrogen and air injection into the supersonic flow field. The injection pressure is a nominal 6.9 MPa. The sharp interface of the bow shock is clear in both fluids.

With cryogenic injection, and the injection temperature decreasing toward T_{inj}^* (=90 K), the sharpness of the bow shock declines and the shock interface standoff distance begins to increase as the shock begins to advance into the supersonic flow stream, Figures 4(b) and 5(b).

For $T_{inj} < T_{inj}^*$ the appearance of Mach lines and the growth of the injected region continues. The standoff distance continues to increase (Figures 4(c) and 5(c)). For both fluids the shock appears dissipated but more diffusive for fluid air.

Each step of the shock dissipation can be readily retraced by increasing T_{inj}^* until $T_{inj} = T_{inj}^*$ and the bow shock will reappear for all $T_{inj} > T_{inj}^*$. Small temperature changes about T_{inj}^* provide a shock or no shock phenomena for both fluid air and nitrogen.

Even for an arbitrary geometry, Figure 2, the bow shock stands off the injector when gaseous nitrogen is injected, Figure 6(a). Decreasing T_{inj} toward T_{inj}^* the shock front weakens, Figure 6(b). For $T_{inj} < T_{inj}^*$ the shock front is dissipated, Figure 6(c).

The enriched fluid air as condensed and used herein was nominally 20 to 28 percent oxygen with an undetermined amount of water and carbon-dioxide solid. As such it was also enriched with entrapped solids. The 5 K difference between air and nitrogen saturation temperatures was expected to enhance shock advancement into the supersonic stream but interface fluttering obscured the details and remains a question to be answered through further testing.

CONCLUSION AND SIGNIFICANT FINDINGS

For a two-dimensional, gaseous nitrogen, Mach 2.7 tunnel, with cryogen air injected at 6.9 MPa through a 3.2 mm diameter tube at 90° to the flow the penetration distance approached one-half the tunnel width. The result was the same as for fluid nitrogen injection.

When injecting supercritical pressure enriched fluid air directly into and opposing the supersonic flow there was no effect on the bow shock for temperatures above the critical injection temperature (90 K). However for injection temperatures below the critical injection temperature the shock strength weakens and becomes diffusive. The observed phenomena is completely reversible.

The enriched air mixture (nominally 20 to 28 percent oxygen) also had an undetermined amount of solid water and carbon-dioxide solid entrapped. The mixture components may have caused the diffuse, unsteady nature of the interface when compared to single component fluid nitrogen.

Photographic details of the interface are lacking, so how the interface fractures and the dynamics of the interface are not resolved.

REFERENCES

1. Field, J.E., and Lesser, M.B. (1977): Proc. R. Soc. Lond. A. 357.
2. Hendricks, R.C., Simoneau, R.J., and Hsu, Y.Y. (1975): Ad. in Cryo. Engr., Vol. 20, Plenum Press.
3. Hendricks, R.C., Boldman, D.R., Neumann, H.E., Vlcek, B.L. (1990): Ad. in Cryo. Engr., Vol. 26, Plenum Press.
4. Reichenback, R.E., and Horn, K.P. (1971): AIAA Jl. V9 No. 3 (March).
5. Hendricks, R.C. (1991): CEC/ICMC Huntsville Alabama, Paper.

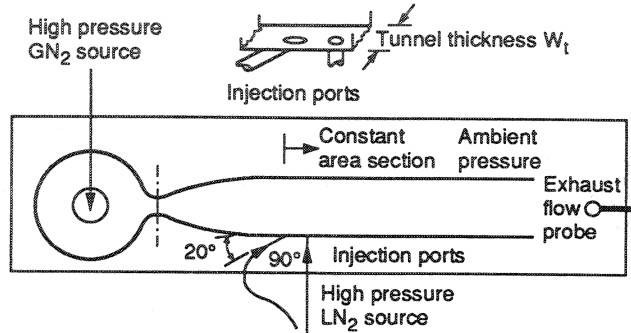

Figure 1.—Test section schematic.

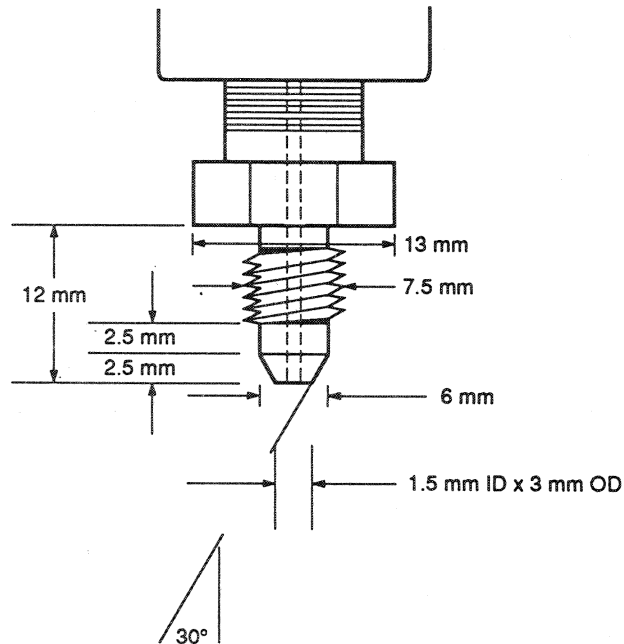

Figure 2.—Irregular shaped body (ref 1/16 - AN fitting).

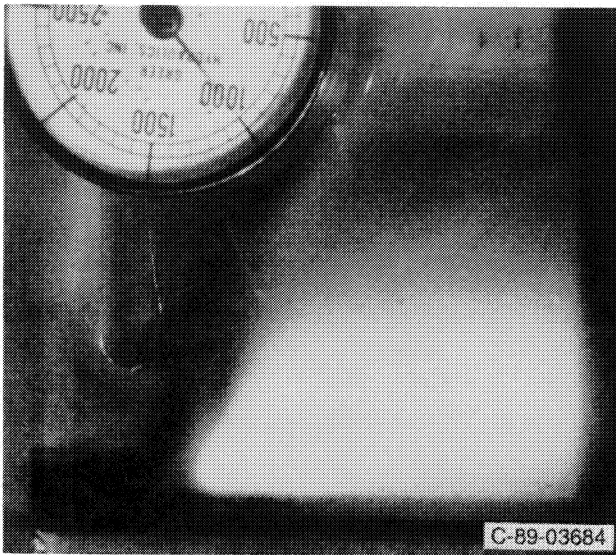
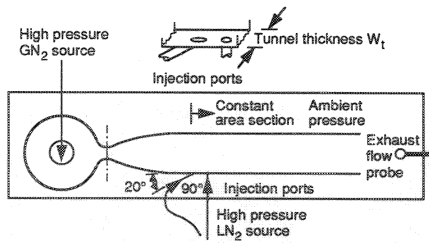
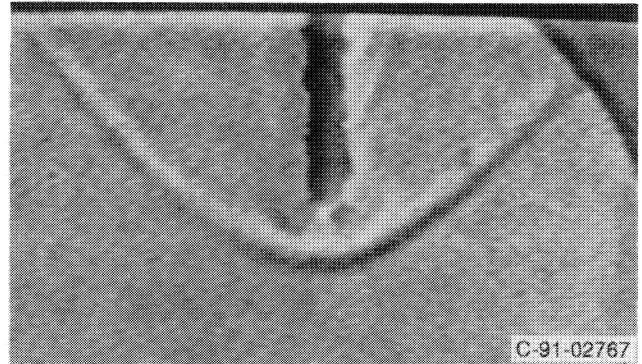
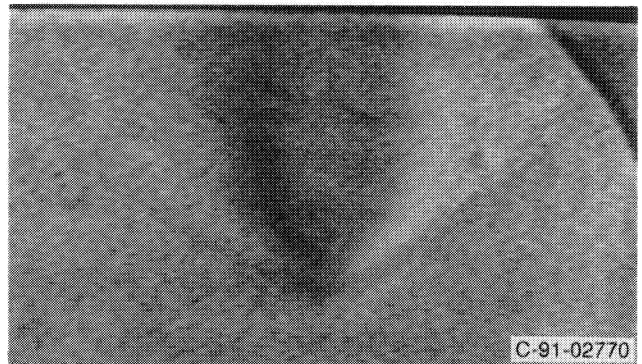

Figure 3.—Photograph of injection interfaces. Flow mach no. 2.7; injection pressure at 1000 psi, 90° injection angle.



(a) Gas nitrogen injection bow shock formation.



(b) Fluid nitrogen injection – initial shock dissipation.

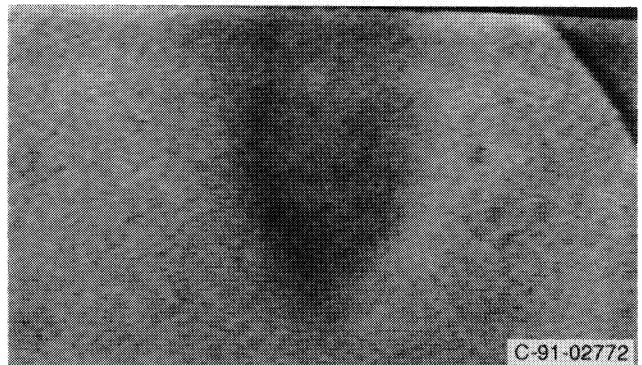

(c) Nitrogen injection $T < 100\text{ K}$ – shock dissipation.

Figure 4.—Fluid nitrogen injection into and opposing a $M = 2.7$ jet. Injection pressure = 6.9 MPa.

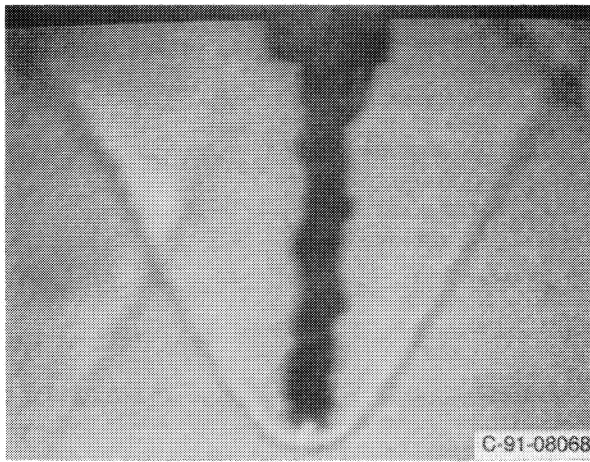

(a) Gas air injection.

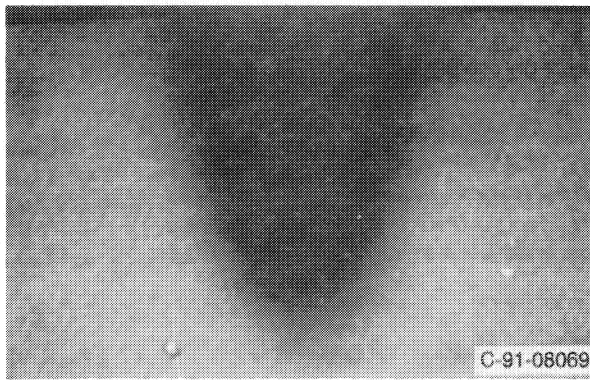

(b) Liquid air injection $T_{inj} \approx T_{inj}^*$

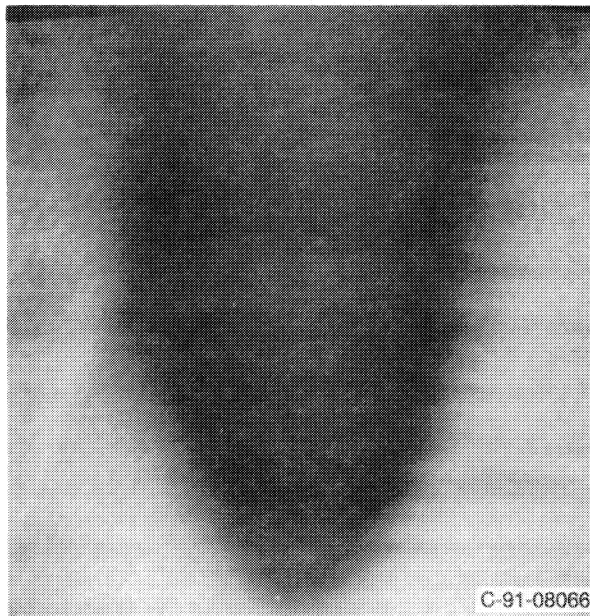

(c) Liquid air injection $T_{inj} < 90$ K.

Figure 5.—Fluid air injection into and opposing a $M = 3.0$ jet. Injection pressure = 6.9 MPa.

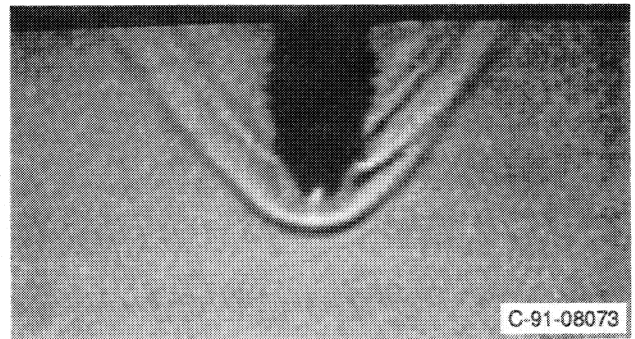

(a) Gas air injection.

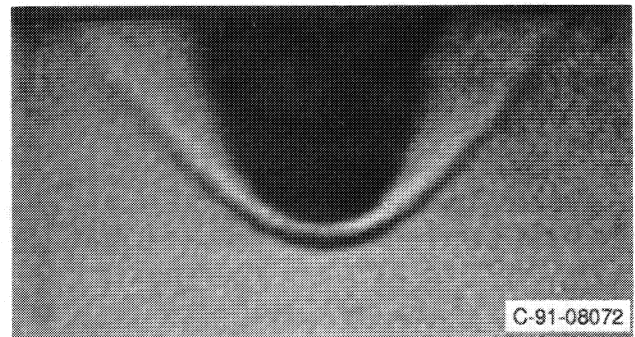

(b) Liquid air injection $T_{inj} > 100$ K.

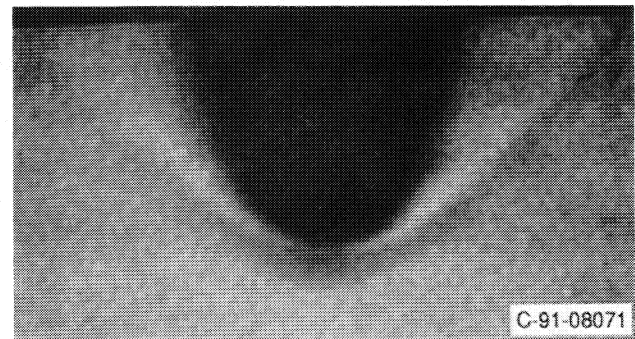

(c) Liquid air injection - weakened shock.

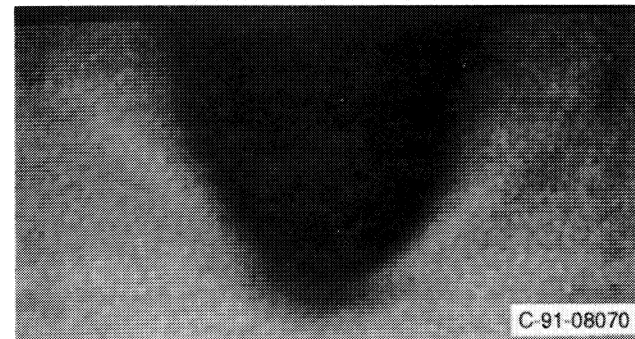

(d) Liquid air injection - dissipated shock.

Figure 6.—Fluid air injection into an opposing $M = 2.7$ gas nitrogen jet for an arbitrary geometry. Nominal injection pressure = 6.9 MPa.

REPORT DOCUMENTATION PAGE

Form Approved
OMB No. 0704-0188

Public reporting burden for this collection of information is estimated to average 1 hour per response, including the time for reviewing instructions, searching existing data sources, gathering and maintaining the data needed, and completing and reviewing the collection of information. Send comments regarding this burden estimate or any other aspect of this collection of information, including suggestions for reducing this burden, to Washington Headquarters Services, Directorate for Information Operations and Reports, 1215 Jefferson Davis Highway, Suite 1204, Arlington, VA 22202-4302, and to the Office of Management and Budget, Paperwork Reduction Project (0704-0188), Washington, DC 20503.

1. AGENCY USE ONLY (<i>Leave blank</i>)		2. REPORT DATE August 1991	3. REPORT TYPE AND DATES COVERED Technical Memorandum	
4. TITLE AND SUBTITLE A Qualitative View of Cryogenic Fluid Injection Into High Speed Flows			5. FUNDING NUMBERS WU-505-62-52	
6. AUTHOR(S) R.C. Hendricks, J. Schlumberger, and M. Proctor				
7. PERFORMING ORGANIZATION NAME(S) AND ADDRESS(ES) National Aeronautics and Space Administration Lewis Research Center Cleveland, Ohio 44135-3191			8. PERFORMING ORGANIZATION REPORT NUMBER E-6410	
9. SPONSORING/MONITORING AGENCY NAME(S) AND ADDRESS(ES) National Aeronautics and Space Administration Washington, DC 20546-0001			10. SPONSORING/MONITORING AGENCY REPORT NUMBER NASA TM-105139	
11. SUPPLEMENTARY NOTES Prepared for the XVIIIth International Congress of Refrigeration, Montreal, Canada, August 10-17, 1991. Responsible person, R.C. Hendricks, 216-433-5912.				
12a. DISTRIBUTION/AVAILABILITY STATEMENT Unclassified - Unlimited Subject Category: 34 Available electronically at http://gltrs.grc.nasa.gov This publication is available from the NASA Center for AeroSpace Information, 301-621-0390.			12b. DISTRIBUTION CODE	
13. ABSTRACT (<i>Maximum 200 words</i>) The injection of supercritical pressure, subcritical-temperature fluids, into a two-dimensional, ambient, static-temperature and static-pressure supersonic tunnel and free jet supersonic nitrogen flow field was observed. Observed patterns with fluid air were the same as those observed for fluid nitrogen injected into the tunnel at 90° to the supersonic flow. The nominal injection pressure was of 6.9 MPa and tunnel Mach number was 2.7. When injected directly into an opposing tunnel exhaust flow the observed patterns with fluid air were similar to those observed for fluid nitrogen but appeared more diffusive. Cryogenic injection creates a high density region within the bow shock wake but the standoff distance remains unchanged from the gaseous value. However as the temperature reaches a critical value T_{inj}^* , the shock faded and advanced into the supersonic stream. For both fluids nitrogen and air the phenomena was completely reversible.				
14. SUBJECT TERMS Shocks; Cryogenics; Injection			15. NUMBER OF PAGES 8	
			16. PRICE CODE A02	
17. SECURITY CLASSIFICATION OF REPORT Unclassified	18. SECURITY CLASSIFICATION OF THIS PAGE Unclassified	19. SECURITY CLASSIFICATION OF ABSTRACT Unclassified	20. LIMITATION OF ABSTRACT	